

FCC Test Report

Product Name : Venation E2 IoT Gateway
Trade Name : ARDOMUS
Model No. : VE2A01
FCC ID : 2AUSBVEHA1

Applicant : Ardomus Networks Corporation
Address : 1F., No. 295-2, Shixing Rd., Zhubei City,
Hsinchu County 30286, Taiwan

Date of Receipt : Jan. 13, 2020
Issued Date : Jun. 16, 2021
Report No. : 2010134R-RFUSP26V00
Report Version : V1.0



The test results relate only to the samples tested.

The test report shall not be reproduced except in full without the written approval of DEKRA Testing and Certification Co., Ltd..

Test Report Certification

Issued Date : Jun. 16, 2021

Report No. : 2010134R-RFUSP26V00



Product Name : Venation E2 IoT Gateway
Applicant : Ardopus Networks Corporation
Address : 1F., No. 295-2, Shixing Rd., Zhubei City, Hsinchu County 30286, Taiwan
Manufacturer : MitraStar Technology Corporation
Address : No. 6, Innovation Rd II, Science-Based Industrial, Hsin-Chu, Taiwan
Model No. : VE2A01
FCC ID : 2AUSBVEHA1
EUT Test Voltage : AC 100-240V, 50/60Hz
Testing Voltage : AC 120V/60Hz
Trade Name : ARDOMUS
Applicable Standard : FCC CFR Title 47 Part 15 Subpart C Section 15.247: 2019
ANSI C63.10: 2013
Laboratory Name : Hsin Chu Laboratory
Address : No.372-2, Sec. 4, Zhongxing Rd., Zhudong Township, Hsinchu County 310, Taiwan, R.O.C.
TEL: +886-3-582-8001 / FAX: +886-3-582-8958
Test Result : Complied

Documented By : 
(Lyla Yang / Engineering Adm. Specialist)

Tested By : 
(Clemens Fang / Senior Engineer)

Approved By : 
(Louis Hsu / Deputy Manager)

Revision History

Version	Description	Issued Date
V1.0	Initial issue of report	Jun. 16, 2021

TABLE OF CONTENTS

Description	Page
1. General Information	6
1.1. EUT Description.....	6
1.2. Test Mode	9
1.3. Tested System Details	10
1.4. Configuration of tested System.....	10
1.5. EUT Exercise Software.....	10
1.6. Test Facility	11
1.7. List of Test Equipment	13
1.8. Duty Cycle	17
1.9. Uncertainty.....	20
2. Aetenna Requirements	21
3. Conducted Emission.....	22
3.1. Test Setup.....	22
3.2. Limits	22
3.3. Test Procedure.....	23
3.4. Test Specification	23
3.5. Test Result.....	24
4. Maximum conducted output power.....	32
4.1. Test Setup.....	32
4.2. Test procedures	32
4.3. Limits	32
4.4. Test Specification	32
4.5. Test Result.....	33
5. Radiated Emission.....	45
5.1. Test Setup.....	45
5.2. Limits	46
5.3. Test Procedure.....	47
5.4. Test Specification	47
5.5. Test Result.....	48
6. RF antenna conducted test.....	80
6.1. Test Setup.....	80
6.2. Limits	80
6.3. Test Procedure.....	80
6.4. Test Specification	80
6.5. Test Result.....	81
7. Radiated Emission Band Edge	113

7.1. Test Setup.....	113
7.2. Limits	113
7.3. Test Procedure.....	113
7.4. Test Specification	113
7.5. Test Result.....	114
8. DTS Bandwidth.....	170
8.1. Test Setup.....	170
8.2. Test Procedures.....	170
8.3. Limits	170
8.4. Test Specification	170
8.5. Test Result.....	171
9. Occupied Bandwidth.....	187
9.1. Test Setup.....	187
9.2. Test Procedures.....	187
9.3. Limits	187
9.4. Test Specification	187
9.5. Test Result.....	188
10. Power Density.....	204
10.1. Test Setup.....	204
10.2. Limits	204
10.3. Test Procedures.....	204
10.4. Test Specification	204
10.5. Uncertainty.....	204
10.6. Test Result.....	205
Attachment.....	213
Test Setup Photograph	213

1. General Information

1.1. EUT Description

Product Name	Venation E2 IoT Gateway	
Trade Name	ARDOMUS	
Model No.	VE2A01	
Frequency Range/ Channel Number	Zigbee	2405~2480MHz / 16 Channels
	IEEE 802.11b/g	2412~2462MHz / 11 Channels
	IEEE 802.11n (20MHz)	
	IEEE 802.11n (40MHz)	2422~2452MHz / 7 Channels
Type of Modulation	Zigbee	OQPSK
	IEEE 802.11b	Direct Sequence Spread Spectrum
	IEEE 802.11g/n	Orthogonal Frequency Division Multiplexing
Data Speed	Zigbee	250kbps
	IEEE 802.11b	1, 2, 5.5, 11Mbps
	IEEE 802.11g	6, 9, 12, 18, 24, 36, 48, 54Mbps
	IEEE 802.11n	Support a subset of the combination of GI, MCS 0~MCS 15 and bandwidth defined in 802.11n

Antenna Information				
No.	Manufacturer	Model No.	Antenna Type	Antenna Gain
Wi-Fi (ANT0)	HongBo	290-10536	PCB Antenna	3.58 dBi
Wi-Fi (ANT1)	HongBo	290-10537	PCB Antenna	3.91 dBi
Zigbee	HongBo	290-10539	PCB Antenna	3.14 dBi

Note: WiFi Directional Gain: 6.76 dBi

Accessories Information	
Power Adapter	DVE, DSA-6PFG-05 FUS 050100 I/P: 100-240V~50/60Hz 0.2A O/P: +5V $\overline{=}$ 1A Cable Out: Non-Shielded, 1.5m

Note:

1. This device is a Venation E2 IoT Gateway including 2.4GHz b/g/n and 2.4GHz Zigbee transmitting and receiving functions. This report only show WiFi 2.4GHz test data.
2. These test results on a sample of the device are for the purpose of demonstrating Compliance with Part 15 Subpart C Paragraph 15.247.
3. Regards to the frequency band operation; the lowest, middle and highest frequency of channel were selected to perform the test, and then shown on this report.
4. The EUT description is from the customer declaration.

IEEE 802.11n

MCS Index	Modulation	R	N _{BPSCS}	N _{CBPS}		N _{DBPS}		Data Rate(Mb/s)			
				20MHz	40MHz	20MHz	40MHz	800ns GI		400ns GI	
								20MHz	40MHz	20MHz	40MHz
0	BPSK	1/2	1	52	108	26	54	6.5	13.5	7.2	15.0
1	QPSK	1/2	2	104	216	52	108	13.0	27.0	14.4	30.0
2	QPSK	3/4	2	104	216	78	162	19.5	40.5	21.7	45.0
3	16-QAM	1/2	4	208	432	104	216	26.0	54.0	28.9	60.0
4	16-QAM	3/4	4	208	432	156	324	39.0	81.0	43.3	90.0
5	64-QAM	2/3	6	312	648	208	432	52.0	108.0	57.8	120.0
6	64-QAM	3/4	6	312	648	234	486	58.5	121.5	65.0	135.0
7	64-QAM	5/6	6	312	648	260	540	65.0	135.0	72.2	150.0

Note 1: Support of 400ns GI is optional on transmit and receive.

Table 1 – MCS parameters for TX Antenna number = 1

MCS Index	Modulation	R	N _{BPSCS}	N _{CBPS}		N _{DBPS}		Data Rate(Mb/s)			
				20MHz	40MHz	20MHz	40MHz	800ns GI		400ns GI	
								20MHz	40MHz	20MHz	40MHz
8	BPSK	1/2	1	104	216	52	108	13.0	27.0	14.4	30.0
9	QPSK	1/2	2	208	432	104	216	26.0	54.0	28.9	60.0
10	QPSK	3/4	2	208	432	156	324	39.0	81.0	43.3	90.0
11	16-QAM	1/2	4	416	864	208	432	52.0	108.0	57.8	120.0
12	16-QAM	3/4	4	416	864	312	648	78.0	162.0	86.7	180.0
13	64-QAM	2/3	6	624	1296	416	864	104.0	216.0	115.6	240.0
14	64-QAM	3/4	6	624	1296	468	972	117.0	243.0	130.0	270.0
15	64-QAM	5/6	6	624	1296	520	1080	130.0	270.0	144.4	300.0

Note 1: Support of 400ns GI is optional on transmit and receive.

Table 2 – MCS parameters for TX Antenna number = 2

Symbol	Explanation
R	Code rate
N _{BPSCS}	Number of coded bits per single carrier
N _{CBPS}	Number of coded bits per symbol
N _{DBPS}	Number of data bits per symbol
GI	guard interval

Modulation	Channel	Power Index (Ant.0)	Power Index (Ant.1)
802.11b	1(2412MHz)	26	25
	6(2437MHz)	25	24
	11(2462MHz)	24	22
802.11g	1(2412MHz)	44	43
	6(2437MHz)	43	42
	11(2462MHz)	42	41
802.11n (20M)	1(2412MHz)	42	41
	6(2437MHz)	42	41
	11(2462MHz)	43	42
802.11n (40M)	3(2422MHz)	39	38
	6(2437MHz)	44	43
	9(2452MHz)	45	44

IEEE 802.11b/g, IEEE 802.11n (20MHz)

Working Frequency of Each Channel							
Channel	Frequency	Channel	Frequency	Channel	Frequency	Channel	Frequency
001	2412 MHz	002	2417 MHz	003	2422 MHz	004	2427 MHz
005	2432 MHz	006	2437 MHz	007	2442 MHz	008	2447 MHz
009	2452 MHz	010	2457 MHz	011	2462 MHz	-	-

IEEE 802.11n (40MHz)

Working Frequency of Each Channel							
Channel	Frequency	Channel	Frequency	Channel	Frequency	Channel	Frequency
003	2422 MHz	004	2427 MHz	005	2432 MHz	006	2437 MHz
007	2442 MHz	008	2447 MHz	009	2452 MHz	-	-

1.2. Test Mode

DEKRA has verified the construction and function in typical operation. The preliminary tests were performed in different data rate, and to find the worst condition, which was shown in this test report. The following table is the final test mode.

Test Mode	Mode 1: Transmit _CDD
-----------	-----------------------

Test Items	Modulation	Channel	Antenna	Result
Conducted Emission	11b	6	0+1	Complies
	11g	6	0+1	Complies
	11n(20MHz)	6	0+1	Complies
	11n(40MHz)	6	0+1	Complies
Maximum conducted output power	11b	1/6/10/11	0+1	Complies
	11g	1/6/10/11	0+1	Complies
	11n(20MHz)	1/6/11	0+1	Complies
	11n(40MHz)	3/6/9	0+1	Complies
Radiated Emission	11b	1/6/11	0+1	Complies
	11g	1/6/11	0+1	Complies
	11n(20MHz)	1/6/11	0+1	Complies
	11n(40MHz)	3/6/9	0+1	Complies
RF antenna conducted test	11b	1/6/11	0+1	Complies
	11g	1/6/11	0+1	Complies
	11n(20MHz)	1/6/11	0+1	Complies
	11n(40MHz)	3/6/9	0+1	Complies
Radiated Emission Band Edge	11b	1/6/10/11	0+1	Complies
	11g	1/6/10/11	0+1	Complies
	11n(20MHz)	1/6/11	0+1	Complies
	11n(40MHz)	3/6/9	0+1	Complies
DTS Bandwidth	11b	1/6/11	0+1	Complies
	11g	1/6/11	0+1	Complies
	11n(20MHz)	1/6/11	0+1	Complies
	11n(40MHz)	3/6/9	0+1	Complies
Occupied Bandwidth	11b	1/6/11	0+1	Complies
	11g	1/6/11	0+1	Complies
	11n(20MHz)	1/6/11	0+1	Complies
	11n(40MHz)	3/6/9	0+1	Complies
Power Density	11b	1/6/11	0+1	Complies
	11g	1/6/11	0+1	Complies
	11n(20MHz)	1/6/11	0+1	Complies
	11n(40MHz)	3/6/9	0+1	Complies

Determining compliance shall be based on the results of the compliance measurement, not taking into account measurement instrumentation uncertainty.

1.3. Tested System Details

The types for all equipments, plus descriptions of all cables used in the tested system (including inserted cards) are:

Product	Manufacturer	Model No.	Serial No.	FCC ID	Power Cord
1 Notebook PC	Dell	E6320	8611271467	DoC	Non-Shielded, 1.8m, one ferrite core bonded

1.4. Configuration of tested System

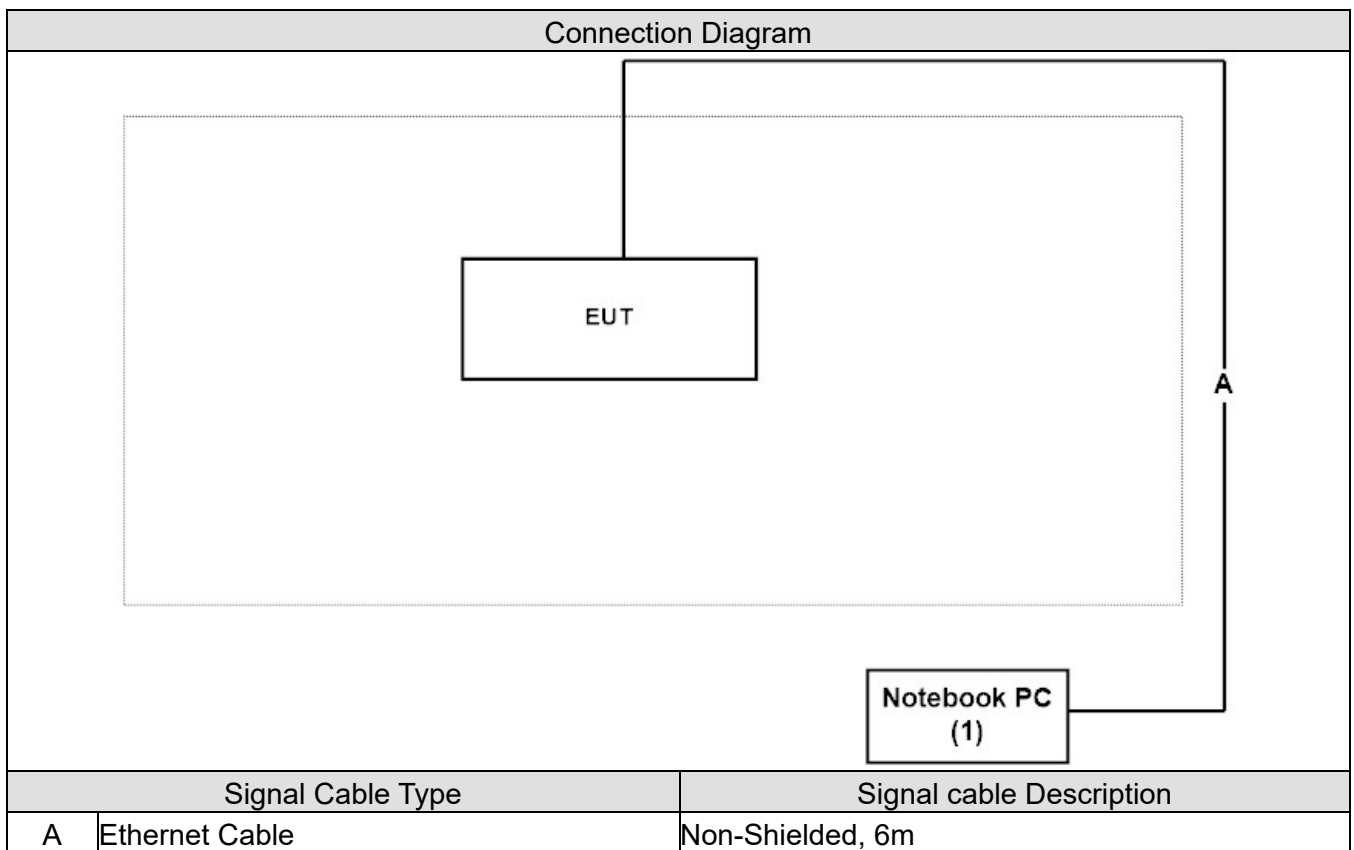

1.5. EUT Exercise Software

1	Set the EUT according to the picture above
2	EUT power is on
3	Start on software MP Tool and set relevant parameters
4	Confirm that the signal sent is correct

1.6. Test Facility

Ambient conditions in the laboratory:

Items	Test Item	Required	Test Site
Temperature (°C)	FCC PART 15 C 15.207	15 - 35	2
Humidity (%RH)	Conducted Emission	25 - 75	
Temperature (°C)	FCC PART 15 C 15.247	15 - 35	1
Humidity (%RH)	Maximum conducted output power	25 - 75	
Temperature (°C)	FCC PART 15 C 15.247	15 - 35	1
Humidity (%RH)	Radiated Emission	25 - 75	
Temperature (°C)	FCC PART 15 C 15.247	15 - 35	1
Humidity (%RH)	RF antenna conducted test	25 - 75	
Temperature (°C)	FCC PART 15 C 15.247	15 - 35	1
Humidity (%RH)	Radiated Emission Band Edge	25 - 75	
Temperature (°C)	FCC PART 15 C 15.247	15 - 35	1
Humidity (%RH)	Occupied Bandwidth & DTS Bandwidth	25 - 75	
Temperature (°C)	FCC PART 15 C 15.247	15 - 35	1
Humidity (%RH)	Power Density	25 - 75	

Note: Test Site information refers to Laboratory Information.

Laboratory Information

USA : **FCC Registration Number: TW3024**
Canada : **IC Registration Number: 22397-1 / 22397-2 / 22397-3**

The address and introduction of DEKRA Testing and Certification Co., Ltd. laboratories can be founded in our Web site : <http://www.dekra.com.tw>

If you have any comments, Please don't hesitate to contact us. Our test sites as below:

Test Laboratory	DEKRA Testing and Certification Co., Ltd.
Address	1. No.372, Sec. 4, Zhongxing Rd., Zhudong Township, Hsinchu County 31061, Taiwan, R.O.C. 2. No.372-2, Sec. 4, Zhongxing Rd., Zhudong Township, Hsinchu County 31061, Taiwan, R.O.C.
Phone number	1. +886-3-582-8001 2. +886-3-582-8001
Fax number	1. +886-3-582-8958 2. +886-3-582-8958
E mail address	info.tw@dekra.com
Website	http://www.dekra.com.tw

1.7. List of Test Equipment

Conducted Emission / SR2-H

Instrument	Manufacturer	Model No.	Serial No.	Cal. Date	Next Cal. Date
Artificial Mains Network	R&S	ENV4200	848411/010	2020/01/08	2021/01/07
Test Receiver	R&S	ESCS 30	836858/022	2020/02/25	2021/02/24
LISN	R&S	ENV216	100092	2019/07/09	2020/07/08

Maximum conducted output power / SR12-H

Instrument	Manufacturer	Model No.	Serial No.	Cal. Date	Next Cal. Date
High Speed Peak Power Meter Dual Input	Anritsu	ML2496A	1602004	2019/12/02	2020/12/01
Pulse Power Sensor	Anritsu	MA2411B	1531043	2019/12/02	2020/12/01
Pulse Power Sensor	Anritsu	MA2411B	1531044	2019/12/02	2020/12/01
Power Meter	Keysight	8990B	MY51000248	2019/05/21	2020/05/20
Power Sensor	Keysight	N1923A	MY57240005	2019/05/21	2020/05/20

Radiated Emission / CB4H

Instrument	Manufacturer	Model No.	Serial No.	Cal. Date	Next Cal. Date
Signal Analyzer	R&S	FSVA40	101455	2019/10/21	2020/10/20
Signal & Spectrum Analyzer	R&S	FSV40	101049	2020/03/30	2021/03/29
EXA Signal Analyzer	Keysight	N9010A	MY51440132	2020/02/21	2021/02/20
Bilog Antenna	Teseq	CBL6112D	23191	2019/06/17	2020/06/16
Horn Antenna	Schwarzbeck	BBHA 9120D	639	2019/05/28	2020/05/27
Horn Antenna	Schwarzbeck	BBHA 9170	202	2019/12/27	2020/12/26
Pre-Amplifier	DEKRA	AP-025C	12183122	2019/09/24	2020/09/23
Pre-Amplifier	EMCI	EMC11830I	980366	2019/12/03	2020/12/02
Pre-Amplifier	DEKRA	AP-400C	201801231	2019/12/03	2020/12/02
Horn Antenna	Schwarzbeck	BBHA 9120D	01656	2019/10/25	2020/10/24
Band Reject Filter	Micro-Tronics	BRM50702	G192	2020/03/09	2021/03/08
Signal Analyzer	R&S	FSV40	101435	2019/07/08	2020/07/07
Coaxial Cable(19m)	Suhner	SF102_SF104_SF106	CB4_2	2019/07/25	2020/07/24
EMI system	DEKRA	Version 1.0	CB4-H	NA	NA

RF antenna conducted test / SR12-H

Instrument	Manufacturer	Model No.	Serial No.	Cal. Date	Next Cal. Date
Spectrum Analyzer	Keysight	N9030B	MY57140404	2019/06/18	2020/06/17
Spectrum Analyzer	Keysight	N9010B	MY57110159	2020/04/15	2021/04/14
Spectrum Analyzer	Agilent	N9010A	US47140172	2019/06/28	2020/06/27
Signal & Spectrum Analyzer	R&S	FSV40	101049	2020/03/30	2021/03/29

Radiated Emission Band Edge / CB4-H

Instrument	Manufacturer	Model No.	Serial No.	Cal. Date	Next Cal. Date
Signal Analyzer	R&S	FSVA40	101455	2019/10/21	2020/10/20
Signal & Spectrum Analyzer	R&S	FSV40	101049	2020/03/30	2021/03/29
EXA Signal Analyzer	Keysight	N9010A	MY51440132	2020/02/21	2021/02/20
Bilog Antenna	Teseq	CBL6112D	23191	2019/06/17	2020/06/16
Horn Antenna	Schwarzbeck	BBHA 9120D	639	2019/05/28	2020/05/27
Horn Antenna	Schwarzbeck	BBHA 9170	202	2019/12/27	2020/12/26
Pre-Amplifier	DEKRA	AP-025C	12183122	2019/09/24	2020/09/23
Pre-Amplifier	EMCI	EMC11830I	980366	2019/12/03	2020/12/02
Pre-Amplifier	DEKRA	AP-400C	201801231	2019/12/03	2020/12/02
Horn Antenna	Schwarzbeck	BBHA 9120D	01656	2019/10/25	2020/10/24
Band Reject Filter	Micro-Tronics	BRM50702	G192	2020/03/09	2021/03/08
Signal Analyzer	R&S	FSV40	101435	2019/07/08	2020/07/07
Coaxial Cable(19m)	Suhner	SF102_SF104_SF106	CB4_2	2019/07/25	2020/07/24
EMI system	DEKRA	Version 1.0	CB4-H	NA	NA

Occupied Bandwidth / SR12-H

Instrument	Manufacturer	Model No.	Serial No.	Cal. Date	Next Cal. Date
Spectrum Analyzer	Keysight	N9030B	MY57140404	2019/06/18	2020/06/17
Spectrum Analyzer	Keysight	N9010B	MY57110159	2020/04/15	2021/04/14
Spectrum Analyzer	Agilent	N9010A	US47140172	2019/06/28	2020/06/27
Signal & Spectrum Analyzer	R&S	FSV40	101049	2020/03/30	2021/03/29

DTS Bandwidth / SR12-H

Instrument	Manufacturer	Model No.	Serial No.	Cal. Date	Next Cal. Date
Spectrum Analyzer	Keysight	N9030B	MY57140404	2019/06/18	2020/06/17
Spectrum Analyzer	Keysight	N9010B	MY57110159	2020/04/15	2021/04/14
Spectrum Analyzer	Agilent	N9010A	US47140172	2019/06/28	2020/06/27
Signal & Spectrum Analyzer	R&S	FSV40	101049	2020/03/30	2021/03/29

Power Density / SR12-H

Instrument	Manufacturer	Model No.	Serial No.	Cal. Date	Next Cal. Date
Spectrum Analyzer	Keysight	N9030B	MY57140404	2019/06/18	2020/06/17
Spectrum Analyzer	Keysight	N9010B	MY57110159	2020/04/15	2021/04/14
Spectrum Analyzer	Agilent	N9010A	US47140172	2019/06/28	2020/06/27
Signal & Spectrum Analyzer	R&S	FSV40	101049	2020/03/30	2021/03/29

Maximum conducted output power / SR12-H (for 802.11b & 802.11g Channel 10)

Instrument	Manufacturer	Model No.	Serial No.	Cal. Date	Next Cal. Date
High Speed Peak Power Meter Dual Input	Anritsu	ML2496A	1602004	2020/11/30	2021/11/29
Pulse Power Sensor	Anritsu	MA2411B	1531043	2020/11/30	2021/11/29
Pulse Power Sensor	Anritsu	MA2411B	1531044	2020/11/30	2021/11/29
Power Meter	Keysight	8990B	MY51000248	2021/05/21	2022/05/20
Power Sensor	Keysight	N1923A	MY57240005	2021/05/21	2022/05/20

Radiated Emission / CB4-H (for 802.11b & 802.11g Channel 10)

Instrument	Manufacturer	Model No.	Serial No.	Cal. Date	Next Cal. Date
Signal Analyzer	R&S	FSVA40	101455	2020/10/12	2021/10/11
Signal & Spectrum Analyzer	R&S	FSV40	101049	2021/03/31	2022/03/30
Signal Analyzer	R&S	FSVA40	101435	2020/06/24	2021/06/23
EXA Signal Analyzer	Keysight	N9010A	MY51440132	2021/01/25	2022/01/24
Bilog Antenna	Teseq	CBL6112D	23191	2021/02/26	2022/02/25
Horn Antenna	Schwarzbeck	BBHA 9120D	01640	2020/09/17	2021/09/16
Horn Antenna	Schwarzbeck	BBHA 9170	203	2021/03/11	2022/03/10
Pre-Amplifier	EMCI	EMC01820I	980364	2020/09/14	2021/09/13
Pre-Amplifier	EMCI	EMC0031835	980233	2020/12/07	2021/12/06
Pre-Amplifier	DEKRA	AP-400C	201801231	2020/11/16	2021/11/15
Band Reject Filter	Micro-Tronics	BRM50702	G192	2021/03/04	2022/03/03
Coaxial Cable(10m)	Suhner	SF102_SF104	CB4-H	2021/04/25	2022/04/24
DEKRA Testing System	DEKRA	Version 2.0	CB4-H	NA	NA

Note: All equipment upon which need to calibrated are with calibration period of 1 year.

1.8. Duty Cycle

Mode	On Time (ms)	On+Off Time (ms)	Duty Cycle (%)	Duty Factor(dB) linear voltage	1/T Minimum VBW (kHz)
b	8.406	8.601	97.73%	0.199191	0.119
g	1.394	1.482	94.06%	0.531709	0.717
HT20	1.307	1.432	91.27%	0.793349	0.765
HT40	0.648	0.781	82.97%	1.621321	1.544

802.11b

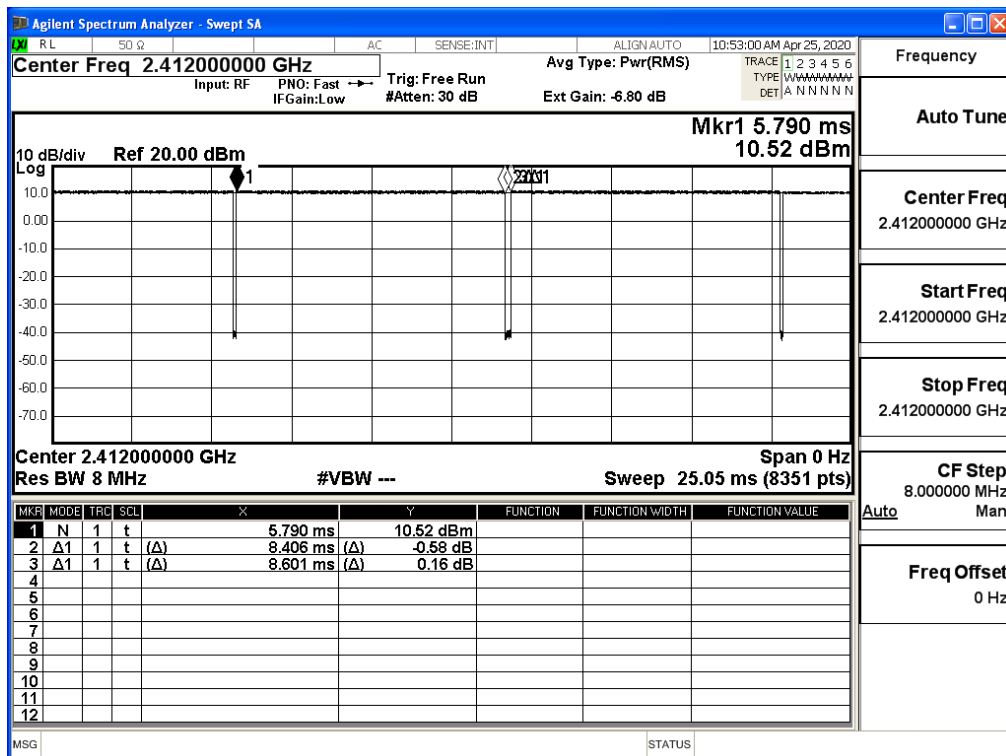

802.11g

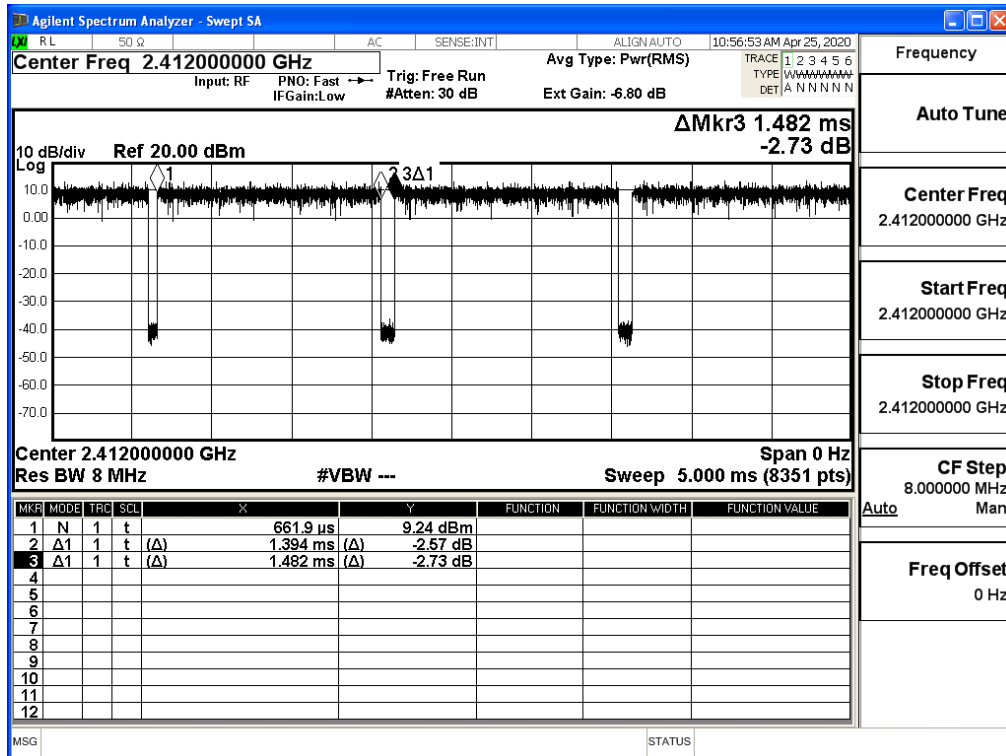

802.11n (20M)

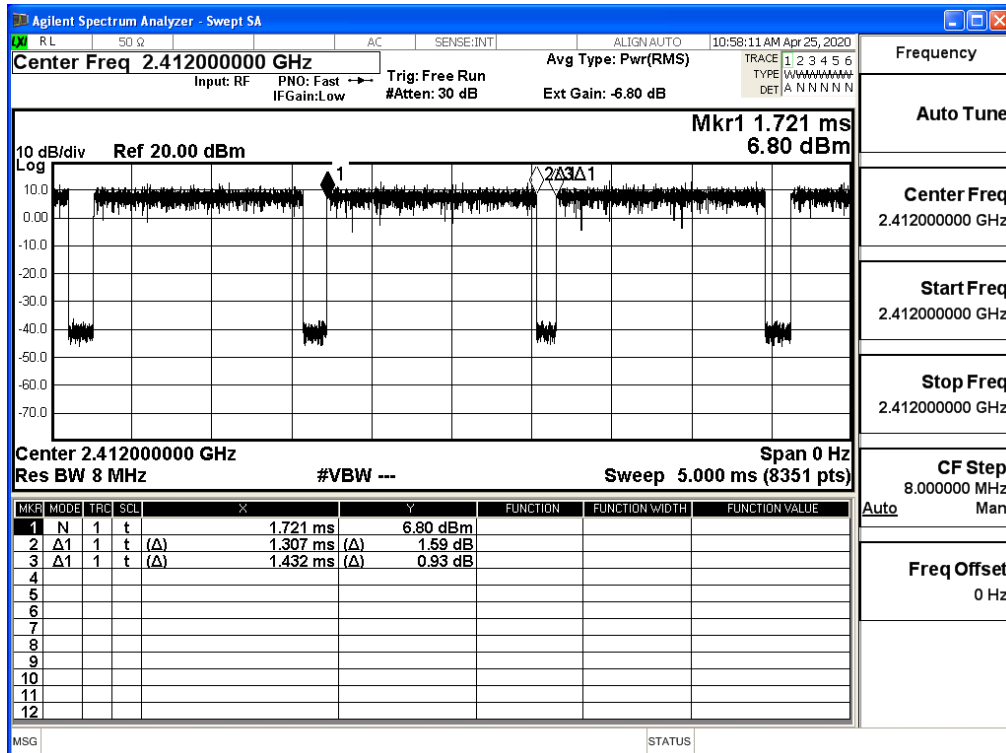

802.11n (40M)

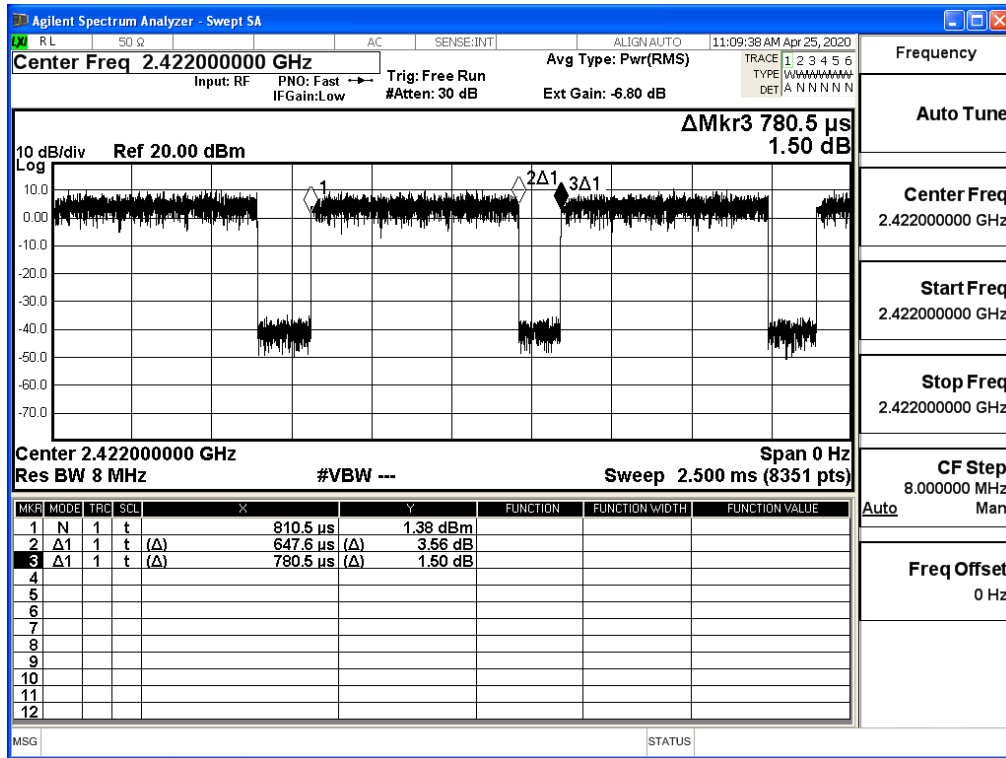

1.9. Uncertainty

Test item	Uncertainty
Conducted Emission	± 2.26 dB
Maximum conducted output power	± 1.27 dB
Radiated Emission	30MHz~1GHz as ± 3.43 dB 1GHz~26.5GHz as ± 3.65 dB
RF antenna conducted test	± 1.27 dB
Radiated Emission Band Edge	± 3.9 dB
DTS Bandwidth	± 50 Hz
Occupied Bandwidth	± 50 Hz
Power Density	± 1.27 dB

2. **Aetenna Requirements**

According to FCC 47CFR 15.203, an intentional radiator shall be designed to ensure that no antenna other than that furnished by the responsible party shall be used with the device. The use of a permanently attached antenna or of an antenna that uses a unique coupling to the intentional radiator shall be considered sufficient to comply with the provisions of this section. The manufacturer may design the unit so that a broken antenna can be replaced by the user, but the use of a standard antenna jack or electrical connector is prohibited.

3. Conducted Emission

3.1. Test Setup

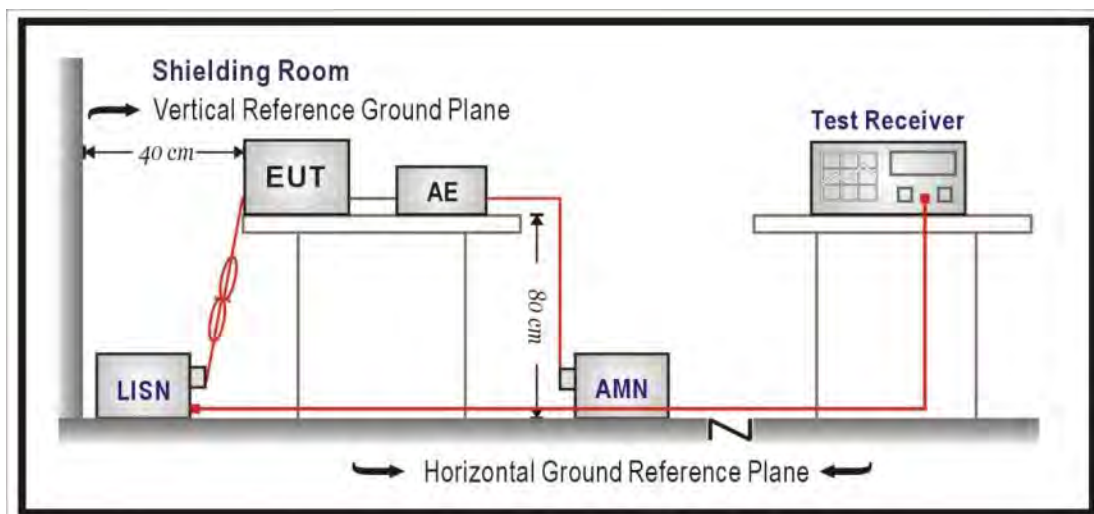

3.2. Limits

FCC Part 15 Subpart C Paragraph 15.207 Limits (dBuV)		
Frequency MHz	QP	AV
0.15 - 0.50	66 - 56	56 - 46
0.50 - 5.0	56	46
5.0 - 30	60	50

Remarks: In the above table, the tighter limit applies at the band edges.

3.3. Test Procedure

The EUT was setup according to ANSI C63.4: 2014 and tested according to DTS test procedure of KDB 558074 for compliance to FCC 47CFR 15.247 requirements.

The EUT was placed on a platform of nominal size, 1 m by 1.5 m, raised 80 cm above the conducting ground plane. The vertical conducting plane was located 40 cm to the rear of the EUT. All other surfaces of EUT were at least 80 cm from any other grounded conducting surface. The EUT and simulators are connected to the main power through a line impedance stabilization network (LISN). The LISN provides a 50 ohm /50uH coupling impedance for the measuring equipment. The peripheral devices are also connected to the main power through a LISN. (Please refer to the block diagram of the test setup and photographs.)

Each current-carrying conductor of the EUT power cord, except the ground (safety) conductor, was individually connected through a LISN to the input power source.

The excess length of the power cord between the EUT and the LISN receptacle were folded back and forth at the center of the lead to form a bundle not exceeding 40 cm in length.

Conducted emissions were investigated over the frequency range from 0.15MHz to 30MHz using a receiver bandwidth of 9 kHz.

3.4. Test Specification

According to FCC Part 15 Subpart C Paragraph 15.207: 2019

3.5. Test Result

Model No	VE2A01	Site	SR2-H
Test Voltage	AC 120V/60Hz	Test Date	2020/5/13
Test Mode	Mode 1: Transmit_CDD	Engineer	Scott
Phase	L1	Temperature (°C)	24
Test Condition	802.11b_2437MHz	Humidity (%RH)	59

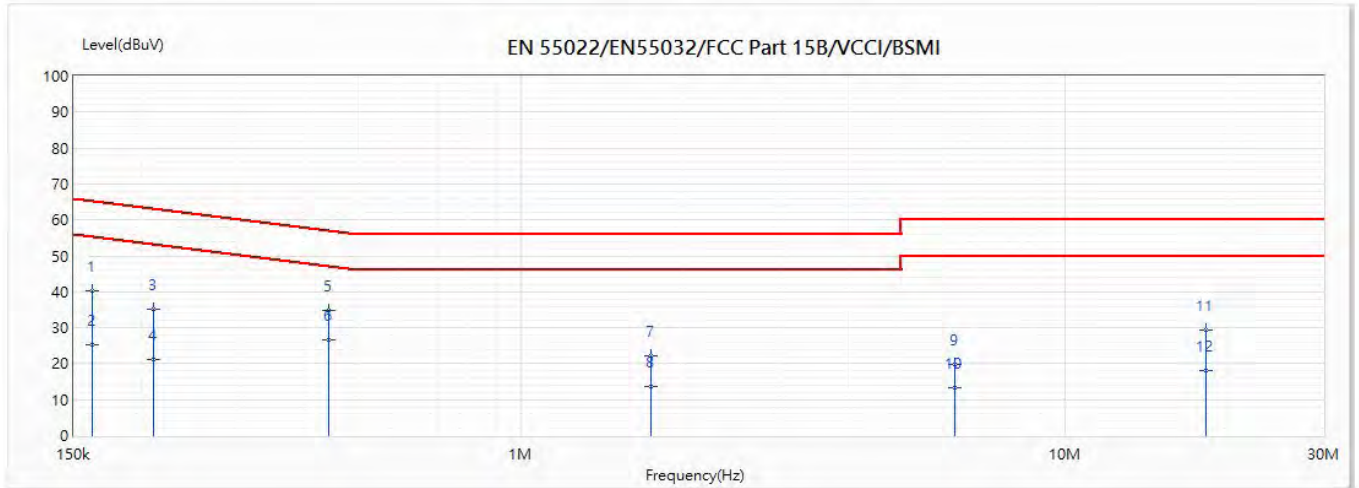

No	Frequency (MHz)	Emission Level (dBuV)	Limit (dBuV)	Margin (dB)	Reading Level (dBuV)	Correct Factor (dB)	Detector Type
1	0.162	40.32	65.66	-25.35	30.65	9.66	QP
2	0.162	25.39	55.66	-30.27	15.73	9.66	AV
3	0.21	35.09	64.29	-29.20	25.42	9.67	QP
4	0.21	21.11	54.29	-33.17	11.44	9.67	AV
5	0.442	34.96	57.64	-22.69	25.24	9.72	QP
*6	0.442	26.50	47.64	-21.14	16.78	9.72	AV
7	1.728	22.03	56.00	-33.97	12.19	9.83	QP
8	1.728	13.82	46.00	-32.18	3.98	9.83	AV
9	6.288	19.88	60.00	-40.12	9.91	9.96	QP
10	6.288	13.35	50.00	-36.65	3.38	9.96	AV
11	18.243	29.31	60.00	-30.69	19.07	10.25	QP
12	18.243	17.94	50.00	-32.06	7.70	10.25	AV

Remark:

1. "*" means this data is the worst emission level.
2. Emission Level = Reading Level + Correct Factor (Correct Factor = LISN Insertion Loss + Cable Loss).
3. Margin = Emission Level - Limit.

Model No	VE2A01	Site	SR2-H
Test Voltage	AC 120V/60Hz	Test Date	2020/5/13
Test Mode	Mode 1: Transmit_CDD	Engineer	Scott
Phase	L2	Temperature (°C)	24
Test Condition	802.11b_2437MHz	Humidity (%RH)	59

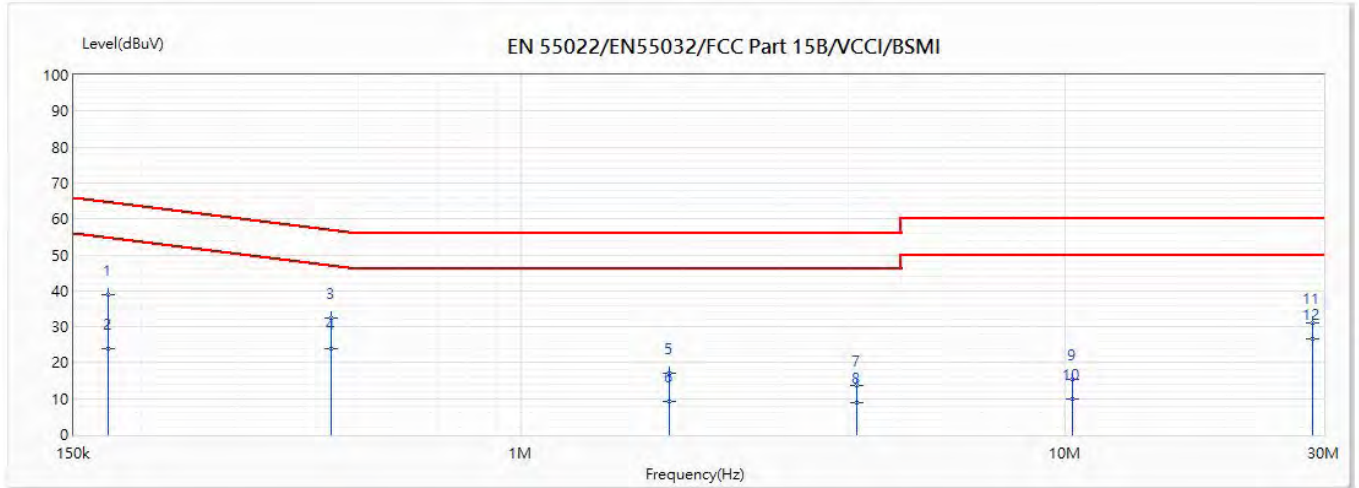

No	Frequency (MHz)	Emission Level (dBuV)	Limit (dBuV)	Margin (dB)	Reading Level (dBuV)	Correct Factor (dB)	Detector Type
1	0.173	38.93	65.33	-26.40	29.25	9.68	QP
2	0.173	23.96	55.33	-31.37	14.28	9.68	AV
3	0.445	32.27	57.56	-25.29	22.54	9.73	QP
4	0.445	23.77	47.56	-23.79	14.04	9.73	AV
5	1.875	16.99	56.00	-39.01	7.14	9.85	QP
6	1.875	9.23	46.00	-36.77	-0.62	9.85	AV
7	4.14	13.59	56.00	-42.41	3.68	9.91	QP
8	4.14	8.85	46.00	-37.15	-1.06	9.91	AV
9	10.323	15.32	60.00	-44.68	5.16	10.16	QP
10	10.323	10.03	50.00	-39.97	-0.13	10.16	AV
11	28.685	31.04	60.00	-28.96	20.42	10.62	QP
*12	28.685	26.58	50.00	-23.42	15.96	10.62	AV

Remark:

1. "*" means this data is the worst emission level.
2. Emission Level = Reading Level + Correct Factor (Correct Factor = LISN Insertion Loss + Cable Loss).
3. Margin = Emission Level - Limit.

Model No	VE2A01	Site	SR2-H
Test Voltage	AC 120V/60Hz	Test Date	2020/5/13
Test Mode	Mode 1: Transmit_CDD	Engineer	Scott
Phase	L1	Temperature (°C)	24
Test Condition	802.11g_2437MHz	Humidity (%RH)	59

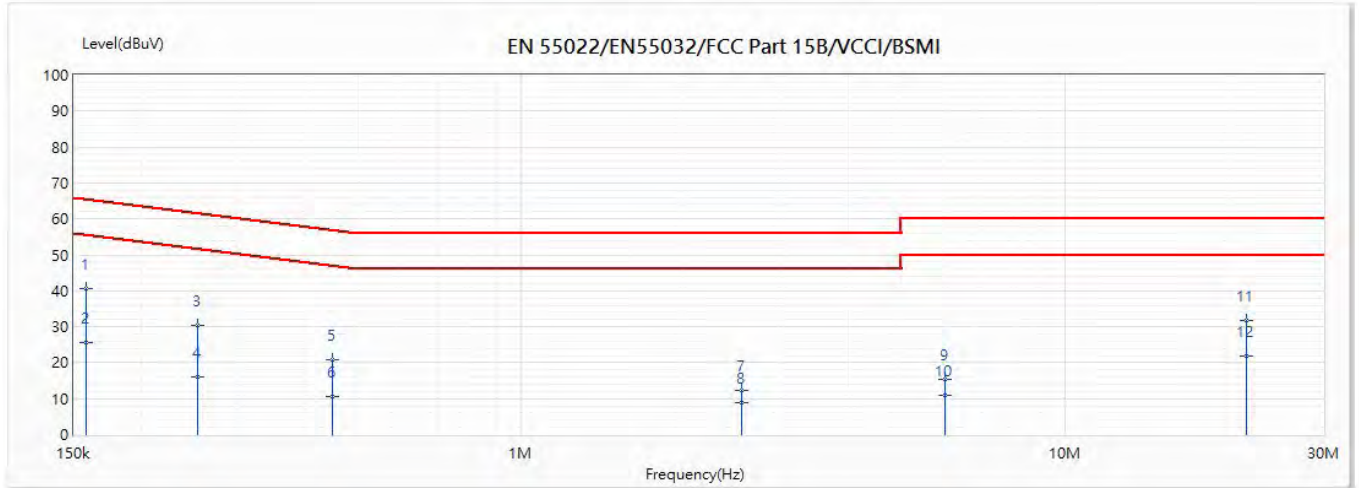

No	Frequency (MHz)	Emission Level (dBuV)	Limit (dBuV)	Margin (dB)	Reading Level (dBuV)	Correct Factor (dB)	Detector Type
*1	0.158	40.61	65.78	-25.17	30.95	9.66	QP
2	0.158	25.53	55.78	-30.24	15.87	9.66	AV
3	0.253	30.27	63.04	-32.78	20.59	9.68	QP
4	0.253	16.14	53.04	-36.90	6.46	9.68	AV
5	0.449	20.77	57.44	-36.67	11.05	9.72	QP
6	0.449	10.69	47.44	-36.75	0.97	9.72	AV
7	2.541	12.16	56.00	-43.84	2.31	9.86	QP
8	2.541	8.76	46.00	-37.24	-1.09	9.86	AV
9	6.015	15.39	60.00	-44.61	5.43	9.96	QP
10	6.015	10.94	50.00	-39.06	0.98	9.96	AV
11	21.663	31.61	60.00	-28.39	21.33	10.28	QP
12	21.663	21.93	50.00	-28.07	11.65	10.28	AV

Remark:

1. "*" means this data is the worst emission level.
2. Emission Level = Reading Level + Correct Factor (Correct Factor = LISN Insertion Loss + Cable Loss).
3. Margin = Emission Level - Limit.

Model No	VE2A01	Site	SR2-H
Test Voltage	AC 120V/60Hz	Test Date	2020/5/13
Test Mode	Mode 1: Transmit_CDD	Engineer	Scott
Phase	L2	Temperature (°C)	24
Test Condition	802.11g_2437MHz	Humidity (%RH)	59

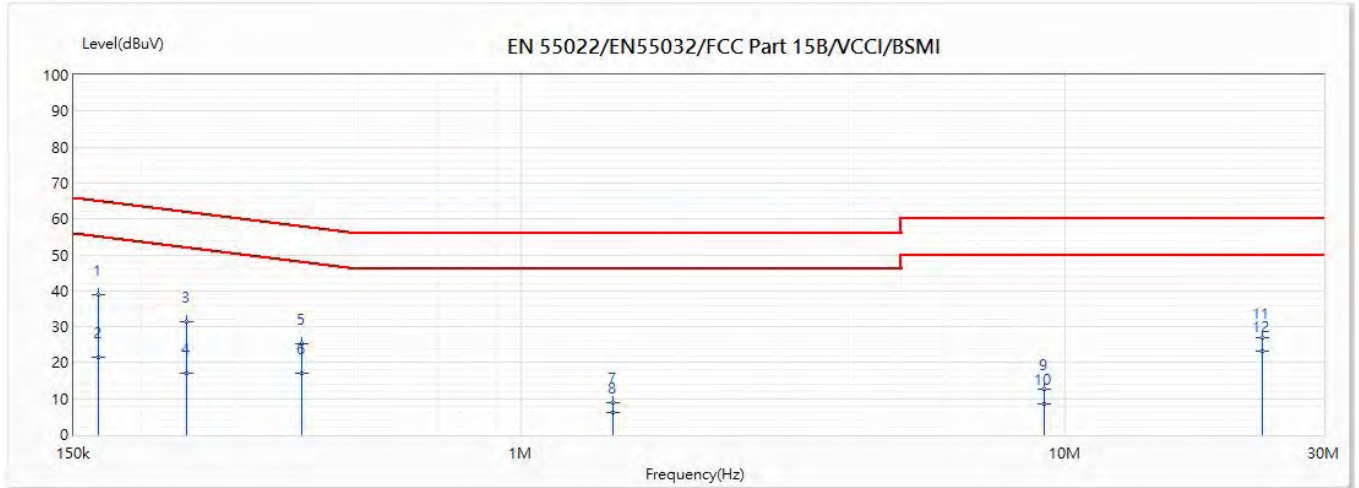

No	Frequency (MHz)	Emission Level (dBuV)	Limit (dBuV)	Margin (dB)	Reading Level (dBuV)	Correct Factor (dB)	Detector Type
*1	0.167	38.82	65.52	-26.70	29.14	9.68	QP
2	0.167	21.46	55.52	-34.06	11.78	9.68	AV
3	0.242	31.23	63.36	-32.13	21.55	9.69	QP
4	0.242	17.21	53.36	-36.15	7.52	9.69	AV
5	0.394	25.23	59.02	-33.78	15.52	9.72	QP
6	0.394	16.94	49.02	-32.08	7.22	9.72	AV
7	1.476	8.83	56.00	-47.17	-1.00	9.83	QP
8	1.476	6.05	46.00	-39.95	-3.78	9.83	AV
9	9.191	12.72	60.00	-47.28	2.60	10.12	QP
10	9.191	8.69	50.00	-41.31	-1.42	10.12	AV
11	23.129	27.05	60.00	-32.95	16.54	10.52	QP
12	23.129	23.15	50.00	-26.85	12.63	10.52	AV

Remark:

1. "*" means this data is the worst emission level.
2. Emission Level = Reading Level + Correct Factor (Correct Factor = LISN Insertion Loss + Cable Loss).
3. Margin = Emission Level - Limit.

Model No	VE2A01	Site	SR2-H
Test Voltage	AC 120V/60Hz	Test Date	2020/5/13
Test Mode	Mode 1: Transmit_CDD	Engineer	Scott
Phase	L1	Temperature (°C)	24
Test Condition	802.11n(20M)_2437MHz	Humidity (%RH)	59

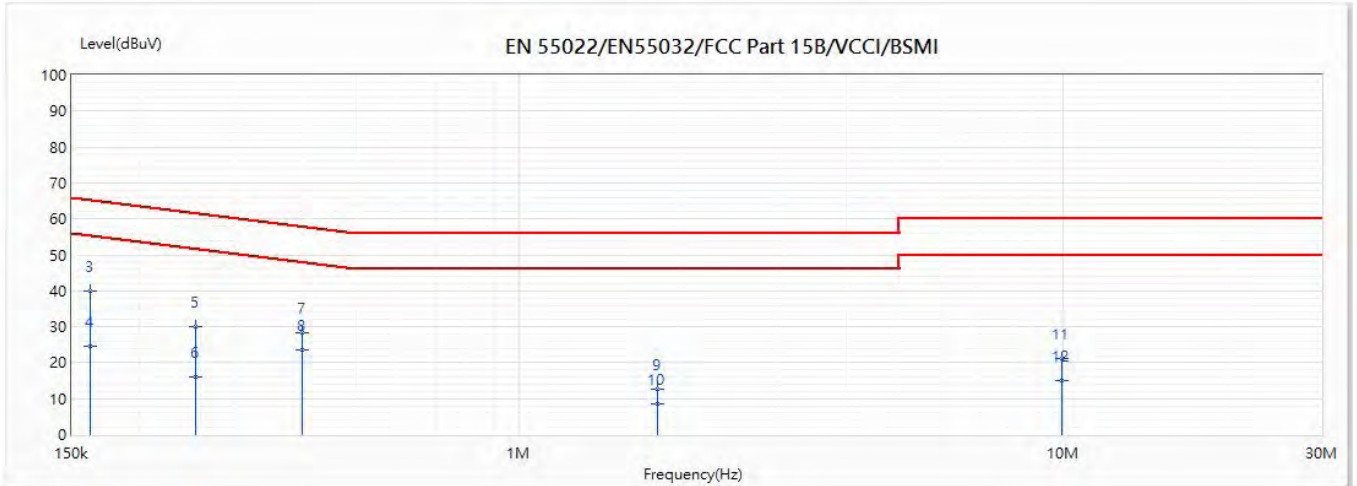

No	Frequency (MHz)	Emission Level (dBuV)	Limit (dBuV)	Margin (dB)	Reading Level (dBuV)	Correct Factor (dB)	Detector Type
1	0.1	16.94	66.00	-49.06	7.28	9.66	QP
2	0.1	8.36	56.00	-47.64	-1.30	9.66	AV
3	0.162	39.98	65.66	-25.68	30.32	9.66	QP
4	0.162	24.54	55.66	-31.12	14.87	9.66	AV
5	0.253	30.13	63.05	-32.92	20.45	9.68	QP
6	0.253	15.90	53.05	-37.15	6.22	9.68	AV
7	0.398	28.40	58.90	-30.50	18.70	9.71	QP
*8	0.398	23.41	48.90	-25.49	13.70	9.71	AV
9	1.801	12.67	56.00	-43.33	2.84	9.84	QP
10	1.801	8.41	46.00	-37.59	-1.42	9.84	AV
11	9.999	21.19	60.00	-38.81	11.09	10.10	QP
12	9.999	15.03	50.00	-34.97	4.93	10.10	AV

Remark:

1. "*" means this data is the worst emission level.
2. Emission Level = Reading Level + Correct Factor (Correct Factor = LISN Insertion Loss + Cable Loss).
3. Margin = Emission Level - Limit.

Model No	VE2A01	Site	SR2-H
Test Voltage	AC 120V/60Hz	Test Date	2020/5/13
Test Mode	Mode 1: Transmit_CDD	Engineer	Scott
Phase	L2	Temperature (°C)	24
Test Condition	802.11n(20M)_2437MHz	Humidity (%RH)	59

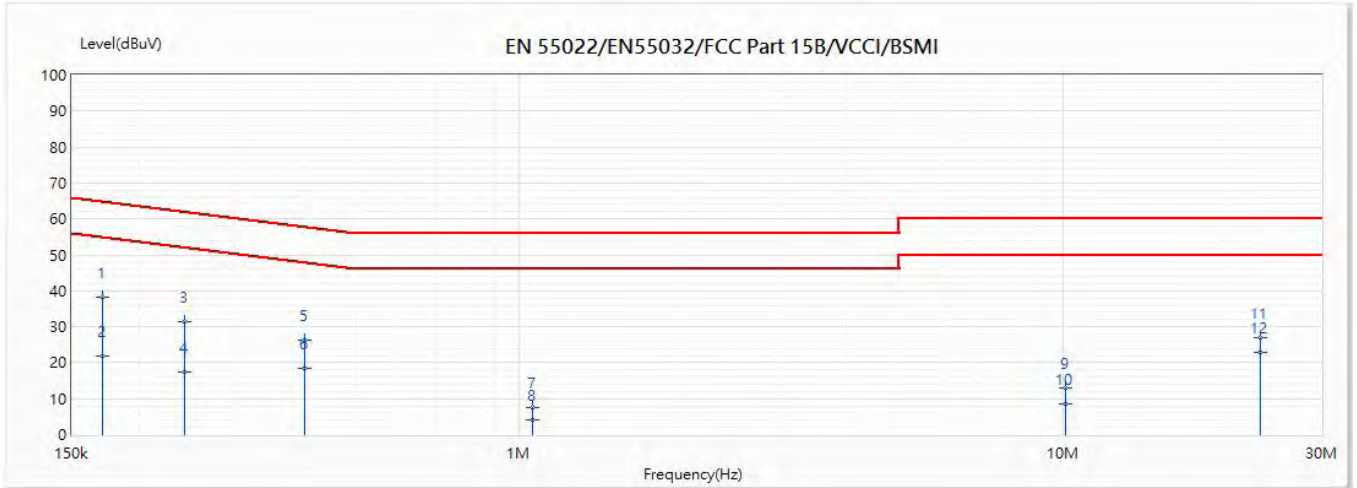

No	Frequency (MHz)	Emission Level (dBuV)	Limit (dBuV)	Margin (dB)	Reading Level (dBuV)	Correct Factor (dB)	Detector Type
1	0.171	38.37	65.41	-27.05	28.69	9.68	QP
2	0.171	21.89	55.41	-33.52	12.21	9.68	AV
3	0.242	31.46	63.38	-31.92	21.77	9.69	QP
4	0.242	17.30	53.38	-36.08	7.61	9.69	AV
5	0.403	26.45	58.77	-32.32	16.73	9.72	QP
6	0.403	18.34	48.77	-30.43	8.62	9.72	AV
7	1.06	7.66	56.00	-48.34	-2.17	9.82	QP
8	1.06	4.04	46.00	-41.96	-5.79	9.82	AV
9	10.131	12.94	60.00	-47.06	2.79	10.15	QP
10	10.131	8.51	50.00	-41.49	-1.64	10.15	AV
11	23.128	27.04	60.00	-32.96	16.53	10.52	QP
*12	23.128	22.97	50.00	-27.03	12.46	10.52	AV

Remark:

1. "*" means this data is the worst emission level.
2. Emission Level = Reading Level + Correct Factor (Correct Factor = LISN Insertion Loss + Cable Loss).
3. Margin = Emission Level - Limit.

Model No	VE2A01	Site	SR2-H
Test Voltage	AC 120V/60Hz	Test Date	2020/5/13
Test Mode	Mode 1: Transmit_CDD	Engineer	Scott
Phase	L1	Temperature (°C)	24
Test Condition	802.11n(40M)_2437MHz	Humidity (%RH)	59

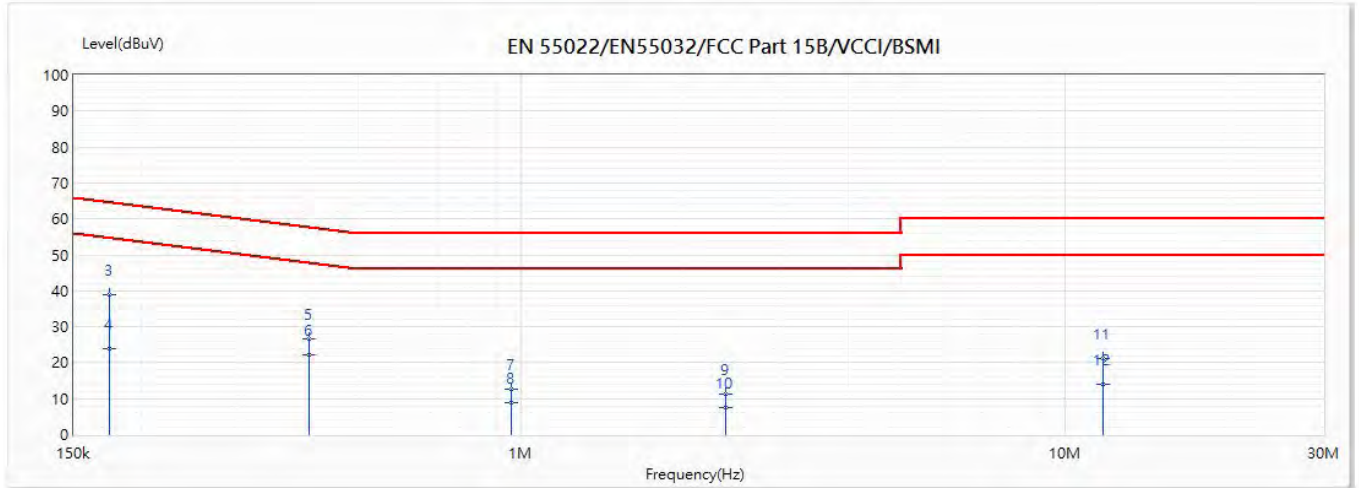

No	Frequency (MHz)	Emission Level (dBuV)	Limit (dBuV)	Margin (dB)	Reading Level (dBuV)	Correct Factor (dB)	Detector Type
1	0.1	14.78	66.00	-51.22	5.12	9.66	QP
2	0.1	6.62	56.00	-49.38	-3.04	9.66	AV
*3	0.175	38.78	65.29	-26.51	29.12	9.66	QP
4	0.175	23.89	55.29	-31.40	14.23	9.66	AV
5	0.406	26.49	58.68	-32.19	16.78	9.71	QP
6	0.406	22.09	48.68	-26.60	12.37	9.71	AV
7	0.96	12.51	56.00	-43.49	2.70	9.81	QP
8	0.96	8.76	46.00	-37.24	-1.05	9.81	AV
9	2.373	11.25	56.00	-44.75	1.40	9.85	QP
10	2.373	7.36	46.00	-38.64	-2.49	9.85	AV
11	11.768	21.05	60.00	-38.95	10.92	10.13	QP
12	11.768	13.91	50.00	-36.09	3.78	10.13	AV

Remark:

1. "*" means this data is the worst emission level.
2. Emission Level = Reading Level + Correct Factor (Correct Factor = LISN Insertion Loss + Cable Loss).
3. Margin = Emission Level - Limit.

Model No	VE2A01	Site	SR2-H
Test Voltage	AC 120V/60Hz	Test Date	2020/5/13
Test Mode	Mode 1: Transmit_CDD	Engineer	Scott
Phase	L2	Temperature (°C)	24
Test Condition	802.11n(40M)_2437MHz	Humidity (%RH)	59

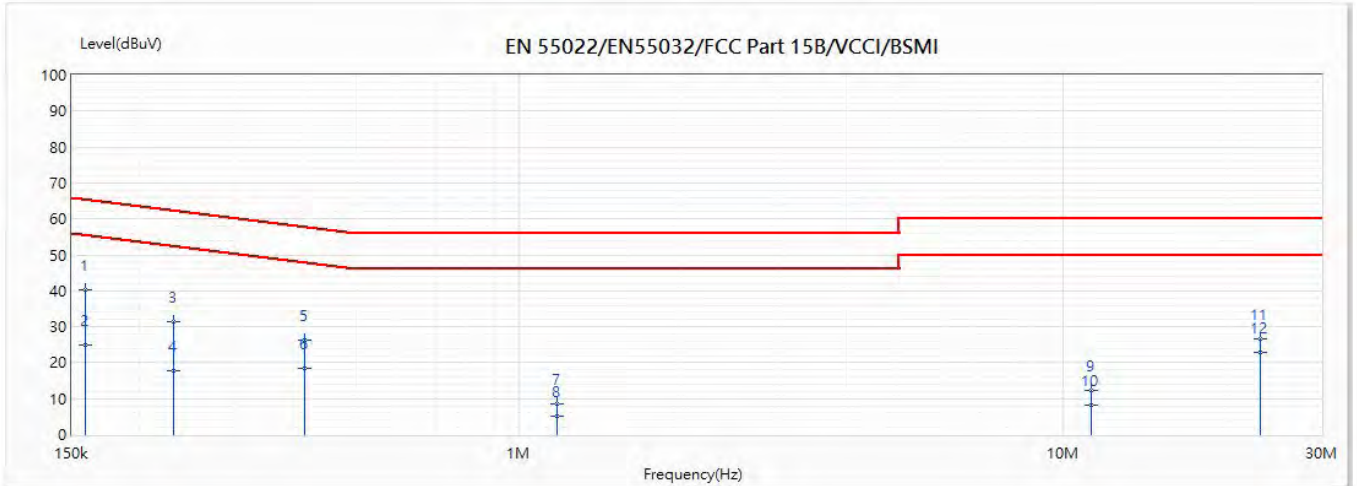

No	Frequency (MHz)	Emission Level (dBuV)	Limit (dBuV)	Margin (dB)	Reading Level (dBuV)	Correct Factor (dB)	Detector Type
*1	0.159	40.41	65.75	-25.34	30.73	9.68	QP
2	0.159	24.83	55.75	-30.93	15.15	9.68	AV
3	0.231	31.42	63.70	-32.27	21.74	9.69	QP
4	0.231	17.84	53.70	-35.85	8.15	9.69	AV
5	0.403	26.28	58.78	-32.51	16.56	9.72	QP
6	0.403	18.32	48.78	-30.47	8.60	9.72	AV
7	1.172	8.55	56.00	-47.45	-1.28	9.82	QP
8	1.172	5.06	46.00	-40.94	-4.77	9.82	AV
9	11.269	12.15	60.00	-47.85	1.96	10.19	QP
10	11.269	8.19	50.00	-41.81	-2.00	10.19	AV
11	23.129	26.71	60.00	-33.29	16.20	10.52	QP
12	23.129	22.80	50.00	-27.20	12.29	10.52	AV

Remark:

1. "*" means this data is the worst emission level.
2. Emission Level = Reading Level + Correct Factor (Correct Factor = LISN Insertion Loss + Cable Loss).
3. Margin = Emission Level - Limit.

4. Maximum conducted output power

4.1. Test Setup

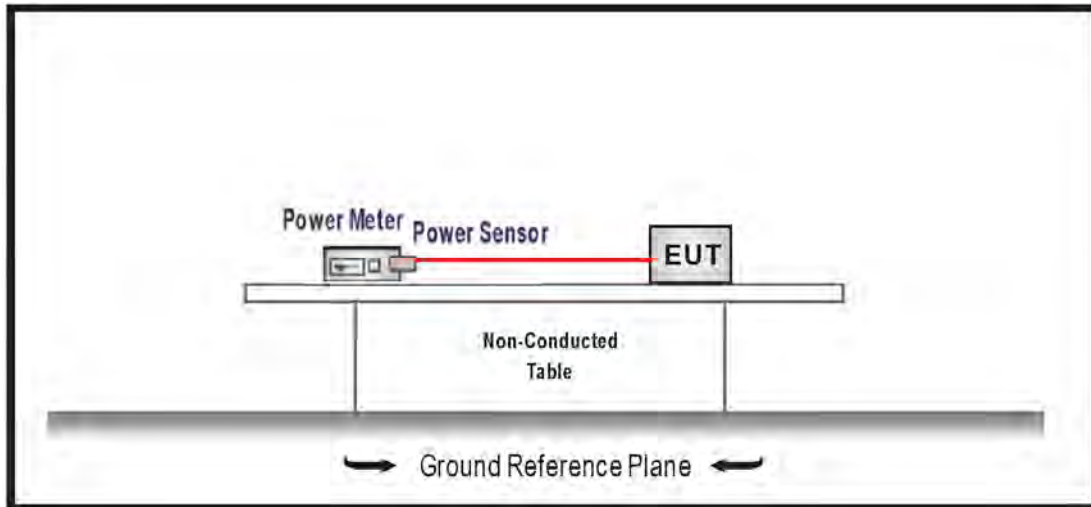

4.2. Test procedures

The EUT was tested according to DTS test procedure of KDB 558074 D01 V05r02 Measurement to FCC 47CFR 15.247 requirements.

4.3. Limits

The maximum peak power shall be less 1 Watt.

4.4. Test Specification

According to FCC Part 15 Subpart C Paragraph 15.247: 2019

4.5. Test Result

Product	Venation E2 IoT Gateway		
Test Item	Maximum conducted output power		
Test Mode	Mode 1: Transmit_CDD		
Date of Test	2020/05/12 ~ 2021/06/16	Test Site	SR12-H
Temperature(°C)	21~27	Humidity (%RH)	54~73

IEEE 802.11b (ANT 0)			
Channel No.	Frequency (MHz)	Average Power (dBm)	Limit (dBm)
1	2412	7.360	≤30
6	2437	7.010	≤30
10	2457	7.130	≤30
11	2462	6.610	≤30

The worst emission of data rate is 1 Mbps

Maximum conducted output power (dBm)						
Channel No.	Frequency (MHz)	Data Rate (Mbps)				Limit (dBm)
		1	2	5.5	11	
1	2412	7.360	--	--	--	≤30
6	2437	7.010	6.870	6.740	6.600	≤30
10	2457	7.130	--	--	--	≤30
11	2462	6.610	--	--	--	≤30

Product	Venation E2 IoT Gateway		
Test Item	Maximum conducted output power		
Test Mode	Mode 1: Transmit_CDD		
Date of Test	2020/05/12 ~ 2021/06/16	Test Site	SR12-H
Temperature(°C)	21~27	Humidity (%RH)	54~73

IEEE 802.11b (ANT 1)			
Channel No.	Frequency (MHz)	Average Power (dBm)	Limit (dBm)
1	2412	7.390	≤30
6	2437	7.660	≤30
10	2457	7.750	≤30
11	2462	6.560	≤30

The worst emission of data rate is 1 Mbps

Maximum conducted output power (dBm)						
Channel No.	Frequency (MHz)	Data Rate (Mbps)				Limit (dBm)
		1	2	5.5	11	
1	2412	7.390	--	--	--	≤30
6	2437	7.660	7.530	7.390	7.250	≤30
10	2457	7.750	--	--	--	≤30
11	2462	6.560	--	--	--	≤30

Product	Venation E2 IoT Gateway		
Test Item	Maximum conducted output power		
Test Mode	Mode 1: Transmit_CDD		
Date of Test	2020/05/12 ~ 2021/06/16	Test Site	SR12-H
Temperature(°C)	21~27	Humidity (%RH)	54~73

IEEE 802.11b (ANT 0+1)			
Channel No.	Frequency (MHz)	Average Power (dBm)	Limit (dBm)
1	2412	10.385	≤ 30
6	2437	10.357	≤ 30
10	2457	10.461	≤ 30
11	2462	9.595	≤ 30

Product	Venation E2 IoT Gateway		
Test Item	Maximum conducted output power		
Test Mode	Mode 1: Transmit_CDD		
Date of Test	2020/05/12 ~ 2021/06/16	Test Site	SR12-H
Temperature(°C)	21~27	Humidity (%RH)	54~73

IEEE 802.11g (ANT 0)			
Channel No.	Frequency (MHz)	Average Power (dBm)	Limit (dBm)
1	2412	14.79	≤30
6	2437	14.35	≤30
10	2457	14.83	≤30
11	2462	13.34	≤30

The worst emission of data rate is 6Mbps

Maximum conducted output power (dBm)										
Channel No	Frequency (MHz)	Data Rate (Mbps)								Limit (dBm)
		6	9	12	18	24	36	48	54	
1	2412	14.790	--	--	--	--	--	--	--	≤30
6	2437	14.350	14.210	14.070	13.930	13.780	13.630	13.490	13.350	≤30
10	2457	14.830	--	--	--	--	--	--	--	≤30
11	2462	13.340	--	--	--	--	--	--	--	≤30

Product	Venation E2 IoT Gateway		
Test Item	Maximum conducted output power		
Test Mode	Mode 1: Transmit_CDD		
Date of Test	2020/05/12 ~ 2021/06/16	Test Site	SR12-H
Temperature(°C)	21~27	Humidity (%RH)	54~73

IEEE 802.11g (ANT 1)			
Channel No.	Frequency (MHz)	Average Power (dBm)	Limit (dBm)
1	2412	15.21	≤30
6	2437	14.83	≤30
10	2457	15.09	≤30
11	2462	13.77	≤30

The worst emission of data rate is 6Mbps

Maximum conducted output power (dBm)										
Channel No	Frequency (MHz)	Data Rate (Mbps)								Limit (dBm)
		6	9	12	18	24	36	48	54	
1	2412	15.210	--	--	--	--	--	--	--	≤30
6	2437	14.830	14.690	14.550	14.410	14.280	14.140	14.010	13.870	≤30
10	2457	15.090	--	--	--	--	--	--	--	≤30
11	2462	13.770	--	--	--	--	--	--	--	≤30

Product	Venation E2 IoT Gateway		
Test Item	Maximum conducted output power		
Test Mode	Mode 1: Transmit_CDD		
Date of Test	2020/05/12 ~ 2021/06/16	Test Site	SR12-H
Temperature(°C)	21~27	Humidity (%RH)	54~73

IEEE 802.11g (ANT 0+1)			
Channel No.	Frequency (MHz)	Average Power (dBm)	Limit (dBm)
1	2412	18.015	≤ 30
6	2437	17.607	≤ 30
10	2457	17.972	≤ 30
11	2462	16.571	≤ 30

Product	Venation E2 IoT Gateway		
Test Item	Maximum conducted output power		
Test Mode	Mode 1: Transmit _CDD		
Date of Test	2020/05/12	Test Site	SR12-H
Temperature(°C)	23	Humidity (%RH)	60

IEEE 802.11n (20M) (ANT 0)			
Channel No.	Frequency (MHz)	Average Power (dBm)	Limit (dBm)
1	2412	14.02	≤30
6	2437	13.74	≤30
11	2462	13.93	≤30

The worst emission of data rate is MCS 0

Maximum conducted output power (dBm)										
Channel No	Frequency (MHz)	MCS Index								Limit (dBm)
		0	1	2	3	4	5	6	7	
1	2412	14.020	--	--	--	--	--	--	--	≤30
6	2437	13.740	13.590	13.450	13.300	13.160	13.030	12.890	12.740	≤30
11	2462	13.930	--	--	--	--	--	--	--	≤30

Product	Venation E2 IoT Gateway		
Test Item	Maximum conducted output power		
Test Mode	Mode 1: Transmit _CDD		
Date of Test	2020/05/12	Test Site	SR12-H
Temperature(°C)	23	Humidity (%RH)	60

IEEE 802.11n (20M) (ANT 1)			
Channel No.	Frequency (MHz)	Average Power (dBm)	Limit (dBm)
1	2412	14.24	≤30
6	2437	14.20	≤30
11	2462	14.39	≤30

The worst emission of data rate is MCS 0

Maximum conducted output power (dBm)										
Channel No	Frequency (MHz)	MCS Index								Limit (dBm)
		0	1	2	3	4	5	6	7	
1	2412	14.240	--	--	--	--	--	--	--	≤30
6	2437	14.200	14.060	13.910	13.760	13.610	13.470	13.330	13.190	≤30
11	2462	14.390	--	--	--	--	--	--	--	≤30

Product	Venation E2 IoT Gateway		
Test Item	Maximum conducted output power		
Test Mode	Mode 1: Transmit_CDD		
Date of Test	2020/05/12	Test Site	SR12-H
Temperature(°C)	23	Humidity (%RH)	60

IEEE 802.11n (20M) (ANT 0+1)			
Channel No.	Frequency (MHz)	Average Power (dBm)	Limit (dBm)
1	2412	17.142	≤ 30
6	2437	16.986	≤ 30
11	2462	17.176	≤ 30

Product	Venation E2 IoT Gateway		
Test Item	Maximum conducted output power		
Test Mode	Mode 1: Transmit _CDD		
Date of Test	2020/05/12	Test Site	SR12-H
Temperature(°C)	23	Humidity (%RH)	60

IEEE 802.11n (40M) (ANT 0)			
Channel No.	Frequency (MHz)	Average Power (dBm)	Limit (dBm)
3	2422	12.92	≤30
6	2437	14.69	≤30
9	2452	14.94	≤30

The worst emission of data rate is MCS 0

Maximum conducted output power (dBm)										
Channel No	Frequency (MHz)	MCS Index								Limit (dBm)
		0	1	2	3	4	5	6	7	
3	2422	12.920	--	--	--	--	--	--	--	≤30
6	2437	14.690	14.560	14.410	14.280	14.130	13.990	13.860	13.720	≤30
9	2452	14.940	--	--	--	--	--	--	--	≤30

Product	Venation E2 IoT Gateway		
Test Item	Maximum conducted output power		
Test Mode	Mode 1: Transmit_CDD		
Date of Test	2020/05/12	Test Site	SR12-H
Temperature(°C)	23	Humidity (%RH)	60

IEEE 802.11n (40M) (ANT 1)			
Channel No.	Frequency (MHz)	Average Power (dBm)	Limit (dBm)
3	2422	13.23	≤30
6	2437	15.22	≤30
9	2452	15.42	≤30

The worst emission of data rate is MCS 0

Maximum conducted output power (dBm)										
Channel No	Frequency (MHz)	MCS Index								Limit (dBm)
		0	1	2	3	4	5	6	7	
3	2422	13.230	--	--	--	--	--	--	--	≤30
6	2437	15.220	15.070	14.940	14.810	14.670	14.530	14.400	14.250	≤30
9	2452	15.420	--	--	--	--	--	--	--	≤30

Product	Venation E2 IoT Gateway		
Test Item	Maximum conducted output power		
Test Mode	Mode 1: Transmit_CDD		
Date of Test	2020/05/12	Test Site	SR12-H
Temperature(°C)	23	Humidity (%RH)	60

IEEE 802.11n (40M) (ANT 0+1)			
Channel No.	Frequency (MHz)	Average Power (dBm)	Limit (dBm)
3	2422	16.088	≤ 30
6	2437	17.973	≤ 30
9	2452	18.197	≤ 30

5. Radiated Emission

5.1. Test Setup

Under 30MHz Test Setup:

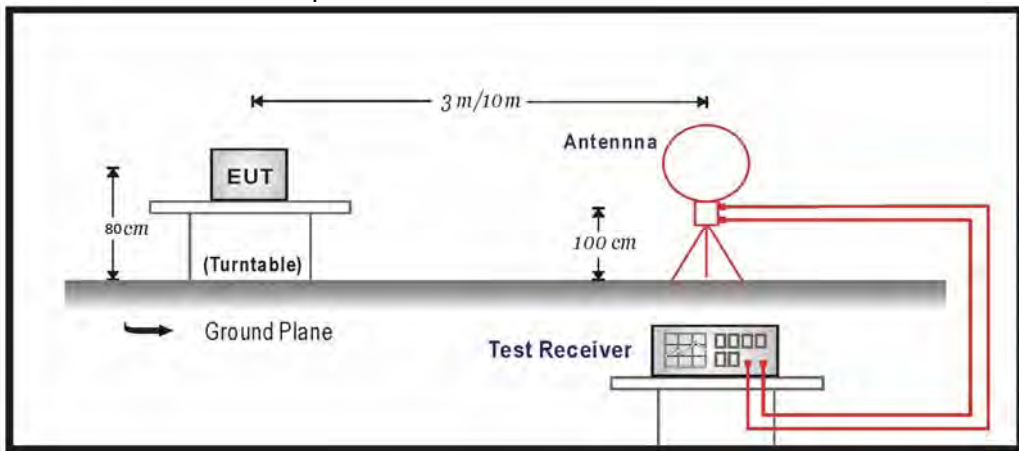

Under 1GHz Test Setup:

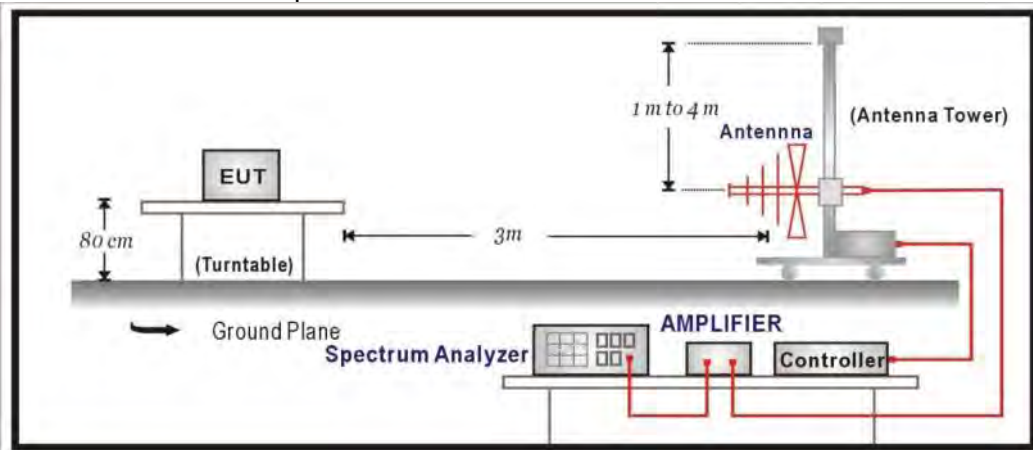

Above 1GHz Test Setup:

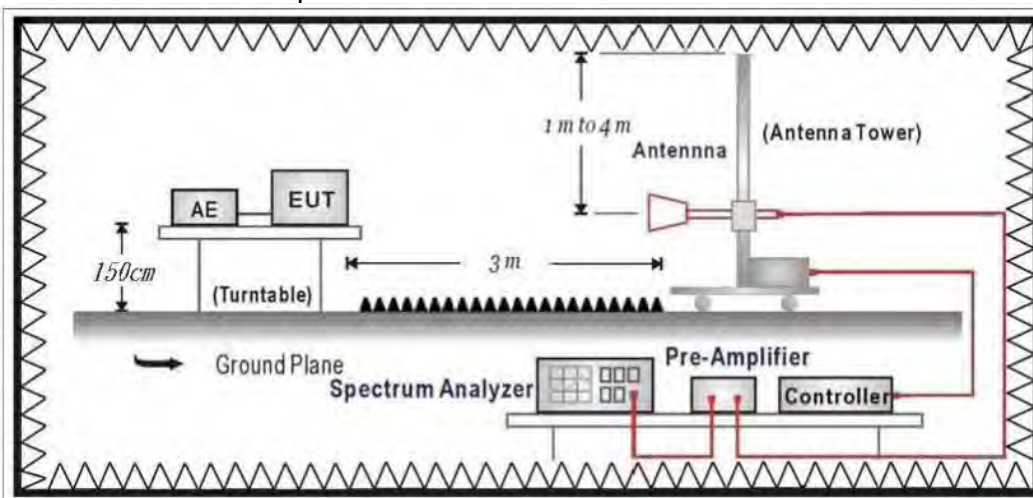

5.2. Limits

Emissions radiated outside of the specified frequency bands, except for harmonics, shall be attenuated by at least 20dB below the level of the fundamental or to the general radiated emission limits in paragraph 15.209, whichever is the lesser attenuation.

FCC Part 15 Subpart C Paragraph 15.209 Limits		
Frequency (MHz)	uV/m	dBuV/m
30-88	100	40
88-216	150	43.5
216-960	200	46
Above 960	500	54

Remarks: E field strength (dBuV/m) = 20 log E field strength (uV/m)

5.3. Test Procedure

The EUT was setup according to ANSI C63.10:2013 and tested according to DTS test procedure of KDB 558074 D01 V05r02 for compliance to FCC 47CFR 15.247 requirements. The EUT and its simulators are placed on a turn table which is 1.5 meter above ground (under 1GHz) or 1.5 meter above ground (above 1GHz). The turn table can rotate 360 degrees to determine the position of the maximum emission level.

The antenna can move up and down between 1 meter and 4 meters to find out the maximum emission level.

Both horizontal and vertical polarization of the antenna are set on measurement. In order to find the maximum emission, all of the interface cables must be manipulated according to ANSI C63.10:2013 on radiated measurement.

On any frequency or frequencies below or equal to 1000 MHz, the limits shown are based on measuring equipment employing a quasi-peak detector function and on any frequency or frequencies above 1000 MHz the radiated limits shown are based upon the use of measurement instrumentation employing an average detector function. When average radiated emission measurement are included emission measurement below 1000 MHz, there also is a limit on the radio frequency emissions, as measured using instrumentation with a peak detector function, corresponding to 20 dB above the maximum permitted average limit. The bandwidth below 1GHz setting on the field strength meter is 120 kHz and above 1GHz is 1MHz.

5.4. Test Specification

According to FCC Part 15 Subpart C Paragraph 15.247: 2019

5.5. Test Result

30MHz-1GHz Spurious

Model No	VE2A01	Site	CB4-H
Test Voltage	AC 120V/60Hz	Test Date	2020/5/8
Test Mode	Mode 1: Transmit_CDD	Engineer	Lion
Polarity	Horizontal	Temperature (°C)	24.0
Test Condition	802.11b_Ch 6_2.437G	Humidity (%RH)	56.0

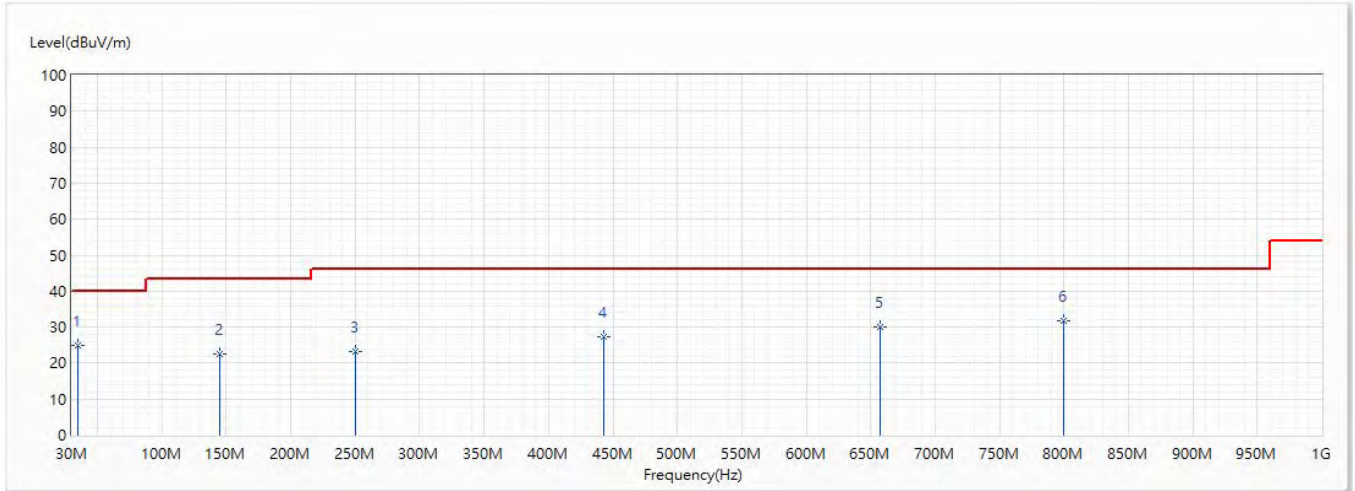

No	Frequency (MHz)	Emission Level (dBuV/m)	Limit (dBuV/m)	Margin (dB)	Reading Level (dBuV)	Correct Factor (dB/m)	Detector Type
1	35.093	25.04	40.00	-14.96	21.91	3.13	QP
2	145.188	22.38	43.50	-21.12	26.24	-3.86	QP
3	249.948	23.31	46.00	-22.69	25.66	-2.35	QP
4	442.493	27.37	46.00	-18.63	24.95	2.42	QP
5	657.59	30.03	46.00	-15.97	24.84	5.19	QP
* 6	800.059	31.71	46.00	-14.29	24.84	6.87	QP

Note:

1. All reading levels is Quasi-Peak value.
2. “ * ”, means this data is the worst value.
3. Emission Level = Reading Level + Correct Factor
4. The emission under 30MHz were not included is because their levels are lower than 20dB from limit.

Model No	VE2A01	Site	CB4-H
Test Voltage	AC 120V/60Hz	Test Date	2020/5/8
Test Mode	Mode 1: Transmit_CDD	Engineer	Lion
Polarity	Vertical	Temperature (°C)	24.0
Test Condition	802.11b_Ch 6_2.437G	Humidity (%RH)	56.0

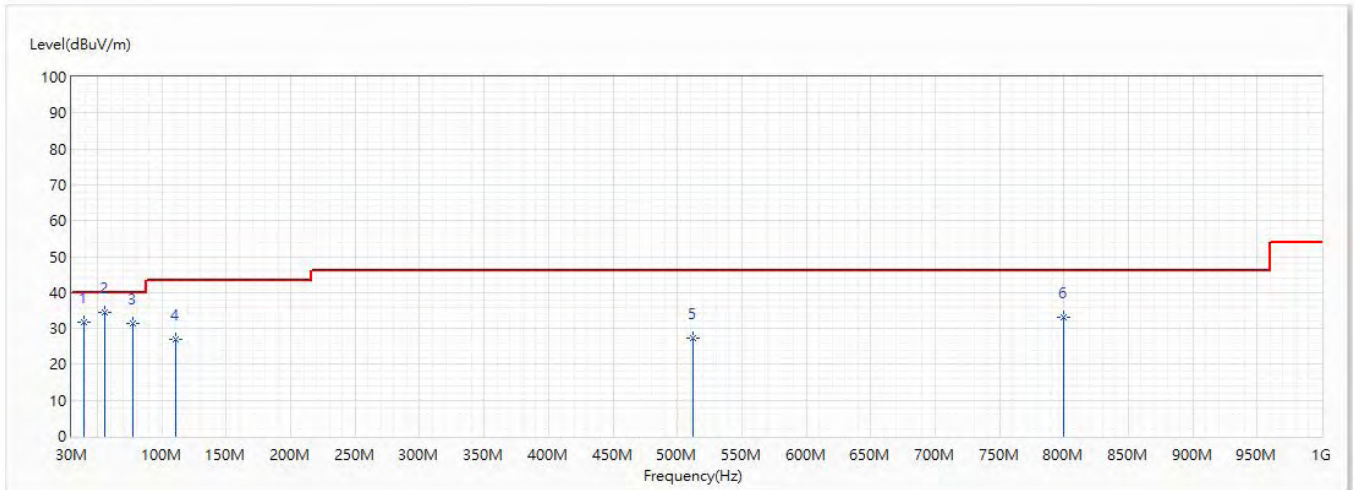

No	Frequency (MHz)	Emission Level (dBuV/m)	Limit (dBuV/m)	Margin (dB)	Reading Level (dBuV)	Correct Factor (dB/m)	Detector Type
1	39.458	31.78	40.00	-8.22	29.06	2.72	QP
* 2	55.826	34.45	40.00	-5.55	42.10	-7.65	QP
3	77.166	31.53	40.00	-8.47	39.83	-8.30	QP
4	110.753	26.82	43.50	-16.68	31.16	-4.34	QP
5	512.575	27.38	46.00	-18.62	23.80	3.58	QP
6	800.059	32.99	46.00	-13.01	26.12	6.87	QP

Note:

1. All reading levels is Quasi-Peak value.
2. “ * ”, means this data is the worst value.
3. Emission Level = Reading Level + Correct Factor
4. The emission under 30MHz were not included is because their levels are lower than 20dB from limit.

Model No	VE2A01	Site	CB4-H
Test Voltage	AC 120V/60Hz	Test Date	2020/5/8
Test Mode	Mode 1: Transmit_CDD	Engineer	Lion
Polarity	Horizontal	Temperature (°C)	24.0
Test Condition	802.11g_Ch 6_2.437G	Humidity (%RH)	56.0

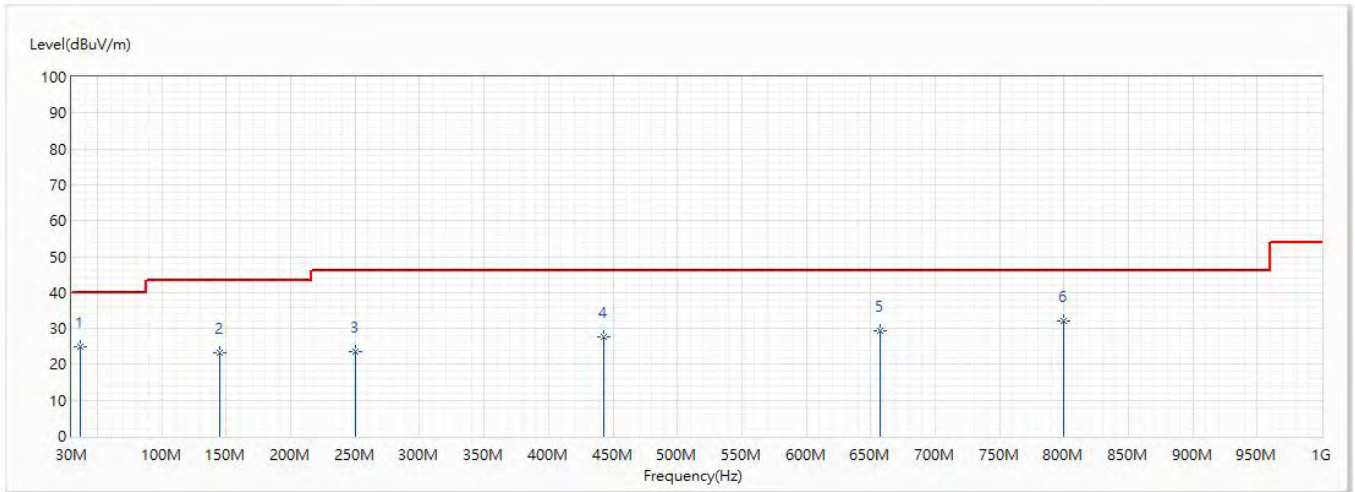

No	Frequency (MHz)	Emission Level (dBuV/m)	Limit (dBuV/m)	Margin (dB)	Reading Level (dBuV)	Correct Factor (dB/m)	Detector Type
1	36.911	24.76	40.00	-15.24	21.80	2.96	QP
2	145.309	23.06	43.50	-20.44	26.91	-3.85	QP
3	250.069	23.52	46.00	-22.48	25.86	-2.34	QP
4	442.493	27.48	46.00	-18.52	25.06	2.42	QP
5	657.469	29.43	46.00	-16.57	24.26	5.17	QP
* 6	800.059	32.07	46.00	-13.93	25.20	6.87	QP

Note:

1. All reading levels is Quasi-Peak value.
2. “ * ”, means this data is the worst value.
3. Emission Level = Reading Level + Correct Factor
4. The emission under 30MHz were not included is because their levels are lower than 20dB from limit.

Model No	VE2A01	Site	CB4-H
Test Voltage	AC 120V/60Hz	Test Date	2020/5/8
Test Mode	Mode 1: Transmit_CDD	Engineer	Lion
Polarity	Vertical	Temperature (°C)	24.0
Test Condition	802.11g_Ch 6_2.437G	Humidity (%RH)	56.0

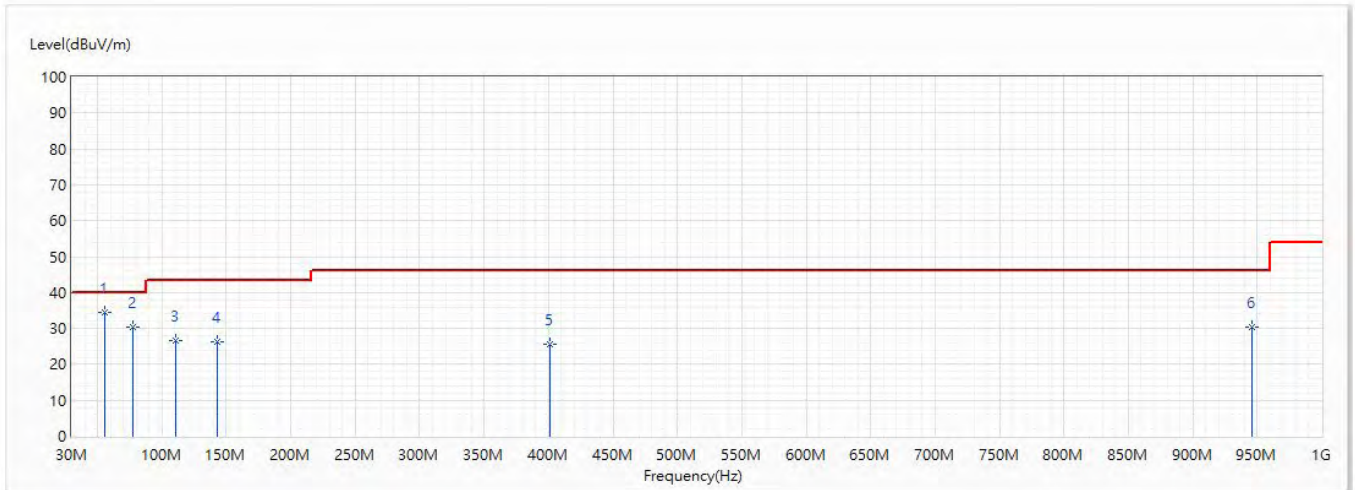

No	Frequency (MHz)	Emission Level (dBuV/m)	Limit (dBuV/m)	Margin (dB)	Reading Level (dBuV)	Correct Factor (dB/m)	Detector Type
* 1	55.948	34.50	40.00	-5.50	42.18	-7.68	QP
2	77.166	30.21	40.00	-9.79	38.51	-8.30	QP
3	110.753	26.54	43.50	-16.96	30.88	-4.34	QP
4	143.248	26.17	43.50	-17.33	30.06	-3.89	QP
5	401.025	25.57	46.00	-20.43	23.88	1.69	QP
6	945.438	30.40	46.00	-15.60	21.63	8.77	QP

Note:

1. All reading levels is Quasi-Peak value.
2. “ * ”, means this data is the worst value.
3. Emission Level = Reading Level + Correct Factor
4. The emission under 30MHz were not included is because their levels are lower than 20dB from limit.

Model No	VE2A01	Site	CB4-H
Test Voltage	AC 120V/60Hz	Test Date	2020/5/8
Test Mode	Mode 1: Transmit_CDD	Engineer	Lion
Polarity	Horizontal	Temperature (°C)	24.0
Test Condition	802.11n_20M_Ch 6_2.437G	Humidity (%RH)	56.0

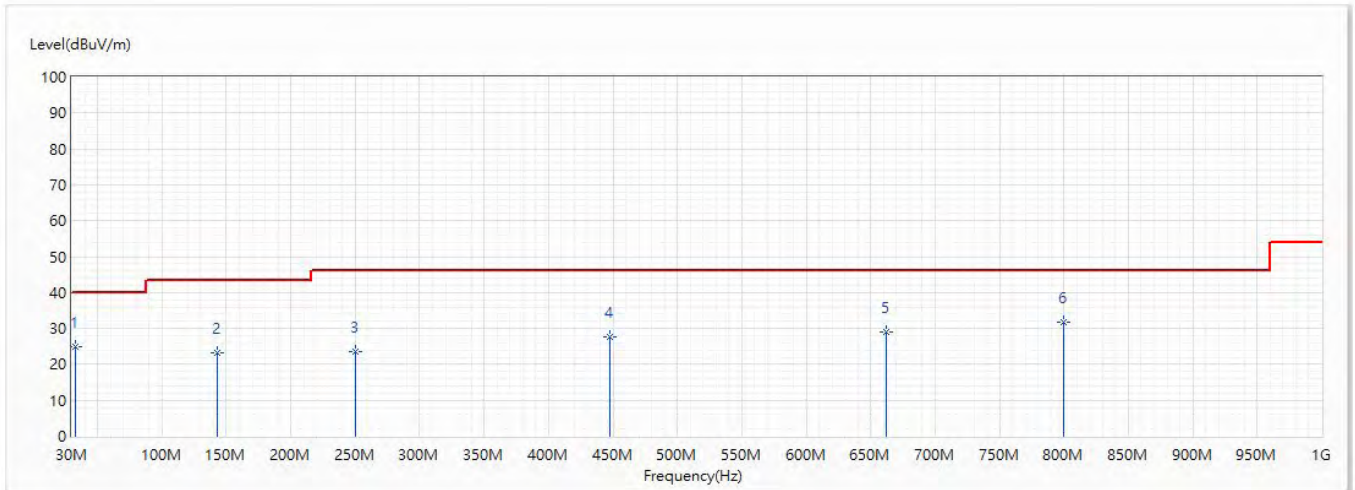

No	Frequency (MHz)	Emission Level (dBuV/m)	Limit (dBuV/m)	Margin (dB)	Reading Level (dBuV)	Correct Factor (dB/m)	Detector Type
1	32.91	24.75	40.00	-15.25	21.43	3.32	QP
2	143.248	23.15	43.50	-20.35	27.04	-3.89	QP
3	249.948	23.42	46.00	-22.58	25.77	-2.35	QP
4	447.585	27.71	46.00	-18.29	25.19	2.52	QP
5	662.561	29.00	46.00	-17.00	23.77	5.23	QP
* 6	800.059	31.91	46.00	-14.09	25.04	6.87	QP

Note:

1. All reading levels is Quasi-Peak value.
2. “ * ”, means this data is the worst value.
3. Emission Level = Reading Level + Correct Factor
4. The emission under 30MHz were not included is because their levels are lower than 20dB from limit.

Model No	VE2A01	Site	CB4-H
Test Voltage	AC 120V/60Hz	Test Date	2020/5/8
Test Mode	Mode 1: Transmit_CDD	Engineer	Lion
Polarity	Vertical	Temperature (°C)	24.0
Test Condition	802.11n_20M_Ch 6_2.437G	Humidity (%RH)	56.0

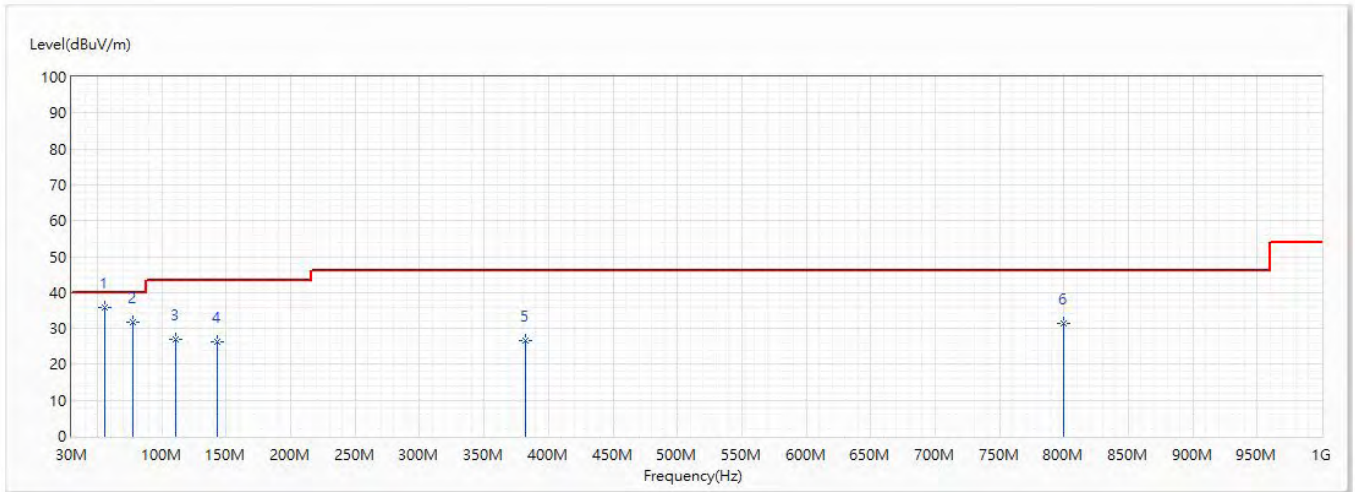

No	Frequency (MHz)	Emission Level (dBuV/m)	Limit (dBuV/m)	Margin (dB)	Reading Level (dBuV)	Correct Factor (dB/m)	Detector Type
* 1	55.948	35.91	40.00	-4.09	43.59	-7.68	QP
2	77.166	31.59	40.00	-8.41	39.89	-8.30	QP
3	110.753	26.86	43.50	-16.64	31.20	-4.34	QP
4	143.248	26.25	43.50	-17.25	30.14	-3.89	QP
5	382.474	26.57	46.00	-19.43	25.45	1.12	QP
6	800.059	31.49	46.00	-14.51	24.62	6.87	QP

Note:

1. All reading levels is Quasi-Peak value.
2. “ * ”, means this data is the worst value.
3. Emission Level = Reading Level + Correct Factor
4. The emission under 30MHz were not included is because their levels are lower than 20dB from limit.

Model No	VE2A01	Site	CB4-H
Test Voltage	AC 120V/60Hz	Test Date	2020/5/8
Test Mode	Mode 1: Transmit_CDD	Engineer	Lion
Polarity	Horizontal	Temperature (°C)	24.0
Test Condition	802.11n_40M_Ch 6_2.437G	Humidity (%RH)	56.0

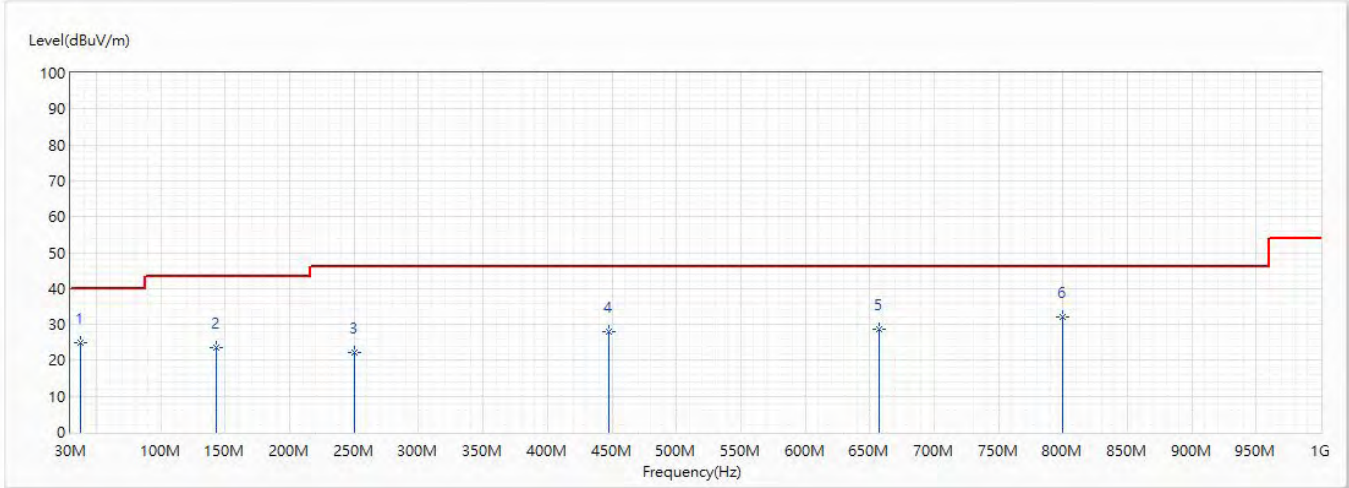

No	Frequency (MHz)	Emission Level (dBuV/m)	Limit (dBuV/m)	Margin (dB)	Reading Level (dBuV)	Correct Factor (dB/m)	Detector Type
1	37.396	24.96	40.00	-15.04	22.05	2.91	QP
2	143.248	23.72	43.50	-19.78	27.61	-3.89	QP
3	249.948	22.15	46.00	-23.85	24.50	-2.35	QP
4	447.585	28.04	46.00	-17.96	25.52	2.52	QP
5	657.59	28.62	46.00	-17.38	23.43	5.19	QP
* 6	800.059	32.14	46.00	-13.86	25.27	6.87	QP

Note:

1. All reading levels is Quasi-Peak value.
2. “ * ”, means this data is the worst value.
3. Emission Level = Reading Level + Correct Factor
4. The emission under 30MHz were not included is because their levels are lower than 20dB from limit.

Model No	VE2A01	Site	CB4-H
Test Voltage	AC 120V/60Hz	Test Date	2020/5/8
Test Mode	Mode 1: Transmit_CDD	Engineer	Lion
Polarity	Vertical	Temperature (°C)	24.0
Test Condition	802.11n_40M_Ch 6_2.437G	Humidity (%RH)	56.0

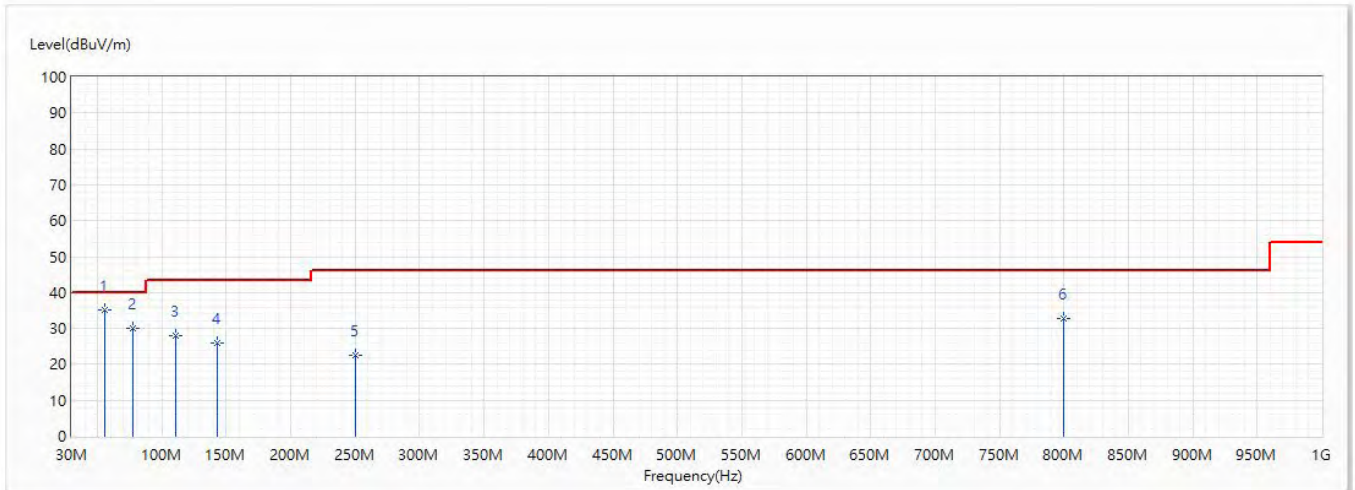

No	Frequency (MHz)	Emission Level (dBuV/m)	Limit (dBuV/m)	Margin (dB)	Reading Level (dBuV)	Correct Factor (dB/m)	Detector Type
* 1	55.948	35.11	40.00	-4.89	42.79	-7.68	QP
2	77.166	30.07	40.00	-9.93	38.37	-8.30	QP
3	110.753	28.08	43.50	-15.42	32.42	-4.34	QP
4	143.248	25.92	43.50	-17.58	29.81	-3.89	QP
5	249.948	22.42	46.00	-23.58	24.77	-2.35	QP
6	800.059	32.64	46.00	-13.36	25.77	6.87	QP

Note:

1. All reading levels is Quasi-Peak value.
2. " * ", means this data is the worst value.
3. Emission Level = Reading Level + Correct Factor
4. The emission under 30MHz were not included is because their levels are lower than 20dB from limit.

Above 1GHz Spurious

Model No	VE2A01	Site	CB4-H
Test Voltage	AC 120V/60Hz	Test Date	2020/5/6
Test Mode	Mode 1: Transmit_CDD	Engineer	Lion
Polarity	Horizontal	Temperature (°C)	24.0
Test Condition	802.11b_Ch 1_2.412G	Humidity (%RH)	56.0

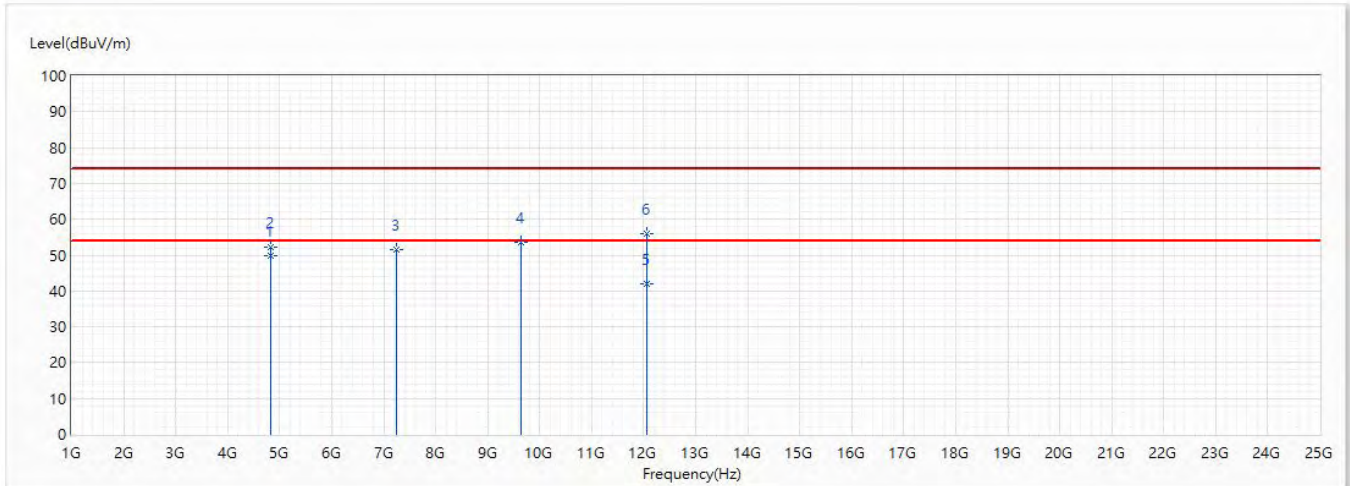

No	Frequency (MHz)	Emission Level (dBuV/m)	Limit (dBuV/m)	Margin (dB)	Reading Level (dBuV)	Correct Factor (dB/m)	Detector Type
* 1	4824	49.86	54.00	-4.14	51.39	-1.53	AV
2	4824	52.16	74.00	-21.84	53.69	-1.53	PK
3	7236	51.48	74.00	-22.52	45.31	6.17	PK
4	9648	53.55	74.00	-20.45	42.18	11.37	PK
5	12060	41.86	54.00	-12.14	28.37	13.49	AV
6	12060	55.92	74.00	-18.08	42.43	13.49	PK

Note:

- 1.All reading above 1GHz is performed with peak and/or average measurements as necessary.
2. “ * ”, means this data is the worst value.
- 3.Emission Level = Reading Level + Correct Factor.
- 4.The average measurement was not performed when the peak measured data under the limit of average detection.
- 5.The emission above 13GHz were not included is because their levels are lower than 20dB form limit.

Model No	VE2A01	Site	CB4-H
Test Voltage	AC 120V/60Hz	Test Date	2020/5/6
Test Mode	Mode 1: Transmit_CDD	Engineer	Lion
Polarity	Vertical	Temperature (°C)	24.0
Test Condition	802.11b_Ch 1_2.412G	Humidity (%RH)	56.0

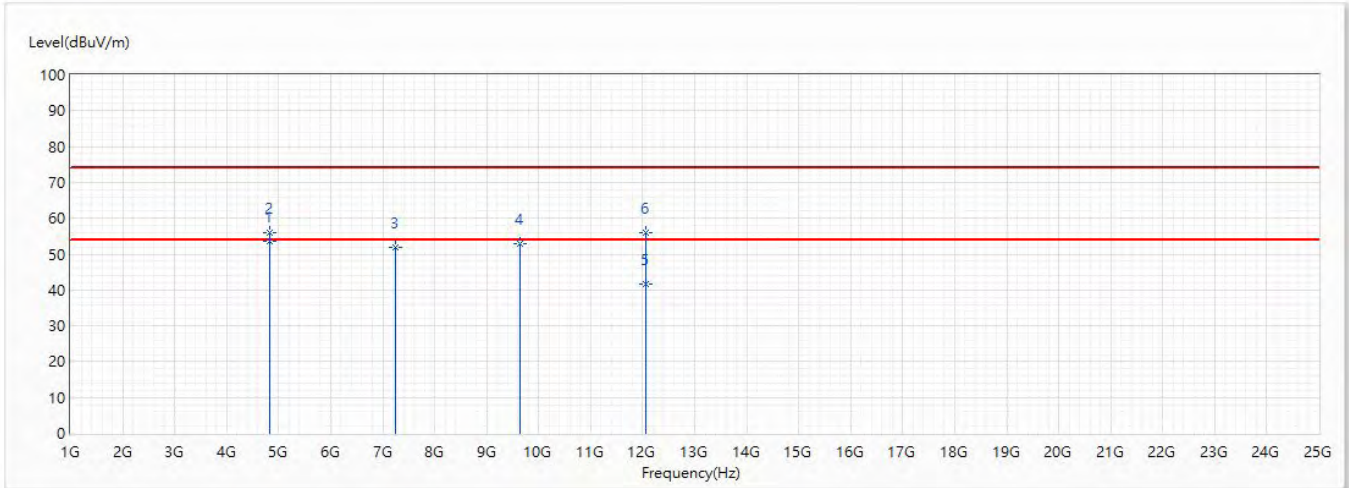

No	Frequency (MHz)	Emission Level (dBuV/m)	Limit (dBuV/m)	Margin (dB)	Reading Level (dBuV)	Correct Factor (dB/m)	Detector Type
* 1	4824	53.46	54.00	-0.54	54.99	-1.53	AV
2	4824	55.81	74.00	-18.19	57.34	-1.53	PK
3	7236	51.90	74.00	-22.10	45.73	6.17	PK
4	9648	53.06	74.00	-20.94	41.69	11.37	PK
5	12060	41.75	54.00	-12.25	28.26	13.49	AV
6	12060	56.04	74.00	-17.96	42.55	13.49	PK

Note:

- 1.All reading above 1GHz is performed with peak and/or average measurements as necessary.
2. “ * ”, means this data is the worst value.
- 3.Emission Level = Reading Level + Correct Factor.
- 4.The average measurement was not performed when the peak measured data under the limit of average detection.
- 5.The emission above 13GHz were not included is because their levels are lower than 20dB form limit.

Model No	VE2A01	Site	CB4-H
Test Voltage	AC 120V/60Hz	Test Date	2020/5/7
Test Mode	Mode 1: Transmit_CDD	Engineer	Lion
Polarity	Horizontal	Temperature (°C)	24.0
Test Condition	802.11b_Ch 6_2.437G	Humidity (%RH)	56.0

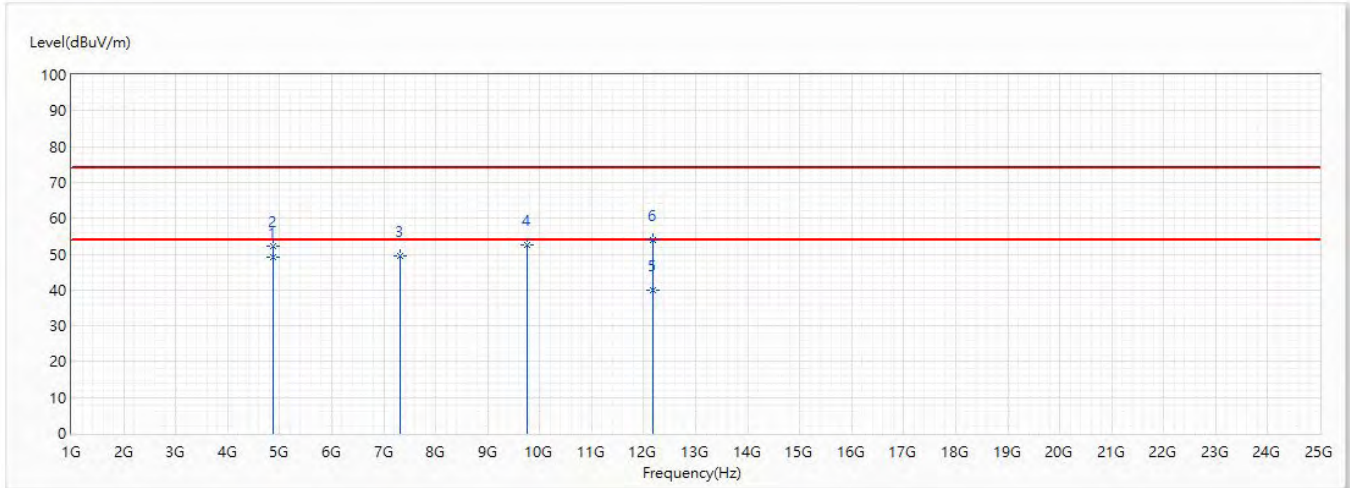

No	Frequency (MHz)	Emission Level (dBuV/m)	Limit (dBuV/m)	Margin (dB)	Reading Level (dBuV)	Correct Factor (dB/m)	Detector Type
* 1	4874	49.09	54.00	-4.91	50.42	-1.33	AV
2	4874	52.37	74.00	-21.63	53.70	-1.33	PK
3	7311	49.60	74.00	-24.40	43.18	6.42	PK
4	9748	52.62	74.00	-21.38	41.13	11.49	PK
5	12185	40.03	54.00	-13.97	26.75	13.28	AV
6	12185	54.07	74.00	-19.93	40.79	13.28	PK

Note:

- 1.All reading above 1GHz is performed with peak and/or average measurements as necessary.
2. “ * ”, means this data is the worst value.
- 3.Emission Level = Reading Level + Correct Factor.
- 4.The average measurement was not performed when the peak measured data under the limit of average detection.
- 5.The emission above 13GHz were not included is because their levels are lower than 20dB form limit.

Model No	VE2A01	Site	CB4-H
Test Voltage	AC 120V/60Hz	Test Date	2020/5/7
Test Mode	Mode 1: Transmit_CDD	Engineer	Lion
Polarity	Vertical	Temperature (°C)	24.0
Test Condition	802.11b_Ch 6_2.437G	Humidity (%RH)	56.0

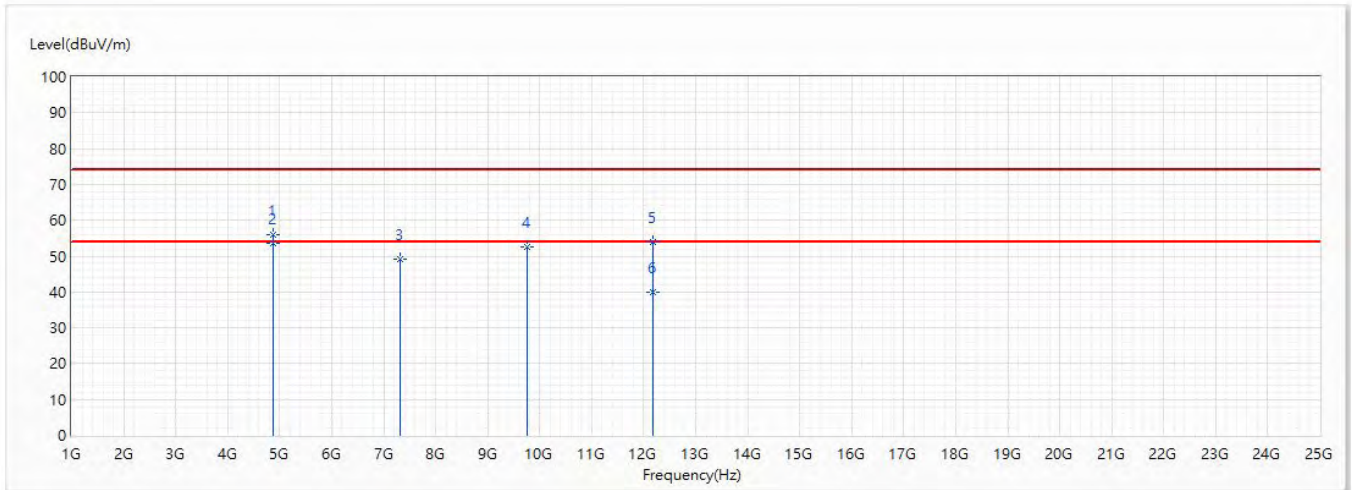

No	Frequency (MHz)	Emission Level (dBuV/m)	Limit (dBuV/m)	Margin (dB)	Reading Level (dBuV)	Correct Factor (dB/m)	Detector Type
1	4874	56.01	74.00	-17.99	57.34	-1.33	PK
* 2	4874	53.58	54.00	-0.42	54.91	-1.33	AV
3	7311	49.30	74.00	-24.70	42.88	6.42	PK
4	9748	52.42	74.00	-21.58	40.93	11.49	PK
5	12185	54.05	74.00	-19.95	40.77	13.28	PK
6	12185	40.03	54.00	-13.97	26.75	13.28	AV

Note:

- 1.All reading above 1GHz is performed with peak and/or average measurements as necessary.
2. “ * ”, means this data is the worst value.
- 3.Emission Level = Reading Level + Correct Factor.
- 4.The average measurement was not performed when the peak measured data under the limit of average detection.
- 5.The emission above 13GHz were not included is because their levels are lower than 20dB form limit.

Model No	VE2A01	Site	CB4-H
Test Voltage	AC 120V/60Hz	Test Date	2020/5/8
Test Mode	Mode 1: Transmit_CDD	Engineer	Lion
Polarity	Horizontal	Temperature (°C)	24.0
Test Condition	802.11b_Ch 11_2.462G	Humidity (%RH)	56.0

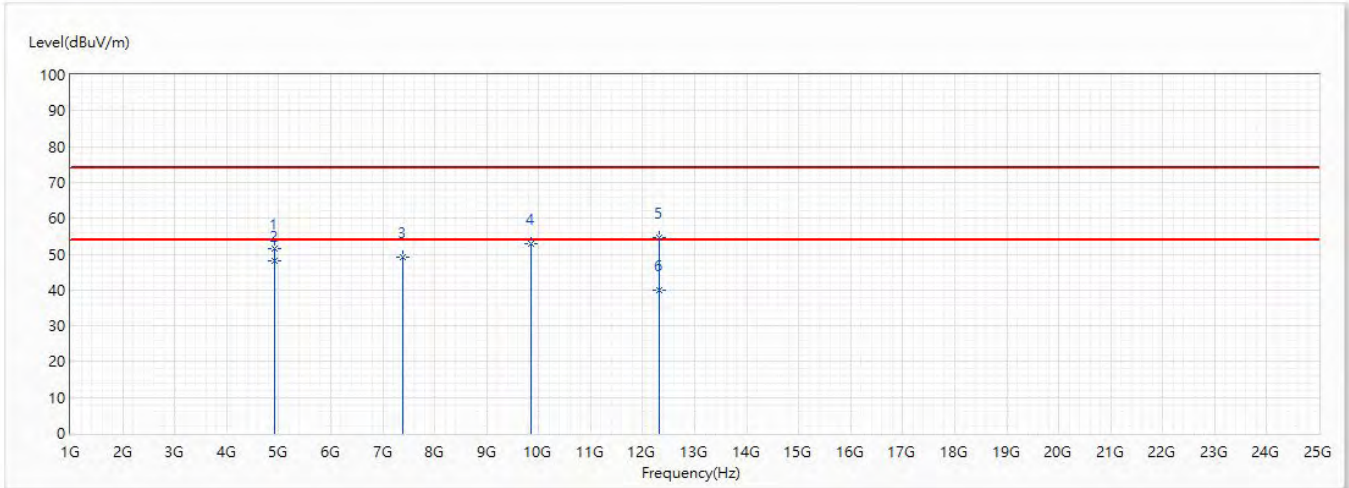

No	Frequency (MHz)	Emission Level (dBuV/m)	Limit (dBuV/m)	Margin (dB)	Reading Level (dBuV)	Correct Factor (dB/m)	Detector Type
1	4924	51.70	74.00	-22.30	52.83	-1.13	PK
* 2	4924	48.23	54.00	-5.77	49.36	-1.13	AV
3	7386	49.23	74.00	-24.77	42.57	6.66	PK
4	9848	52.83	74.00	-21.17	41.28	11.55	PK
5	12310	54.64	74.00	-19.36	41.59	13.05	PK
6	12310	39.84	54.00	-14.16	26.79	13.05	AV

Note:

- 1.All reading above 1GHz is performed with peak and/or average measurements as necessary.
2. “ * ”, means this data is the worst value.
- 3.Emission Level = Reading Level + Correct Factor.
- 4.The average measurement was not performed when the peak measured data under the limit of average detection.
- 5.The emission above 13GHz were not included is because their levels are lower than 20dB form limit.

Model No	VE2A01	Site	CB4-H
Test Voltage	AC 120V/60Hz	Test Date	2020/5/8
Test Mode	Mode 1: Transmit_CDD	Engineer	Lion
Polarity	Vertical	Temperature (°C)	24.0
Test Condition	802.11b_Ch 11_2.462G	Humidity (%RH)	56.0

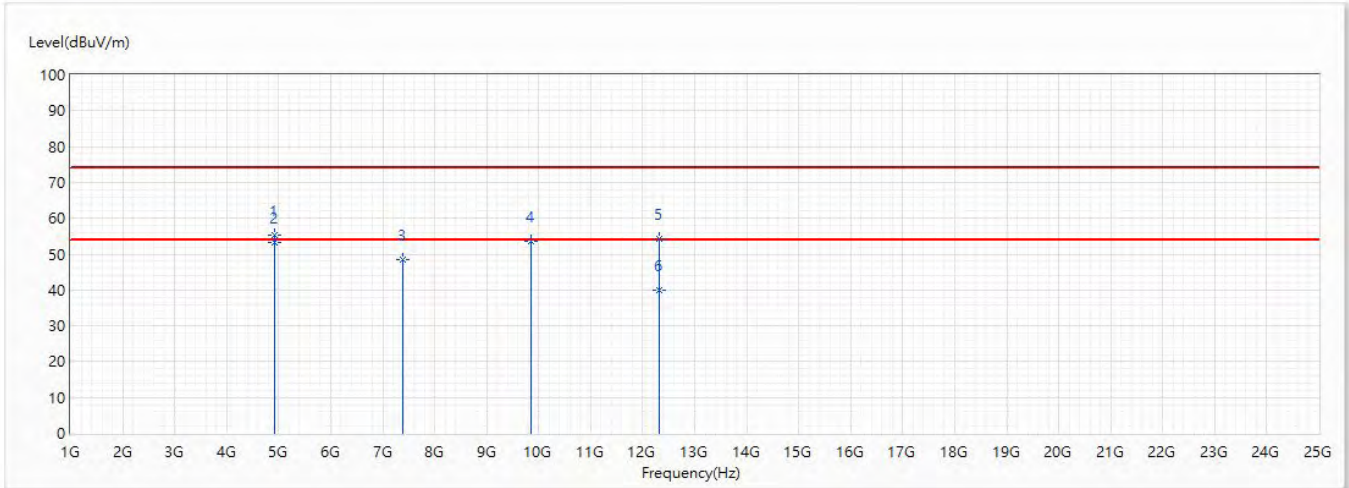

No	Frequency (MHz)	Emission Level (dBuV/m)	Limit (dBuV/m)	Margin (dB)	Reading Level (dBuV)	Correct Factor (dB/m)	Detector Type
1	4924	55.27	74.00	-18.73	56.40	-1.13	PK
* 2	4924	53.39	54.00	-0.61	54.52	-1.13	AV
3	7386	48.63	74.00	-25.37	41.97	6.66	PK
4	9848	53.50	74.00	-20.50	41.95	11.55	PK
5	12310	54.14	74.00	-19.86	41.09	13.05	PK
6	12310	40.06	54.00	-13.94	27.01	13.05	AV

Note:

- 1.All reading above 1GHz is performed with peak and/or average measurements as necessary.
2. “ * ”, means this data is the worst value.
- 3.Emission Level = Reading Level + Correct Factor.
- 4.The average measurement was not performed when the peak measured data under the limit of average detection.
- 5.The emission above 13GHz were not included is because their levels are lower than 20dB form limit.

Model No	VE2A01	Site	CB4-H
Test Voltage	AC 120V/60Hz	Test Date	2020/5/8
Test Mode	Mode 1: Transmit_CDD	Engineer	Lion
Polarity	Horizontal	Temperature (°C)	24.0
Test Condition	802.11g_Ch 1_2.412G	Humidity (%RH)	56.0

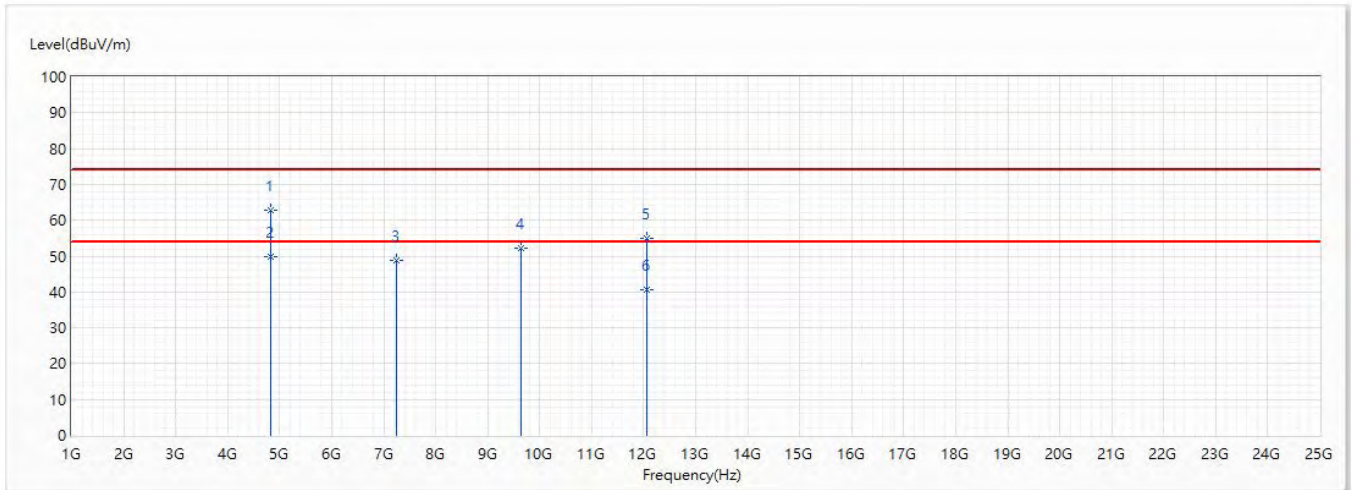

No	Frequency (MHz)	Emission Level (dBuV/m)	Limit (dBuV/m)	Margin (dB)	Reading Level (dBuV)	Correct Factor (dB/m)	Detector Type
1	4824	62.72	74.00	-11.28	64.25	-1.53	PK
* 2	4824	49.83	54.00	-4.17	51.36	-1.53	AV
3	7236	48.82	74.00	-25.18	42.65	6.17	PK
4	9648	52.18	74.00	-21.82	40.81	11.37	PK
5	12060	55.00	74.00	-19.00	41.51	13.49	PK
6	12060	40.57	54.00	-13.43	27.08	13.49	AV

Note:

- 1.All reading above 1GHz is performed with peak and/or average measurements as necessary.
2. “ * ”, means this data is the worst value.
- 3.Emission Level = Reading Level + Correct Factor.
- 4.The average measurement was not performed when the peak measured data under the limit of average detection.
- 5.The emission above 13GHz were not included is because their levels are lower than 20dB form limit.

Model No	VE2A01	Site	CB4-H
Test Voltage	AC 120V/60Hz	Test Date	2020/5/8
Test Mode	Mode 1: Transmit_CDD	Engineer	Lion
Polarity	Vertical	Temperature (°C)	24.0
Test Condition	802.11g_Ch 1_2.412G	Humidity (%RH)	56.0

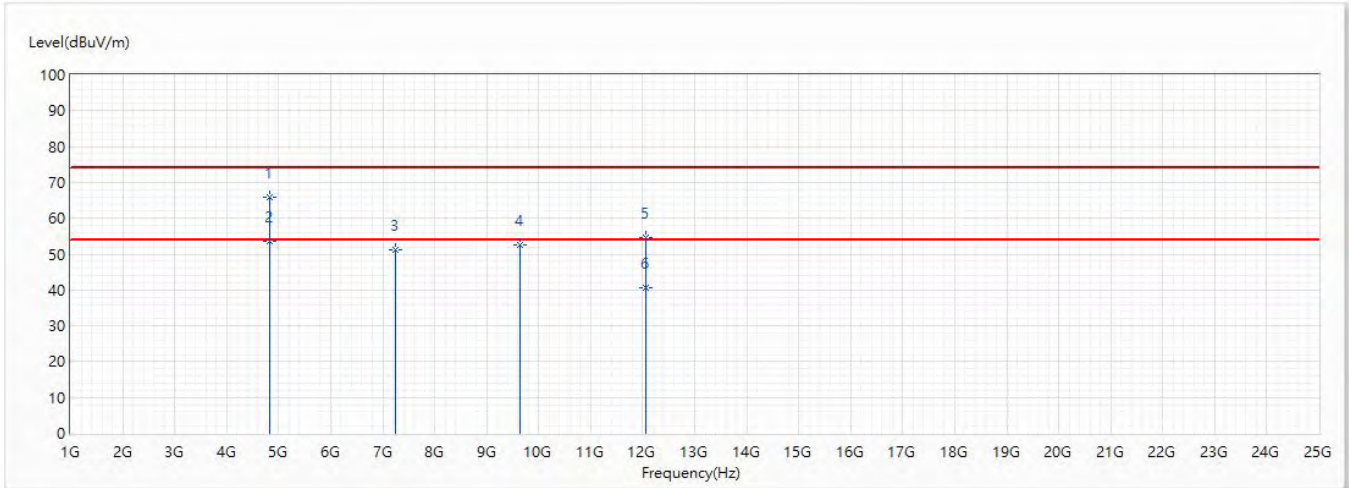

No	Frequency (MHz)	Emission Level (dBuV/m)	Limit (dBuV/m)	Margin (dB)	Reading Level (dBuV)	Correct Factor (dB/m)	Detector Type
1	4824	66.03	74.00	-7.97	67.56	-1.53	PK
* 2	4824	53.48	54.00	-0.52	55.01	-1.53	AV
3	7236	51.32	74.00	-22.68	45.15	6.17	PK
4	9648	52.58	74.00	-21.42	41.21	11.37	PK
5	12060	54.54	74.00	-19.46	41.05	13.49	PK
6	12060	40.60	54.00	-13.40	27.11	13.49	AV

Note:

- 1.All reading above 1GHz is performed with peak and/or average measurements as necessary.
2. “ * ”, means this data is the worst value.
- 3.Emission Level = Reading Level + Correct Factor.
- 4.The average measurement was not performed when the peak measured data under the limit of average detection.
- 5.The emission above 13GHz were not included is because their levels are lower than 20dB form limit.

Model No	VE2A01	Site	CB4-H
Test Voltage	AC 120V/60Hz	Test Date	2020/5/8
Test Mode	Mode 1: Transmit_CDD	Engineer	Lion
Polarity	Horizontal	Temperature (°C)	24.0
Test Condition	802.11g_Ch 6_2.437G	Humidity (%RH)	56.0

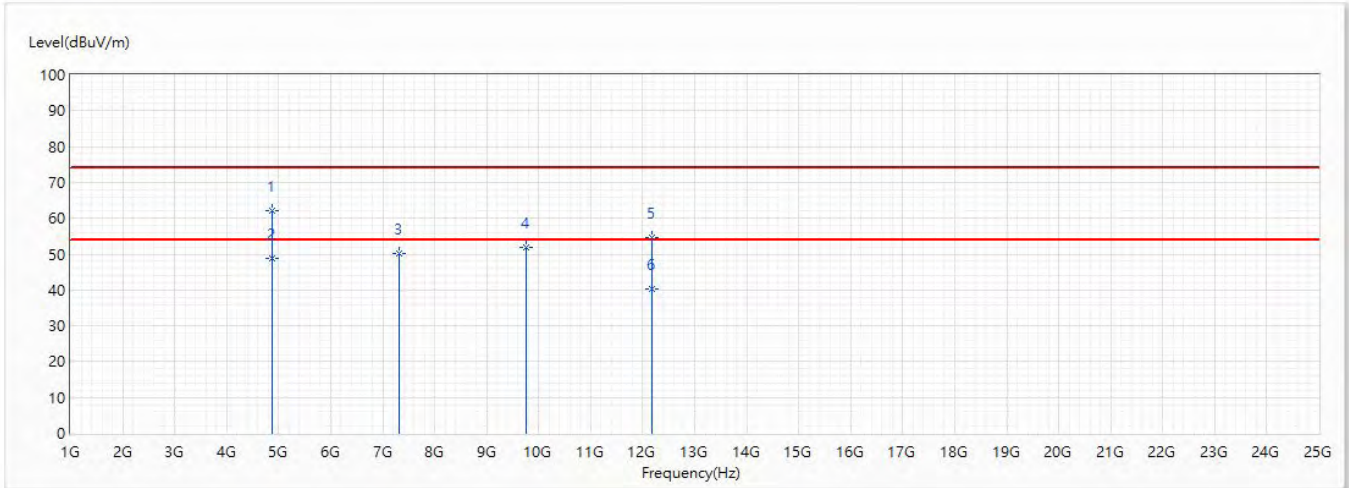

No	Frequency (MHz)	Emission Level (dBuV/m)	Limit (dBuV/m)	Margin (dB)	Reading Level (dBuV)	Correct Factor (dB/m)	Detector Type
1	4874	62.27	74.00	-11.73	63.60	-1.33	PK
* 2	4874	48.77	54.00	-5.23	50.10	-1.33	AV
3	7311	50.07	74.00	-23.93	43.65	6.42	PK
4	9748	51.74	74.00	-22.26	40.25	11.49	PK
5	12185	54.46	74.00	-19.54	41.18	13.28	PK
6	12185	40.34	54.00	-13.66	27.06	13.28	AV

Note:

- 1.All reading above 1GHz is performed with peak and/or average measurements as necessary.
2. “ * ”, means this data is the worst value.
- 3.Emission Level = Reading Level + Correct Factor.
- 4.The average measurement was not performed when the peak measured data under the limit of average detection.
- 5.The emission above 13GHz were not included is because their levels are lower than 20dB form limit.

Model No	VE2A01	Site	CB4-H
Test Voltage	AC 120V/60Hz	Test Date	2020/5/8
Test Mode	Mode 1: Transmit_CDD	Engineer	Lion
Polarity	Vertical	Temperature (°C)	24.0
Test Condition	802.11g_Ch 6_2.437G	Humidity (%RH)	56.0

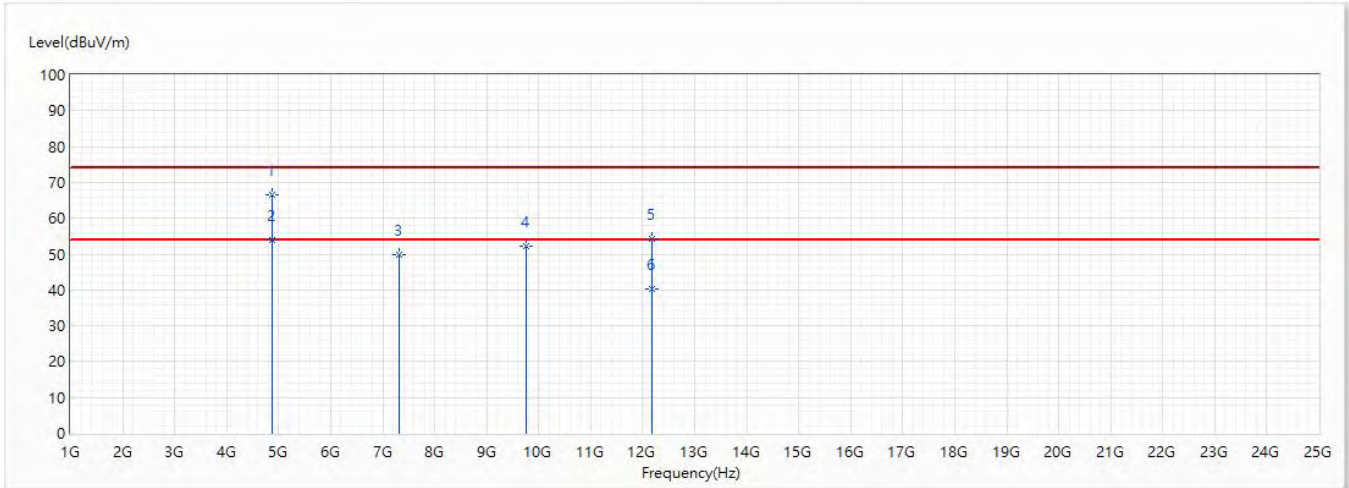

No	Frequency (MHz)	Emission Level (dBuV/m)	Limit (dBuV/m)	Margin (dB)	Reading Level (dBuV)	Correct Factor (dB/m)	Detector Type
1	4874	66.64	74.00	-7.36	67.97	-1.33	PK
* 2	4874	53.89	54.00	-0.11	55.22	-1.33	AV
3	7311	49.93	74.00	-24.07	43.51	6.42	PK
4	9748	52.11	74.00	-21.89	40.62	11.49	PK
5	12185	54.11	74.00	-19.89	40.83	13.28	PK
6	12185	40.42	54.00	-13.58	27.14	13.28	AV

Note:

- 1.All reading above 1GHz is performed with peak and/or average measurements as necessary.
2. “ * ”, means this data is the worst value.
- 3.Emission Level = Reading Level + Correct Factor.
- 4.The average measurement was not performed when the peak measured data under the limit of average detection.
- 5.The emission above 13GHz were not included is because their levels are lower than 20dB form limit.

Model No	VE2A01	Site	CB4-H
Test Voltage	AC 120V/60Hz	Test Date	2020/5/8
Test Mode	Mode 1: Transmit_CDD	Engineer	Lion
Polarity	Horizontal	Temperature (°C)	24.0
Test Condition	802.11g_Ch 11_2.462G	Humidity (%RH)	56.0

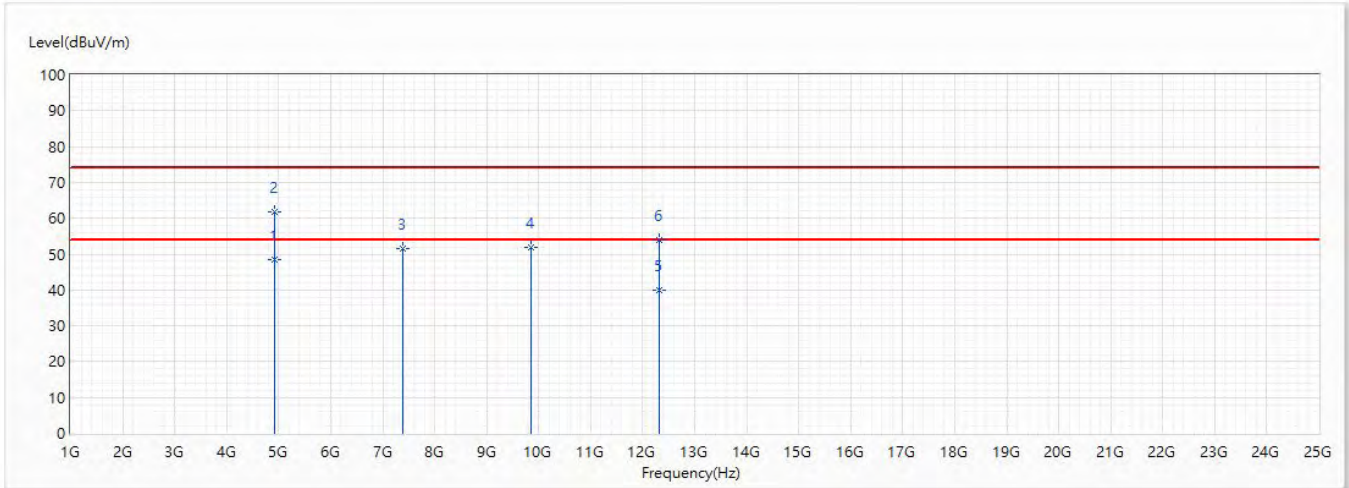

No	Frequency (MHz)	Emission Level (dBuV/m)	Limit (dBuV/m)	Margin (dB)	Reading Level (dBuV)	Correct Factor (dB/m)	Detector Type
* 1	4924	48.62	54.00	-5.38	49.75	-1.13	AV
2	4924	61.73	74.00	-12.27	62.86	-1.13	PK
3	7386	51.59	74.00	-22.41	44.93	6.66	PK
4	9848	51.88	74.00	-22.12	40.33	11.55	PK
5	12310	40.01	54.00	-13.99	26.96	13.05	AV
6	12310	54.01	74.00	-19.99	40.96	13.05	PK

Note:

- 1.All reading above 1GHz is performed with peak and/or average measurements as necessary.
2. “ * ”, means this data is the worst value.
- 3.Emission Level = Reading Level + Correct Factor.
- 4.The average measurement was not performed when the peak measured data under the limit of average detection.
- 5.The emission above 13GHz were not included is because their levels are lower than 20dB form limit.

Model No	VE2A01	Site	CB4-H
Test Voltage	AC 120V/60Hz	Test Date	2020/5/8
Test Mode	Mode 1: Transmit_CDD	Engineer	Lion
Polarity	Vertical	Temperature (°C)	24.0
Test Condition	802.11g_Ch 11_2.462G	Humidity (%RH)	56.0

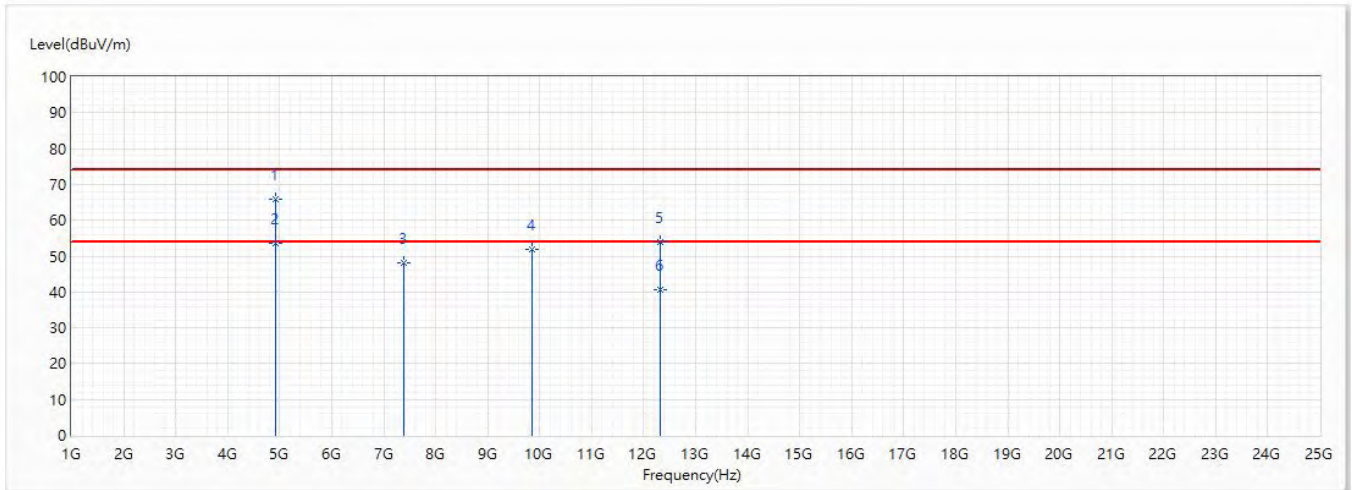

No	Frequency (MHz)	Emission Level (dBuV/m)	Limit (dBuV/m)	Margin (dB)	Reading Level (dBuV)	Correct Factor (dB/m)	Detector Type
1	4924	65.91	74.00	-8.09	67.04	-1.13	PK
* 2	4924	53.46	54.00	-0.54	54.59	-1.13	AV
3	7386	48.29	74.00	-25.71	41.63	6.66	PK
4	9848	51.87	74.00	-22.13	40.32	11.55	PK
5	12310	54.03	74.00	-19.97	40.98	13.05	PK
6	12310	40.47	54.00	-13.53	27.42	13.05	AV

Note:

- 1.All reading above 1GHz is performed with peak and/or average measurements as necessary.
2. “ * ”, means this data is the worst value.
- 3.Emission Level = Reading Level + Correct Factor.
- 4.The average measurement was not performed when the peak measured data under the limit of average detection.
- 5.The emission above 13GHz were not included is because their levels are lower than 20dB form limit.

Model No	VE2A01	Site	CB4-H
Test Voltage	AC 120V/60Hz	Test Date	2020/5/8
Test Mode	Mode 1: Transmit_CDD	Engineer	Lion
Polarity	Horizontal	Temperature (°C)	24.0
Test Condition	802.11n_20M_Ch 1_2.412G	Humidity (%RH)	56.0

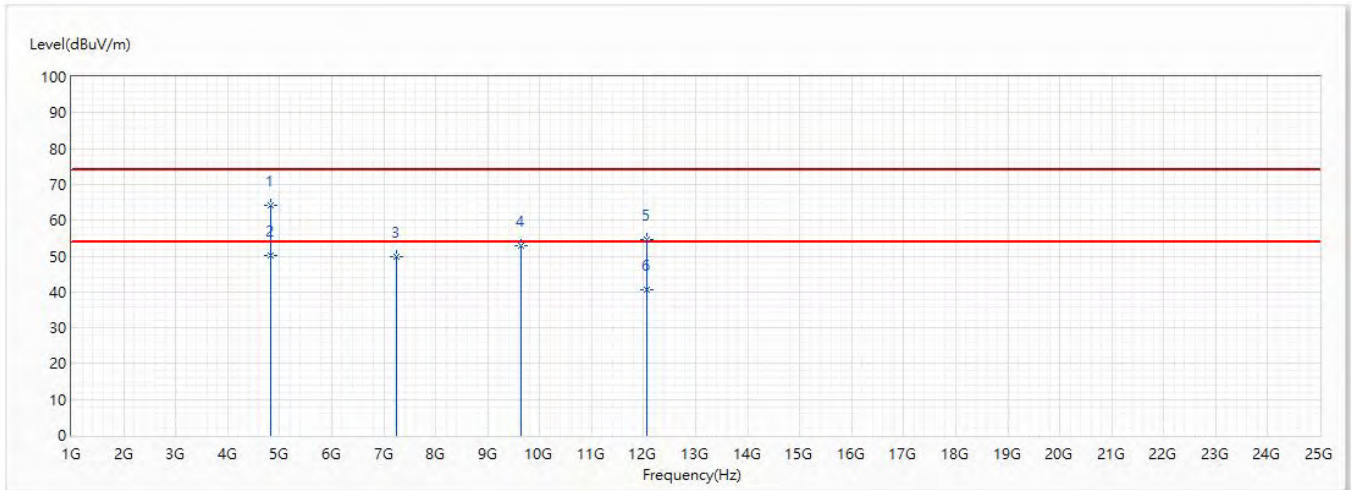

No	Frequency (MHz)	Emission Level (dBuV/m)	Limit (dBuV/m)	Margin (dB)	Reading Level (dBuV)	Correct Factor (dB/m)	Detector Type
1	4824	64.31	74.00	-9.69	65.84	-1.53	PK
* 2	4824	50.07	54.00	-3.93	51.60	-1.53	AV
3	7236	49.94	74.00	-24.06	43.77	6.17	PK
4	9648	52.96	74.00	-21.04	41.59	11.37	PK
5	12060	54.73	74.00	-19.27	41.24	13.49	PK
6	12060	40.70	54.00	-13.30	27.21	13.49	AV

Note:

- 1.All reading above 1GHz is performed with peak and/or average measurements as necessary.
2. “ * ”, means this data is the worst value.
- 3.Emission Level = Reading Level + Correct Factor.
- 4.The average measurement was not performed when the peak measured data under the limit of average detection.
- 5.The emission above 13GHz were not included is because their levels are lower than 20dB form limit.

Model No	VE2A01	Site	CB4-H
Test Voltage	AC 120V/60Hz	Test Date	2020/5/8
Test Mode	Mode 1: Transmit_CDD	Engineer	Lion
Polarity	Vertical	Temperature (°C)	24.0
Test Condition	802.11n_20M_Ch 1_2.412G	Humidity (%RH)	56.0

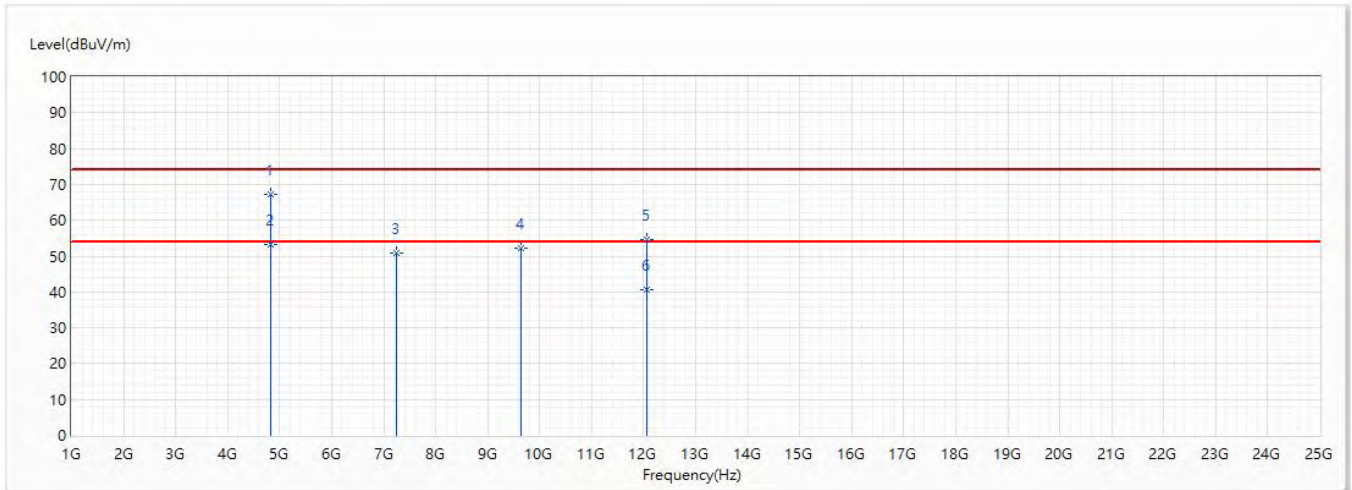

No	Frequency (MHz)	Emission Level (dBuV/m)	Limit (dBuV/m)	Margin (dB)	Reading Level (dBuV)	Correct Factor (dB/m)	Detector Type
1	4824	67.36	74.00	-6.64	68.89	-1.53	PK
* 2	4824	53.28	54.00	-0.72	54.81	-1.53	AV
3	7236	50.89	74.00	-23.11	44.72	6.17	PK
4	9648	52.20	74.00	-21.80	40.83	11.37	PK
5	12060	54.63	74.00	-19.37	41.14	13.49	PK
6	12060	40.69	54.00	-13.31	27.20	13.49	AV

Note:

- 1.All reading above 1GHz is performed with peak and/or average measurements as necessary.
2. “ * ”, means this data is the worst value.
- 3.Emission Level = Reading Level + Correct Factor.
- 4.The average measurement was not performed when the peak measured data under the limit of average detection.
- 5.The emission above 13GHz were not included is because their levels are lower than 20dB form limit.

Model No	VE2A01	Site	CB4-H
Test Voltage	AC 120V/60Hz	Test Date	2020/5/8
Test Mode	Mode 1: Transmit_CDD	Engineer	Lion
Polarity	Horizontal	Temperature (°C)	24.0
Test Condition	802.11n_20M_Ch 6_2.437G	Humidity (%RH)	56.0

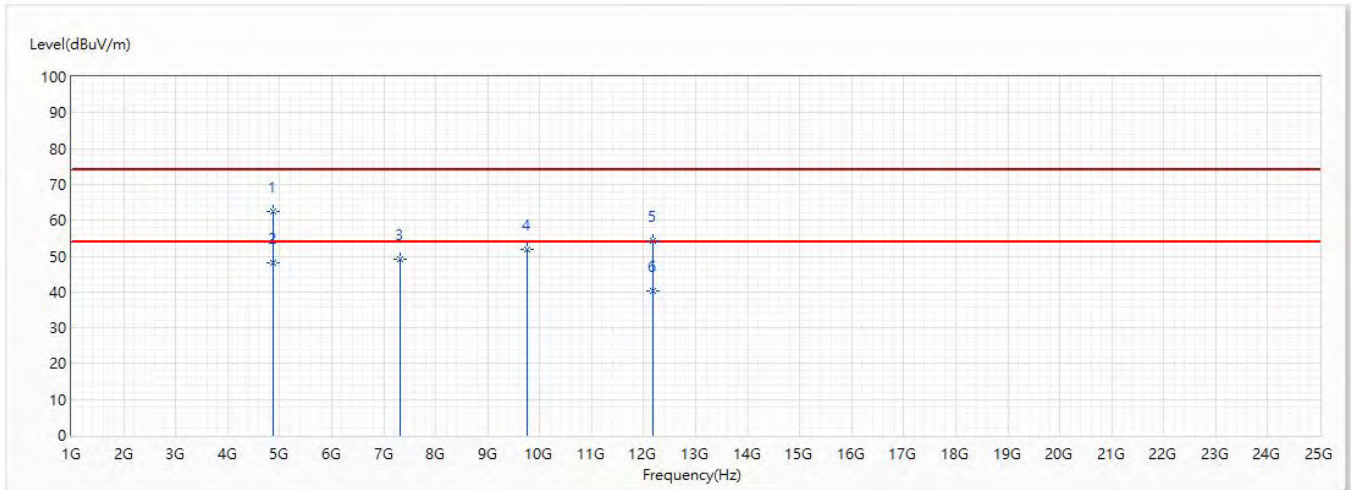

No	Frequency (MHz)	Emission Level (dBuV/m)	Limit (dBuV/m)	Margin (dB)	Reading Level (dBuV)	Correct Factor (dB/m)	Detector Type
1	4874	62.35	74.00	-11.65	63.68	-1.33	PK
* 2	4874	48.27	54.00	-5.73	49.60	-1.33	AV
3	7311	49.20	74.00	-24.80	42.78	6.42	PK
4	9748	51.90	74.00	-22.10	40.41	11.49	PK
5	12185	54.39	74.00	-19.61	41.11	13.28	PK
6	12185	40.27	54.00	-13.73	26.99	13.28	AV

Note:

- 1.All reading above 1GHz is performed with peak and/or average measurements as necessary.
2. “ * ”, means this data is the worst value.
- 3.Emission Level = Reading Level + Correct Factor.
- 4.The average measurement was not performed when the peak measured data under the limit of average detection.
- 5.The emission above 13GHz were not included is because their levels are lower than 20dB form limit.

Model No	VE2A01	Site	CB4-H
Test Voltage	AC 120V/60Hz	Test Date	2020/5/8
Test Mode	Mode 1: Transmit_CDD	Engineer	Lion
Polarity	Vertical	Temperature (°C)	24.0
Test Condition	802.11n_20M_Ch 6_2.437G	Humidity (%RH)	56.0

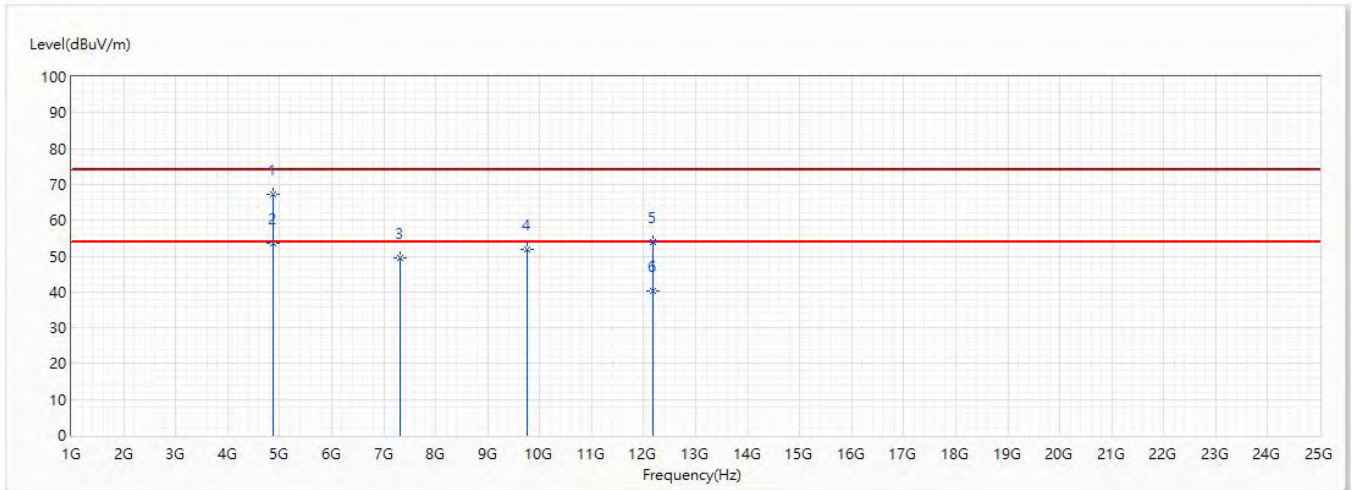

No	Frequency (MHz)	Emission Level (dBuV/m)	Limit (dBuV/m)	Margin (dB)	Reading Level (dBuV)	Correct Factor (dB/m)	Detector Type
1	4874	67.25	74.00	-6.75	68.58	-1.33	PK
* 2	4874	53.51	54.00	-0.49	54.84	-1.33	AV
3	7311	49.57	74.00	-24.43	43.15	6.42	PK
4	9748	51.97	74.00	-22.03	40.48	11.49	PK
5	12185	54.06	74.00	-19.94	40.78	13.28	PK
6	12185	40.32	54.00	-13.68	27.04	13.28	AV

Note:

- 1.All reading above 1GHz is performed with peak and/or average measurements as necessary.
2. “ * ”, means this data is the worst value.
- 3.Emission Level = Reading Level + Correct Factor.
- 4.The average measurement was not performed when the peak measured data under the limit of average detection.
- 5.The emission above 13GHz were not included is because their levels are lower than 20dB form limit.

Model No	VE2A01	Site	CB4-H
Test Voltage	AC 120V/60Hz	Test Date	2020/5/8
Test Mode	Mode 1: Transmit_CDD	Engineer	Lion
Polarity	Horizontal	Temperature (°C)	24.0
Test Condition	802.11n_20M_Ch 11_2.462G	Humidity (%RH)	56.0

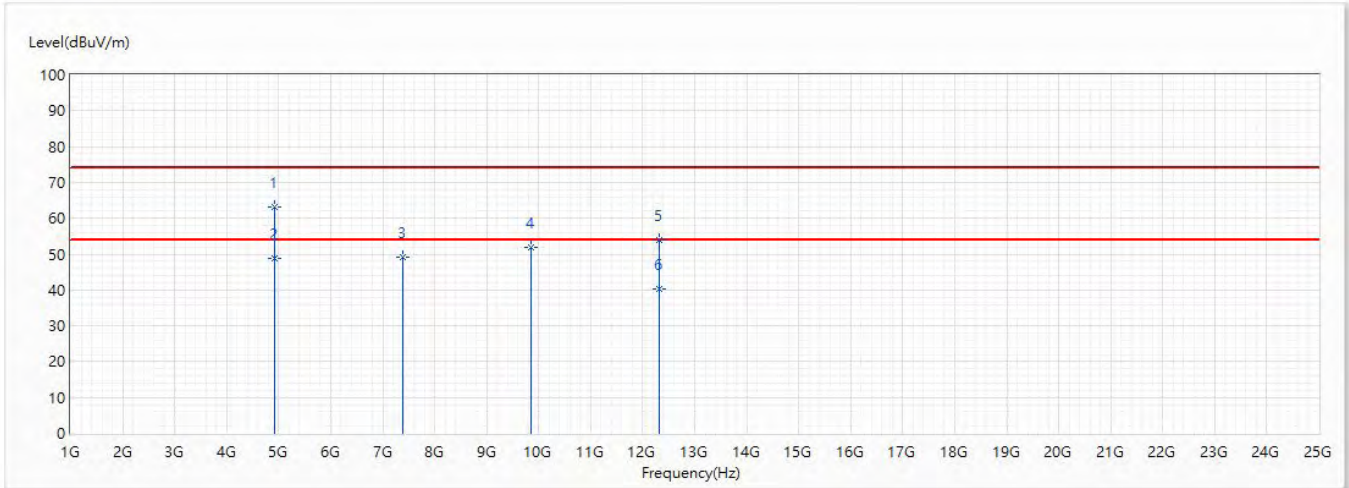

No	Frequency (MHz)	Emission Level (dBuV/m)	Limit (dBuV/m)	Margin (dB)	Reading Level (dBuV)	Correct Factor (dB/m)	Detector Type
1	4924	63.14	74.00	-10.86	64.27	-1.13	PK
* 2	4924	48.88	54.00	-5.12	50.01	-1.13	AV
3	7386	49.21	74.00	-24.79	42.55	6.66	PK
4	9848	52.02	74.00	-21.98	40.47	11.55	PK
5	12310	54.05	74.00	-19.95	41.00	13.05	PK
6	12310	40.20	54.00	-13.80	27.15	13.05	AV

Note:

- 1.All reading above 1GHz is performed with peak and/or average measurements as necessary.
2. “ * ”, means this data is the worst value.
- 3.Emission Level = Reading Level + Correct Factor.
- 4.The average measurement was not performed when the peak measured data under the limit of average detection.
- 5.The emission above 13GHz were not included is because their levels are lower than 20dB form limit.

Model No	VE2A01	Site	CB4-H
Test Voltage	AC 120V/60Hz	Test Date	2020/5/8
Test Mode	Mode 1: Transmit_CDD	Engineer	Lion
Polarity	Vertical	Temperature (°C)	24.0
Test Condition	802.11n_20M_Ch 11_2.462G	Humidity (%RH)	56.0

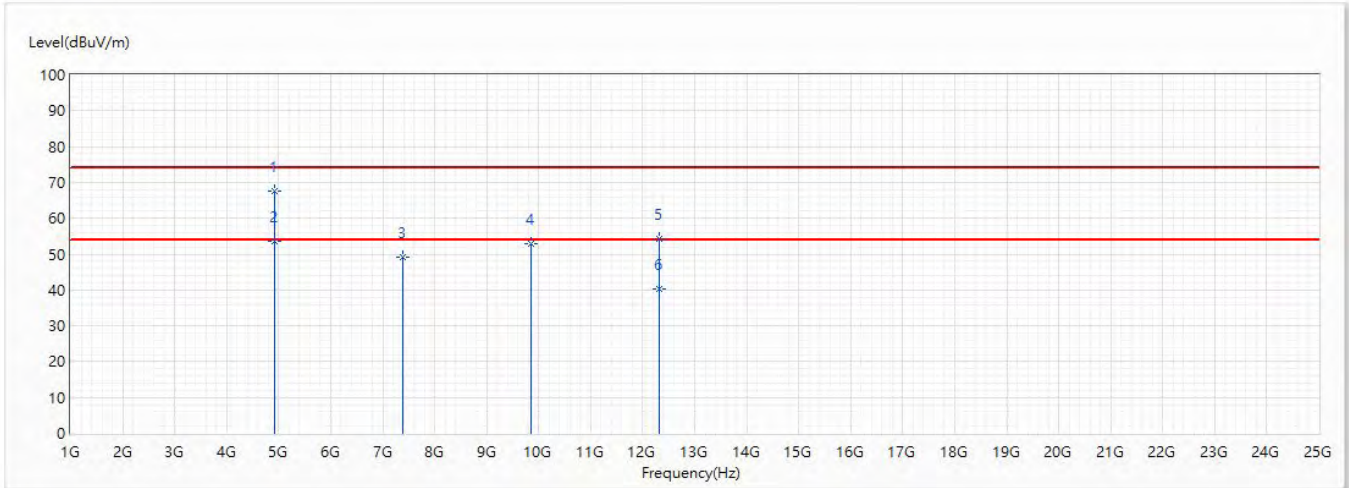

No	Frequency (MHz)	Emission Level (dBuV/m)	Limit (dBuV/m)	Margin (dB)	Reading Level (dBuV)	Correct Factor (dB/m)	Detector Type
1	4924	67.51	74.00	-6.49	68.64	-1.13	PK
* 2	4924	53.55	54.00	-0.45	54.68	-1.13	AV
3	7386	49.15	74.00	-24.85	42.49	6.66	PK
4	9848	52.82	74.00	-21.18	41.27	11.55	PK
5	12310	54.41	74.00	-19.59	41.36	13.05	PK
6	12310	40.36	54.00	-13.64	27.31	13.05	AV

Note:

- 1.All reading above 1GHz is performed with peak and/or average measurements as necessary.
2. “ * ”, means this data is the worst value.
- 3.Emission Level = Reading Level + Correct Factor.
- 4.The average measurement was not performed when the peak measured data under the limit of average detection.
- 5.The emission above 13GHz were not included is because their levels are lower than 20dB form limit.

Model No	VE2A01	Site	CB4-H
Test Voltage	AC 120V/60Hz	Test Date	2020/5/8
Test Mode	Mode 1: Transmit_CDD	Engineer	Lion
Polarity	Horizontal	Temperature (°C)	24.0
Test Condition	802.11n_40M_Ch 3_2.422G	Humidity (%RH)	56.0

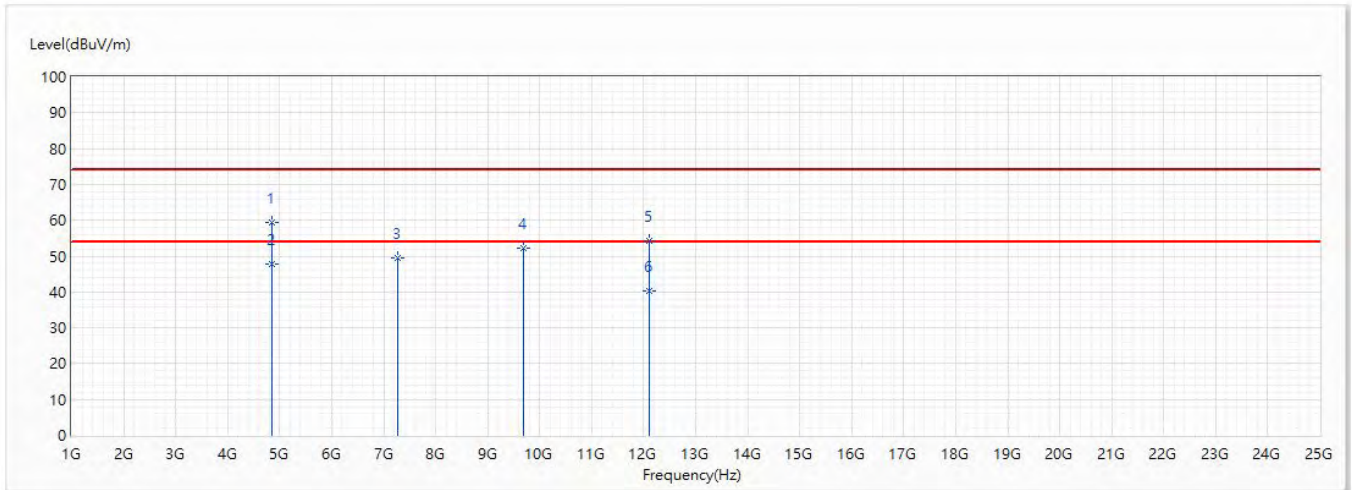

No	Frequency (MHz)	Emission Level (dBuV/m)	Limit (dBuV/m)	Margin (dB)	Reading Level (dBuV)	Correct Factor (dB/m)	Detector Type
1	4844	59.44	74.00	-14.56	60.88	-1.44	PK
* 2	4844	47.66	54.00	-6.34	49.10	-1.44	AV
3	7266	49.41	74.00	-24.59	43.14	6.27	PK
4	9688	52.22	74.00	-21.78	40.81	11.41	PK
5	12110	54.40	74.00	-19.60	40.99	13.41	PK
6	12110	40.41	54.00	-13.59	27.00	13.41	AV

Note:

- 1.All reading above 1GHz is performed with peak and/or average measurements as necessary.
2. “ * ”, means this data is the worst value.
- 3.Emission Level = Reading Level + Correct Factor.
- 4.The average measurement was not performed when the peak measured data under the limit of average detection.
- 5.The emission above 13GHz were not included is because their levels are lower than 20dB form limit.

Model No	VE2A01	Site	CB4-H
Test Voltage	AC 120V/60Hz	Test Date	2020/5/8
Test Mode	Mode 1: Transmit_CDD	Engineer	Lion
Polarity	Vertical	Temperature (°C)	24.0
Test Condition	802.11n_40M_Ch 3_2.422G	Humidity (%RH)	56.0

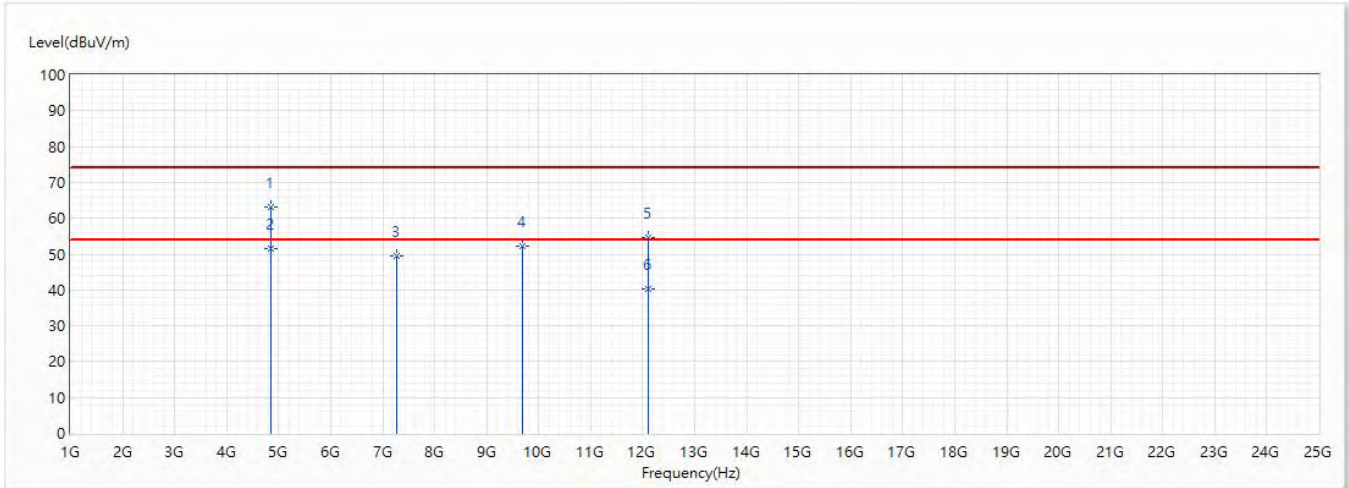

No	Frequency (MHz)	Emission Level (dBuV/m)	Limit (dBuV/m)	Margin (dB)	Reading Level (dBuV)	Correct Factor (dB/m)	Detector Type
1	4844	63.10	74.00	-10.90	64.54	-1.44	PK
* 2	4844	51.38	54.00	-2.62	52.82	-1.44	AV
3	7266	49.61	74.00	-24.39	43.34	6.27	PK
4	9688	52.05	74.00	-21.95	40.64	11.41	PK
5	12110	54.46	74.00	-19.54	41.05	13.41	PK
6	12110	40.43	54.00	-13.57	27.02	13.41	AV

Note:

- 1.All reading above 1GHz is performed with peak and/or average measurements as necessary.
2. “ * ”, means this data is the worst value.
- 3.Emission Level = Reading Level + Correct Factor.
- 4.The average measurement was not performed when the peak measured data under the limit of average detection.
- 5.The emission above 13GHz were not included is because their levels are lower than 20dB form limit.

Model No	VE2A01	Site	CB4-H
Test Voltage	AC 120V/60Hz	Test Date	2020/5/8
Test Mode	Mode 1: Transmit_CDD	Engineer	Lion
Polarity	Horizontal	Temperature (°C)	24.0
Test Condition	802.11n_40M_Ch 6_2.437G	Humidity (%RH)	56.0

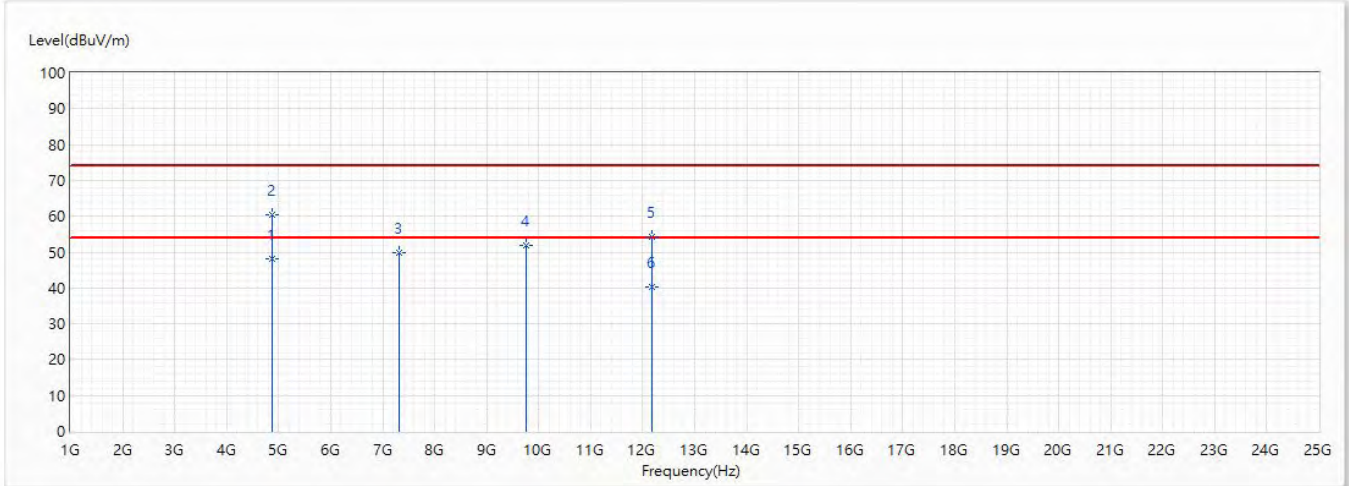

No	Frequency (MHz)	Emission Level (dBuV/m)	Limit (dBuV/m)	Margin (dB)	Reading Level (dBuV)	Correct Factor (dB/m)	Detector Type
1	4874	48.23	74.00	-25.77	49.56	-1.33	PK
* 2	4874	60.34	74.00	-13.66	61.67	-1.33	PK
3	7311	49.83	74.00	-24.17	43.41	6.42	PK
4	9748	52.00	74.00	-22.00	40.51	11.49	PK
5	12185	54.33	74.00	-19.67	41.05	13.28	PK
6	12185	40.33	54.00	-13.67	27.05	13.28	AV

Note:

- 1.All reading above 1GHz is performed with peak and/or average measurements as necessary.
2. “ * ”, means this data is the worst value.
- 3.Emission Level = Reading Level + Correct Factor.
- 4.The average measurement was not performed when the peak measured data under the limit of average detection.
- 5.The emission above 13GHz were not included is because their levels are lower than 20dB form limit.

Model No	VE2A01	Site	CB4-H
Test Voltage	AC 120V/60Hz	Test Date	2020/5/8
Test Mode	Mode 1: Transmit_CDD	Engineer	Lion
Polarity	Vertical	Temperature (°C)	24.0
Test Condition	802.11n_40M_Ch 6_2.437G	Humidity (%RH)	56.0

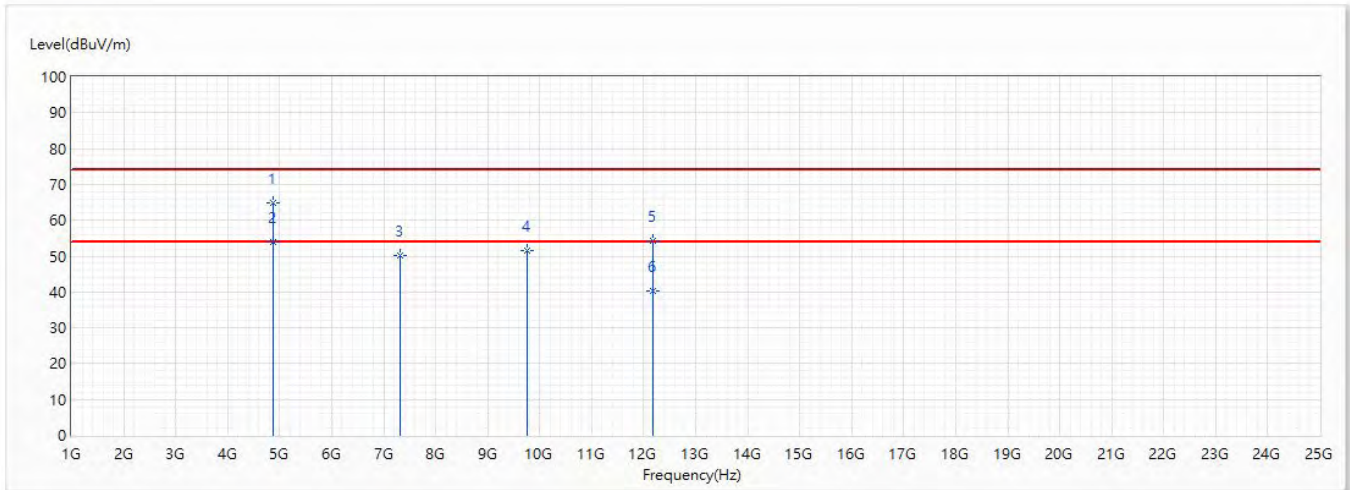

No	Frequency (MHz)	Emission Level (dBuV/m)	Limit (dBuV/m)	Margin (dB)	Reading Level (dBuV)	Correct Factor (dB/m)	Detector Type
1	4874	65.00	74.00	-9.00	66.33	-1.33	PK
* 2	4874	53.80	54.00	-0.20	55.13	-1.33	AV
3	7311	50.34	74.00	-23.66	43.92	6.42	PK
4	9748	51.65	74.00	-22.35	40.16	11.49	PK
5	12185	54.20	74.00	-19.80	40.92	13.28	PK
6	12185	40.33	54.00	-13.67	27.05	13.28	AV

Note:

- 1.All reading above 1GHz is performed with peak and/or average measurements as necessary.
2. “ * ”, means this data is the worst value.
- 3.Emission Level = Reading Level + Correct Factor.
- 4.The average measurement was not performed when the peak measured data under the limit of average detection.
- 5.The emission above 13GHz were not included is because their levels are lower than 20dB form limit.

Model No	VE2A01	Site	CB4-H
Test Voltage	AC 120V/60Hz	Test Date	2020/5/8
Test Mode	Mode 1: Transmit_CDD	Engineer	Lion
Polarity	Horizontal	Temperature (°C)	24.0
Test Condition	802.11n_40M_Ch 9_2.452G	Humidity (%RH)	56.0

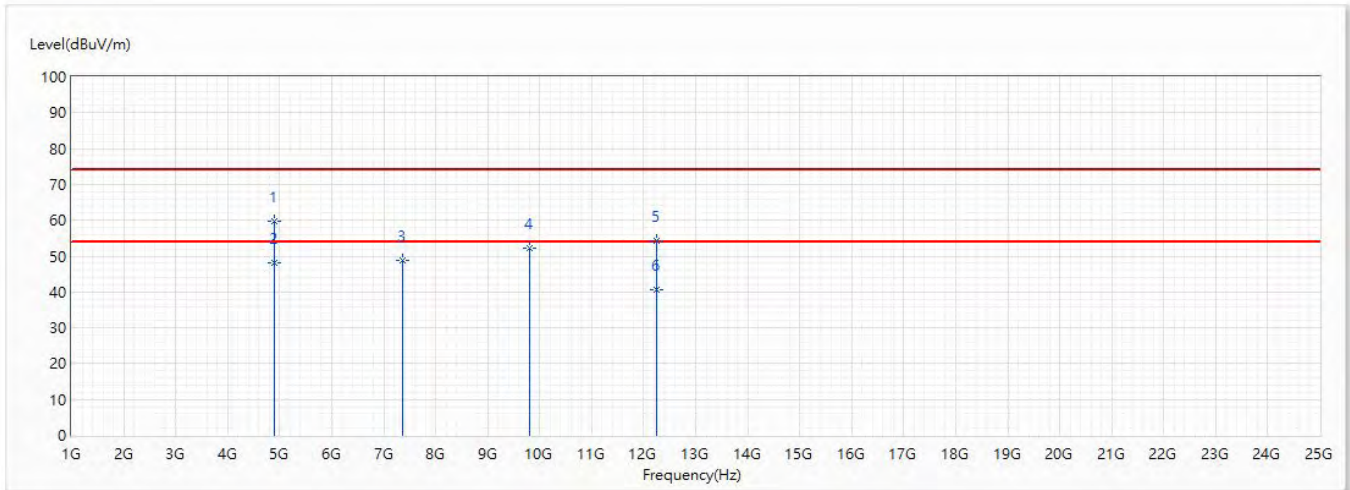

No	Frequency (MHz)	Emission Level (dBuV/m)	Limit (dBuV/m)	Margin (dB)	Reading Level (dBuV)	Correct Factor (dB/m)	Detector Type
1	4904	59.80	74.00	-14.20	61.01	-1.21	PK
* 2	4904	48.09	54.00	-5.91	49.30	-1.21	AV
3	7356	48.76	74.00	-25.24	42.20	6.56	PK
4	9808	52.38	74.00	-21.62	40.86	11.52	PK
5	12260	54.18	74.00	-19.82	41.03	13.15	PK
6	12260	40.47	54.00	-13.53	27.32	13.15	AV

Note:

- 1.All reading above 1GHz is performed with peak and/or average measurements as necessary.
2. “ * ”, means this data is the worst value.
- 3.Emission Level = Reading Level + Correct Factor.
- 4.The average measurement was not performed when the peak measured data under the limit of average detection.
- 5.The emission above 13GHz were not included is because their levels are lower than 20dB form limit.

Model No	VE2A01	Site	CB4-H
Test Voltage	AC 120V/60Hz	Test Date	2020/5/8
Test Mode	Mode 1: Transmit_CDD	Engineer	Lion
Polarity	Vertical	Temperature (°C)	24.0
Test Condition	802.11n_40M_Ch 9_2.452G	Humidity (%RH)	56.0

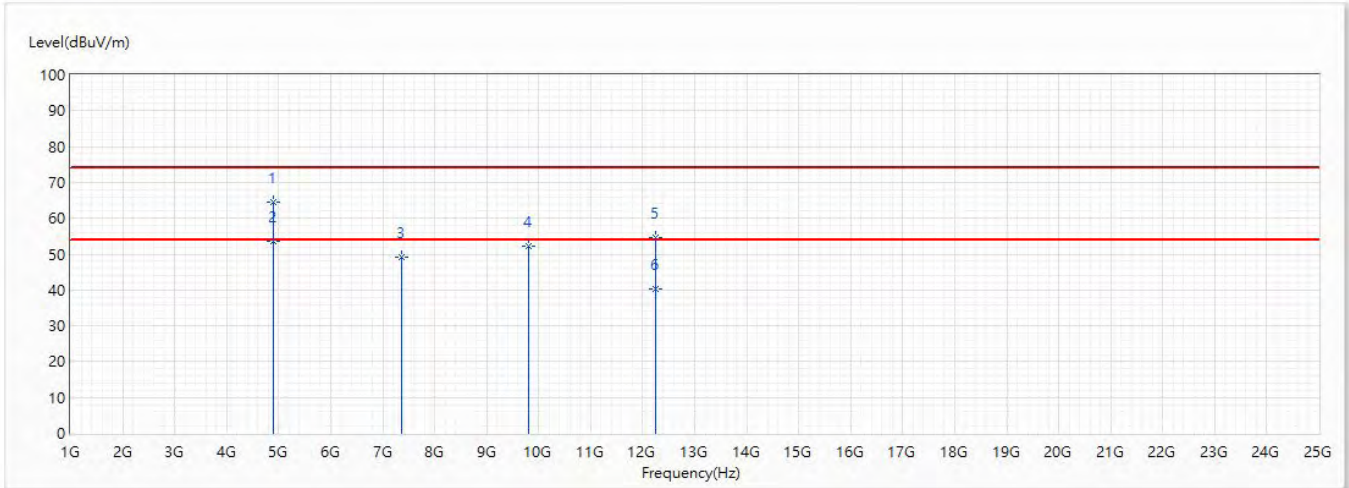

No	Frequency (MHz)	Emission Level (dBuV/m)	Limit (dBuV/m)	Margin (dB)	Reading Level (dBuV)	Correct Factor (dB/m)	Detector Type
1	4904	64.51	74.00	-9.49	65.72	-1.21	PK
* 2	4904	53.56	54.00	-0.44	54.77	-1.21	AV
3	7356	48.99	74.00	-25.01	42.43	6.56	PK
4	9808	52.30	74.00	-21.70	40.78	11.52	PK
5	12260	54.53	74.00	-19.47	41.38	13.15	PK
6	12260	40.39	54.00	-13.61	27.24	13.15	AV

Note:

- 1.All reading above 1GHz is performed with peak and/or average measurements as necessary.
2. “ * ”, means this data is the worst value.
- 3.Emission Level = Reading Level + Correct Factor.
- 4.The average measurement was not performed when the peak measured data under the limit of average detection.
- 5.The emission above 13GHz were not included is because their levels are lower than 20dB form limit.

6. RF antenna conducted test

6.1. Test Setup

RF Antenna Conducted Measurement:

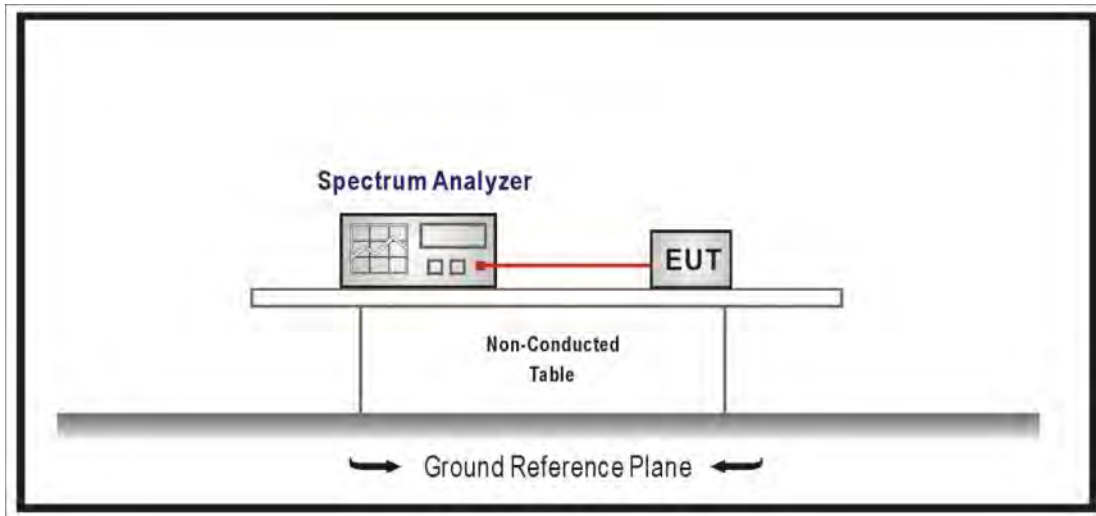

6.2. Limits

In any 100 kHz bandwidth outside the frequency band in which the spread spectrum intentional radiator is operating, the radio frequency power that is produced by the intentional radiator shall be at least 30 dB below that in the 100 kHz bandwidth within the band that contains the highest level of the desired power, based on an RF conducted or radiated measurement. Attenuation below the general limits specified in Section 15.209(a) is not required. In addition, radiated emissions which fall in the restricted bands, as defined in Section 15.205(a), must also comply with the radiated emission limits specified in Section 15.209(a) (see Section 15.205(c)).

6.3. Test Procedure

The EUT was setup according to ANSI C63.10: 2013 and tested according to DTS test procedure of KDB 558074 D01 V05r02 for compliance to FCC 47CFR 15.247 requirements. Set RBW = 100 kHz, Set VBW > RBW, scan up through 10th harmonic.

6.4. Test Specification

According to FCC Part 15 Subpart C Paragraph 15.247: 2019

6.5. Test Result

Product	Venation E2 IoT Gateway		
Test Item	RF antenna conducted test		
Test Mode	Mode 1: Transmit_CDD		
Date of Test	2020/05/12	Test Site	SR12-H
Temperature(°C)	23	Humidity (%RH)	60

IEEE 802.11b (ANT 0)				
Channel	Frequency (MHz)	Measure Level (dBc)	Limit (dBc)	Result
1	2412	41.350	≥30	Pass
6	2437	44.010	≥30	Pass
11	2462	43.180	≥30	Pass

Channel 1 (2412MHz)

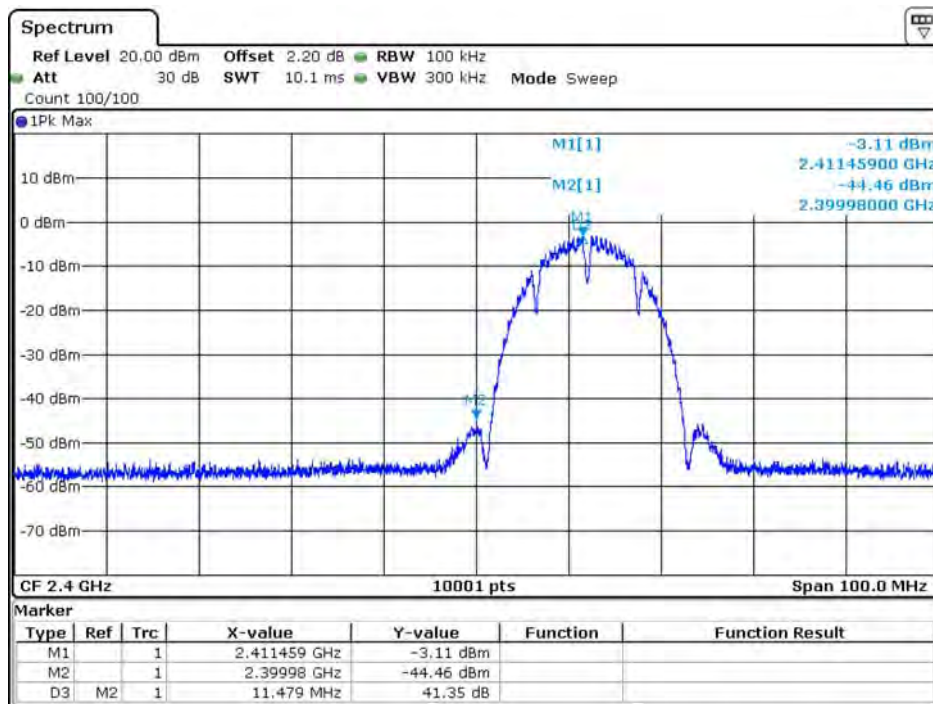

Date: 12 MAY 2020 17:41:37

Channel 6 (2437MHz)

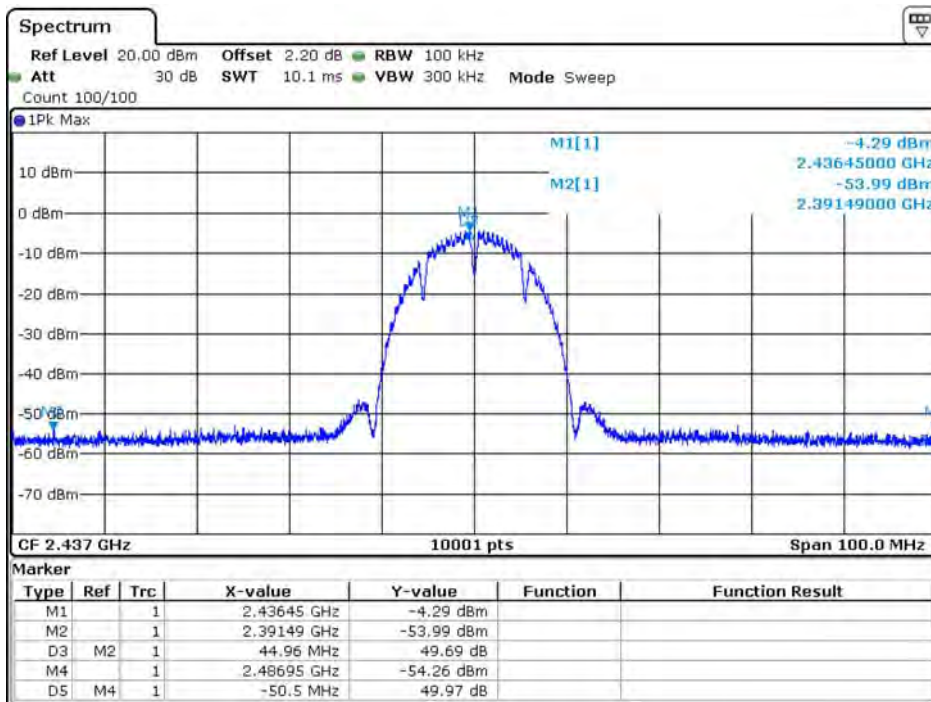

Date: 12 MAY 2020 17:44:04

Channel 11 (2462MHz)

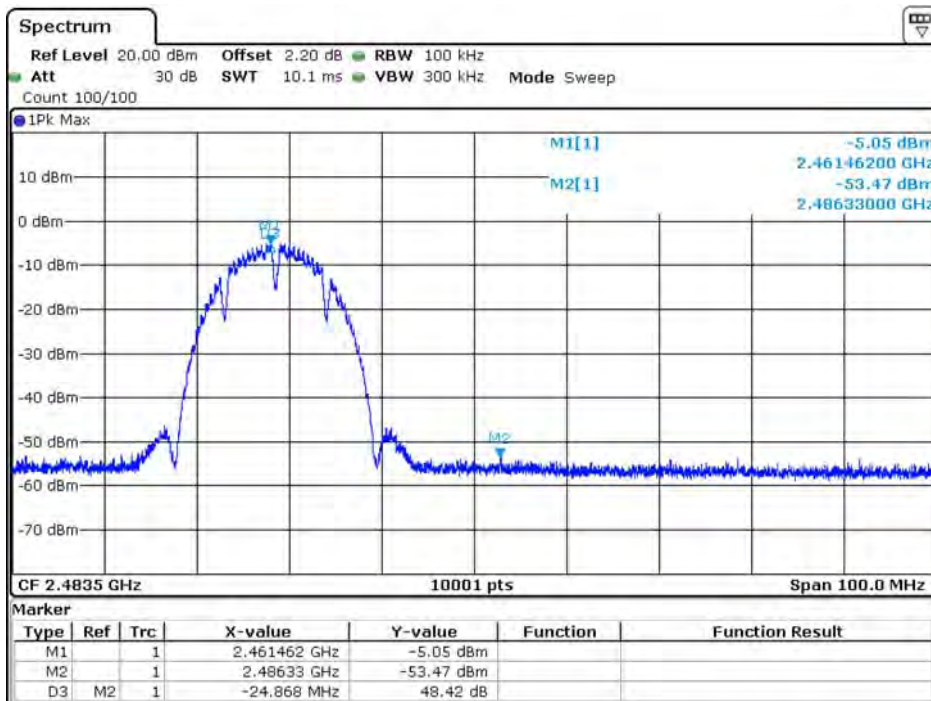

Date: 12 MAY 2020 17:44:48

Product	Venation E2 IoT Gateway		
Test Item	RF antenna conducted test		
Test Mode	Mode 1: Transmit_CDD		
Date of Test	2020/05/12	Test Site	SR12-H
Temperature(°C)	23	Humidity (%RH)	60

IEEE 802.11b (ANT 1)				
Channel	Frequency (MHz)	Measure Level (dBc)	Limit (dBc)	Result
1	2412	42.400	≥30	Pass
6	2437	45.830	≥30	Pass
11	2462	43.980	≥30	Pass

Channel 1 (2412MHz)

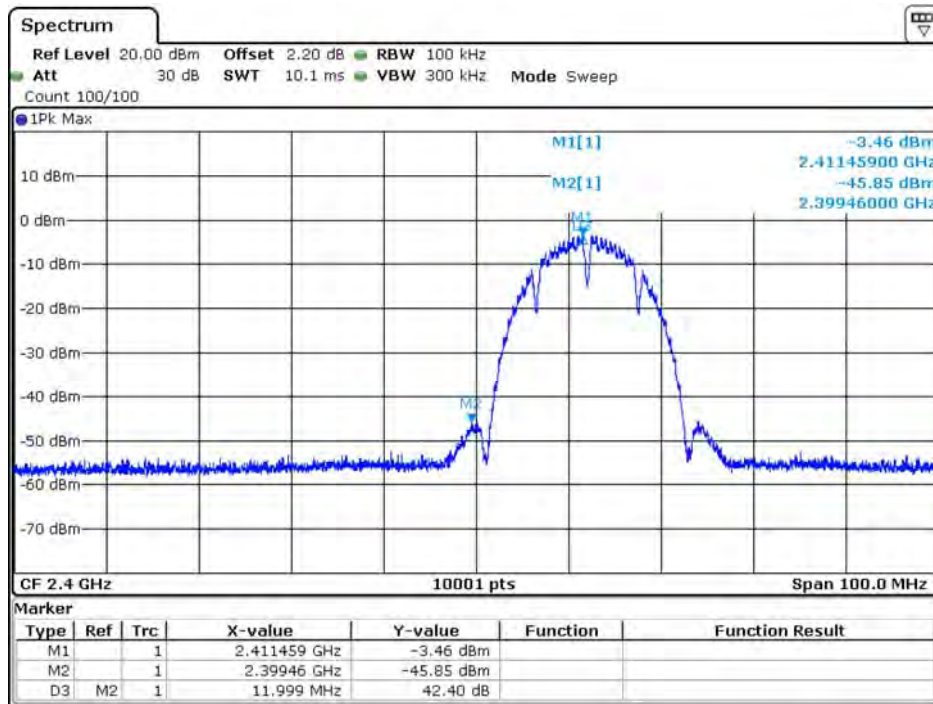

Date: 12 MAY 2020 17:42:37

Channel 6 (2437MHz)

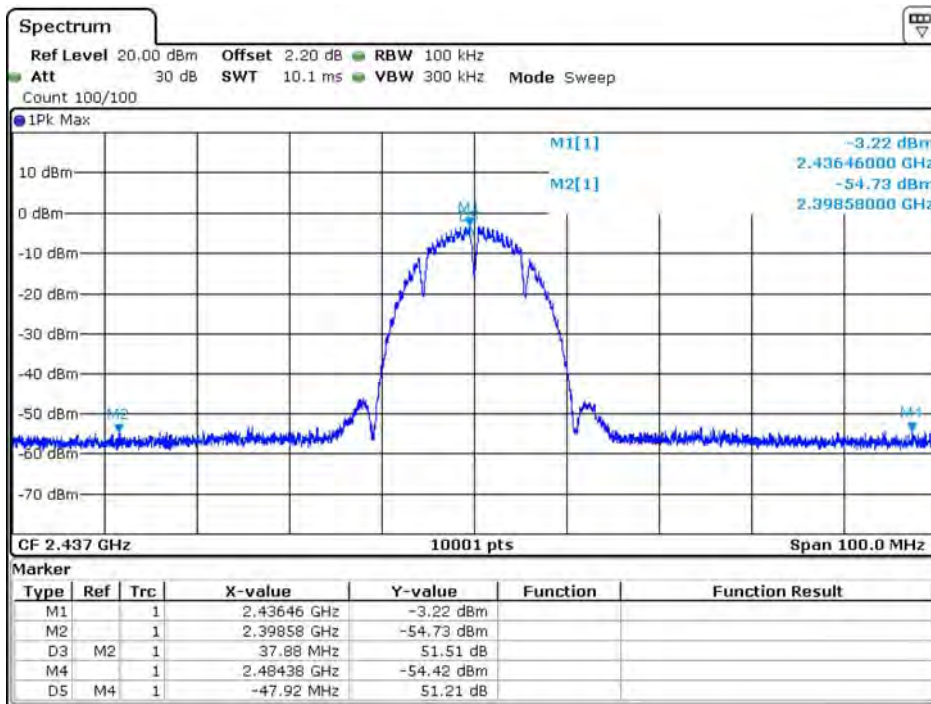

Date: 12 MAY 2020 17:43:34

Channel 11 (2462MHz)

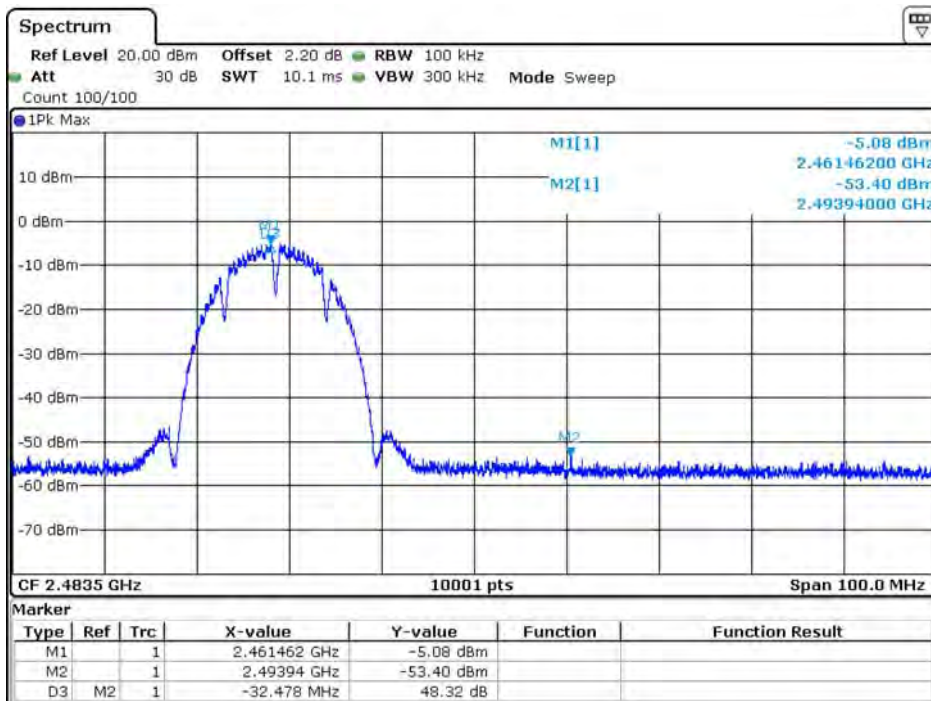

Date: 12 MAY 2020 17:45:18

Product	Venation E2 IoT Gateway		
Test Item	RF antenna conducted test		
Test Mode	Mode 1: Transmit_CDD		
Date of Test	2020/05/12	Test Site	SR12-H
Temperature(°C)	23	Humidity (%RH)	60

IEEE 802.11g (ANT 0)				
Channel	Frequency (MHz)	Measure Level (dBc)	Limit (dBc)	Result
1	2412	35.730	≥30	Pass
6	2437	48.080	≥30	Pass
11	2462	47.430	≥30	Pass

Channel 1 (2412MHz)

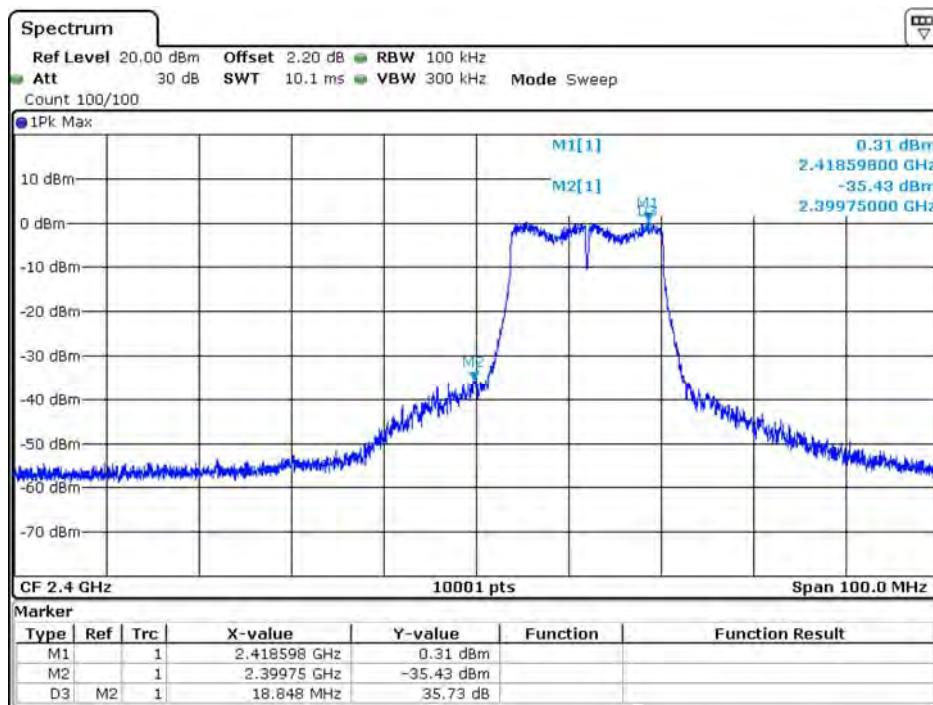

Date: 12 MAY 2020 17:39:51

Channel 6 (2437MHz)

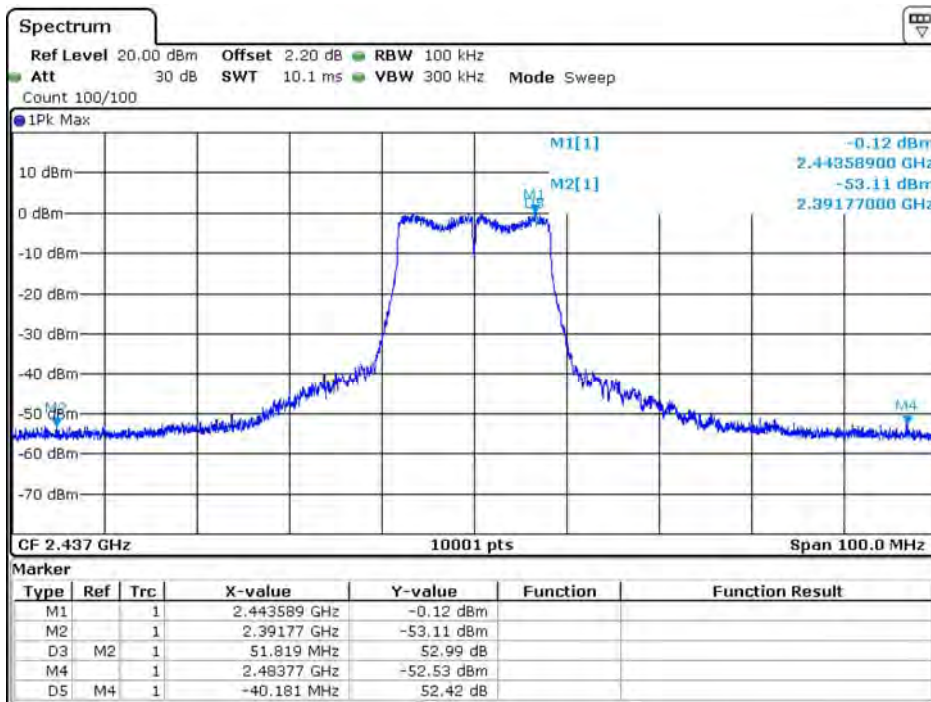

Date: 12 MAY 2020 17:36:18

Channel 11 (2462MHz)

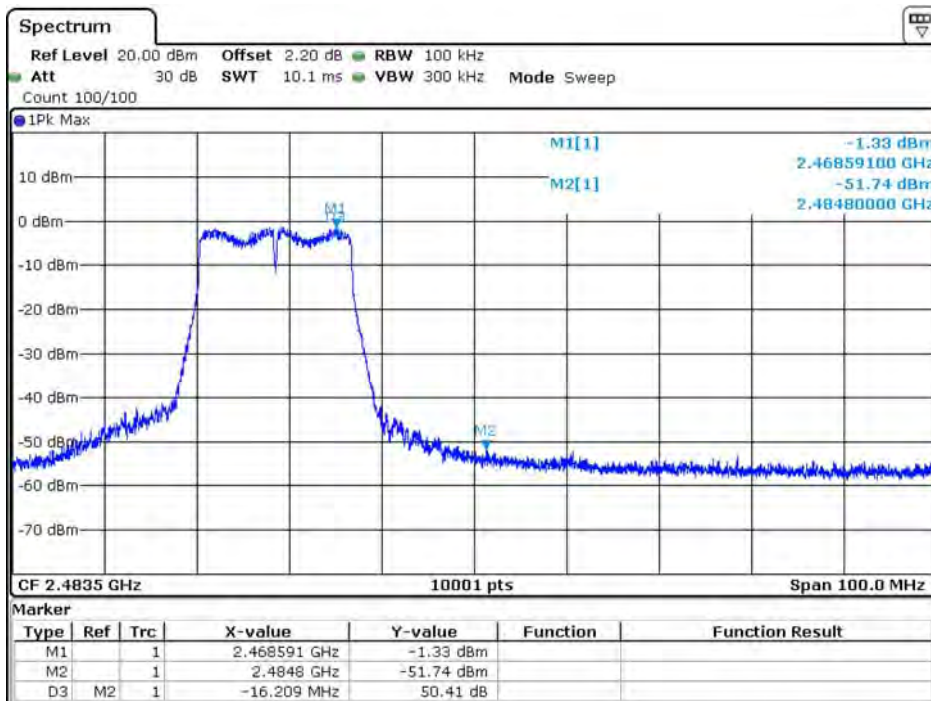

Date: 12 MAY 2020 17:34:18

Product	Venation E2 IoT Gateway		
Test Item	RF antenna conducted test		
Test Mode	Mode 1: Transmit_CDD		
Date of Test	2020/05/12	Test Site	SR12-H
Temperature(°C)	23	Humidity (%RH)	60

IEEE 802.11g (ANT 1)				
Channel	Frequency (MHz)	Measure Level (dBc)	Limit (dBc)	Result
1	2412	35.390	≥30	Pass
6	2437	48.360	≥30	Pass
11	2462	48.270	≥30	Pass

Channel 1 (2412MHz)

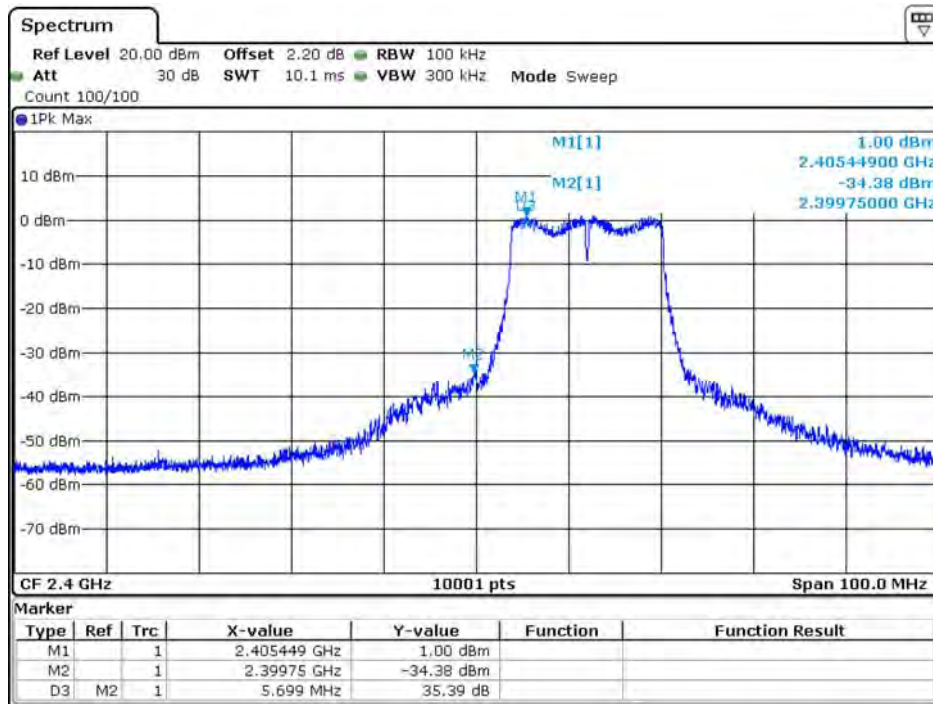

Date: 12 MAY 2020 17:39:17

Channel 6 (2437MHz)

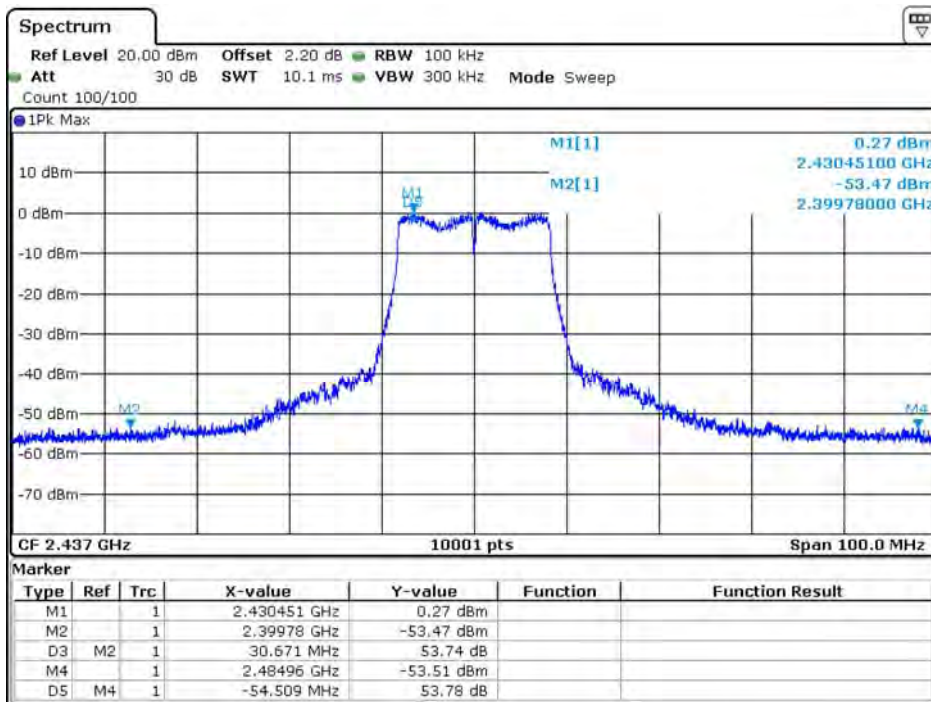

Date: 12 MAY 2020 17:37:13

Channel 11 (2462MHz)

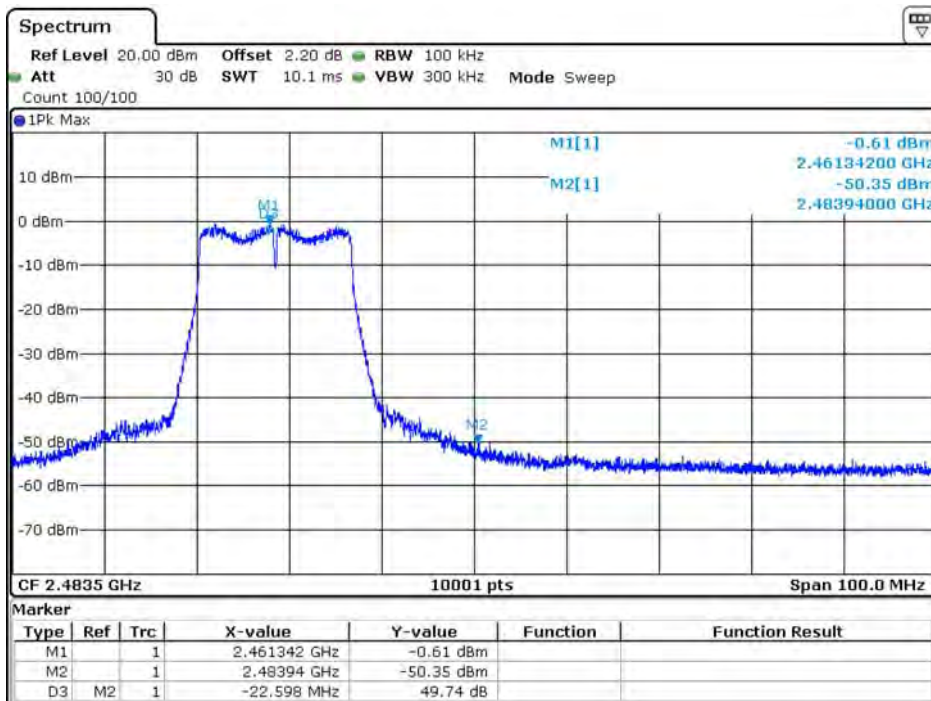

Date: 12 MAY 2020 17:33:28

Product	Venation E2 IoT Gateway		
Test Item	RF antenna conducted test		
Test Mode	Mode 1: Transmit_CDD		
Date of Test	2020/05/12	Test Site	SR12-H
Temperature(°C)	23	Humidity (%RH)	60

IEEE 802.11n 20M (ANT 0)				
Channel	Frequency (MHz)	Measure Level (dBc)	Limit (dBc)	Result
1	2412	37.340	≥30	Pass
6	2437	47.180	≥30	Pass
11	2462	46.610	≥30	Pass

Channel 1 (2412MHz)

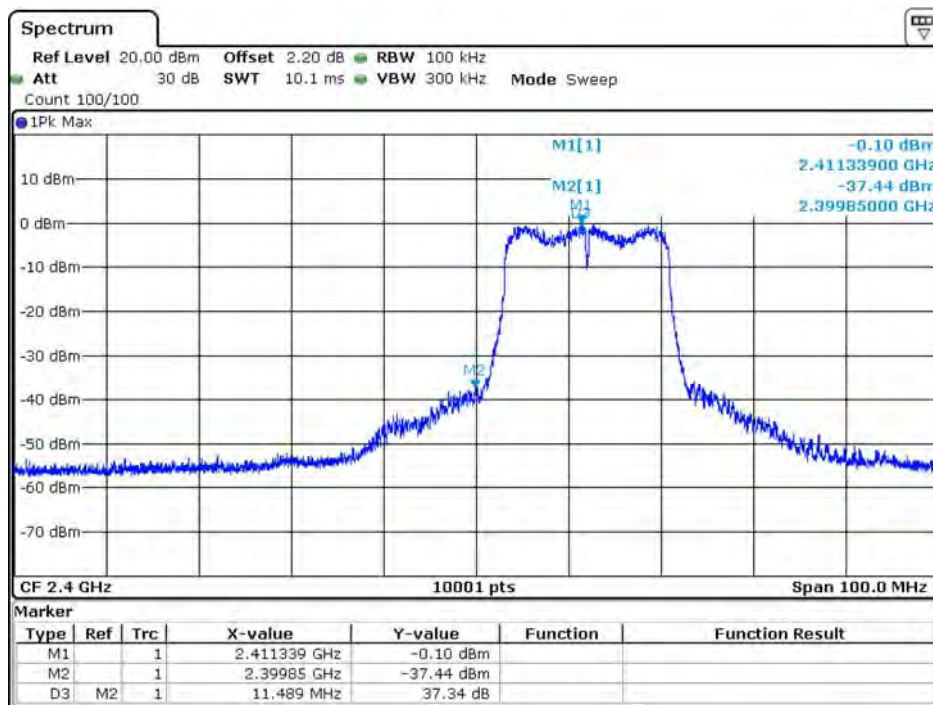

Date: 12 MAY 2020 17:24:22

Channel 6 (2437MHz)

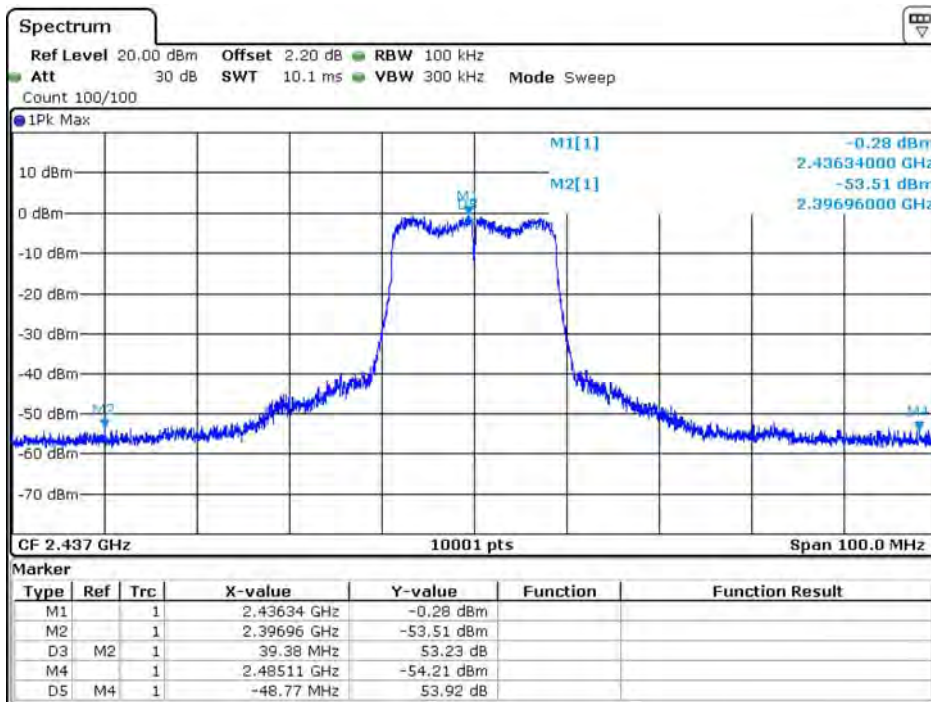

Date: 12 MAY 2020 17:24:56

Channel 11 (2462MHz)

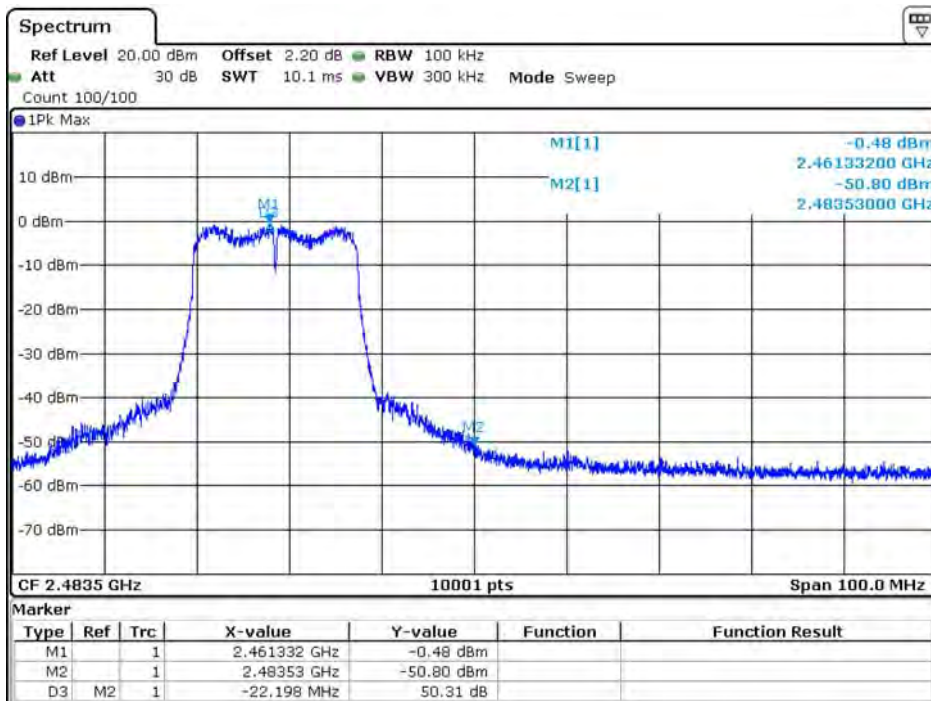

Date: 12 MAY 2020 17:26:54

Product	Venation E2 IoT Gateway		
Test Item	RF antenna conducted test		
Test Mode	Mode 1: Transmit_CDD		
Date of Test	2020/05/12	Test Site	SR12-H
Temperature(°C)	23	Humidity (%RH)	60

IEEE 802.11n 20M (ANT 1)				
Channel	Frequency (MHz)	Measure Level (dBc)	Limit (dBc)	Result
1	2412	37.100	≥30	Pass
6	2437	48.300	≥30	Pass
11	2462	47.530	≥30	Pass

Channel 1 (2412MHz)

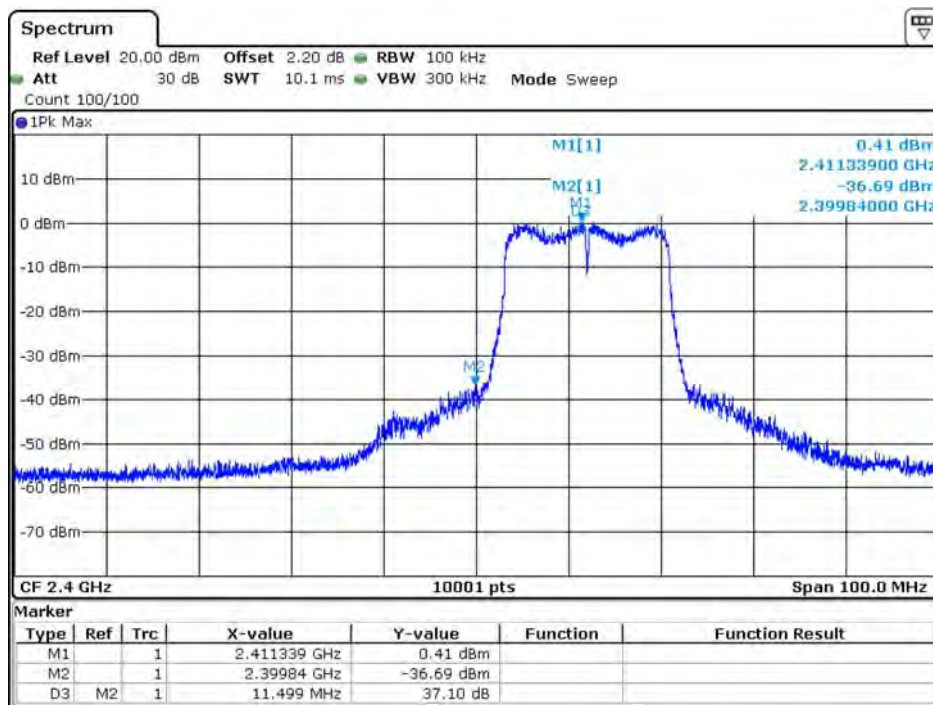

Date: 12 MAY 2020 17:23:03

Channel 6 (2437MHz)

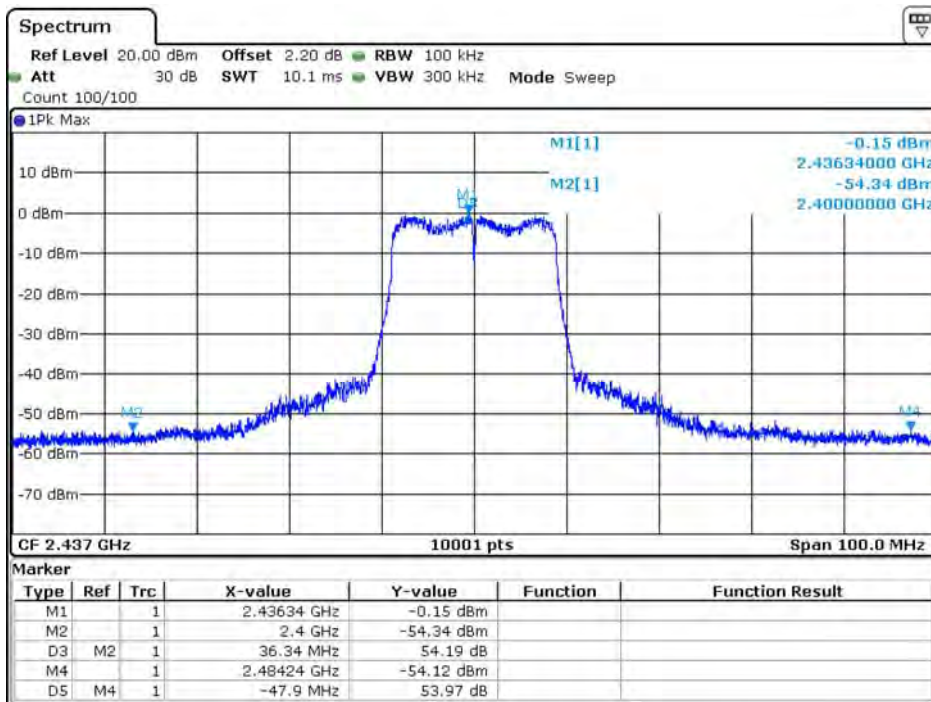

Date: 12 MAY 2020 17:25:28

Channel 11 (2462MHz)

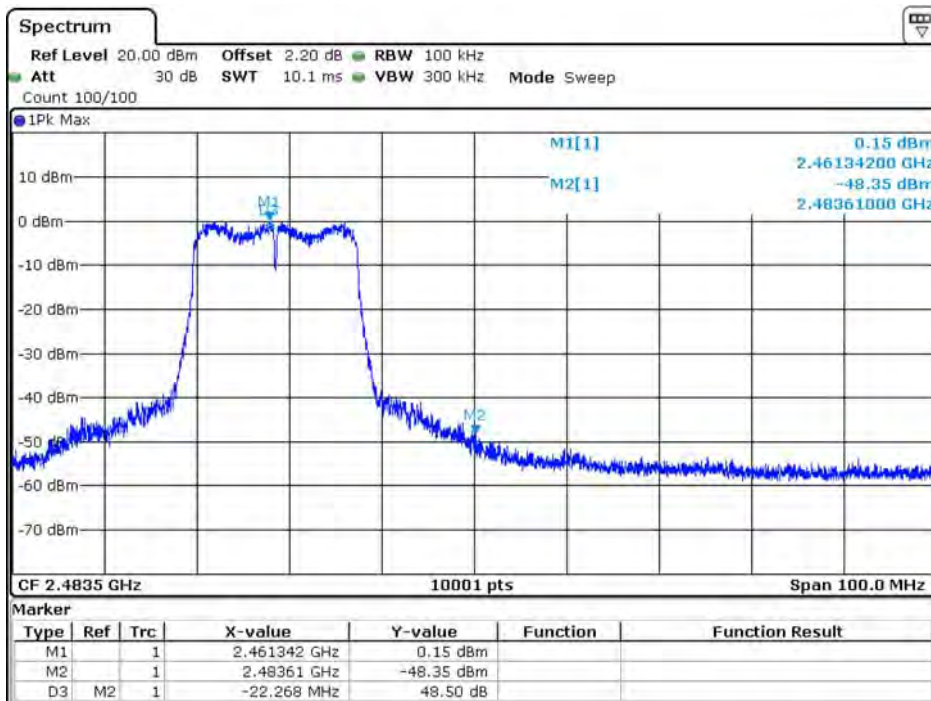

Date: 12 MAY 2020 17:26:25

Product	Venation E2 IoT Gateway		
Test Item	RF antenna conducted test		
Test Mode	Mode 1: Transmit_CDD		
Date of Test	2020/05/12	Test Site	SR12-H
Temperature(°C)	23	Humidity (%RH)	60

IEEE 802.11n 40M (ANT 0)				
Channel	Frequency (MHz)	Measure Level (dBc)	Limit (dBc)	Result
3	2422	35.910	≥30	Pass
6	2437	37.220	≥30	Pass
9	2452	42.260	≥30	Pass

Channel 3 (2422MHz)

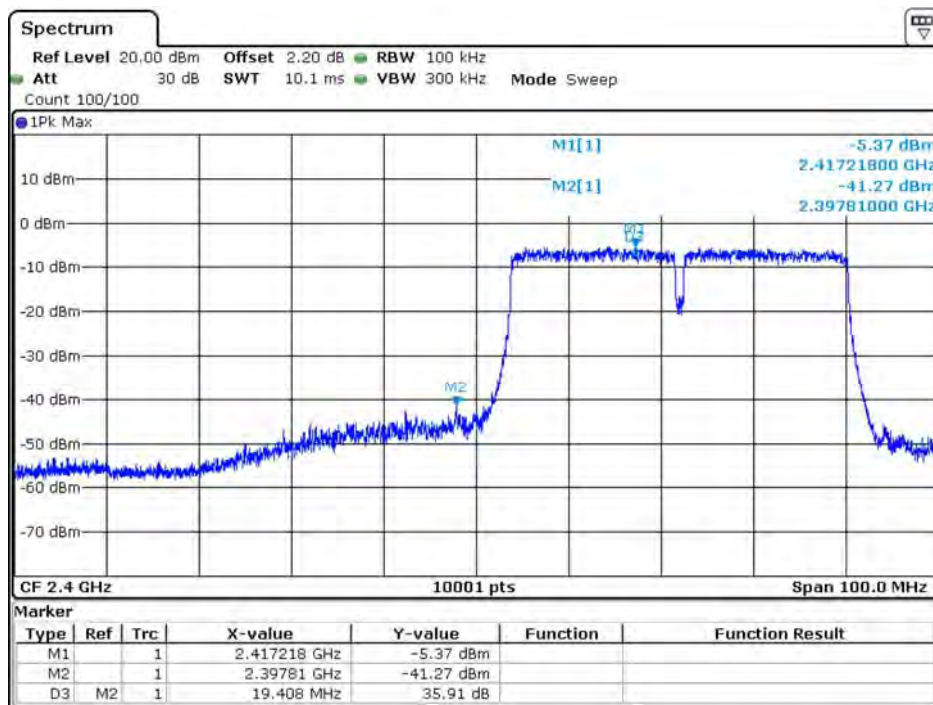

Date: 12 MAY 2020 17:21:21

Channel 6 (2437MHz)

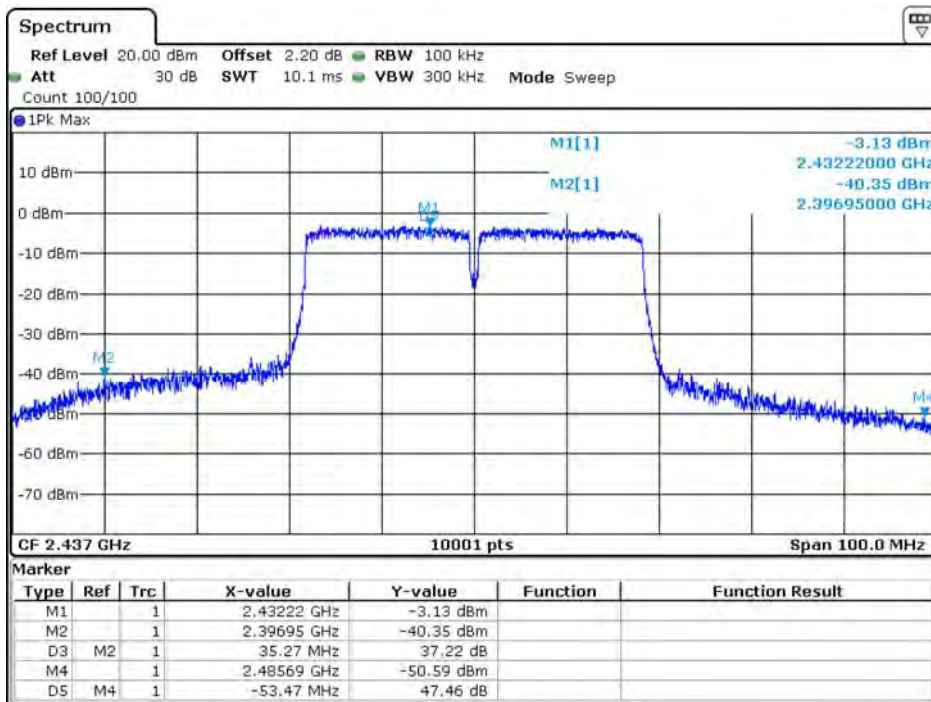

Date: 12 MAY 2020 17:20:07

Channel 9 (2452MHz)

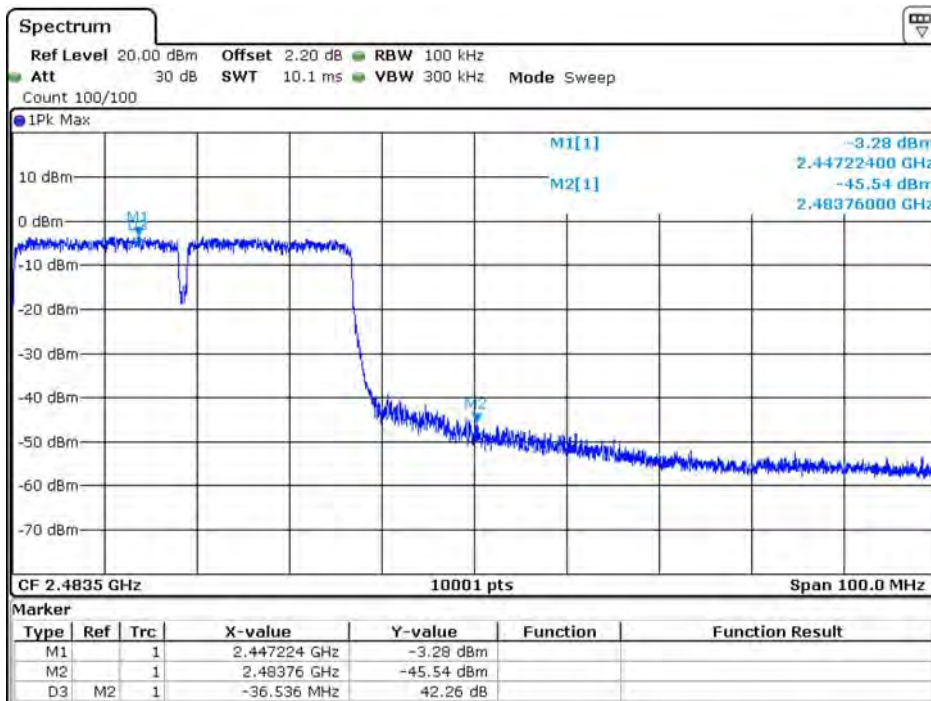

Date: 12 MAY 2020 17:08:48

Product	Venation E2 IoT Gateway		
Test Item	RF antenna conducted test		
Test Mode	Mode 1: Transmit_CDD		
Date of Test	2020/05/12	Test Site	SR12-H
Temperature(°C)	23	Humidity (%RH)	60

IEEE 802.11n 40M (ANT 1)				
Channel	Frequency (MHz)	Measure Level (dBc)	Limit (dBc)	Result
3	2422	38.080	≥30	Pass
6	2437	36.750	≥30	Pass
9	2452	42.000	≥30	Pass

Channel 3 (2422MHz)

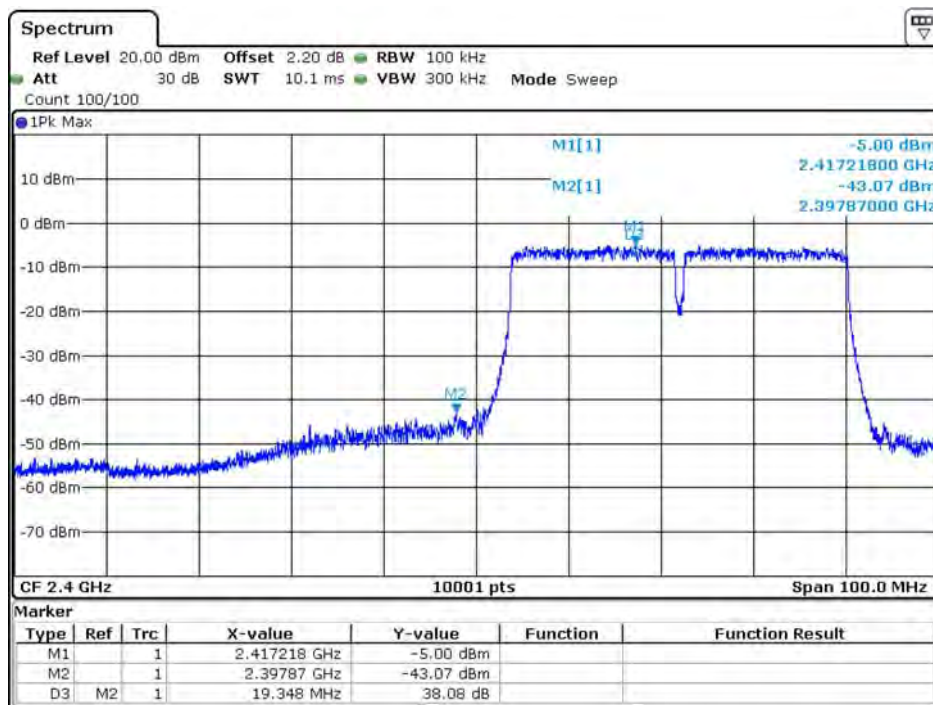

Date: 12 MAY 2020 17:22:08

Channel 6 (2437MHz)

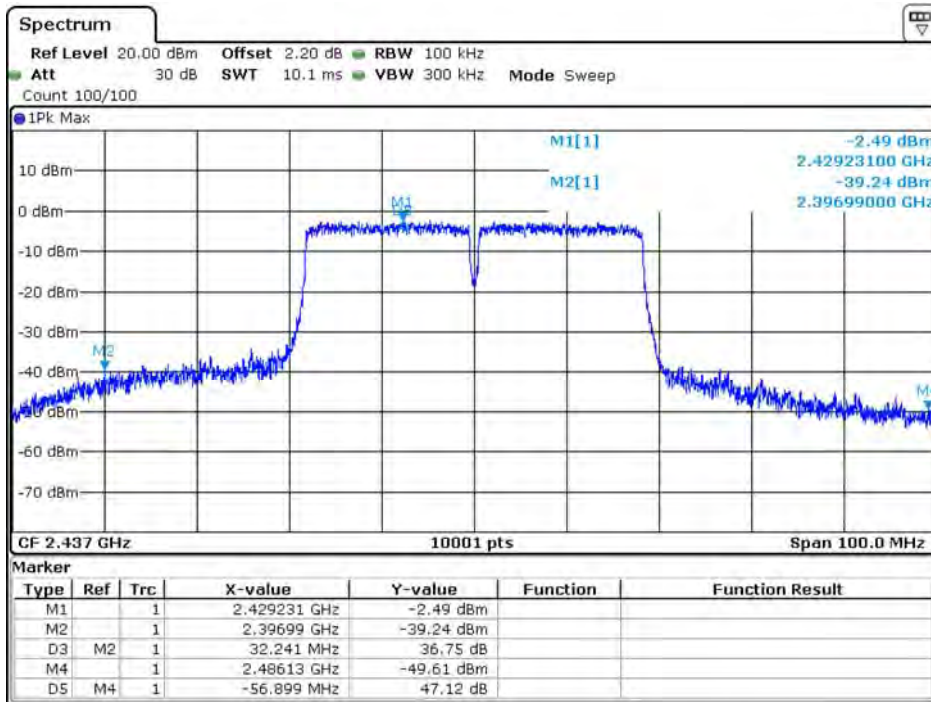

Date: 12 MAY 2020 17:19:26

Channel 9 (2452MHz)

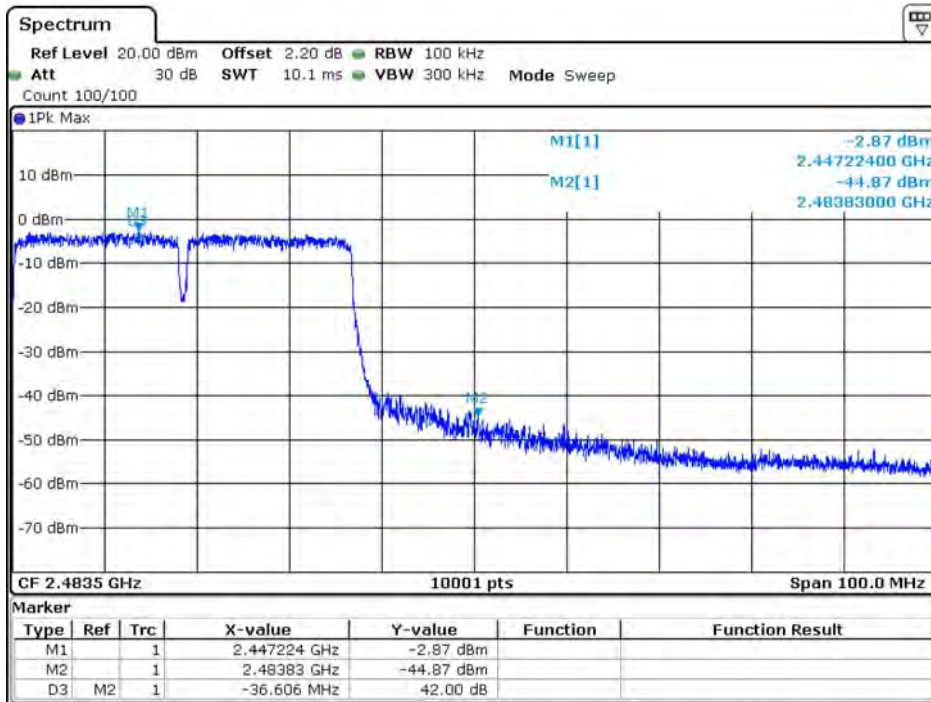

Date: 12 MAY 2020 17:10:01

Product	Venation E2 IoT Gateway		
Test Item	RF antenna conducted test		
Test Mode	Mode 1: Transmit_CDD		
Date of Test	2020/05/12	Test Site	SR12-H
Temperature(°C)	23	Humidity (%RH)	60

2412MHz (30MHz-25GHz)-802.11b-ANT 0

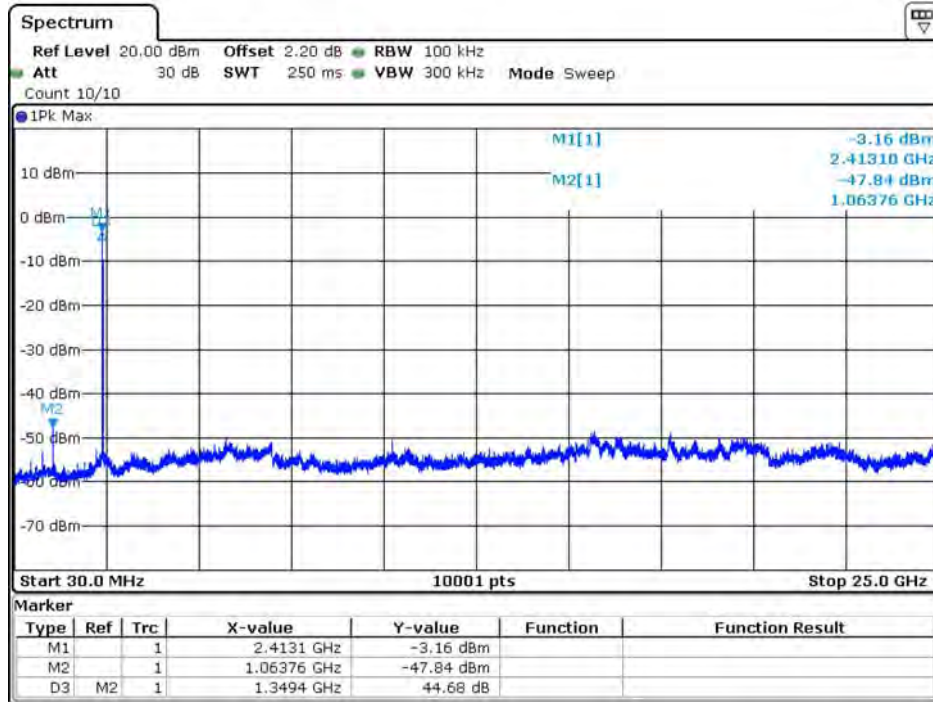

Date: 12 MAY 2020 17:53:49

2437MHz (30MHz-25GHz)-802.11b-ANT 0

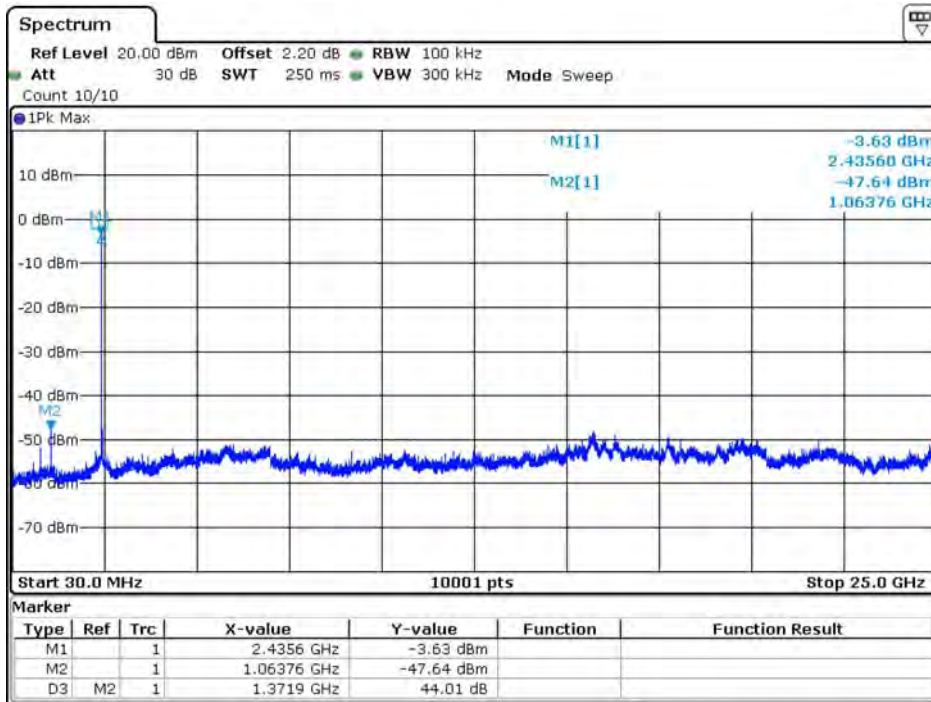

Date: 12 MAY 2020 17:49:15

2462MHz (30MHz-25GHz)-802.11b-ANT 0

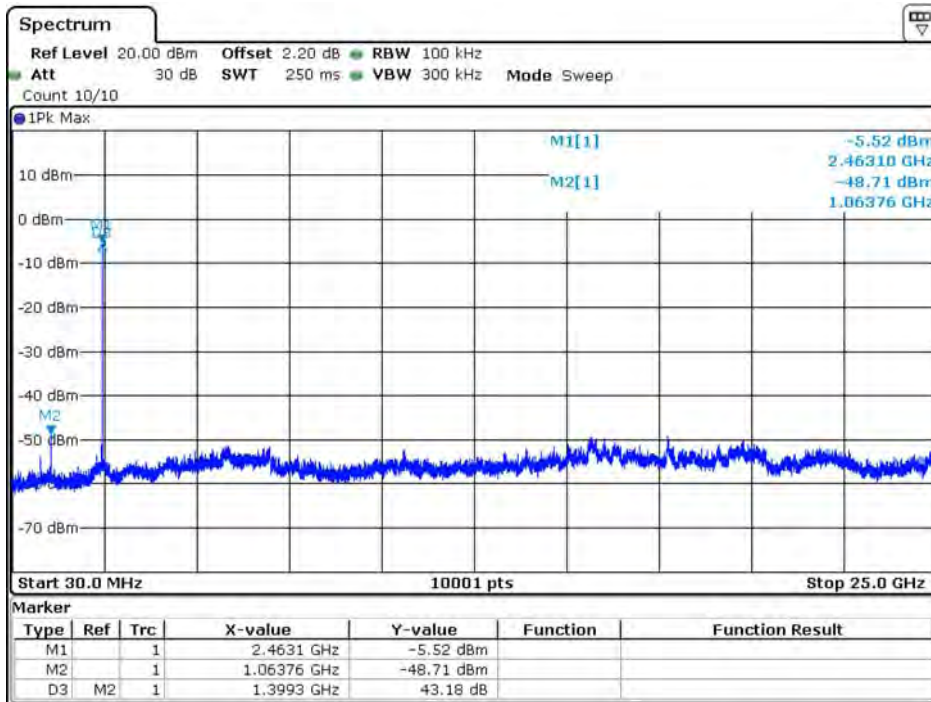

Date: 12 MAY 2020 17:47:42

2412MHz (30MHz-25GHz)-802.11b-ANT 1

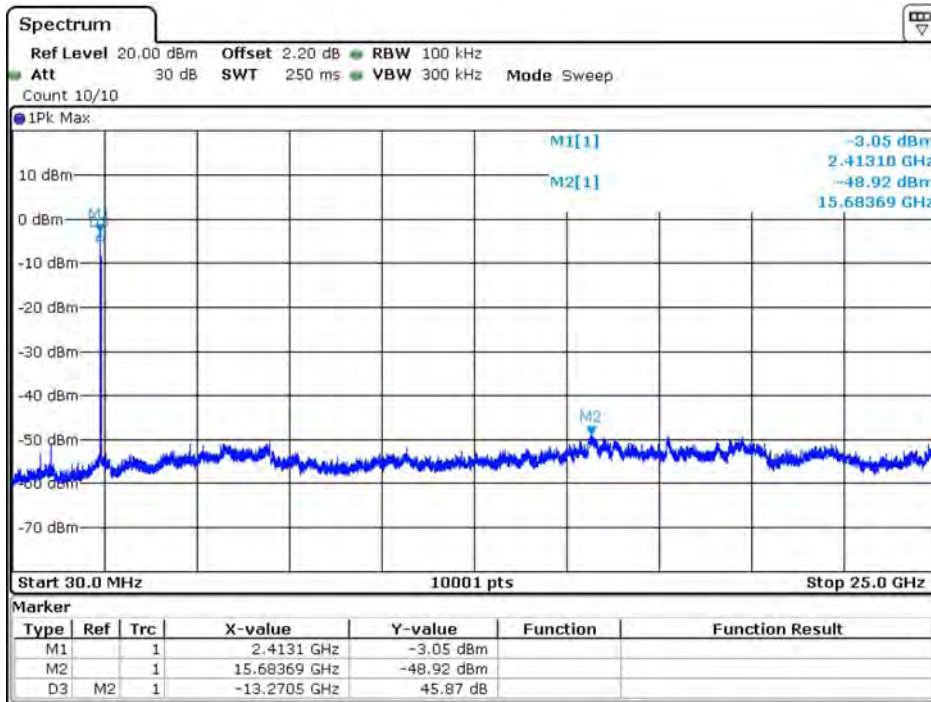

Date: 12 MAY 2020 17:52:28

2437MHz (30MHz-25GHz)-802.11b-ANT 1

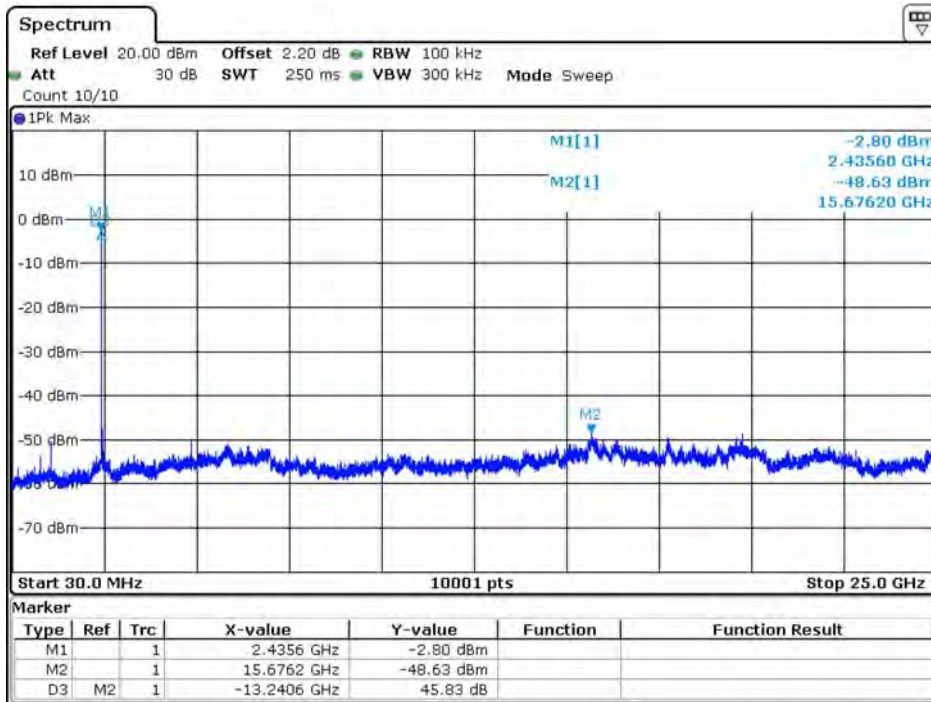

Date: 12 MAY 2020 17:49:57

2462MHz (30MHz-25GHz)-802.11b-ANT 1

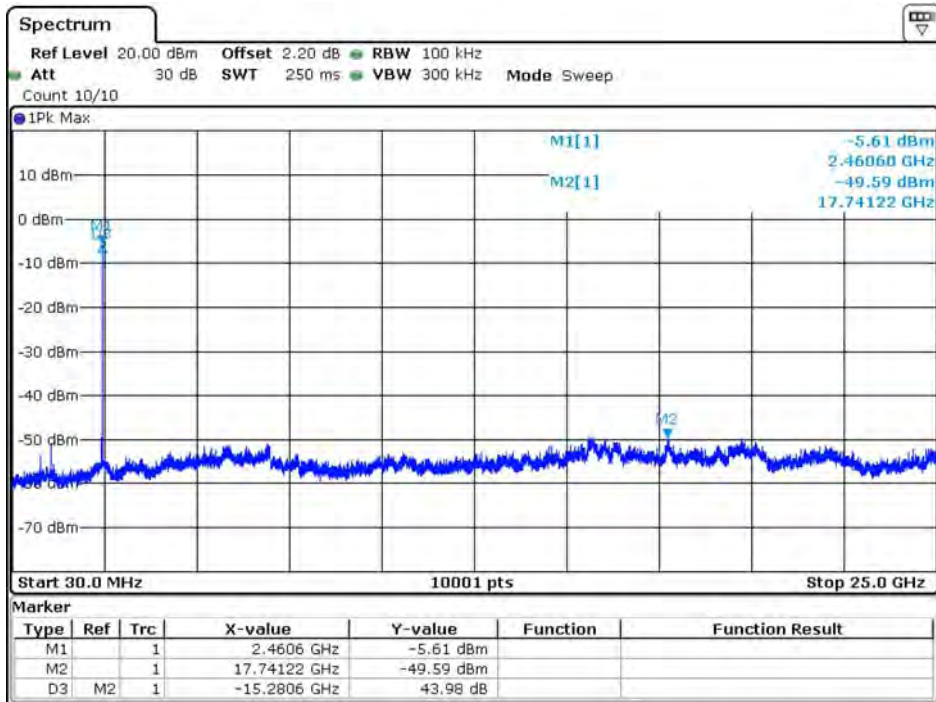

Date: 12 MAY 2020 17:46:59

2412MHz (30MHz-25GHz)-802.11g-ANT 0

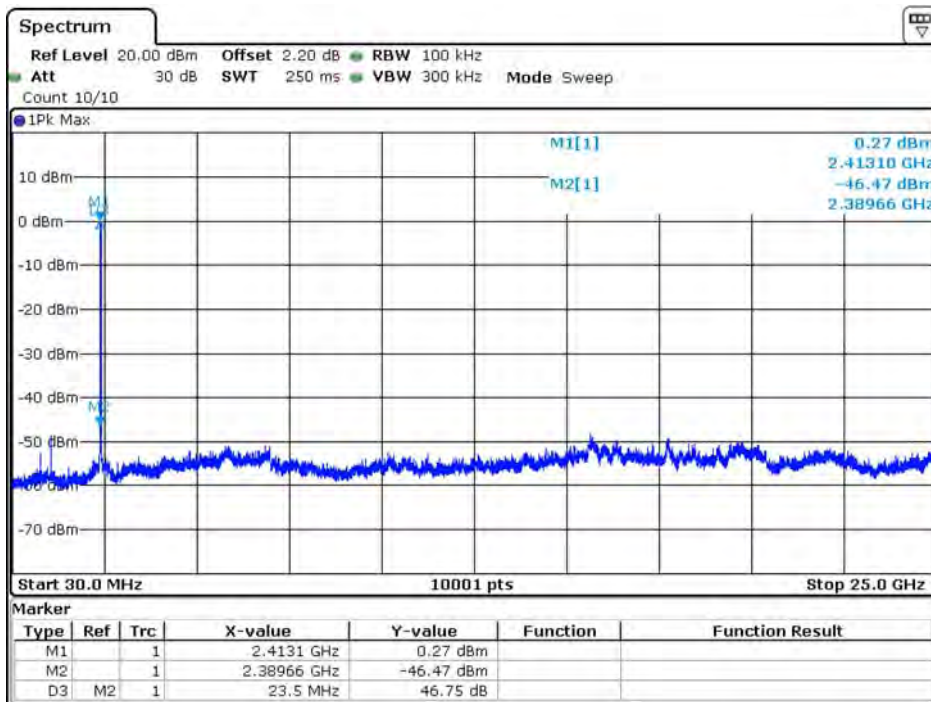

Date: 12 MAY 2020 17:56:33

2437MHz (30MHz-25GHz)-802.11g-ANT 0

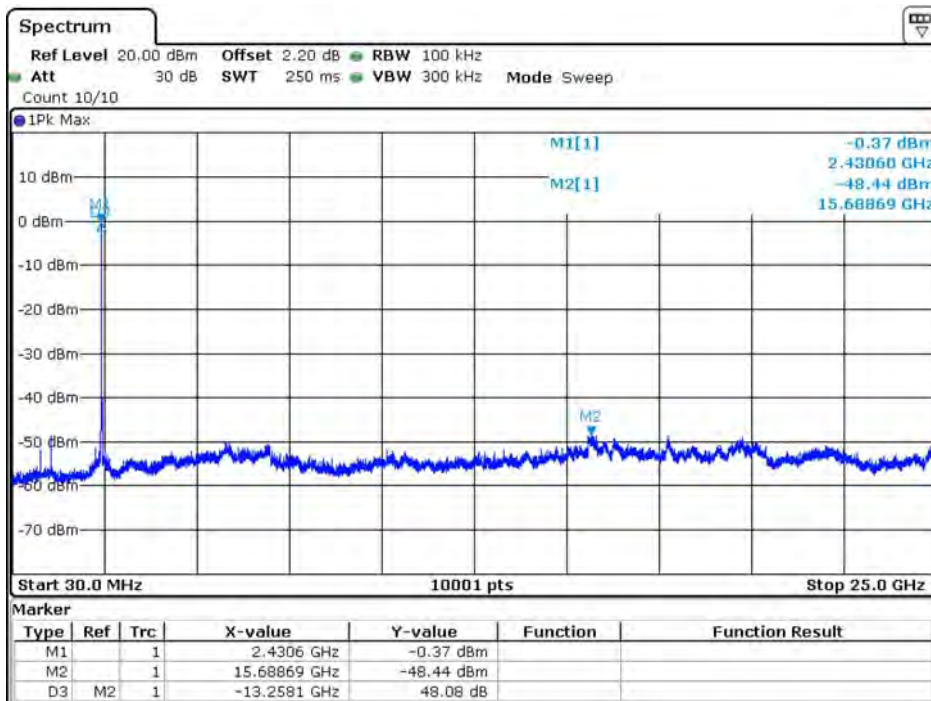

Date: 12 MAY 2020 18:01:16

2462MHz (30MHz-25GHz)-802.11g-ANT 0

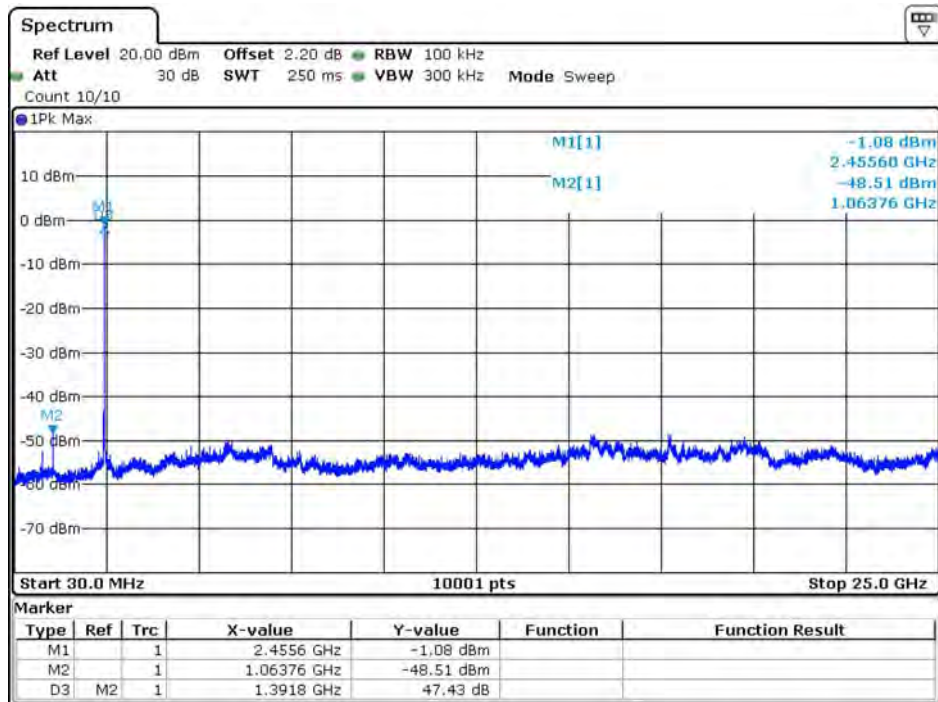

Date: 12 MAY 2020 18:03:26

2412MHz (30MHz-25GHz)-802.11g-ANT 1

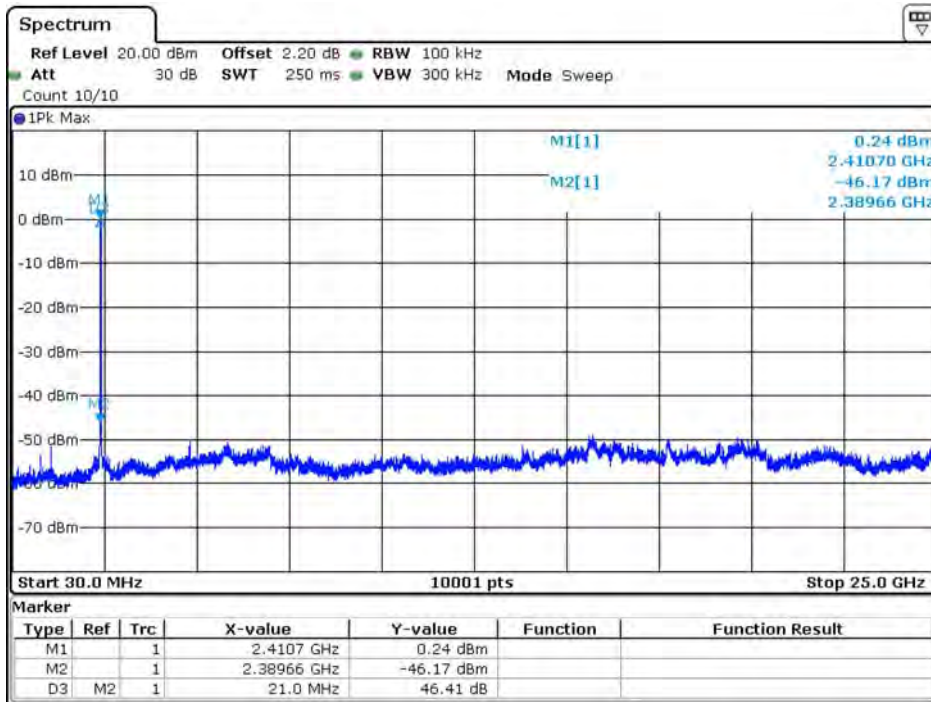

Date: 12 MAY 2020 17:57:22

2437MHz (30MHz-25GHz)-802.11g-ANT 1

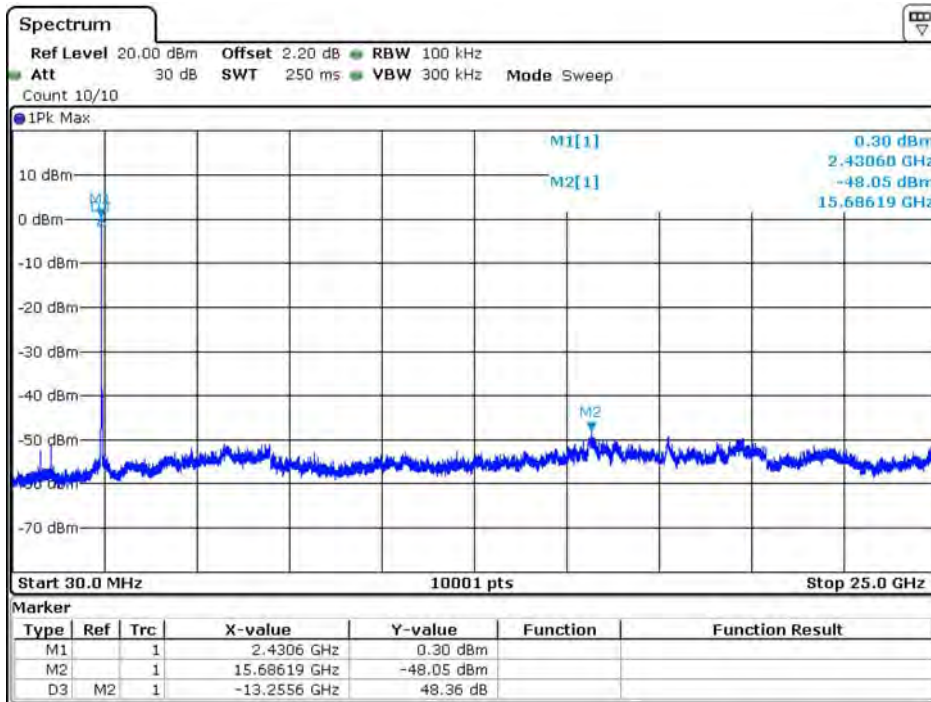

Date: 12 MAY 2020 17:58:28

2462MHz (30MHz-25GHz)-802.11g-ANT 1

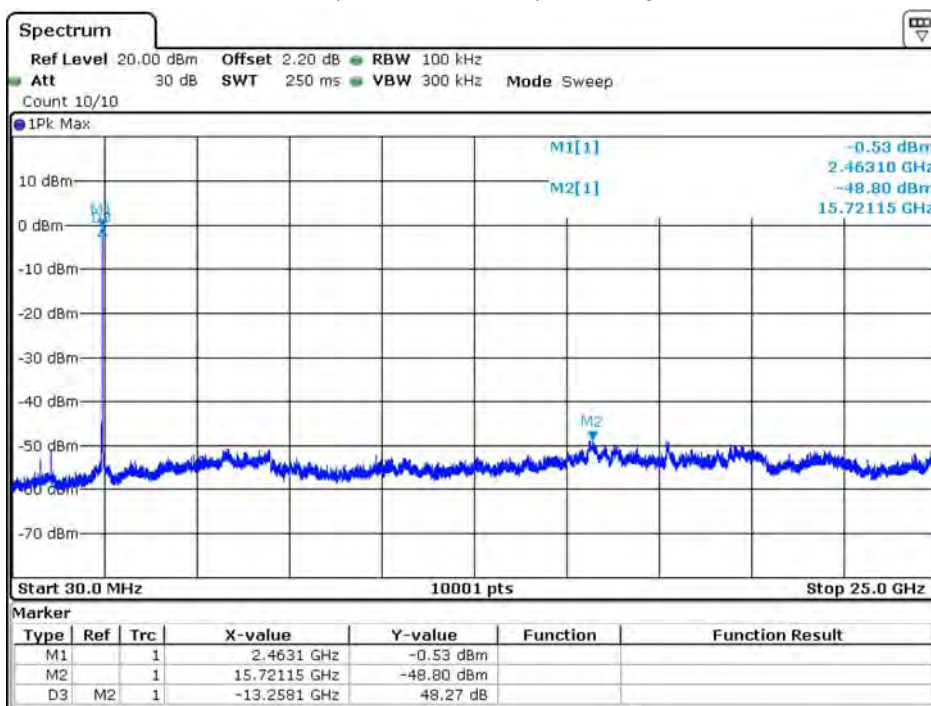

Date: 12 MAY 2020 18:04:47

2412MHz (30MHz-25GHz)-802.11n (20MHz)-ANT 0

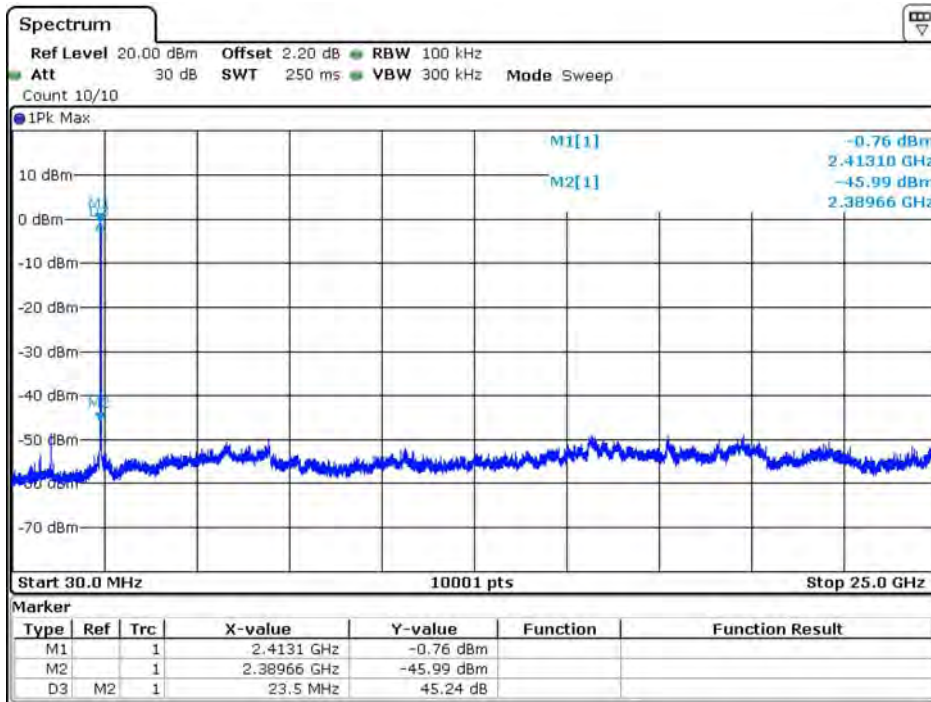

Date: 12 MAY 2020 18:15:29

2437MHz (30MHz-25GHz)-802.11n (20MHz)-ANT 0

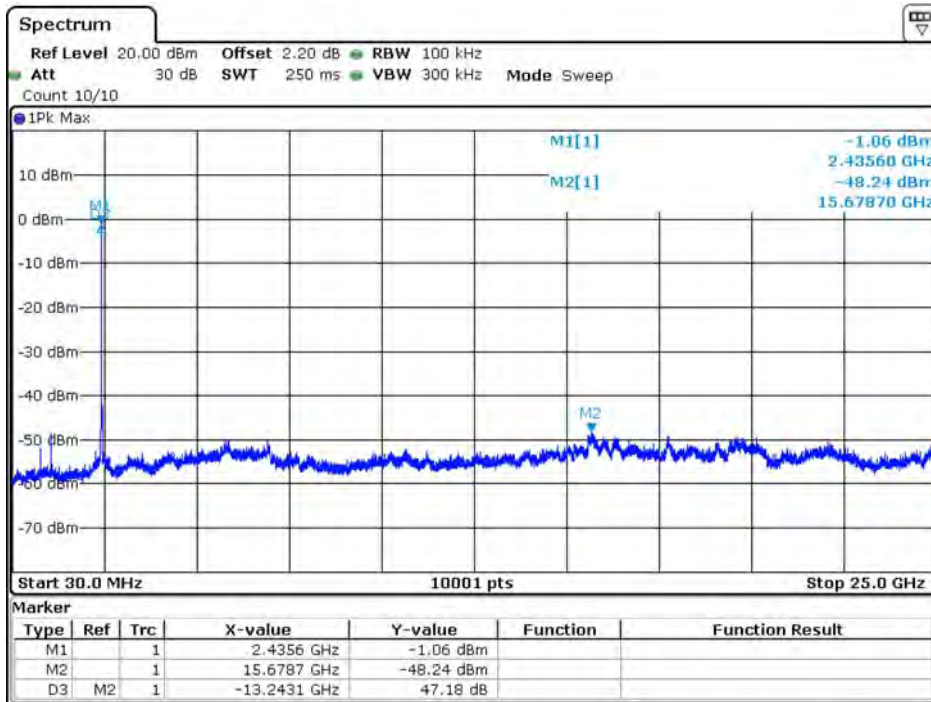

Date: 12 MAY 2020 18:10:40

2462MHz (30MHz-25GHz)-802.11n (20MHz)-ANT 0

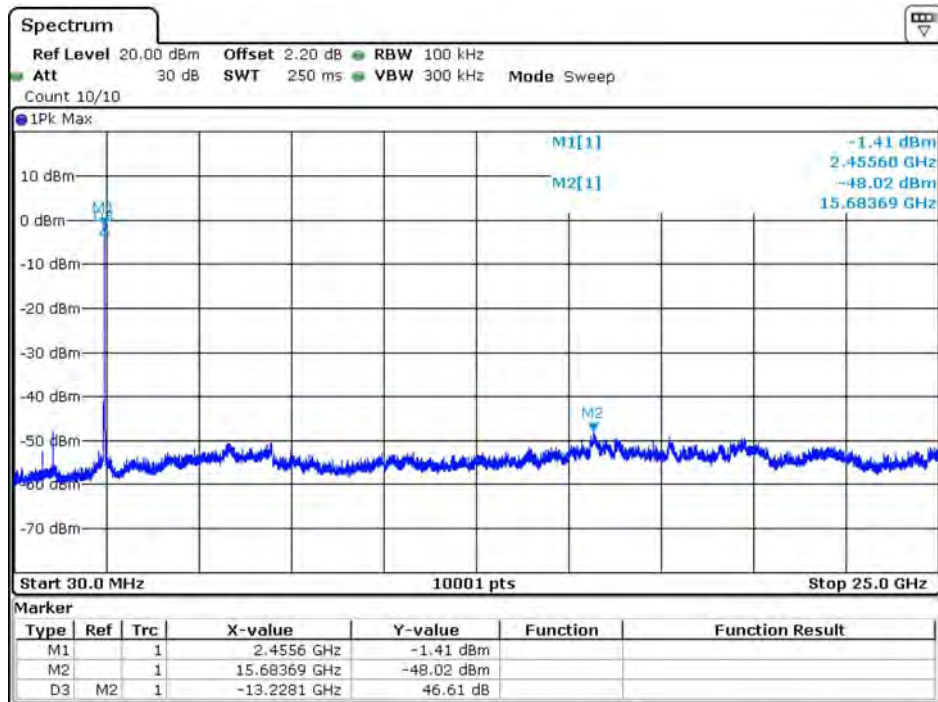

Date: 12 MAY 2020 18:08:24

2412MHz (30MHz-25GHz)-802.11n (20MHz)-ANT 1

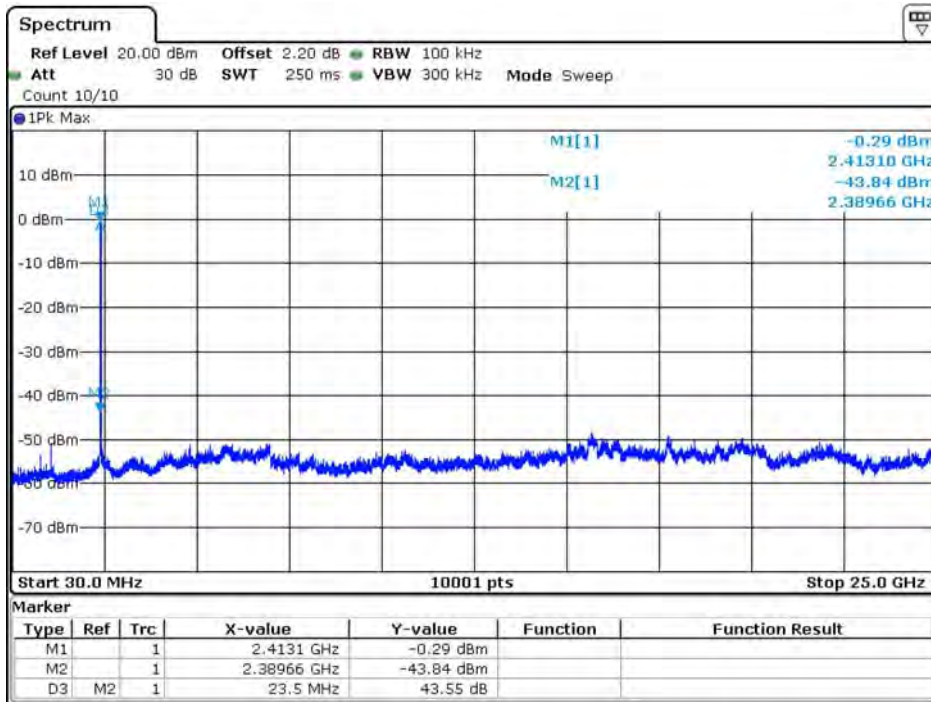

Date: 12 MAY 2020 18:14:05

2437MHz (30MHz-25GHz)-802.11n (20MHz)-ANT 1

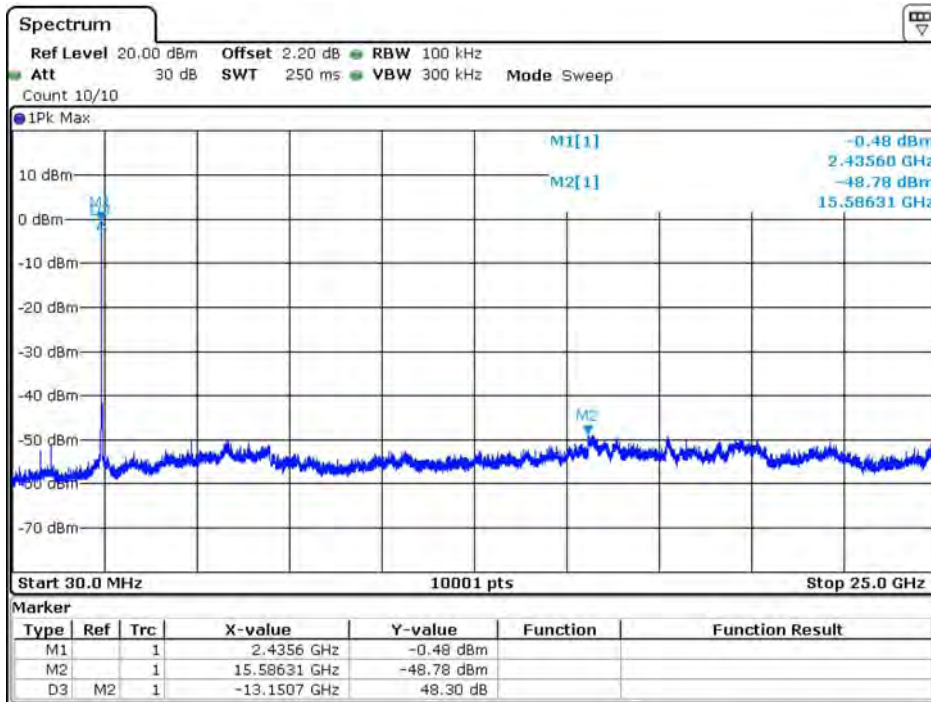

Date: 12 MAY 2020 18:12:19

2462MHz (30MHz-25GHz)-802.11n (20MHz)-ANT 1

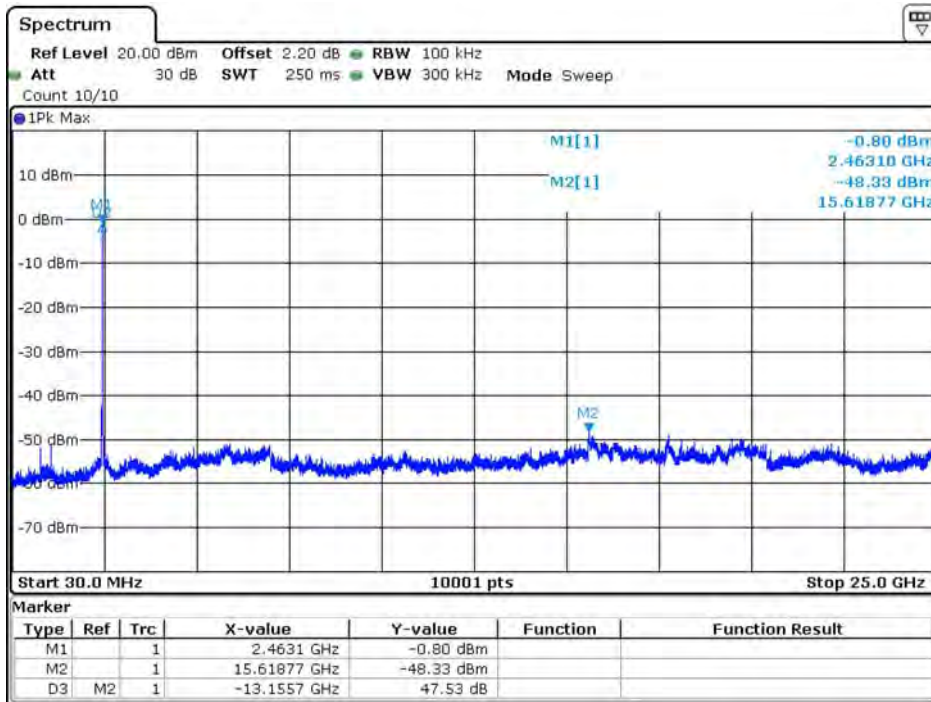

Date: 12 MAY 2020 18:06:21

2422MHz (30MHz-25GHz)-802.11n (40MHz)-ANT 0

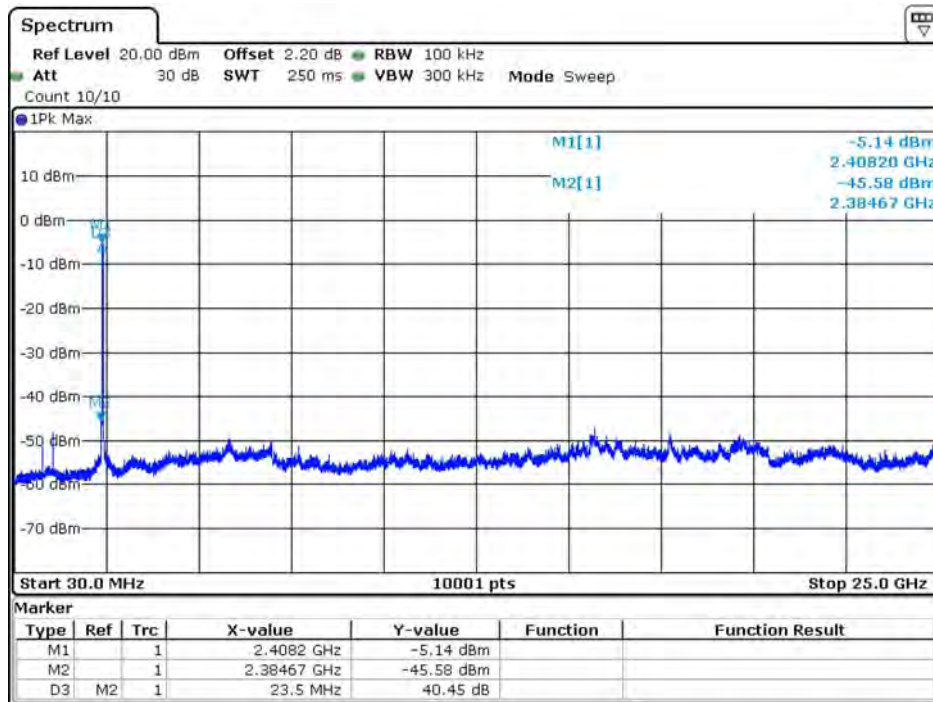

Date: 12 MAY 2020 18:18:54

2437MHz (30MHz-25GHz)-802.11n (40MHz)-ANT 0

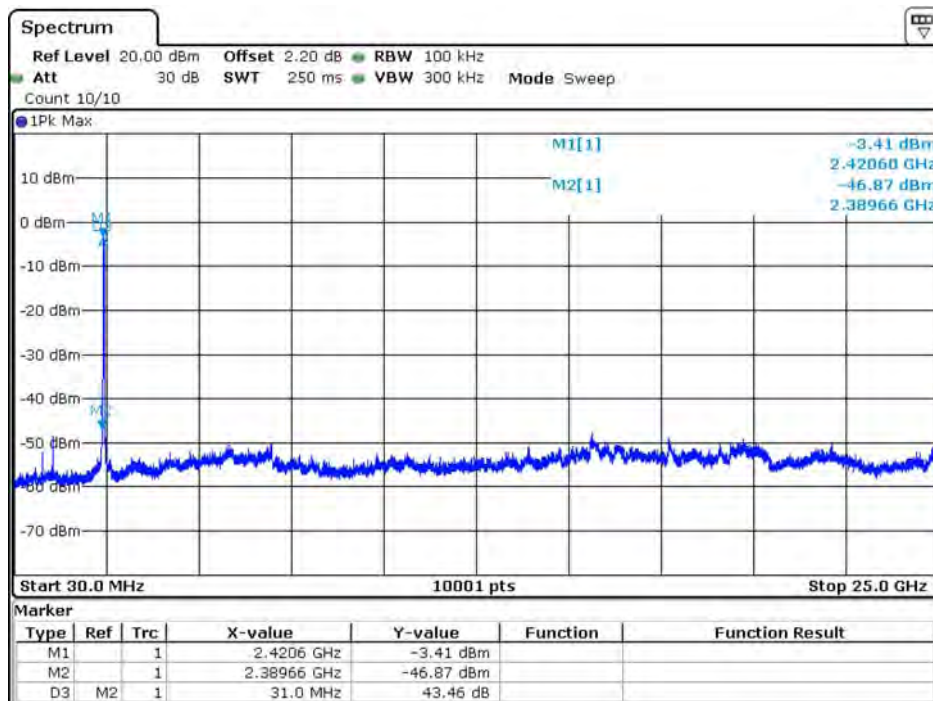

Date: 12 MAY 2020 18:23:35

2452MHz (30MHz-25GHz)-802.11n (40MHz)-ANT 0

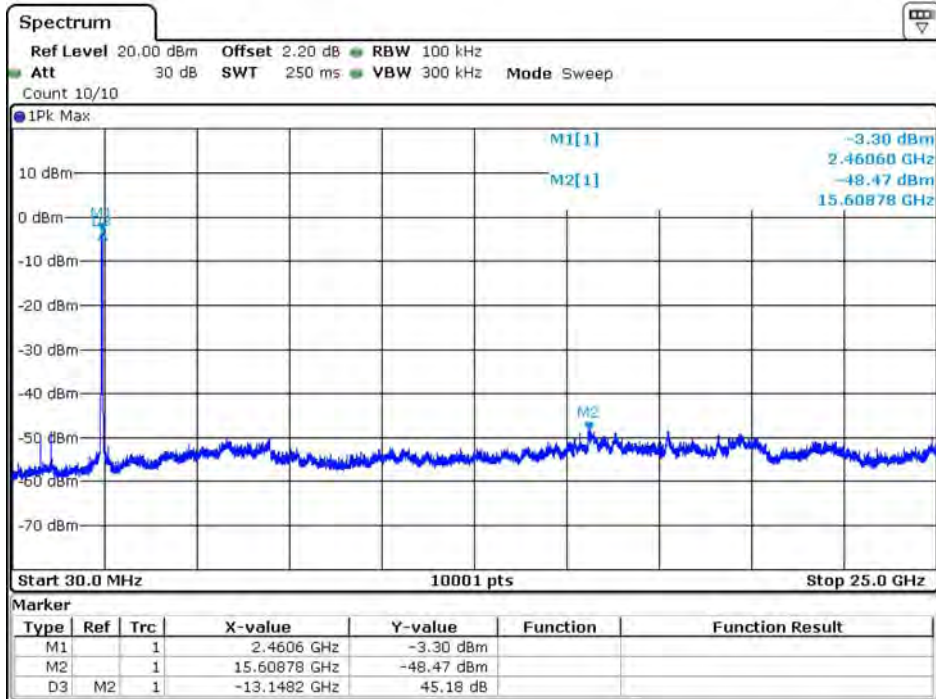

Date: 12 MAY 2020 18:27:30

2422MHz (30MHz-25GHz)-802.11n (40MHz)-ANT 1

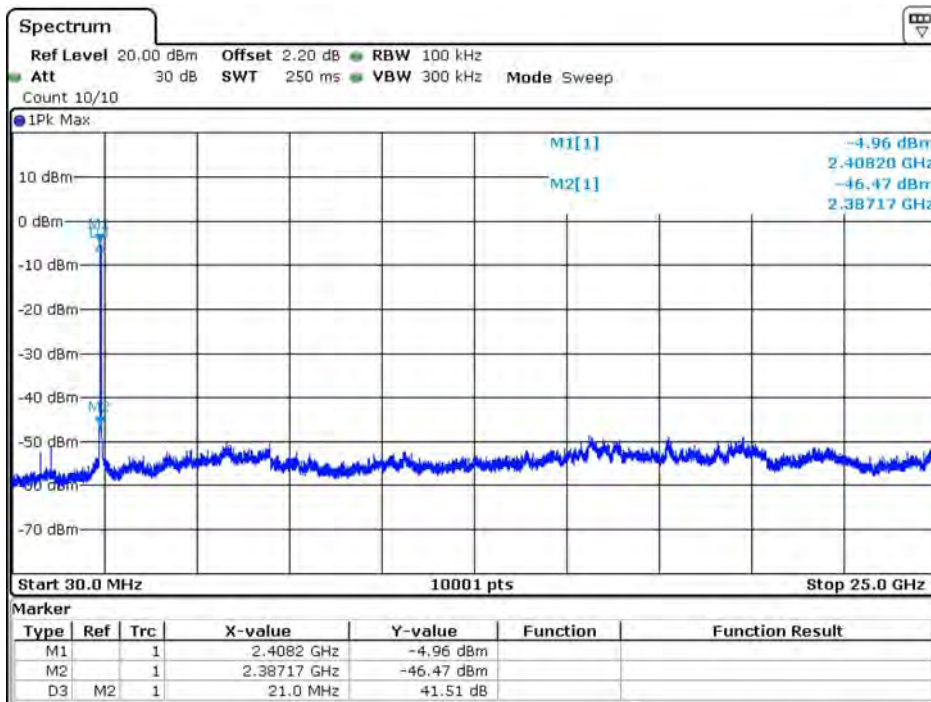

Date: 12 MAY 2020 18:20:30

2437MHz (30MHz-25GHz)-802.11n (40MHz)-ANT 1

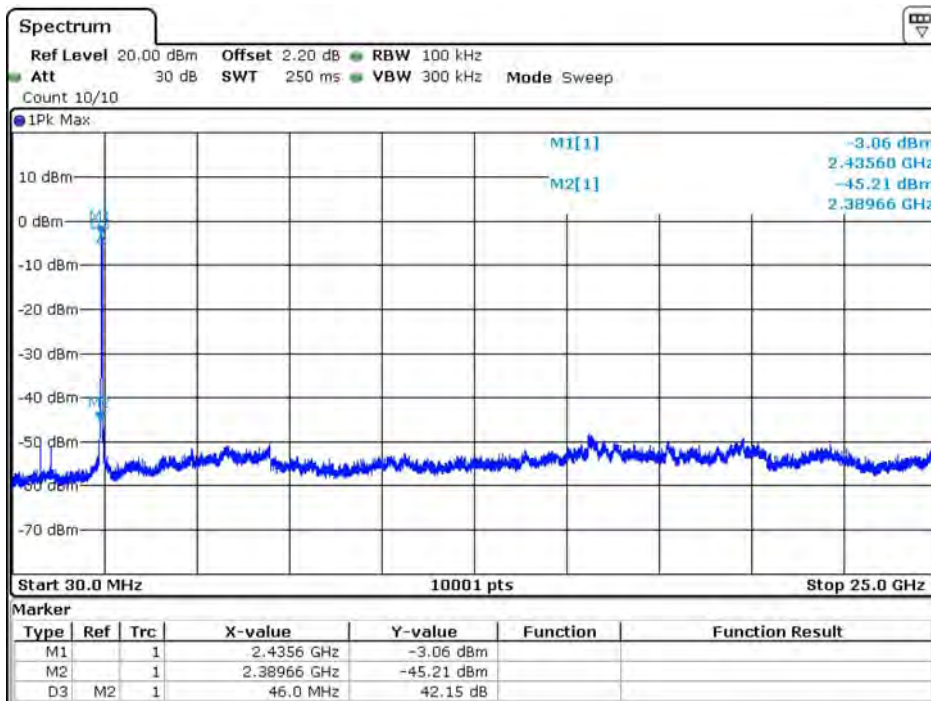

Date: 12 MAY 2020 18:22:04

2452MHz (30MHz-25GHz)-802.11n (40MHz)-ANT 1

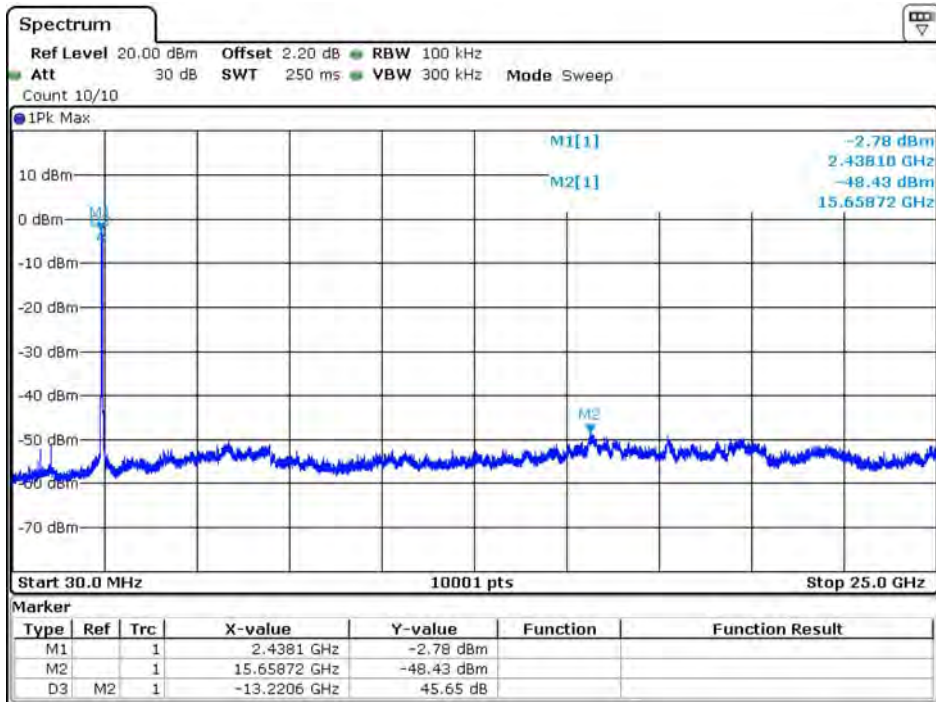

Date: 12 MAY 2020 18:29:34