

FCC TEST REPORT

For

Mobile Phone

Model Number: V2352

FCC ID: 2AUCY-V2352

Report Number : WT248000642

Test Laboratory : Shenzhen Academy of Metrology and Quality
Inspection
Site Location : No.4, Tongfa Road, Xili Street, Nanshan District,
Shenzhen, Guangdong, China
Tel : 0086-755-86928965
Fax : 0086-755-86009898-31396
Web : www.smq.com.cn
E-mail : emcrf@smq.com.cn

Revision History

| No | Date | Remark |
|------|------------|---------------|
| V1.0 | 2024.04.24 | Initial issue |

TEST REPORT DECLARATION

Applicant : vivo Mobile Communication Co., Ltd.
Address : No.1, vivo Road, Chang'an, Dongguan, Guangdong, China
Manufacturer : vivo Mobile Communication Co., Ltd.
Address : No.1, vivo Road, Chang'an, Dongguan, Guangdong, China
EUT Description : Mobile Phone
Model No. : V2352
Trade mark : vivo
FCC ID : 2AUCY-V2352

Test Standards:

FCC Part 15 Subpart E 15.407

The EUT described above is tested by Shenzhen Academy of Metrology and Quality Inspection EMC Laboratory to determine the maximum emissions from the EUT. Shenzhen Academy of Metrology and Quality Inspection EMC Laboratory is assumed full responsibility for the accuracy of the test results, unless they depend on the manufacturer information.

The test report is valid for above tested sample only and shall not be reproduced in part without written approval of the laboratory.

| | | | |
|-------------------|---|-------|---------------------|
| Project Engineer: |  (Chen Silin 陈司林) | Date: | <u>Apr.24, 2024</u> |
| Checked by: |  (Wan Xiaojing 万晓婧) | Date: | <u>Apr.24, 2024</u> |
| Approved by: |  (Lin Bin 林斌) | Date: | <u>Apr.24, 2024</u> |

TABLE OF CONTENTS

| | |
|--|-----------|
| TEST REPORT DECLARATION | 3 |
| 1. TEST RESULTS SUMMARY | 5 |
| 2. GENERAL INFORMATION | 6 |
| 2.1. Report information..... | 6 |
| 2.2. Laboratory Accreditation and Relationship to Customer | 6 |
| 3. PRODUCT DESCRIPTION..... | 7 |
| 3.1. EUT Description..... | 7 |
| 3.2. Related Submittal(s) / Grant (s) | 8 |
| 3.3. Block Diagram of EUT Configuration | 8 |
| 3.4. Operating Condition of EUT | 9 |
| 3.5. Support Equipment List | 9 |
| 3.6. Test Conditions..... | 9 |
| 3.7. Special Accessories..... | 10 |
| 3.8. Equipment Modifications | 10 |
| 4. TEST EQUIPMENT USED | 11 |
| 5. TRANSMIT POWER CONTROL | 12 |
| 5.1. LIMITS OF TRANSMIT POWER CONTROL..... | 12 |
| 5.2. TEST DATA..... | 12 |
| 6. DYNAMIC FREQUENCY SELECTION | 13 |
| 6.1. LIMITS OF DYNAMIC FREQUENCY SELECTION | 13 |
| 6.2. TEST PROCEDURE..... | 16 |
| 6.3. TEST DATA..... | 16 |

1. TEST RESULTS SUMMARY

Table 1 Test Results Summary

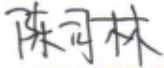
| Test Items | FCC Rules | Test Results |
|-----------------------------------|-----------------|--------------|
| Transmit Power Control | FCC §15.407 (h) | N/A |
| Channel Closing Transmission Time | FCC §15.407 (h) | Pass |
| Channel Move Time | FCC §15.407 (h) | Pass |
| Non-Occupancy Period | FCC §15.407 (h) | Pass |

Remark: "N/A" means "Not applicable."

2. GENERAL INFORMATION

2.1. Report information

This report is not a certificate of quality; it only applies to the sample of the specific product/equipment given at the time of its testing. The results are not used to indicate or imply that they are application to the similar items. In addition, such results must not be used to indicate or imply that SMQ approves recommends or endorses the manufacture, supplier or use of such product/equipment, or that SMQ in any way guarantees the later performance of the product/equipment.

The sample/s mentioned in this report is/are supplied by Applicant, SMQ therefore assumes no responsibility for the accuracy of information on the brand name, model number, origin of manufacture or any information supplied.

Additional copies of the report are available to the Applicant at an additional fee. No third part can obtain a copy of this report through SMQ, unless the applicant has authorized SMQ in writing to do so.

The lab will not be liable for any loss or damage resulting for false, inaccurate, inappropriate or incomplete product information provided by the applicant/manufacturer.

2.2. Laboratory Accreditation and Relationship to Customer

The testing report were performed by the Shenzhen Academy of Metrology and quality Inspection EMC Laboratory (Guangdong EMC compliance testing center), in their facilities located at NETC Building, No.4 Tongfa Rd., Xili, Nanshan, Shenzhen, China. At the time of testing, Laboratory is accredited by the following organizations:

China National Accreditation Service for Conformity Assessment (CNAS) accredits the Laboratory for conformance to FCC standards, EMC international standards and EN standards. The Registration Number is CNAS L0579.

The Laboratory is Accredited Testing Laboratory of FCC with Designation number CN1165 and Site registration number 582918.

The Laboratory is registered to perform emission tests with Innovation, Science and Economic Development (ISED), and the registration number is 11177A.

The Laboratory is registered to perform emission tests with VCCI, and the registration number are C-20048, G20076, R-20077, R-20078 and T-20047.

The Laboratory is Accredited Testing Laboratory of American Association for Laboratory Accreditation (A2LA) and certificate number is 3292.01.

Table 6 Working Frequency List U-NII 2C (802.11n, 802.11ac (40MHz))

| Channel | Frequency | Channel | Frequency |
|---------|-----------|---------|-----------|
| 102 | 5510 MHz | 126 | 5630 MHz |
| 110 | 5550 MHz | 134 | 5670 MHz |
| 118 | 5590 MHz | -- | -- |

Table 7 Working Frequency List U-NII 2C (802.11ac (80MHz))

| Channel | Frequency | Channel | Frequency |
|---------|-----------|---------|-----------|
| 106 | 5530 MHz | 122 | 5610 MHz |

3.2. Related Submittal(s) / Grant (s)

This submittal(s) (test report) is intended for FCC ID: **2AUCY-V2352** filing to comply with Section 15.407 of the FCC Part 15 Subpart E.

3.3. Block Diagram of EUT Configuration

Setup for Master with injection at the Master

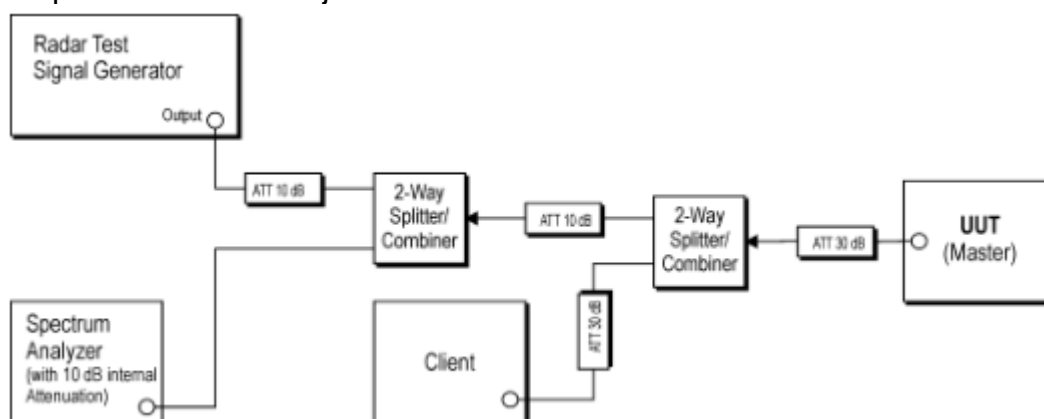

Figure 1 Example Conducted Setup where UUT is a Master and Radar Test Waveforms are injected into the Master

Setup for Client with injection at the Master

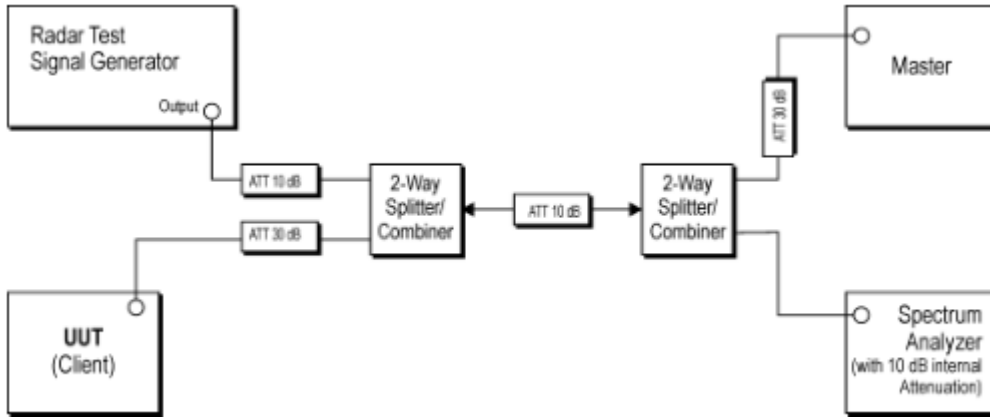

Figure 2 Example Conducted Setup where UUT is a Client and Radar Test Waveforms are injected into the Master

Setup for Client with injection at the Client

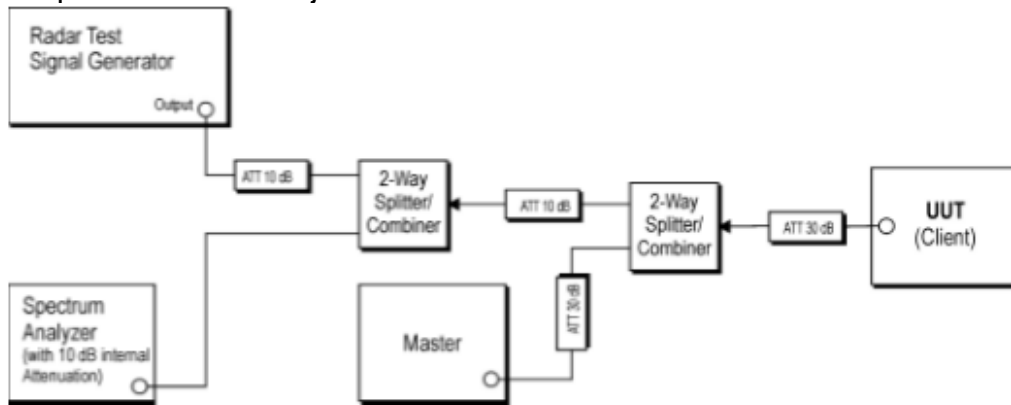

Figure 3 Example Conducted Setup where UUT is a Client and Radar Test Waveforms are injected into the Client

3.4. Operating Condition of EUT

The EUT utilizes the 802.11ac architecture. Three nominal channel bandwidths are implemented: 20MHz, 40MHz, 80MHz. Only test the widest BW: 80MHz.

3.5. Support Equipment List

Table 8 Support Equipment List

| Name | Model No. | S/N | Manufacturer | FCC |
|--|-----------|-----|--------------|----------------|
| Notebook | E460 | --- | Lenovo | DOC |
| Nighthawk X4S AC2600 Smart WiFi Router | R7800 | --- | NETGEAR | ID:PY315100319 |

3.6. Test Conditions

Date of test: Apr.19, 2024
 Date of EUT Receive: Apr.02, 2024
 Temperature: 25°C
 Relative Humidity: 50%

3.7. Special Accessories

Not available for this EUT intended for grant.

3.8. Equipment Modifications

Not available for this EUT intended for grant.

4. TEST EQUIPMENT USED

Table 9 Test Equipment

| No. | Equipment | Manufacturer | Model No. | Last Cal. | Cal. Interval |
|------------|---------------------------|--------------|-----------------|--------------|---------------|
| SB9060 | Spectrum Analyzer | R&S | FSQ40 | Apr.25, 2023 | 1 Year |
| SB11873/02 | Vector Signal Generator | R&S | SMBV100A | Apr.25, 2023 | 1 Year |
| SB11873/01 | Power sensor, Power Meter | R&S | OSP120+OSP-B157 | Apr.25, 2023 | 1 Year |
| SB11895 | Attenuator | Agilent | 8496B | Feb.27, 2024 | 1 Year |

Table 10 Test software

| Name | Manufacturer | Version |
|--------------------------------|------------------------------|---------|
| Bluetooth and WiFi Test System | Shenzhen JS tonscond co.,ltd | 3.3.10 |

5. TRANSMIT POWER CONTROL

5.1. LIMITS OF TRANSMIT POWER CONTROL

CFR 47 (FCC) part 15.2407 (h)(1)

U-NII devices operating in the 5.25-5.35 GHz band and the 5.47-5.725 GHz band shall employ a TPC mechanism. The U-NII device is required to have the capability to operate at least 6 dB below the mean EIRP value of 30 dBm. A TPC mechanism is not required for systems with an e.i.r.p. of less than 500 mW.

5.2. TEST DATA

N/A

6. DYNAMIC FREQUENCY SELECTION

6.1. LIMITS OF DYNAMIC FREQUENCY SELECTION

CFR 47 (FCC) part 15.407 (h) (1) and kdb905462 D02

Table 11 Applicability of DFS Requirements Prior to Use of a Channel

| Requirement | Operational Mode | | |
|---------------------------------|------------------|--------------------------------|-----------------------------|
| | Master | Client Without Radar Detection | Client With Radar Detection |
| Non-Occupancy Period | Yes | Not required | Yes |
| DFS Detection Threshold | Yes | Not required | Yes |
| Channel Availability Check Time | Yes | Not required | Not required |
| U-NII Detection Bandwidth | Yes | Not required | Yes |

Table 12 Applicability of DFS requirements during normal operation

| Requirement | Operational Mode | |
|-----------------------------------|--|--------------------------------|
| | Master Device or Client with Radar Detection | Client Without Radar Detection |
| DFS Detection Threshold | Yes | Not required |
| Channel Closing Transmission Time | Yes | Yes |
| Channel Move Time | Yes | Yes |
| U-NII Detection Bandwidth | Yes | Not required |

| Additional requirements for devices with multiple bandwidth modes | Master Device or Client with Radar Detection | Client Without Radar Detection |
|---|--|--|
| U-NII Detection Bandwidth and Statistical Performance Check | All BW modes must be tested | Not required |
| Channel Move Time and Channel Closing Transmission Time | Test using widest BW mode available | Test using the widest BW mode available for the link |
| All other tests | Any single BW mode | Not required |
| <p>Note: Frequencies selected for statistical performance check (Section 7.8.4) should include several frequencies within the radar detection bandwidth and frequencies near the edge of the radar detection bandwidth. For 802.11 devices it is suggested to select frequencies in each of the bonded 20 MHz channels and the channel center frequency.</p> | | |

Table 13 Interference Threshold values, Master or Client incorporating In-Service Monitoring

| Maximum Transmit Power | Value (See Notes 1, 2, and 3) |
|---|----------------------------------|
| EIRP ≥ 200 milliwatt | -64 dBm |
| EIRP < 200 milliwatt and power spectral density < 10 dBm/MHz | -62 dBm |
| EIRP < 200 milliwatt that do not meet the power spectral density requirement | -64 dBm |
| <p>Note 1: This is the level at the input of the receiver assuming a 0 dBi receive antenna.</p> <p>Note 2: Throughout these test procedures an additional 1 dB has been added to the amplitude of the test transmission waveforms to account for variations in measurement equipment. This will ensure that the test signal is at or above the detection threshold level to trigger a DFS response.</p> <p>Note3: EIRP is based on the highest antenna gain. For MIMO devices refer to KDB Publication 662911 D01.</p> | |

Table 14 DFS Response Requirement Values

| Parameter | Value |
|--|---|
| Non-occupancy period | Minimum 30 minutes |
| Channel Availability Check Time | 60 seconds |
| Channel Move Time | 10 seconds See Note 1. |
| Channel Closing Transmission Time | 200 milliseconds + an aggregate of 60 milliseconds over remaining 10 second period. See Notes 1 and 2 |
| U-NII Detection Bandwidth | Minimum 100% of the U-NII 99% transmission power bandwidth. See Note 3. |
| <p>Note 1: Channel Move Time and the Channel Closing Transmission Time should be performed with Radar Type 0. The measurement timing begins at the end of the Radar Type 0 burst.</p> <p>Note 2: The Channel Closing Transmission Time is comprised of 200 milliseconds starting at the beginning of the Channel Move Time plus any additional intermittent control signals required to facilitate a Channel move (an aggregate of 60 milliseconds) during the remainder of the 10 second period. The aggregate duration of control signals will not count quiet periods in between transmissions.</p> <p>Note 3: During the U-NII Detection Bandwidth detection test, radar type 0 should be used. For each frequency step the minimum percentage of detection is 90 percent. Measurements are performed with no data traffic.</p> | |

Table 15 Short Pulse Radar Test Waveforms

| Radar Type | Pulse Width (μsec) | PRI (μsec) | Number of Pulses | Minimum Percentage of Successful Detection | Minimum Number of Trials |
|---|--------------------|---|---|--|--------------------------|
| 0 | 1 | 1428 | 18 | See Note 1 | See Note 1 |
| 1 | 1 | Test A: 15 unique PRI values randomly selected from the list of 23 PRI values in Table 5a | Roundup: $\{(1/360) \times (19 \times 10^6 \text{PRI}_{\mu\text{sec}})\}$ | 60% | 30 |
| | | Test B: 15 unique PRI values randomly selected within the range of 518-3066 μsec, with a minimum increment of 1 μsec, excluding PRI values Selected in Test A | | | |
| 2 | 1-5 | 150-230 | 23-29 | 60% | 30 |
| 3 | 6-10 | 200-500 | 16-18 | 60% | 30 |
| 4 | 11-20 | 200-500 | 12-16 | 60% | 30 |
| Aggregate (Radar Types 1-4) | | | | 80% | 120 |
| Note 1: Short Pulse Radar Type 0 should be used for the detection bandwidth test, channel move time, and channel closing time tests. | | | | | |

Table 16 Long Pulse Radar Test Waveform

| Radar Type | Pulse Width (μsec) | Chirp Width (MHz) | PRI (μsec) | Number of Pulses per Burst | Number of Bursts | Minimum Percentage of Successful Detection | Minimum Number of Trials |
|------------|--------------------|-------------------|------------|----------------------------|------------------|--|--------------------------|
| 5 | 50-100 | 5-20 | 1000-2000 | 1-3 | 8-20 | 80% | 30 |

Table 17 Frequency Hopping Radar Test Waveform

| Radar Type | Pulse Width (μsec) | PRI (μsec) | Pulses per Hop | Hopping Rate (kHz) | Hopping Sequence Length (msec) | Minimum Percentage of Successful Detection | Minimum Number of Trials |
|------------|--------------------|------------|----------------|--------------------|--------------------------------|--|--------------------------|
| 6 | 1 | 333 | 9 | 0.333 | 300 | 70% | 30 |

6.2. TEST PROCEDURE

The EUT Operates over the 5250-5350MHz and 5470-5725 MHz range and it is a Client Device without Radar Detection.

The radar detection threshold, lower antenna gain is the parameter of interference radar DFS detection threshold, the required conducted threshold at the antenna port is the $-62\text{dBm}+0\text{dBi}+1\text{dB}=-61\text{dBm}$.

The R&S SMBV100A vector signal generator with option K350 is used to generate the pulse during test.

The Client device is connected to the Master device on the Channel selected to test. The program iPerf is used to set up a connection between the Client and the Master Device with proper duty cycle.

The Spectrum analyzer is used to monitor the DFS radar pulse and the EUT transmission with zero span function at the selected Channel. The spectrum analyzer is set to peak detection, and max hold.

WLAN traffic load is verified before the pulse is injected.

Channel Move time

The test software controls the spectrum analyzer to start monitoring the EUT transmission, and at $T_0=2\text{sec}$, the pulse is injected. The time the pulse stop is marked as T_1 , The time when no transmission is detected is marked as T_3 . T_3-T_1 is calculated as Channel move time.

Non-Occupancy Period

The test software controls the spectrum analyzer to start monitoring the EUT transmission, and at $T_0=10\text{sec}$, the pulse is injected. T_2 is the channel move time stop moment; the software controls the spectrum to monitor for 1800 seconds. The plot is recorded in report.

6.3. TEST DATA

RADAR WAVEFORM:

Type 0

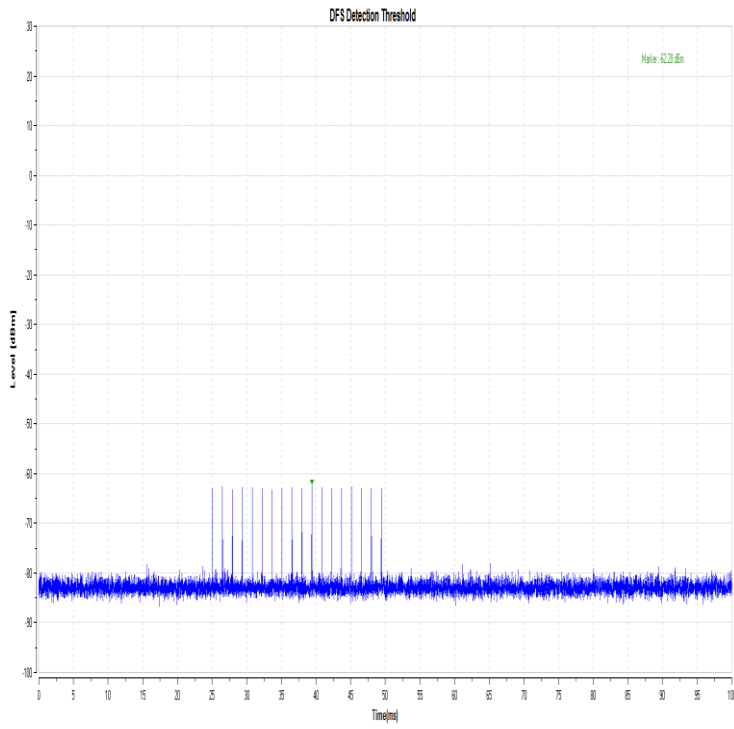
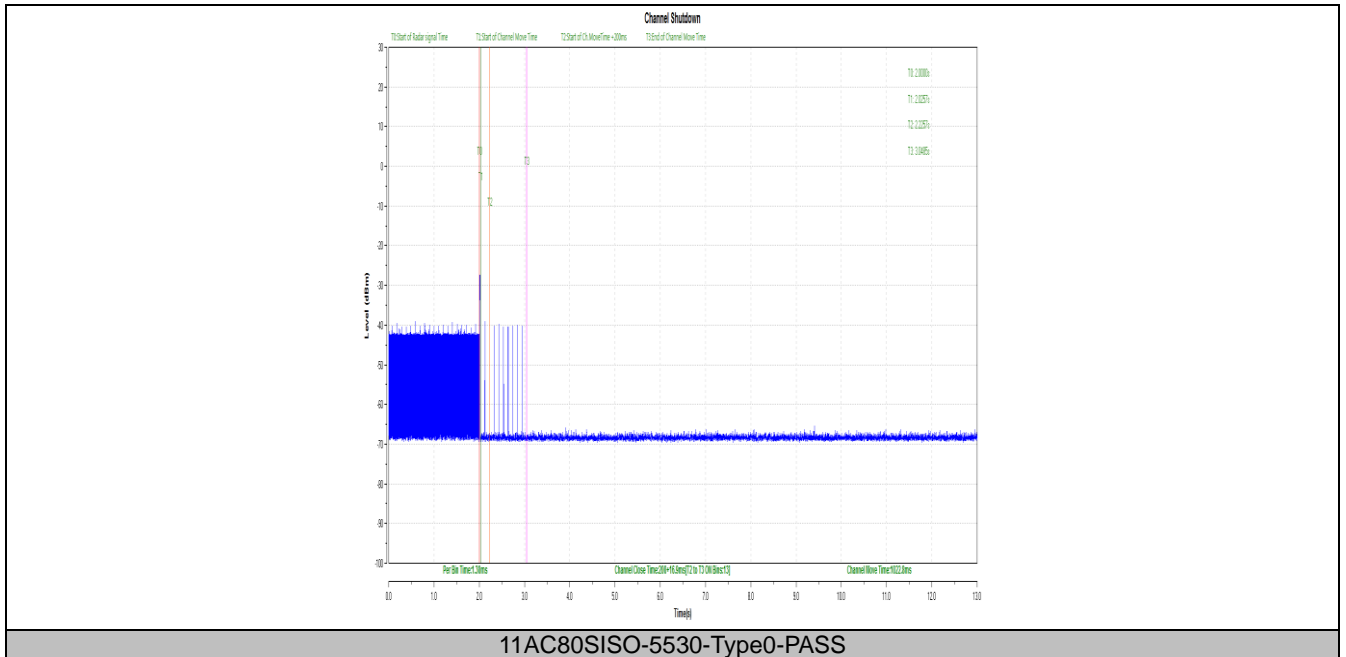

Table 18 Channel Move Time and Channel Closing Test Data 802.11ac VHT80

| CHANNEL FREQUENCY (MHz) | Channel Move Time(sec) | Limit(sec) | results |
|-------------------------|------------------------|------------|---------|
| 5530 | 0.952 | 10 | Pass |



11AC80SISO-5530-Type0-PASS

Non-Occupancy Period Test

| TestMode | Frequency[MHz] | Result | Limit[s] | Verdict |
|------------|----------------|----------------|----------|---------|
| 11AC80SISO | 5530 | see test graph | ≥1800 | PASS |

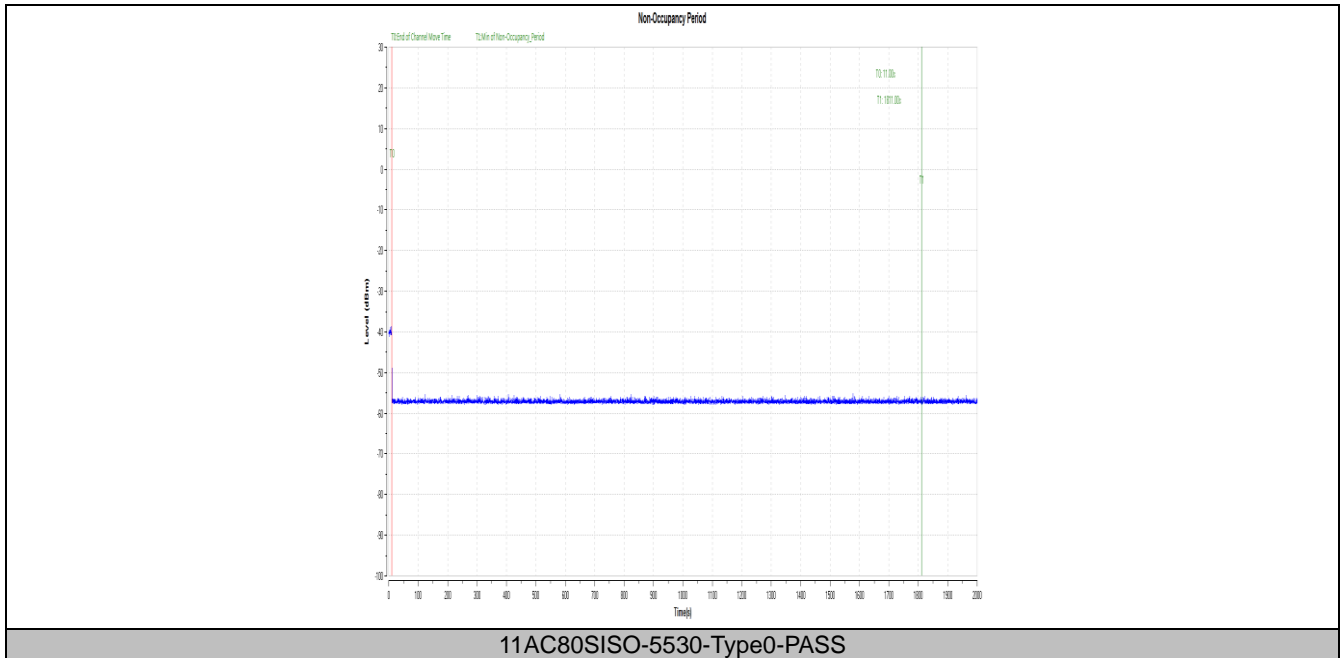

END OF REPORT