

BOM_VAR_Name \${VAR_NAME}	
BOM_VAR_Description \${VAR_DESC}	
Company	<b>vivo</b>
PlatForm MT6769V/CT	Project PD2103BF/DF
Sheet Name MT6769_POWER1	
Size A1	
Rev -0	
Drawn By DingSong	Page 1 of 27
	17/06/2021:11:54

0000164  
V009  
MT6769

MT6769-SBS

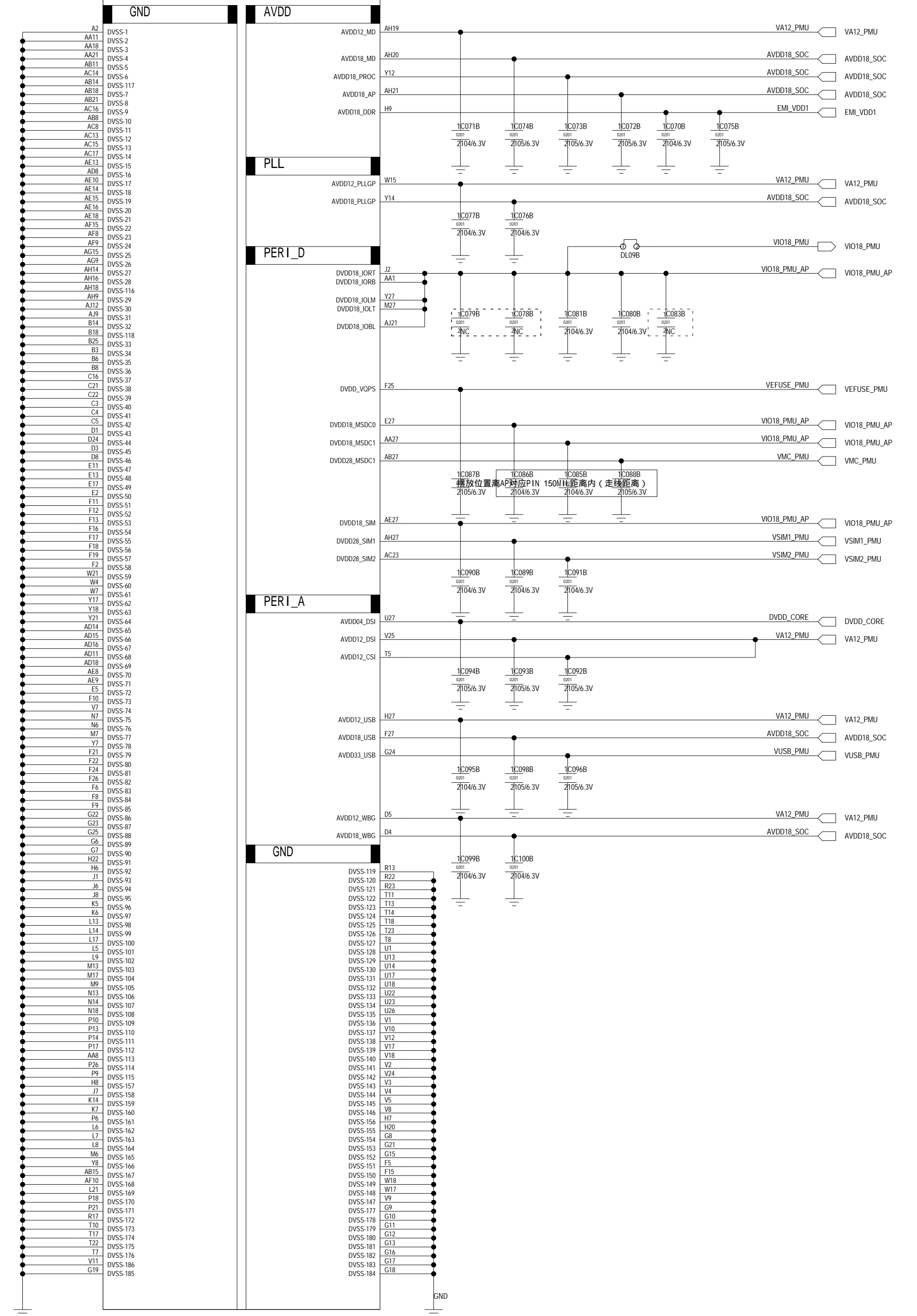

BOM\_VAR\_Name  
\${VAR\_NAME}

BOM\_VAR\_Description  
\${VAR\_DESC}

Company: **vivo**

Platform: MT6769V/CT      Project: PD2103BF/DF

Sheet Name: MT6769\_POWER2      Size: A1  
Rev: -0

Drawn By: DingSong      Page: 2 of 27      17/06/2021:11:54



12 11 10 9 8 7 6 5 4 3 2 1

H  
G  
F  
E  
D  
C  
B  
A

H  
G  
F  
E  
D  
C  
B  
A

080764  
U909  
MT6769  
**MT6769-SBS** C of G

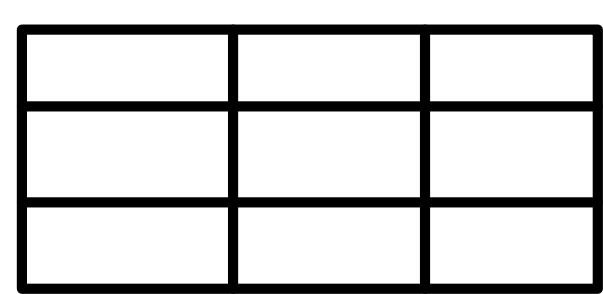
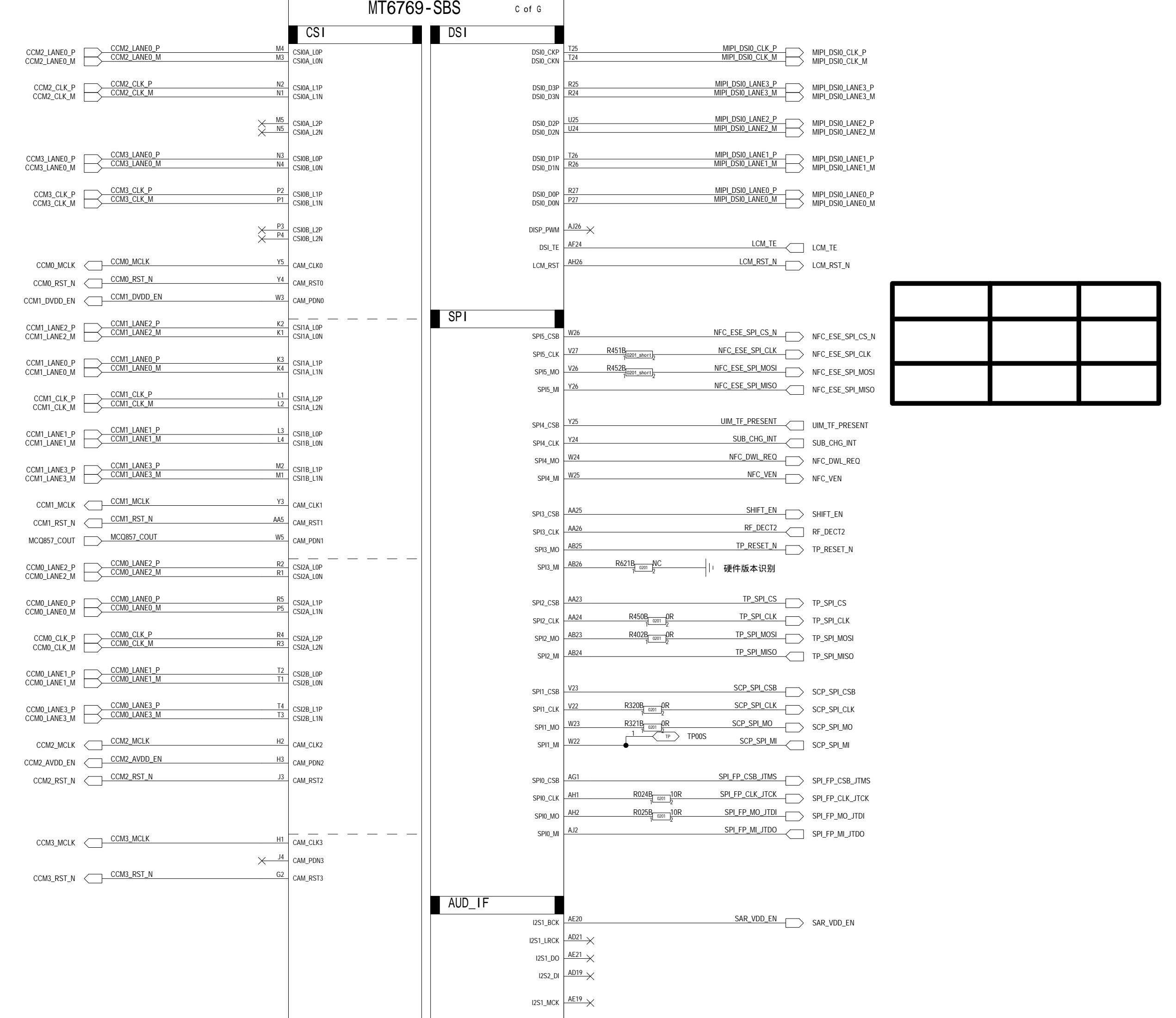

BOM_VAR_Name \${VAR_NAME}	
BOM_VAR_Description \${VAR_DESC}	
Company <b>vivo</b>	
PlatForm MT6769V/CT	Project PD2103BF/DF
Sheet Name MT6769_CNTRL_MIPI2	
Size A1	
Rev -0	
Drawn By DingSong	Page 4 of 27
17/06/2021:11:55	

12 11 10 9 8 7 6 5 4 3 2 1

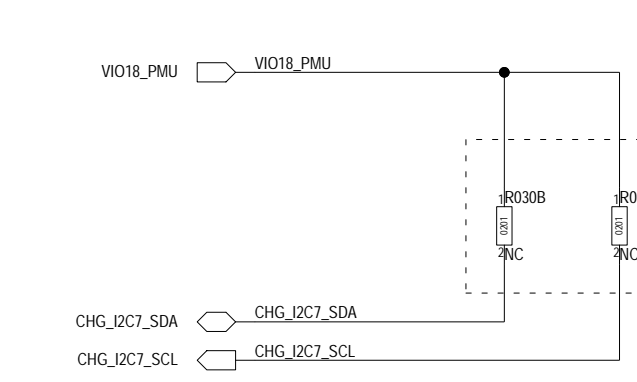
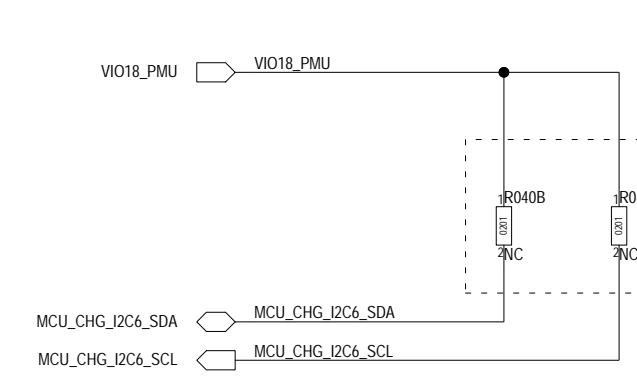
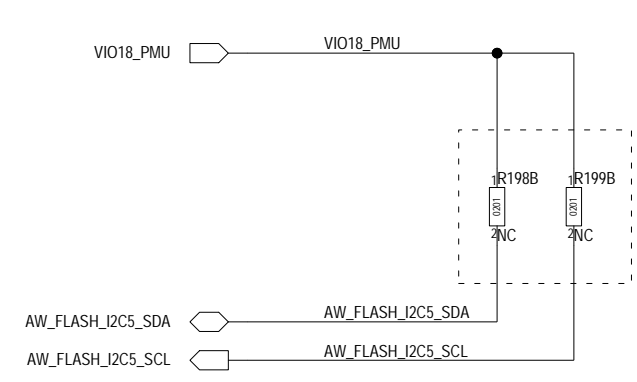
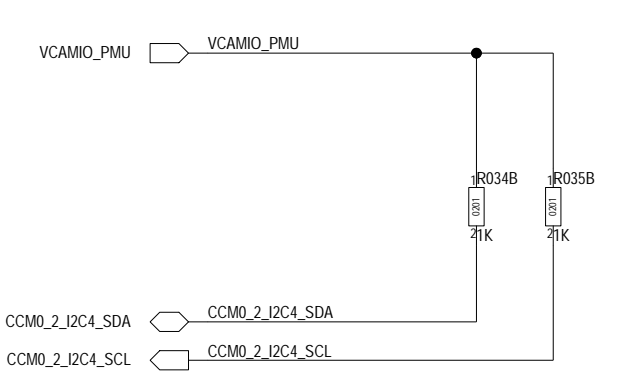
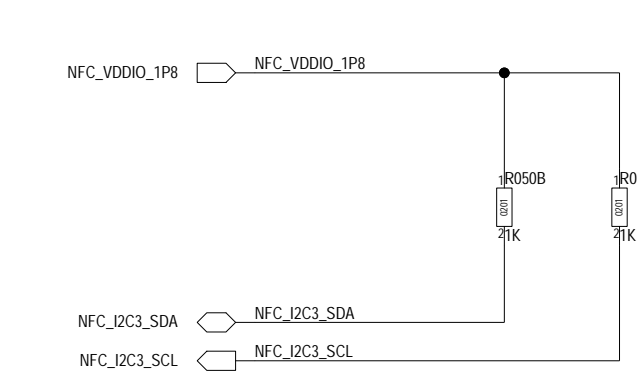
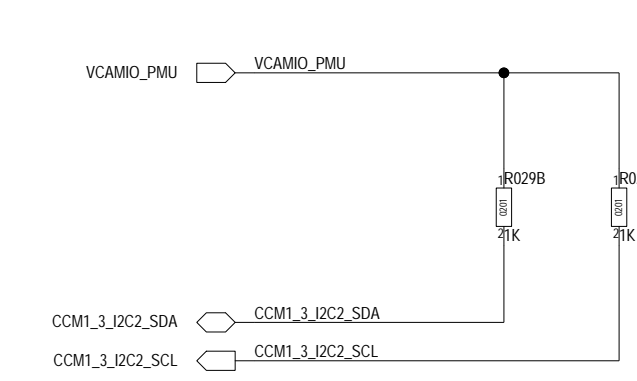
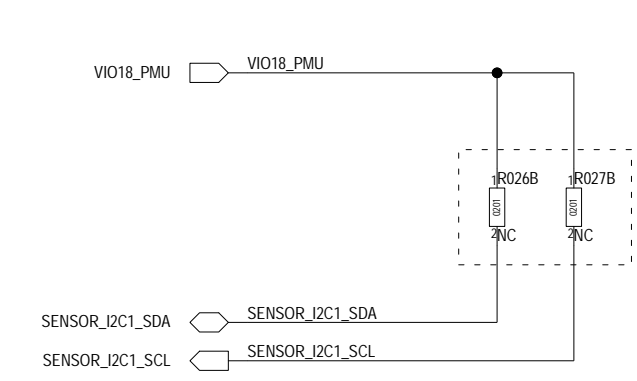
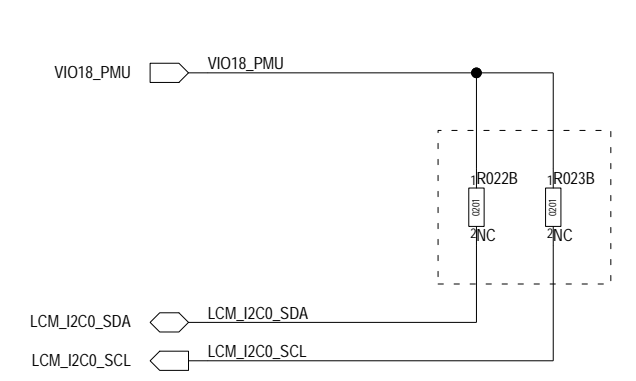
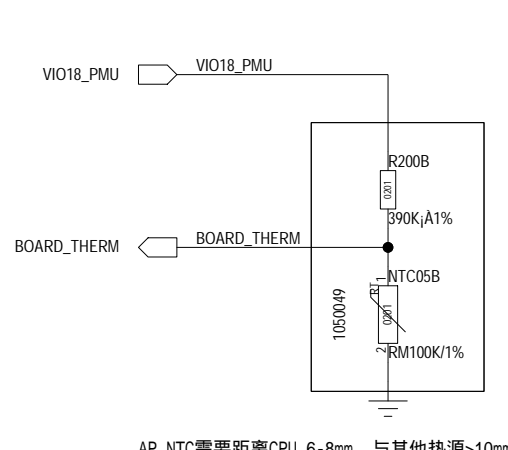
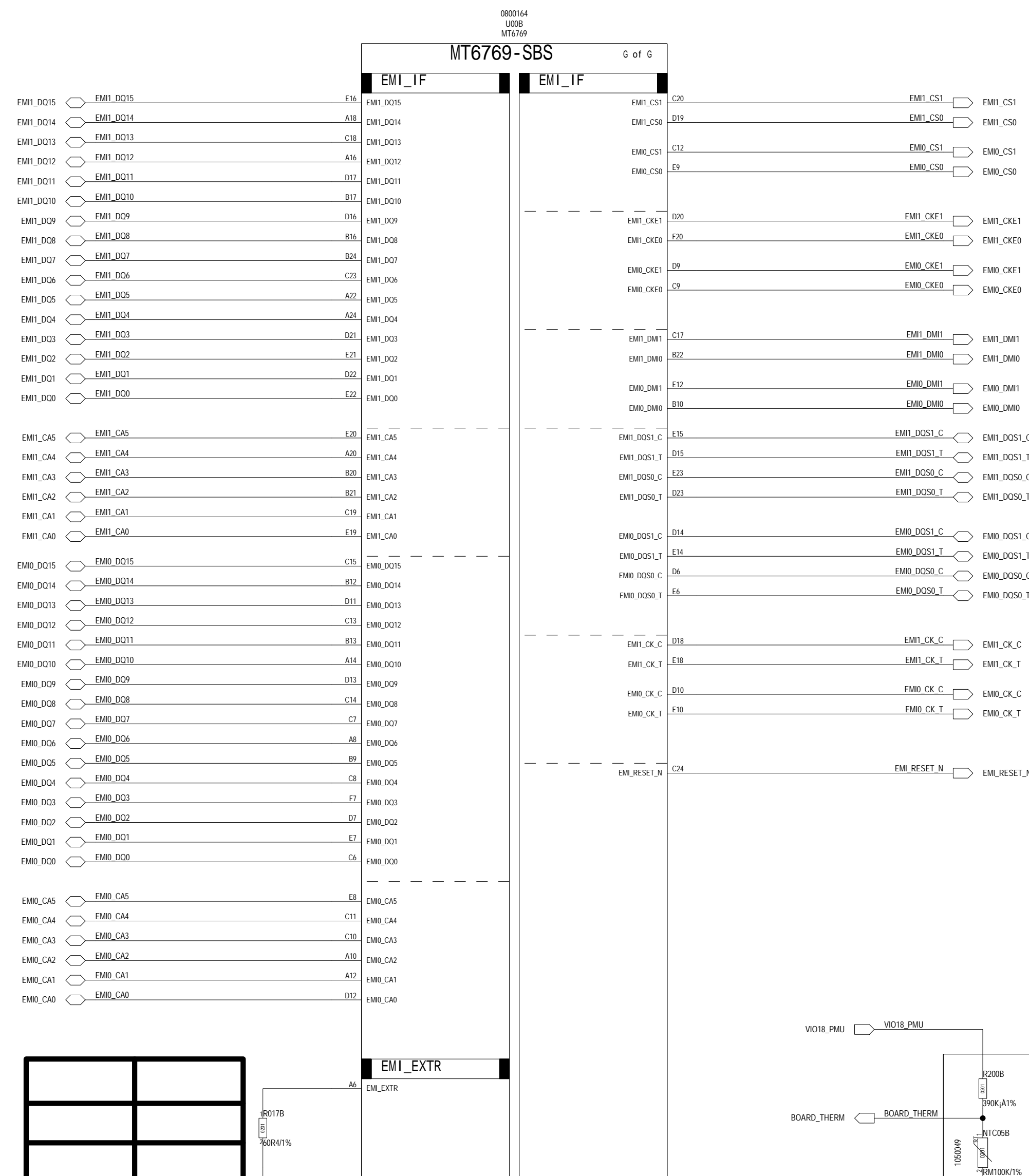
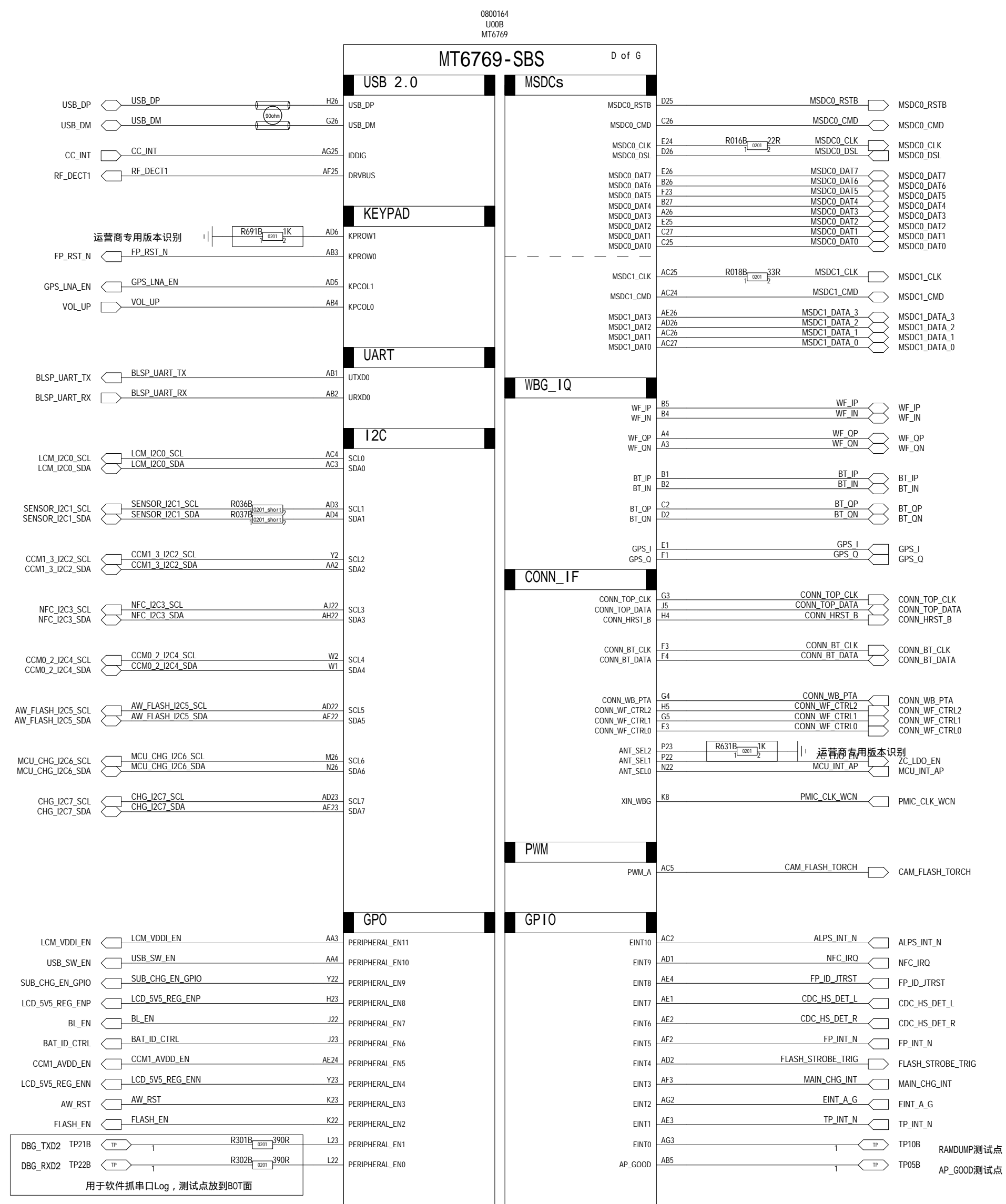

Company <b>vivo</b>	
PlatForm MT6769V/CT	Project PD2103BF/DF
Sheet Name MT6769_GPIO_EMI	
Drawn By DingSong	Page 5 of 27
Date 17/06/2021-11:55	
Size A1 Rev -0	

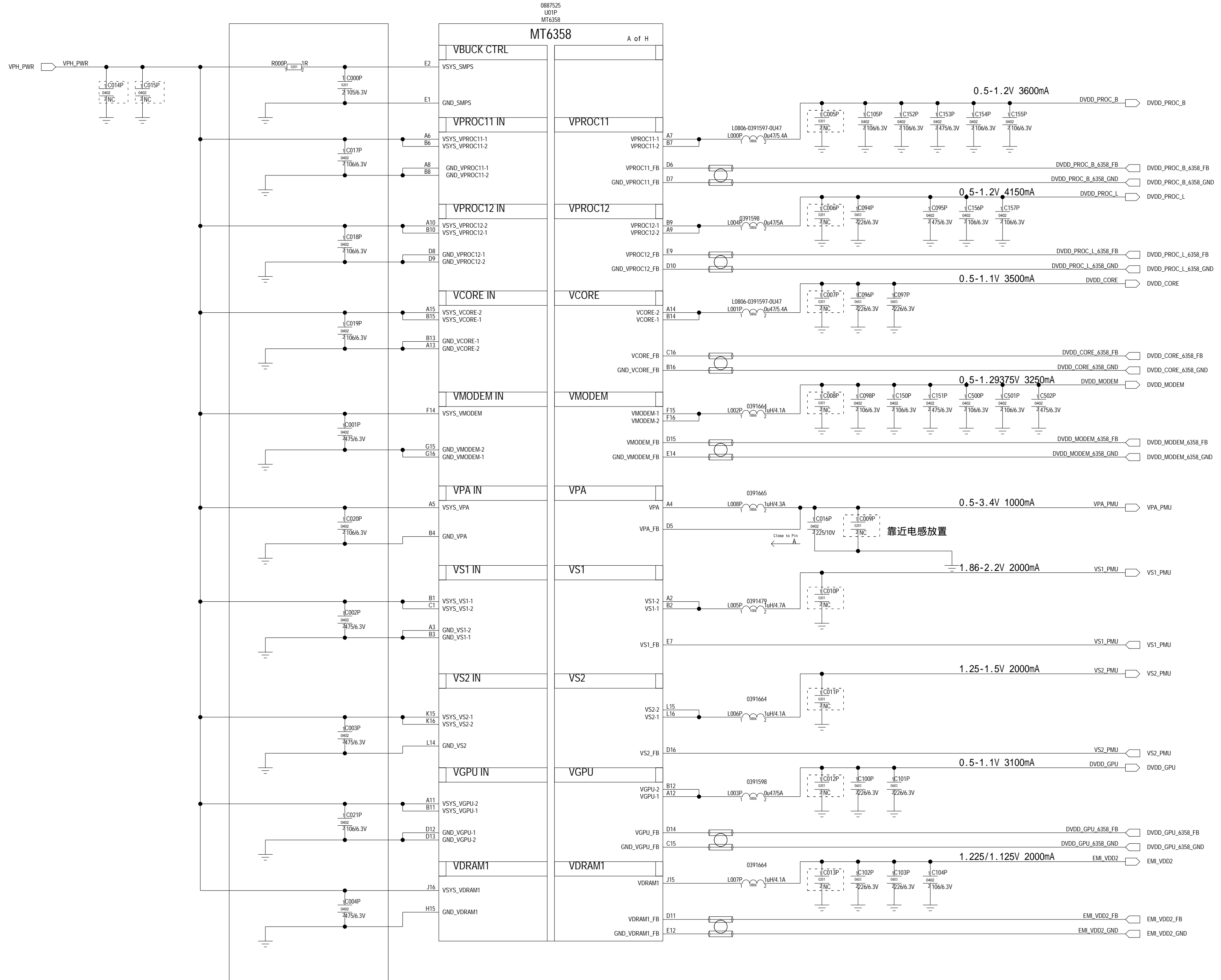

BOM\_VAR\_Name  
 \${VAR\_NAME}  
 BOM\_VAR\_Description  
 \${VAR\_DESC}

Company		<b>vivo</b>	
PlatForm	MT6769V/CT	Project	PD2103BF/DF
Sheet Name	MT6358_DCDC		Size A1
			Rev -0
Drawn By	DingSong	Page	6 of 27
			17/06/2021:11:55

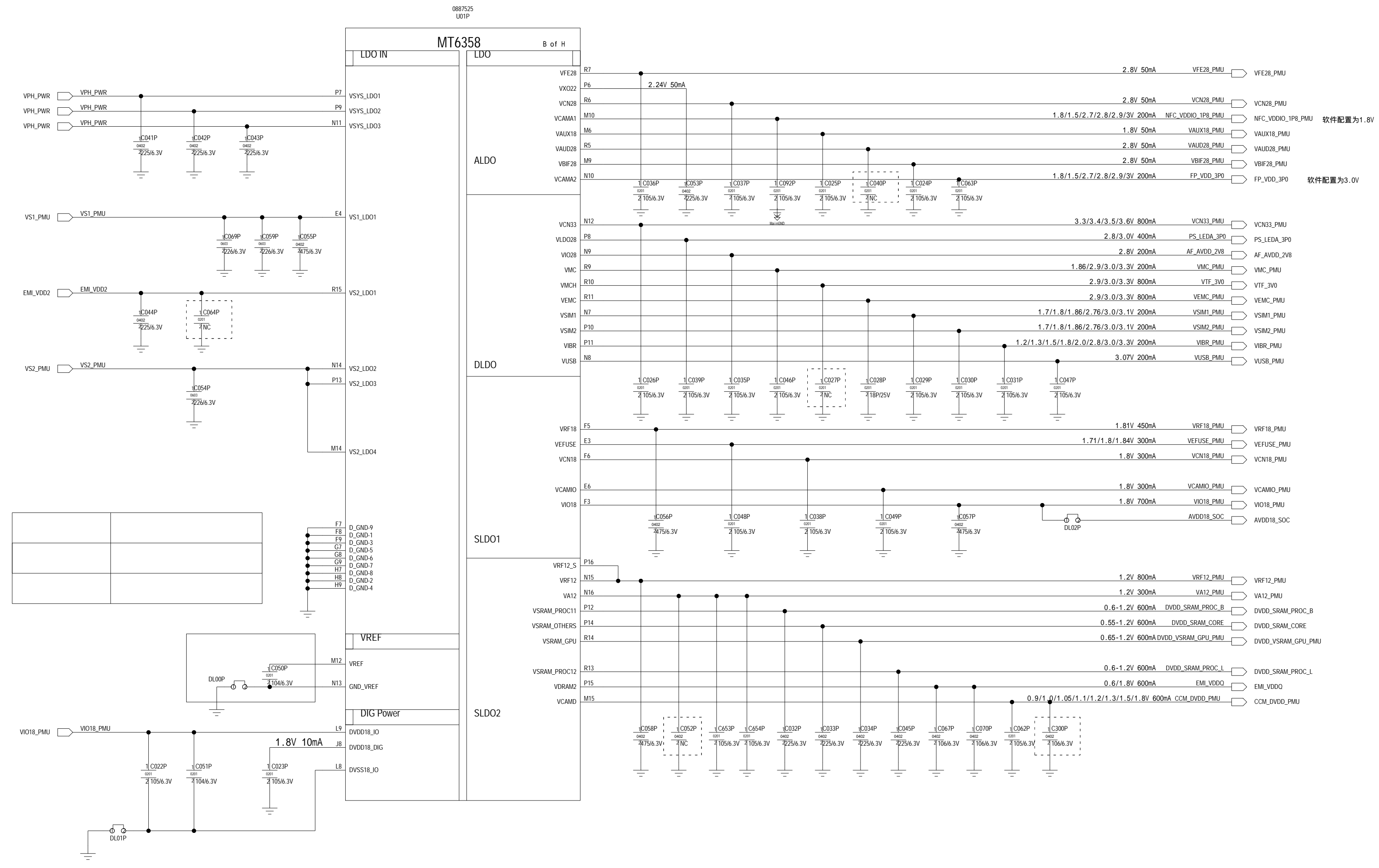

BOM\_VAR\_Name  
 \${VAR\_NAME}  
 BOM\_VAR\_Description  
 \${VAR\_DESC}

Company  
**vivo**

Platform  
 MT6769V/CT

Project  
 PD2103BF/DF

Sheet Name  
 MT6358\_LDO

Size  
 A1

Rev  
 -0

Drawn By  
 DingSong

Page  
 7 of 27

17/06/2021:11:55

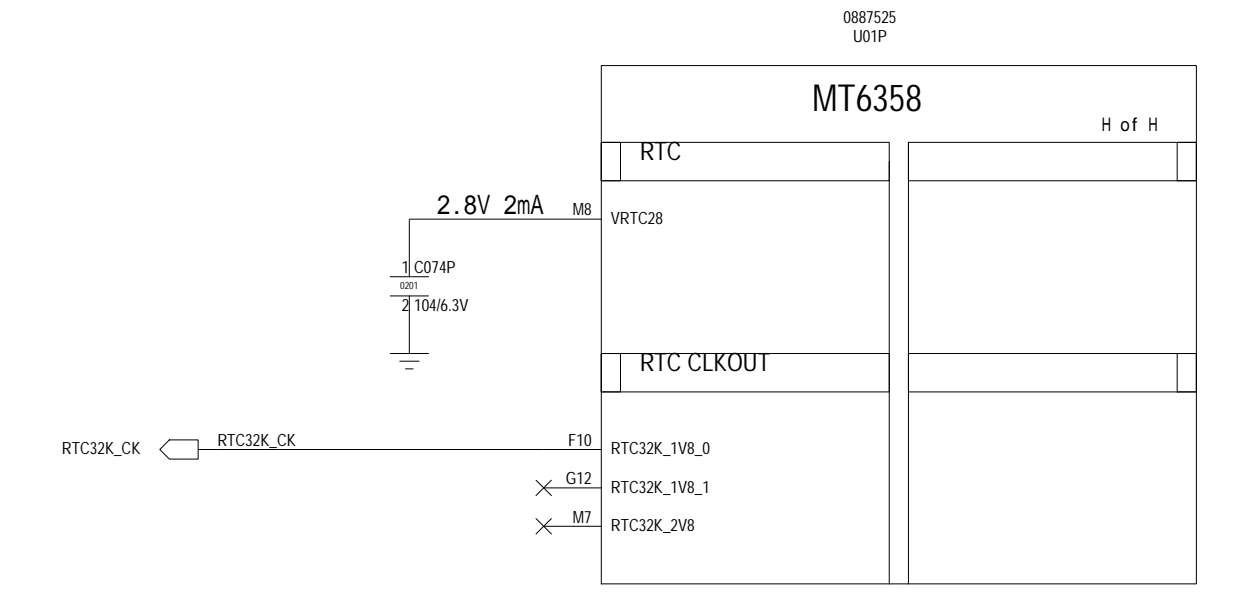
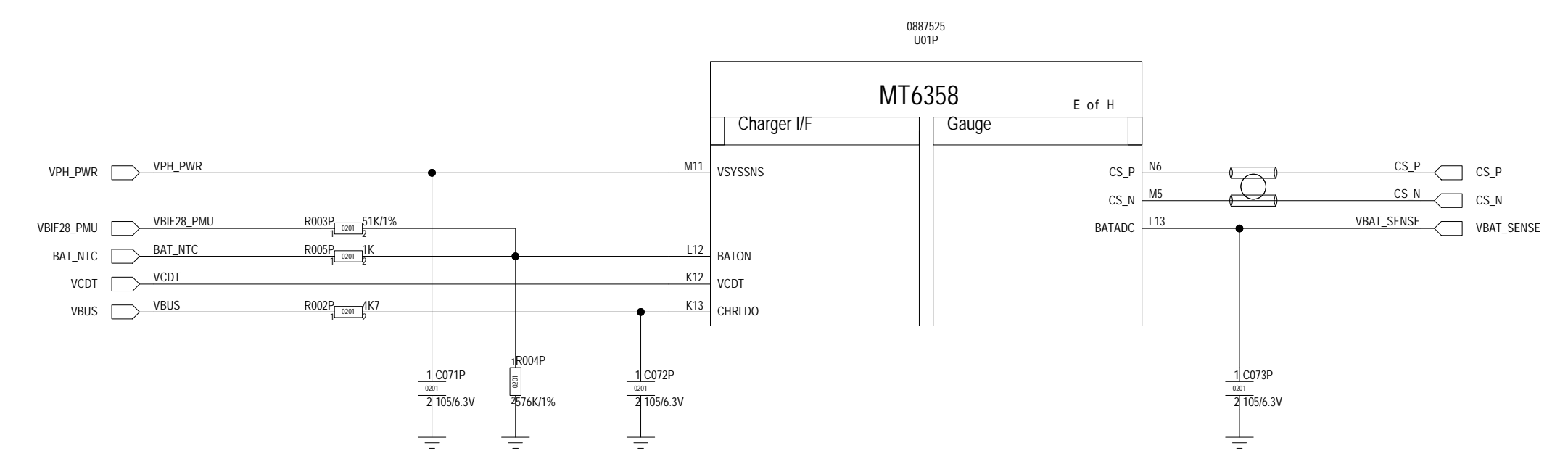
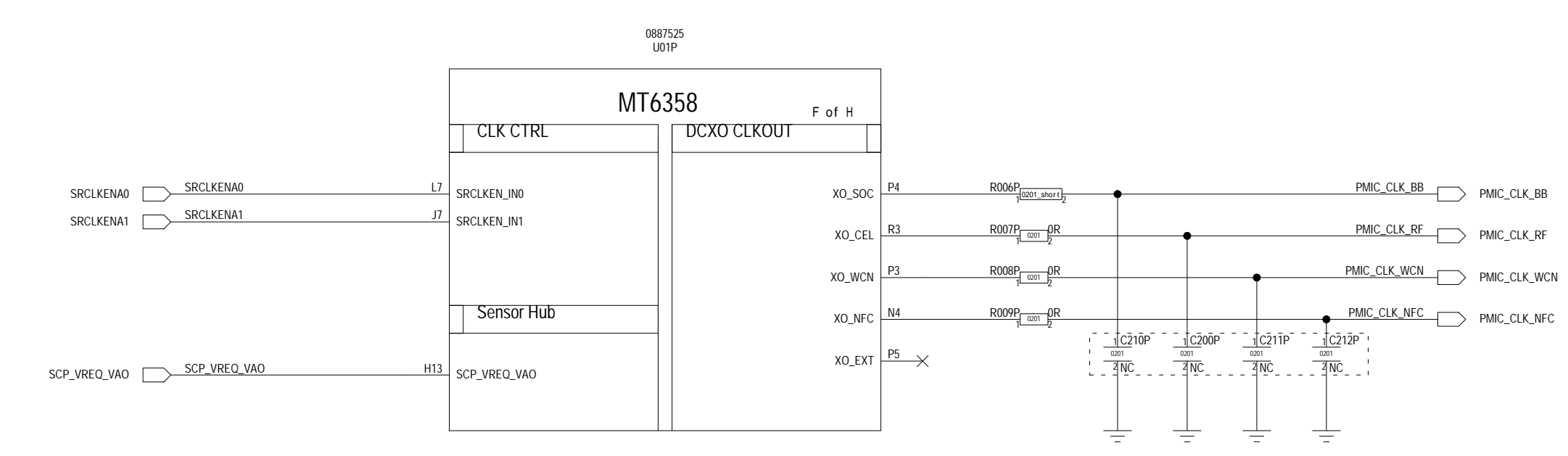
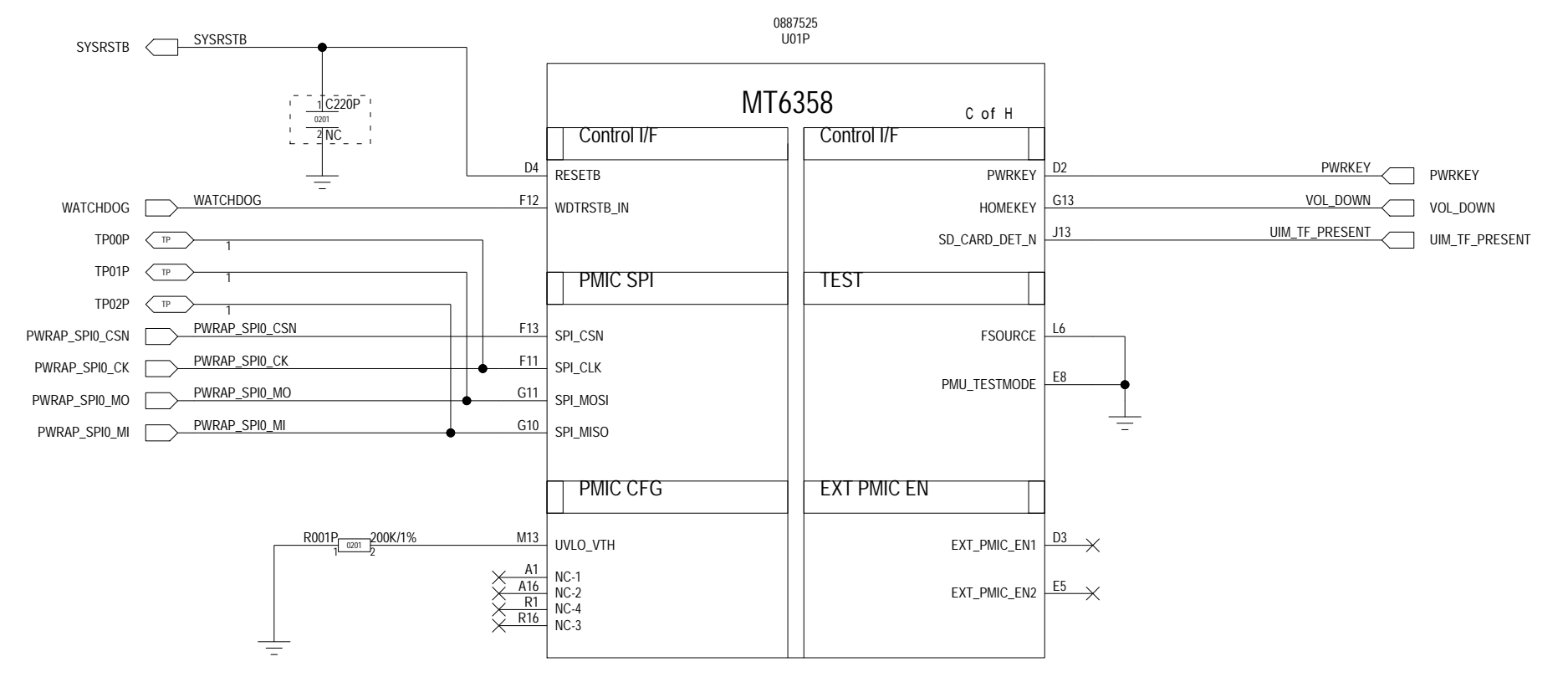

BOM\_VAR\_Name  
 \${VAR\_NAME}  
 BOM\_VAR\_Description  
 \${VAR\_DESC}

Company		<b>vivo</b>	
PlatForm	MT6769V/CT	Project	PD2103BF/DF
Sheet Name	MT6358_CTRL		Size A1
			Rev -0
Drawn By	DingSong	Page	8 of 27 17/06/2021:11:55



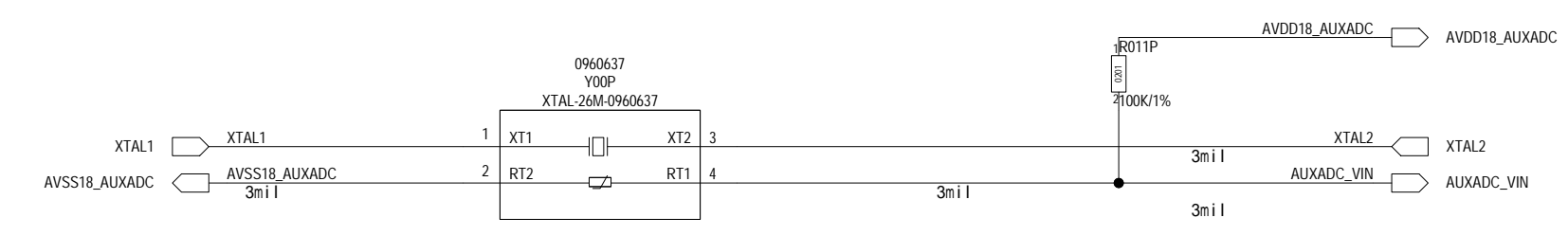
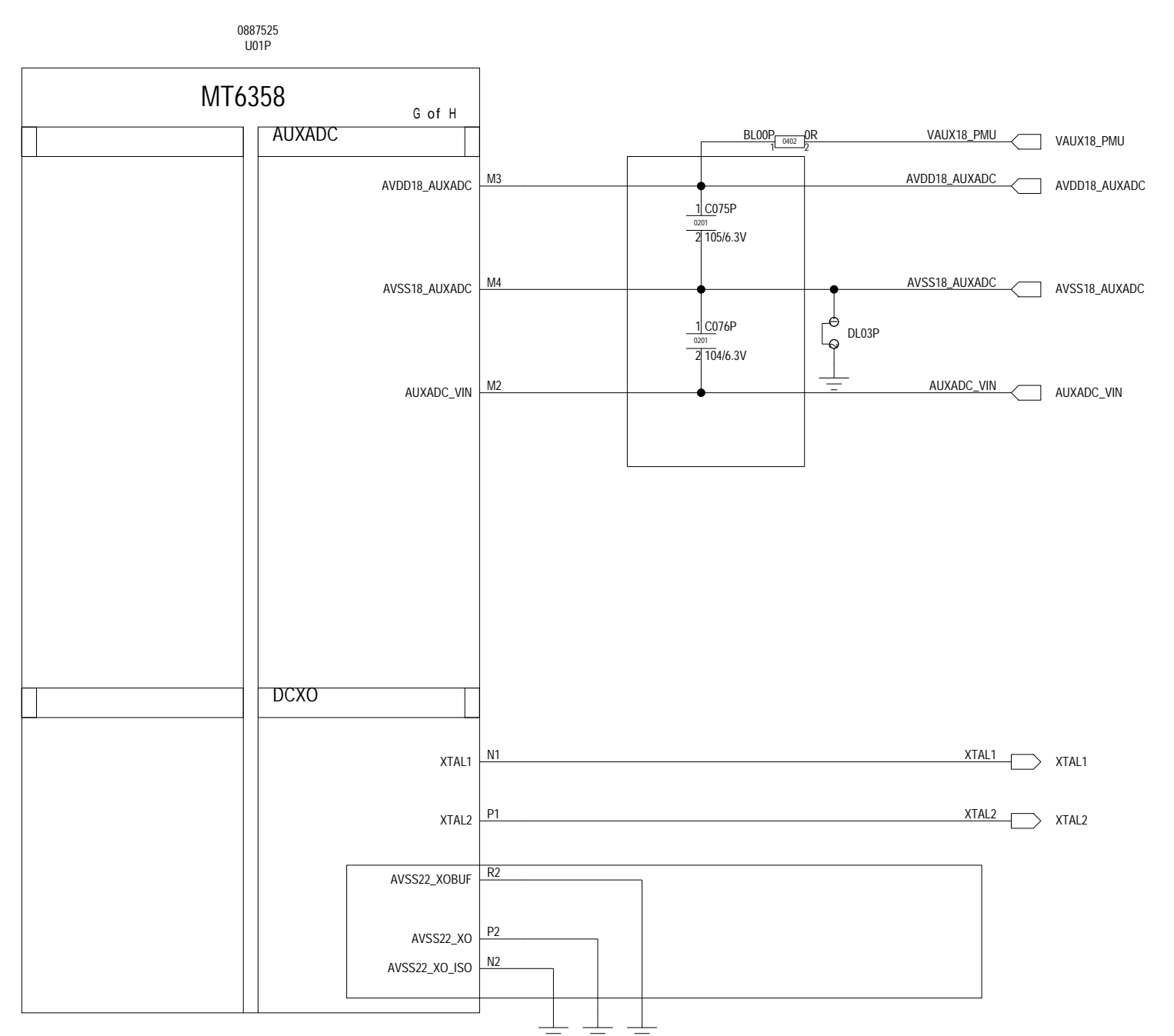
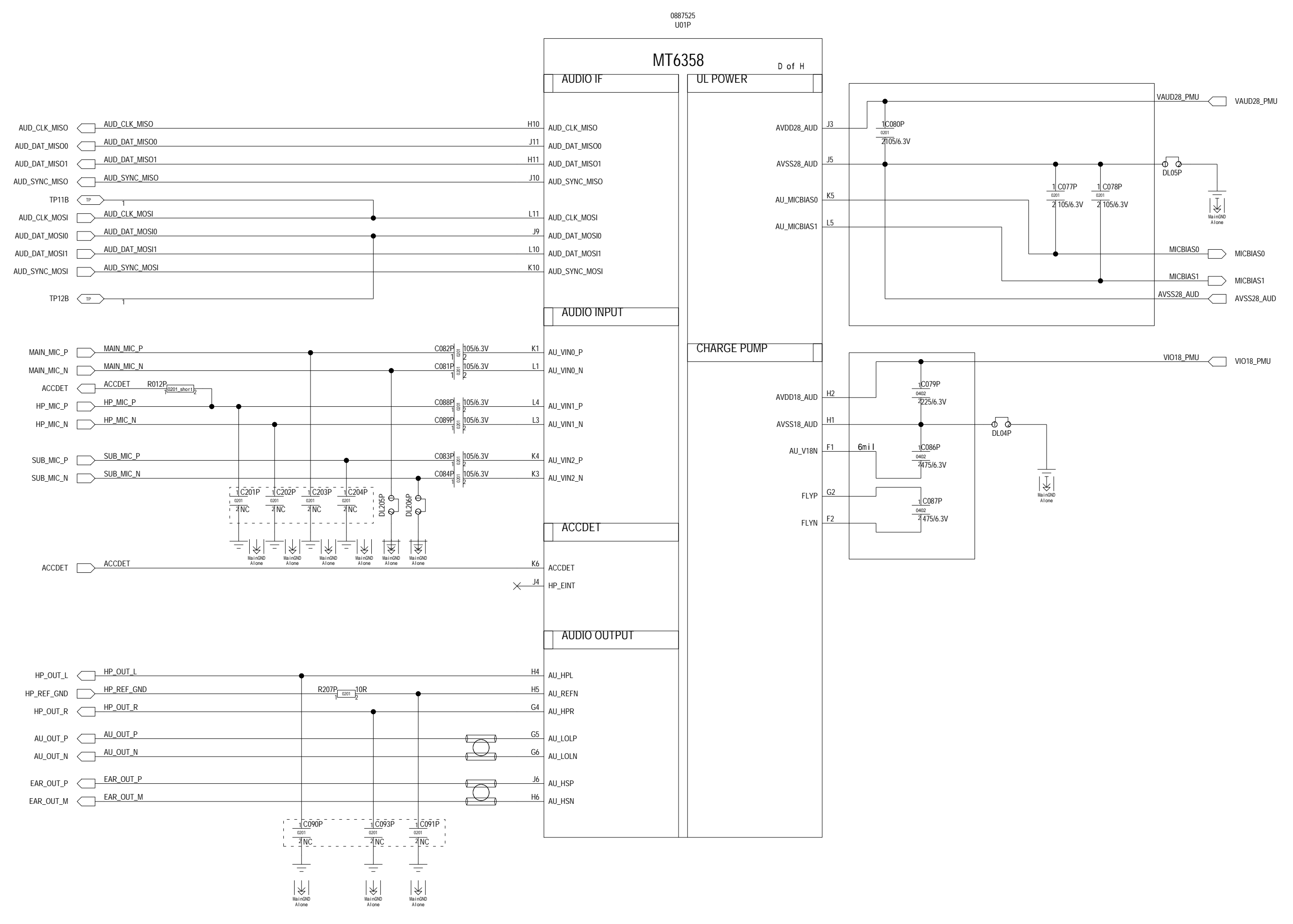

BOM\_VAR\_Name  
 \${VAR\_NAME}  
 BOM\_VAR\_Description  
 \${VAR\_DESC}

Company **vivo**

PlatForm **MT6769V/CT** Project **PD2103BF/DF**

Sheet Name **MT6358\_AUDIO** Size **A1**  
 Rev **-0**

Drawn By **DingSong** Page **9 of 27** 17/06/2021:11:56

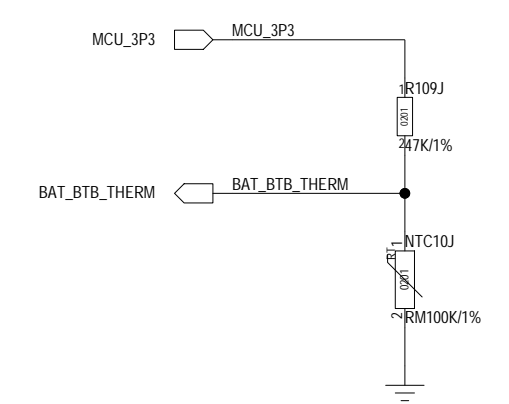
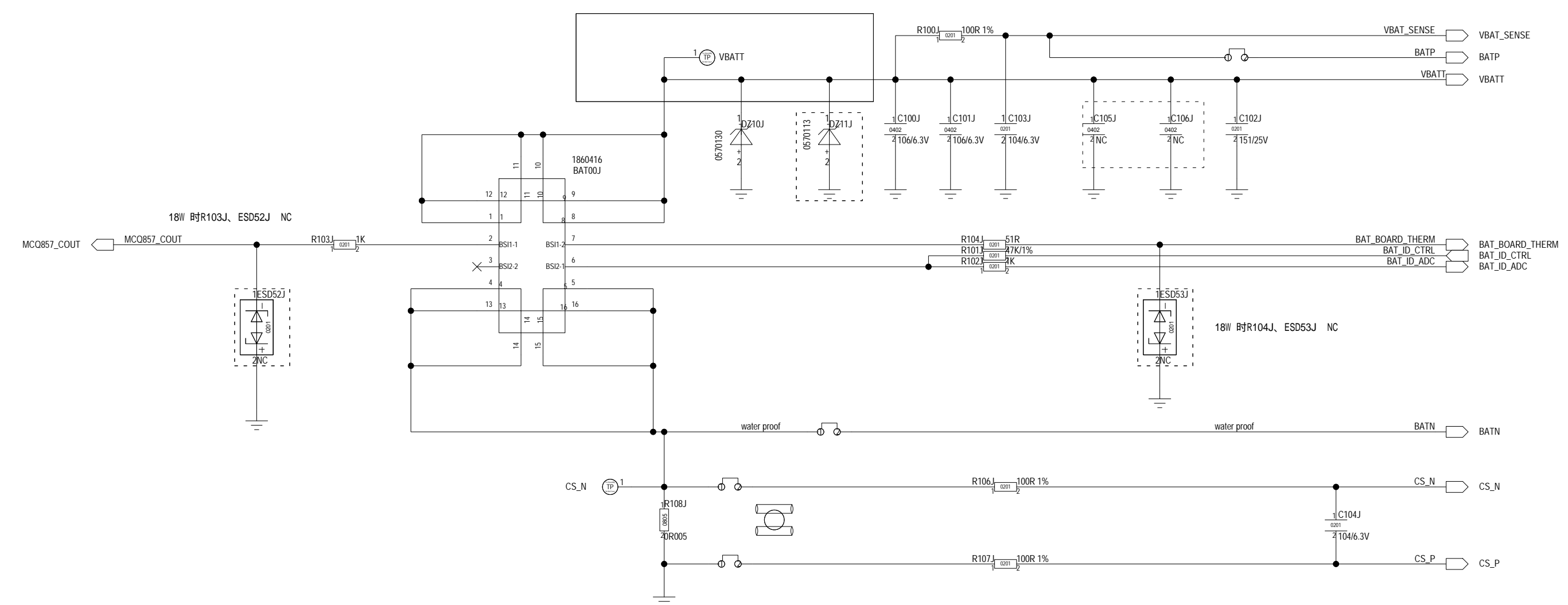
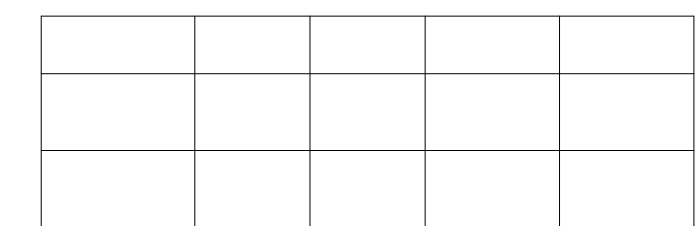
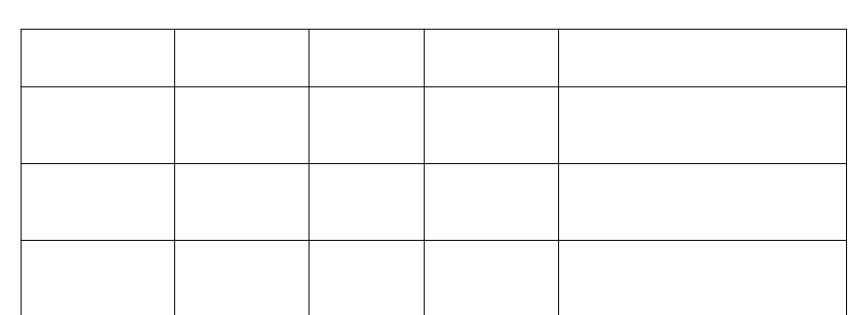
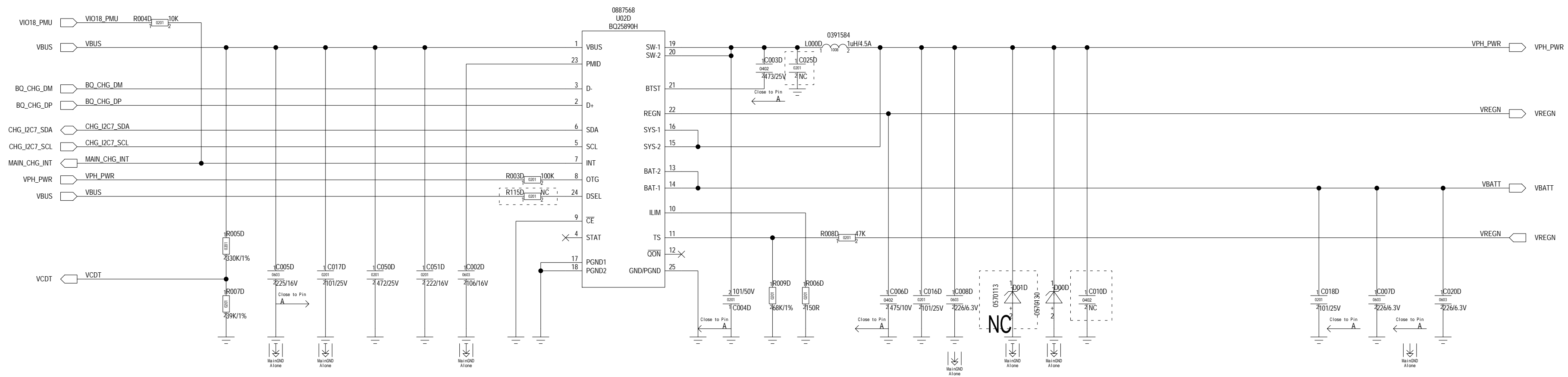

BOM_VAR_Name \${VAR_NAME}	
BOM_VAR_Description \${VAR_DESC}	
Company <b>vivo</b>	
PlatForm MT6769V/CT	Project PD2103BF/DF
Sheet Name CHARGE_VBAT	Size A1 Rev -0
Drawn By DingSong	Page 10 of 27 17/06/2021:11:56



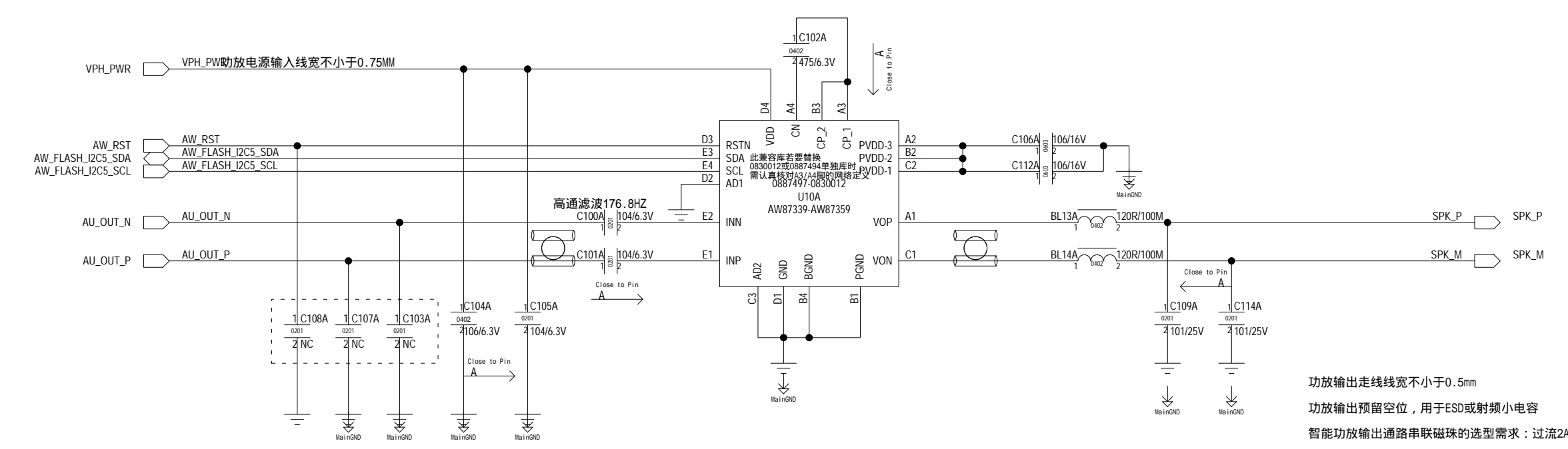
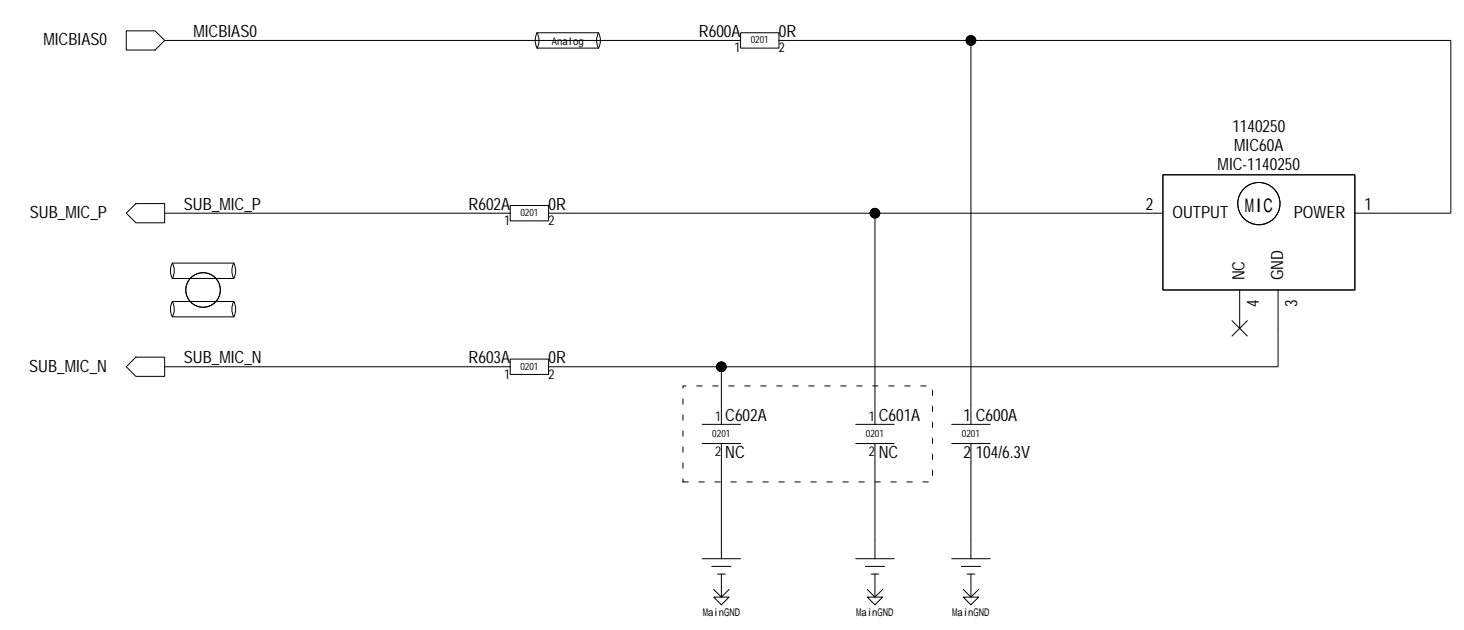
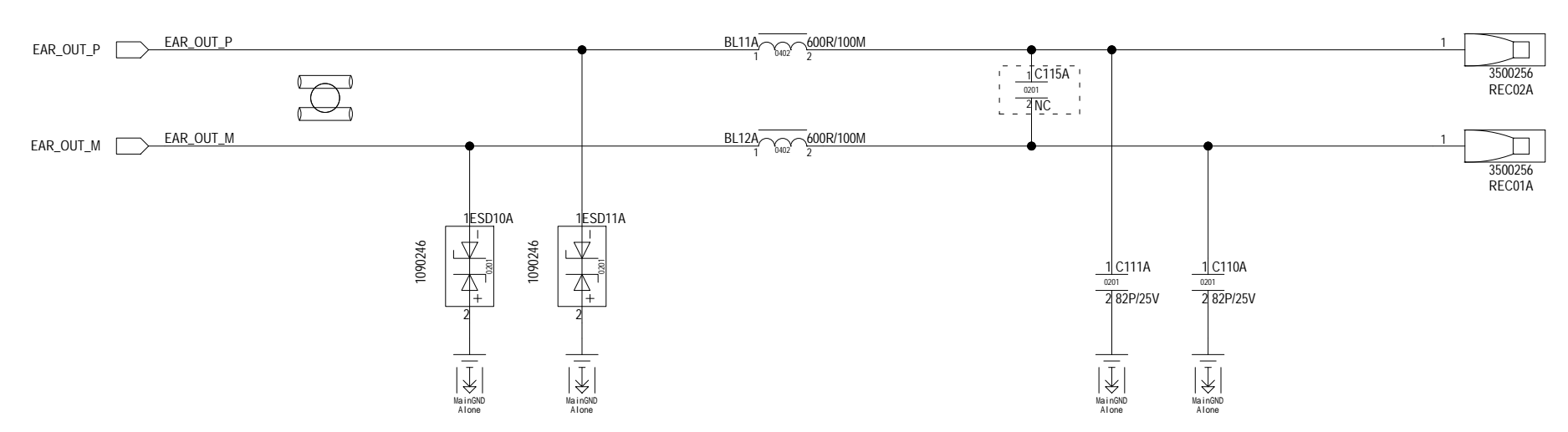

功放输出走线线宽不小于0.5mm  
 功放输出预留空位，用于ES0或射小电容  
 智能功放输出通路串联磁珠的选型需求：过流2A 低频用抗小且一致性好，不影响校准；推荐物料：0402磁珠（料号：0391644，120 /100M ±25% 2A）  
 功放模拟数字信号包地处理：12S(如有)，模拟输出等

BOM\_VAR\_Name  
 \${VAR\_NAME}  
 BOM\_VAR\_Description  
 \${VAR\_DESC}

Company		<b>vivo</b>	
PlatForm	MT6769V/CT	Project	PD2103BF/DF
Sheet Name	AUDIO	Size	A1
		Rev	-0
Drawn By	DingSong	Page	12 of 27
			17/06/2021:11:57

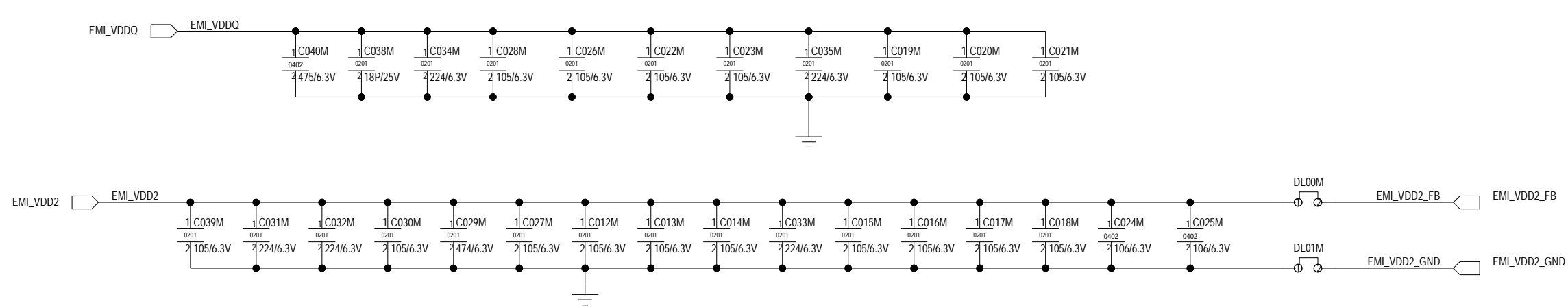
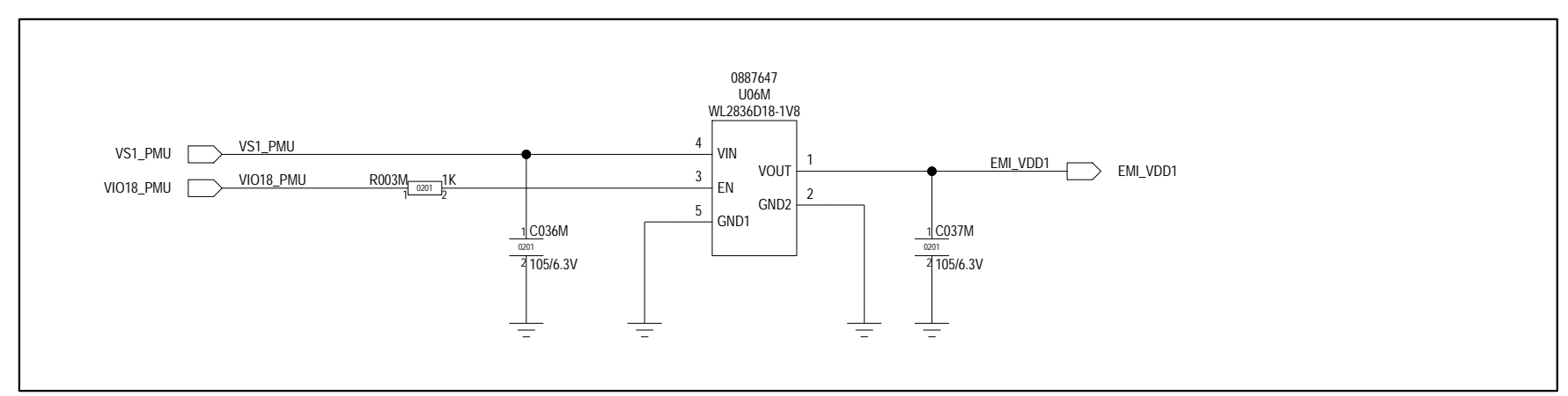
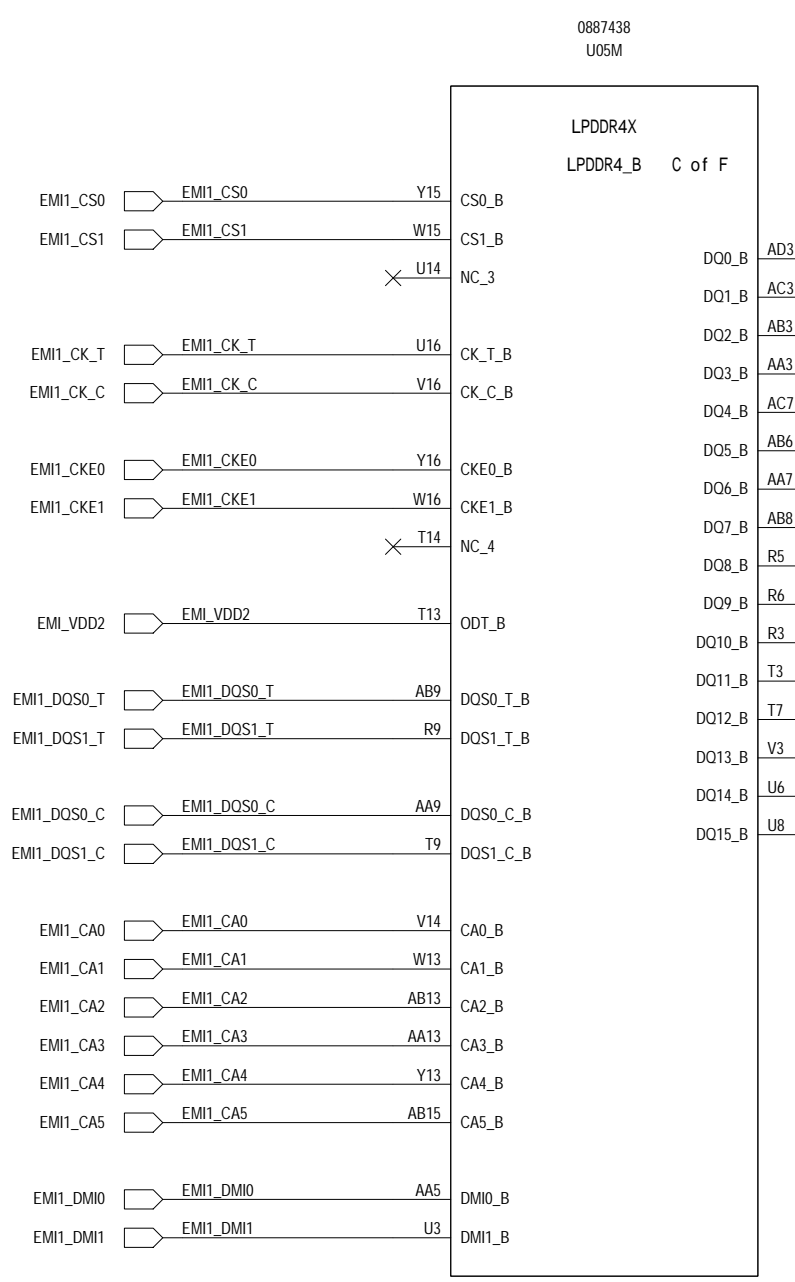
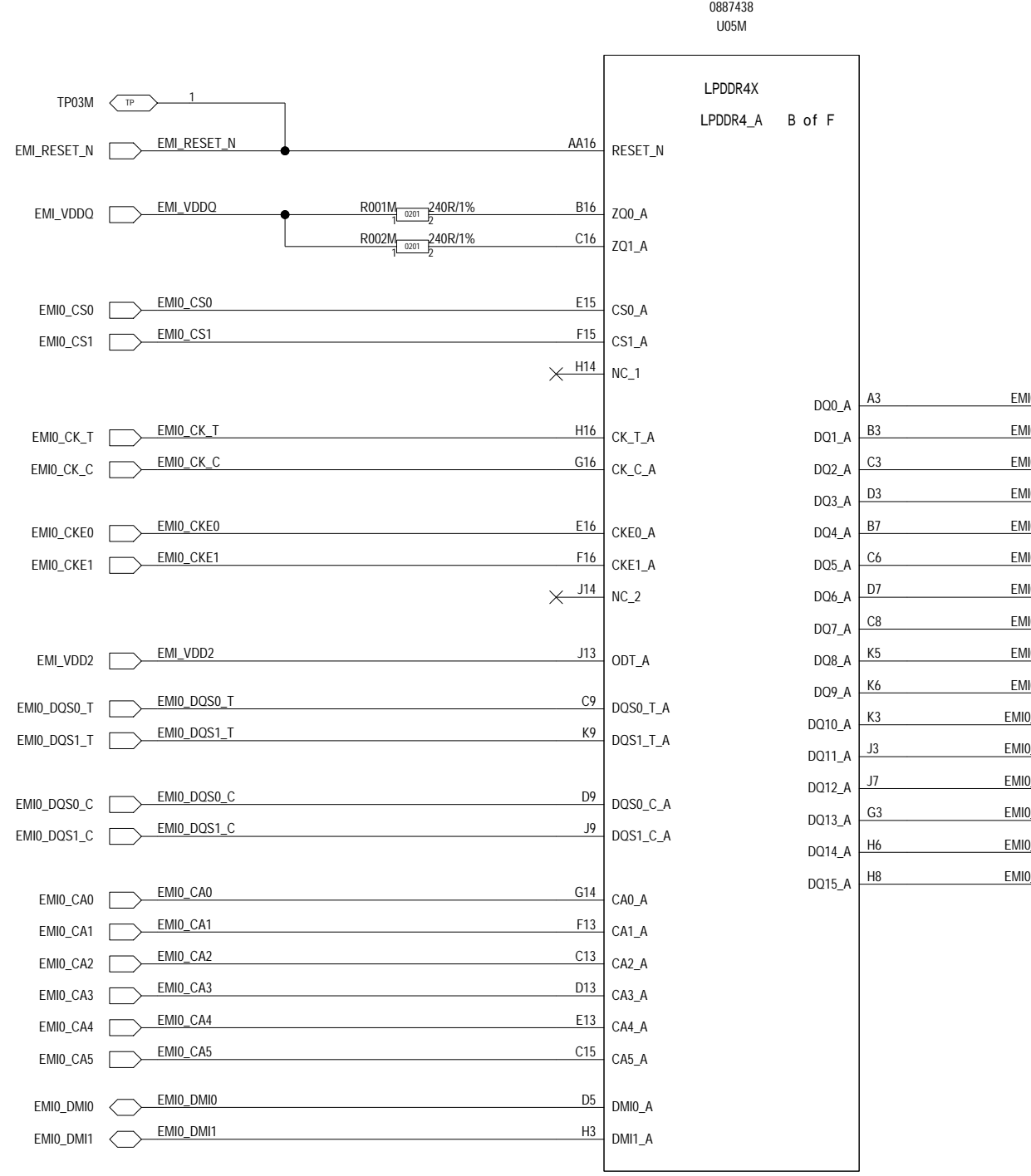
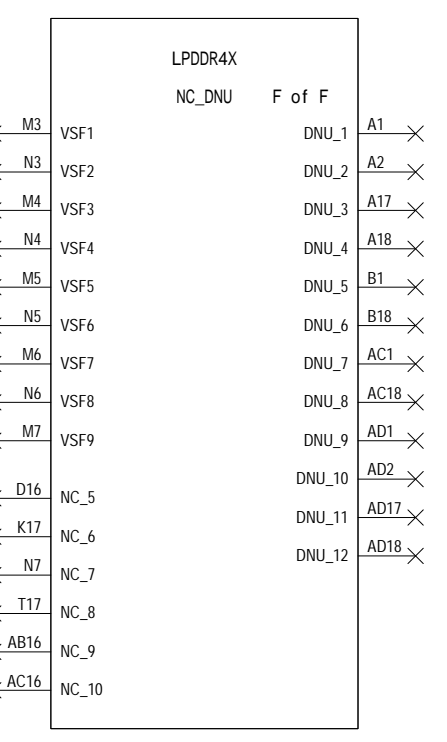
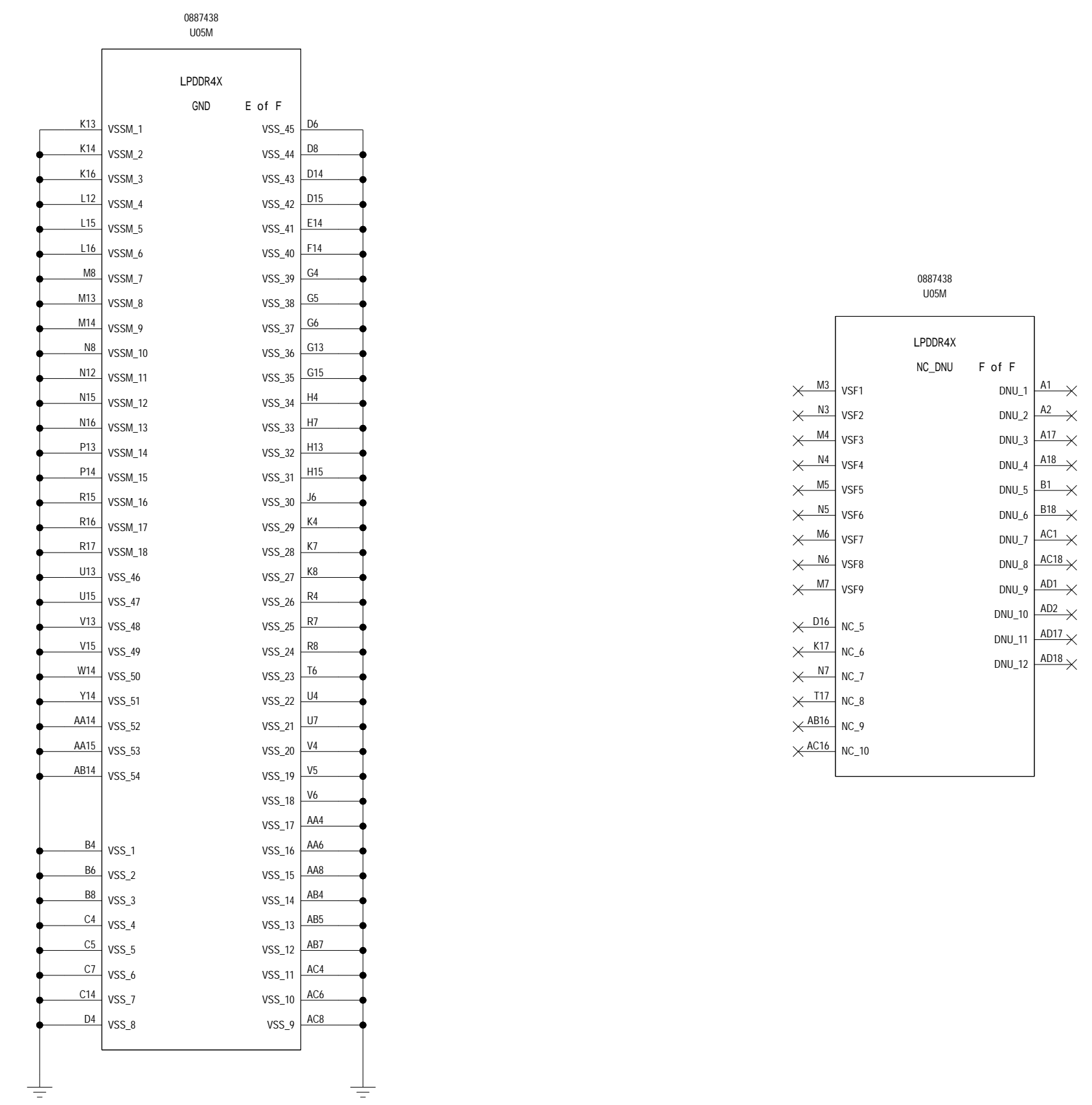
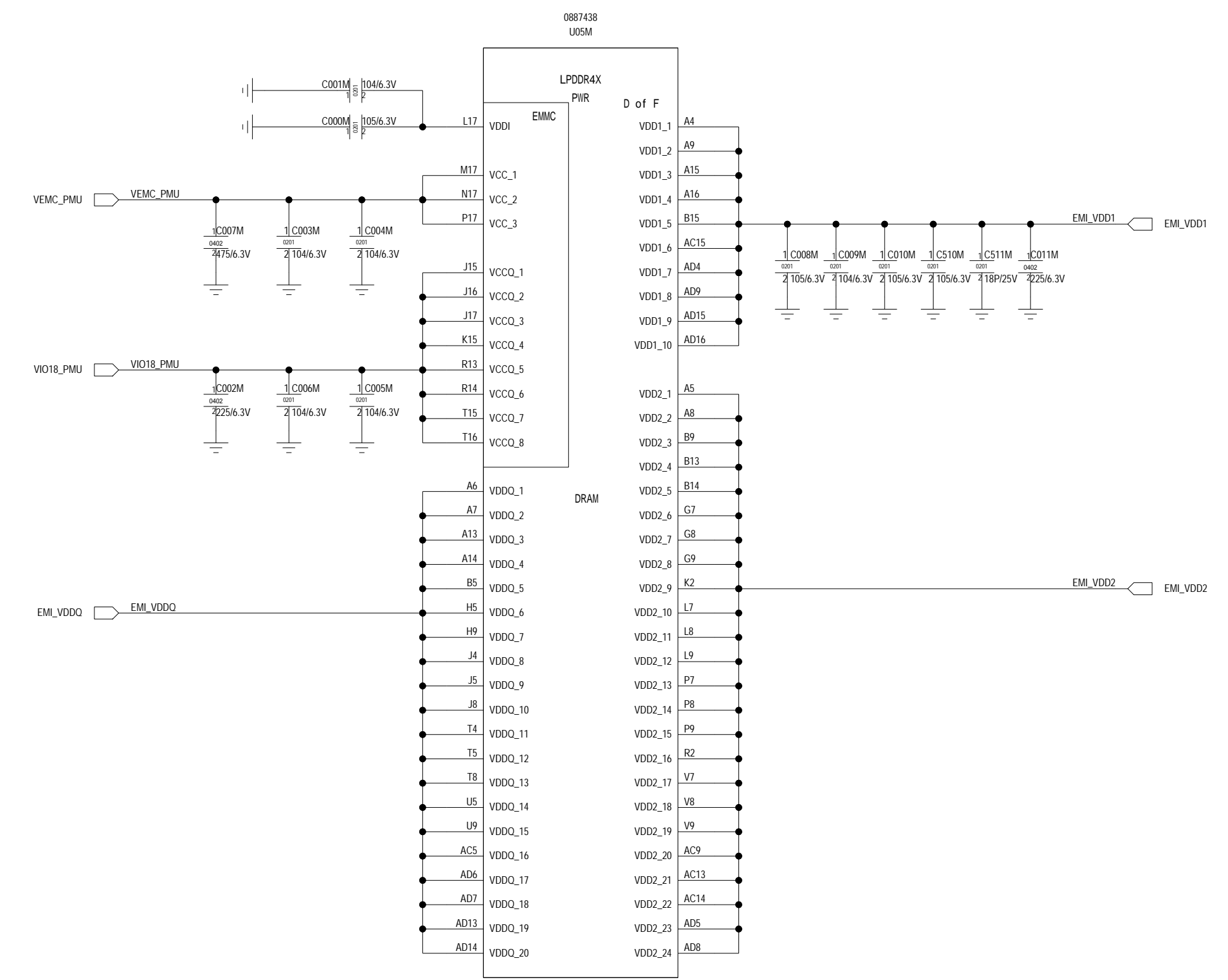
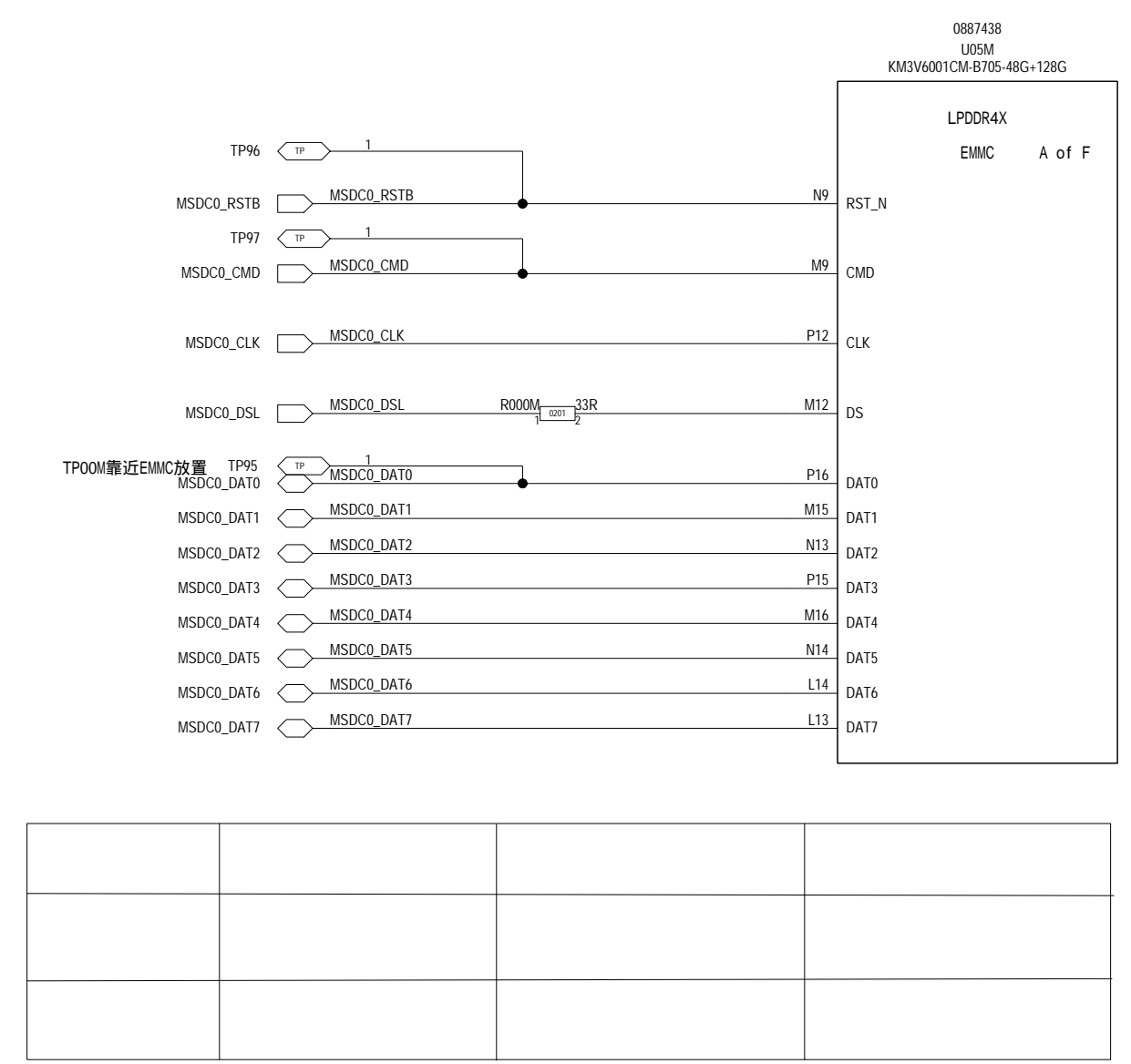

BOM\_VAR\_Name: \${VAR\_NAME}

BOM\_VAR\_Description: \${VAR\_DESC}

Company: vivo

Platform: MT6769V/CT

Project: PD2103BF/DF

Sheet Name: EMCP

Size: A1

Rev: -0

Drawn By: DingSong

Page: 13 of 27

Date: 17/06/2021:11:57

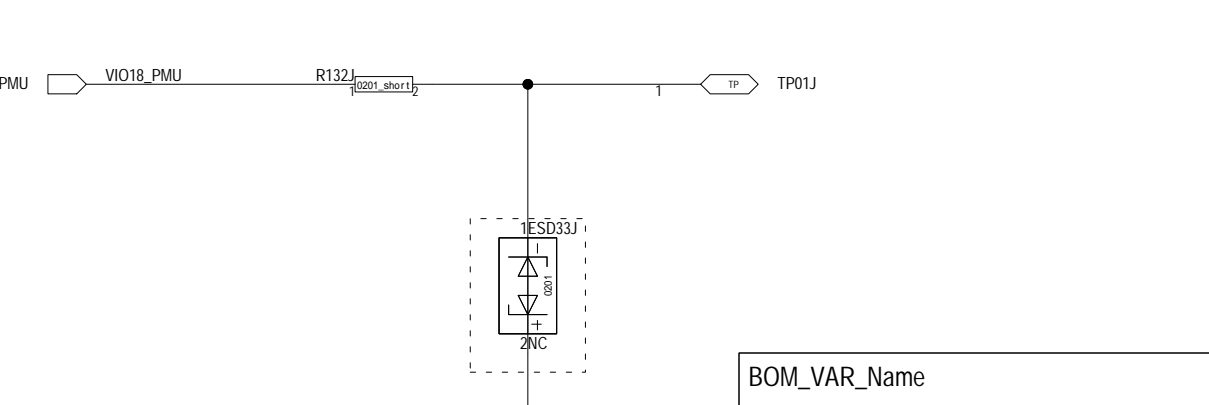
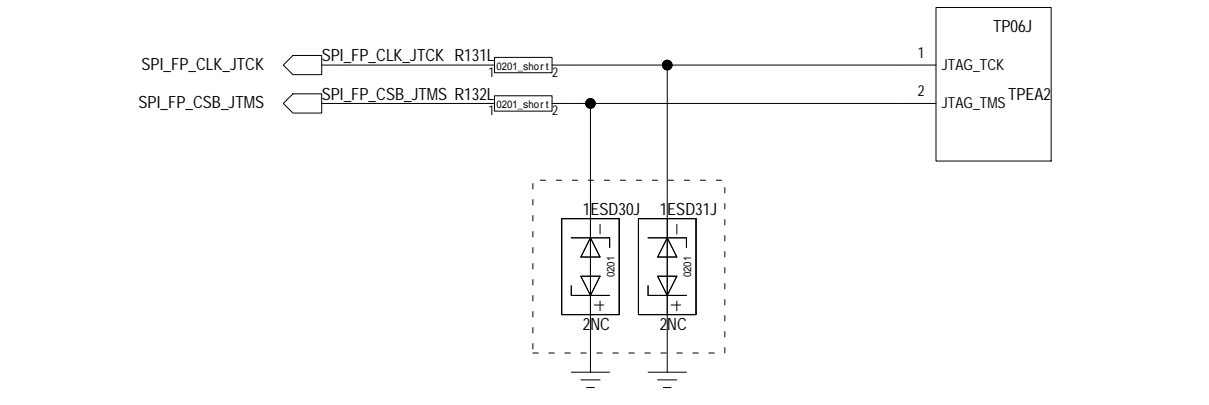
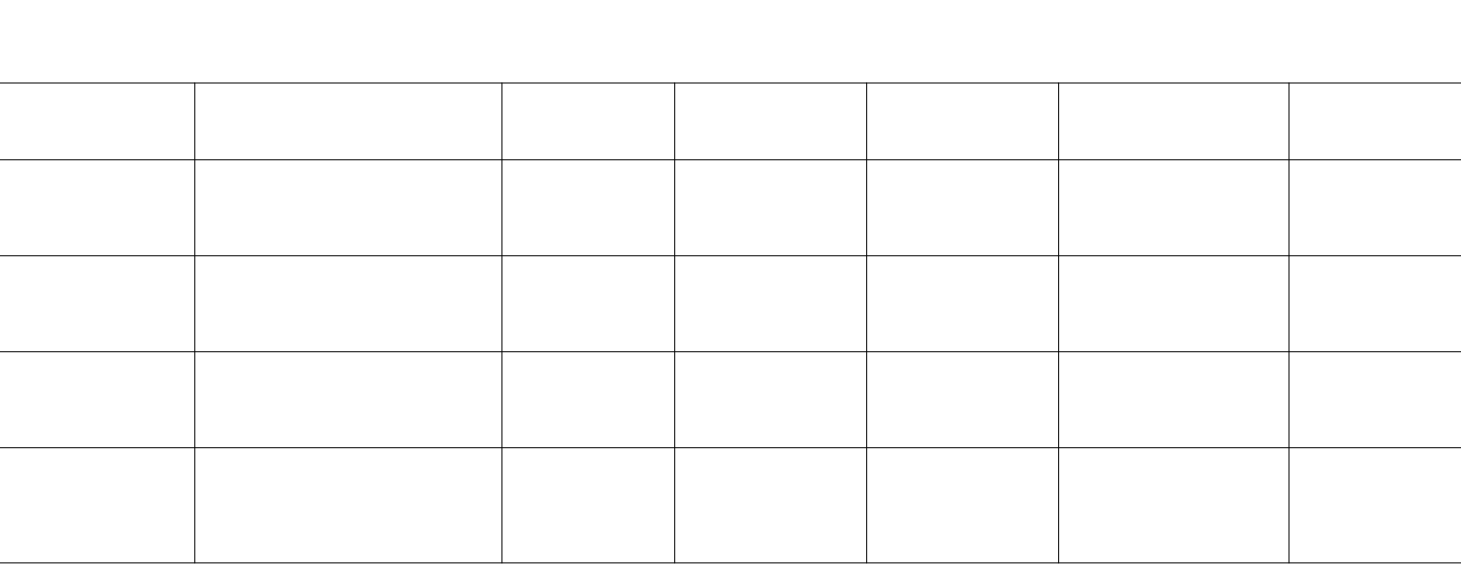
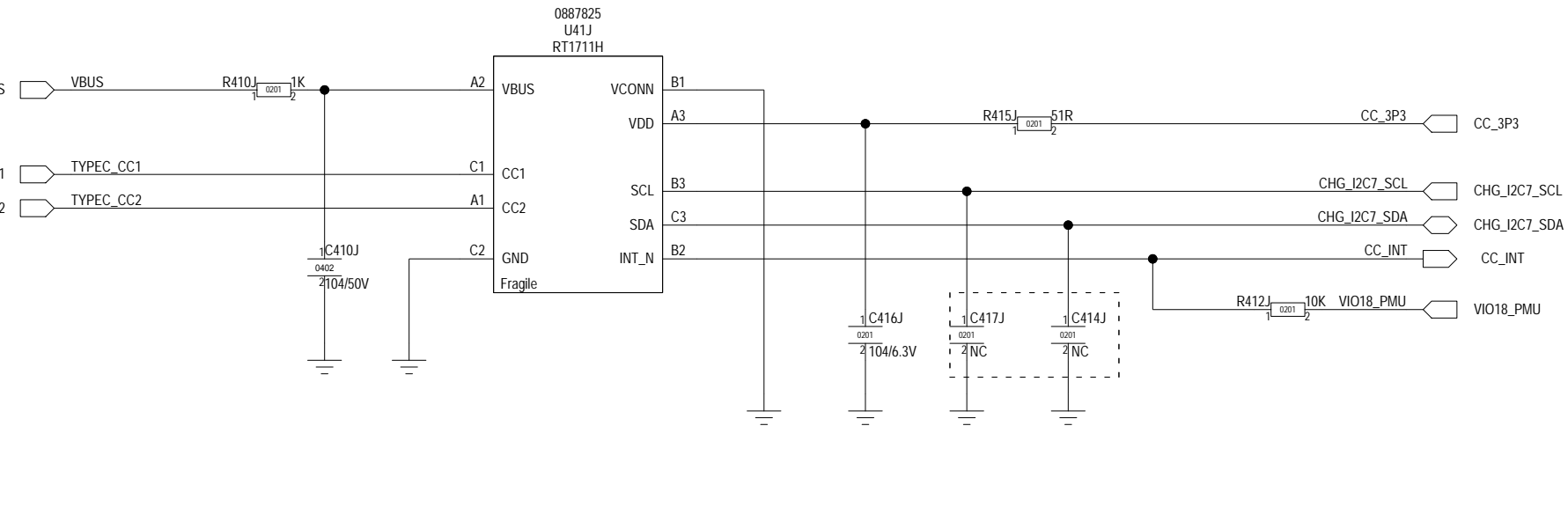
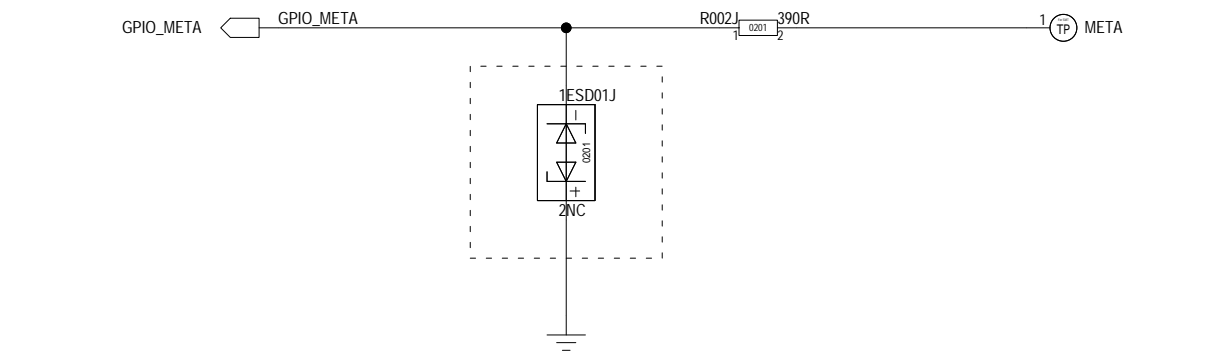
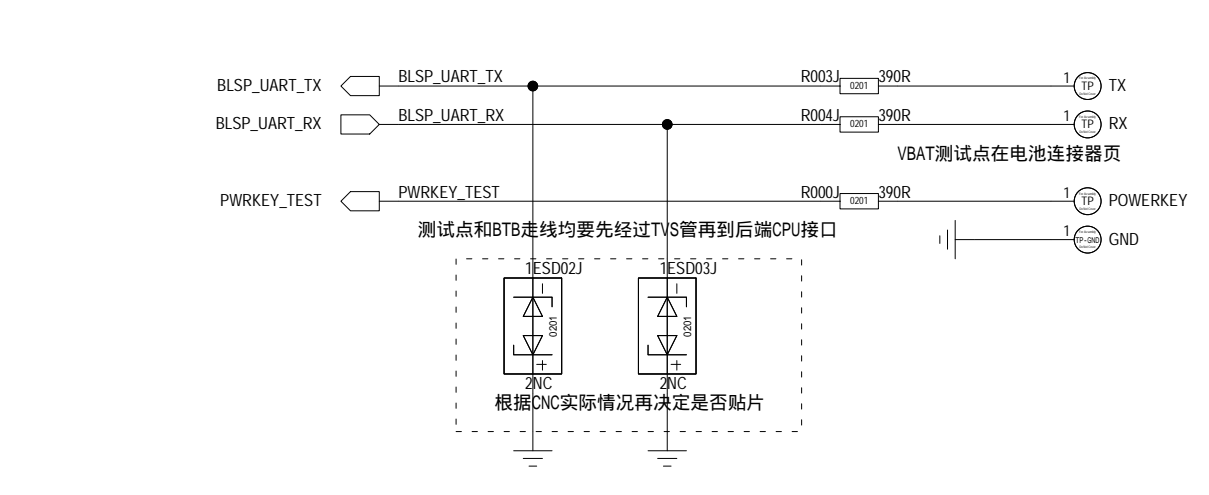
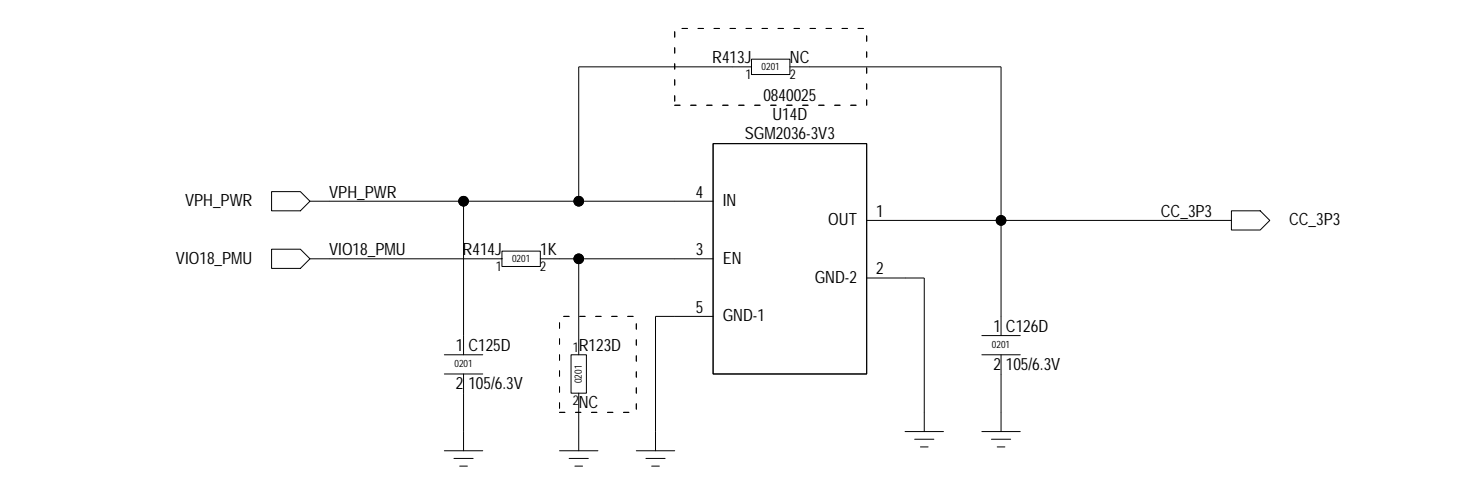
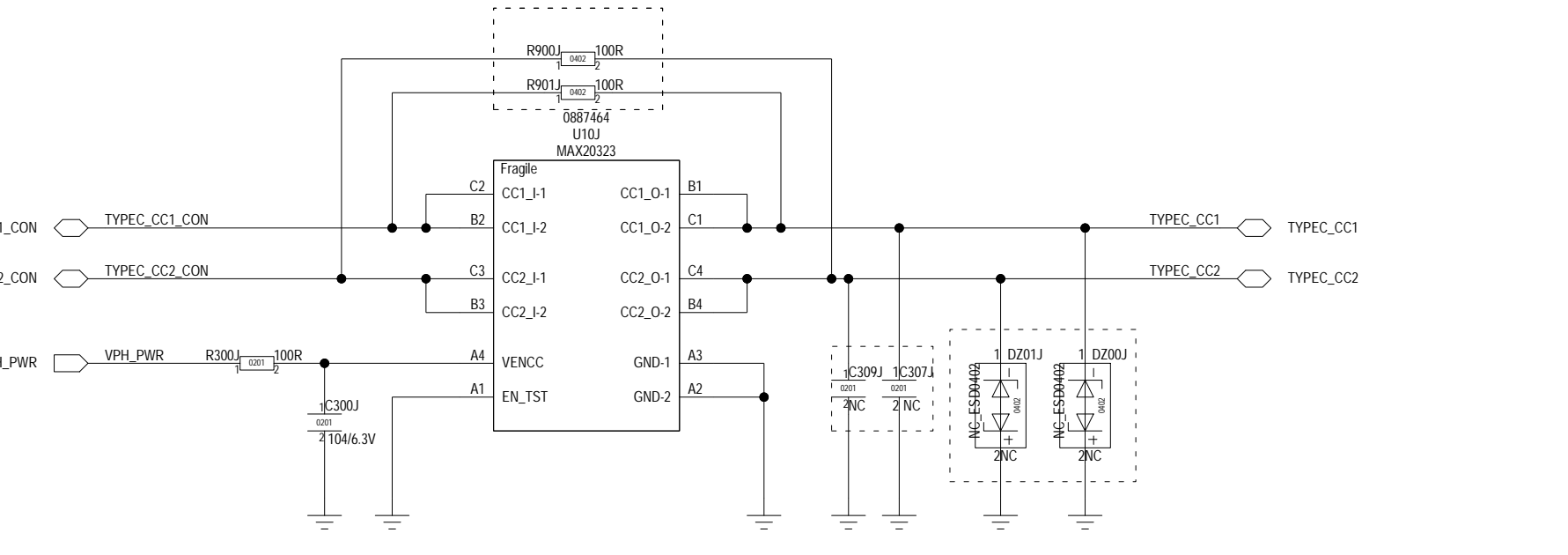
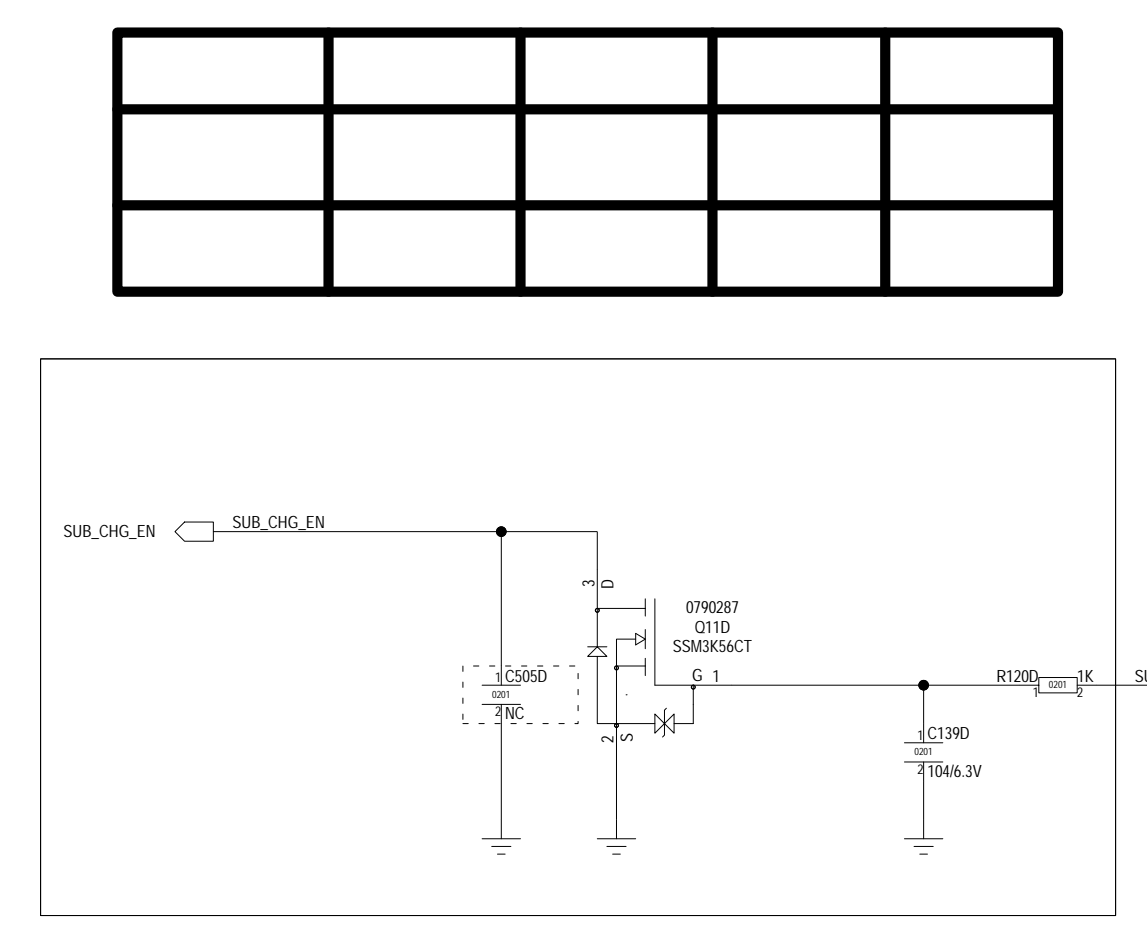
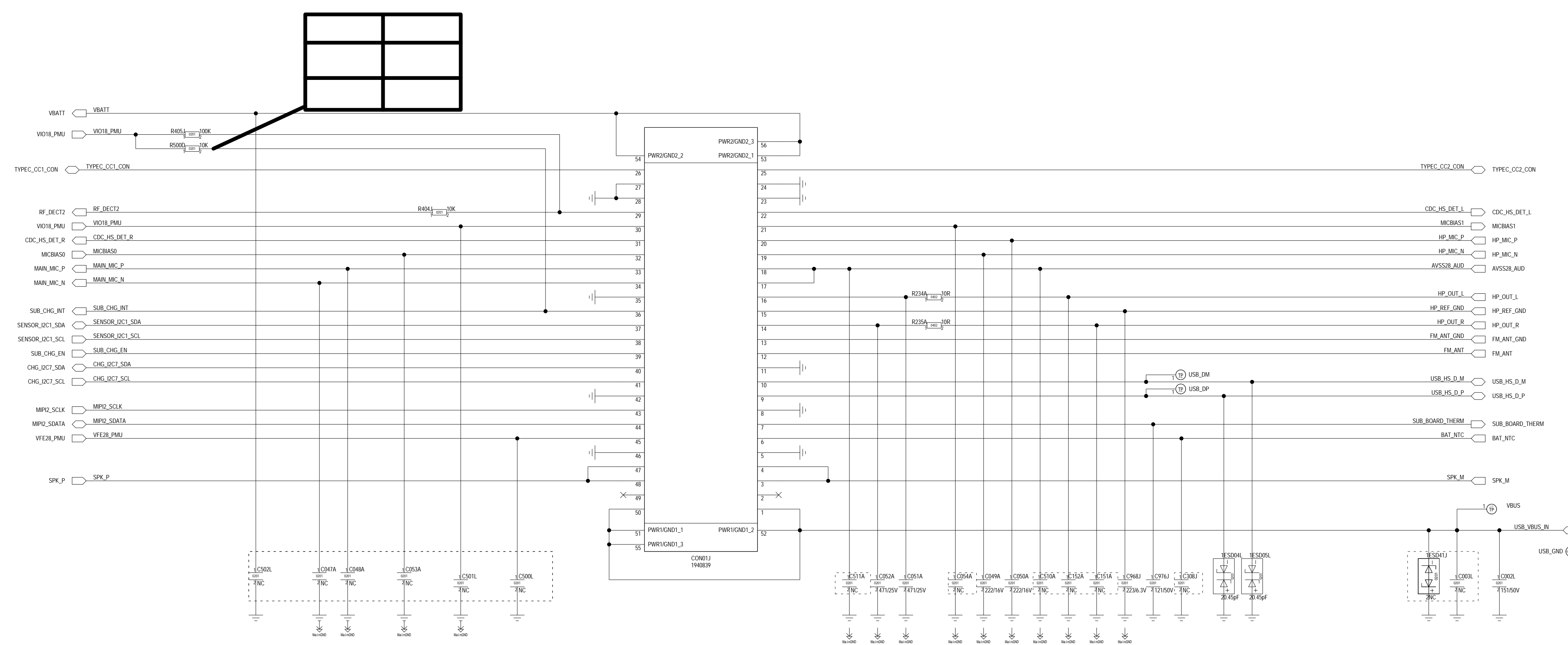

BOM_VAR_Name \${VAR_NAME}	
BOM_VAR_Description \${VAR_DESC}	
Company <b>vivo</b>	
Platform MT6769V/CT	Project PD2103BF/DF
Sheet Name MAIN_FPC_TEST	
Drawn By DingSong	Page 14 of 27
Date 17/06/2021:11:58	

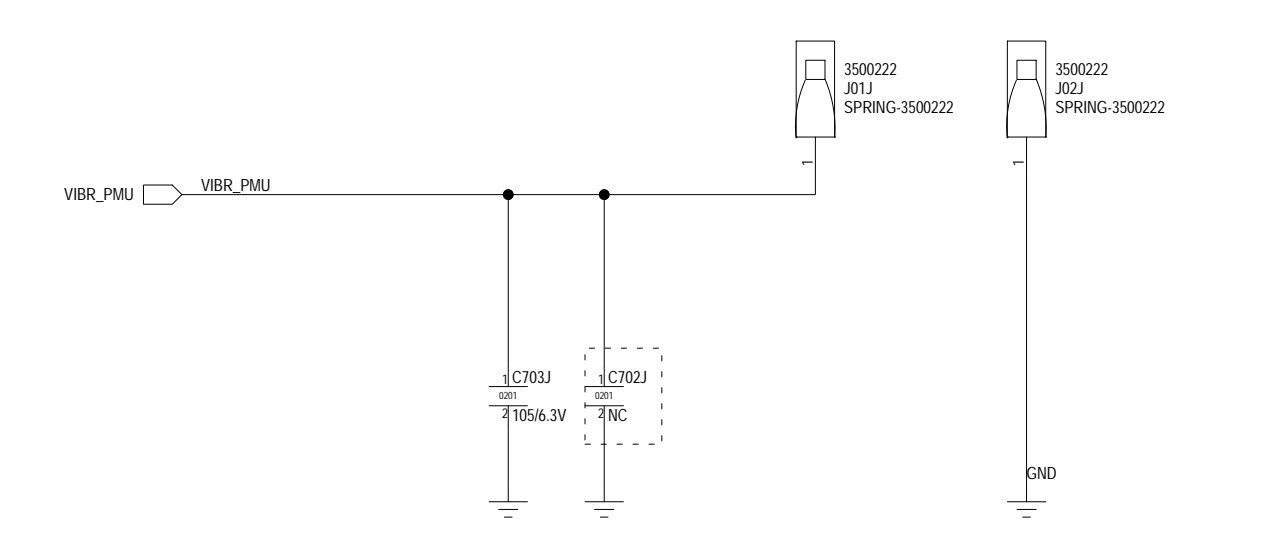
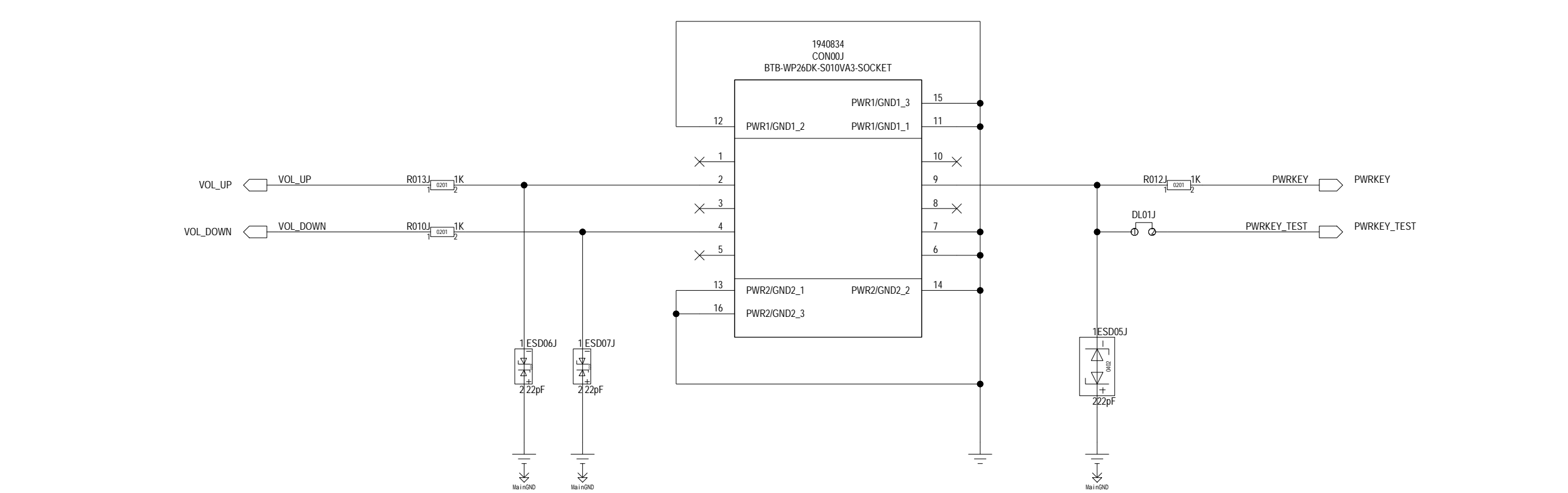
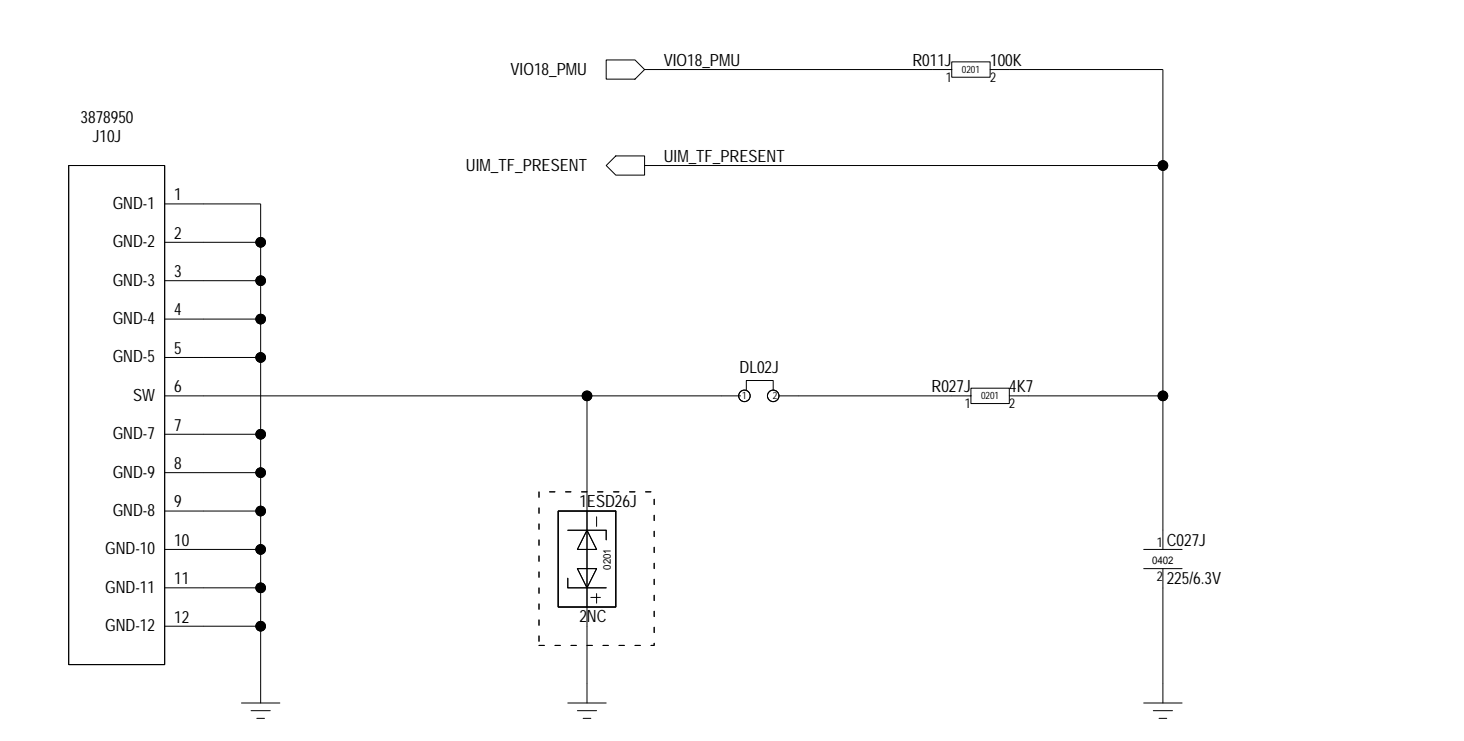
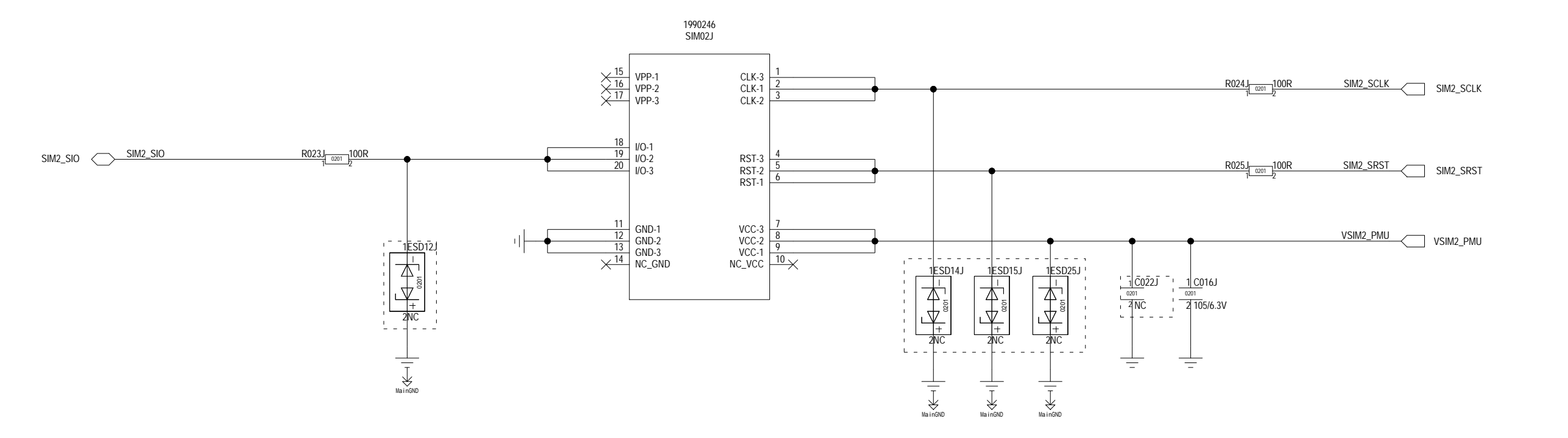
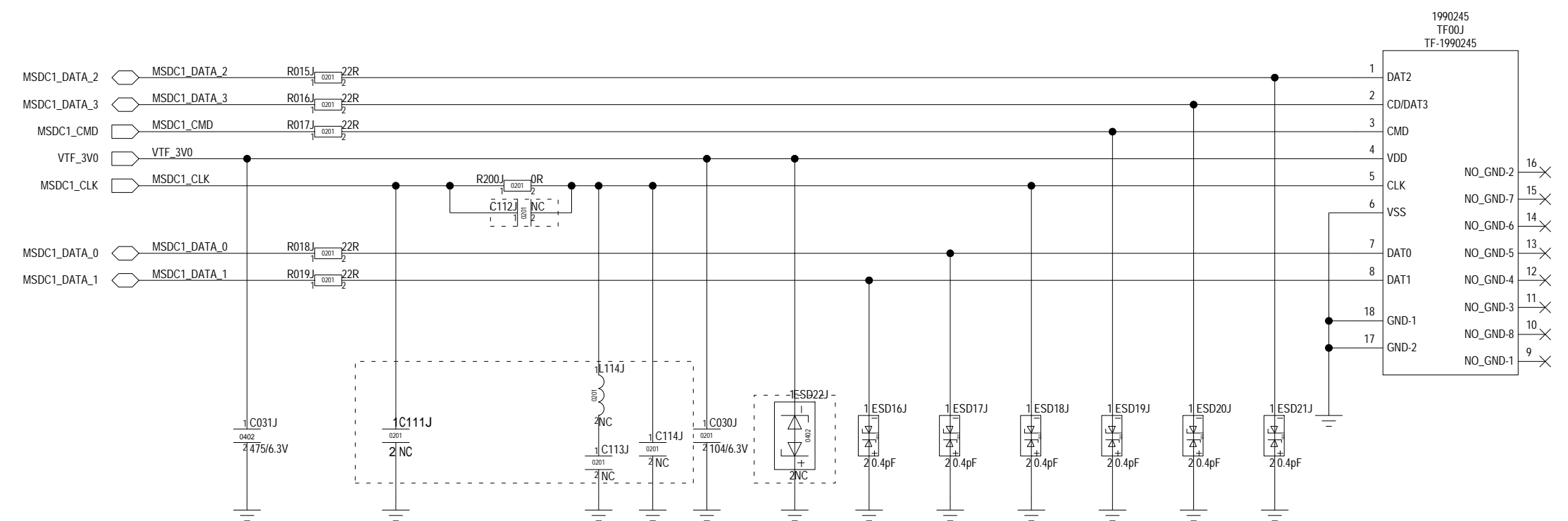
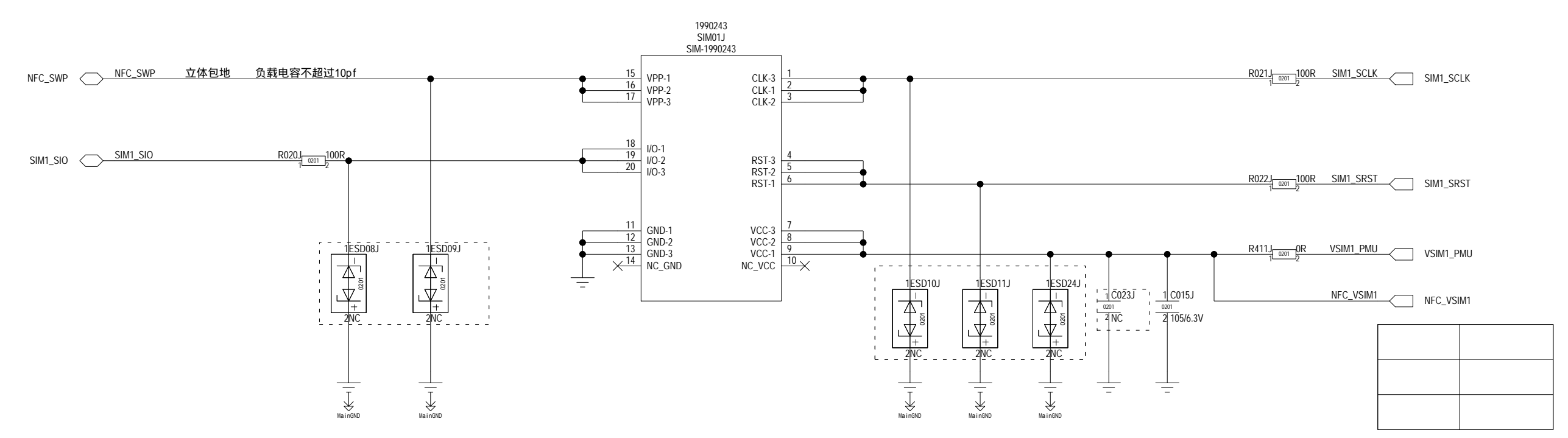

BOM\_VAR\_Name  
\${VAR\_NAME}

BOM\_VAR\_Description  
\${VAR\_DESC}

Company  
**vivo**

Platform  
MT6769V/CT

Project  
PD2103BF/DF

Sheet Name  
TF\_SIM\_KEY\_MOTO

Size  
A1

Rev  
-0

Drawn By  
DingSong

Page  
15 of 27

17/06/2021:11:58

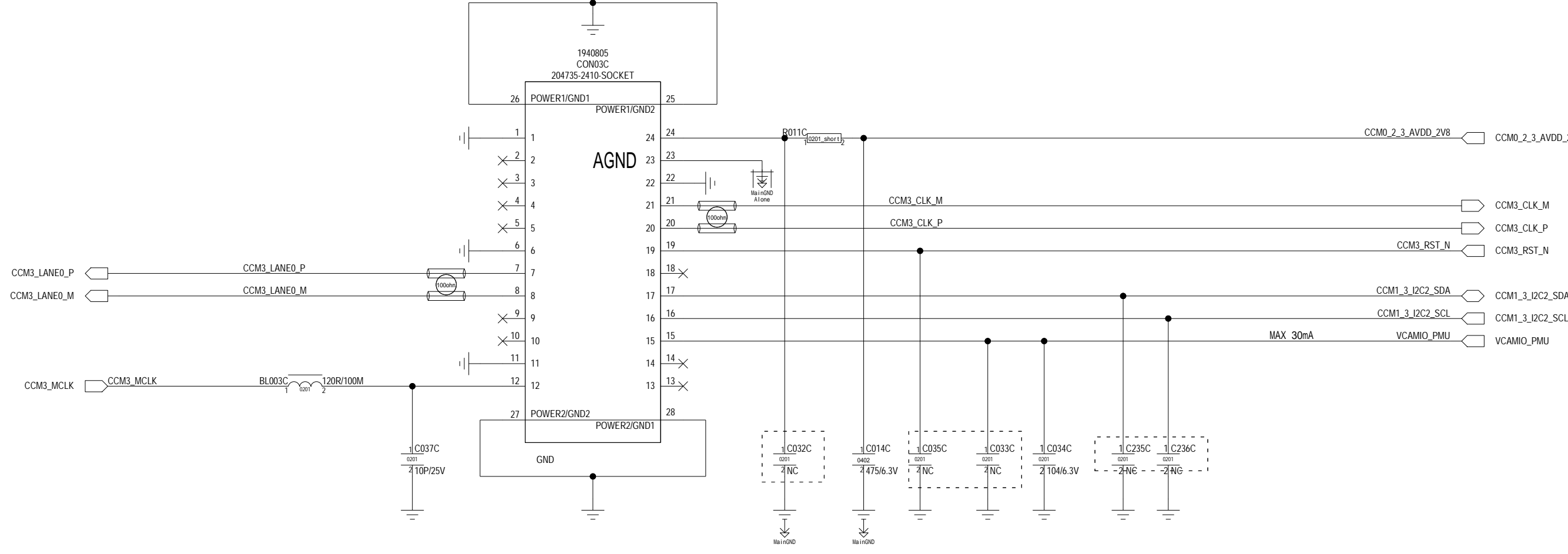
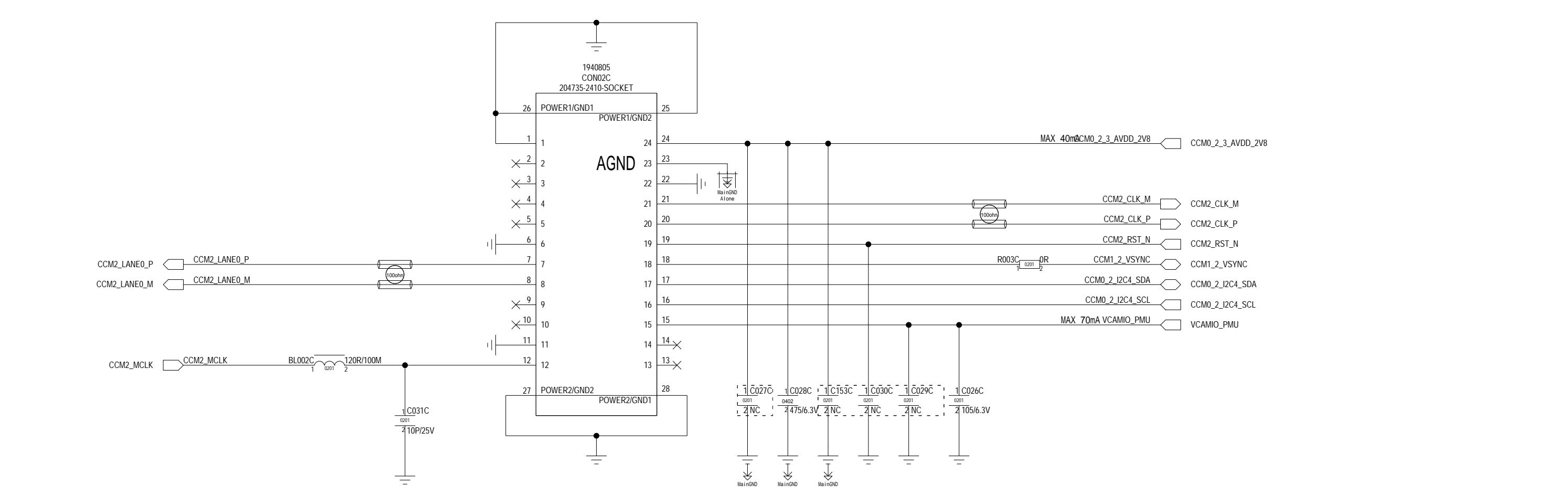
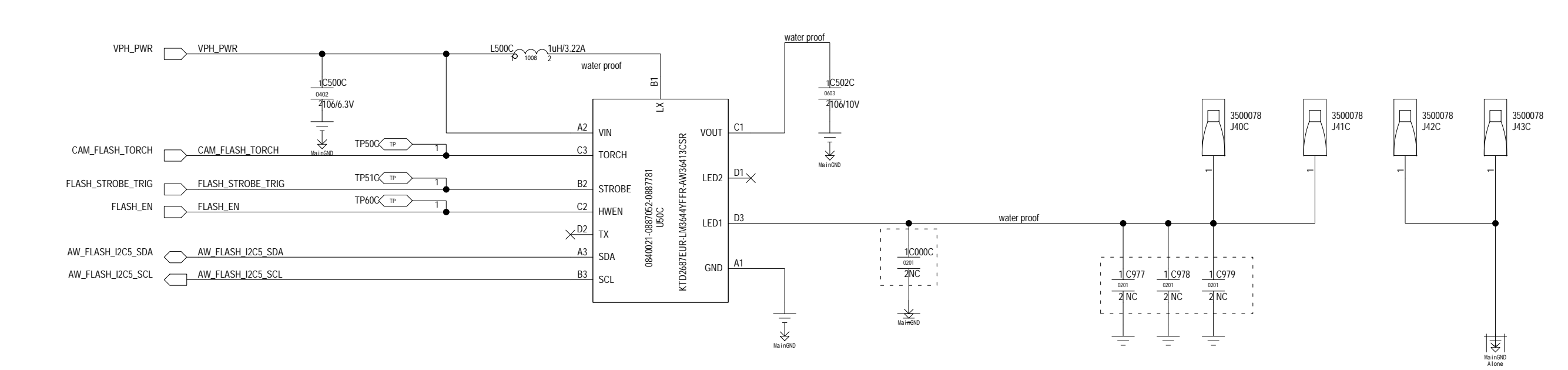
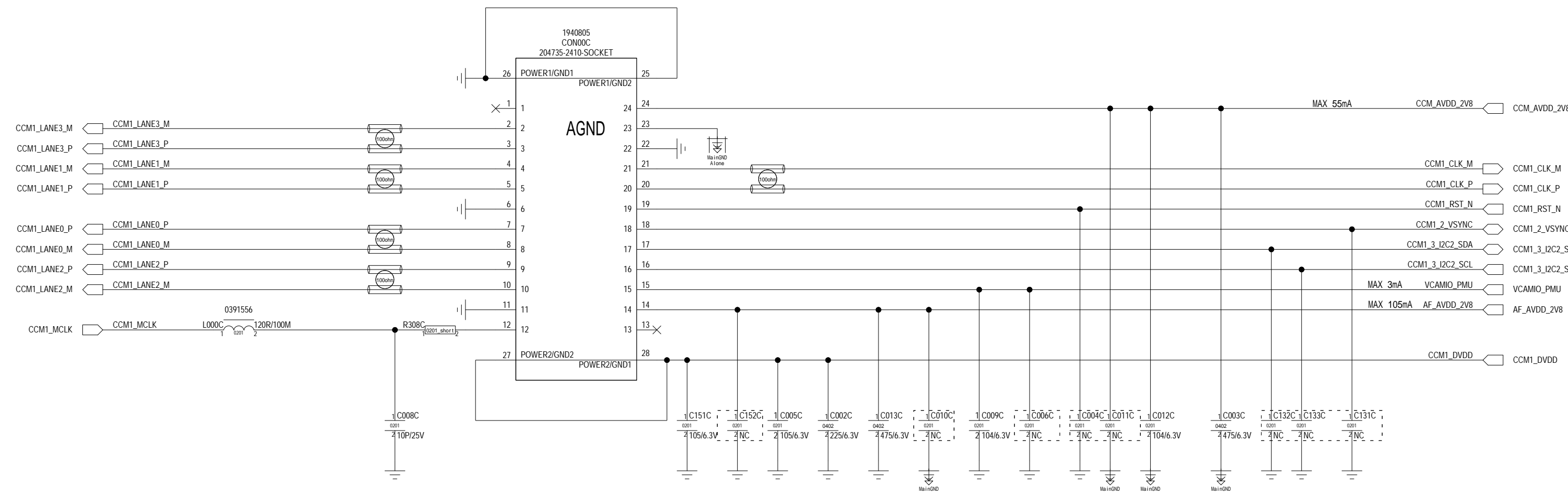

BOM\_VAR\_Name  
\${VAR\_NAME}

BOM\_VAR\_Description  
\${VAR\_DESC}

Company <b>vivo</b>	
PlatForm MT6769V/CT	Project PD2103BF/DF
Sheet Name REAR_CCM_FLASH	Size A1 Rev -0
Drawn By DingSong	Page 16 of 27 17/06/2021:11:58



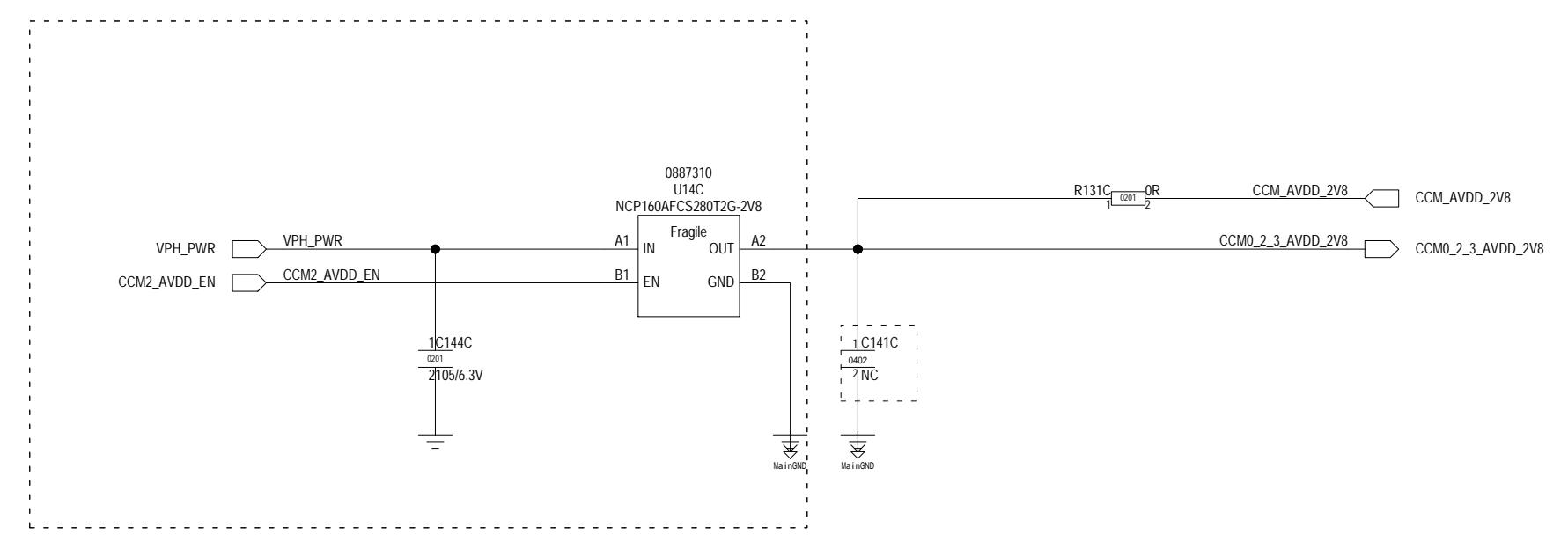
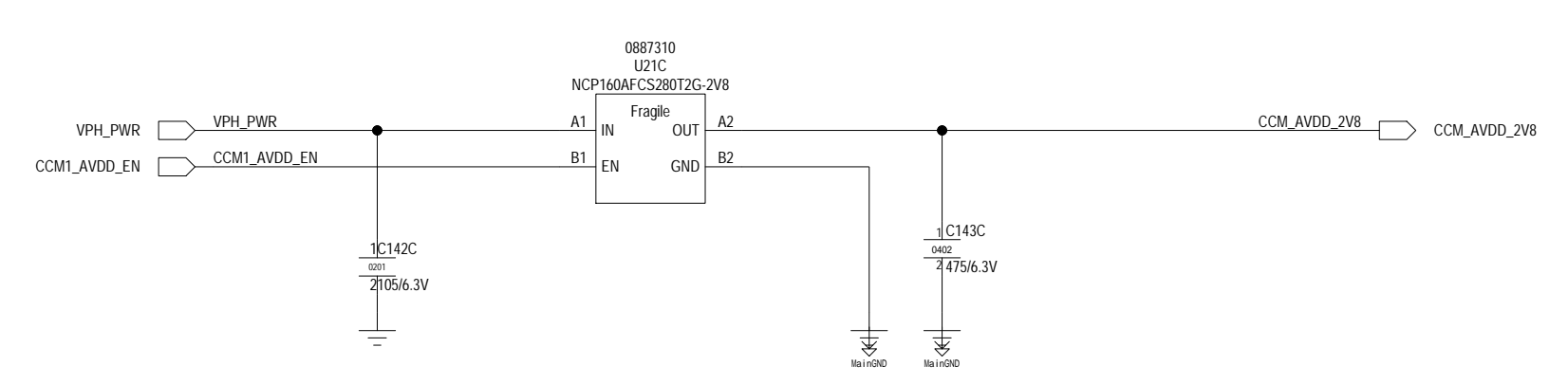
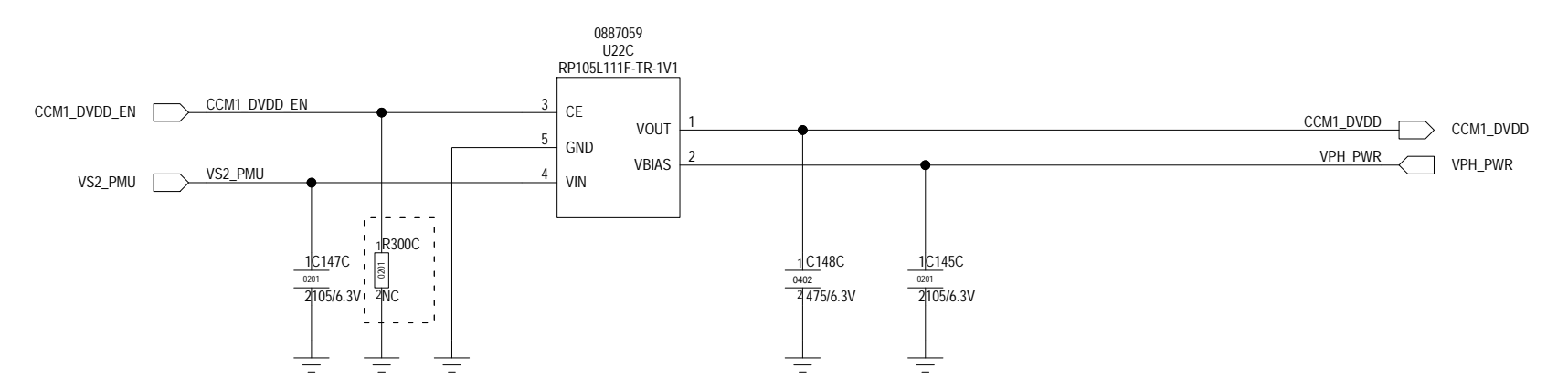
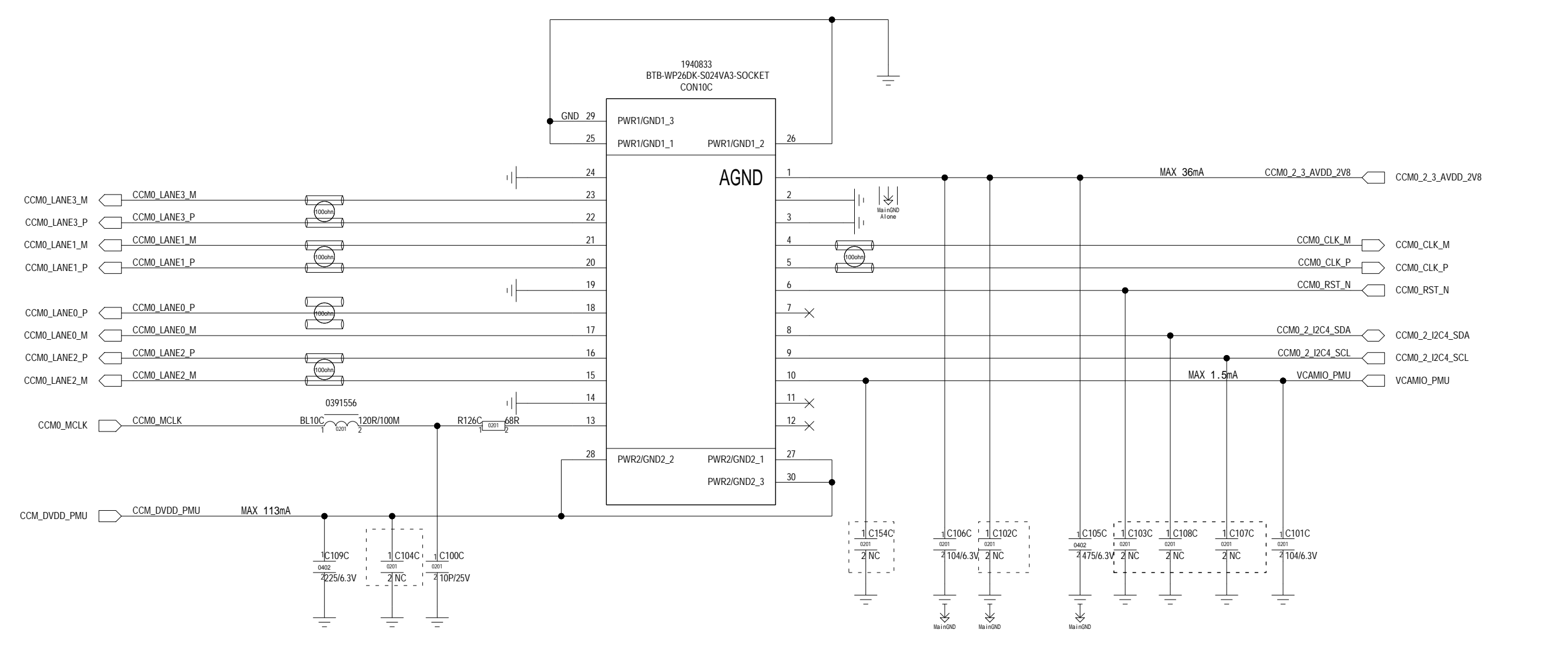

BOM\_VAR\_Name  
 \${VAR\_NAME}  
 BOM\_VAR\_Description  
 \${VAR\_DESC}

Company **vivo**

Platform **MT6769V/CT** Project **PD2103BF/DF**

Sheet Name **FRONT\_CCM\_LDO** Size **A1**  
 Rev **-0**

Drawn By **DingSong** Page **17 of 27** 17/06/2021:11:59

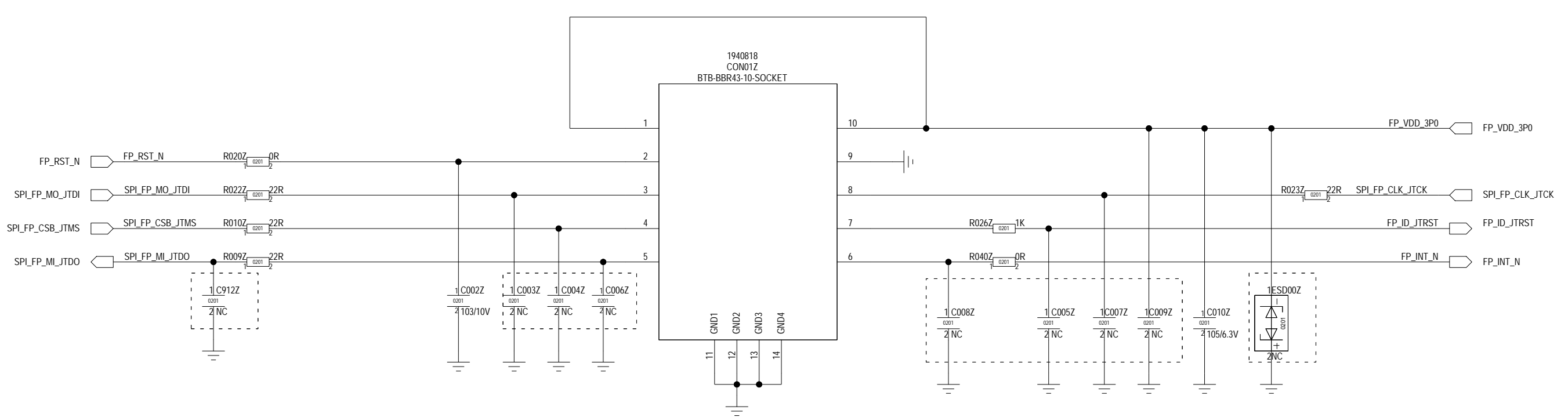
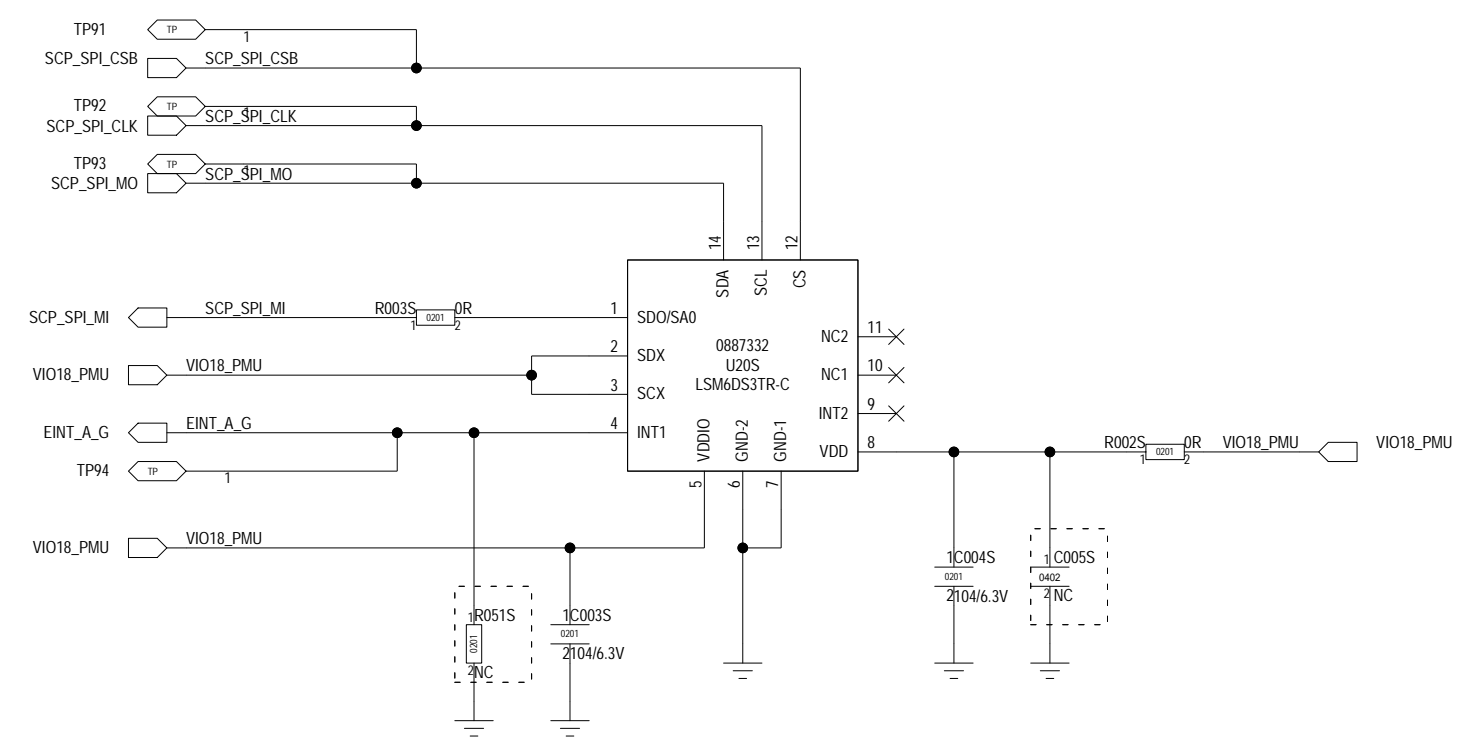
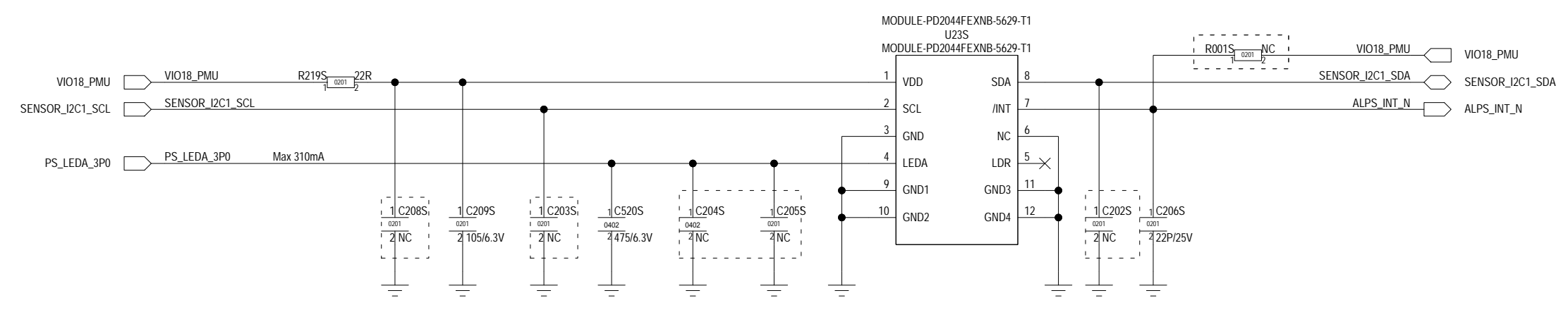
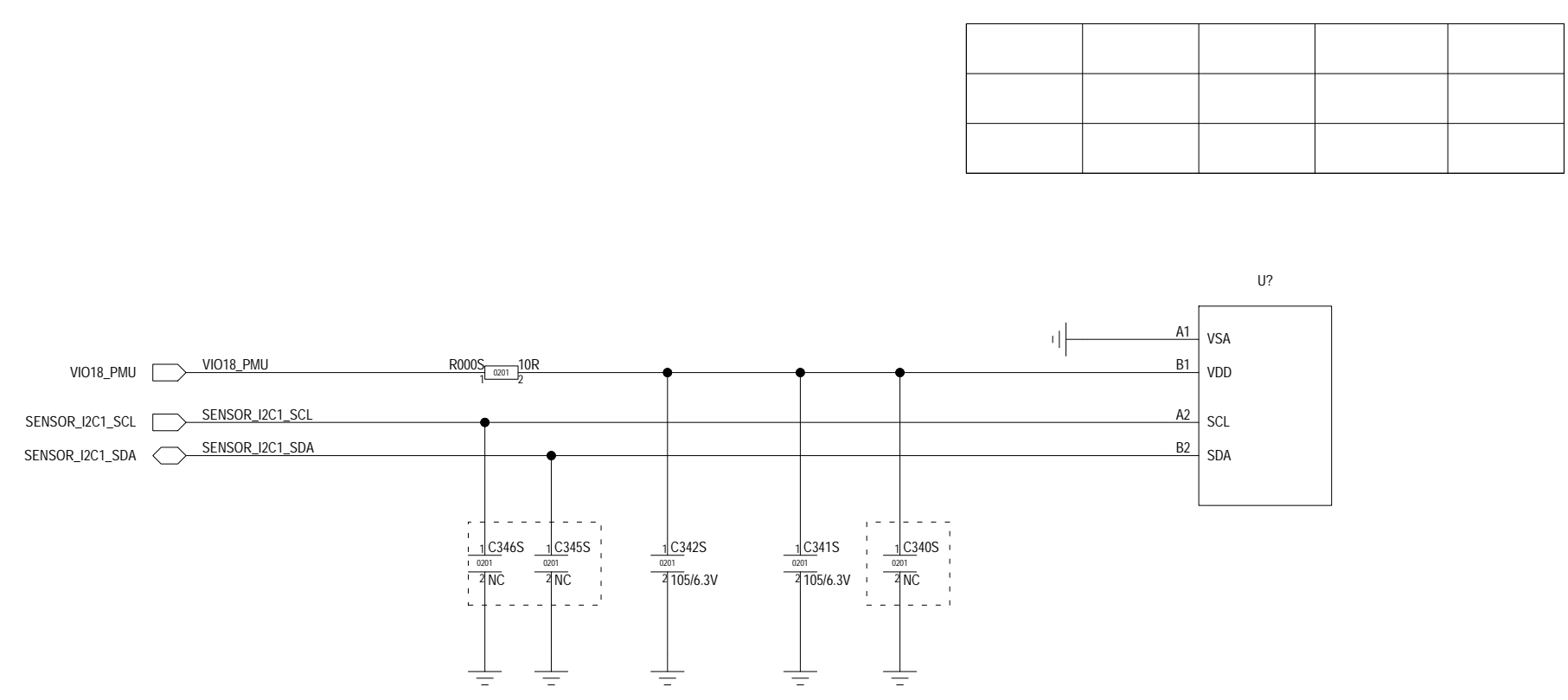

BOM\_VAR\_Name  
\${VAR\_NAME}

BOM\_VAR\_Description  
\${VAR\_DESC}

Company		<b>vivo</b>	
PlatForm	MT6769V/CT	Project	PD2103BF/DF
Sheet Name	SENSOR_FINGERPRINT		Size A1
			Rev -0
Drawn By	DingSong	Page	18 of 27
			17/06/2021:11:59

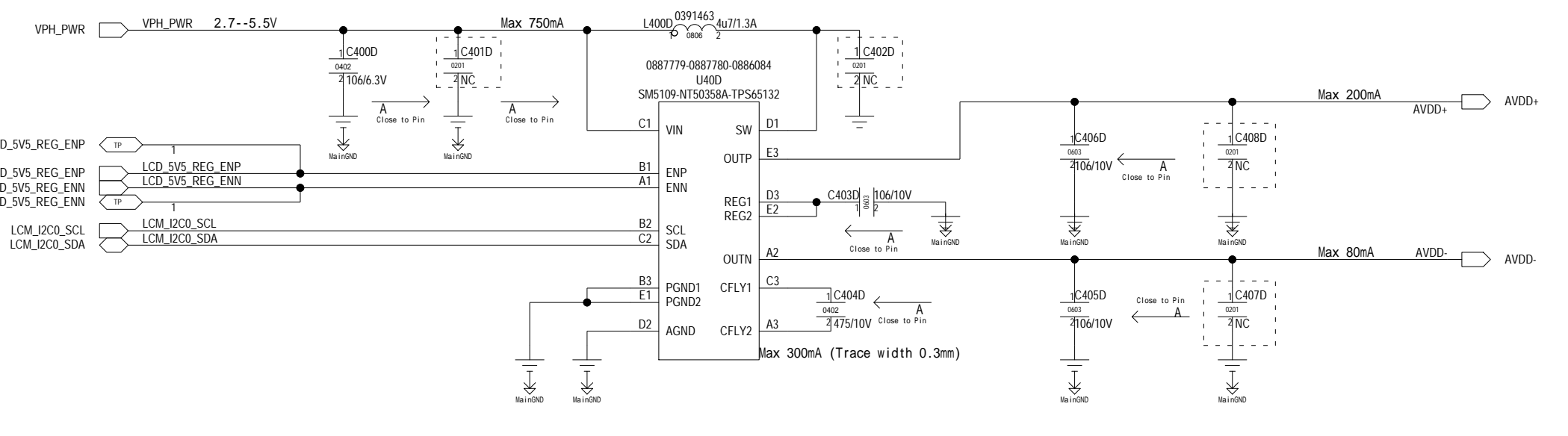
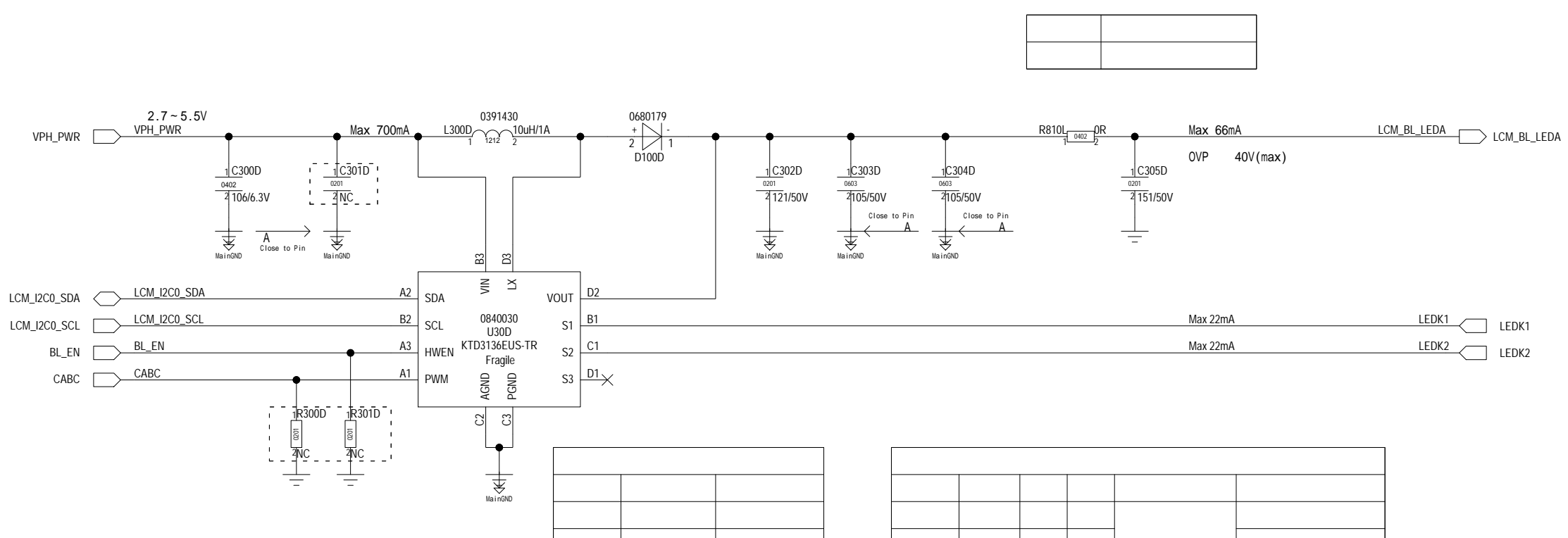
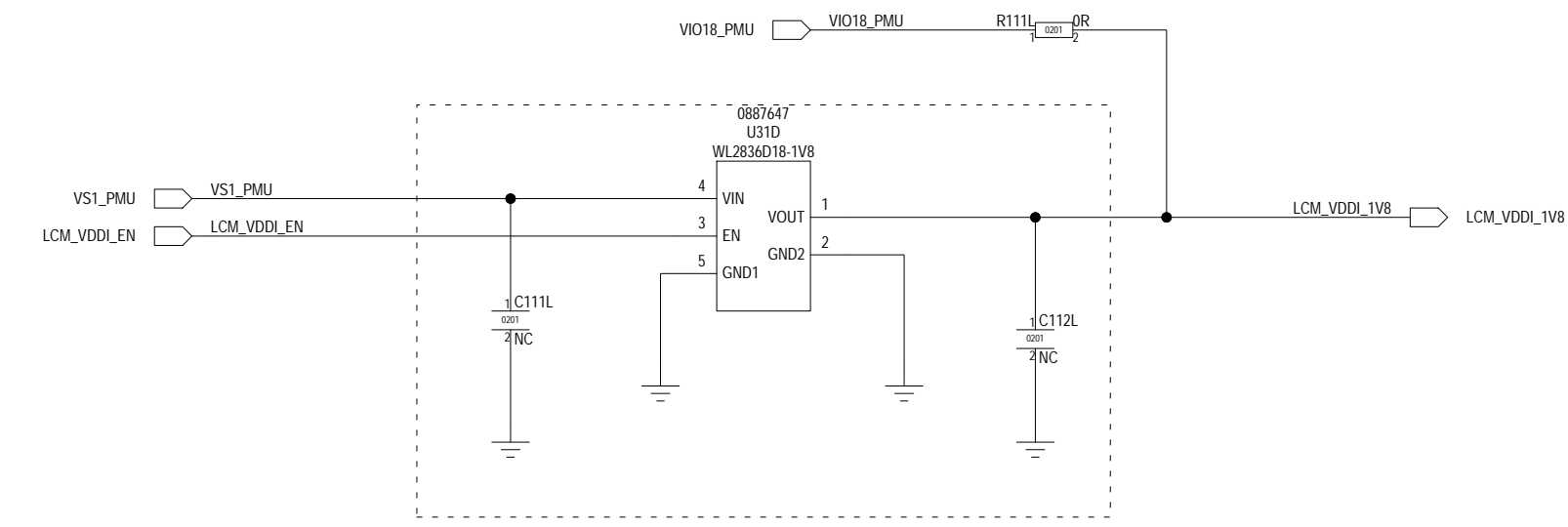
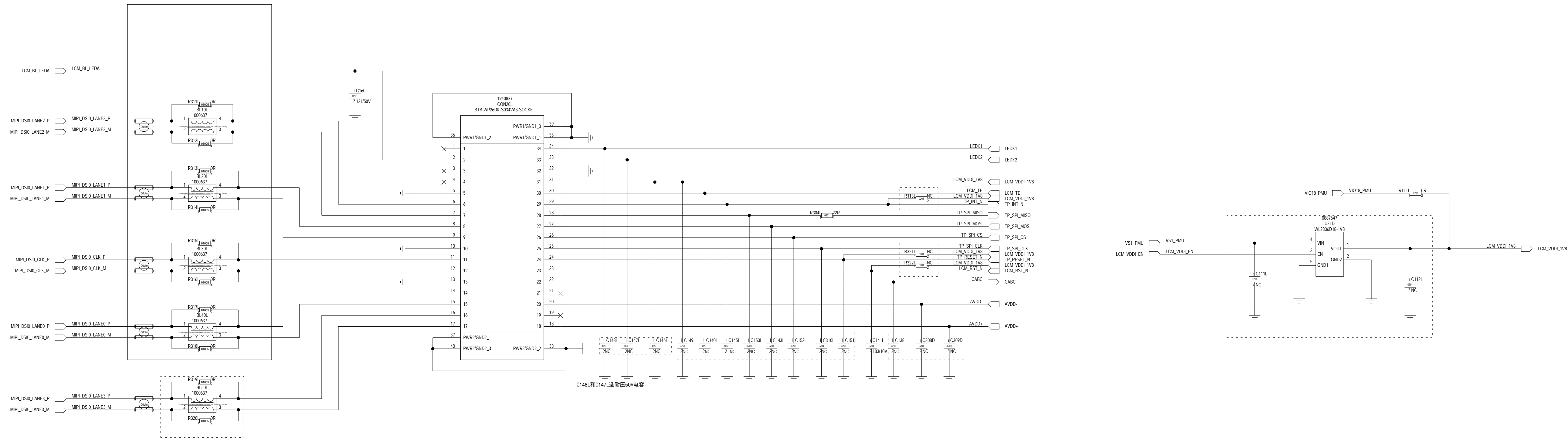

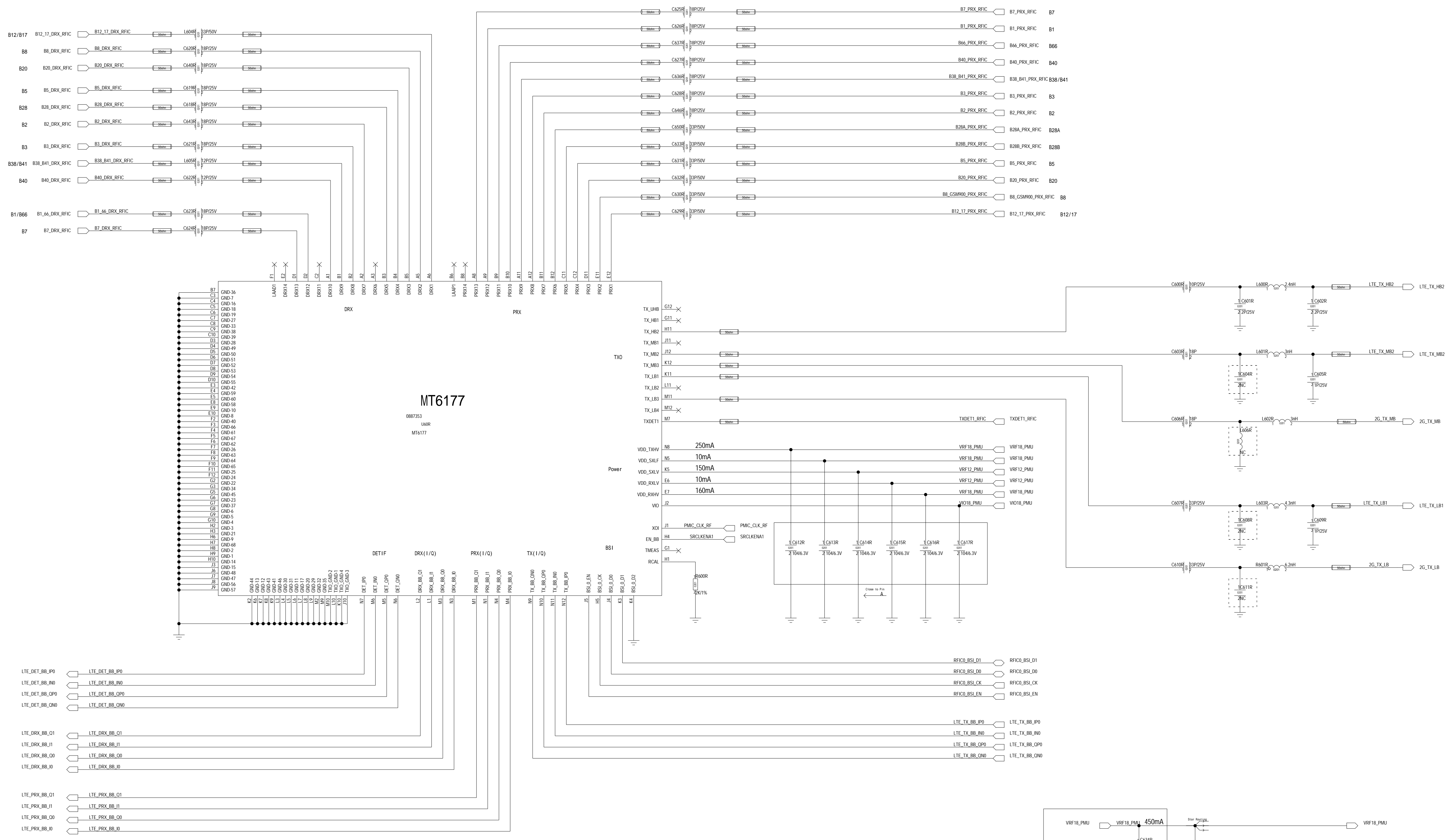

BOM_VAR_Name \${VAR_NAME}	
BOM_VAR_Description \${VAR_DESC}	
Company <b>vivo</b>	
PlatForm MT6769V/CT	Project PD2103BF/DF
Sheet Name LCM	Size A1 Rev -0
Drawn By DingSong	Page 19 of 27 17/06/2021:12:00

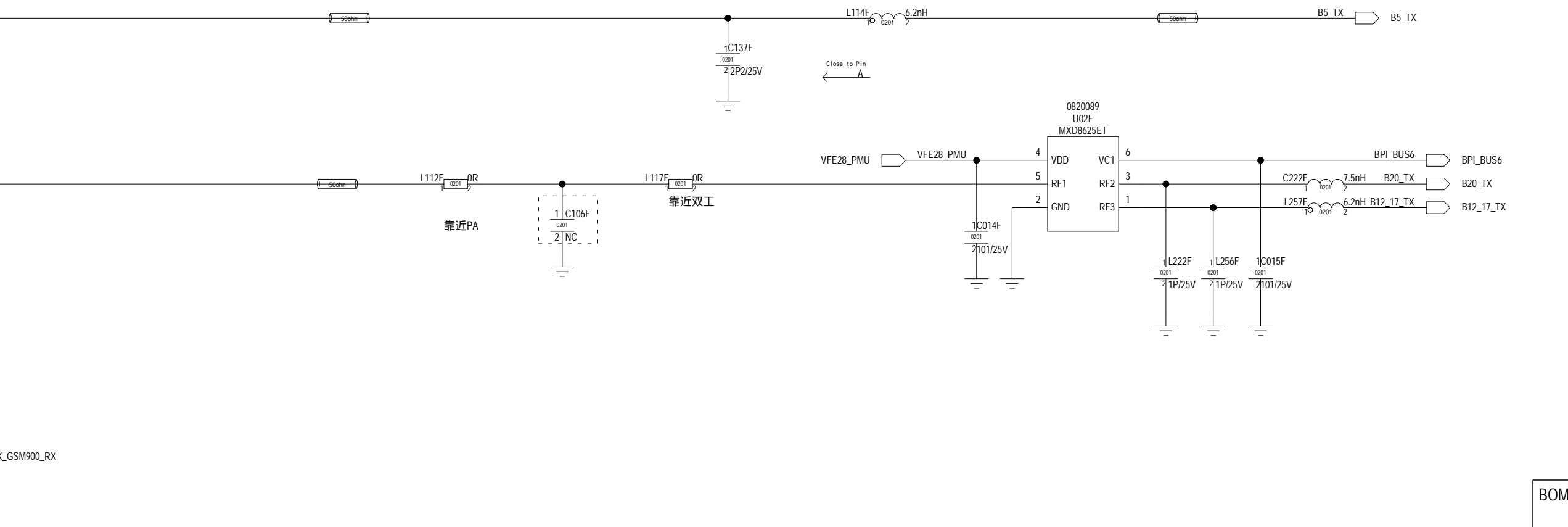
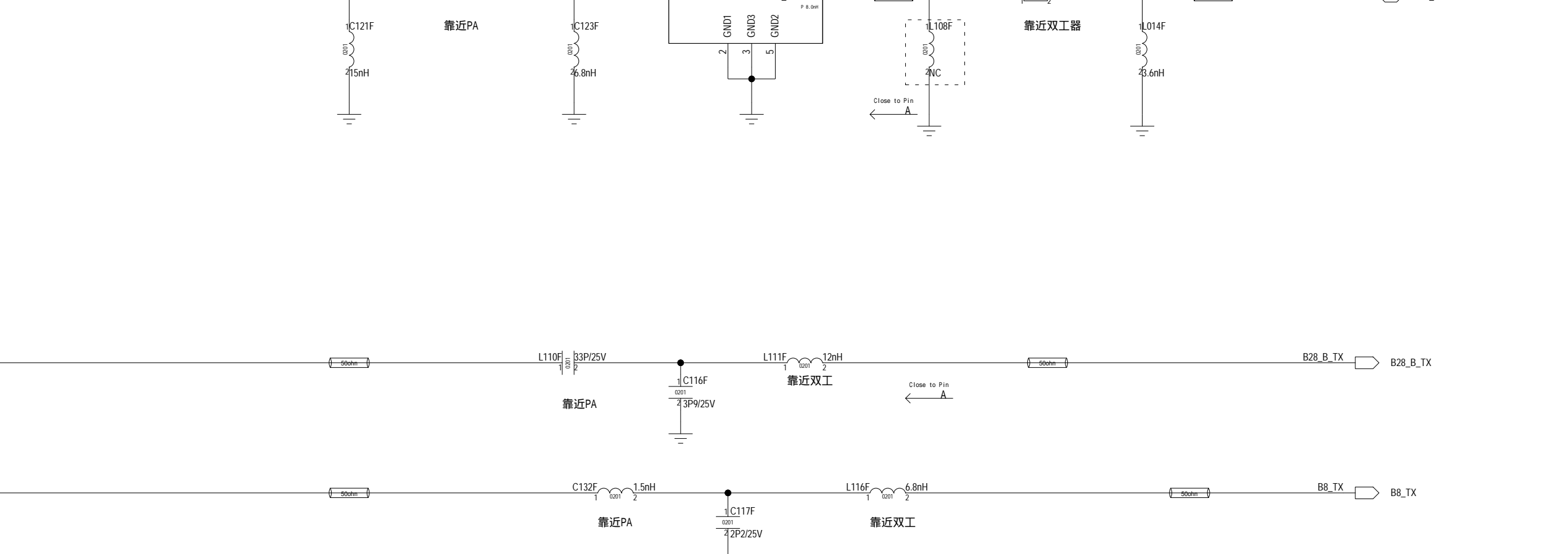
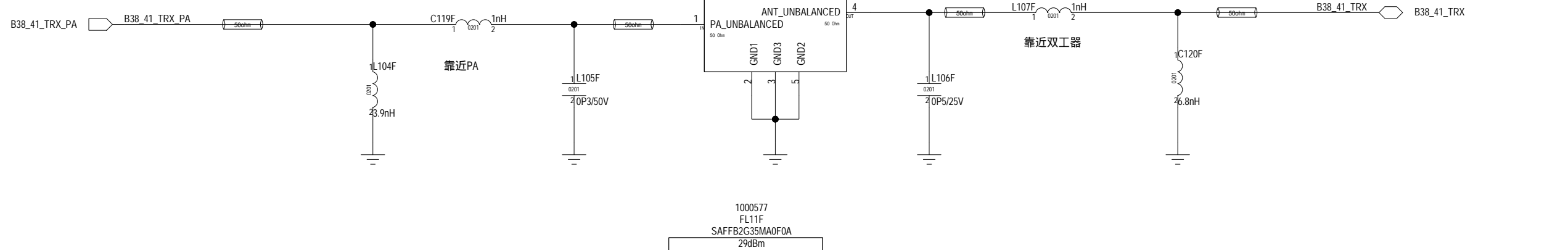
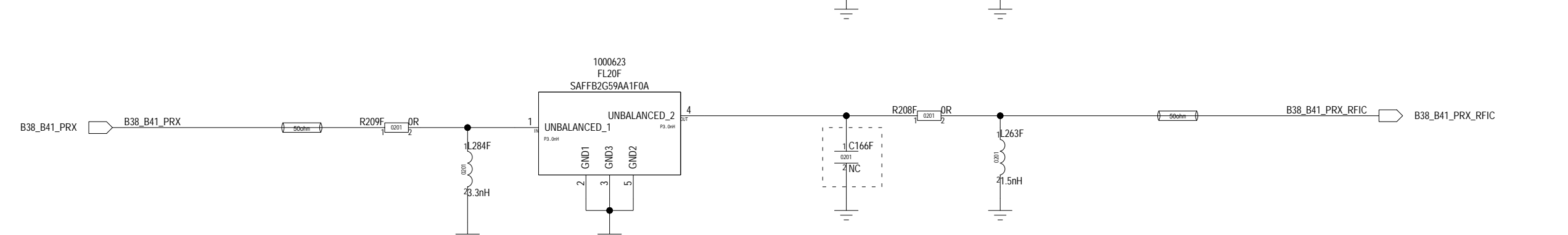
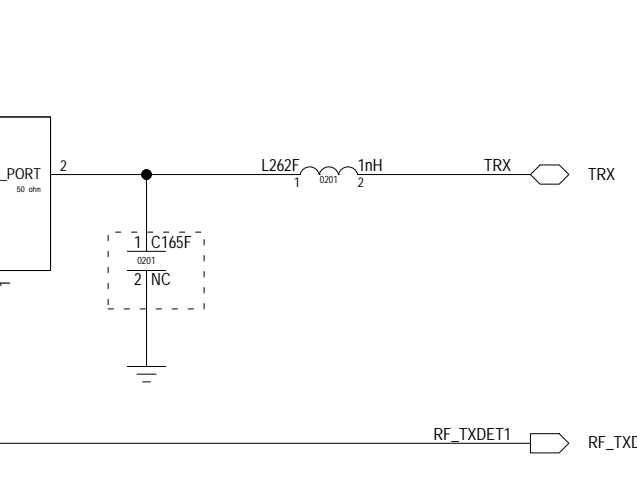
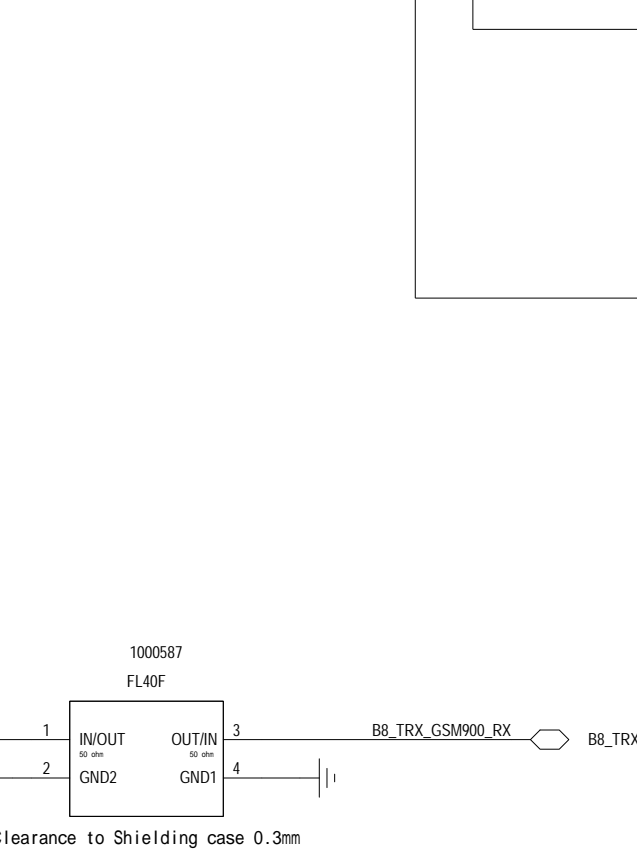
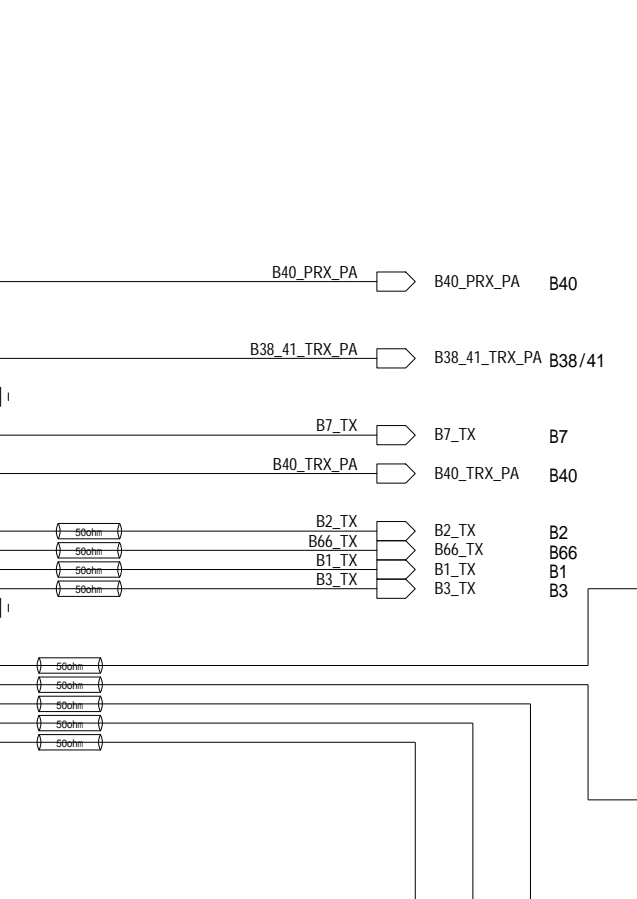
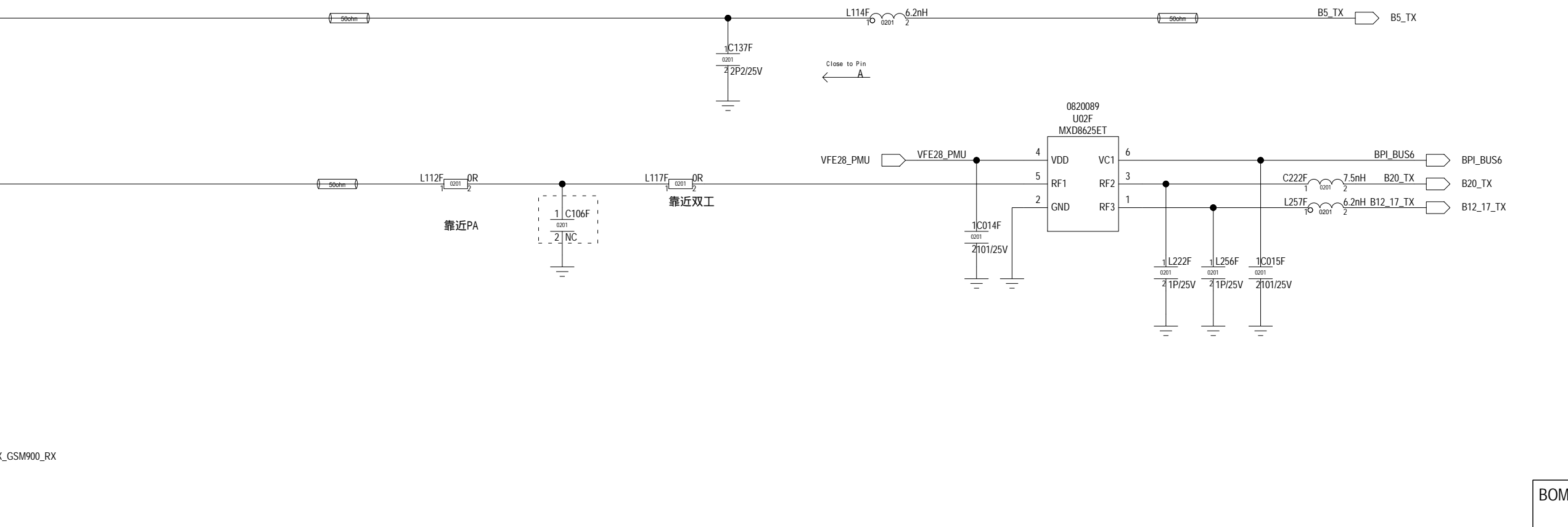
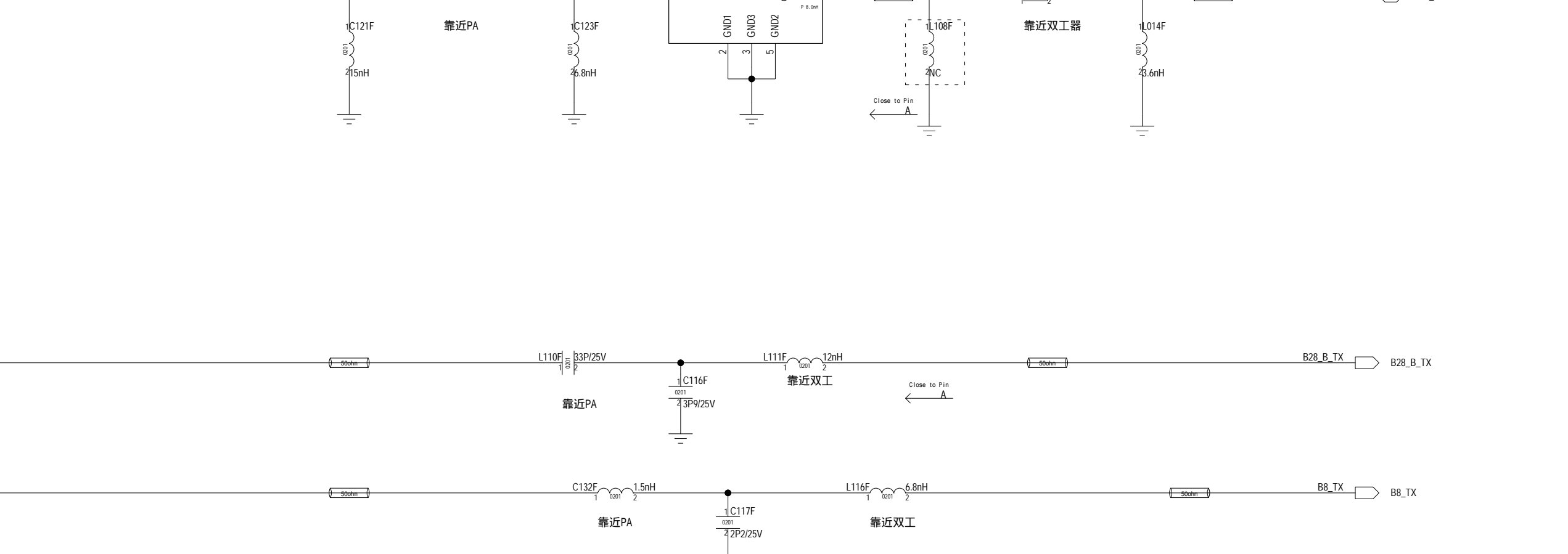
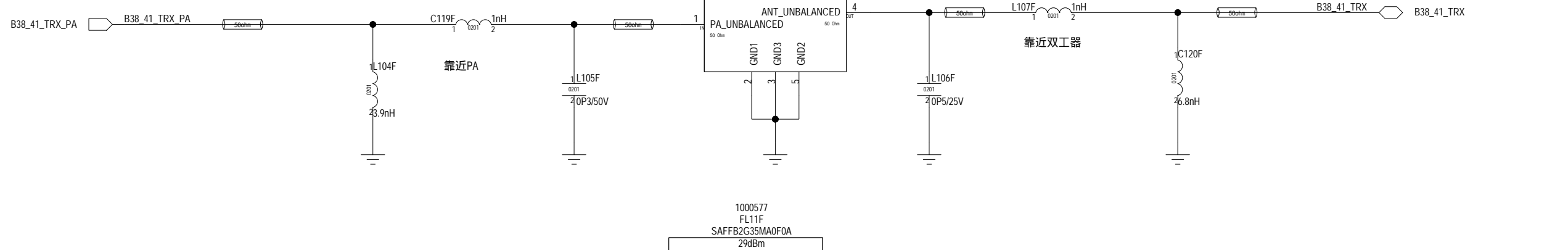
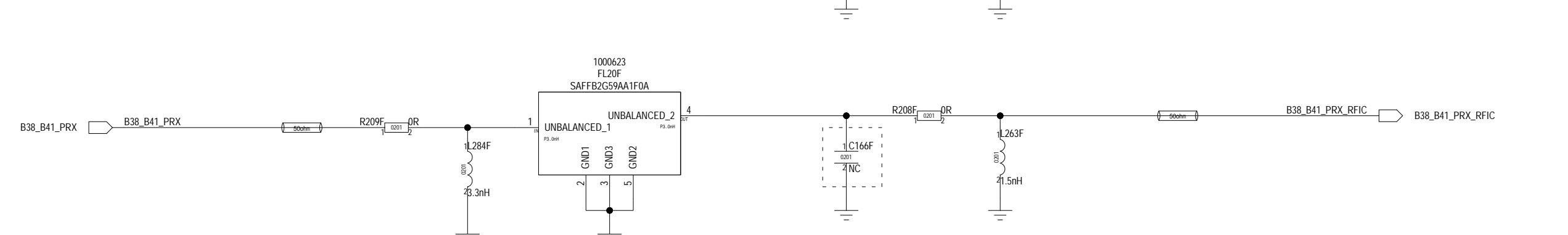
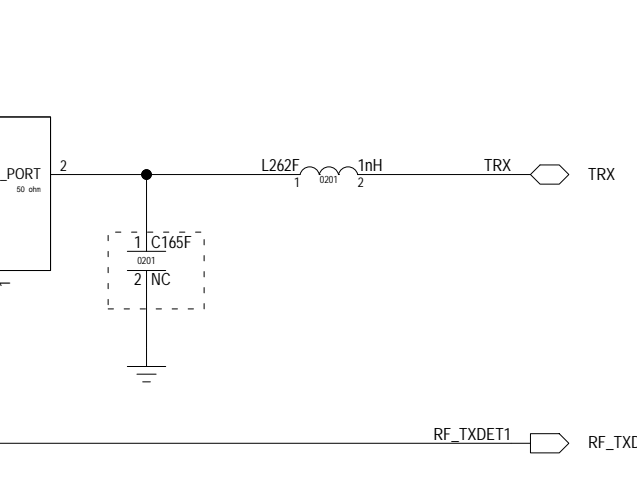
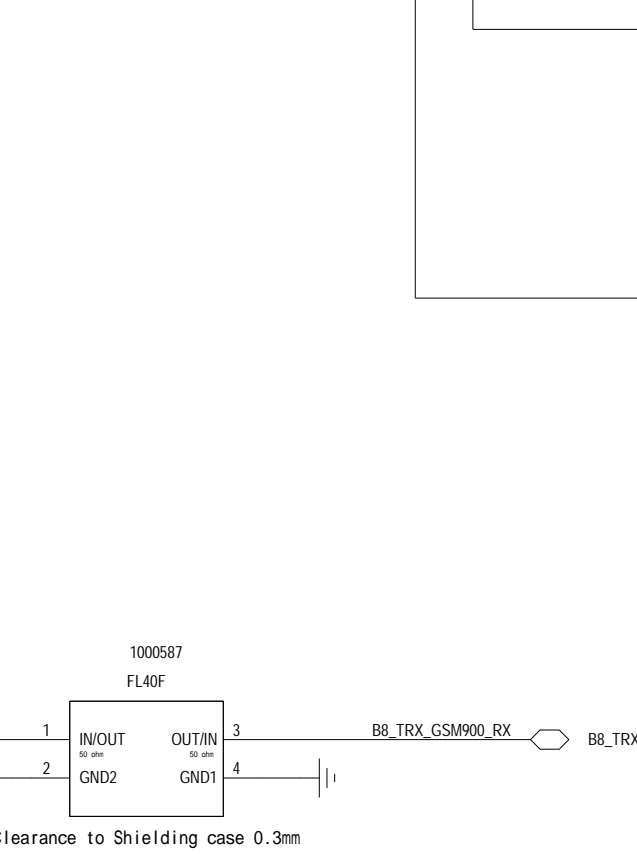
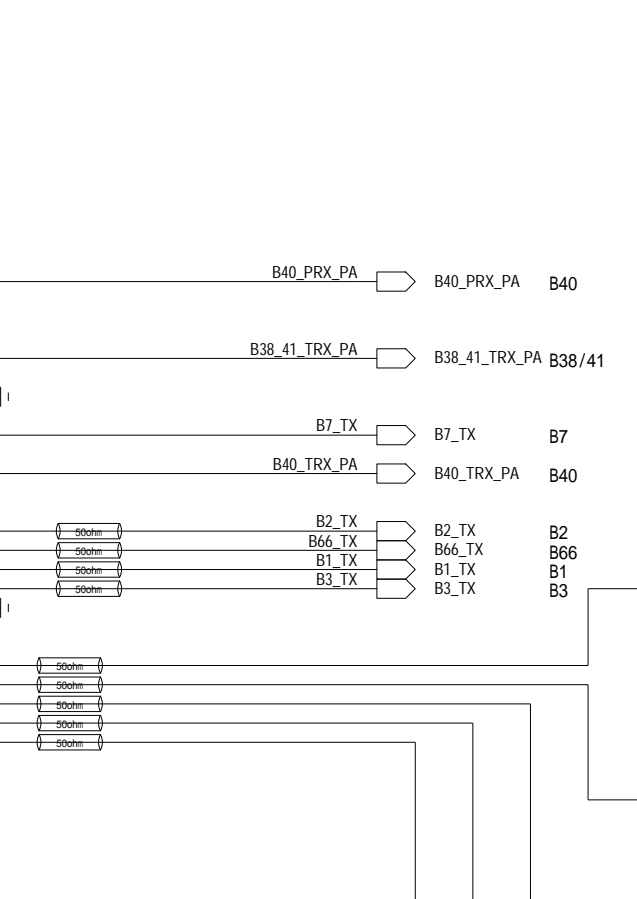
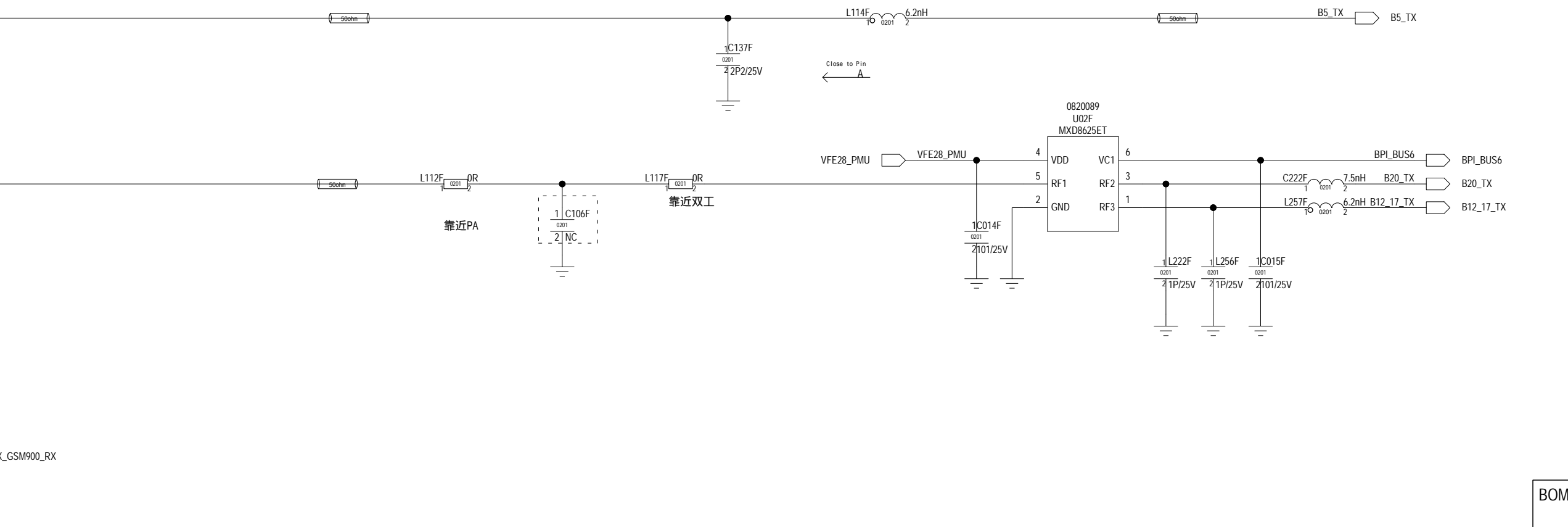
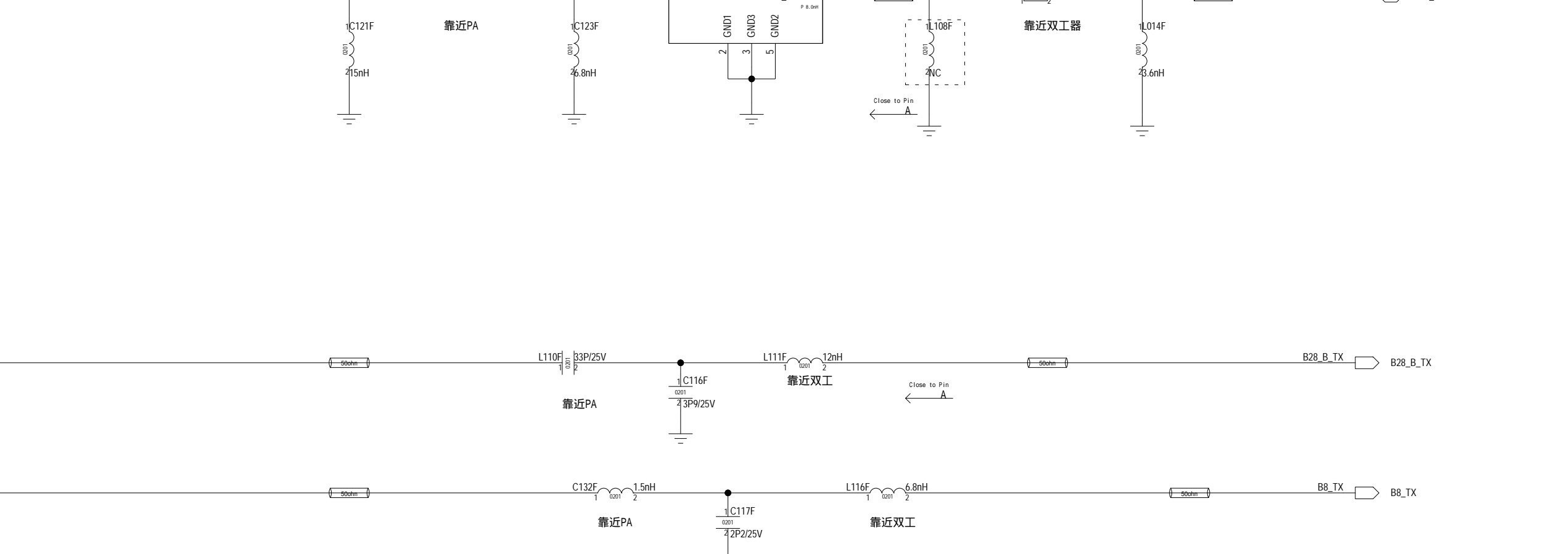
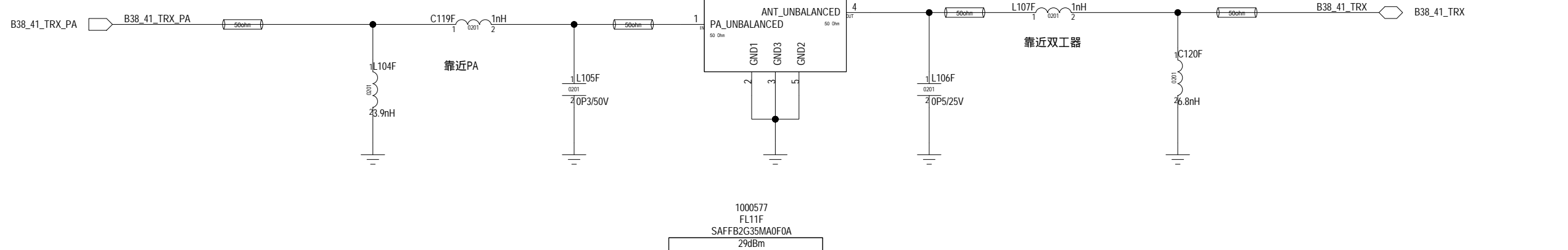
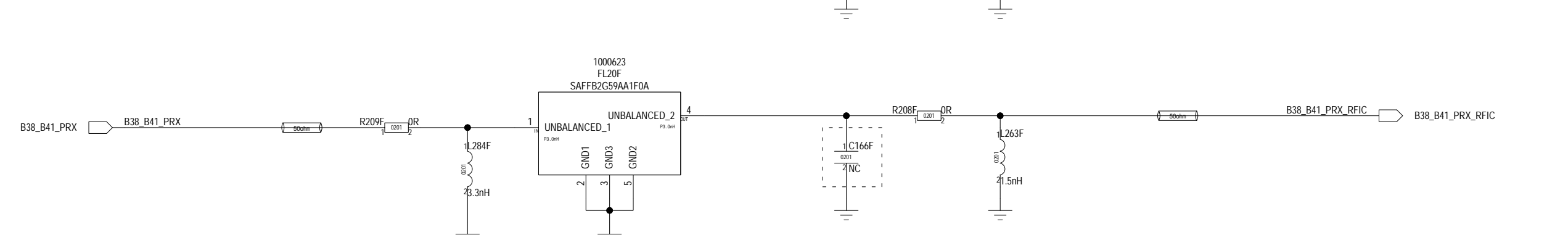
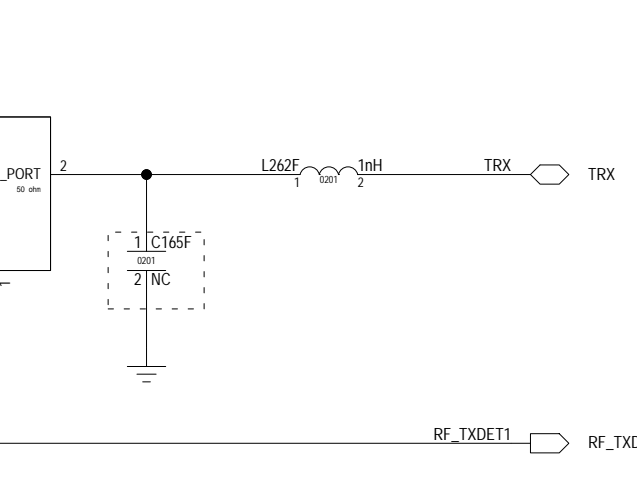
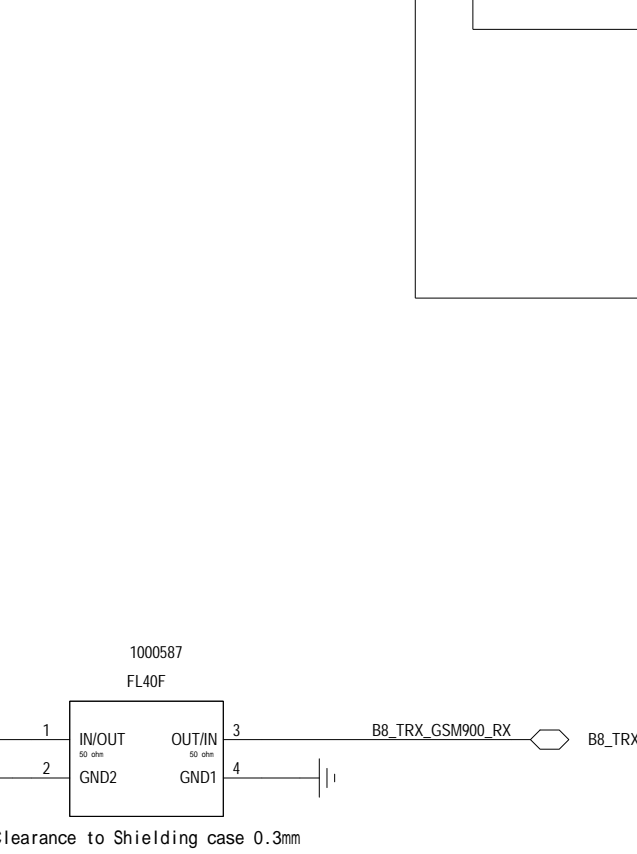
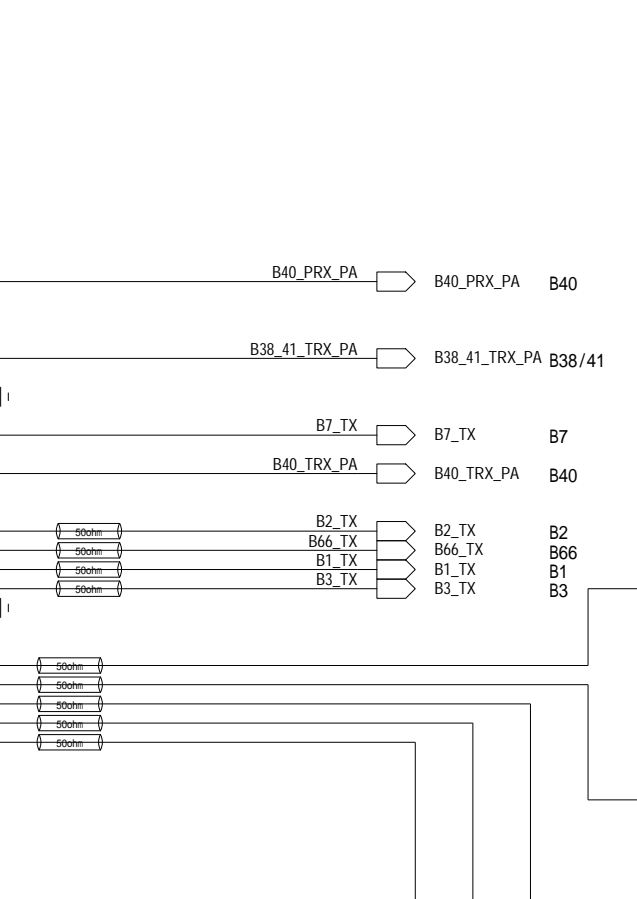
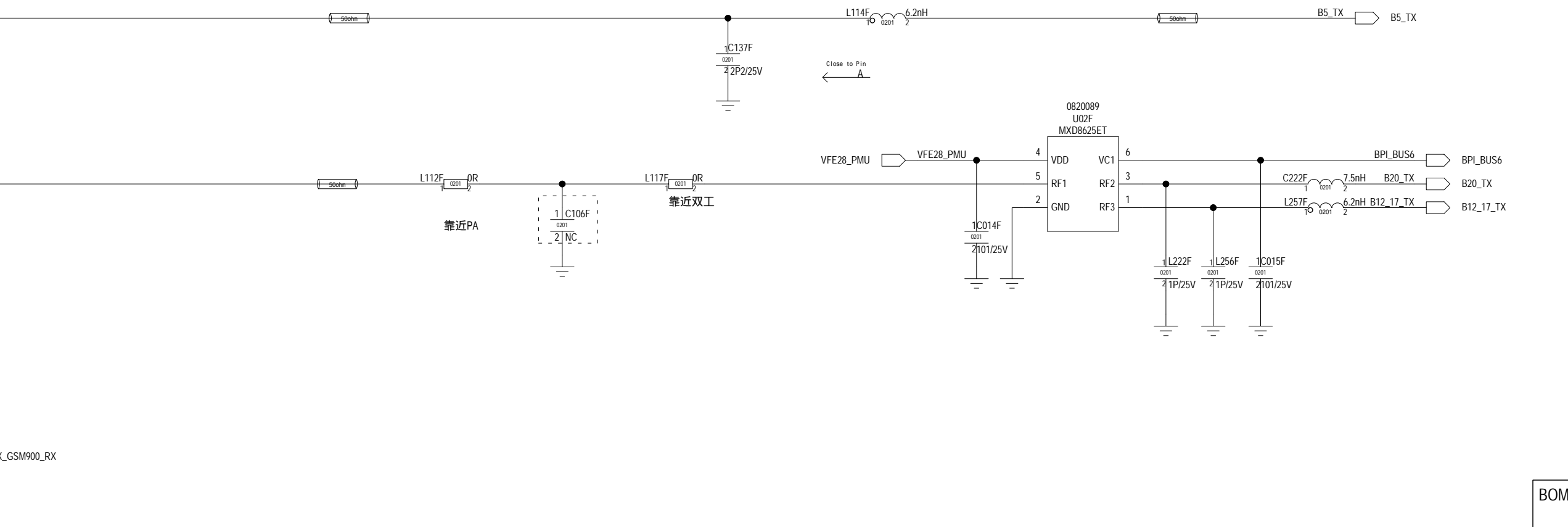
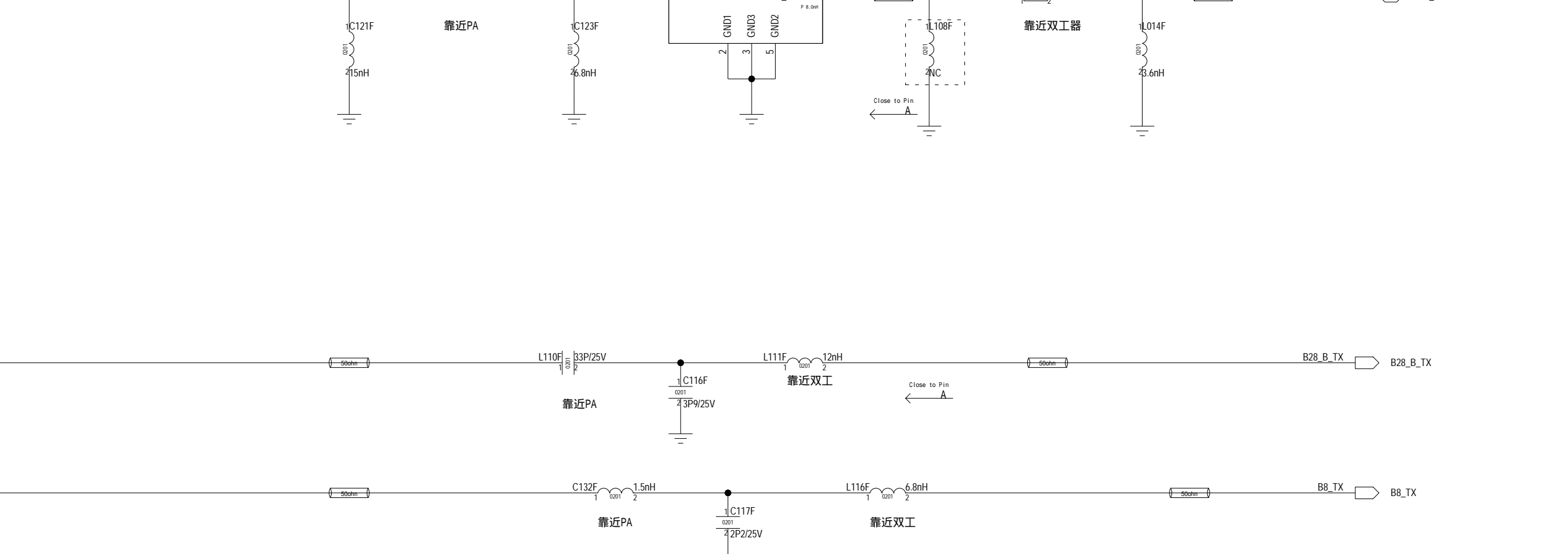
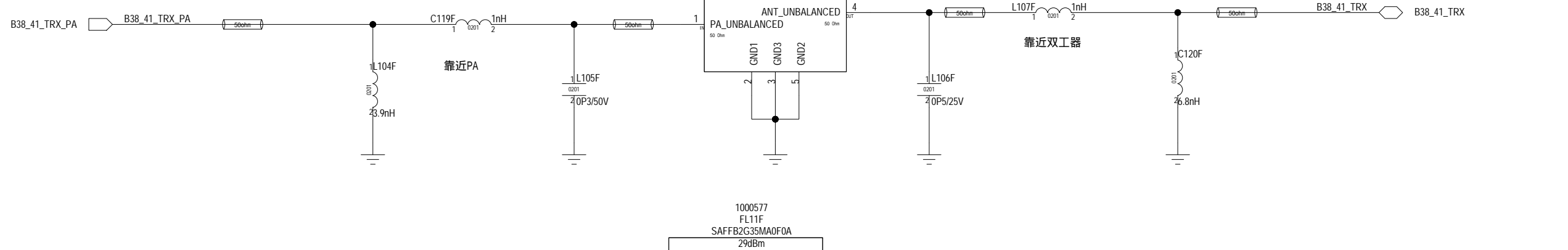
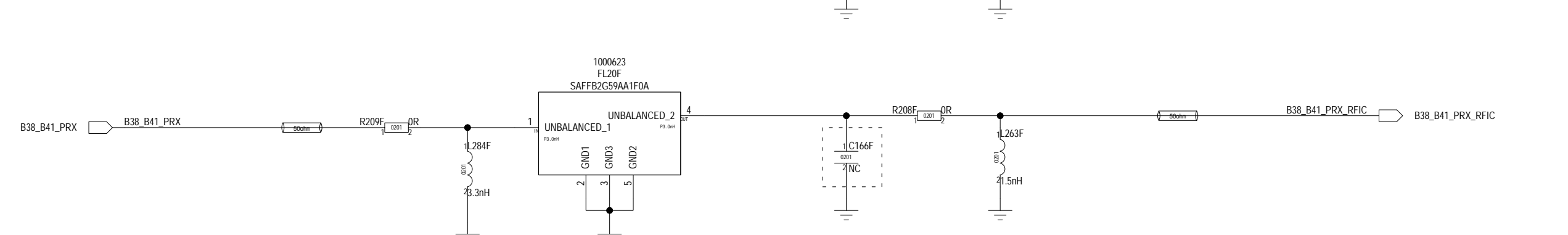
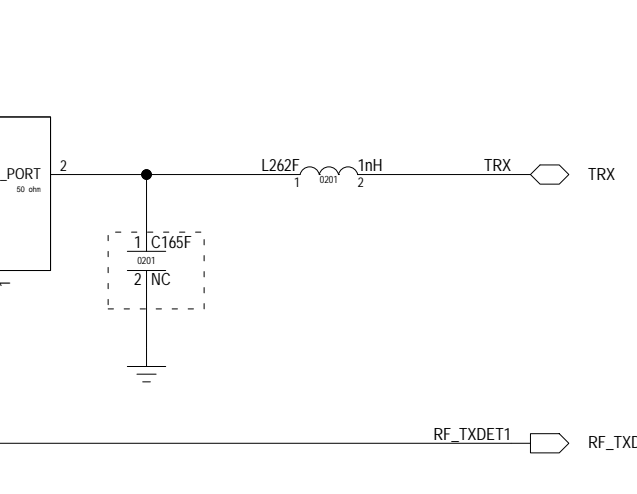
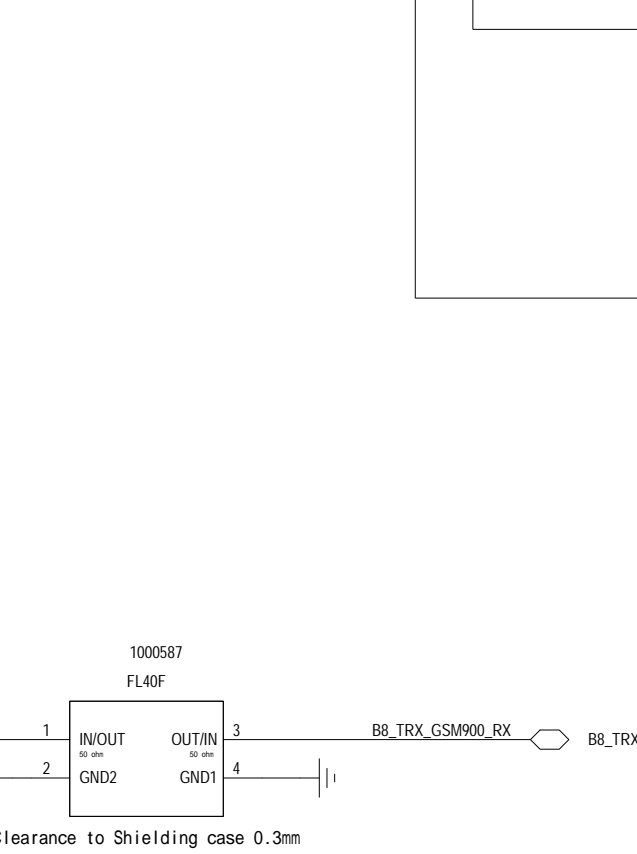
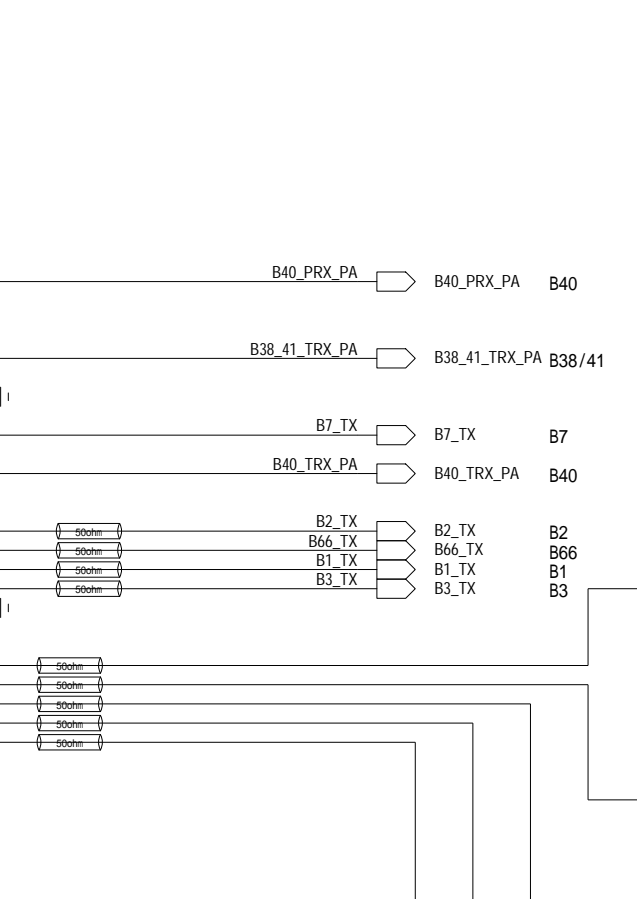
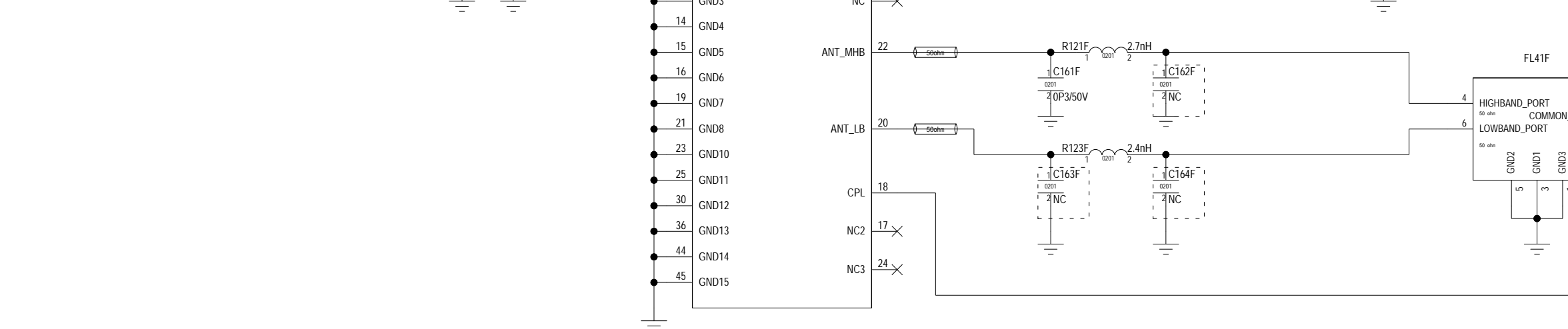
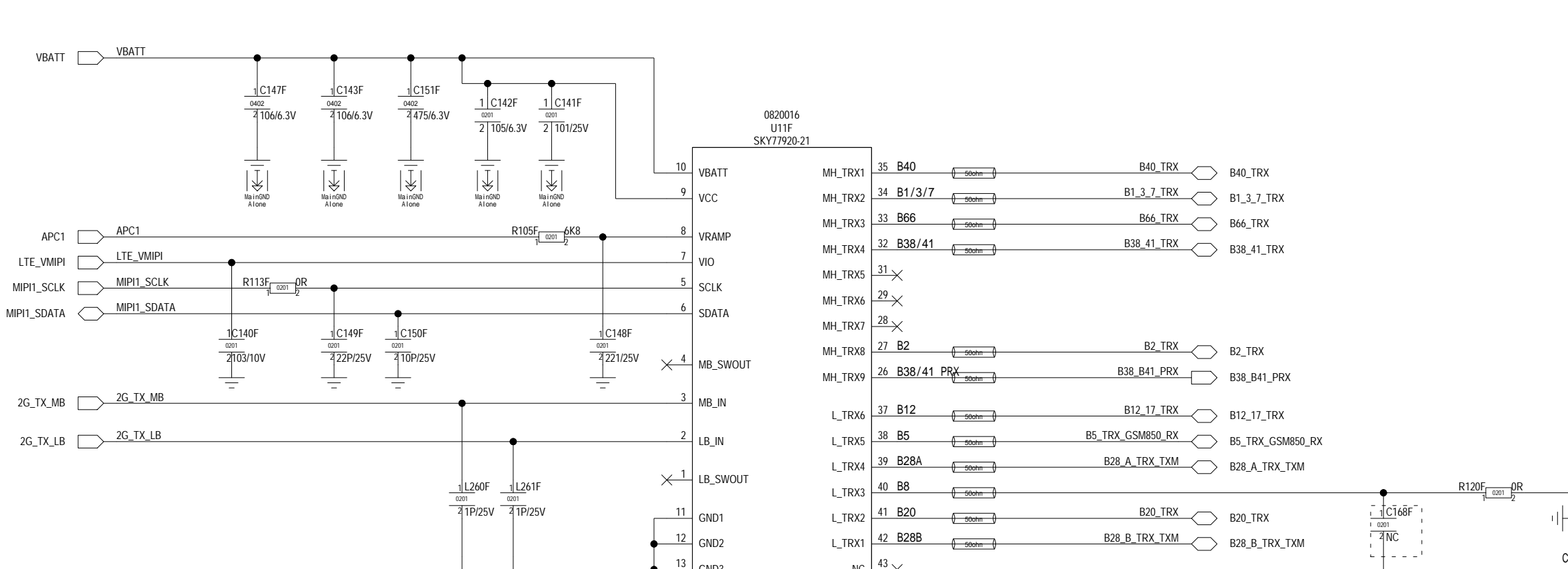
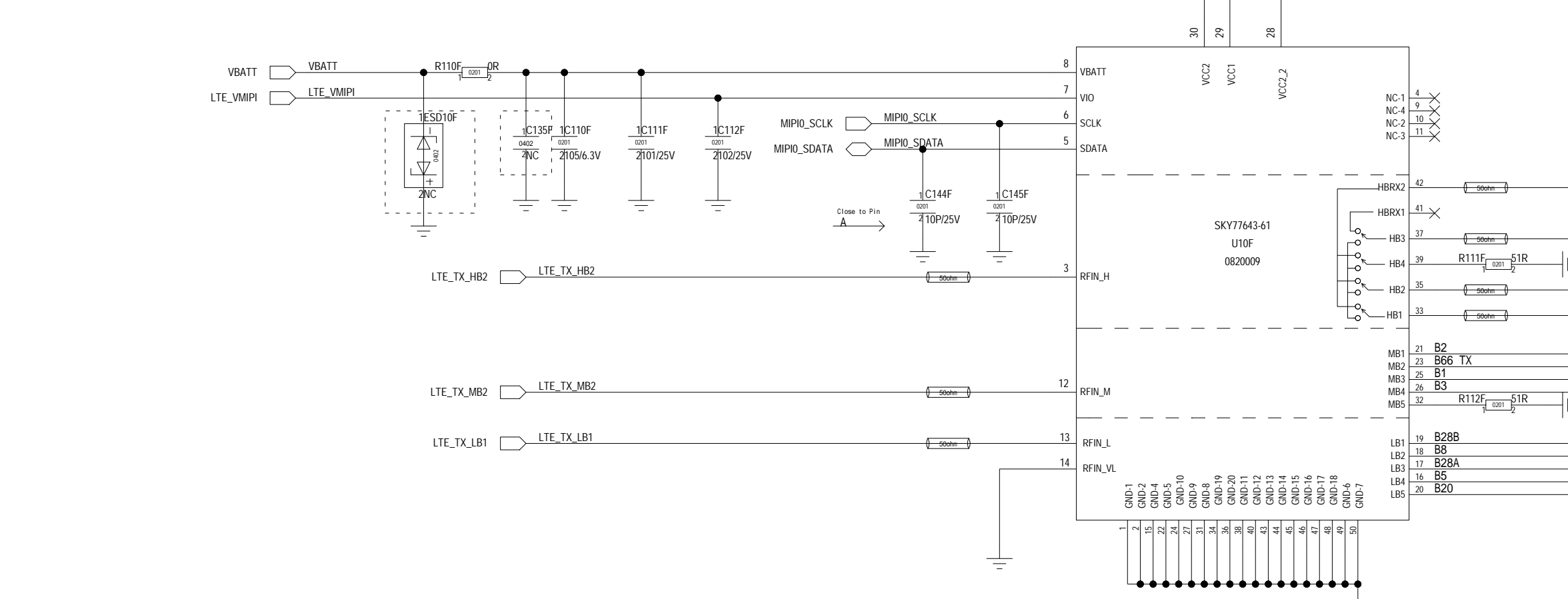
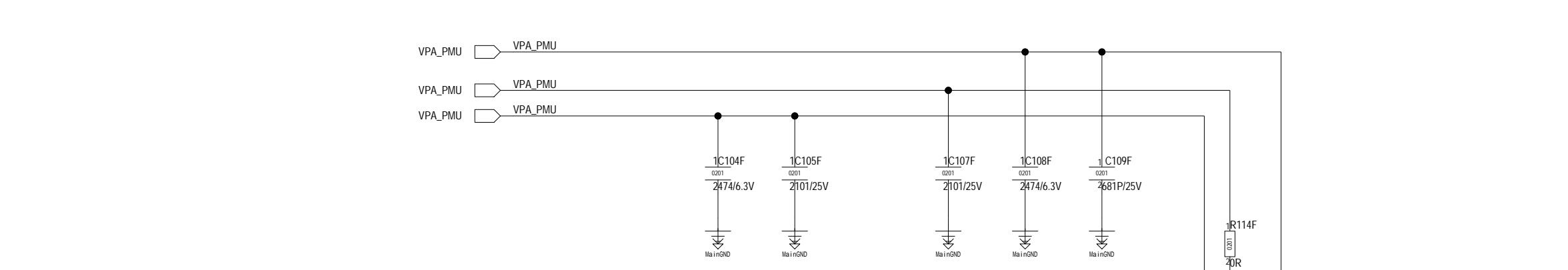
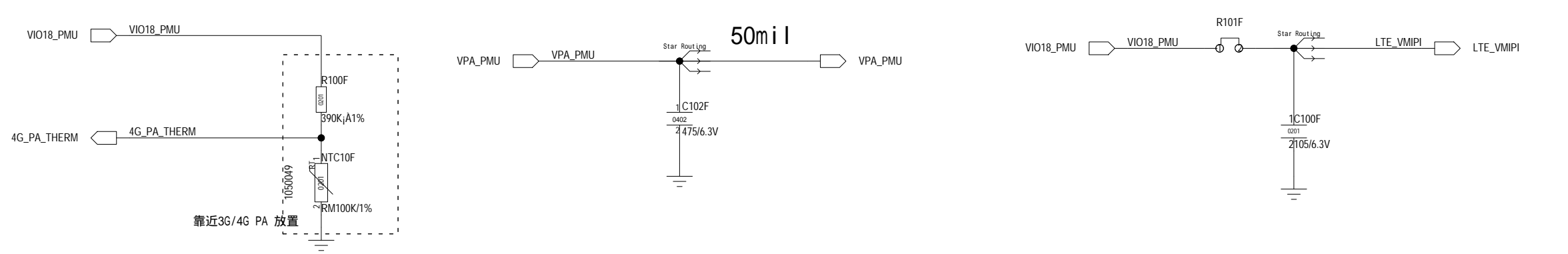

BOM\_VAR\_Name  
 \${VAR\_NAME}  
 BOM\_VAR\_Description  
 \${VAR\_DESC}

Company  
**vivo**  
 PlatForm  
 MT6769V/CT  
 Project  
 PD2103BF/DF  
 Sheet Name  
 MT6177\_TR  
 Size  
 A1  
 Rev  
 -0  
 Drawn By  
 DingSong  
 Page  
 20 of 27  
 17/06/2021:12:00



BOM\_VAR\_Name  
\${VAR\_NAME}

BOM\_VAR\_Description  
\${VAR\_DESC}

Company  
**vivo**

Platform  
MT6769V/CT

Project  
PD2103BF/DF

Sheet Name  
2G\_3G\_4G\_TX

Size  
A1

Rev  
-0

Drawn By  
DingSong

Page  
21 of 27

17/06/2021:12:00

H

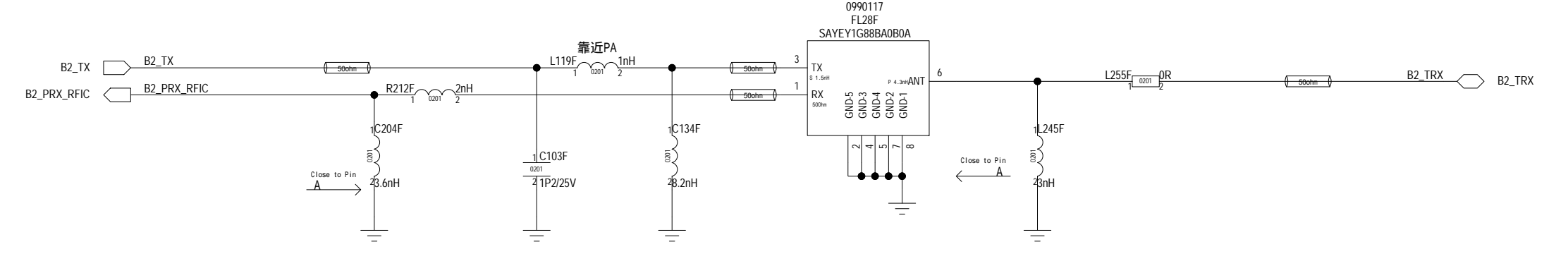
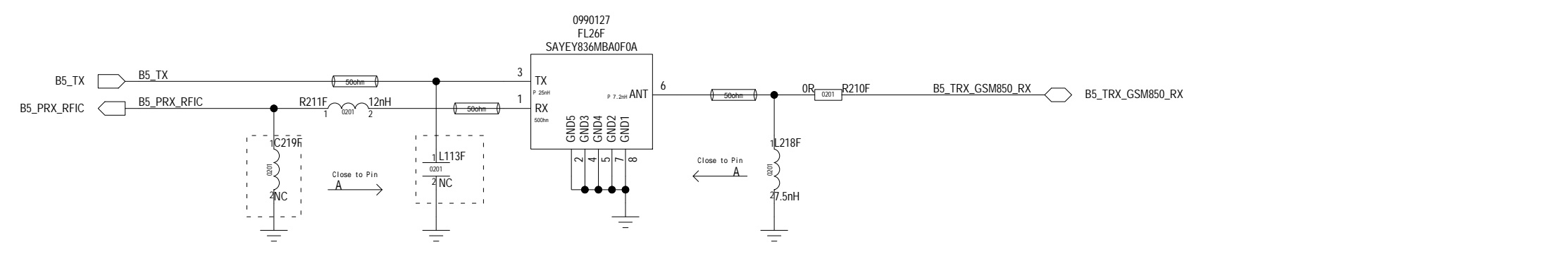

H

G

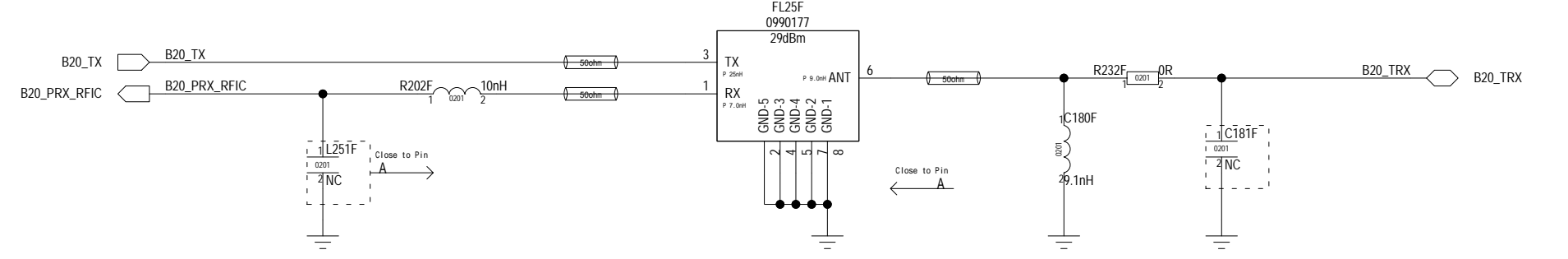
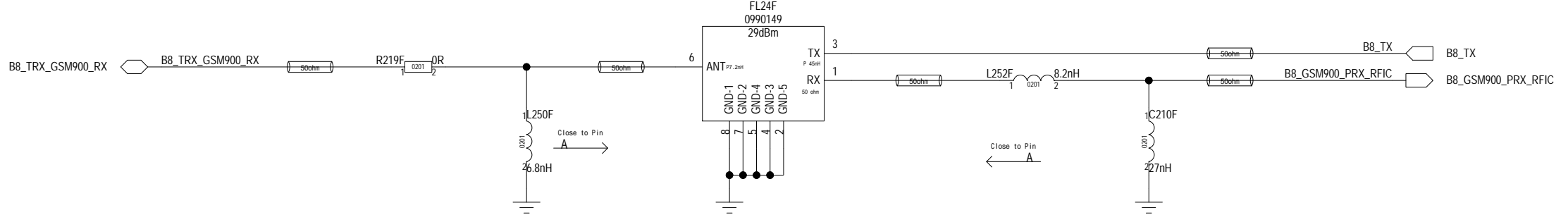

G

F

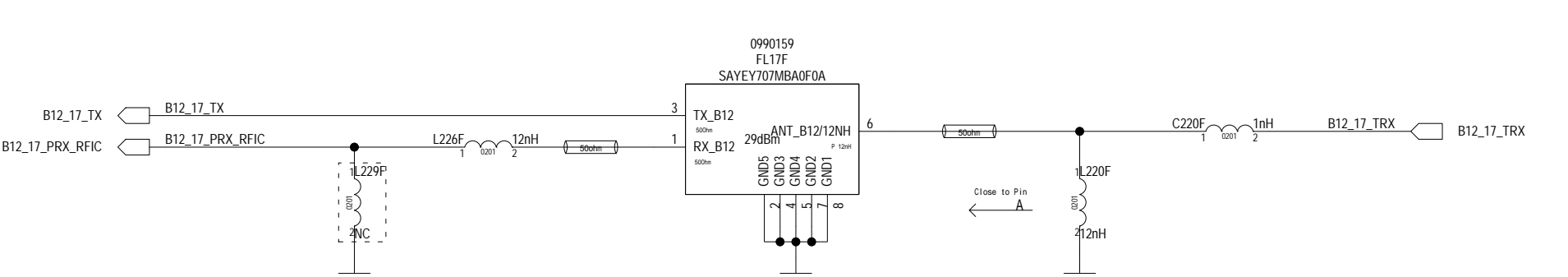
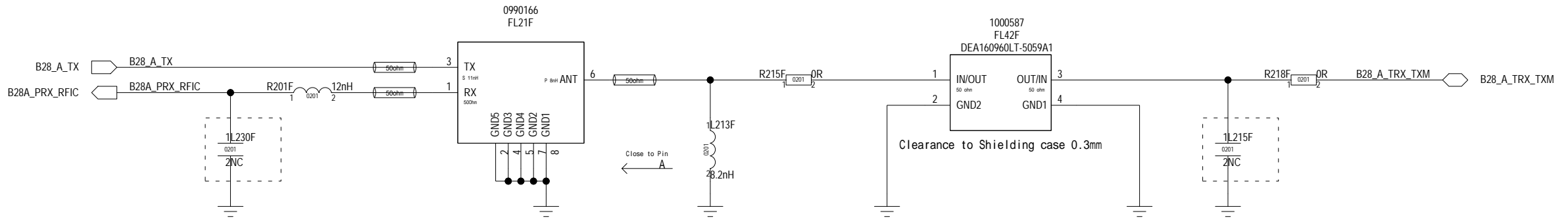

F

E

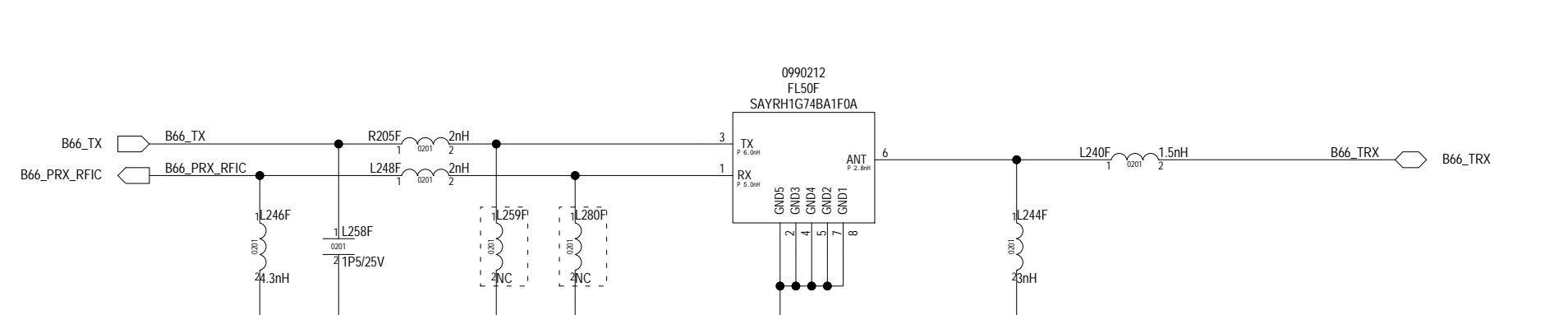
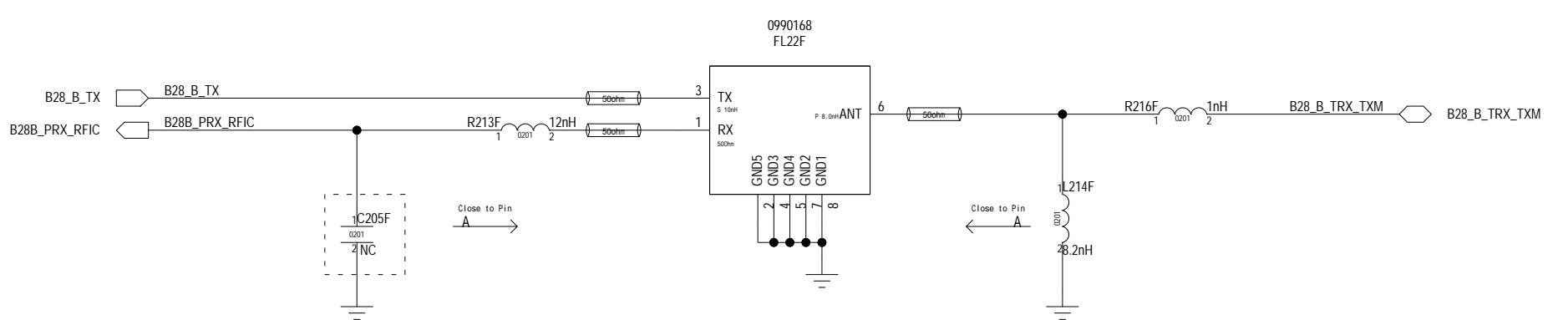

E

D

C

B

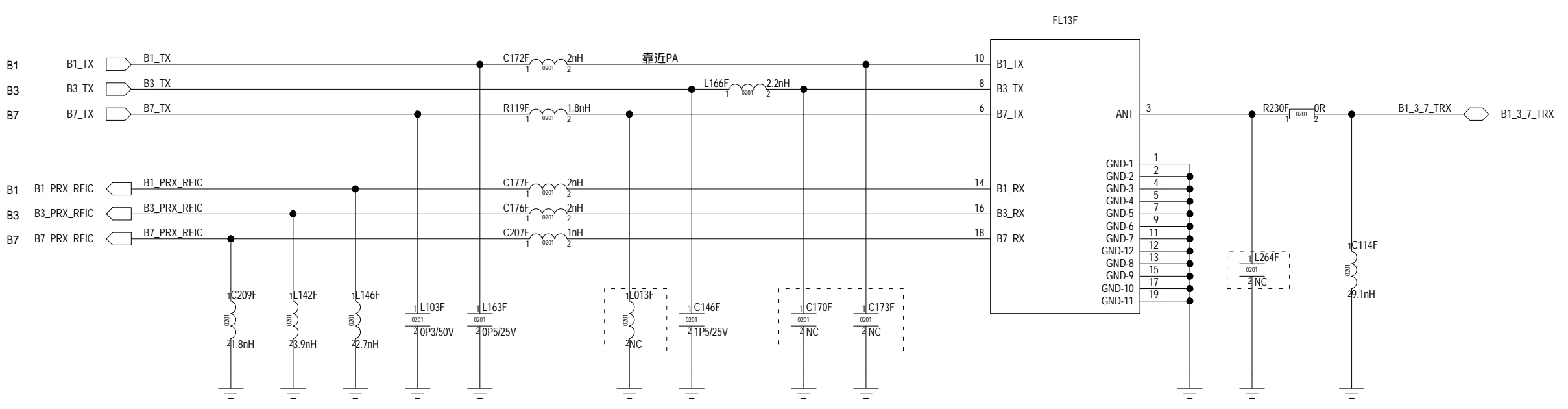

BOM_VAR_Name		\${VAR_NAME}	
BOM_VAR_Description		\${VAR_DESC}	
Company		<b>vivo</b>	
PlatForm	MT6769V/CT	Project	PD2103BF/DF
Sheet Name	PRX	Size	A1
		Rev	-0
Drawn By	DingSong	Page	22 of 27
			17/06/2021:12:01

B

C

D

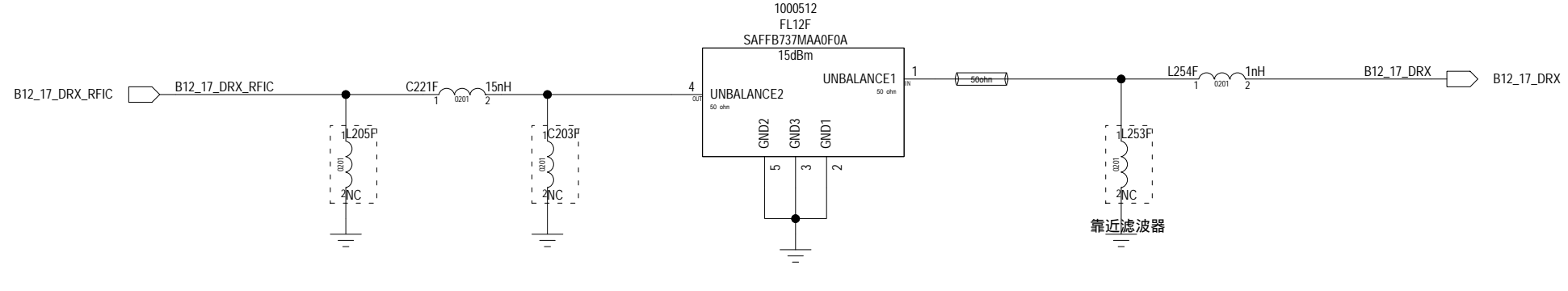
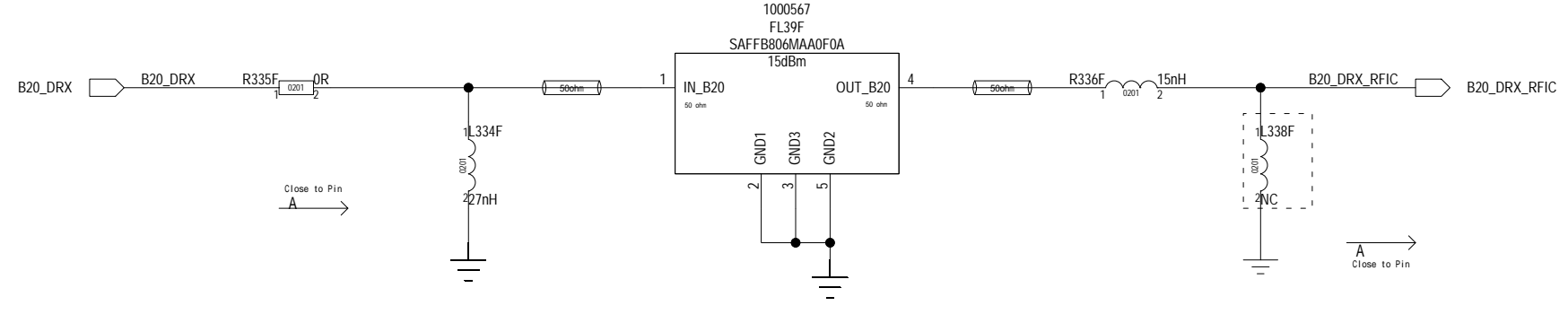
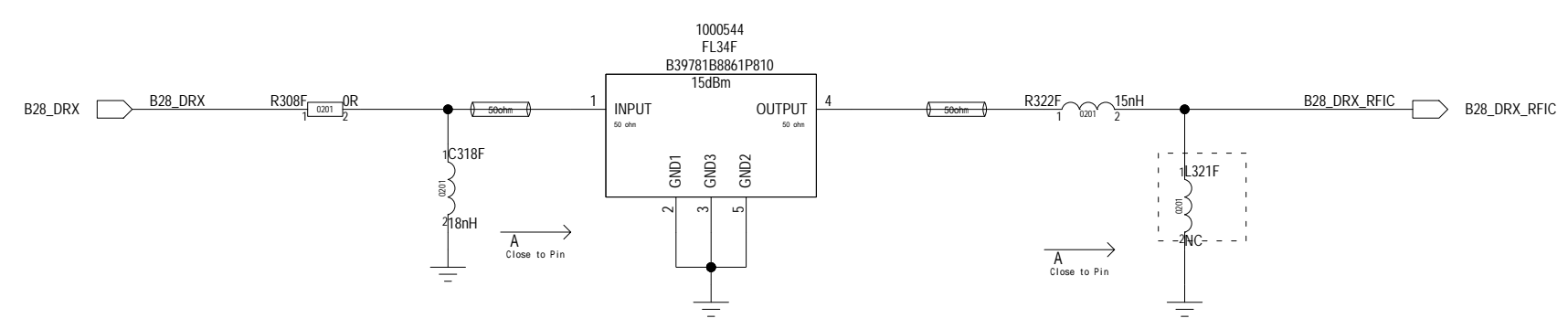
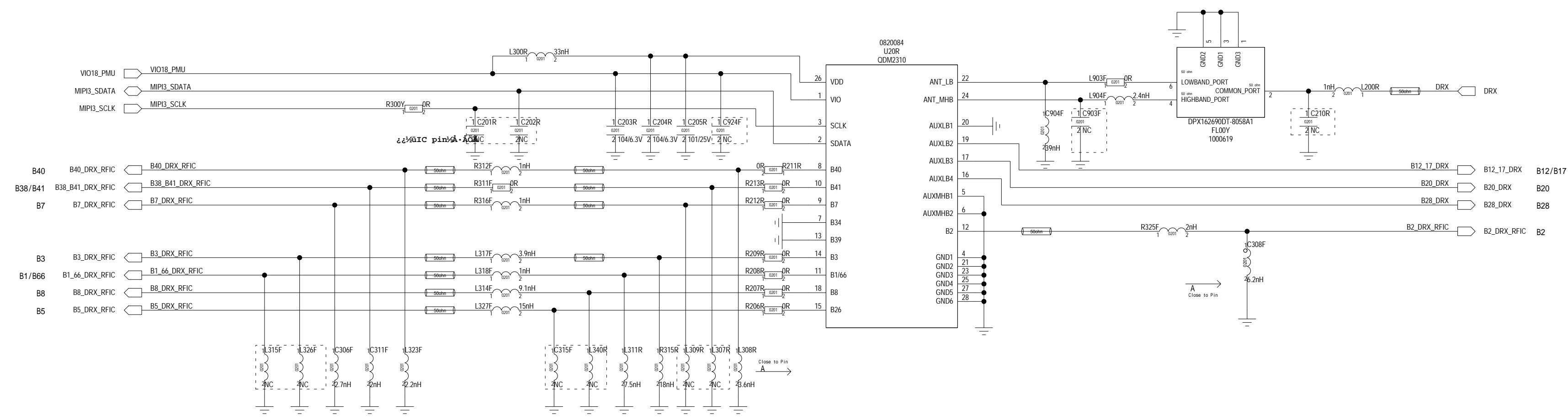

BOM_VAR_Name \${VAR_NAME}	
BOM_VAR_Description \${VAR_DESC}	
Company <b>vivo</b>	Project PD2103BF/DF
PlatForm MT6769V/CT	Sheet Name DRX
Size A1	Rev -0
Drawn By DingSong	Page 23 of 27
17/06/2021:12:01	

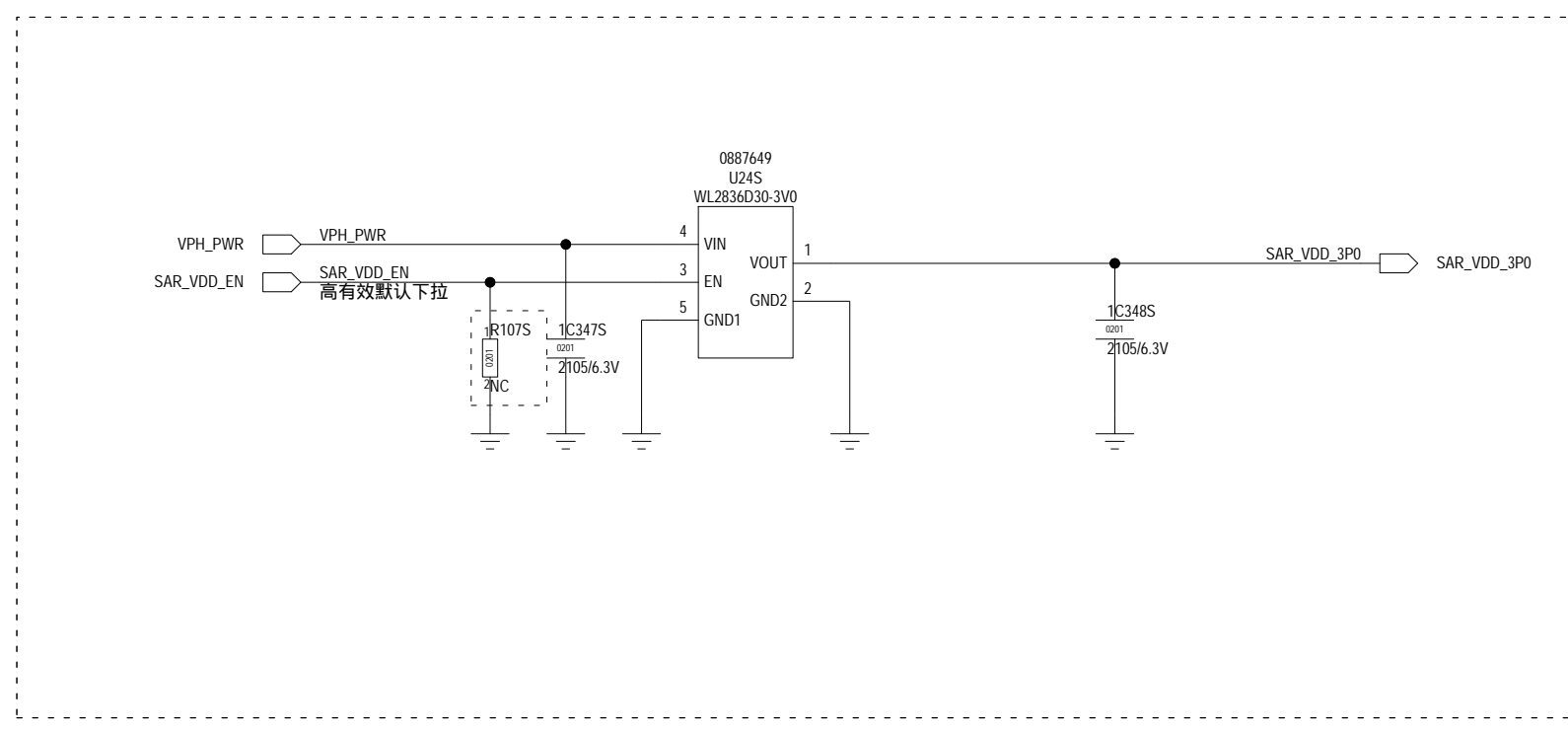
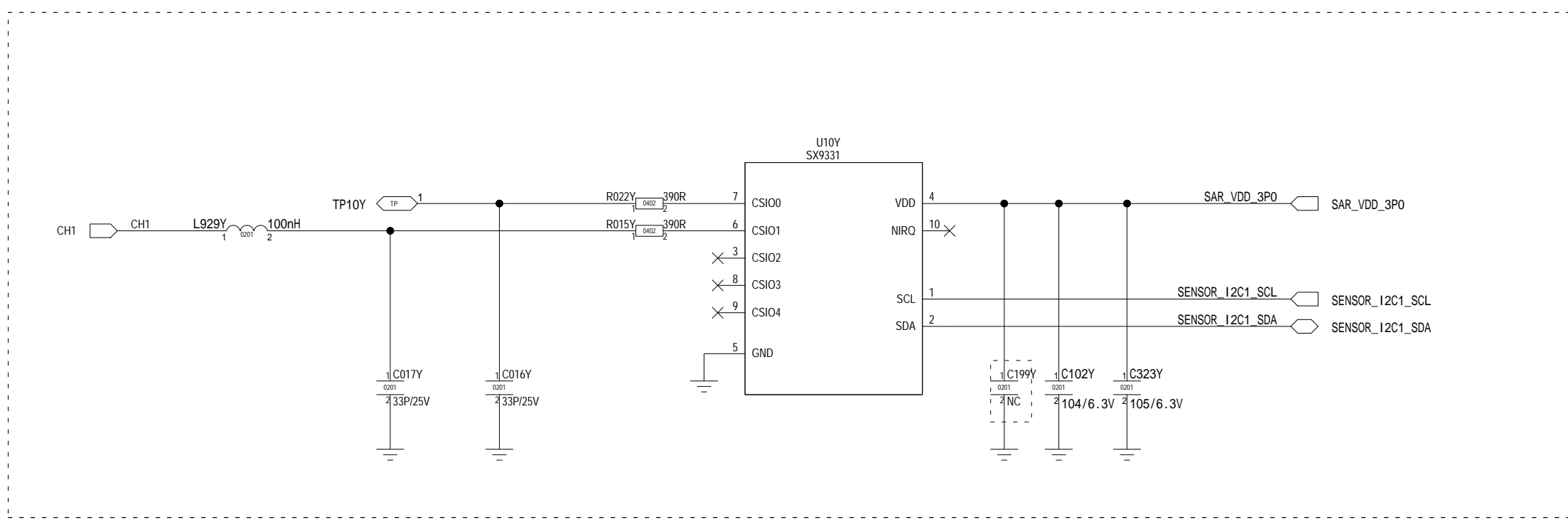
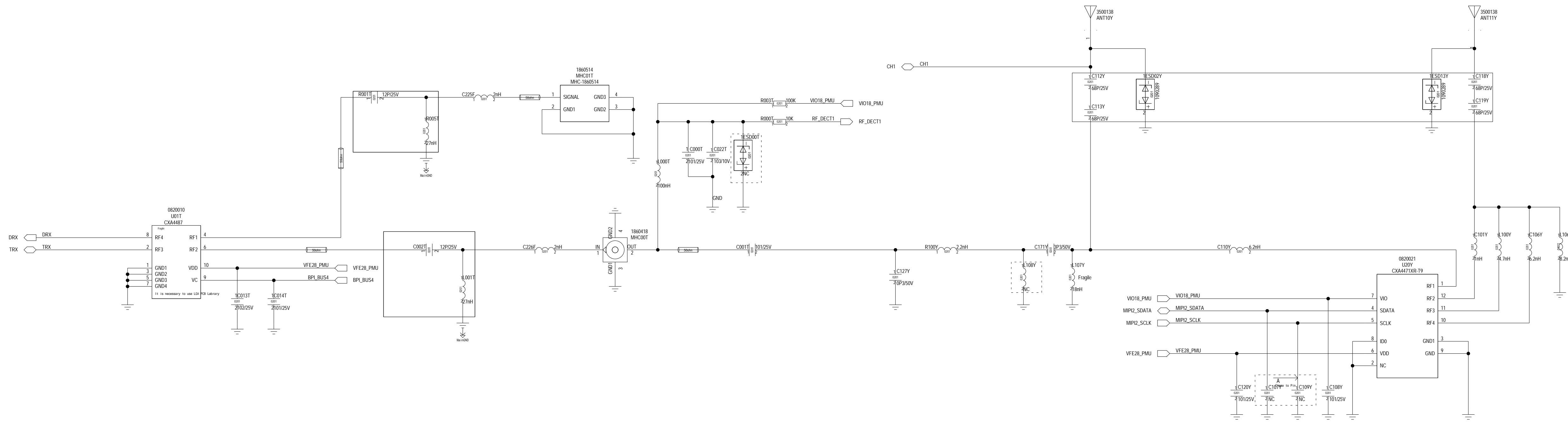

BOM\_VAR\_Name  
 \${VAR\_NAME}  
 BOM\_VAR\_Description  
 \${VAR\_DESC}

Company		<b>vivo</b>	
PlatForm	MT6769V/CT	Project	PD2103BF/DF
Sheet Name	ANT TUNER		Size A1
			Rev -0
Drawn By	DingSong	Page	24 of 27 17/06/2021:12:01



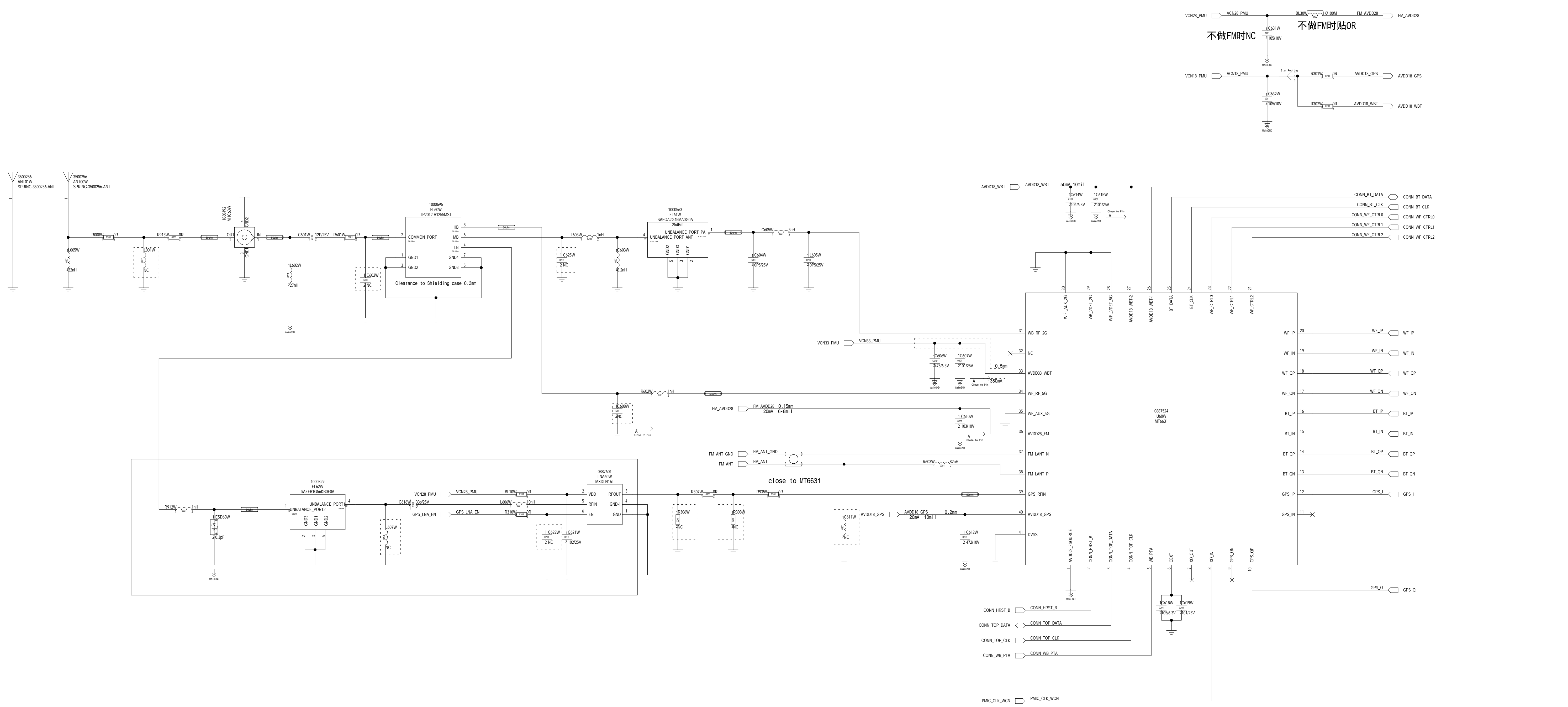

不做FIM时贴

close to MT6631

BOM\_VAR\_Name  
 \${VAR\_NAME}  
 BOM\_VAR\_Description  
 \${VAR\_DESC}

Company **vivo**

PlatForm **MT6769V/CT** Project **PD2103BF/DF**

Sheet Name **MT6631** Size **A1**  
 Rev **-0**

Drawn By **DingSong** Page **25 of 27** 17/06/2021:12:01

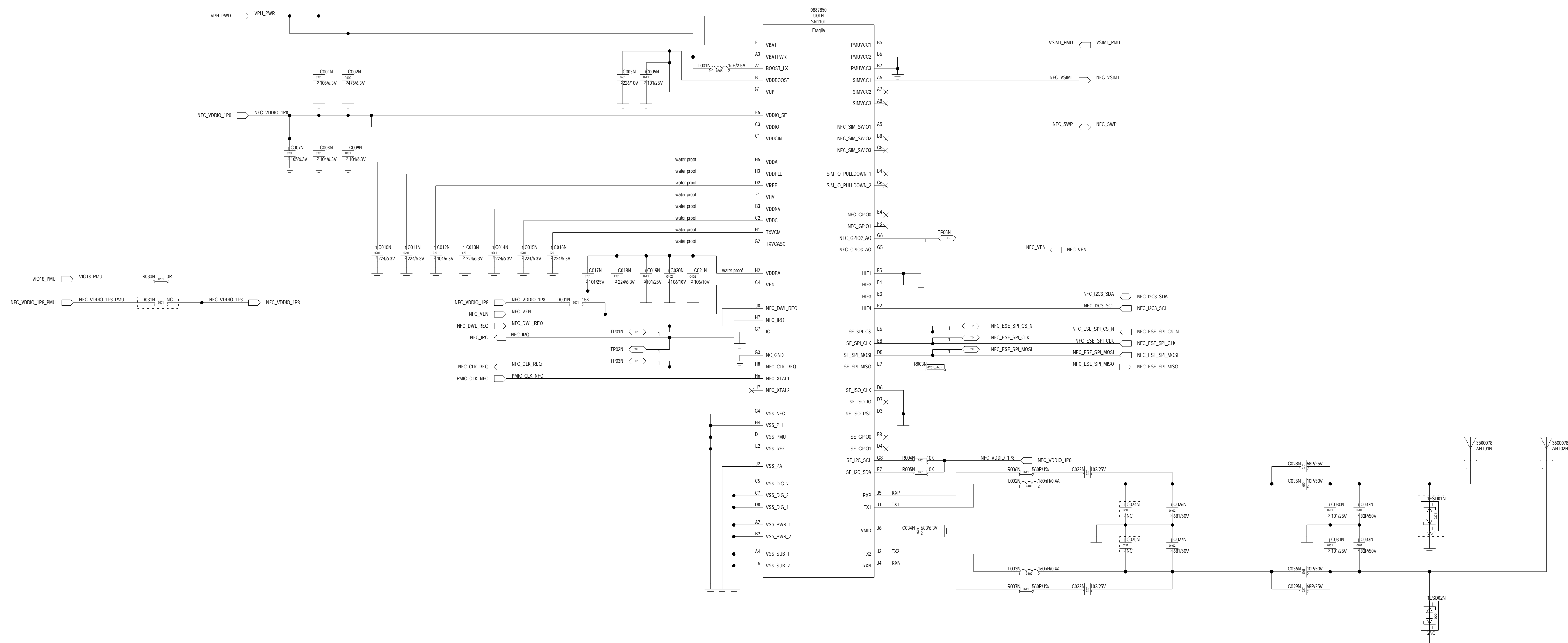

BOM\_VAR\_Name  
 \${VAR\_NAME}  
 BOM\_VAR\_Description  
 \${VAR\_DESC}

Company <b>vivo</b>	
PlatForm MT6769V/CT	Project PD2103BF/DF
Sheet Name NFC	Size A1 Rev -0
Drawn By DingSong	Page 26 of 27 17/06/2021:12:01

12

11

10

9

8

7

6

5

4

3

2

1

H

G

F

E

D

C

B

A

H

G

F

E

D

C

B

A

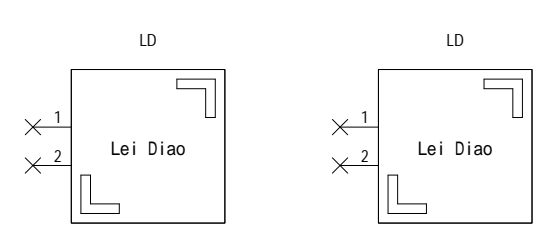
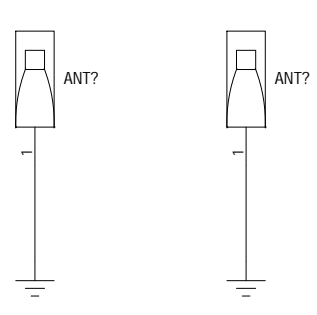
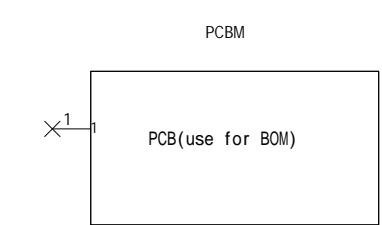
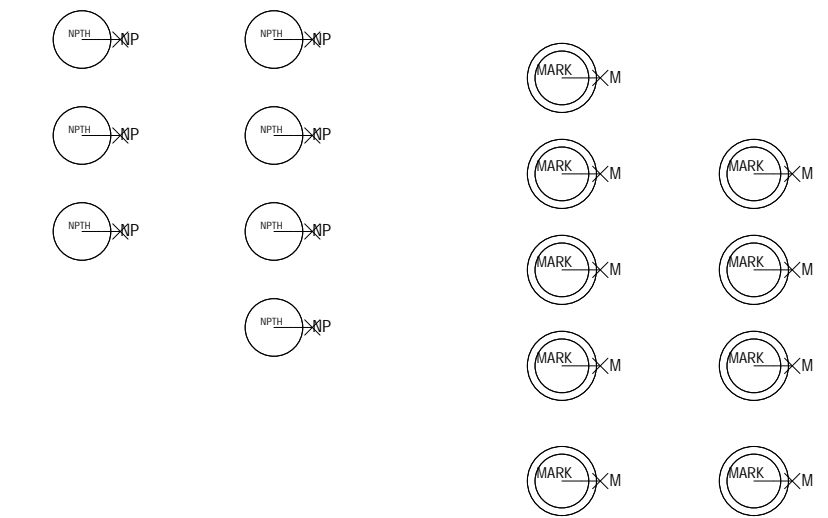
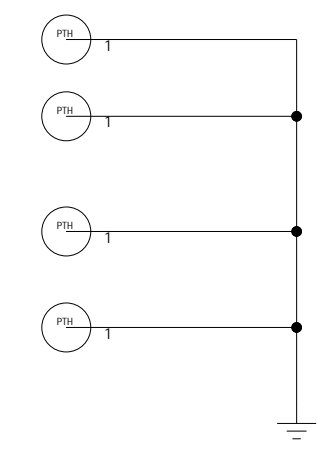
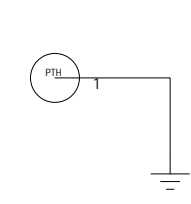
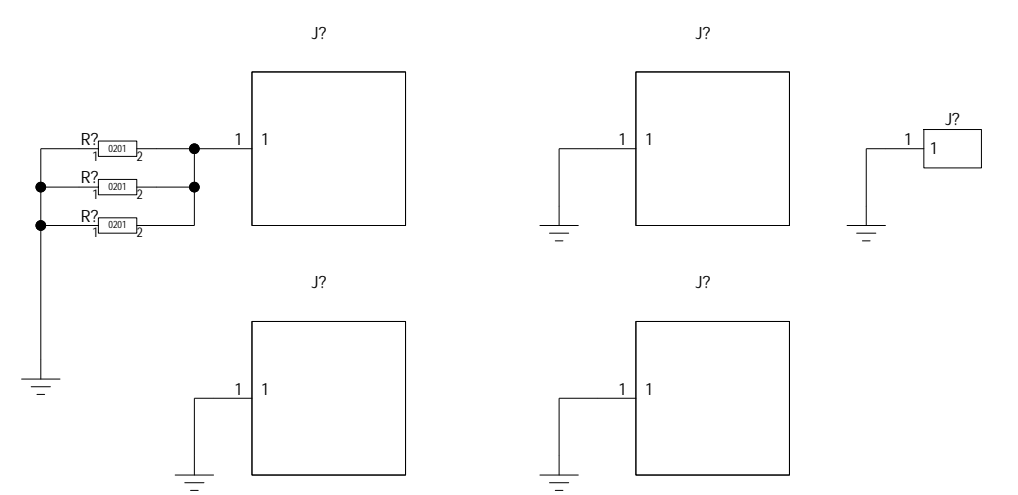
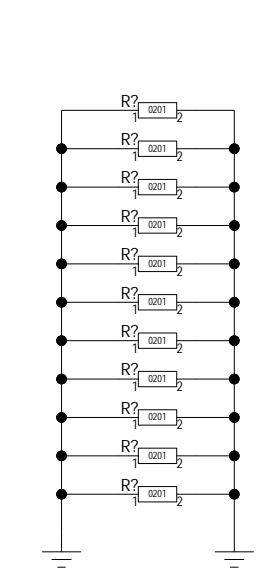
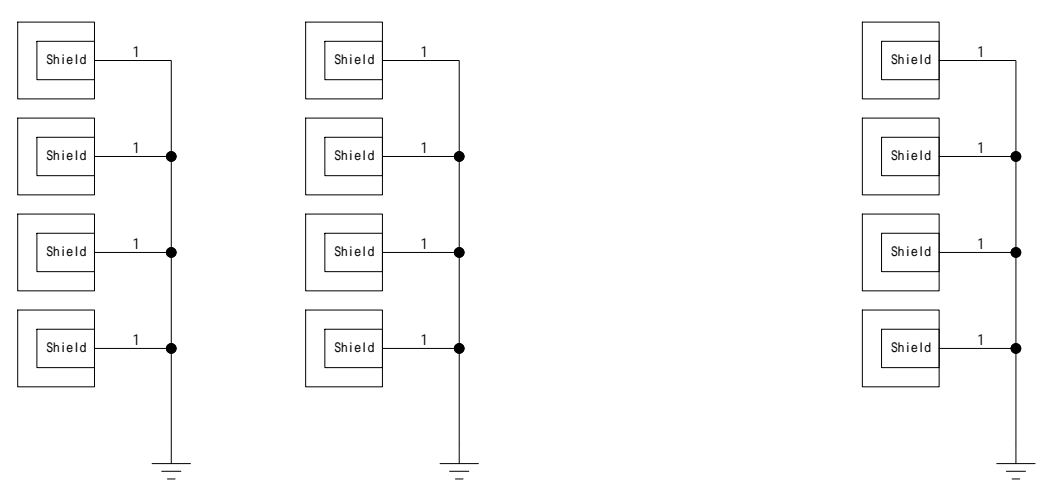
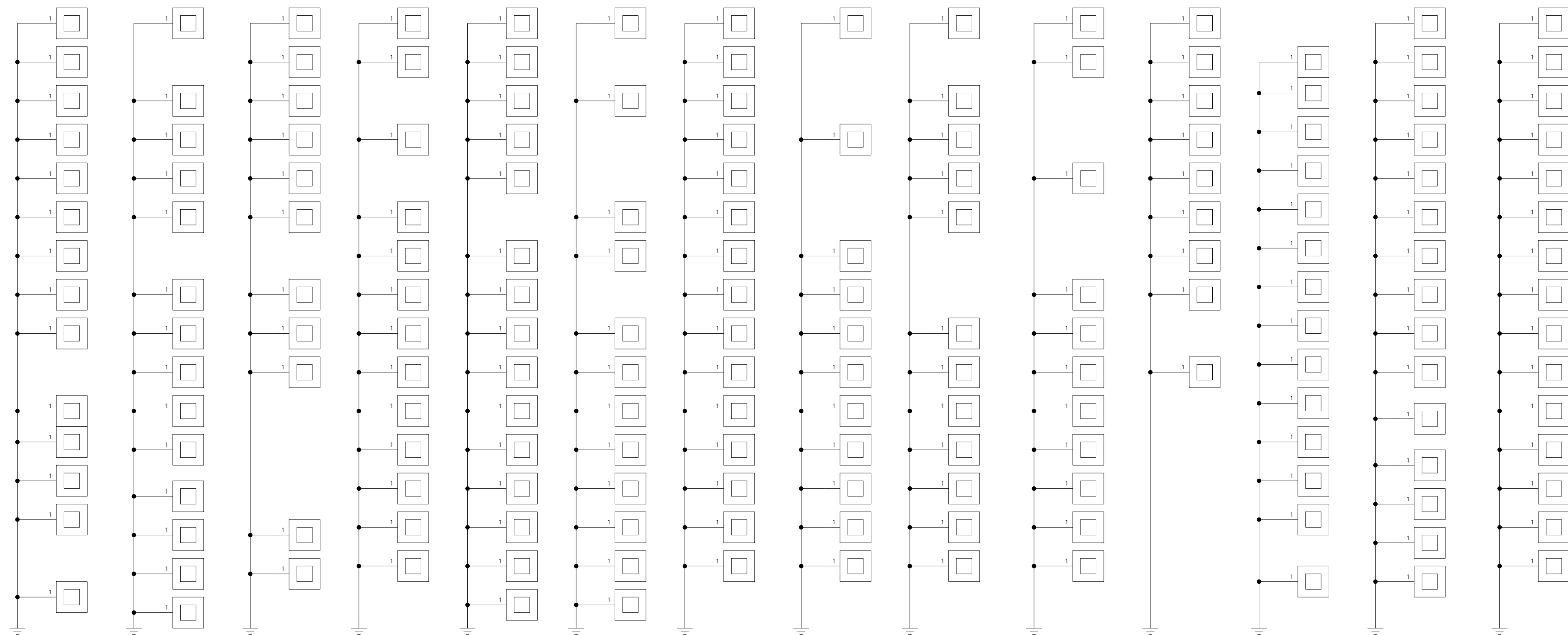
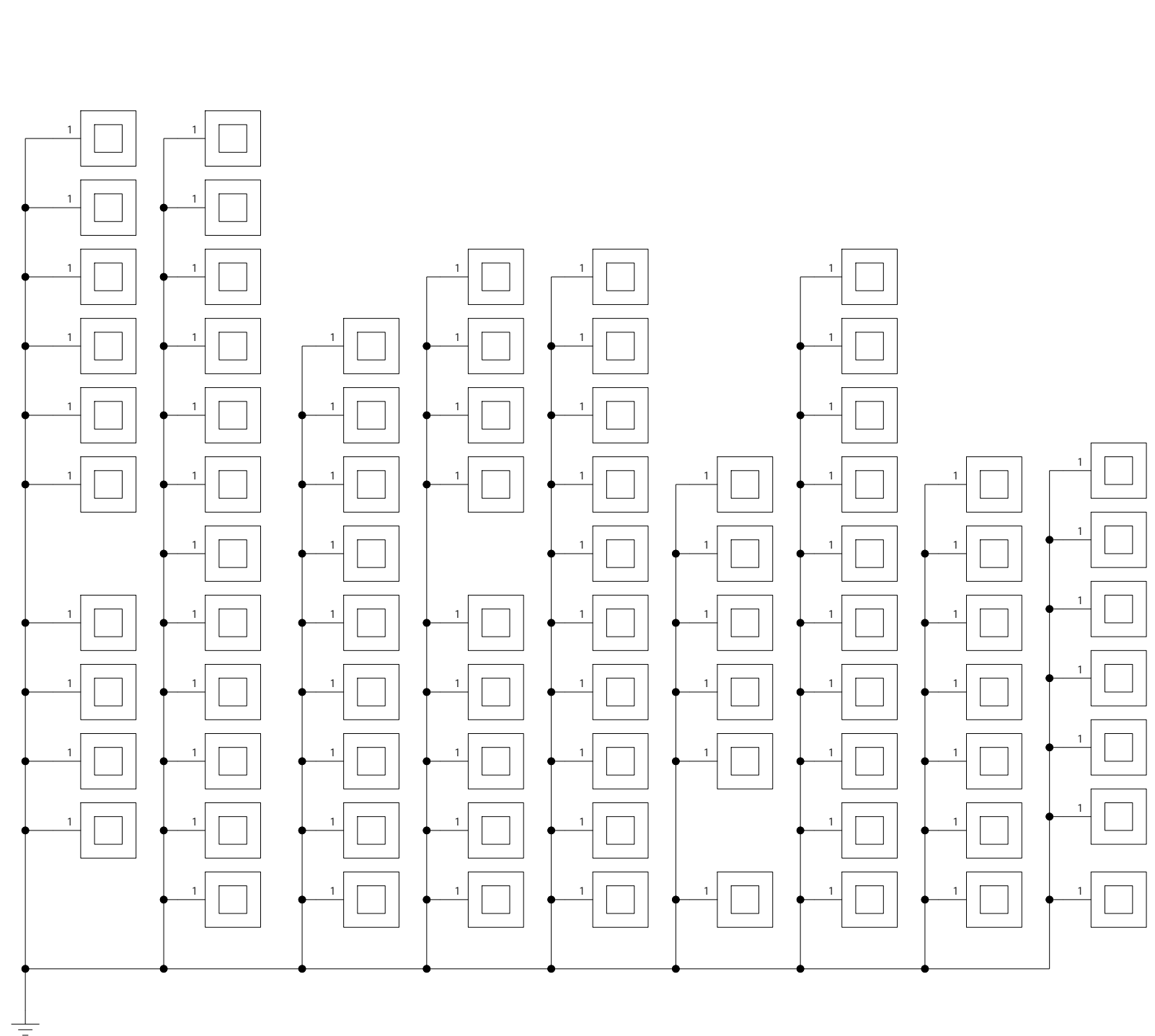

BOM_VAR_Name \${VAR_NAME}	
BOM_VAR_Description \${VAR_DESC}	
Company <b>vivo</b>	
PlatForm MT6769V/CT	Project PD2103BF/DF
Sheet Name SHIELD	Size A1 Rev -0
Drawn By DingSong	Page 27 of 27 17/06/2021:12:02

12

11

10

9

8

7

6

5

4

3

2

1

12

11

10

9

8

7

6

5

4

3

2

1

H

H

G

G

F

F

E

E

D

D

C

C

B

B

A

A

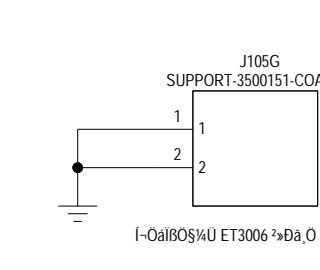
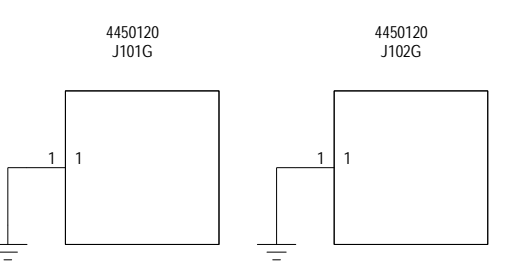
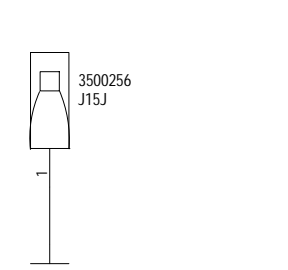
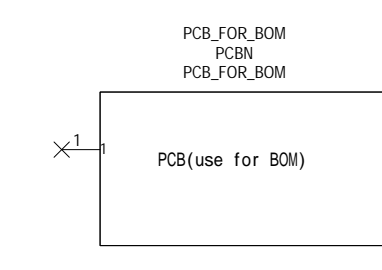
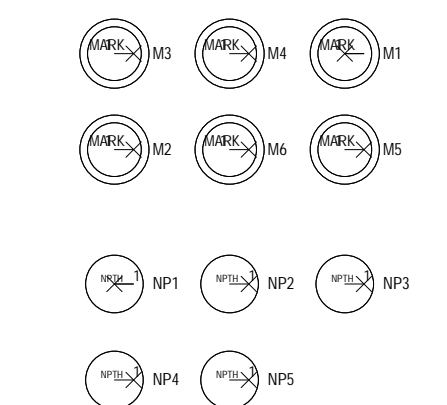
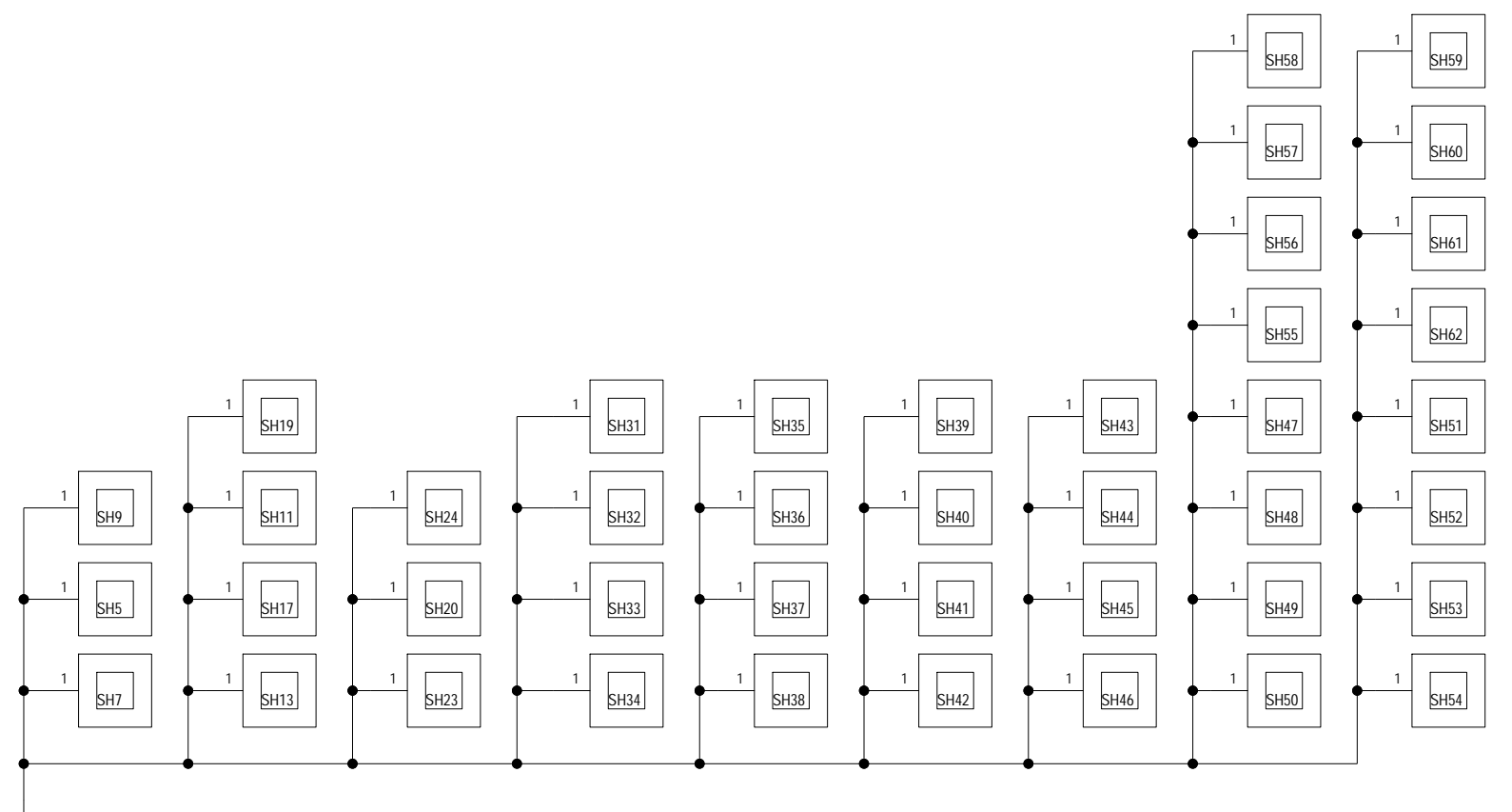
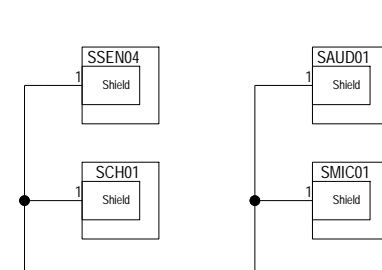
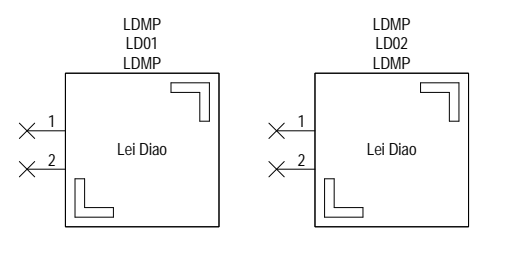
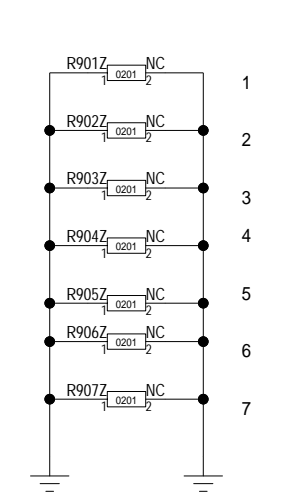
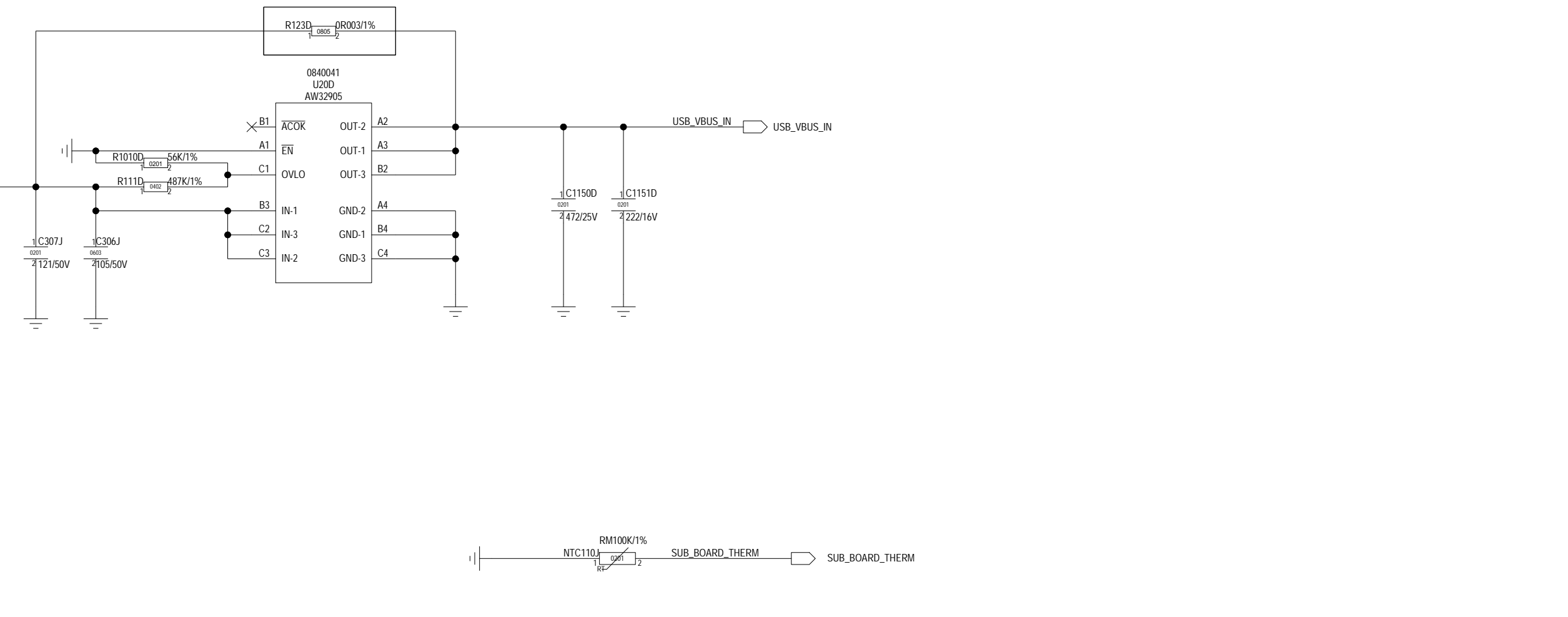
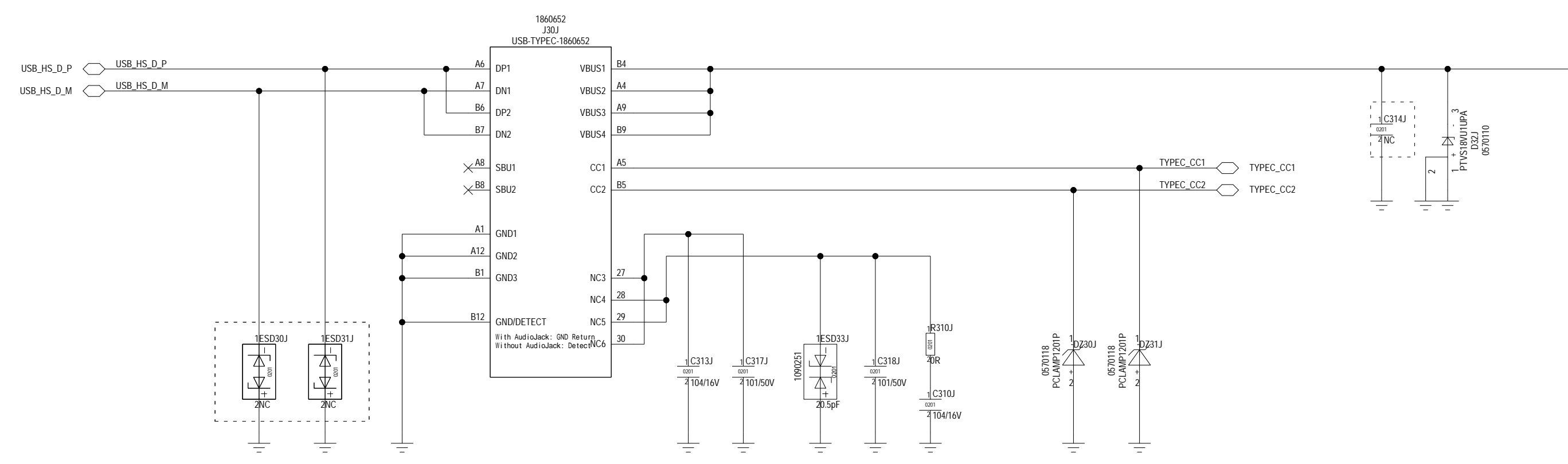
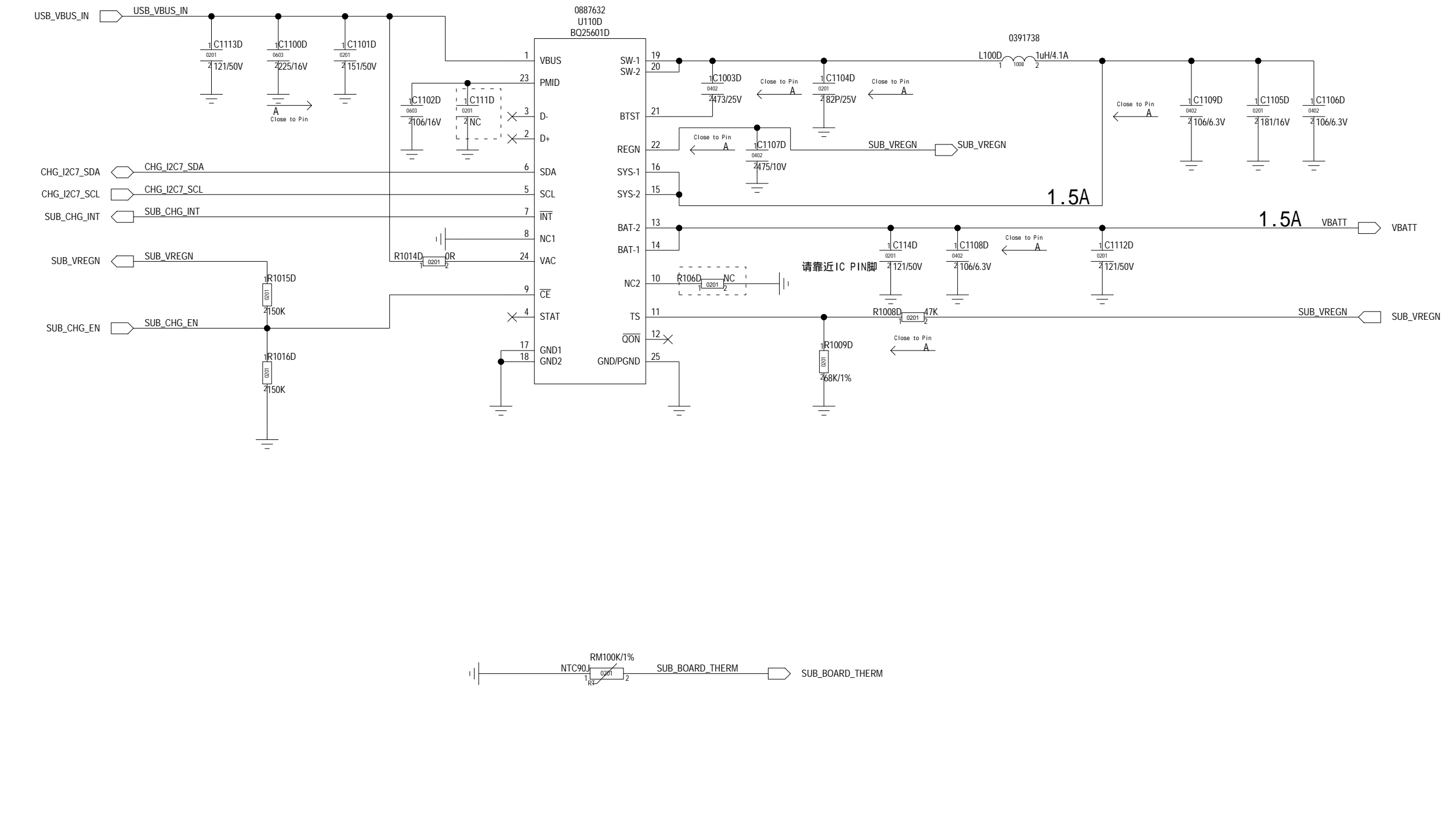
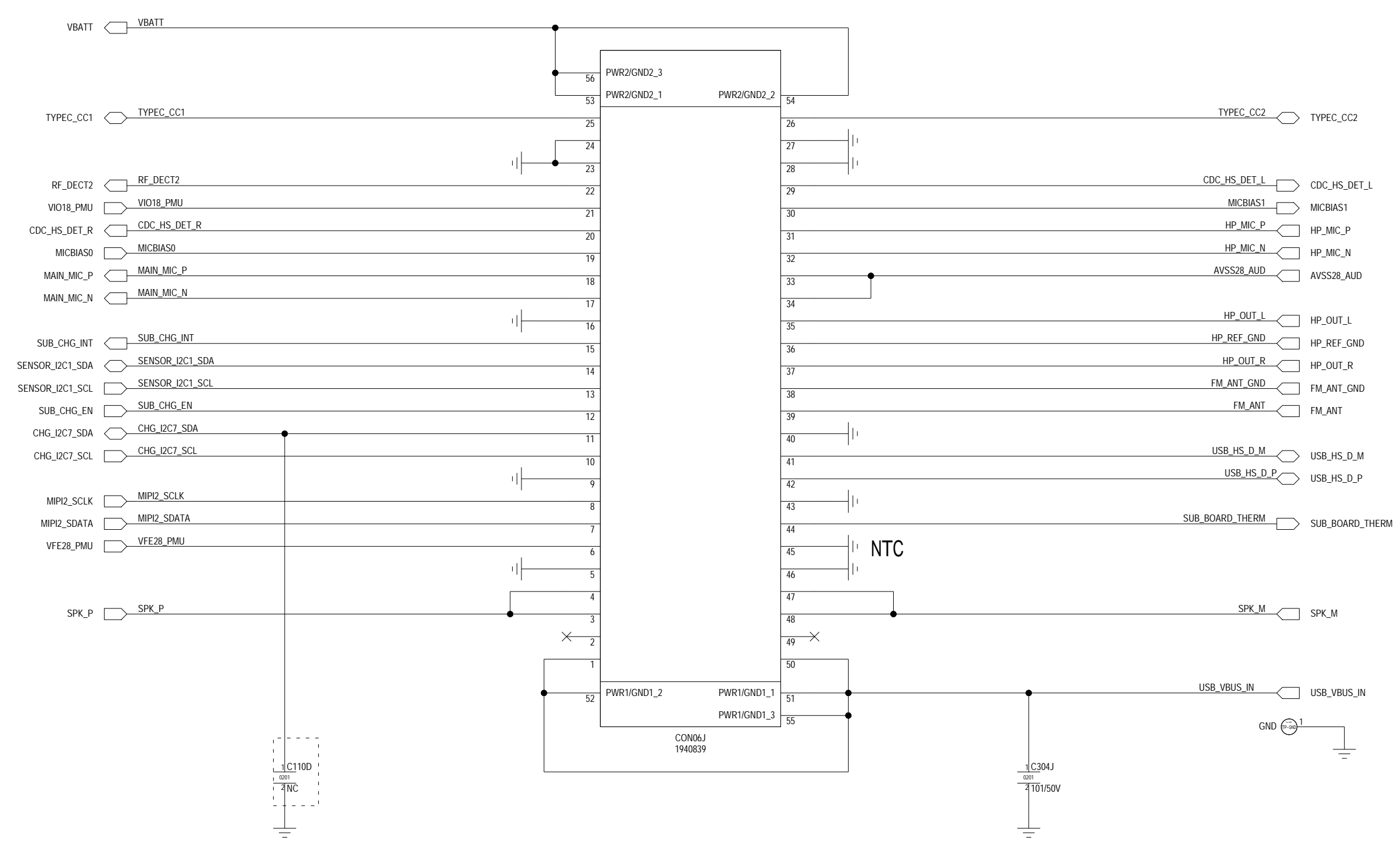

BOM_VAR_Name \${VAR_NAME}	
BOM_VAR_Description \${VAR_DESC}	
Company	<b>vivo</b>
Platform MT6769	Project PD2103
Sheet Name 1_BTUSB_CHARGER	Size A1 Rev -0
Drawn By Ding Song	Page 1 of 2 17/06/2021:11:38

12

11

10

9

8

7

6

5

4

3

2

1

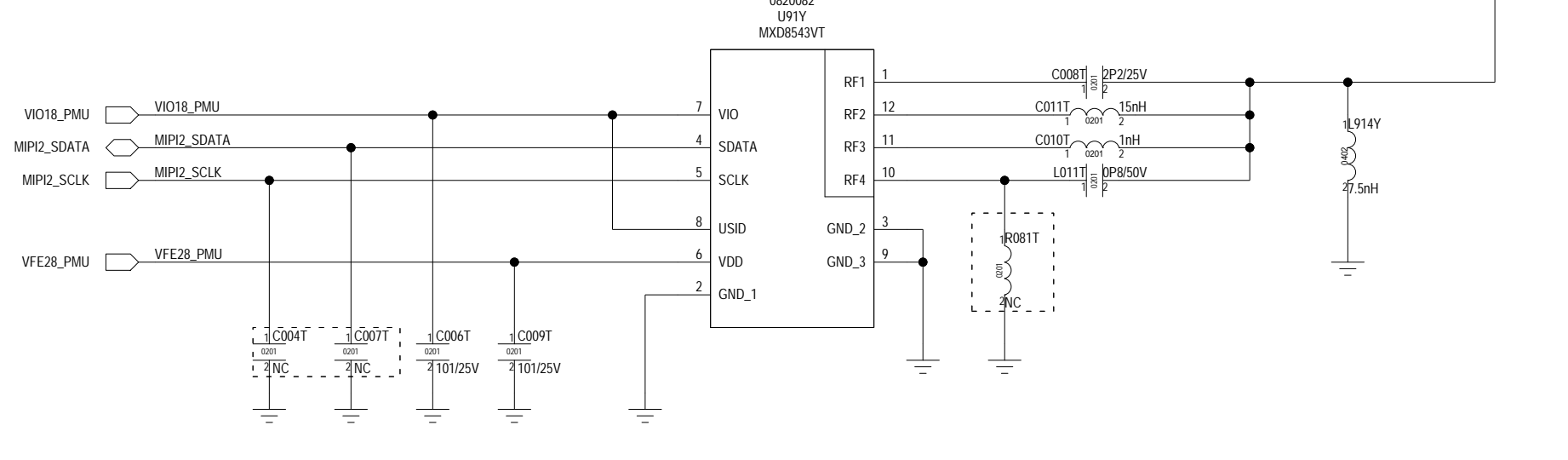
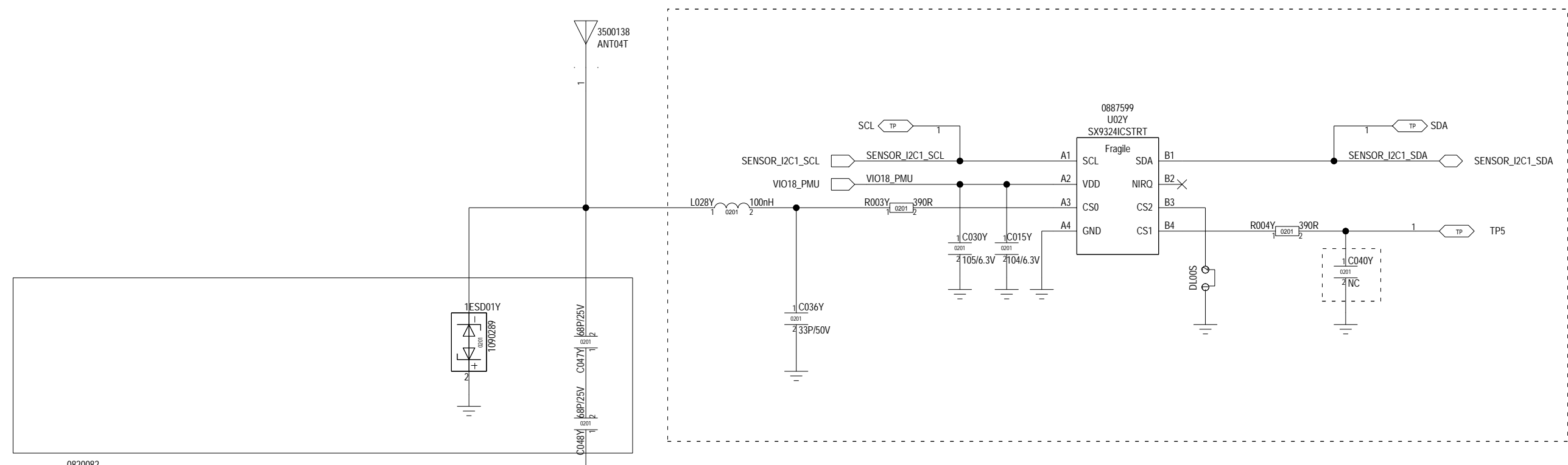
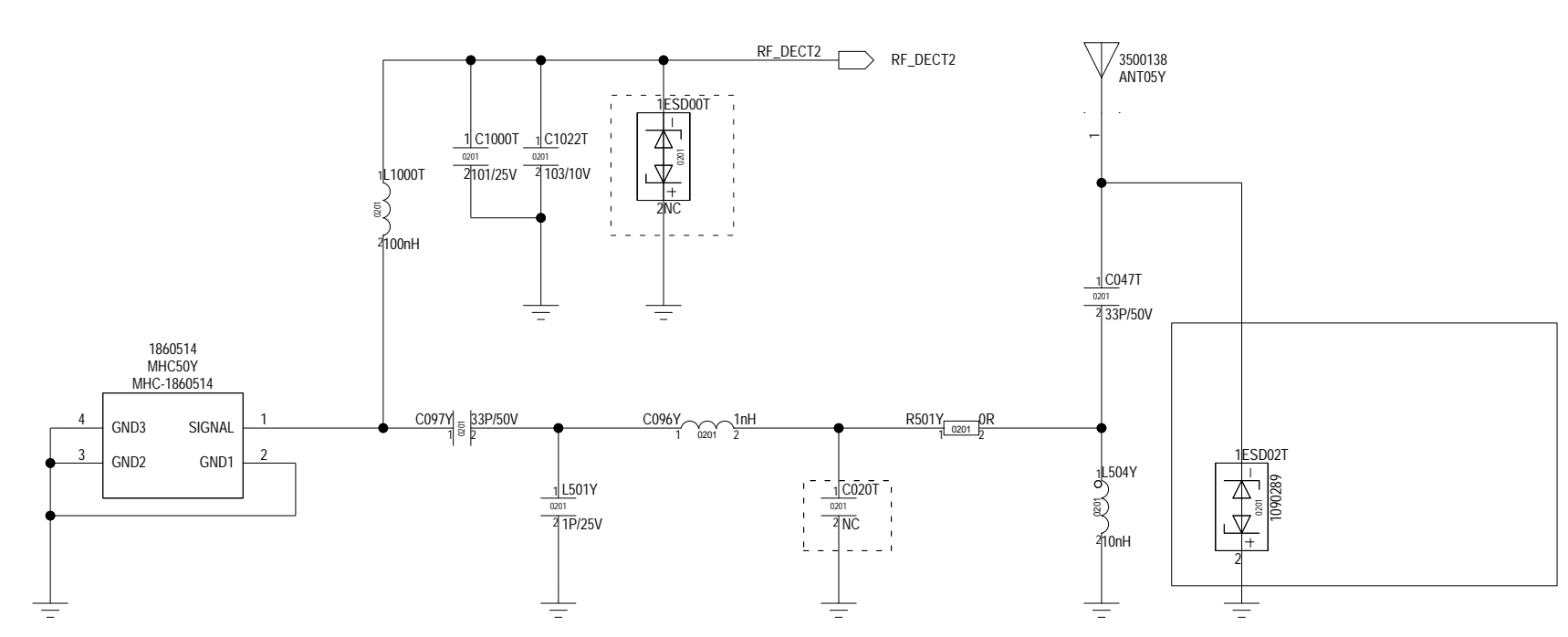
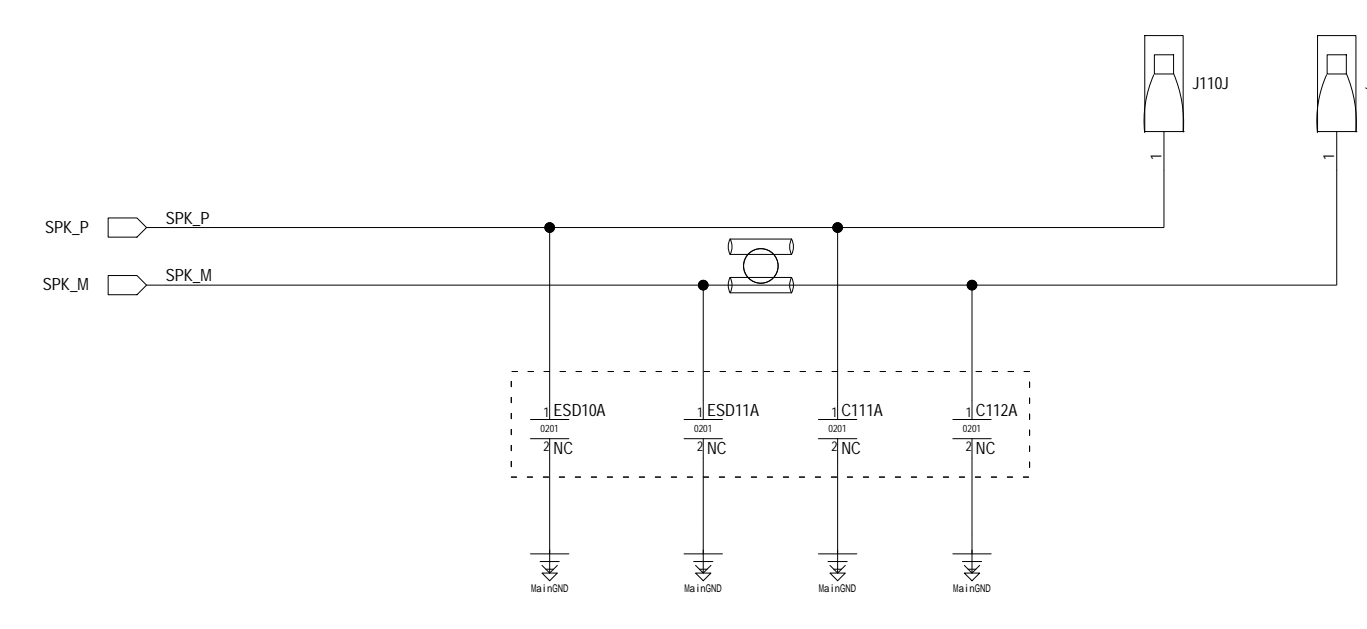
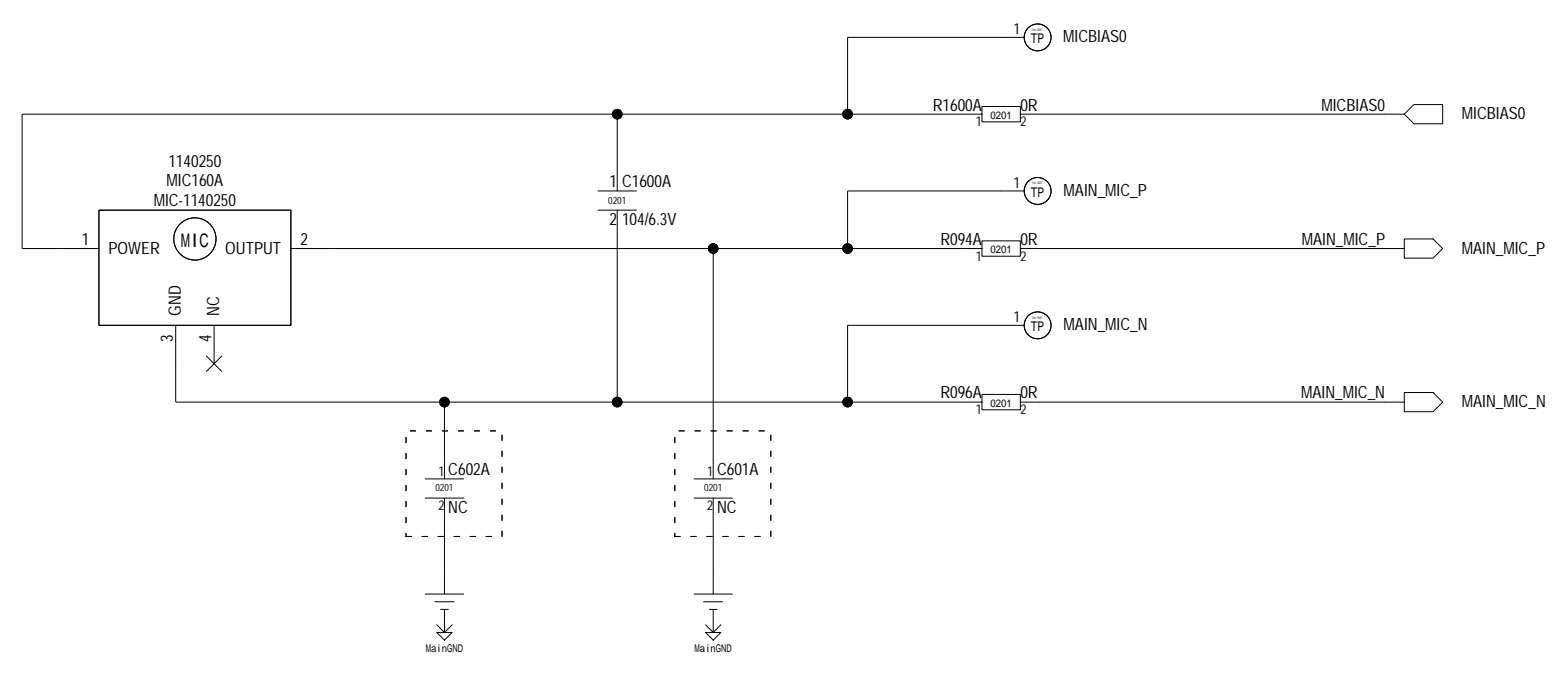
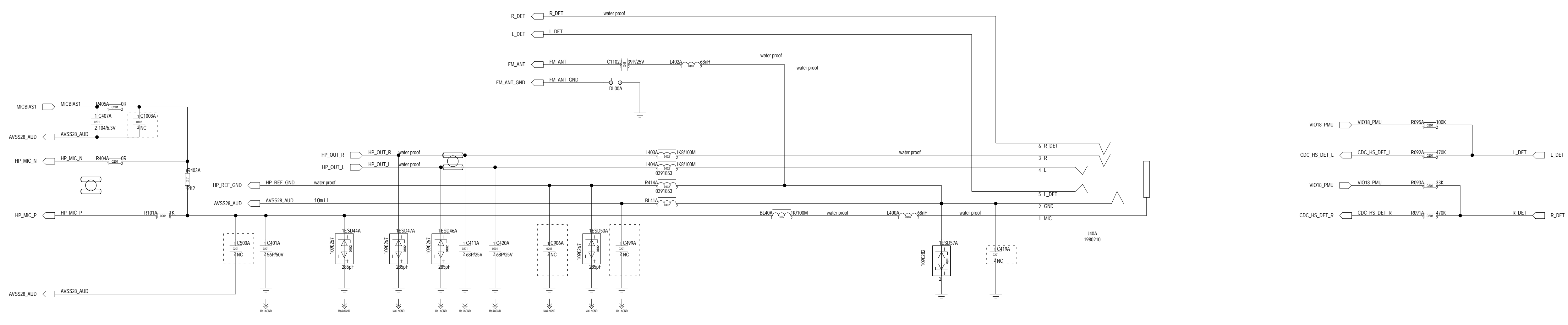

BOM\_VAR\_Name  
\${VAR\_NAME}  
BOM\_VAR\_Description  
\${VAR\_DESC}

Company		<b>vivo</b>	
Platform	MT6769	Project	PD2103
Sheet Name	2_ANT_SPK_MIC_HP		Size A1
Drawn By	Ding Song	Page	2 of 2
			Rev -0
Date		17/06/2021:11:49	