

Multi-channel wireless microphone system

User Instructions

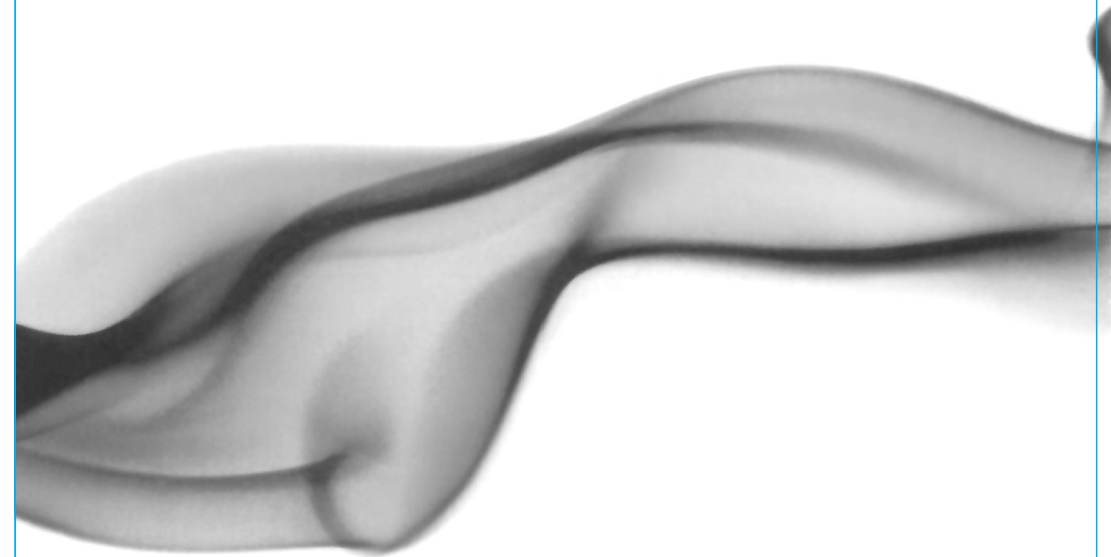

The specification won't do and further for the improvement actual product will not be as pictured

Uses the unit before, please read the instruction manual carefully and keep the instruction manual properly inorder to need in the future

Directory

| | |
|--|----|
| A.Product Introduction | 1 |
| (1) Advantages | 1 |
| (2) Technical Parameters | 2 |
| B.System Components | 3 |
| C.Functional Specifications | 4 |
| (1) Receiver | 4 |
| (2) Handheld/Body Pack Transmitter | 8 |
| (3) Conference Transmitter | 12 |
| D.System Settings | 9 |
| (1) Receiver Operating | 13 |
| (2) Frequency Set | 17 |
| (3) Receiver Display Settings | 19 |
| (4) Transmitter Set | 20 |
| E.Connection | 21 |
| F.Troubleshooting | 22 |

To assure the best performance, please read this manual carefully and keep the manual in a safe place for future reference.

A.Product Introduction

UHF multi channel wireless system is a intelligent multi functional wireless system, adopts UHF multi frequencies design, PLL technology, ultra high frequency wireless transportation, with stable quality, long working distance, clear sound quality, wide and clear LCD display and fashionable outlook design.

This system is suitable for professional stage, multi function hall, conference rooms and teaching rooms.

1、Advantages

UHF Frequency Transmission

It adopts UHF (Ultra High Frequency) band transportation, with frequency range for 610-960MHz. Frequencies can be designed according to the regulations of the country in which they are actually used, so as to be suitable for various countries and regions.

Micro-computer CPU Controlled

The hardware circuit of the whole system is controlled by the CPU of the micro-computer. It can select frequency, display frequency and process frequency data etc. It can realize various functions that are not easy to realize in traditional models.

Wide and Clear LCD Display

With high performance, wide and clear LCD display, all operations can be displayed on the LCD screen to facilitate users to understand the working status of the system and set up the system. Display content includes: radio frequency signal strength, audio signal strength, channel and frequency, ACT working status, etc.

High Precision PLL Technology

Compared with the quartz-controlled system, the PLL technology with high precision phase-locked loop frequency synthesis has higher frequency stability and excellent frequency selection characteristics. It can realize multi-channel and multi-functional professional functions in the system.

Channel Selection

The system is with Channel Selection, and the user can set the working channel according to the actual needs by very simple and convenient operation.

Audio Output

The Audio output is equipped with XLR balanced output and

1/4 inch unbalanced output, which makes it easy for users to connect to different external devices.

Automatic Channel Tracking (ACT)

The system has high-tech automatic channel tracking (ACT) function. After the receiver has set up the receiving channel, the transmitter frequency can be locked automatically and accurately by infrared data transmission, so that the transmitting frequency can be synchronized with the receiver.

Anti-interference Multi Channels Design

The system uses a variety of anti-interference technology. It has 160 non-interference frequencies as the factory default setting. It is reasonable to design and convenient for users to use multi-system at the same time. It is an ideal product for speech and conference rooms.

Battery status indicator/Lower power warning

The battery power of handheld transmitter, bodypack transmitter and conference transmitter can be displayed on their LCD, and the warning is given when the battery power is low, promptly reminding users to change batteries to ensure the normal operation of the system.

Modular Mic Capsule Design

The Mic capsule of the handheld transmitter adopts modular design, which can facilitate users to configure different sound quality Mic capsules to adapt to different occasions.

2. Technical Parameters

System

- Frequency ranges:470.2 MHz- 607.7MHz
- Modulation Mode:FSK
- Available Band Width:500MHz
- Channel number:100(or 200)
- Channel spacing:250KHz
- Frequency stability:± 0. 005%
- Dynamic range:100dB
- Peak deviation:± 45KHz
- Audio response:80Hz- 15KHz(± 3dB)
- Comprehensive SNR:> 105dB
- Comprehensive Distortion:≤0.5%
- Operating Temperature:-10℃ ~ +40℃

Receiver

- Oscillation mode:PLL(Digital frequency synthesizer)
- Stray Reject:≥80dB
- Image Reject:≥80dB
- Sensitivity:5dBuV
- Audio Output Level:XLR Output Jack:250mV /600Ω
1/4" Output Jack:400mV/3kΩ
- Working Voltage:DC 13.5-16V
- Working Current:≤800mA

Handheld Transmitter

- RF Power Output : Max 30 mw
- Oscillation mode:PLL(Digital frequency synthesizer)
- Frequency stability : < 30ppm
- Dynamic range : > 100dB(A)
- Frequency response : 50Hz-15KHz
- Max input pressure : 130dB SPL
- Microphone pickup : Moving coil
- power supply : 2 AA Size Battery

Conference/Body Pack Transmitters

- RF Power Output : Max 30 mw
- Oscillation mode:PLL(Digital frequency synthesizer)
- Frequency stability : < 30ppm
- Dynamic range : > 100dB(A)
- Frequency response : 50Hz-15KHz
- Max input pressure : 130dB SPL
- Microphone pickup : Capacitive
- power supply : 2 AA Size Battery

B. System Components

| All system include: | 2 Channel | 4 Channel | 8 Channel |
|--|------------|------------|-----------|
| Receiver | (1set) | (1set) | (1set) |
| Rack installation parts | (2set) | (2set) | (none) |
| Audio signal cable | (1set) | (1set) | (1set) |
| 1.5V AA Battery | (4) | (8) | (16) |
| Power | (1set) | (1set) | (1set) |
| Antenna | (2) or (4) | (2) or (4) | (4) |
| User Instruction | (1) | (1) | (1) |
| Transmitters System Handheld/Conference/Body Pack | (2set) | (4set) | (8set) |

3. Model and function description and specification (reference) part of the panel

Two Channel:

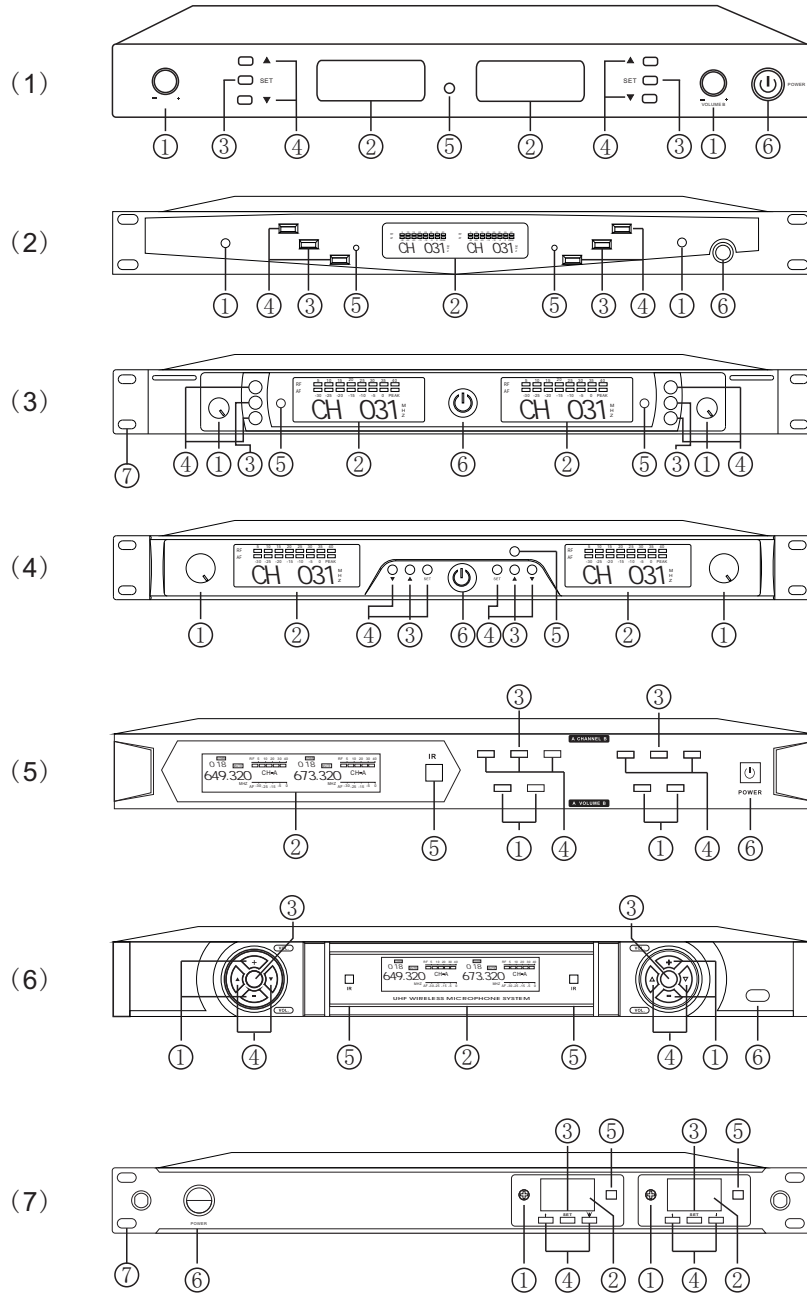

Model and function description and specification (reference) part of the panel

Four Channel:

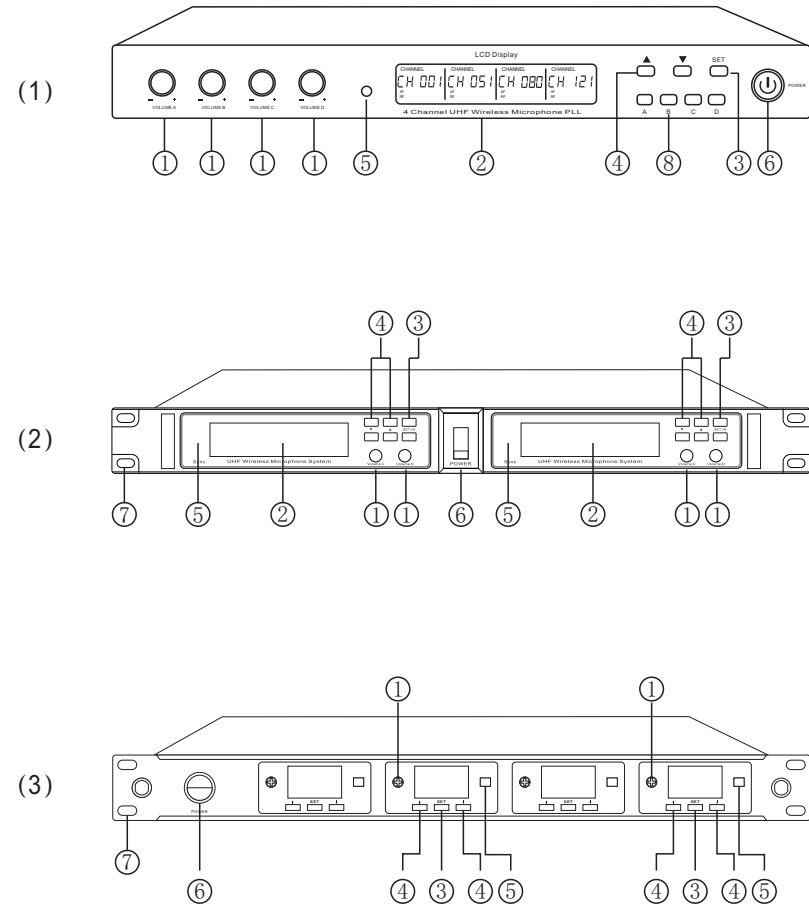

Model and function description and specification (reference) part of the panel

Eight Channel:

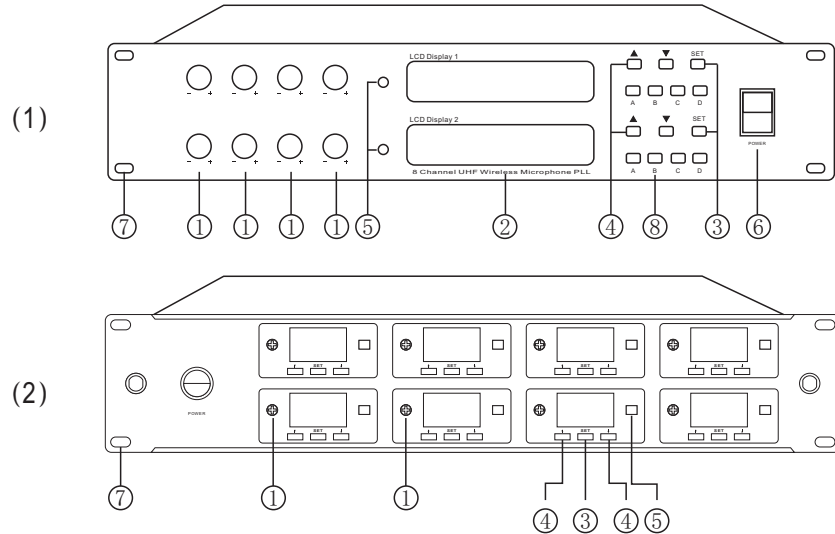

1.Receiver function and instructions

Front Panel

- ① VOLUME control : Adjust the output volume. Clockwise rotation, the volume increase, Counterclockwise, the volume decreases
- ② LCD Display : Display system in the current working state.
- ③ Menu Button : Press SET to confirm the current operation, or press this button to enter the infrared synchronization.
- ④ UP and Down button : Press to adjust the currently selected or next option on the menu.
- ⑤ IR port : Cooperate with synchronous button, the infrared signal transmission to the transmitter, receiver and transmitter frequency synchronization.
- ⑥ POWER Button : Press the power switch, open power supply, LCD is bright; In the light the power switch for 2 seconds, the receiver power shut down.
- ⑦ Rack installation parts : Used to install the receiver fixed 19-inch standard rack.
- ⑧ Channel switch button : Choose the switch to the need to adjust the working channel (mainly used in yituo four yituo eight).

Back Panel function description

Two Channel

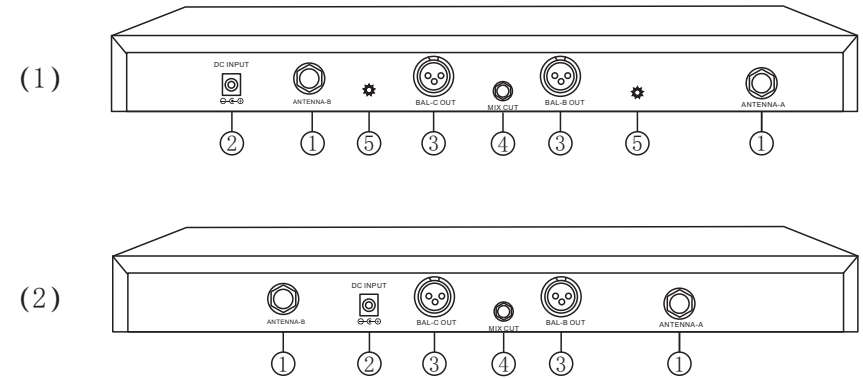

Four Channel

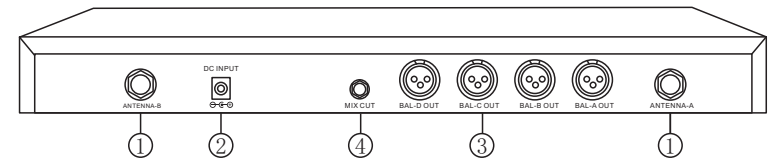

Eight Channel

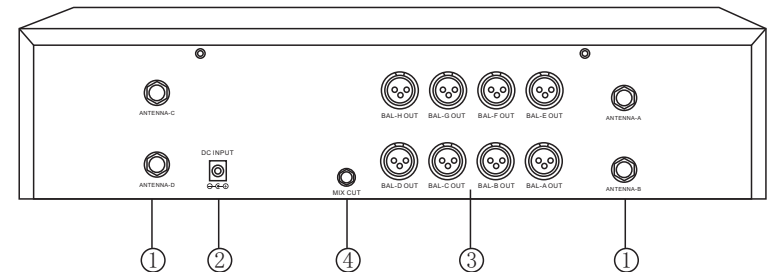

1.Receiver function and instructions

Back Panel

- ①.Antenna connector
- ②.DC Power Input
- ③. Balanced Output:
- ④.Mixing 6.35mm Output
- ⑤.Squelch control

Model:1108

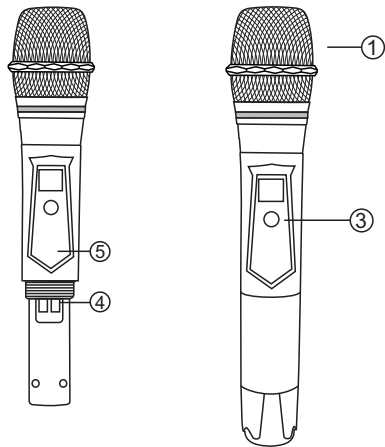

Model:S200

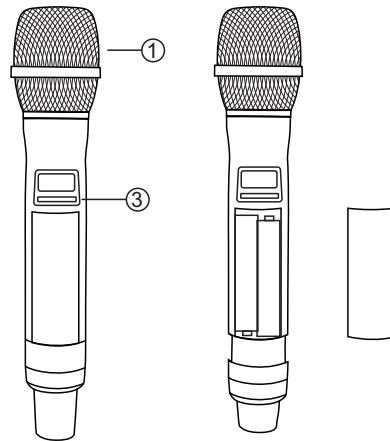

Model:1106

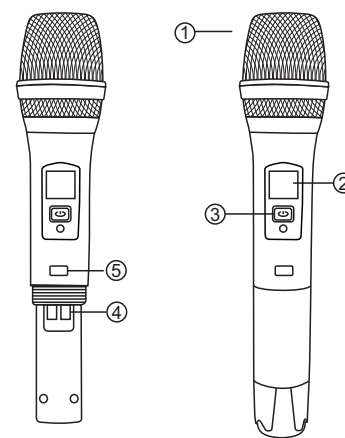

Model:1106S

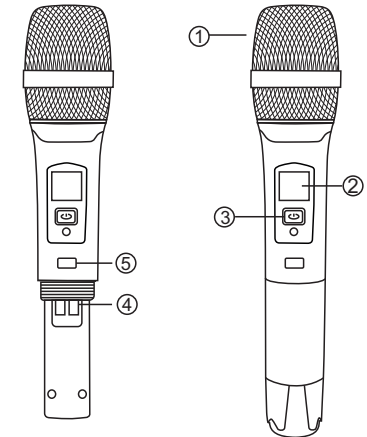

Model:G3

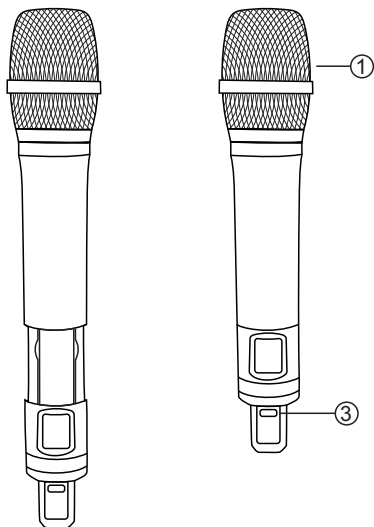

Model:1109

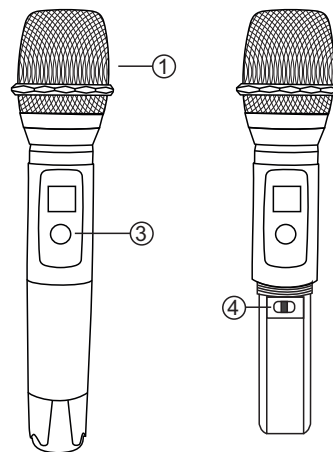

Model:1107

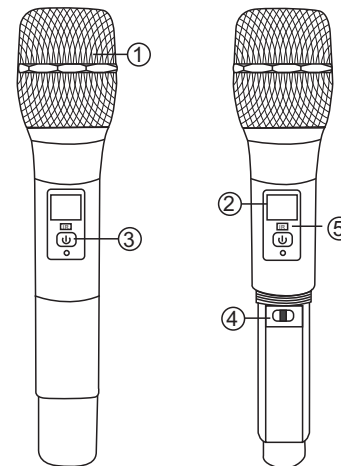

1. Microphone head Section: Including Microphone Cover Net and Microphone Cartiridge Module
2. LCD Display: Display working channels, Battery, infrared frequency of operation, etc.
3. Switch button: Long press 5 seconds on/off the phone
4. High-low power (RF).
5. IR window: used to Synchronous frequency

Body pack Transmitters

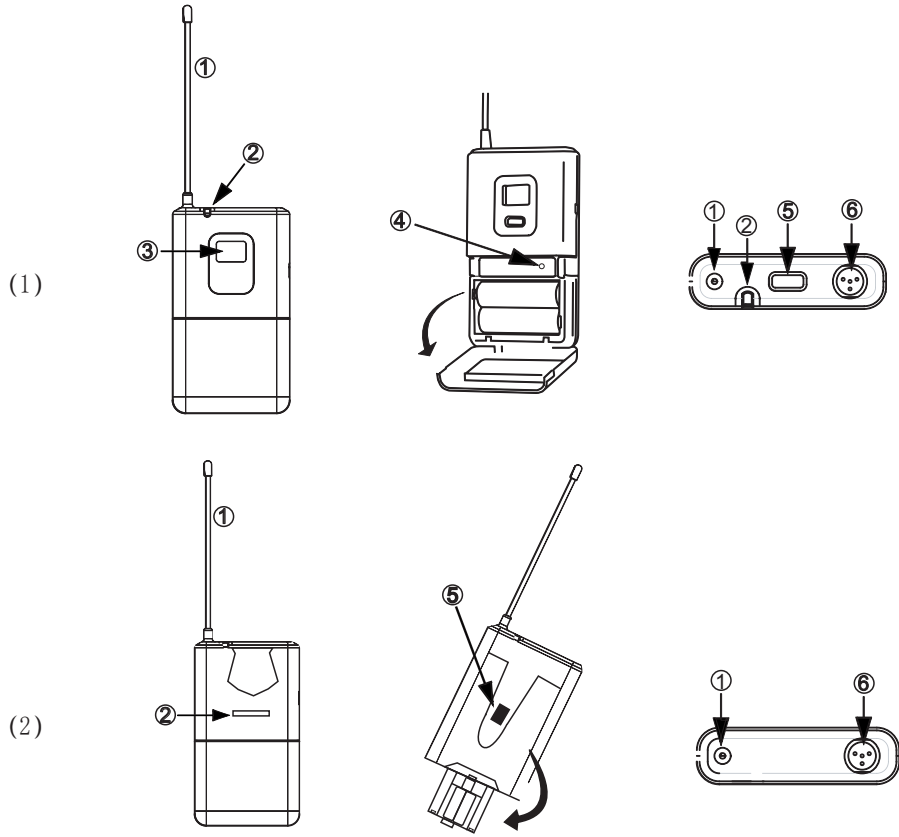

- ① Antenna
- ② Power light
Indicator: the power to open
- ③ LCD Display
- ④ IR Window: Receiving the infrared beam, make
Frequency synchronization. When using, should be at a time
Reveal a transmitter ir port
- ⑤ Power button: ON/Power on; OFF/Power OFF
- ⑥ 3Pin (4Pin) Microphone line input (MIC/LINE)

Wearing of Body Pack transmitter

Attach the pocket of transmitter on the belt with the clip on the back of the transmitter ①, it can also be use on strap/guitar strap as shown by the picture ②, For best performance, the pocket of transmitter should be secured by sliding the clip on to the belt/strap all the way down. ①.

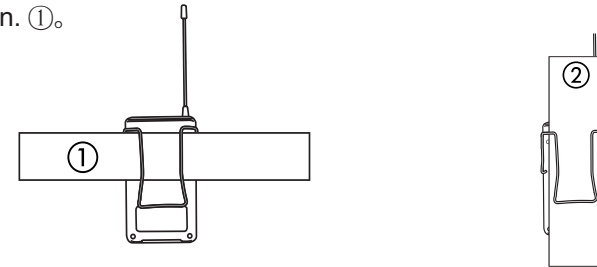

Replace the battery

(A)

The using time of the two batteries is about 8 hours. When the red light of transmitter is flashing, should be replaced Batteries, as shown in the left picture.

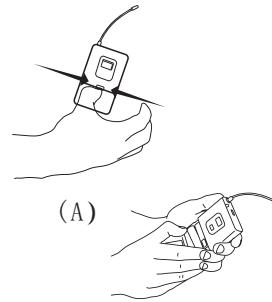

Replace the battery (Used for Body Pack A)

(A) Hold the arrow button to open the cover, unwrapped battery installed.

Replace the battery (Used for Body Pack B)

Figure 2: Press the arrow button, hold the bulge part of the battery holder with your thumb, pull it down and pull out the battery holder.

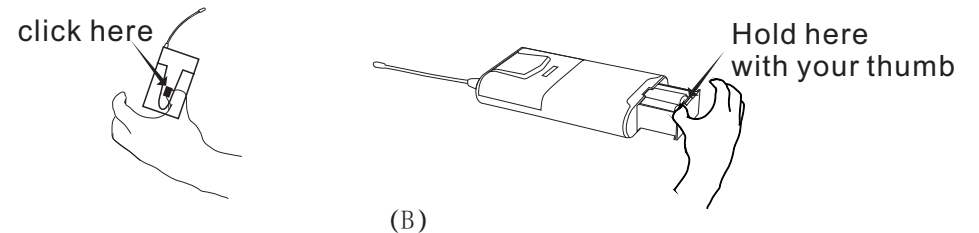

Conference Transmitter (1)

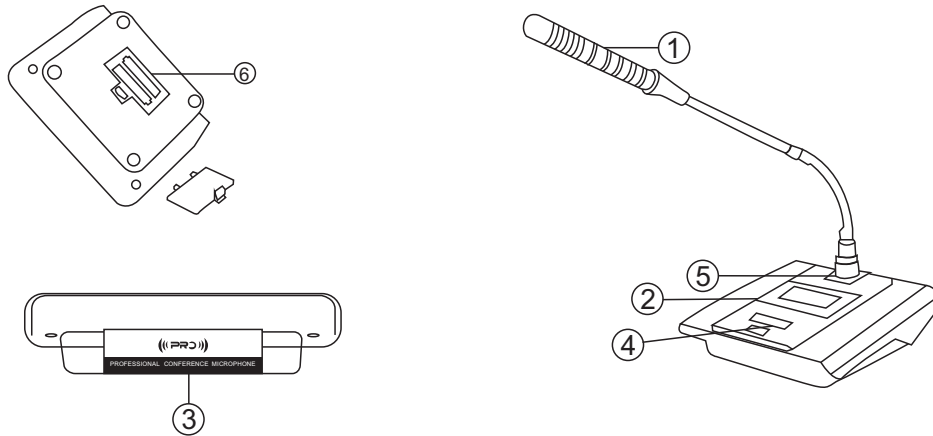

- ① Mic Capsule
- ② LCD Display: Display working channels, Battery, infrared frequency of operation, etc.
- ③ Infrared receiver window: used to change the hair Frequency of shoot machine.
- ④ Power Button
- ⑤ 3Pin (4Pin) Microphone input socket
- ⑥ Battery Holder

Conference Transmitter (2)

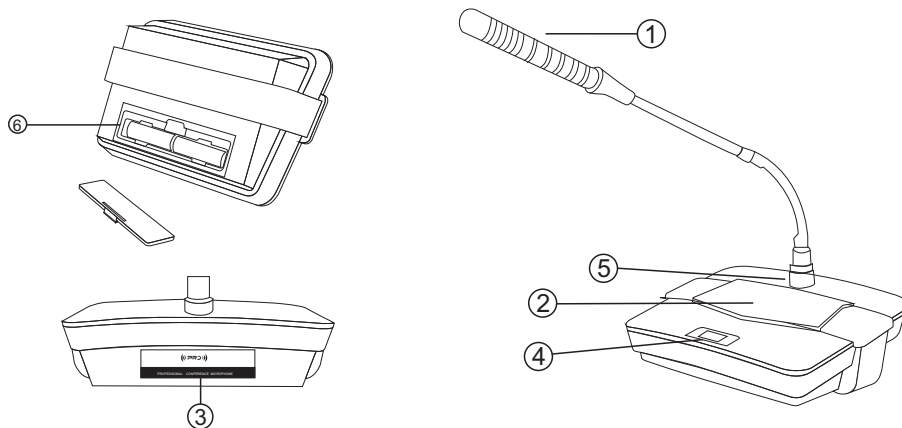

OPERATION OF THE RECEIVER

1. Adjust the volume to the smallest before turned on the transmitter, then turn on the receiver, the LCD lights up and alphanumeric displayed, then LCD will display the channel and frequency of the receiver, press the SET button can change the status.
2. When the transmitter is off, you should observe the RF and AF level, if strong interference appeared, change the channel so as to avoid the interference point.
3. Turn on the transmitter, RF level meter lights up, adjust the volume to the properly, speak, AF level meter of receiver lights up, when there is no sound or the level meter lights don't shine, indicating that the system is abnormal and should be maintained.
4. Press the POWER button for 2 or 3 seconds to turn off the receiver.

OPERATION MENU OF LCD (Used for two channel double screen)

1. Key functions and operations

Press the middle button "SET" can select menu and confirm your Settings. Press "▲" "▼" button to select or adjust the menu, and then "SET" button to confirm your operation. Long press "▲" "▼" key to select frequency and channel quickly.

2. LCD display

A. Infrared frequency

Press the "SET" button when the LCD display "PRG IR", 2-3 seconds later, it will synchronize the frequency to the transmitter.

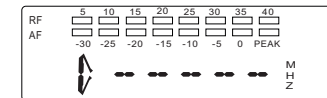
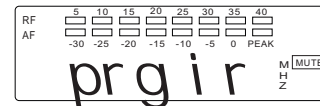

B. Getting into the operating menu



► Press the set button to get into the standard display into the operating menu. into "DISPLAY" menu

- ▶ 2-3seconds later, CHANNEL or FREQU appears.
- ▶ Press the ▲ / ▼button to adjust the setting. By briefly pressing the ▲ / ▼ buttons,the display jumps either forwards or backwards to the next setting continuously. (Illustration:To display which menu depend on the previous SET status.)
- ▶ Press the SET button to store the setting,or the screen flashing after 2-3 seconds indicating that the settings are not available, the transmitter still work at previous setting.

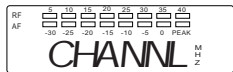

C.Channel/Frequency display

CHANNEL DISPLAY

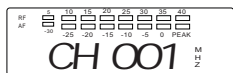
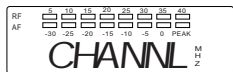

- ▶ Press the SET button and select the CHANNEL mode.This menu shows the current channel.
- ▶ Press the ▲ / ▼ button can change the channel, If you hold down a button, the display cycles continuously. The fast search function allows you to get fast and easily to your desired setting. The new setting flashes on the display until it is stored, or the transmitter will work at the previous channel.

FREQUENT DISPLAY

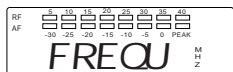

- ▶ Press the SET button and select the FREQU mode. This menu shows the current frequency.

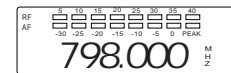

- ▶ Press the ▲ / ▼ button can change the frequency. If you hold down a button, the display cycles continuously. The fast search function allows you to get fast and easily to your desired setting. The new setting flashes on the display until it is stored, or the transmitter will work at the previous frequency.

D.Lock control

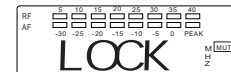

- ▶ Press the SET button until LOCK menu appears.Via the LOCK menu, you can activate or deactivate the lock mode.2-3 seconds later, the screen display the left menu

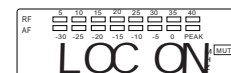

- ▶ (Instructions: To display which menu depend on the previous SET status)

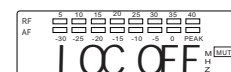

- ▶ The Lock mode determines whether the lock current job status of the receiver (channel,sensitivity,the main display contents,power switch,etc.)



- ▶ The LOCK ON mode prevent to change current work status,including shut down. It enables the receiver or transmitter not to be accidentally programmed or switched during operation.

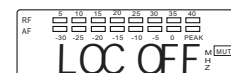

- ▶ To deactivate the lock mode,first press the SET button.Then press the ▲ / ▼ buttons to select LOCK OFF, If you confirm your selection by pressing the SET button, LOCK OFF appears on the display and the buttons can be operated as usual.

OPERATION MENU OF LCD(Used for two channel only one screen)

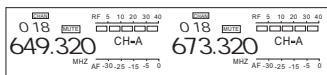

▶ Normal work condition display shows like left picture:

A.Infrared frequency



▶ Press the “SET” button when the LCD display “F---”, 2–3 seconds later, it will synchronize the frequency to the transmitter.

B.SCAN



▶ Long press “SET” button, Frequency digits are beating step by step. The upper left corner square box moves along the horse-racing line and the machine scans the signal of the surrounding environment. See figure in the left:

C.CHANNEL/FREQUENCY

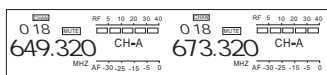

▶ Press the ▲ / ▼ button can change the frequency. If you hold down a button, the display cycles continuously. The fast search function allows you to get fast and easily to your desired setting. The new setting flashes on the display until it is stored, or the transmitter will work at the previous frequency.

D.SYSTEM LOCKED OPERATION

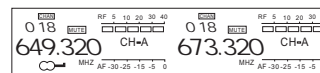

▶ Press “▲” or “▼” button at the same time, the receiver will be locked, and the lower left corner of the display will appear symbols, only allows you to change the frequency of the system. And press “▲” or “▼” button at the same time again to release the lock status, the symbols will disappear. See figure in the left.

2.System settings (suitable for dual channel models)

(1) Single System Settings

Frequency Selection for the receiver

Frequency Selection

Press “▲” or “▼” button to choose frequency, and Press “SET” button to confirm frequency you choose.

Frequency setting for transmitter

See Figure 4 (Dual display) / See Figure 5 (Single display)

Turn on the power of the transmitter.

Put the IR port of the handheld transmitter towards to the IR window of the receiver, or open the battery holder of the transmitter to expose the IR port of the handheld transmitter towards to IR window of the receiver, press SET button to synchronize the frequency. When RF signal appears, the system is working normally.

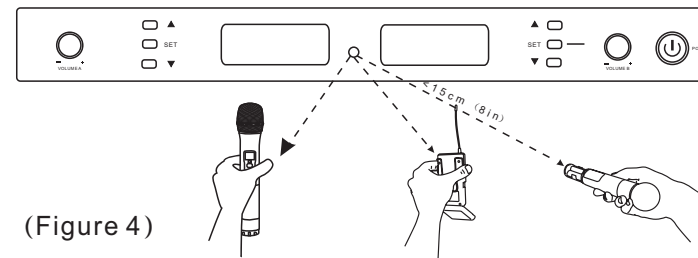

(Figure 4)

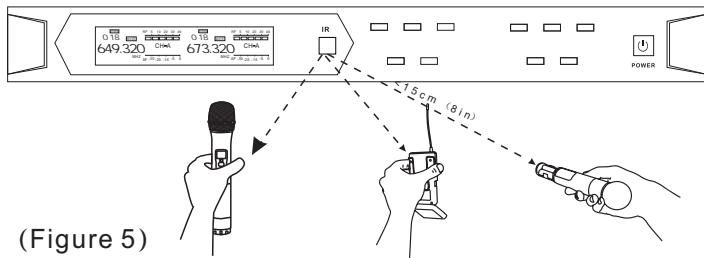

(Figure 5)

**(2) Multi System Settings
(suitable for multi units using at the same time)**

- A. Turn on the power of all receivers, and meanwhile turn off all the transmitters.
- B. Set different frequency for all receivers
- C. Turn on the transmitters of the first receiver
- D. Follow the guidance of single system setting to set the frequency

▶ **Repeat the operations to each system.**

⚠ Pls pay attention; you can only expose IR port of one transmitter when you synchronize the frequency with the system.

2. System Settings (suitable for 4 channels and 8 channels models)

(1) Single System Settings

Frequency Selection for the receiver

Frequency Selection

(single LCD models) , press A, B, C, D button to switch to the relevant channel, and press “▲” or “▼” button to choose the suitable frequency and press “SET” button to confirm the frequency.

(2 and 4 LCD models), Press “▲” or “▼” button according to LCD of the relevant channel to choose suitable frequency, and press “SET” button to confirm the frequency.

IR Synchronization for the transmitters (figure 6)

Turn on the power of the transmitter

Open the batter holder of the transmitter to expose the IR port, and put the IR port towards to IR window of the receiver, press A, B, C, D button to switch to relevant channel, and press “SET” button to synchronize the frequency.

When there is RF signal appear, the system is working normally.

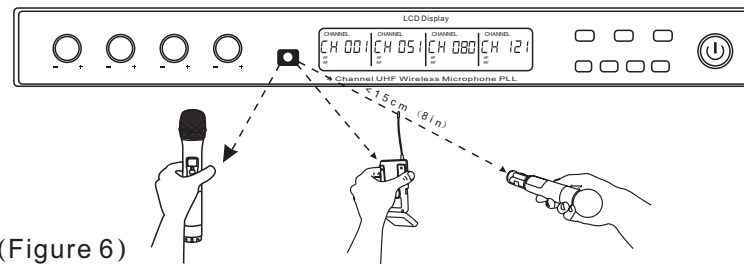

(Figure 6)

(2) Multi System Settings

- A. Turn on the power of all receivers, and meanwhile turn off all the transmitters.
- B. Set different frequency for all receivers
- C. Turn on the transmitters of the first receiver
- D. Follow the guidance of single system setting to set the frequency

▶ **Repeat the operations to each system.**

⚠ Pls pay attention; you can only expose IR port of one transmitter when you synchronize the frequency with the system.

3. Receiver Settings

Any option displayed on the LCD screen will be locked automatically after six automatic flickers.

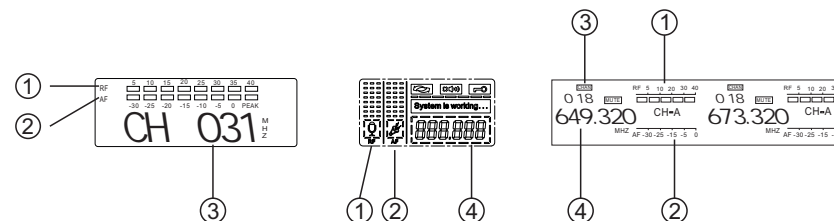

(Figure 7)

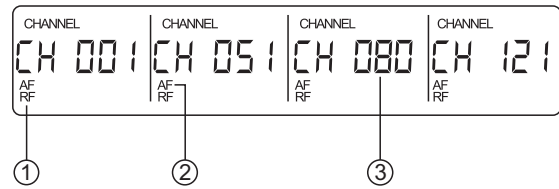

(Figure 8)

**(1) Receiver LCD instruction:
2 channels (figure 7), 4 channels (figure 8)**

- ① RF signal strength display (RF)
- ② AF signal strength display (AF)
- ③ CHANNEL: display the current working channel, when you choose this option, it will flick automatically.
- ④ FREQUENCY: display the current working frequency, when you choose this option, it will flick automatically.

(2) CHANNEL Selection (suitable for 4 and 8 channels)

A. Channel selection: press A or B or C or D button 1 time and press “▲” or “▼” button to choose the certain channel, and press “▲” or “▼” button to choose suitable channel, you can wait for the LCD auto flick for 6 times to synchronize the frequency or you can press SET button to synchronize the frequency.

4. Transmitter Settings

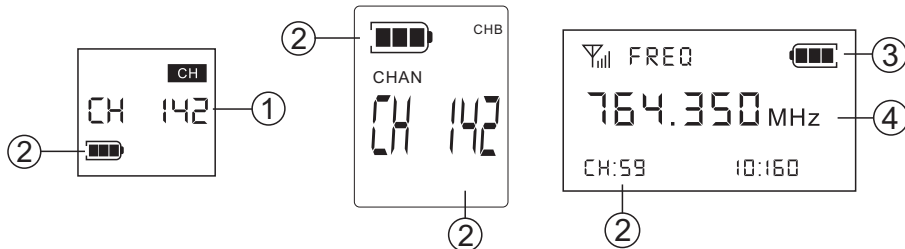

(Figure 9)

(Figure 10)

(Figure 11)

(1) LCD Instruction for Handheld/Bodypack transmitters (Figure 9)

- ① CHANNEL: display current working channel
- ② BATT: Display the Remaining Electricity of Transmitter Battery. When the battery power is low, the sign flashes. The battery should be replaced immediately to ensure the normal operation of the transmitter.

(2) LCD Instruction for Conference Transmitter (Figure 11)

- ① FREQ: display current working frequency
- ② CHANNEL: display current working channel
- ③ BATT: Display the Remaining Electricity of Transmitter Battery. When the battery power is low, the sign flashes. The battery should be replaced immediately to ensure the normal operation of the transmitter.

(3) IR Synchronization for the transmitter

Transmitter can synchronize the working frequency automatically. Please check the guidance above for the IR synchronization for the transmitters from the single system setting.

E. Tips for improving system performance

- *IThe transmitter and antenna should be kept in an accessible linear relative position.
- *IDo not place the receiver close to the metal surface or close to any digital device (such as CD player, computer, etc.).
- *IThe receiver should be protected above 1M from the ground and not close to the wall as far as possible.
- *ITransmitting devices such as cellular phones and bidirectional radios interfere with audio transmission. Transmitters and receivers should be kept away from these devices and other potential sources of interference.

F.Connection

1.Connection instructions for dual channel models (figure 12)

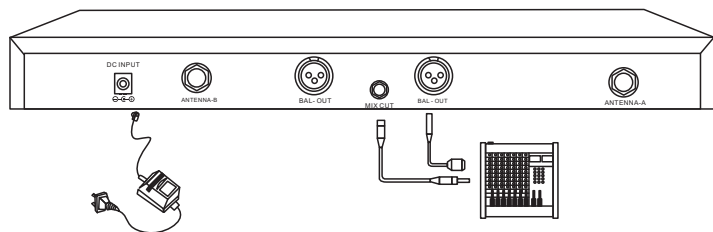

(Figure12)

2.Connection instructions for four channel models (figure 13)

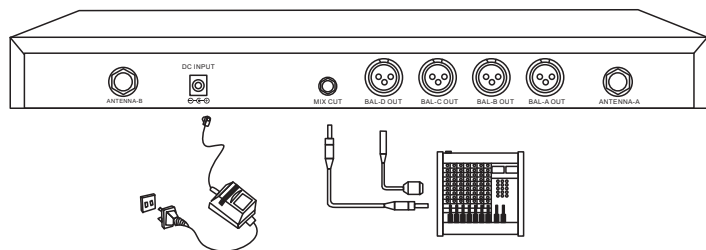

(Figure13)

3.Connection instructions for four channel models (figure 13)

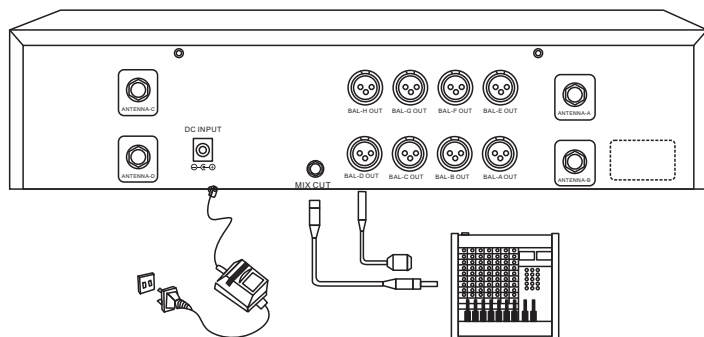

(Figure14)

G.Troubleshooting

| Problem | Possible cause |
|---|---|
| No operation indication | Transmitter's batteries are exhausted or DC in is not connected well. |
| No RF signal | Transmitter and receiver are not at the same channel |
| | Transmitter is out of range |
| RF signal available, no audio signal, "Mute" appears on the display panel | Transmitter is muted("MUTE") |
| | Receiver's squelch threshold is adjusted too high |
| Audio signal has a high level of background noise | Transmitter doesn't transmit a pilot tone |
| | Transmitter sensitivity is adjusted too low |
| Audio signal is distorted | Receiver's AF output level is adjusted too low |
| | Transmitter sensitivity is adjusted too high |
| The use of short distance, Signal instability | Receiver's AF output level is adjusted too high |
| | Transmitter set at a low-power |
| The use of short distance, Signal instability | Squelch is too high |
| | Receiver antenna set improper |
| | Surrounded by strong electromagnetic interference |

FCC warning statement

This device complies with Part 15 of the FCC rules.

Operation is subject to the following two conditions:

- 1) this device may not cause harmful interference, and
- 2) this device must accept any interference received, including interference that may cause undesired operation.

Changes or modifications not expressly approved by the party responsible for compliance could void the user's authority to operate the equipment.

The device has been evaluated to meet general RF exposure requirement. The device can be used in portable exposure condition without restriction.

This device operates on a no-protection, no-interference basis. Should the user seek to obtain protection from other radio services operating in the same TV bands, a radio license is required. For further details, consult Innovation, Science and Economic Development Canada's document Client Procedures Circular CPC-2-1-28, Voluntary Licensing of License-Exempt Low-Power Radio Apparatus in the TV Bands.