

7TOUCH KEYPAD8860
Installation and User Manual

 **Please update eightOS during installation**

We are consistently adding new features and improving the software.
For the best user experience, please update eightOS before completing installation.

Instructions to update can be found on page 13.

1.

Contents

Introduction	4
2. In the Box	5
3. Installation Requirements and Preparation	6
4. Hardware Installation	8
5. Software Setup	12
6. Installing Apps	14
7. Home Screen	16
8. Quick Actions Menu	18
9. Restarting 7TOUCH KEYPAD	19
10. Settings Screen	20
11. Primary Apps	22
12. App Library Lock	24
13. Troubleshooting	26
14. Warranty	26
15. Product Feedback	26
16. Support	27

1. Introduction

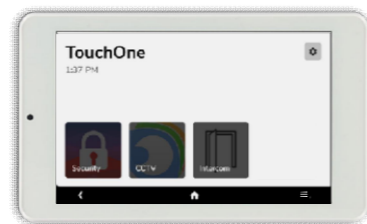

7TOUCH KEYPAD8860

Welcome to the next generation of centralised control for the smart technology around you!

7 TOUCH KEYPAD8860 features a best in class 64-bit CPU for blazing fast performance, paired with our best in class smooth capacitive touch panel, and gorgeous 7" HD IPS display. 7 TOUCH KEYPAD8860 is available in 3 colour options to perfectly blend into your environment.

2. In the Box

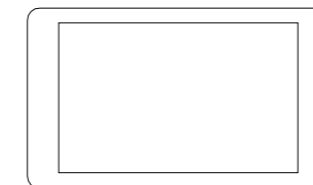

7TOUCH KEYPAD8860

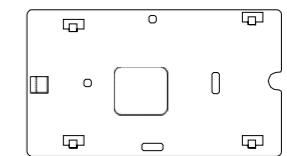

Wall Mount

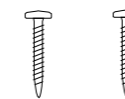

Wall Screws
(two pieces)

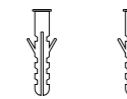

Wall Anchors
(two pieces)



Wire Harness

3. Installation Requirements and Preparation

Power Supply

7TOUCH KEYPAD8860 requires a 12V–14V 15W power supply (measured at the end of line) for smooth operation. Certifiedcompatible power supplies include:

- Mean Well GE1 8I12–P1J Plug Pack (used in the 8PS–PP1 8xx–1x power supply kit)
- Mean Well APV-16-12 / APV-16E-12 Power Supply (used in the 8PS-IW15-1x power supply kit)
- 7TOUCH KEYPADPoE Adaptor (Used in 8PS-POE25-1x power supply kit)For an updated list, please visit mytouchone.com/g3-power

Wire Harness

7TOUCH KEYPAD8860 includes a 4-wire wire harness for connection to power and data (either via a suitable connector or soldering). Power requirements are listed in the Power Supply section above. The 2–wire data connection is for Certifiedcompatible control systems.

7TOUCH KEYPADCertified compatible power supplies (8PS–PP1 8xx–1x or 8PS–POE25) include a different wire harness for a tool–less plug-and-play connection.

Orientation

7TOUCH KEYPAD can be mounted in either Landscape or Portrait orientation to provide the best user experience for the applications you will be using.

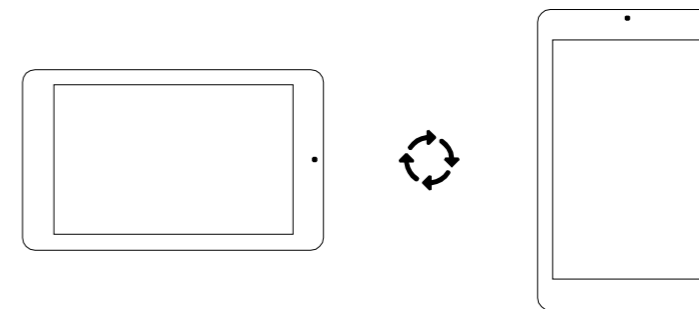

⚠ Important Notice

Some applications will only support one orientation so it's important to check the orientation compatibility of the apps you want to use before screwing 7TOUCH KEYPAD to the wall.

4. Hardware Installation

Step 1 - Install Power Supply

The selected power supply should be installed as per the included instructions. For safety, make sure the power supply is turned off during the installation process. If you are using the 7TOUCH KEYPAD Barrel Jack Adaptor, it's recommended to cable tie the power supply wire and the barrel jack wire together to ensure they don't become disconnected during installation.

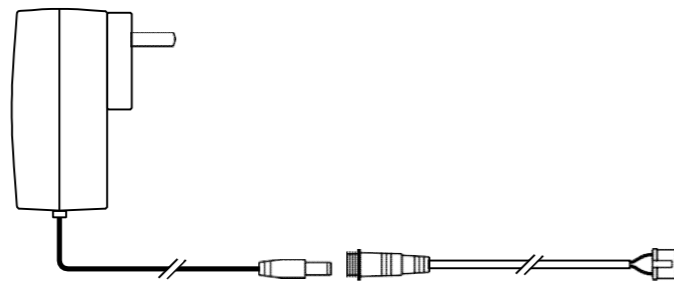

Example of power supply installation. Please refer to the installation manual of the power supply.

Step 2 - Mark and Drill Holes

Hold the included Wall Mount onto the wall in either Portrait or Landscape, using a spirit level to ensure the mount is level. Mark two screw holes and the wire cutout using a pencil.

For mounting to plasterboard: Drill two 2.5mm (7/64 inch) pilot holes.

For mounting to masonry: Drill two 6mm (1/4 inch) holes for the included wall anchors.

If the wire is being fed through the wall, drill an appropriately sized hole (at least 20mm or 3/4 inch) in the wire cutout for the wire to come through.

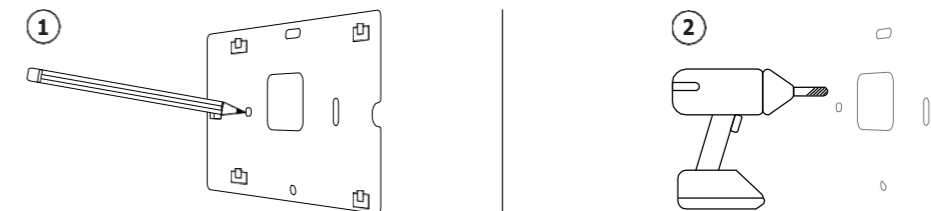

⚠ Important Notice

If mounting to a standard flush box, use the appropriate screw holes for the flush box. 6-32 UNC flush box screws can be used with the Wall Mount instead of the included screws.

Step 3 - Screw Mount to Wall

Using the included screws, screw the Wall Mount to the wall. Double check for level when tightening the screws.

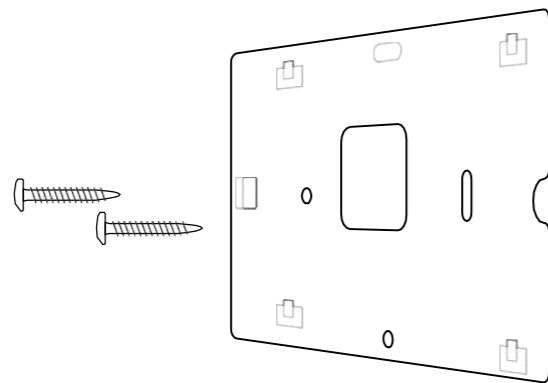

10

Step 4 - Wire and Connect to Power

Bring the power supply wire through the wire cutout and connect to the back of 7TOUCH KEYPAD.

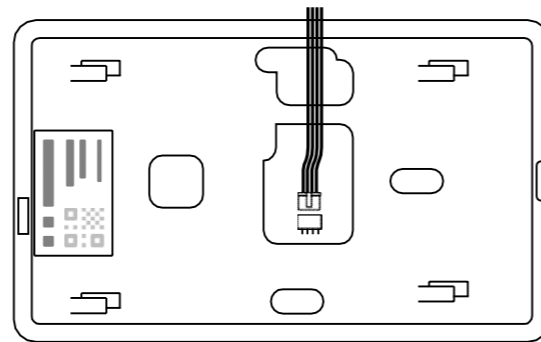

Step 5 - Mount 7TOUCH KEYPAD

Feed the wire back into the wall and mount 7TOUCH KEYPAD onto the Wall Mount. Slide 7TOUCH KEYPAD in the opposite direction of the camera until you feel a click.

Once you apply power to the power supply, 7TOUCH KEYPAD will boot automatically. In a successful installation, you'll see the 7TOUCH KEYPAD logo within 3 seconds of applying power.

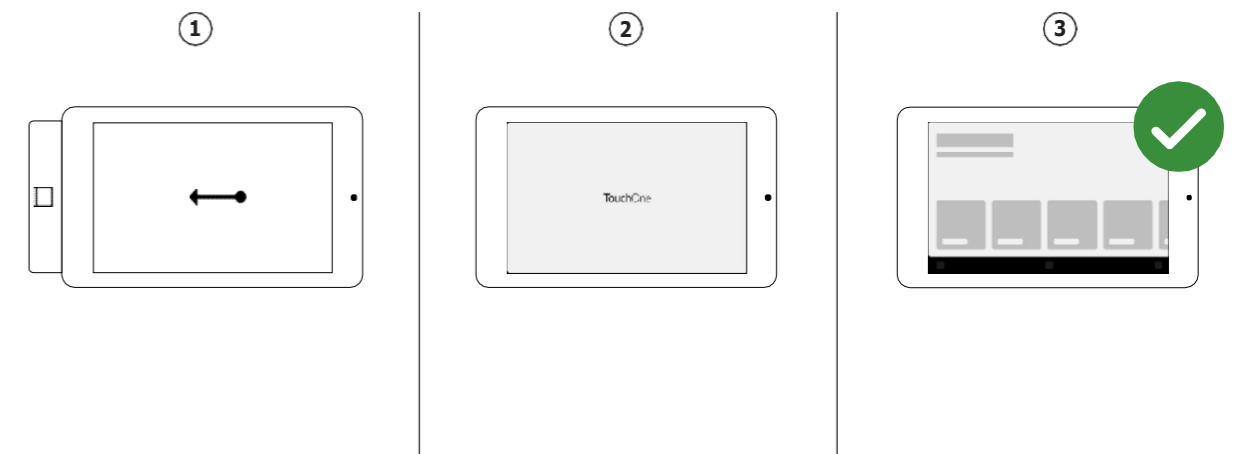

11

5. Software Setup

Step 1 - Connect to Wi-Fi

1 From the 7TOUCH KEYPAD Home screen, tap the Settings button.



2 Tap Wi-Fi.

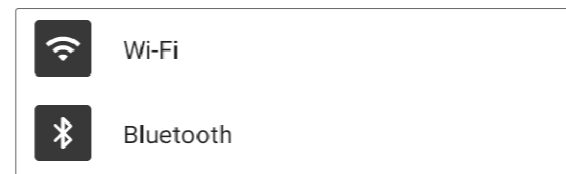

3 Tap the network you want to connect to.

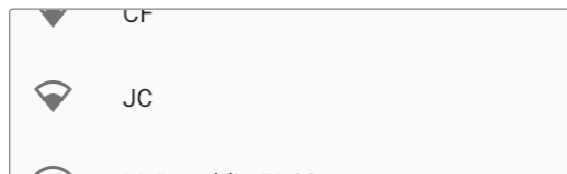

4 Enter the network password and tap Connect.

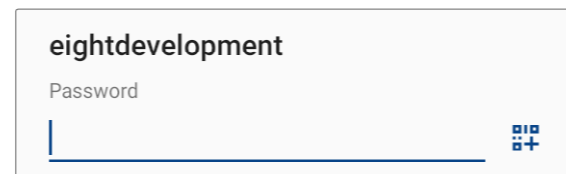

12

Step 2 - Update eightOS

1 From the 7TOUCH KEYPAD Home screen, tap the Settings button.



2 Tap Apps.

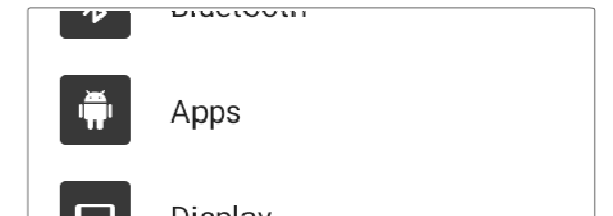

3 If there is an update available, tap the "Update" button next to "eightOS".

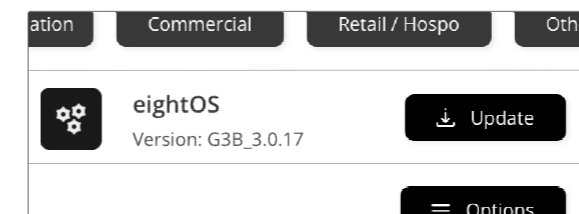

4 Follow the on-screen instructions to complete the update.

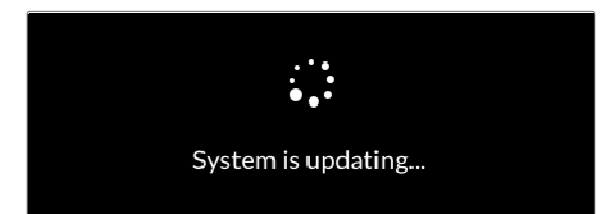

13

6. Installing Apps

7TOUCH KEYPAD8860 runs most Android 10 compatible applications. In order to ensure compatibility of the application, apps are certified by eight. You can install new apps with the following methods:

Pre-Loaded Apps - A number of applications are pre-loaded on 7TOUCH KEYPAD8860 and can be installed in the Apps section of the settings menu. The list of pre-loaded apps differs depending on your product distributor.

SD Card - New apps can be installed via SD Card. You can download an app file from our Knowledge Base at mytouchone.com/g3-apps.

The ability to download new apps on the device from the internet will be released on a later version of eightOS 3.

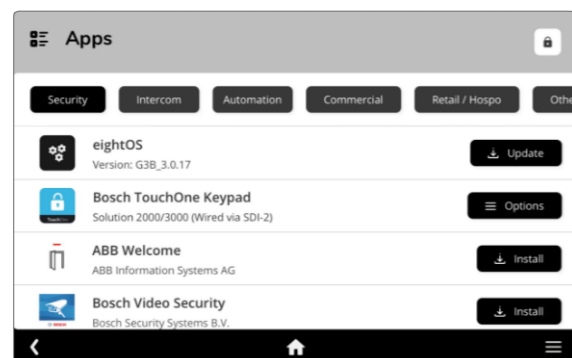

Installing and Uninstalling Apps

1 From the 7TOUCH KEYPAD Home screen, tap the Settings button.

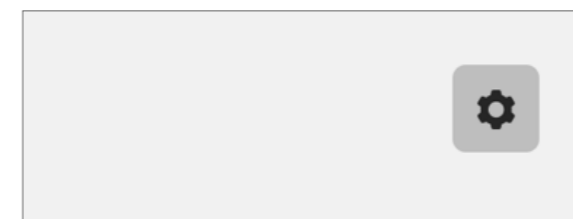

2 Tap Apps.

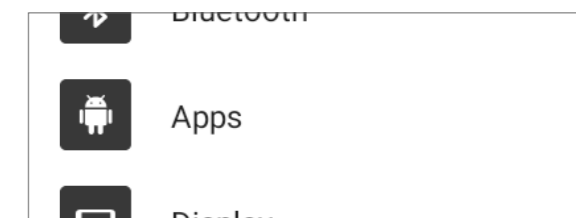

3 Next to the app you want to install, tap the Install button.

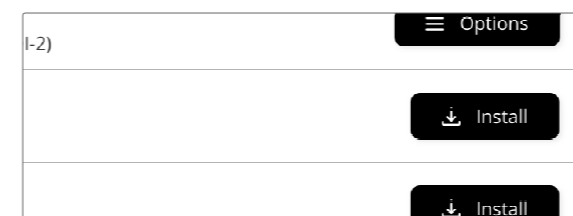

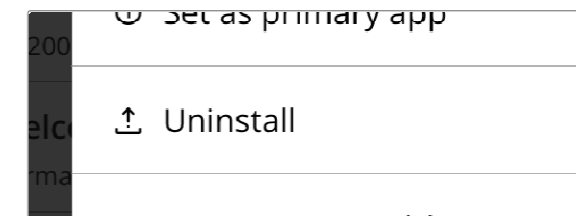

4 To uninstall an app, tap Options next to the app and then the Uninstall button.



7. Home Screen

The Home screen is the first screen you will see when 7TOUCH KEYPAD turns on. Home screen functions are:

Device Name	Customise your device name in the Settings Menu. Select About tablet and then tap Device name.
Current Time	Shows the current time in 12-hour format. Time can be adjusted in the Settings Menu, then tap Date & time.
Settings Button	Opens the Settings Menu.
App Drawer	Shows the currently installed third party applications.
Bottom Bar (If an app hides the Bottom Bar, swipe up from the bottom to show it)	<p> Back Button Goes back one screen on the app that is open.</p> <p> Home Button Takes you back to the Home screen from any app.</p> <p> Quick Actions Menu Button Opens the Quick Actions Menu to quickly adjust volume and brightness and perform a limited number of quick actions from any app.</p>

Device Name

Current Time

Settings Button

App Drawer

Bottom Bar

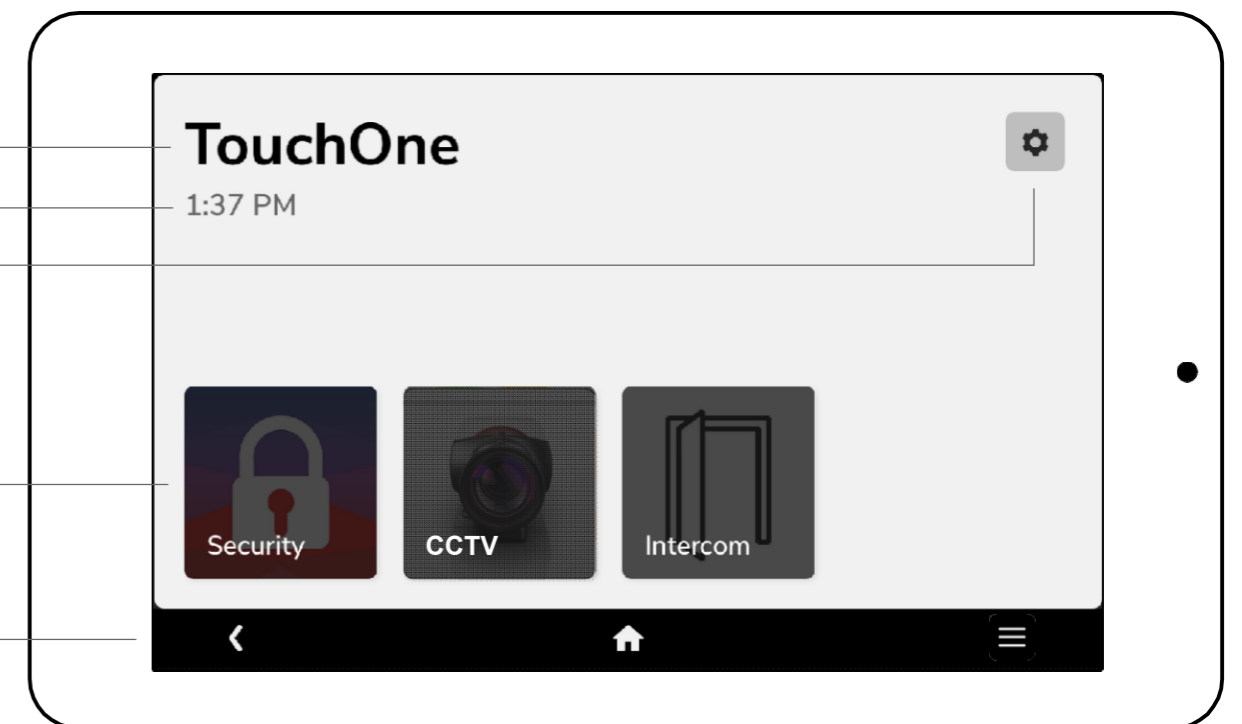

8. Quick Actions Menu

The Quick Actions Menu lets you quickly adjust critical settings for 7TOUCH KEYPAD from any application. It's launched by touching the Quick Actions Menu button in the bottom right hand corner.

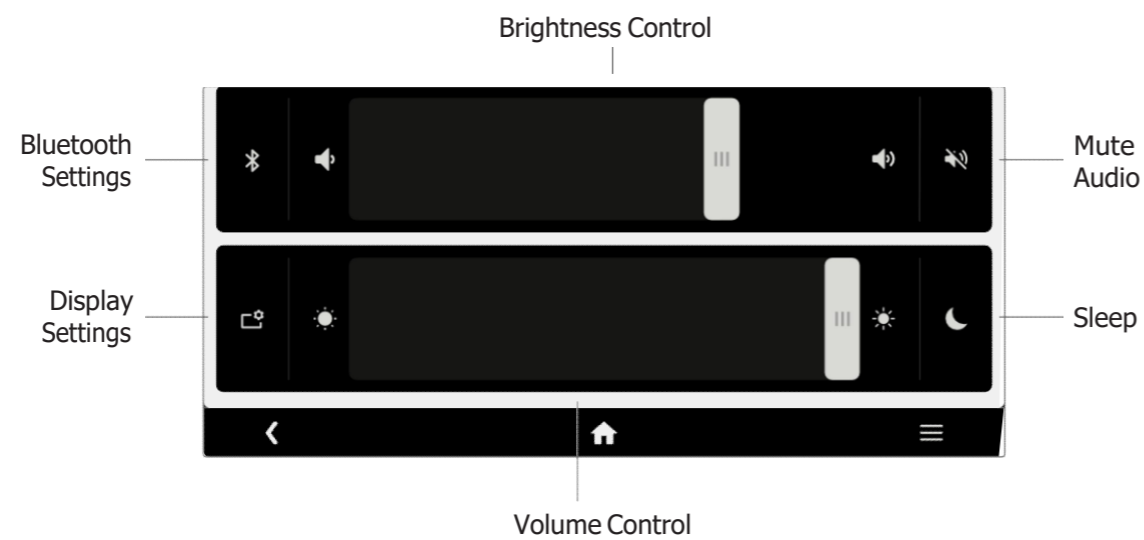

9. Restarting 7TOUCH KEYPAD

Should you need to restart 7TOUCH KEYPAD, you can do this from the Quick Actions Menu.

- 1 From any screen, touch the Quick Actions Menu button to launch the Quick Actions Menu.



- 2 Touch and hold the sleep button for 3 seconds.



- 3 Touch Restart.

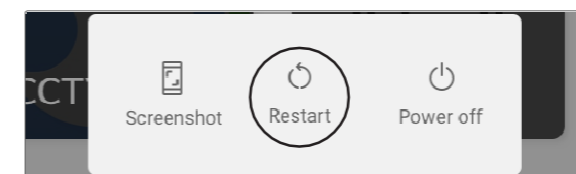

- 4 7TOUCH KEYPAD will restart.

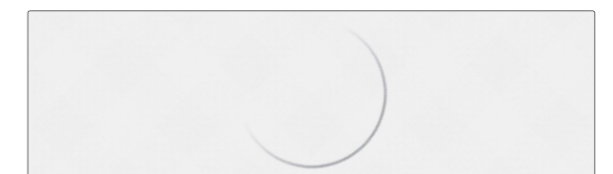

10. Settings Screen

The Settings screen allows you to change various configurable options on 7TOUCH KEYPAD. The Settings menu has the following functions:

Wi-Fi	Connect & disconnect to Wi-Fi networks. Configure networks with a static IP or alternative DNS settings. View IP Address information.
Bluetooth	Pair and connect Bluetooth devices. Commonly used to connect 7TOUCH KEYPAD to a Bluetoothspeaker system or audio adaptor for music control.
Apps	View the list of third-party applications and install / uninstall these apps. More apps will automatically appear in this list when an SD Card is inserted, with apps provided by the manufacturer in SFZ/SDZ format.
Display	Configure display brightness, sleep and device orientation settings.
Sound	Adjust volume and other sounds settings.
Date & time	Set the date and time, automatic network provided time, time zone and format.
About 7TOUCH KEYPAD	View the device serial number and various version information. Open source license information can also be found here.

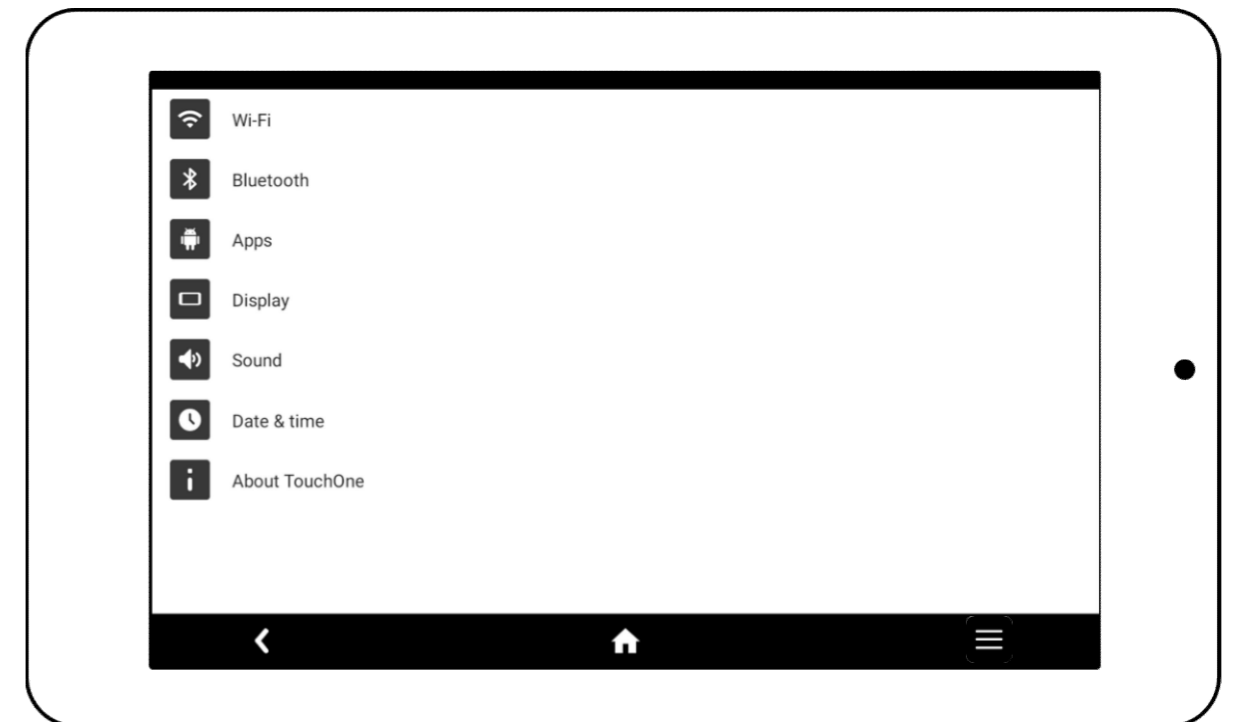

11. Primary Apps

A Primary App is an app that automatically starts when 7TOUCH KEYPAD is started and can also be configured to automatically re-open after a configurable amount of time. An app that is configured to be the primary app is identified by the "Primary App" icon in the App Library list.

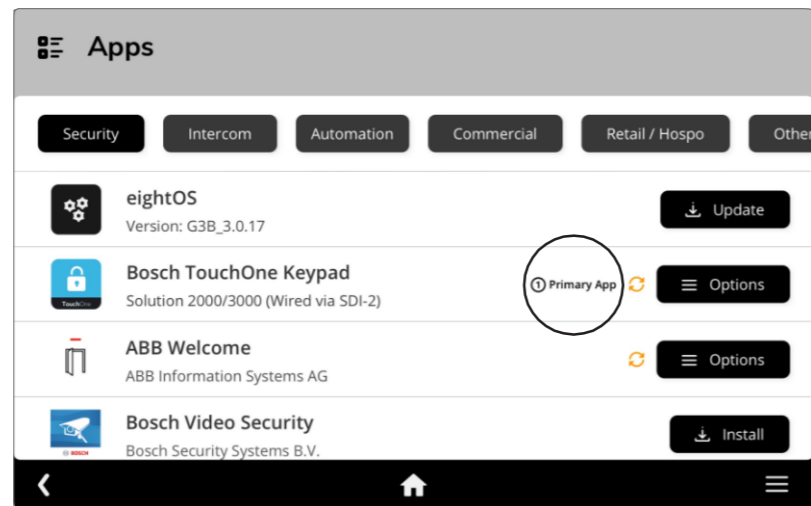

Configuring a Primary App

1 From the 7TOUCH KEYPAD Home screen, tap the Settings button.

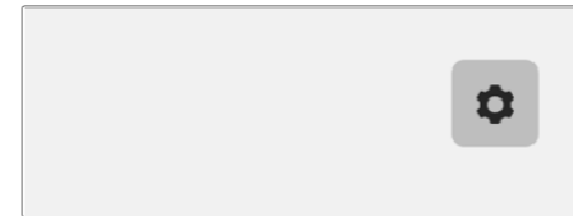

2 Tap Apps.

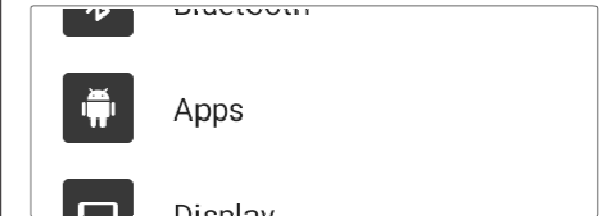

3 Next to the app you want to configure to be the Primary App, tap Options.

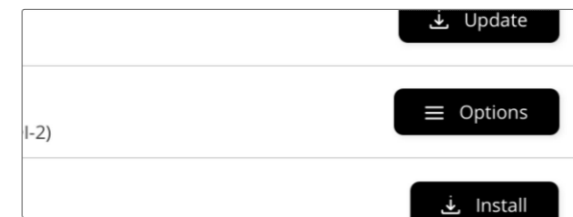

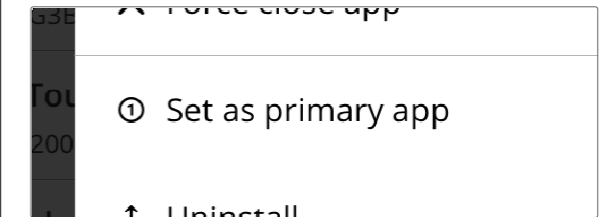

4 Tap Set as Primary App and follow the remaining on-screen instructions.

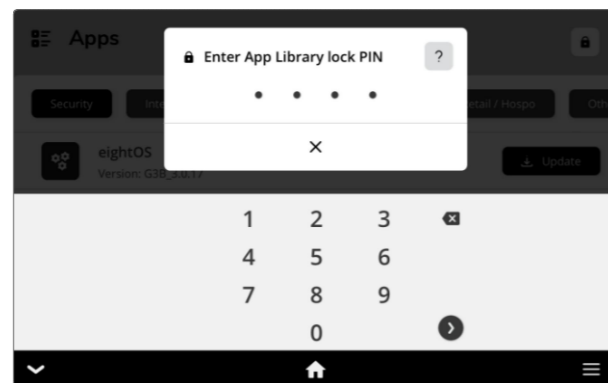

12. App Library Lock

To ensure unauthorised users cannot access the app library, you can enable the App Library Lock and require a PIN Code before a user can modify the installed apps on the system.



⚠ Important Notice - Forgotten PIN
 If you forget your App Library Lock PIN, you'll need to have this manually reset through your 7TOUCH KEYPAD distributor. Tap the  icon on the PIN entry screen and follow the on-screen instructions to have your PIN reset.

Configuring the App Library Lock

1 From the 7TOUCH KEYPAD Home screen, tap the Settings button.

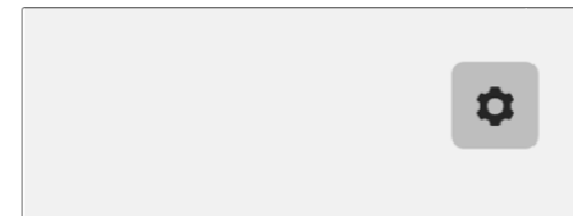

2 Tap Apps.

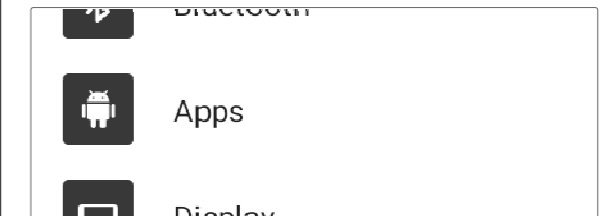

3 Tap the App Library Lock button.

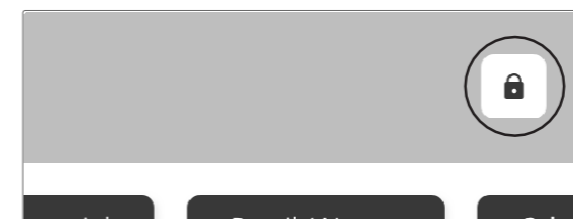

4 Tap Setup App Library lock PIN

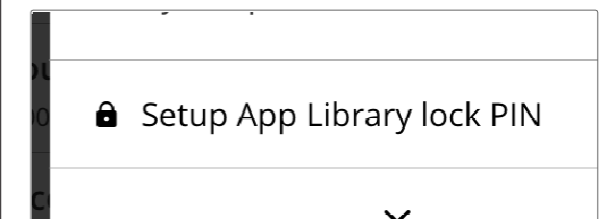

13. Troubleshooting

Our 7TOUCH KEYPAD Online Knowledge Base contains an up-to-date list of common problems that may cause the installation of 7TOUCH KEYPAD8860 to not go as planned and ways to resolve these. You can access this Knowledge Base at:

 mytouchone.com/g3-faq

 Scan the QR code on your phone to be taken to the support knowledge base.



14. Warranty

7TOUCH KEYPAD8860 and all accessories included in the product box are backed by a 3 year warranty from the date of purchase. Please contact us at support@mytouchone.com or refer to your point of purchase.

15. Product Feedback

We always appreciate product feedback. If you have some ideas on how we can make this product better for you, please don't hesitate to email feedback@mytouchone.com or provide the feedback to your point of purchase.

16. Support

If you are experiencing any issues with 7TOUCH KEYPAD8860, we recommend to contact the technical support team at your point of purchase, or you can visit our support portal using this link:

 support.mytouchone.com

 Scan the QR code on your phone to be taken to the support portal.



eight

Connecting humans to technology through beautifully simple user interfaces

FCC Caution:

This device complies with part 15 of the FCC Rules. Operation is subject to the following two conditions:(1) this device may not cause harmful interference, and (2) this device must accept any interference received, including interference that may cause undesired operation.

Any changes or modifications not expressly approved by the party responsible for compliance could void the user's authority to operate the equipment.

NOTE: This equipment has been tested and found to comply with the limits for a Class B digital device, pursuant to Part 15 of the FCC Rules. These limits are designed to provide reasonable protection against harmful interference in a residential installation. This equipment generates, uses and can radiate radio frequency energy and, if not installed and used in accordance with the instructions, may cause harmful interference to radio communications. However, there is no guarantee that interference will not occur in a particular installation.

If this equipment does cause harmful interference to radio or television reception,which can be determined by turning the equipment off and on, the user is encouraged to try to correct the interference by one or more of the following measures:

- Reorient or relocate the receiving antenna.
- Increase the separation between the equipment and receiver.
- Connect the equipment into an outlet on a circuit different from that to which the receiver is connected.
- Consult the dealer or an experienced radio/TV technician for help.

To maintain compliance with FCC's RF Exposure guidelines, This equipment should be installed and operated with minimum distance between 20cm the radiator your body: Use only the supplied antenna.