

Prüfbericht-Nr.: <i>Test report no.:</i>	CN24YOHU 001	Auftrags-Nr.: <i>Order no.:</i>	48244922	Seite 1 von 38 Page 1 of 38
Kunden-Referenz-Nr.: <i>Client reference no.:</i>	N/A	Auftragsdatum: <i>Order date:</i>	2024-03-11	
Auftraggeber: <i>Client:</i>	Siemens Healthcare Diagnostics Inc. 2 Edgewater Drive Norwood, MA 02062 USA			
Prüfgegenstand: <i>Test item:</i>	Mobile Computing Device			
Bezeichnung / Typ-Nr.: <i>Identification / Type no.:</i>	PD470SH-B, PD470SH-N			
Auftrags-Inhalt: <i>Order content:</i>	FCC Part 15E Test report (WiFi 5GHz)			
Prüfgrundlage: <i>Test specification:</i>	FCC 47CFR Part 15: Subpart E Section 15.407			
Wareneingangsdatum: <i>Date of sample receipt:</i>	2024-03-14			
Prüfmuster-Nr.: <i>Test sample no.:</i>	A003675718-005 A003675718-002			
Prüfzeitraum: <i>Testing period:</i>	2024-03-20 - 2024-04-02			
Ort der Prüfung: <i>Place of testing:</i>	EMC/RF Taipei Testing Site			
Prüflaboratorium: <i>Testing laboratory:</i>	Taipei Testing Laboratories			
Prüfergebnis*: <i>Test result*:</i>	Pass			
überprüft von: <i>compiled by:</i>		genehmigt von: <i>authorized by:</i>		
Datum: <i>Date:</i>	2024-04-12	Ausstellungsdatum: <i>Issue date:</i>	2024-04-12	
Stellung / Position:	Anderson Chiu Senior Project Manager	Stellung / Position:	Brenda Chen Senior Project Manager	
Sonstiges / Other:	This report is to enable WLAN 5GHz band 2 and band 3 function. Only the tests for WLAN 5GHz band 2 and band 3 were evaluated. For the other test results, refer to report no.: 50278819 001.			
Zustand des Prüfgegenstandes bei Anlieferung: <i>Condition of the test item at delivery:</i>	Prüfmuster vollständig und unbeschädigt <i>Test item complete and undamaged</i>			
* Legende:	1 = sehr gut P(ass) = entspricht o.g. Prüfgrundlage(n)	2 = gut F(ail) = entspricht nicht o.g. Prüfgrundlage(n)	3 = befriedigend N/A = nicht anwendbar	4 = ausreichend N/T = nicht getestet
* Legend:	1 = very good P(ass) = passed a.m. test specification(s)	2 = good F(ail) = failed a.m. test specification(s)	3 = satisfactory N/A = not applicable	4 = sufficient N/T = not tested
Dieser Prüfbericht bezieht sich nur auf das o.g. Prüfmuster und darf ohne Genehmigung der Prüfstelle nicht auszugsweise vervielfältigt werden. Dieser Bericht berechtigt nicht zur Verwendung eines Prüfzeichens. <i>This test report only relates to the a. m. test sample. Without permission of the test center this test report is not permitted to be duplicated in extracts. This test report does not entitle to carry any test mark.</i>				

Prüfbericht-Nr.:
Test report no.:

CN24YOHU 001

Seite 2 von 38
Page 2 of 38

Anmerkungen
Remarks

1	<p>Alle eingesetzten Prüfmittel waren zum angegebenen Prüfzeitraum gemäß eines festgelegten Kalibrierungsprogramms unseres Prüfhauses kalibriert. Sie entsprechen den in den Prüfprogrammen hinterlegten Anforderungen. Die Rückverfolgbarkeit der eingesetzten Prüfmittel ist durch die Einhaltung der Regelungen unseres Managementsystems gegeben. Detaillierte Informationen bezüglich Prüfkonditionen, Prüfequipment und Messunsicherheiten sind im Prüflabor vorhanden und können auf Wunsch bereitgestellt werden.</p> <p><i>The equipment used during the specified testing period was calibrated according to our test laboratory calibration program. The equipment fulfils the requirements included in the relevant standards. The traceability of the test equipment used is ensured by compliance with the regulations of our management system. Detailed information regarding test conditions, equipment and measurement uncertainty is available in the test laboratory and could be provided on request.</i></p>
2	<p>Wie vertraglich vereinbart, wurde dieses Dokument nur digital unterzeichnet. Der TÜV Rheinland hat nicht überprüft, welche rechtlichen oder sonstigen diesbezüglichen Anforderungen für dieses Dokument gelten. Diese Überprüfung liegt in der Verantwortung des Benutzers dieses Dokuments. Auf Verlangen des Kunden kann der TÜV Rheinland die Gültigkeit der digitalen Signatur durch ein gesondertes Dokument bestätigen. Diese Anfrage ist an unseren Vertrieb zu richten. Eine Umweltgebühr für einen solchen zusätzlichen Service wird erhoben. Informationen zur Verifizierung der Authentizität unserer Dokumente erhalten Sie auf folgender Webseite: go.tuv.com/digital-signature</p> <p><i>As contractually agreed, this document has been signed digitally only. TUV Rheinland has not verified and unable to verify which legal or other pertaining requirements are applicable for this document. Such verification is within the responsibility of the user of this document. Upon request by its client, TUV Rheinland can confirm the validity of the digital signature by a separate document. Such request shall be addressed to our Sales department. An environmental fee for such additional service will be charged. For information on verifying the authenticity of our documents, please visit the following website: go.tuv.com/digital-signature</i></p>
3	<p>Prüfklausel mit der Note * wurden an qualifizierte Unterauftragnehmer vergeben und sind unter der jeweiligen Prüfklausel des Berichts beschrieben. Abweichungen von Prüfspezifikation(en) oder Kundenanforderungen sind in der jeweiligen Prüfklausel im Bericht aufgeführt.</p> <p><i>Test clauses with remark of * are subcontracted to qualified subcontractors and described under the respective test clause in the report. Deviations of testing specification(s) or customer requirements are listed in specific test clause in the report.</i></p>
4	<p>Die Entscheidungsregel für Konformitätserklärungen basierend auf numerischen Messergebnissen in diesem Prüfbericht basiert auf der "Null-Grenzwert-Regel" und der "Einfachen Akzeptanz" gemäß ILAC G8:2019 und IEC Guide 115:2021, es sei denn, in der auf Seite 1 dieses Berichts genannten angewandten Norm ist etwas anderes festgelegt oder vom Kunden gewünscht. Dies bedeutet, dass die Messunsicherheit nicht berücksichtigt wird und daher auch nicht im Prüfbericht angegeben wird. Zu weiteren Informationen bezüglich des Risikos durch diese Entscheidungsregel siehe ILAC G8:2019.</p> <p><i>The decision rule for statements of conformity, based on numerical measurement results, in this test report is based on the "Zero Guard Band Rule" and "Simple Acceptance" in accordance with ILAC G8:2019 and IEC Guide 115:2021, unless otherwise specified in the applied standard mentioned on Page 1 of this report or requested by the customer. This means that measurement uncertainty is not taken in account and hence also not declared in the test report. For additional information to the resulting risk based of this decision rule please refer to ILAC G8:2019.</i></p>

TEST SUMMARY

Report Section	FCC Clause	Test Item	Result
5.1.1	15.407(a) & 15.203	Antenna Requirement	Pass
5.1.2	15.407(a)	Maximum Conducted Output Power	Pass
5.1.3	15.407(h)(1)	Transmit Power Control (TPC)	Pass
5.1.4	15.407(a)	26 dB Bandwidth	Pass
5.1.4	2.1049	99% Occupied Bandwidth	Pass
-	15.407(e)	6 dB Bandwidth (U-NII-3 Band only)	N/A
5.1.5	15.407(g)	Frequency Stability	Pass
5.1.6	15.407(a)	Power Spectral Density	Pass
5.1.7	15.407(b) & 15.205 & 15.209	Radiated Spurious Emissions and Band Edges	Pass
5.1.8	15.407(h) & KDB 905462 D02	Dynamic Frequency Selection	Pass
5.2.1	15.207	Mains Conducted Emission	Pass

Note: Determining compliance based on the results of the compliance measurement, not taking into account measurement instrumentation uncertainty.

Contents

HISTORY OF THIS TEST REPORT	6
1. GENERAL REMARKS	7
1.1 COMPLEMENTARY MATERIALS	7
1.2 DECISION RULE OF CONFORMITY	7
2. TEST SITES	8
2.1 TEST LABORATORY	8
2.2 TEST FACILITY	8
2.3 TRACEABILITY	9
2.4 CALIBRATION	9
2.5 MEASUREMENT UNCERTAINTY	9
3. GENERAL PRODUCT INFORMATION	10
3.1 PRODUCT FUNCTION AND INTENDED USE	10
3.2 SYSTEM DETAILS AND RATINGS	10
3.3 NOISE GENERATING AND NOISE SUPPRESSING PARTS	11
3.4 SUBMITTED DOCUMENTS	11
4. TEST SET-UP AND OPERATION MODES	12
4.1 PRINCIPLE OF CONFIGURATION SELECTION	12
4.2 CARRIER FREQUENCY AND CHANNEL	13
4.3 TEST OPERATION AND TEST SOFTWARE	14
4.4 SPECIAL ACCESSORIES AND AUXILIARY EQUIPMENT	15
4.5 TEST SETUP DIAGRAM	16
4.6 DUTY CYCLE OF TEST SIGNAL	17
5. TEST RESULTS	18
5.1 TRANSMITTER REQUIREMENT & TEST SUITES	18
5.1.1 <i>Antenna Requirement</i>	<i>18</i>
5.1.2 <i>Maximum Conducted Output Power</i>	<i>19</i>
5.1.3 <i>Transmit Power Control (TPC)</i>	<i>22</i>
5.1.4 <i>26 dB Bandwidth and 99% Occupied Bandwidth</i>	<i>23</i>
5.1.5 <i>Frequency Stability Measurement</i>	<i>24</i>
5.1.6 <i>Power Spectral Density</i>	<i>26</i>
5.1.7 <i>Radiated Spurious Emissions</i>	<i>27</i>
5.1.8 <i>Dynamic Frequency Selection</i>	<i>32</i>
5.2 MAINS EMISSION	37
5.2.1 <i>Mains Conducted Emission</i>	<i>37</i>

Prüfbericht - Nr.: **CN24YOHU 001**
Test Report No.

Seite 5 von 38
Page 5 of 38

APPENDIX A - TEST RESULT OF CONDUCTED

APPENDIX B - TEST RESULT OF RADIATED EMISSIONS & MAINS CONDUCTED EMISSION

APPENDIX SP - PHOTOGRAPHS OF TEST SETUP

APPENDIX EP - PHOTOGRAPHS OF EUT

Prüfbericht - Nr.: **CN24YOHU 001**
Test Report No.

Seite 6 von 38
Page 6 of 38

HISTORY OF THIS TEST REPORT

Revision	Description	Date Issued
R01	Original Release	2024-04-12

1. General Remarks

1.1 Complementary Materials

All attachments are integral parts of this test report. This applies especially to the following appendix:

Appendix A - Test Result of Conducted

Appendix B - Test Result of Radiated Emissions & Mains Conducted Emission

Appendix SP - Photographs of Test Setup

Appendix EP - Photographs of EUT

Applied Standard and Test Levels

Radio
FCC 47CFR Part 15: Subpart E Section 15.407
FCC 47CFR Part 2: Subpart J Section 2.1049
ANSI C63.10:2013
KDB 789033 D02 General UNII Test Procedures New Rules v02r01
KDB 905462 D02 UNII DFS Compliance Procedures New Rules v02
KDB 662911 D01 Multiple Transmitter Output v02r01

1.2 Decision Rule of Conformity

The decision rule of conformity of this test report is following the requirements of the requested standard in the quotation, and agreed among testing laboratory and manufacturer (applicant) to exclude the consideration of Measurement Uncertainty, unless it is required by the specific standard.

2. Test Sites

2.1 Test Laboratory

Taipei Testing Laboratories

11F. No.758, Sec. 4, Bade Rd., Songshan Dist.
Taipei City 105
Taiwan (R.O.C.)

2.2 Test Facility

Taipei Testing Laboratories

No.458-18, Sec. 2, Fenliao Rd., Linkou Dist.,
New Taipei City 244
Taiwan (R.O.C.)
FCC Registration No.: 180491
ISED Registration No.: 25563

2.3 Traceability

All measurement equipment calibrations are traceable to NML(Taiwan)/NIST(USA) or where calibration is performed outside Taiwan, to equivalent nationally recognized standards organizations.

2.4 Calibration

Equipment requiring calibration is calibrated periodically in a suitably accredited Calibration Lab. Additionally all equipment is verified for proper performance on a regular basis using in house standards or comparisons.

2.5 Measurement Uncertainty

All measurement uncertainty values are shown with a coverage factor of $k=2$ to indicate a 95% level of confidence.

Emission Measurement Uncertainty

Parameter	Uncertainty
Radiated Emission (9 kHz ~ 30 MHz)	± 1.15 dB
Radiated Emission (30 MHz ~ 200 MHz)	± 1.32 dB
Radiated Emission (200 MHz ~ 1 GHz)	± 1.31 dB
Radiated Emission (1 GHz ~ 18 GHz)	± 1.53 dB
Radiated Emission (18 GHz ~ 40 GHz)	± 2.50 dB
Mains Conducted Emission	± 1.65 dB

3. General Product Information

3.1 Product Function and Intended Use

The EUT is a Mobile Computing Device. It contains a WLAN compatible module enabling the user to communicate data through a Wireless interface.

For details refer to the User Guide, Data Sheet and Circuit Diagram.

3.2 System Details and Ratings

Basic Information of EUT

Item	EUT information
Kind of Equipment/Test Item	Mobile Computing Device
Type Identification	PD470SH-B, PD470SH-N
FCC ID	2AUAM-PD470SH

Technical Specification of EUT

Item	EUT information
Operating Frequency	Band 2: 5260 MHz ~ 5320 MHz Band 3: 5500 MHz ~ 5700 MHz
Channel Number	Band 2: 4 for 802.11a, 802.11n HT20, 802.11ac VHT20 2 for 802.11n HT40, 802.11ac VHT40 1 for 802.11ac VHT80 Band 3: 8 for 802.11a, 802.11n HT20, 802.11ac VHT20 4 for 802.11n HT40, 802.11ac VHT40 1 for 802.11ac VHT80
Data Rate	802.11a: 54.0 / 48.0 / 36.0 / 24.0 / 18.0 / 12.0 / 9.0 / 6.0 Mbps 802.11n: up to MCS7 802.11ac: up to MCS9
Operation Voltage	3.8 Vdc (Battery) 5 Vdc (USB)
Modulation	OFDM (BPSK, QPSK, 16QAM, 64QAM, 256QAM)
Maximum Output Power (mW)	5260 ~ 5320 MHz: 23.82 5500 ~ 5720 MHz: 31.41
Maximum EIRP (mW)	5260 ~ 5320 MHz: 37.84 5500 ~ 5720 MHz: 51.52
DFS Mode	Slave without radar detection
Antenna Information	Refer to 5.1.1
Accessory Device	Refer to 4.4

Prüfbericht - Nr.: CN24YOHU 001
*Test Report No.*Seite 11 von 38
Page 11 of 38

Note:

1. All models are listed as below.

Main Model (Test model)	Series Model	Difference
PD470SH-B	PD470SH-N	PD470SH-B and PD470SH-N use the same motherboard and RF Chip, the difference between PD470SH-B and PD470SH-N is that PD470SH-B more than PD470SH-N a barcode scanner function.

3.3 Noise Generating and Noise Suppressing Parts

Refer to the Circuit Diagram.

3.4 Submitted Documents

- Circuit Diagram
- Instruction Manual
- Rating Label
- Technical Description

4. Test Set-up and Operation Modes

4.1 Principle of Configuration Selection

The test modes were adapted accordingly in reference to the instructions for use.

During testing, Channel and Power Controlling Software provided by the customer was used to control the operating channel as well as the output power level. The RF output power selection is for the setting of RF output expected by the customer and is going to be fixed on the firmware of the final end product.

Table for Parameters of Test Software Setting

802.11a		802.11n HT20 802.11ac VHT20		802.11n HT40 802.11ac VHT40		802.11ac VHT80	
Channel	Power Setting	Channel	Power Setting	Channel	Power Setting	Channel	Power Setting
52	18	52	17.5	54	22.5	58	18.5
60	19	60	18	62	19.5	106	18
64	19	64	18	102	18.5		
100	21	100	21	110	24		
116	21	116	21.5	134	22		
140	20.5	140	19.5				

4.2 Carrier Frequency and Channel

Band	Channel	Frequency (MHz)	802.11a 802.11n HT20 802.11ac VHT20	802.11n HT40 802.11ac VHT40	802.11ac VHT80
U-NII-2A (Band 2)	52	5260	V		
	54	5270		V	
	56	5280	V		
	58	5290			V
	60	5300	V		
	62	5310		V	
	64	5320	V		
U-NII-2C (Band 3)	100	5500	V		
	102	5510		V	
	104	5520	V		
	106	5530			V
	108	5540	V		
	110	5550		V	
	112	5560	V		
	116	5580	V		
	118	5590		V	
	120	5600			
	122	5610			
	124	5620			
	126	5630			
	128	5640			
	132	5660	V		
	134	5670		V	
136	5680	V			
140	5700	V			

4.3 Test Operation and Test Software

Setup for testing: The test sample itself is equipped with a touch screen. It was used to enable the operation modes listed as below.

The samples were used as follows:

A003675718-005

A003675718-002

Full test was applied on all test modes, but only worst case was shown.

EUT Configure Mode	Applicable To				Description
	Antenna Port Conducted Measurement	Radiated Spurious Emissions above 1 GHz	Radiated Spurious Emissions below 1 GHz	Mains Conducted Emission	
-	√	√	√	√	-

Note:

1. The EUT had been pre-tested on the positioned of each 3 axis. The worst case was found when position on **Z-plane**.
2. "-" means no effect.

Antenna Port Conducted Measurement

- Pre-Scan full test was applied on all test modes, but only worst case was shown.
- Following channel(s) was (were) selected for the final test as listed below.

EUT Configure Mode	Mode	Frequency (MHz)	Available Channel	Tested Channel	Date Rate (Mbps)
-	802.11a	5260-5320	52 to 64	52, 60, 64	6.0
-		5500-5700	100 to 140	100, 116, 140	
-	802.11n HT20 (Power only)	5260-5320	52 to 64	52, 60, 64	MCS0
-		5500-5700	100 to 140	100, 116, 140	
-	802.11n HT40 (Power only)	5260-5320	54 to 62	54, 62	MCS0
-		5500-5700	102 to 134	102, 110, 134	
-	802.11ac VHT20	5260-5320	52 to 64	52, 60, 64	NSS1 MCS0
-		5500-5700	100 to 140	100, 116, 140	
-	802.11ac VHT40	5260-5320	54 to 62	54, 62	NSS1 MCS0
-		5500-5700	102 to 134	102, 110, 134	
-	802.11ac VHT80	5260-5320	58	58	NSS1 MCS0
-		5500-5700	106	106	

Radiated Spurious Emissions (Above 1 GHz)

- Pre-Scan full test was applied on all test modes, but only worst case was shown.
- Following channel(s) was (were) selected for the final test as listed below.

EUT Configure Mode	Mode	Frequency (MHz)	Available Channel	Tested Channel	Date Rate (Mbps)
-	802.11a	5260-5320	52 to 64	52, 60, 64	6.0
-		5500-5700	100 to 140	100, 116, 140	
-	802.11ac VHT20	5260-5320	52 to 64	52, 60, 64	NSS1 MCS0
-		5500-5700	100 to 140	100, 116, 140	
-	802.11ac VHT40	5260-5320	54 to 62	54, 62	NSS1 MCS0
-		5500-5700	102 to 134	102, 110, 134	
-	802.11ac VHT80	5260-5320	58	58	NSS1 MCS0
-		5500-5700	106	106	

Prüfbericht - Nr.: CN24YOHU 001
Test Report No.

 Seite 15 von 38
 Page 15 of 38

Radiated Spurious Emissions (Below 1 GHz)

- Pre-Scan full test was applied on all test modes, but only worst case was shown.
- Following channel(s) was (were) selected for the final test as listed below.

EUT Configure Mode	Mode	Frequency (MHz)	Available Channel	Tested Channel	Date Rate (Mbps)
-	802.11ac VHT40	5500-5700	102 to 134	110	NSS1 MCS0

Mains Conducted Emission Test

- Pre-Scan full test was applied on all test modes, but only worst case was shown.
- Following channel(s) was (were) selected for the final test as listed below.

EUT Configure Mode	Mode	Frequency (MHz)	Available Channel	Tested Channel	Date Rate (Mbps)
-	802.11ac VHT40	5500-5700	102 to 134	110	NSS1 MCS0

Test Condition

Test Item	Ambient Temperature	Relative Humidity	Tested by
Conducted Measurement	22.9-24.3 °C	60-71 %	Andy Chen
Radiated Spurious Emissions above 1 GHz	23.7-24.6 °C	52-55 %	Roger Liao
Radiated Spurious Emissions below 1 GHz	23.7-24.6 °C	52-55 %	Roger Liao
Mains Conducted Emission	20.1-25.9 °C	50.2-58.9 %	Roger Liao

4.4 Special Accessories and Auxiliary Equipment

The product has been tested together with the following additional accessories:

Accessory of EUT

No.	Product	Brand	Model	Description
-	Battery	Xiamen Releader	PD470	3.8 Vdc, 4000 mAh

Support Unit

Support Unit								
No	Description	Brand	Model	S/N	Shielded	Ferrite Core (Qty)	Length (cm)	Remark
1	Adapter	OPPO	VC56JACH	N/A	-	-	-	--
2	USB to Micro	TUV	TUV-01	N/A	NO	NO	150	--

4.5 Test Setup Diagram

<Radiated Spurious Emissions mode>

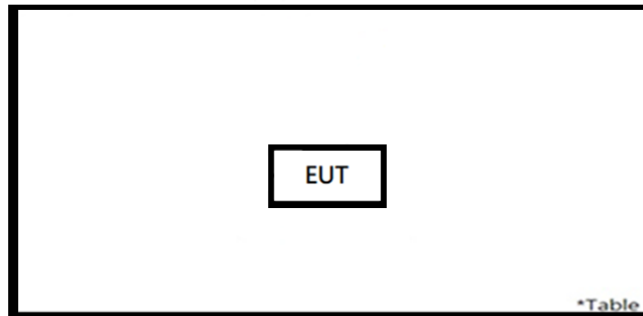

<Mains Conducted Emission mode>

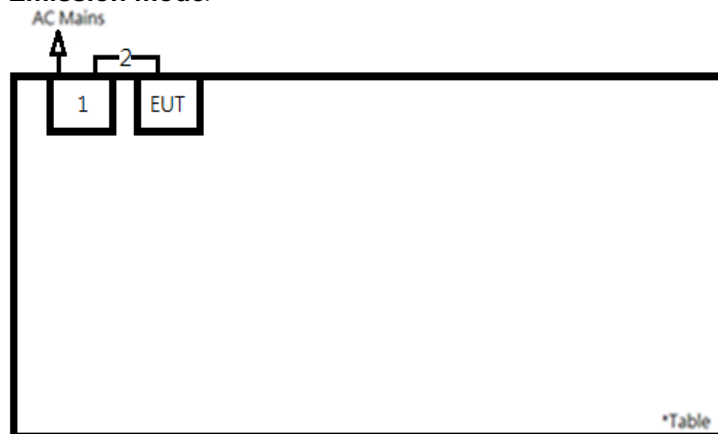

4.6 Duty Cycle of Test Signal

Mode	On + Off Time (ms)	On Time (ms)	Duty Cycle (%)	Duty Factor (dB)
802.11a	1.44	1.39	96.59	0.15
802.11ac VHT20	1.36	1.31	96.65	0.15
802.11ac VHT40	0.70	0.65	93.30	0.30
802.11ac VHT80	0.37	0.32	87.80	0.56

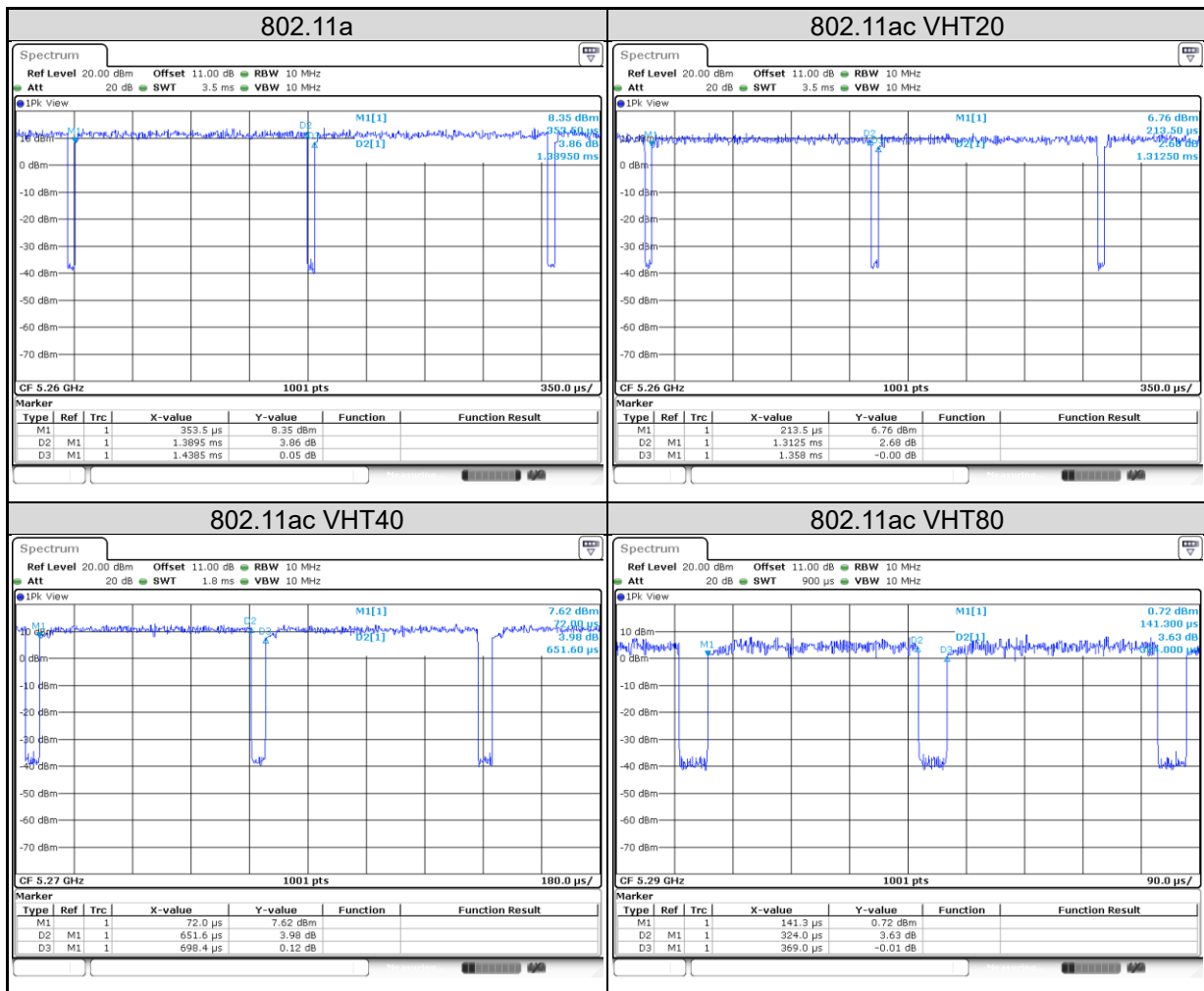

5. Test Results

5.1 Transmitter Requirement & Test Suites

5.1.1 Antenna Requirement

Requirement Use of approved antennas only

According to the manufacturer declaration, the EUT's antenna specifications are described as below. The antenna is used with no possibility of replacement with a non-approved antenna by the end-user. Therefore, the EUT is considered to comply with this provision.

PCB antenna with 2.01 dBi gain (5260 ~ 5320 MHz)

PCB antenna with 2.15 dBi gain (5500 ~ 5700 MHz)

Refer to EUT photo for details.

Prüfbericht - Nr.: CN24YOHU 001
Test Report No.

 Seite 19 von 38
 Page 19 of 38

5.1.2 Maximum Conducted Output Power

Limit

Operation Band	EUT Category	Limit
U-NII-1	Outdoor Access Point	1 Watt (30 dBm) (Max. e.i.r.p \leq 125 mW (21 dBm) at any elevation angle above 30 degrees as measured from the horizon)
	Fixed point-to-point Access Point	1 Watt (30 dBm)
	Indoor Access Point	1 Watt (30 dBm)
	Mobile and Portable client device	250 mW (24 dBm)
U-NII-2A	---	250 mW (24 dBm) or 11 dBm + 10 log B*
U-NII-2C	---	250 mW (24 dBm) or 11 dBm + 10 log B*
U-NII-3	---	1 Watt (30 dBm)

Note: B* is the 26 dB emission bandwidth in megahertz

Kind of Test Site Shielded room

Test Setup

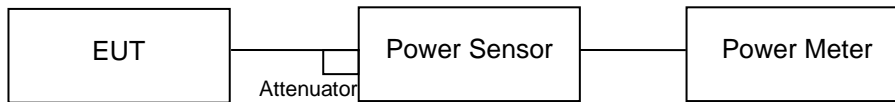

Test Instruments

Kind of Equipment	Manufacturer	Type	S/N	Calibration Date	Calibration Due Date	Test Date	
						From	Until
Power Meter	Anritsu	ML2495A	1901008	2024/03/12	2025/03/12	2024/3/25	2024/4/2
Power Sensor	Anritsu	MA2411B	1725269	2024/03/12	2025/03/12	2024/3/25	2024/4/2

Test Procedures

Method PM is used to perform output power measurement, trigger and gating function of wide band power meter is enabled to measure max output power of TX on burst and set the detector to AVERAGE. Duty factor is not added to measured value.

Test Result
<802.11a>

Channel	Channel Frequency (MHz)	Average Output Power		Limit (dBm)
		(dBm)	(mW)	
52	5260	10.04	10.09	24.00
60	5300	10.81	12.05	24.00
64	5320	10.79	11.99	24.00
100	5500	12.13	16.33	24.00
116	5580	12.46	17.62	24.00
140	5700	12.37	17.26	24.00

Note:
For U-NII-2A, U-NII-2C Band:

1. $11 \text{ dBm} + 10\log(26.37) = 25.21 \text{ dBm} > 24 \text{ dBm}$.
2. $11 \text{ dBm} + 10\log(33.21) = 26.21 \text{ dBm} > 24 \text{ dBm}$.
3. $11 \text{ dBm} + 10\log(31.13) = 25.93 \text{ dBm} > 24 \text{ dBm}$.
4. $11 \text{ dBm} + 10\log(36.32) = 26.60 \text{ dBm} > 24 \text{ dBm}$.
5. $11 \text{ dBm} + 10\log(37.32) = 26.72 \text{ dBm} > 24 \text{ dBm}$.
6. $11 \text{ dBm} + 10\log(37.64) = 26.76 \text{ dBm} > 24 \text{ dBm}$.

<802.11n HT20>

Channel	Channel Frequency (MHz)	Average Output Power		Limit (dBm)
		(dBm)	(mW)	
52	5260	8.71	7.43	24.00
60	5300	9.16	8.24	24.00
64	5320	9.82	9.59	24.00
100	5500	12.33	17.10	24.00
116	5580	11.88	15.42	24.00
140	5700	11.04	12.71	24.00

<802.11n HT40>

Channel	Channel Frequency (MHz)	Average Output Power		Limit (dBm)
		(dBm)	(mW)	
54	5270	13.64	23.12	24.00
62	5310	10.87	12.22	24.00
102	5510	10.29	10.69	24.00
110	5550	14.85	30.55	24.00
134	5670	13.81	24.04	24.00

<802.11ac VHT20>

Channel	Channel Frequency (MHz)	Average Output Power		Limit (dBm)
		(dBm)	(mW)	
52	5260	8.85	7.67	24.00
60	5300	9.29	8.49	24.00
64	5320	9.94	9.86	24.00
100	5500	12.44	17.54	24.00
116	5580	12.02	15.92	24.00
140	5700	11.17	13.09	24.00

Note:
For U-NII-2A, U-NII-2C Band:

1. $11 \text{ dBm} + 10\log(26.77) = 25.28 \text{ dBm} > 24 \text{ dBm}$.
2. $11 \text{ dBm} + 10\log(30.25) = 25.81 \text{ dBm} > 24 \text{ dBm}$.
3. $11 \text{ dBm} + 10\log(27.93) = 25.46 \text{ dBm} > 24 \text{ dBm}$.
4. $11 \text{ dBm} + 10\log(36.16) = 26.58 \text{ dBm} > 24 \text{ dBm}$.
5. $11 \text{ dBm} + 10\log(36.88) = 26.67 \text{ dBm} > 24 \text{ dBm}$.
6. $11 \text{ dBm} + 10\log(35.36) = 26.49 \text{ dBm} > 24 \text{ dBm}$.

<802.11ac VHT40>

Channel	Channel Frequency (MHz)	Average Output Power		Limit (dBm)
		(dBm)	(mW)	
54	5270	13.77	23.82	24.00
62	5310	11.02	12.65	24.00
102	5510	10.42	11.02	24.00
110	5550	14.97	31.41	24.00
134	5670	13.94	24.77	24.00

Note:
For U-NII-2A, U-NII-2C Band:

1. $11 \text{ dBm} + 10\log(72.01) = 29.57 \text{ dBm} > 24 \text{ dBm}$.
2. $11 \text{ dBm} + 10\log(52.35) = 28.19 \text{ dBm} > 24 \text{ dBm}$.
3. $11 \text{ dBm} + 10\log(45.55) = 27.59 \text{ dBm} > 24 \text{ dBm}$.
4. $11 \text{ dBm} + 10\log(75.76) = 29.79 \text{ dBm} > 24 \text{ dBm}$.
5. $11 \text{ dBm} + 10\log(74.65) = 29.73 \text{ dBm} > 24 \text{ dBm}$.

<802.11ac VHT80>

Channel	Channel Frequency (MHz)	Average Output Power		Limit (dBm)
		(dBm)	(mW)	
58	5290	10.23	10.54	24.00
106	5530	9.94	9.86	24.00

Note:
For U-NII-2A, U-NII-2C Band:

1. $11 \text{ dBm} + 10\log(119.40) = 31.77 \text{ dBm} > 24 \text{ dBm}$.
2. $11 \text{ dBm} + 10\log(98.46) = 30.93 \text{ dBm} > 24 \text{ dBm}$.

5.1.3 Transmit Power Control (TPC)

Requirement

U-NII devices operating in the 5.25-5.35 GHz band and the 5.47-5.725 GHz band shall employ a TPC mechanism. The U-NII device is required to have capability to operate at least 6 dB below the mean EIRP value of 30 dBm. A TPC mechanism is not required for systems with an e.i.r.p of less than 500 mW.

Maximum EIRP of this device is 51.52 mW which is less than 500mW, therefore it's not require TPC function.

TPC	E.I.R.P	15.407(h)(1)
	> 500mW	The TPC mechanism is required for system with an E.I.R.P. of above 500mW
V	< 500mW	-

Prüfbericht - Nr.: CN24YOHU 001
Test Report No.

 Seite 23 von 38
 Page 23 of 38

5.1.4 26 dB Bandwidth and 99% Occupied Bandwidth

Kind of Test Site Shielded room

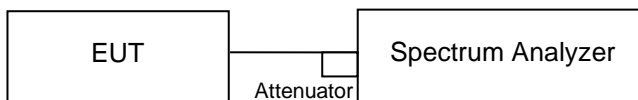
Test Setup

Test Instruments

Kind of Equipment	Manufacturer	Type	S/N	Calibration Date	Calibration Due Date	Test Date	
						From	Until
Spectrum Analyzer	R&S	FSV	101512	2024/02/22	2025/02/20	2024/3/25	2024/4/2
Thermal Chamber	Giant Force	GHT-150-40-CP-SD	MAA1902-010	2024/02/22	2025/02/20	2024/3/25	2024/4/2

Test Procedure

- a. Set RBW = approximately 1% of the emission bandwidth.
- b. Set the VBW > RBW.
- c. Detector = Peak.
- d. Trace mode = max hold.
- e. Measure the maximum width of the emission that is 26 dB down from the peak of the emission. Compare this with the RBW setting of the analyzer. Readjust RBW and repeat measurement as needed until the RBW/EBW ratio is approximately 1%.
- f. For 99% Bandwidth Measurement, the transmitter output was connected to the spectrum analyzer through an attenuator. The bandwidth of the fundamental frequency was measured by spectrum analyzer with resolution bandwidth in the range of 1% to 5% of the anticipated emission bandwidth, and a video bandwidth at least 3x the resolution bandwidth and set the detector to PEAK. The width of a frequency band such that, below the lower and above the upper frequency limits, the mean powers emitted are each equal to a specified percentage 0.5% of the total mean power of a given emission.

Test Results

Please refer to Appendix A

5.1.5 Frequency Stability Measurement

Kind of Test Site Shielded room

Test Setup

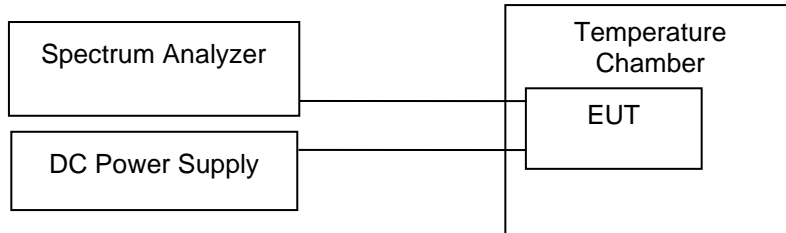

Test Instruments

Kind of Equipment	Manufacturer	Type	S/N	Calibration Date	Calibration Due Date	Test Date	
						From	Until
Spectrum Analyzer	R&S	FSV	101512	2024/02/22	2025/02/20	2024/3/25	2024/4/2
Thermal Chamber	Giant Force	GHT-150-40-CP-SD	MAA1902-010	2024/02/22	2025/02/20	2024/3/25	2024/4/2

Test Procedure

- a. To ensure emission at the band edge is maintained within the authorized band, those values shall be measured by radiation emissions at upper and lower frequency points, and finally compensated by frequency deviation as procedures below.
- b. The EUT was operated at the maximum output power, and connected to the spectrum analyzer, which is set to maximum hold function and peak detector. The peak value of the power envelope was measured and noted. The upper and lower frequency points were respectively measured relatively 10 dB lower than the measured peak value.
- c. The frequency deviation was calculated by adding the upper frequency point and the lower frequency point divided by two. Those detailed values of frequency deviation are provided in table below.

Prüfbericht - Nr.: CN24YOHU 001
Test Report No.
Test Results

Frequency (MHz)	5320			
Voltage (V)	Measurement Frequency (MHz)			Max. Deviation (ppm)
4.1	5319.96353			6.855
3.8	5319.97077			5.494
3.45	5319.96469			6.637
Temperature (°C)	Measurement Frequency (MHz)			
	0 Minute	2 Minute	5 Minute	10 Minute
50	5319.95253	5319.94964	5319.94906	5319.94906
40	5319.956956	5319.962191	5319.96861	5319.970767
30	5319.970411	5319.970668	5319.968362	5319.960132
20	5319.97077	5319.96324	5319.96035	5319.95861
10	5319.972102	5319.988663	5319.983048	5319.967507
0	5319.987194	5319.98534	5319.957156	5319.957292
-10	5319.954372	5319.974947	5319.972824	5319.95509
-20	5319.99074	5319.99219	5319.99016	5319.98784
Max. Deviation (ppm)	8.923	9.466	9.575	9.575

5.1.6 Power Spectral Density

Limit

For the 5.15~5.25GHz Bands:

For mobile and portable client devices in the 5.15~5.25GHz band, the Maximum Power spectral density shall not exceed 11dBm/MHz. For an indoor access point operating in the band 5.15~5.25GHz, the maximum power spectral density shall not exceed 17dBm/MHz.

For the 5.25~5.35GHz and 5.47~5.725GHz Bands:

The maximum power spectral density shall not exceed 11dBm/MHz.

For the 5.745~5.85GHz Bands:

The maximum power spectral density shall not exceed 30dBm/500kHz.

Kind of Test Site Shielded room

Test Setup

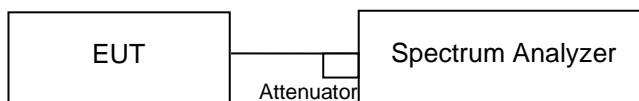

Test Instruments

Kind of Equipment	Manufacturer	Type	S/N	Calibration Date	Calibration Due Date	Test Date	
						From	Until
Spectrum Analyzer	R&S	FSV	101512	2024/02/22	2025/02/20	2024/3/25	2024/4/2
Thermal Chamber	Giant Force	GHT-150-40-CP-SD	MAA1902-010	2024/02/22	2025/02/20	2024/3/25	2024/4/2

Test Procedure

For U-NII-1, U-NII-2A, U-NII-2C band:

Using method SA-2

1. Set span to encompass the entire emission bandwidth (EBW) of the signal.
2. Set RBW = 1 MHz, Set VBW ≥ 3 MHz, Detector = RMS
3. Sweep time = auto, trigger set to "free run".
4. Trace average at least 100 traces in power averaging mode.
5. Record the max value and add 10 log (1/duty cycle)

Test Results

Please refer to Appendix A

5.1.7 Radiated Spurious Emissions

Limit

Radiated emissions which fall in the restricted bands, as defined in §15.205(a), must comply with the radiated emission limits specified in §15.209(a).

Emissions radiated outside the restricted and authorized frequency bands must either comply with the radiated emission limits specified for the restricted bands or in §15.407(b).

Kind of Test Site 3m Semi-Anechoic Chamber

Test Setup

<Radiated Emissions below 30 MHz>

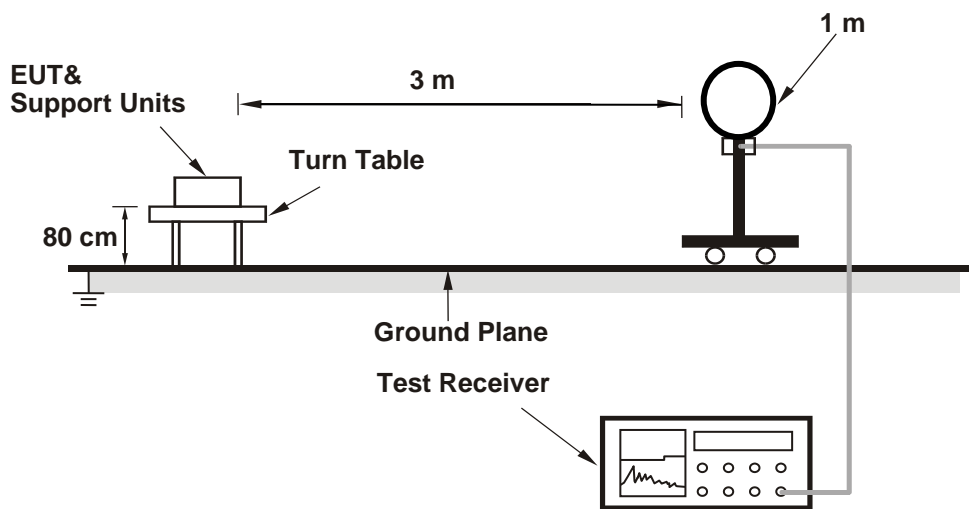

<Radiated Emissions 30 MHz to 1 GHz>

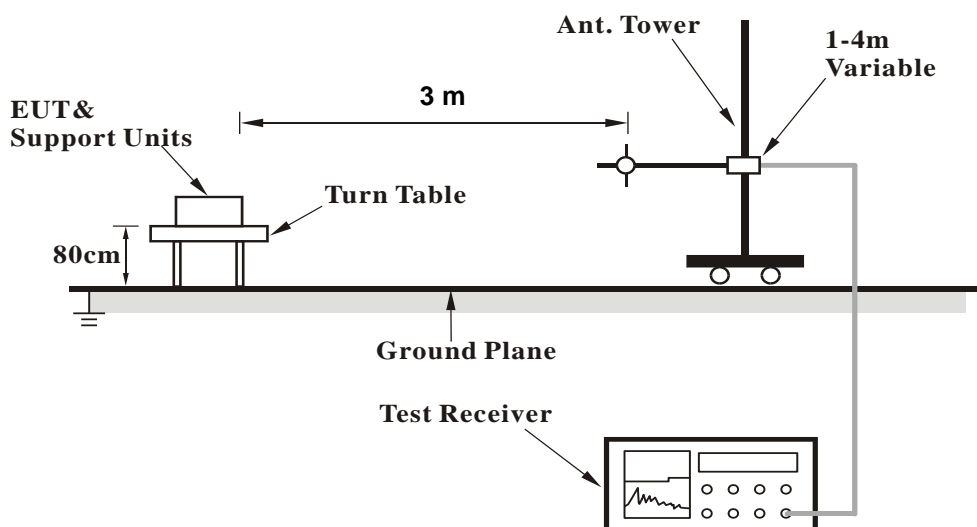

<Radiated Emissions above 1 GHz>

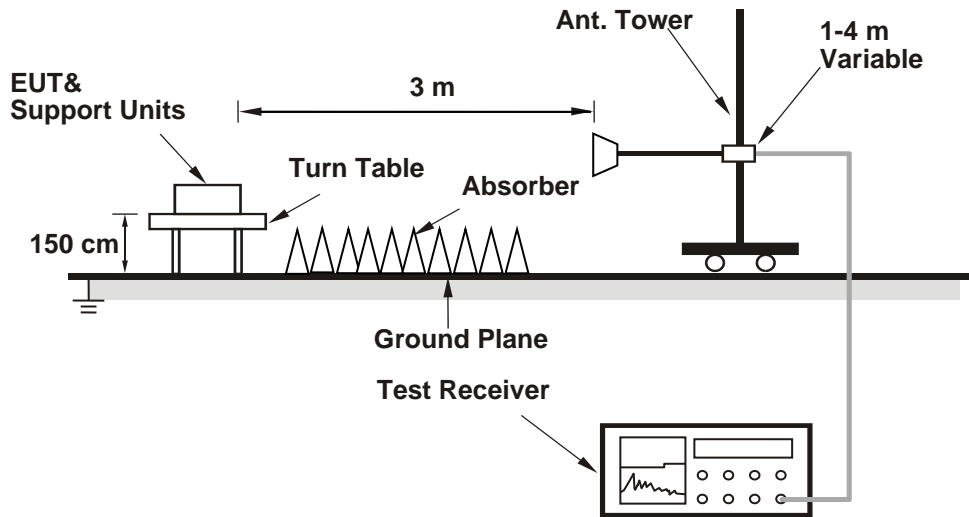

For the actual test configuration, please refer to the attached file (Test Setup Photo).

Prüfbericht - Nr.: CN24YOHU 001
Test Report No.
Test Instruments

Test Period: 2024-03-20 ~ 2024-03-26

Kind of Equipment	Manufacturer	Type	S/N	Calibration Date	Calibration Due Date
Above 1 GHz					
Signal Analyzer	R&S	FSV40	101509	2023/4/26	2024/4/24
Horn Antenna	ETS-Lindgren	3117	00218929	2023/11/17	2024/11/15
Horn Antenna	SCHWARZBECK	BBHA 9170	00890	2023/5/4	2024/5/2
HF-AMP + AC source	EMCI	EM01G18GA	980657	2024/1/24	2025/1/22
HF-AMP + AC source	EMCI	EMC184045SE	980656	2024/1/18	2025/1/16
Test Software	Audix E3	15914a_20191 106 tuv	PK-001087	N/A	N/A
30 MHz ~ 1 GHz					
Receiver	R&S	ESR7	102109	2024/2/22	2025/2/20
Bilog Antenna	SCHWARZBECK	VULB-9168	00951	2023/3/31	2024/3/29
LF-AMP	Agilent	8447D	2727A05146	2024/1/24	2025/1/22
Test Software	Audix E3	15914a_20191 106 tuv	PK-001087	N/A	N/A
Below 30 MHz					
Receiver	R&S	ESR7	102109	2024/1/24	2025/1/22
Loop Antenna	SCHWARZBECK	FMZB 1519B	00215	2024/1/4	2025/1/2
Test Software	Audix E3	15914a_20191 106 tuv	PK-001087	N/A	N/A

Test Procedures**For Radiated Emissions below 30 MHz**

- a. The EUT was placed on the top of a rotating table 0.8 meters above the ground at a 3 meter chamber room. The table was rotated 360 degrees to determine the position of the highest radiation.
- b. The EUT was set 3 meters away from the interference-receiving antenna, which was mounted on the top of a variable-height antenna tower.
- c. Parallel (OPEN), perpendicular (CLOSE), and ground-parallel (GROUND) orientations of the antenna are set to make the measurement.
- d. For each suspected emission, the EUT was arranged to its worst case and the rotatable table was turned from 0 degrees to 360 degrees to find the maximum reading.
- e. The test-receiver system was set to Quasi-Peak Detect Function and Specified Bandwidth with Maximum Hold Mode.

Note:

1. The resolution bandwidth and video bandwidth of test receiver/spectrum analyzer is 9 kHz at frequency below 30 MHz.
2. All modes of operation were investigated and the worst-case emissions are reported.

For Radiated Emissions above 30 MHz

- a. The EUT was placed on the top of a rotating table 0.8 meters (for 30 MHz ~ 1 GHz) / 1.5 meters (for above 1 GHz) above the ground at 3 meter chamber room for test. The table was rotated 360 degrees to determine the position of the highest radiation.
- b. The EUT was set 3 meters away from the interference-receiving antenna, which was mounted on the top of a variable-height antenna tower.
- c. The height of antenna is varied from one meter to four meters above the ground to determine the maximum value of the field strength. Both horizontal and vertical polarizations of the antenna are set to make the measurement.
- d. For each suspected emission, the EUT was arranged to its worst case and then the antenna was tuned to heights from 1 meter to 4 meters and the rotatable table was turned from 0 degrees to 360 degrees to find the maximum reading.
- e. The test-receiver system was set to quasi-peak detect function and specified bandwidth with maximum hold mode when the test frequency is below 1 GHz.
- f. The test-receiver system was set to peak and average detected function and specified bandwidth with maximum hold mode when the test frequency is above 1 GHz. If the peak reading value also meets average limit, measurement with the average detector is unnecessary.

Note:

1. The resolution bandwidth and video bandwidth of test receiver/spectrum analyzer is 120 kHz for Quasi-peak detection (QP) or Peak detection (PK) at frequency below 1 GHz.
2. The resolution bandwidth of test receiver/spectrum analyzer is 1 MHz and the video bandwidth is 3 MHz for Peak detection (PK) at frequency above 1 GHz.
3. The resolution bandwidth of test receiver/spectrum analyzer is 1 MHz and the video bandwidth is $\geq 1/T$ (Duty cycle < 98 %) or 10 Hz (Duty cycle ≥ 98 %) for Average detection (AV) at frequency above 1 GHz.
4. All modes of operation were investigated and the worst-case emissions are reported.
5. The Radiated Emissions testing was performed in the X(E1), Y(H) and Z(E2) axis orientation. The worst-case Axis orientation is recorded in this test report.
6. The emission levels of other frequencies (including the 10th harmonic of the highest fundamental frequency) are very lower than the limit and are not shown in the test report.

Prüfbericht - Nr.: **CN24YOHU 001**
Test Report No.

Seite 31 von 38
Page 31 of 38

Test Results

Factor (dB/m) = Antenna Factor (dB/m) + Cable Loss (dB) – Amplifier (dB)

Level (dBuV/m) = Reading (dBuV) + Factor (dB/m)

Please refer to Appendix B.

5.1.8 Dynamic Frequency Selection

Limit

<DFS Detection Thresholds for Master Devices and Client Devices with Radar Detection>

Maximum Transmit Power	Value (See Notes 1, 2, and 3)
EIRP ≥ 200 milliwatt	-64 dBm
EIRP < 200 milliwatt and power spectral density < 10 dBm/MHz	-62 dBm
EIRP < 200 milliwatt that do not meet the power spectral density requirement	-64 dBm
Note 1: This is the level at the input of the receiver assuming a 0 dBi receive antenna. Note 2: Throughout these test procedures an additional 1 dB has been added to the amplitude of the test transmission waveforms to account for variations in measurement equipment. This will ensure that the test signal is at or above the detection threshold level to trigger a DFS response. Note 3: EIRP is based on the highest antenna gain. For MIMO devices refer to KDB Publication 662911 D01.	

<DFS Response Requirement Values>

Parameter	Value
<i>Non-occupancy period</i>	Minimum 30 minutes
<i>Channel Availability Check Time</i>	60 seconds
<i>Channel Move Time</i>	10 seconds See Note 1.
<i>Channel Closing Transmission Time</i>	200 milliseconds + an aggregate of 60 milliseconds over remaining 10 second period. See Notes 1 and 2.
<i>U-NII Detection Bandwidth</i>	Minimum 100% of the U-NII 99% transmission power bandwidth. See Note 3.
Note 1: <i>Channel Move Time and the Channel Closing Transmission Time</i> should be performed with Radar Type 0. The measurement timing begins at the end of the Radar Type 0 burst. Note 2: The <i>Channel Closing Transmission Time</i> is comprised of 200 milliseconds starting at the beginning of the <i>Channel Move Time</i> plus any additional intermittent control signals required to facilitate a <i>Channel move</i> (an aggregate of 60 milliseconds) during the remainder of the 10 second period. The aggregate duration of control signals will not count quiet periods in between transmissions. Note 3: During the <i>U-NII Detection Bandwidth</i> detection test, radar type 0 should be used. For each frequency step the minimum percentage of detection is 90 percent. Measurements are performed with no data traffic.	

Kind of Test Site

Shielded room

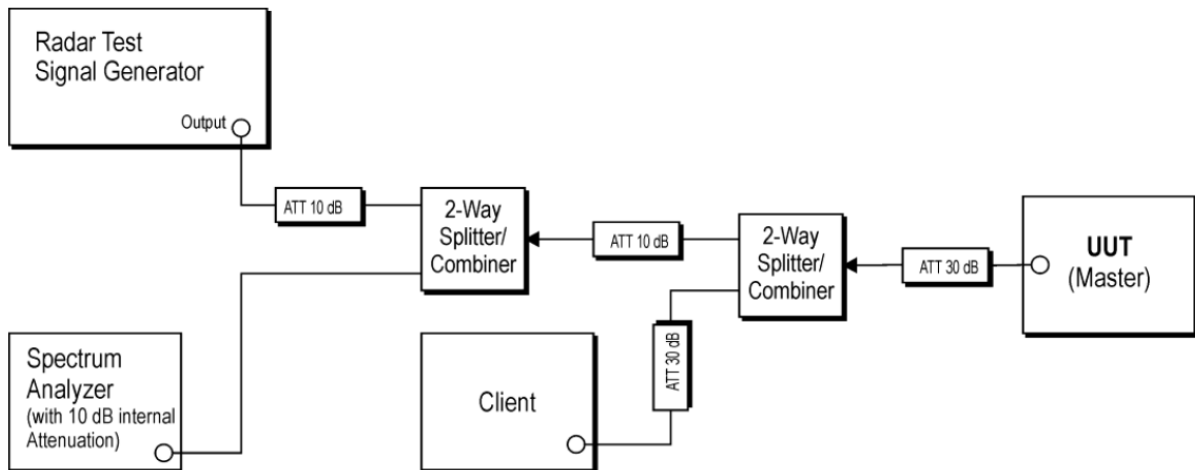
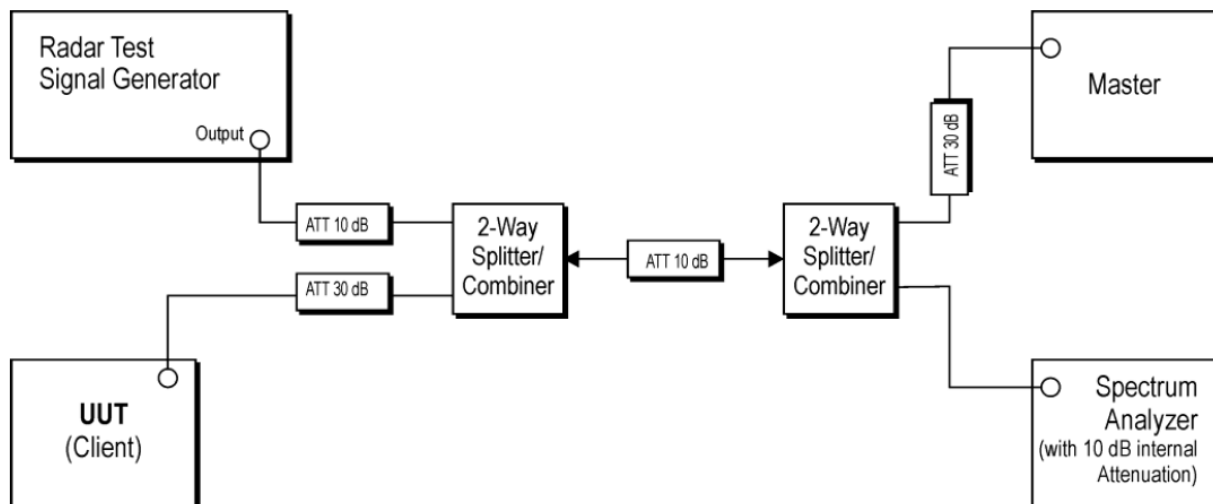
Test Setup
<Setup for Master with injection at the Master>

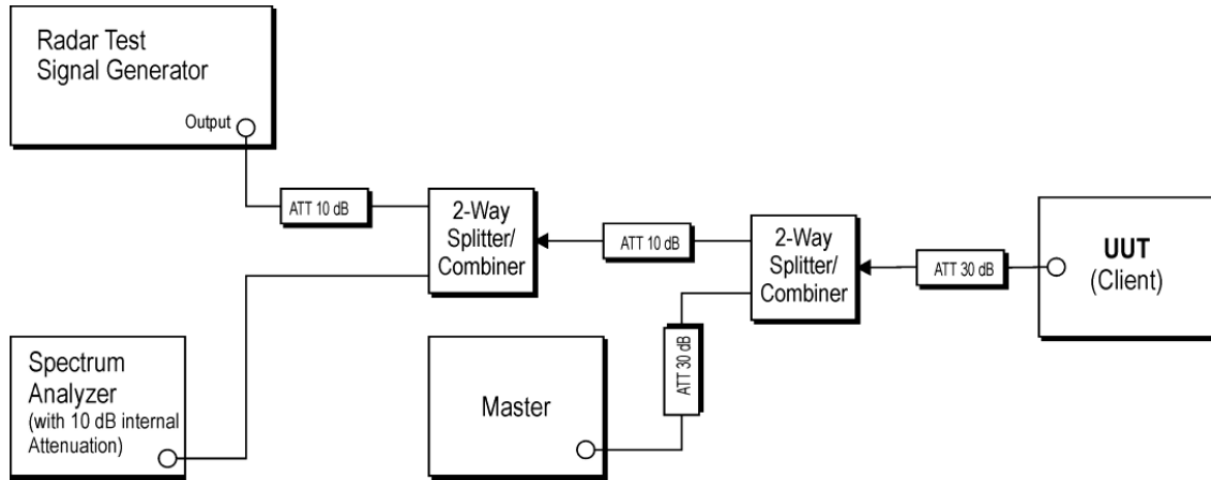
<Setup for Client with injection at the Master>

<Setup for Client with injection at the Client>

Test Instruments

Kind of Equipment	Manufacturer	Type	S/N	Calibration Date	Calibration Due Date	Test Date	
						From	Until
Spectrum Analyzer	Keysight	N9000B	MY62361339	2024/01/25	2025/01/23	2024/3/23	2024/3/23
EXG Vector Signal Generator	Keysight	N5172B	MY61253270	2023/12/22	2024/12/20	2024/3/23	2024/3/23
Frequency Extender	Keysight	N5182BX07	MY61500182	2023/12/22	2024/12/20	2024/3/23	2024/3/23

Requirement

Requirement	Operational Mode	
	Master Device or Client with Radar Detection	Client Without Radar Detection
<i>DFS Detection Threshold</i>	Yes	Not required
<i>Channel Closing Transmission Time</i>	Yes	Yes
<i>Channel Move Time</i>	Yes	Yes
<i>U-NII Detection Bandwidth</i>	Yes	Not required

Additional requirements for devices with multiple bandwidth modes	Master Device or Client with Radar Detection	Client Without Radar Detection
<i>U-NII Detection Bandwidth and Statistical Performance Check</i>	All BW modes must be tested	Not required
<i>Channel Move Time and Channel Closing Transmission Time</i>	Test using widest BW mode available	Test using the widest BW mode available for the link
<i>All other tests</i>	Any single BW mode	Not required

Note: Frequencies selected for statistical performance check (Section 7.8.4) should include several frequencies within the radar detection bandwidth and frequencies near the edge of the radar detection bandwidth. For 802.11 devices it is suggested to select frequencies in each of the bonded 20 MHz channels and the channel center frequency.

Test Results
<802.11ac VHT80>

Non-occupancy period

Channel (MHz)	Limit (minute)	Result
5530	30	Pass

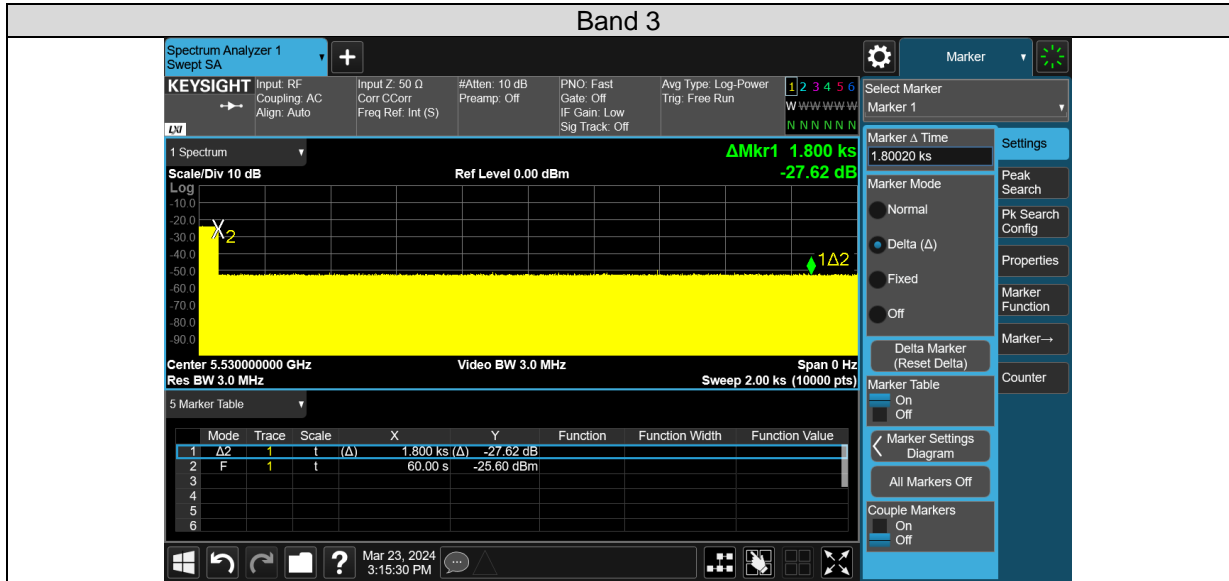

Channel Moving Time

Channel (MHz)	Channel Move Time (s)	Limit (s)	Result
5530	0.444	10	Pass

Channel Closing Transmission Time

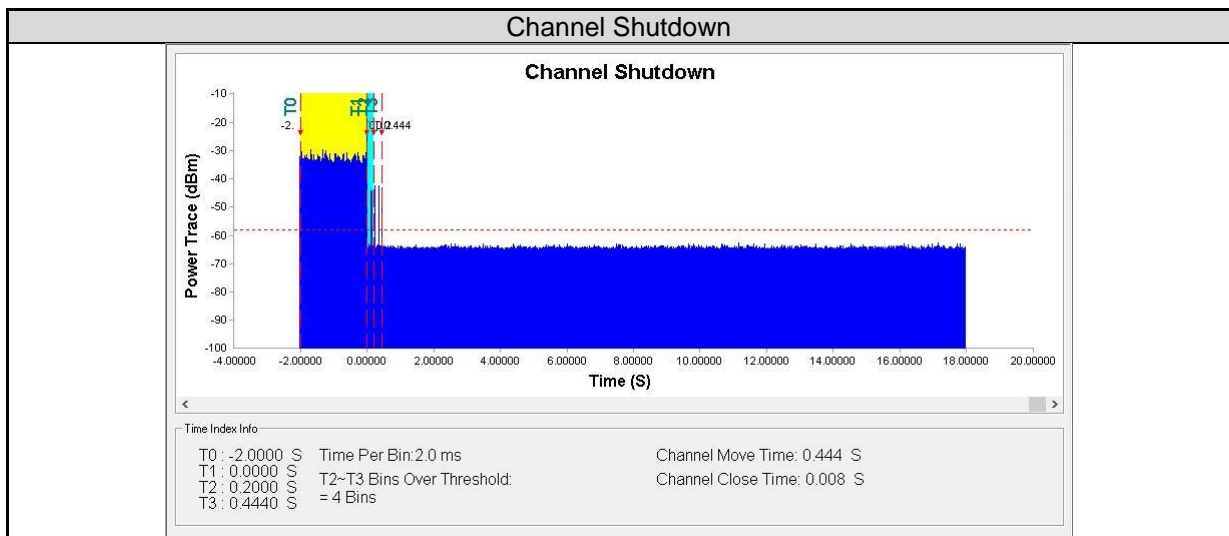
Channel (MHz)	Channel Closing Transmission Time (s)	Limit (ms)	Result
5530	0.008	60	Pass

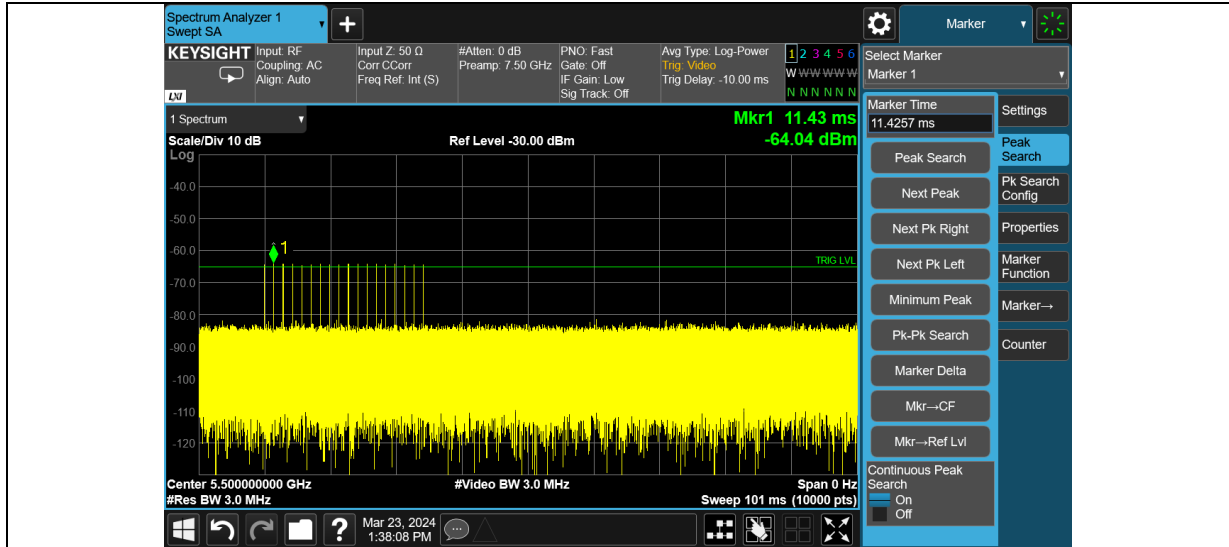

Radar Level

5.2 Mains Emission

5.2.1 Mains Conducted Emission

Limit

Mains Conducted emissions as defined in §15.207 must comply with the mains conducted emission limits.

Kind of Test Site Shielded room

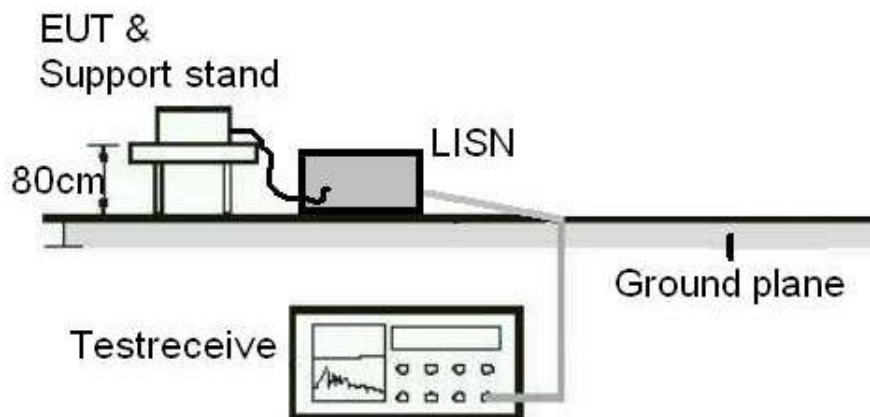
Test Setup

Test Instruments

Kind of Equipment	Manufacturer	Type	S/N	Calibration Date	Calibration Due Date
Two-Line V-Network	Rohde & Schwarz	ENV216	101938	2023/10/23	2024/10/21
EMI Test Receiver	R&S	ESCI	100797	2023/7/21	2024/7/19

Prüfbericht - Nr.: **CN24YOHU 001**
Test Report No.

Seite 38 von 38
Page 38 of 38

Test Procedures

- a. The EUT was placed 0.4 meters from the conducting wall of the shielded room with EUT being connected to the power mains through a line impedance stabilization network (LISN). Other support units were connected to the power mains through another LISN. The two LISNs provide 50 ohm/50 uH of coupling impedance for the measuring instrument.
- b. Both lines of the power mains connected to the EUT were checked for maximum conducted interference.
- c. The frequency range from 150 kHz to 30 MHz was searched. Emission levels under (Limit – 20 dB) was not recorded.

Note: The resolution bandwidth and video bandwidth of test receiver is 9 kHz for quasi-peak detection (QP) and average detection (AV) at frequency 0.15 MHz – 30 MHz.

Test Results

Please refer to Appendix B.

Appendix A: Test Results of Conducted Test

Test Result of 26 dB Bandwidth

802.11a

Band	Channel	Frequency (MHz)	26 dB Bandwidth (MHz)
U-NII-2A	52	5260	26.37
	60	5300	33.21
	64	5320	31.13
U-NII-2C	100	5500	36.32
	116	5580	37.32
	140	5700	37.64

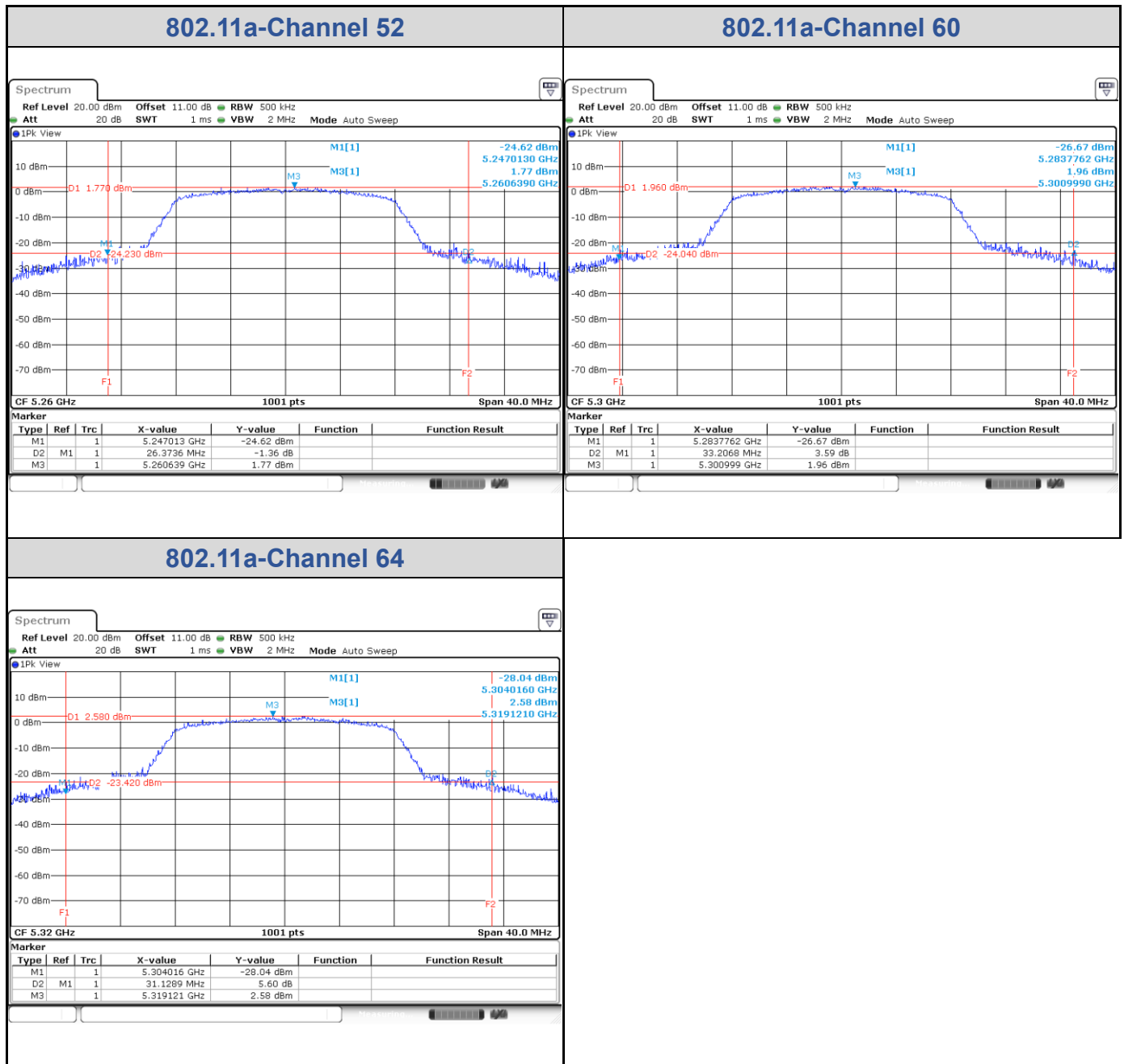

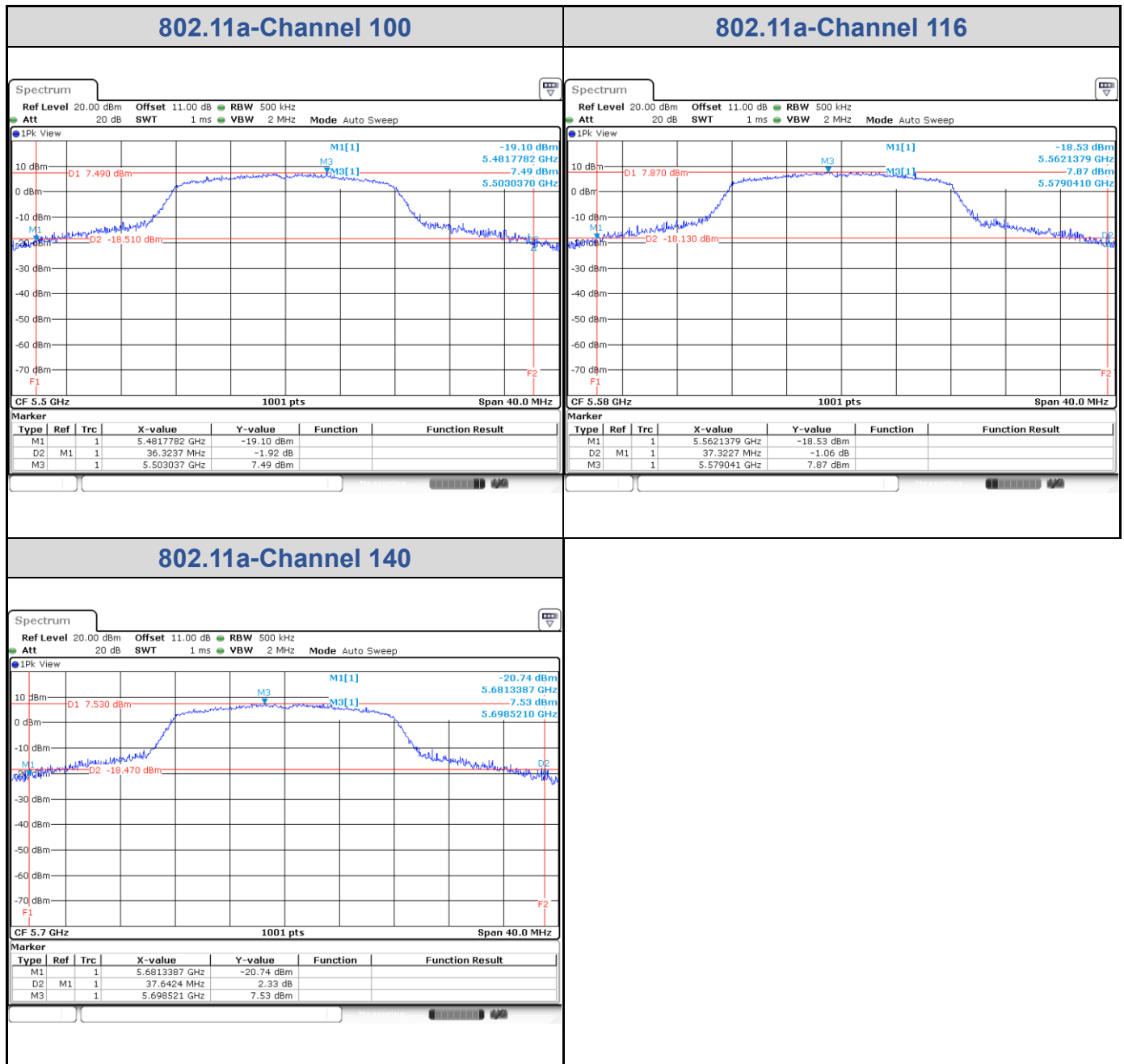

802.11ac VHT20

Band	Channel	Frequency (MHz)	26 dB Bandwidth (MHz)
U-NII-2A	52	5260	26.77
	60	5300	30.25
	64	5320	27.93
U-NII-2C	100	5500	36.16
	116	5580	36.88
	140	5700	35.36

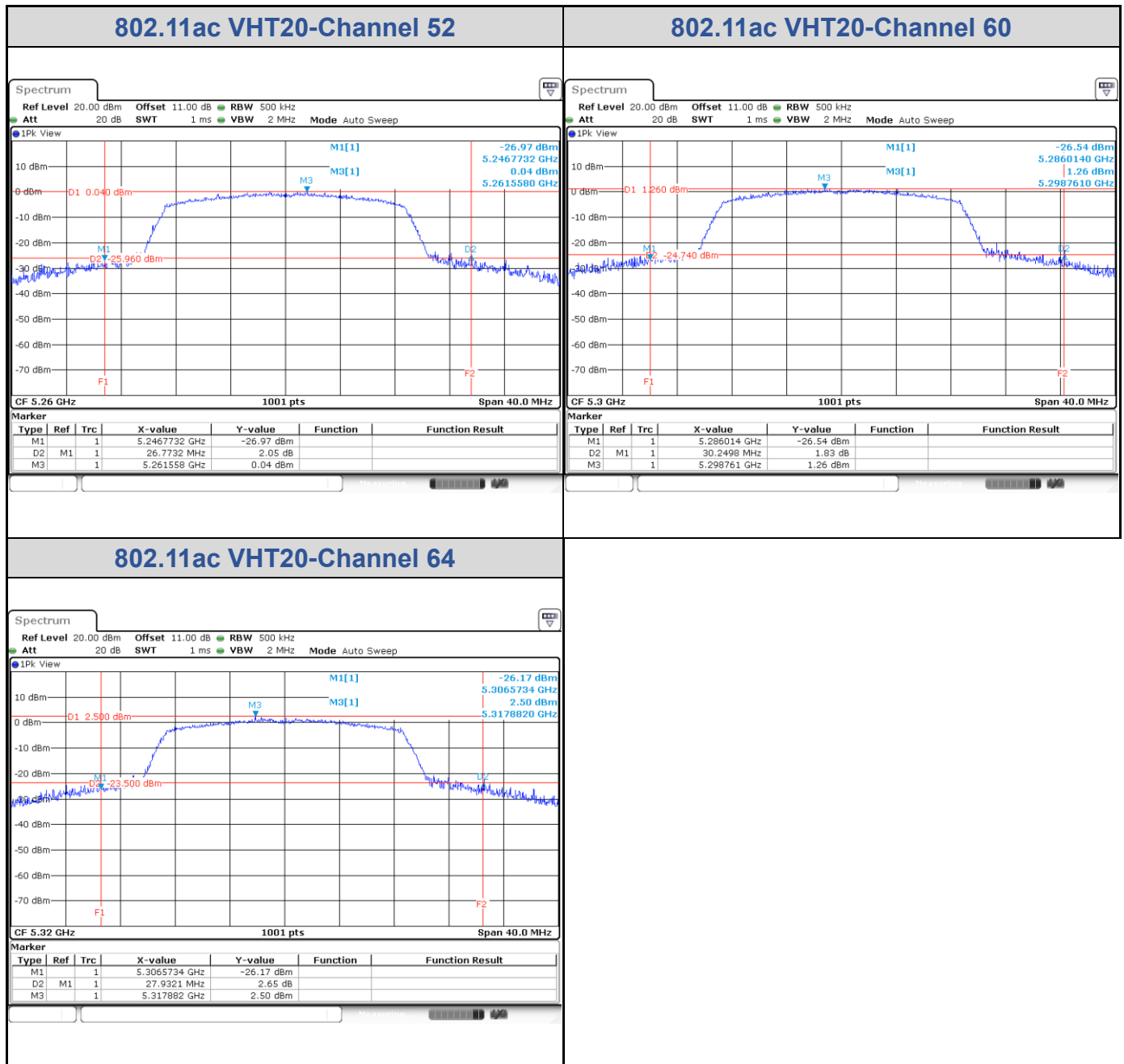

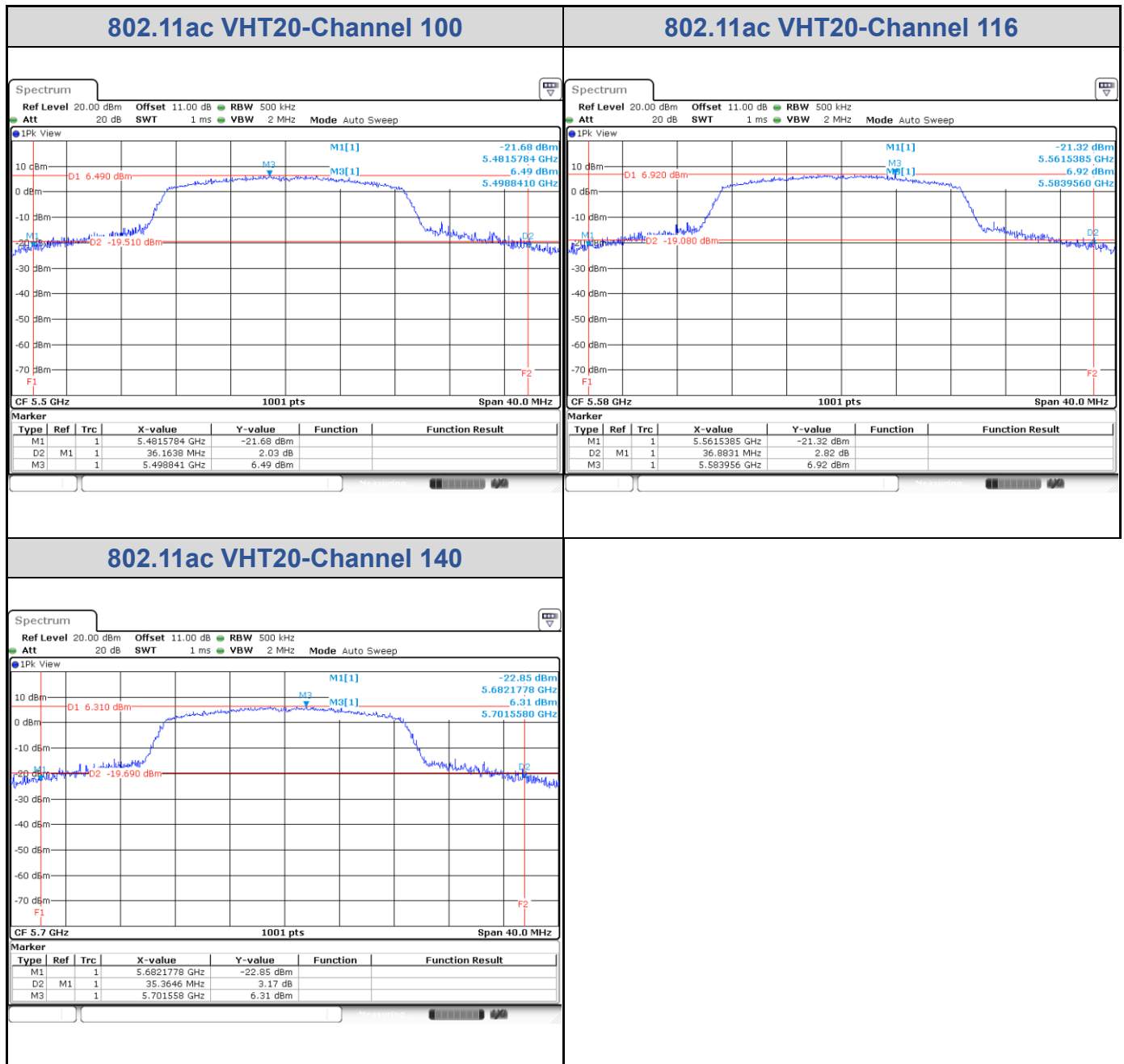

802.11ac VHT40

Band	Channel	Frequency (MHz)	26 dB Bandwidth (MHz)
U-NII-2A	54	5270	72.01
	62	5310	52.35
U-NII-2C	102	5510	45.55
	110	5500	75.76
	134	5670	74.65

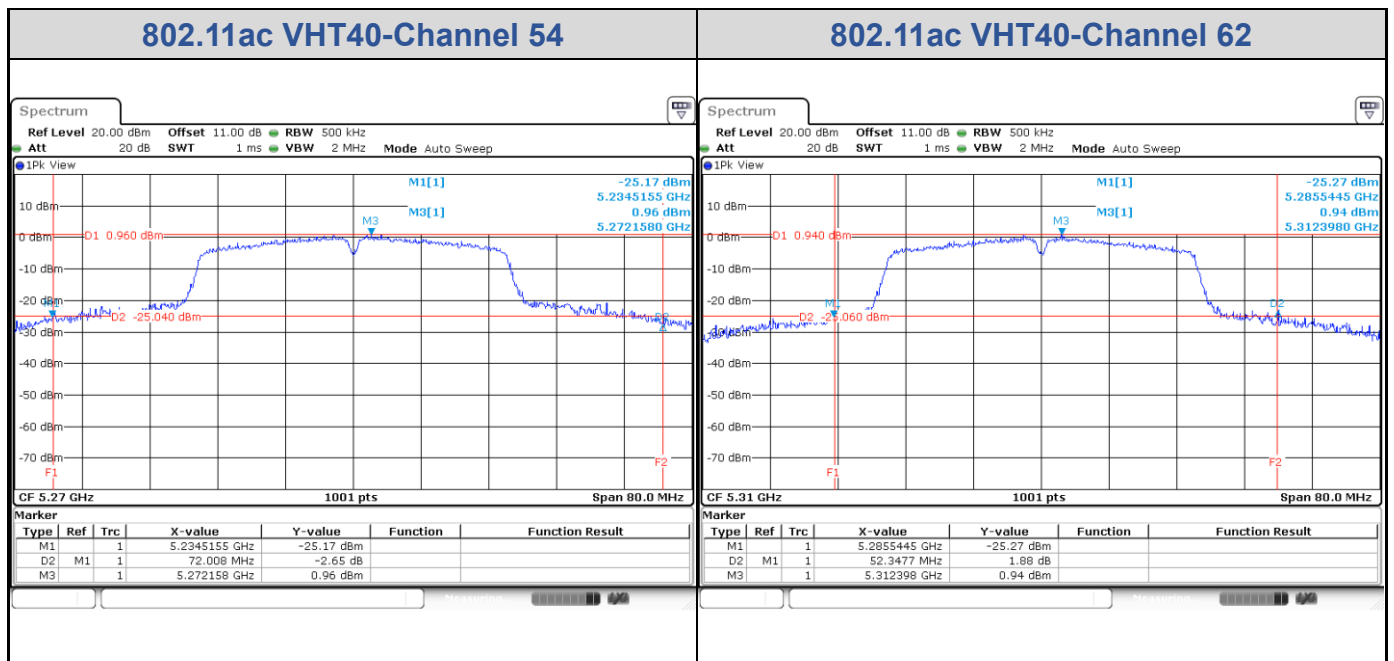

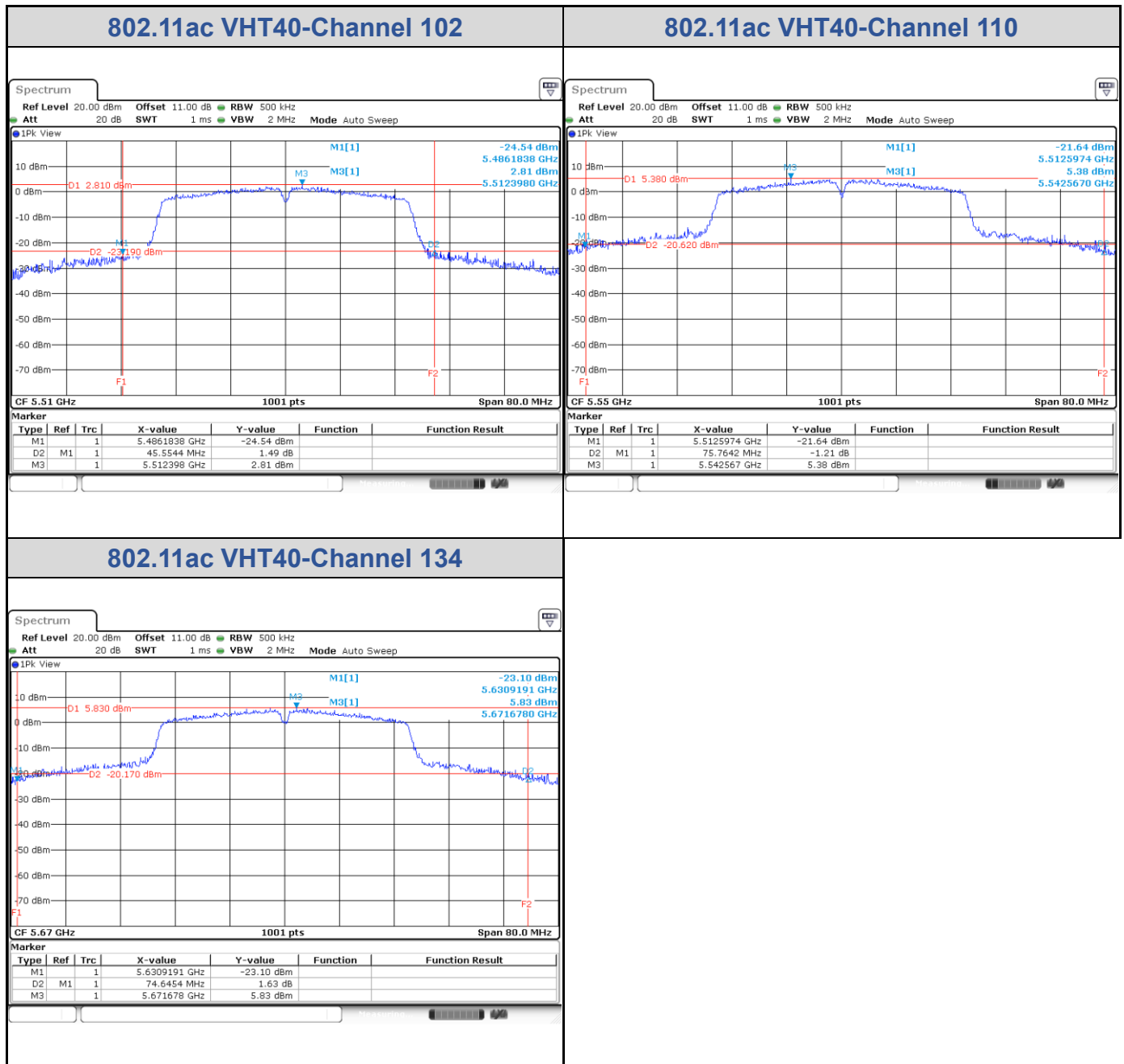

802.11ac VHT80

Band	Channel	Frequency (MHz)	26 dB Bandwidth (MHz)
U-NII-2A	58	5290	119.40
U-NII-2C	106	5530	98.46

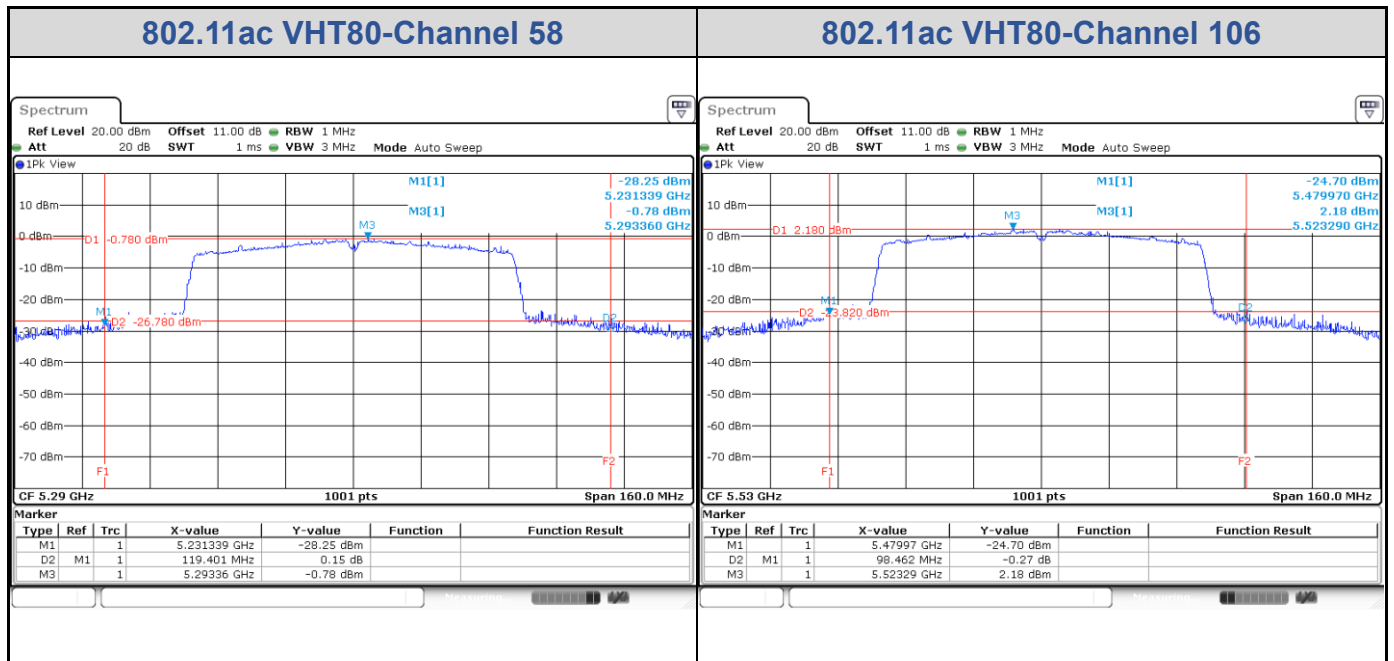

Test Result of 99% Occupied Bandwidth

802.11a

Band	Channel	Frequency (MHz)	99% Bandwidth (MHz)
U-NII-2A	52	5260	17.42
	60	5300	17.66
	64	5320	17.62
U-NII-2C	100	5500	19.18
	116	5580	19.14
	140	5700	18.50

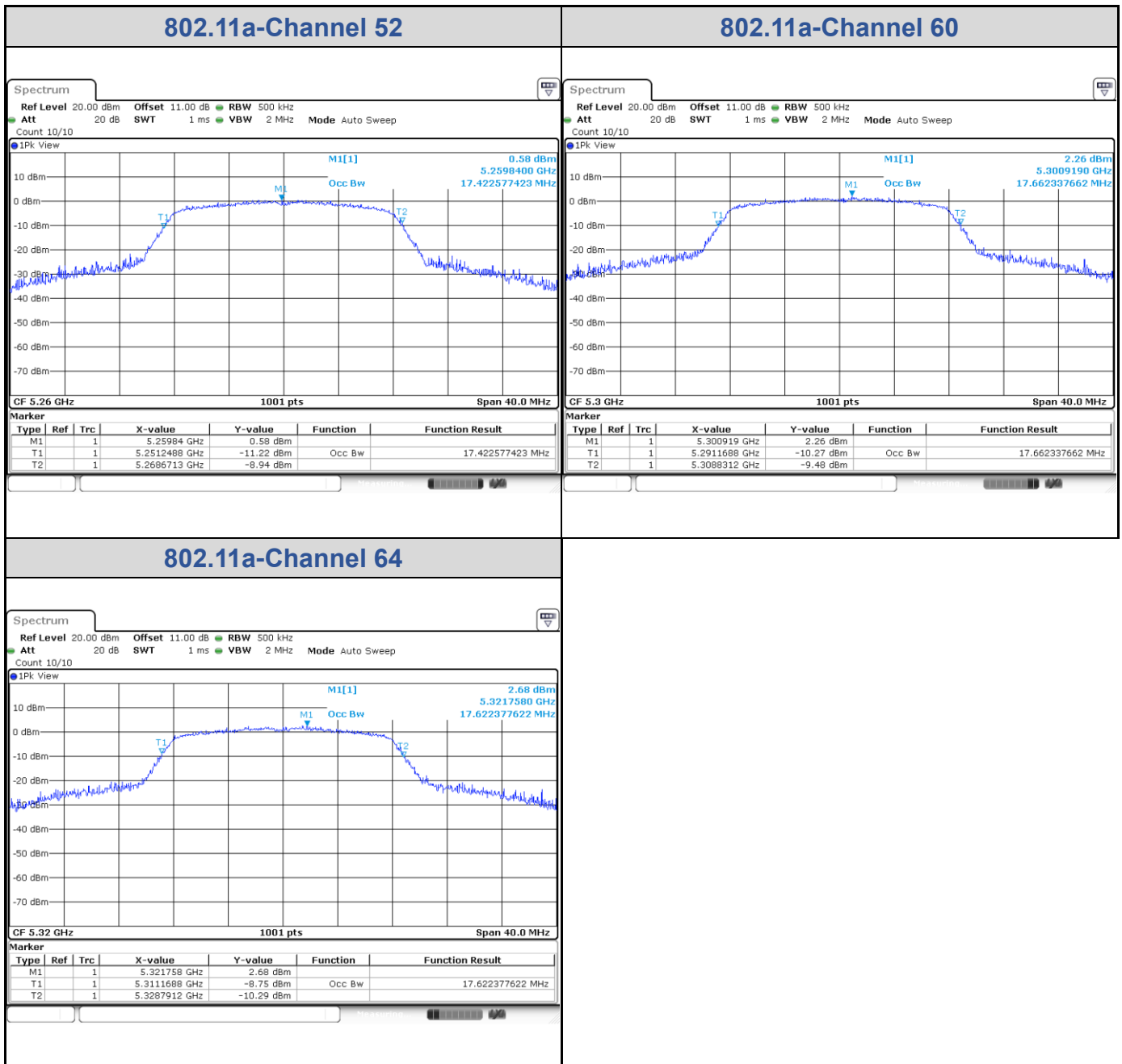

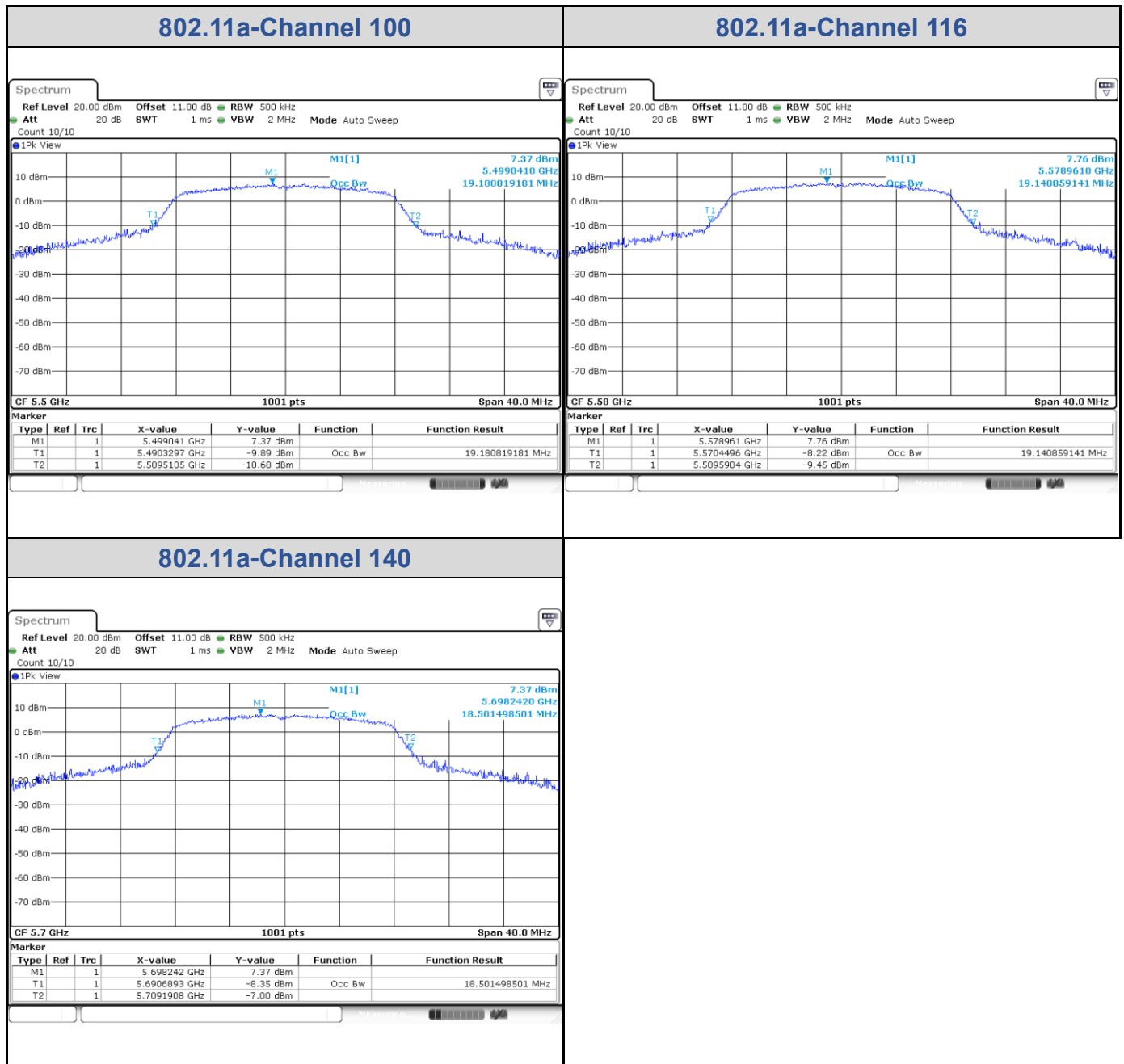

802.11ac VHT20

Band	Channel	Frequency (MHz)	99% Bandwidth (MHz)
U-NII-2A	52	5260	18.22
	60	5300	18.34
	64	5320	18.26
U-NII-2C	100	5500	18.66
	116	5580	18.74
	140	5700	18.54

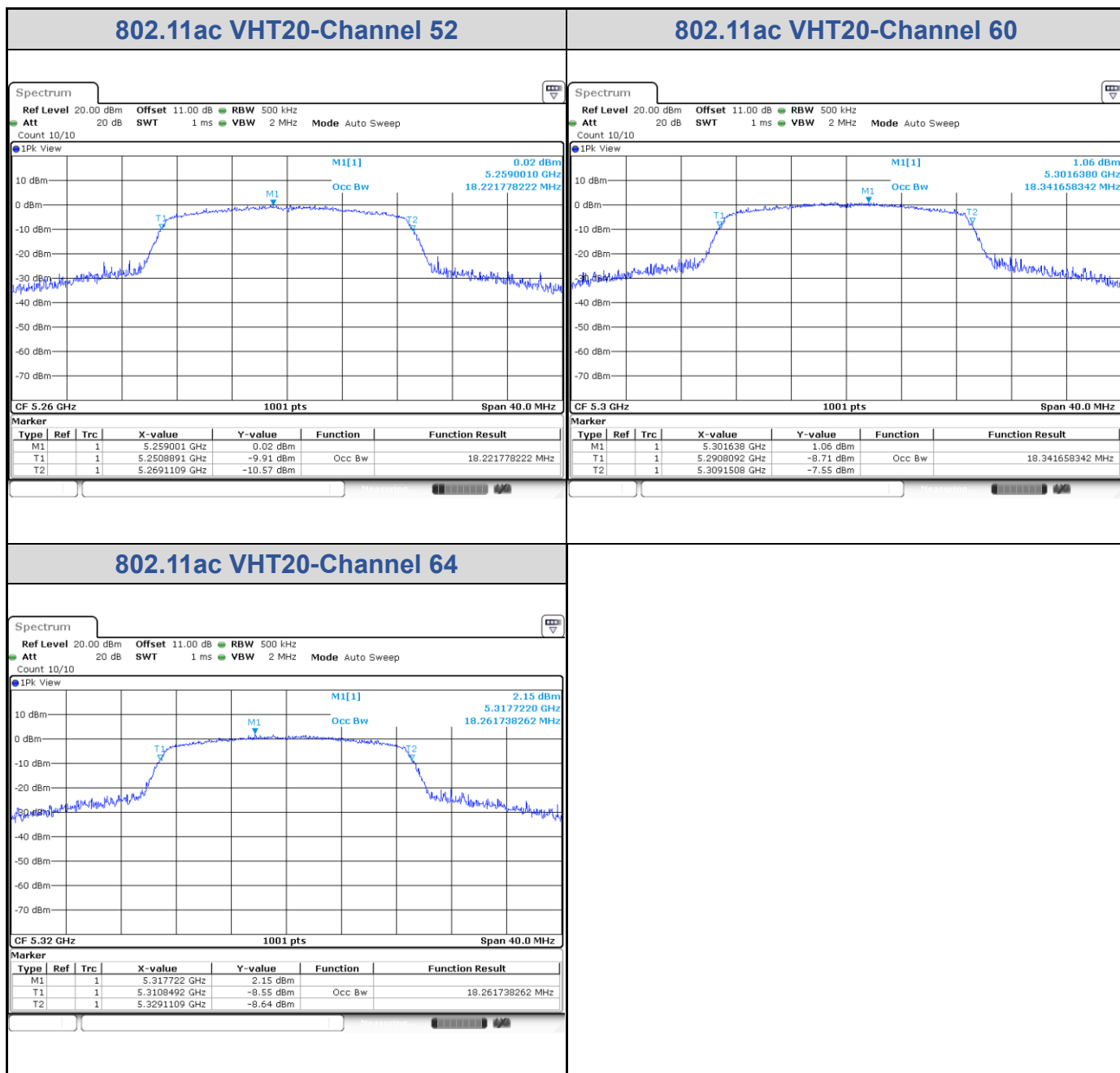

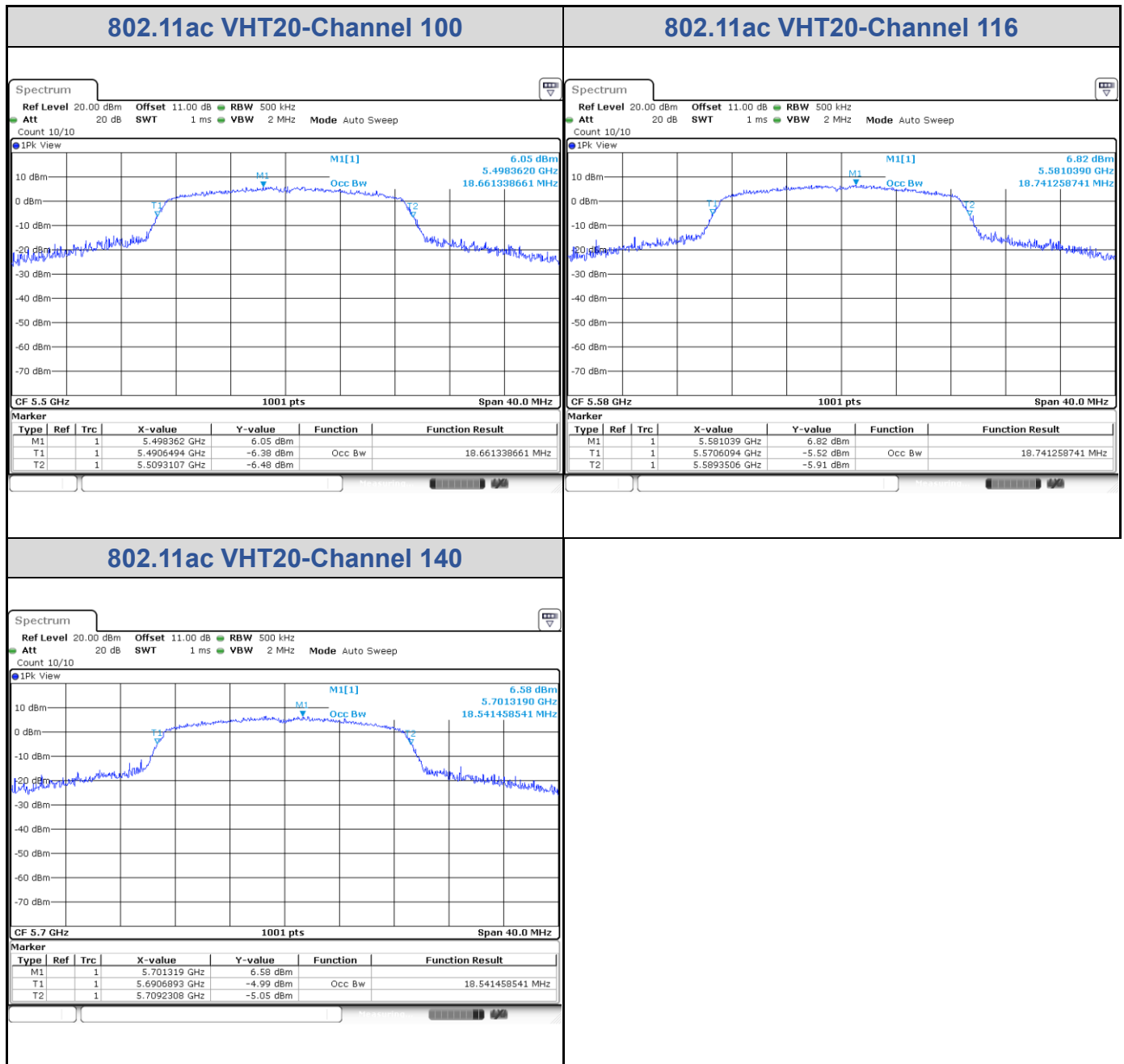

802.11ac VHT40

Band	Channel	Frequency (MHz)	99% Bandwidth (MHz)
U-NII-2A	54	5270	37.32
	62	5310	36.52
U-NII-2C	102	5510	36.28
	110	5550	37.48
	134	5670	37.72

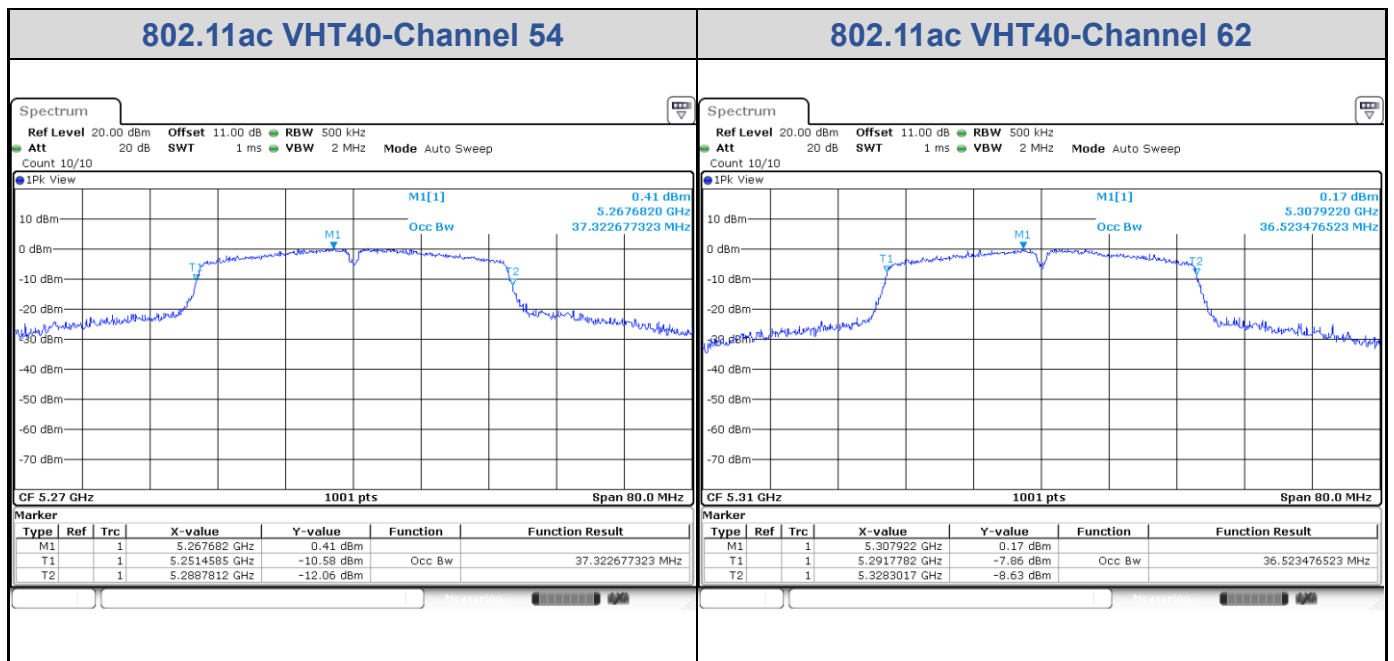

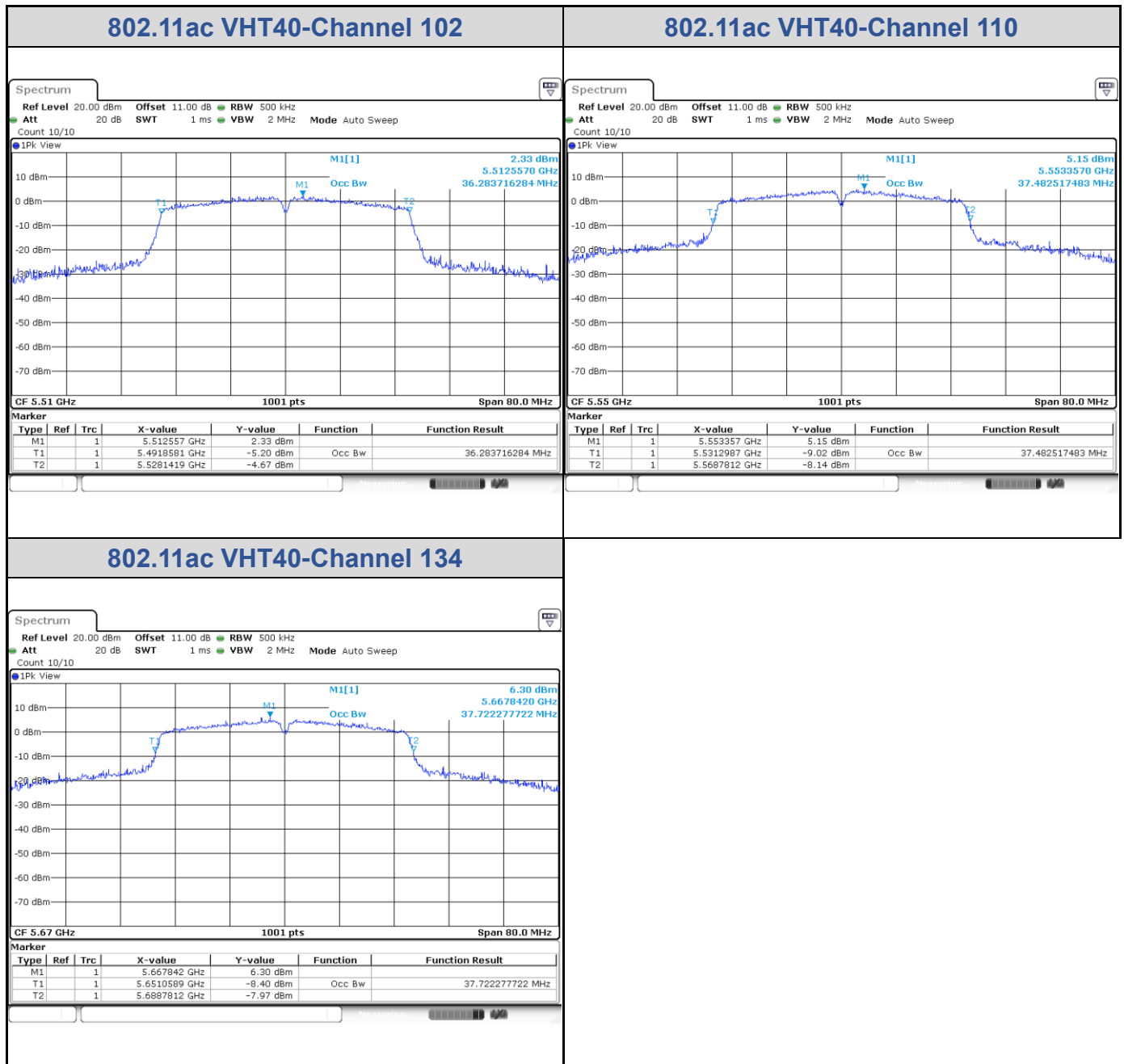

802.11ac VHT80

Band	Channel	Frequency (MHz)	99% Bandwidth (MHz)
U-NII-2A	58	5290	75.60
U-NII-2C	106	5530	75.44

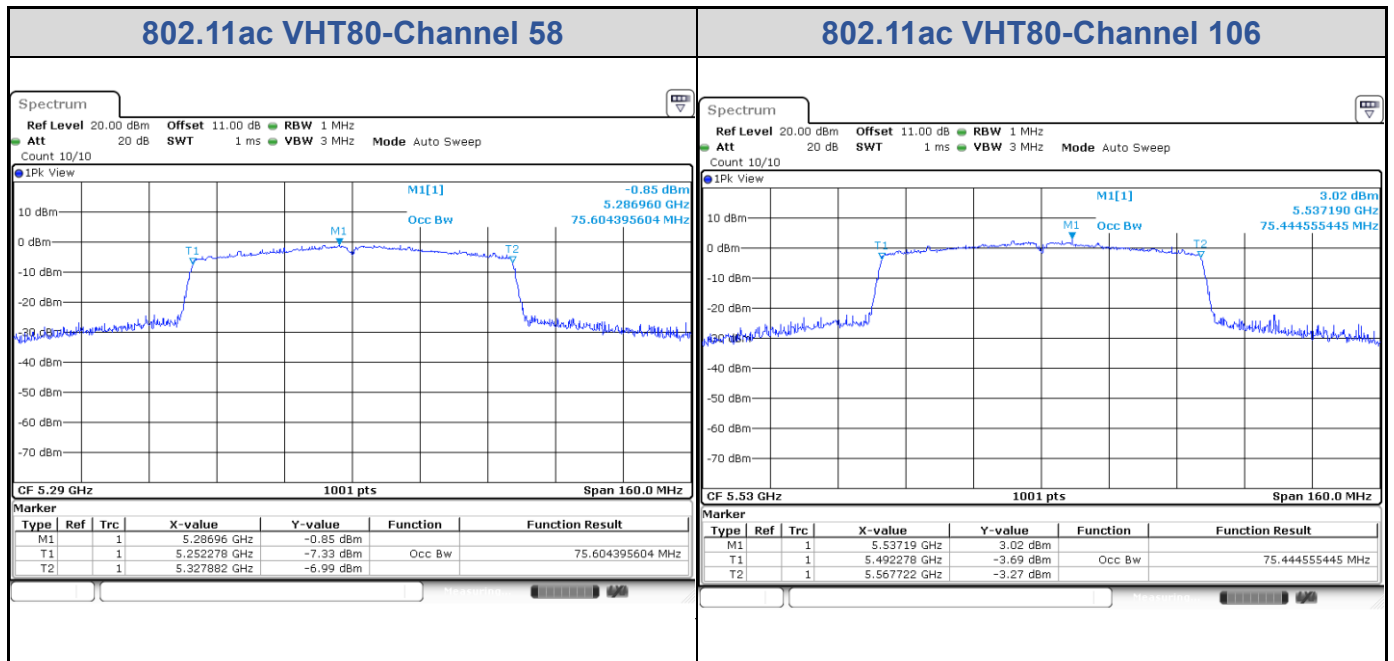

Test Result of Power Spectral Density

802.11a

Band	Channel	Frequency (MHz)	PSD without Duty Factor (dBm/MHz)	Total PSD with Duty Factor (dBm/MHz)	Maximum Limit (dBm/MHz)	Pass / Fail
U-NII-2A	52	5260	-4.05	-3.90	11.00	Pass
	60	5300	-3.07	-2.92	11.00	Pass
	64	5320	-2.46	-2.31	11.00	Pass
U-NII-2C	100	5500	2.74	2.89	11.00	Pass
	116	5580	2.95	3.10	11.00	Pass
	140	5700	2.69	2.84	11.00	Pass

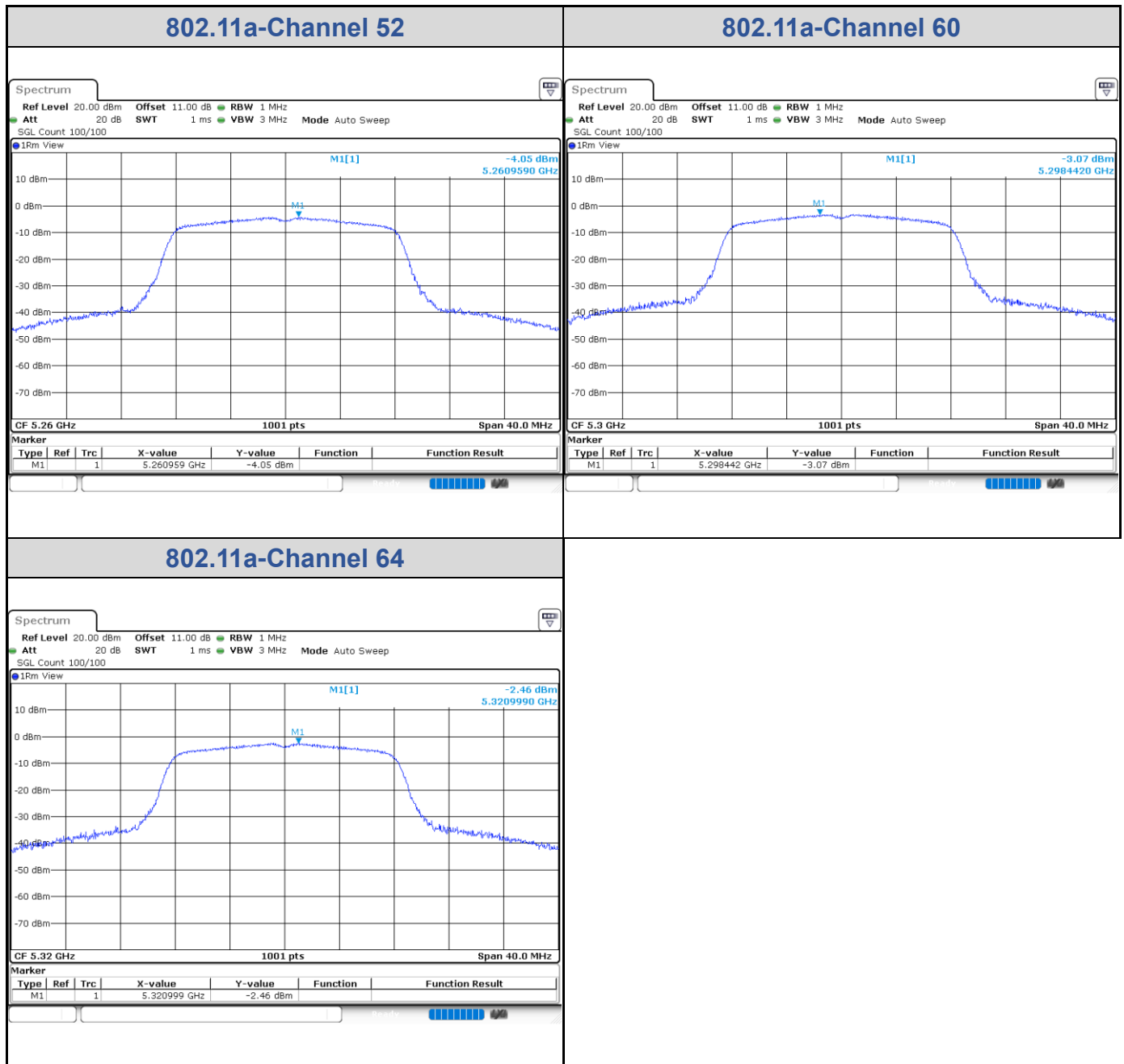

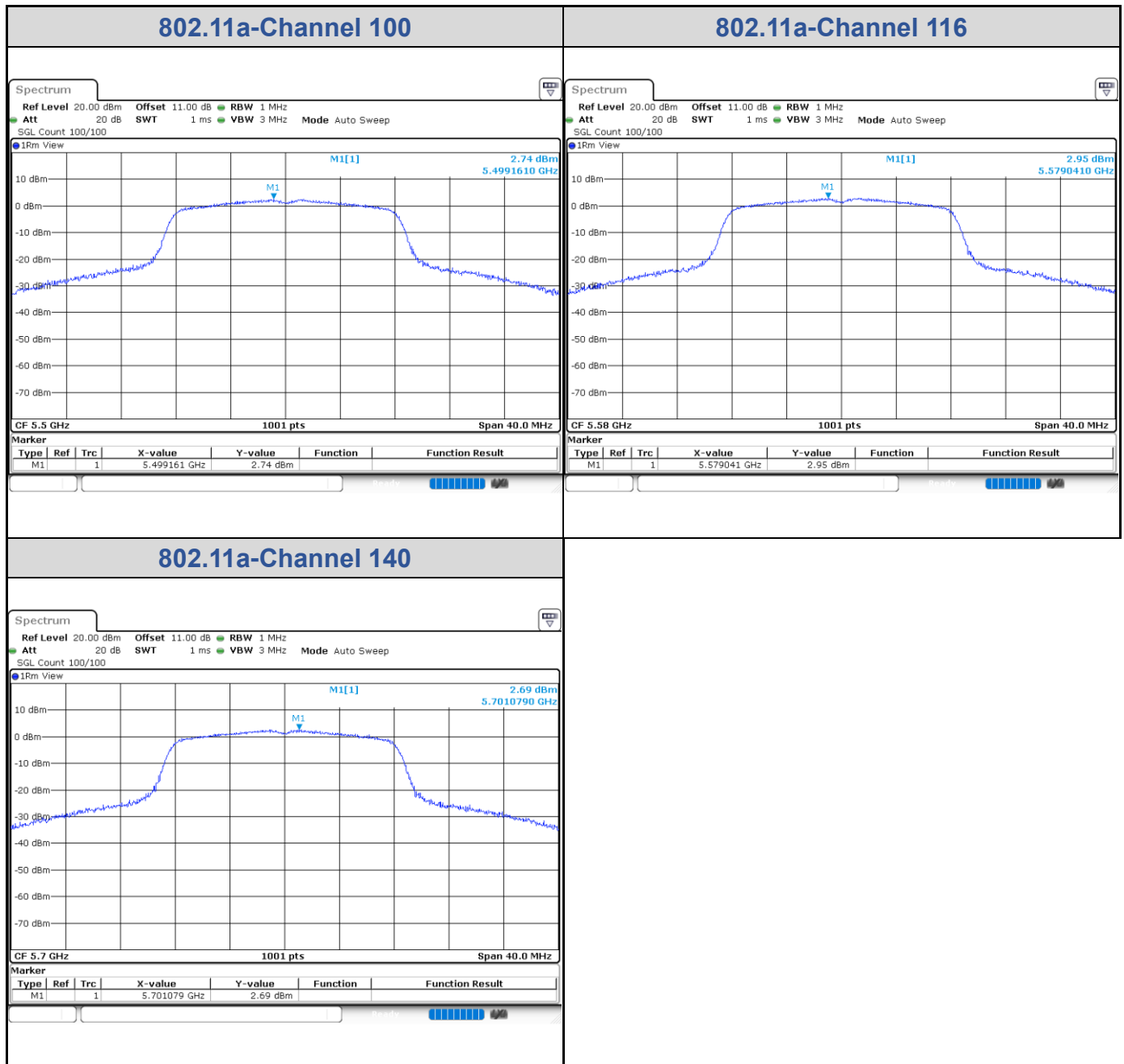

802.11ac VHT20

Band	Channel	Frequency (MHz)	PSD without Duty Factor (dBm/MHz)	Total PSD with Duty Factor (dBm/MHz)	Maximum Limit (dBm/MHz)	Pass / Fail
U-NII-2A	52	5260	-4.98	-4.83	11.00	Pass
	60	5300	-3.87	-3.72	11.00	Pass
	64	5320	-3.06	-2.91	11.00	Pass
U-NII-2C	100	5500	2.30	2.45	11.00	Pass
	116	5580	3.09	3.24	11.00	Pass
	140	5700	1.66	1.81	11.00	Pass

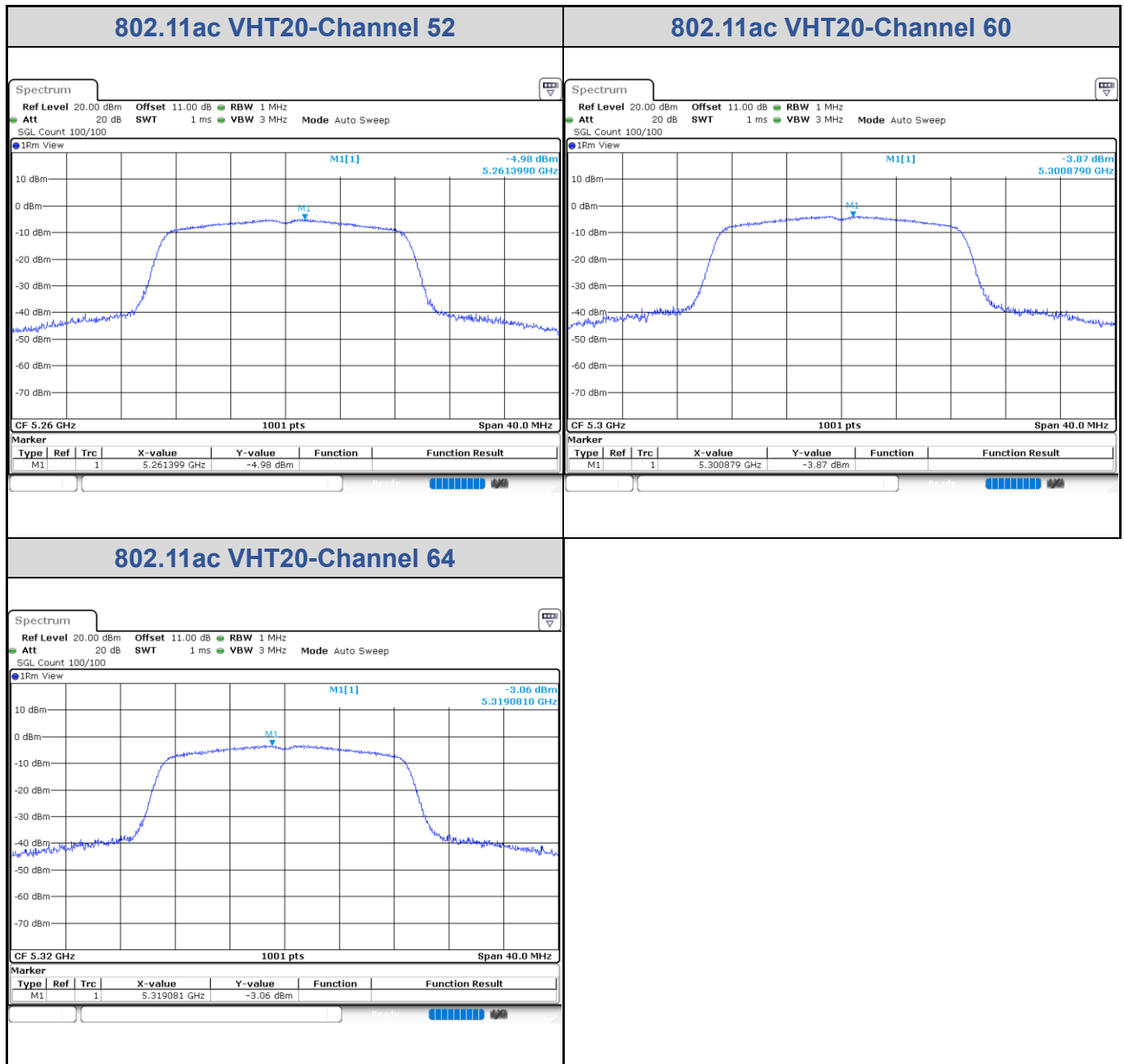

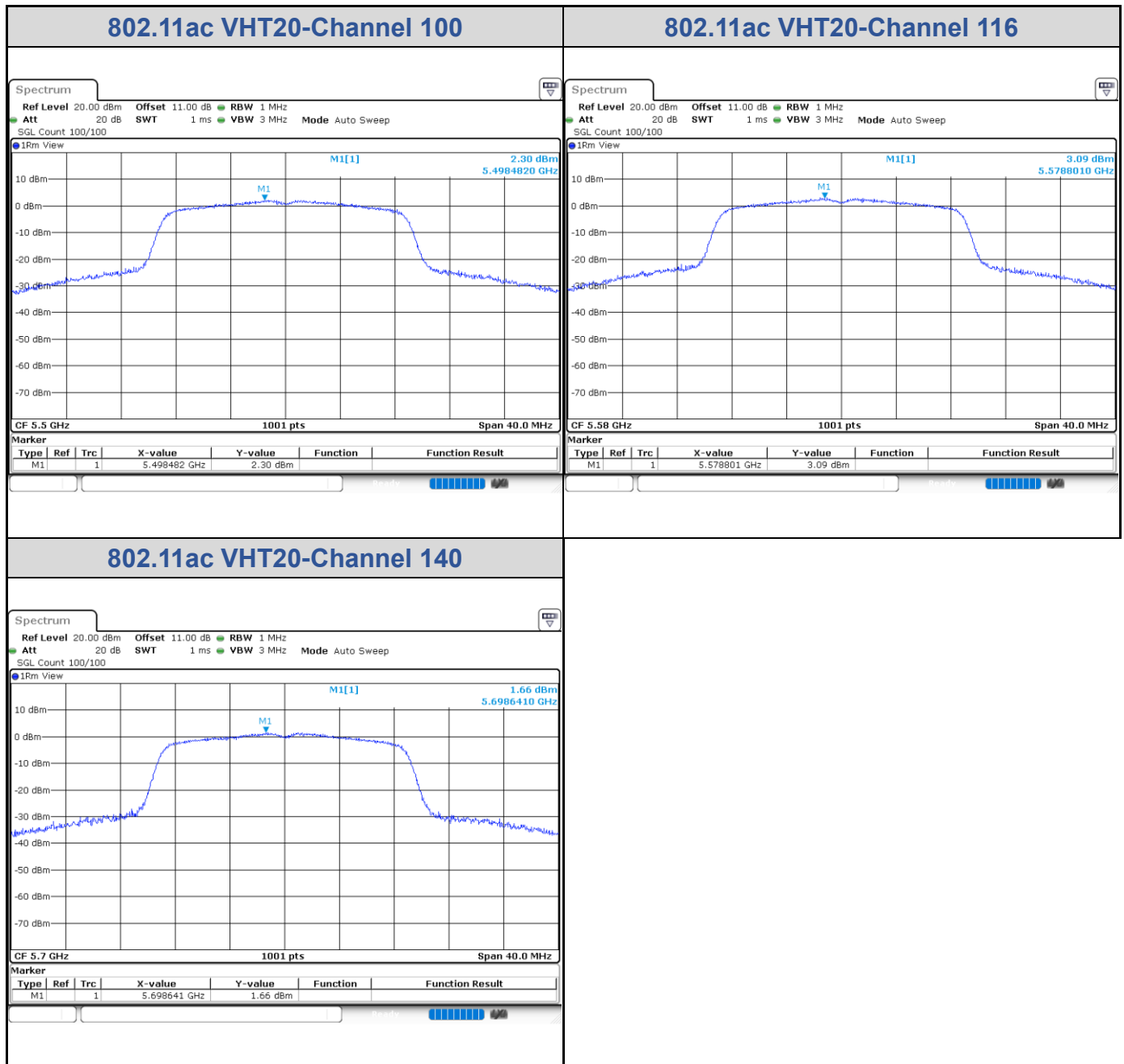

802.11ac VHT40

Band	Channel	Frequency (MHz)	PSD without Duty Factor (dBm/MHz)	Total PSD with Duty Factor (dBm/MHz)	Maximum Limit (dBm/MHz)	Pass / Fail
U-NII-2A	54	5270	-2.95	-2.65	11.00	Pass
	62	5310	-4.81	-4.51	11.00	Pass
U-NII-2C	102	5510	-2.95	-2.65	11.00	Pass
	110	5550	2.24	2.54	11.00	Pass
	134	5670	0.86	1.16	11.00	Pass

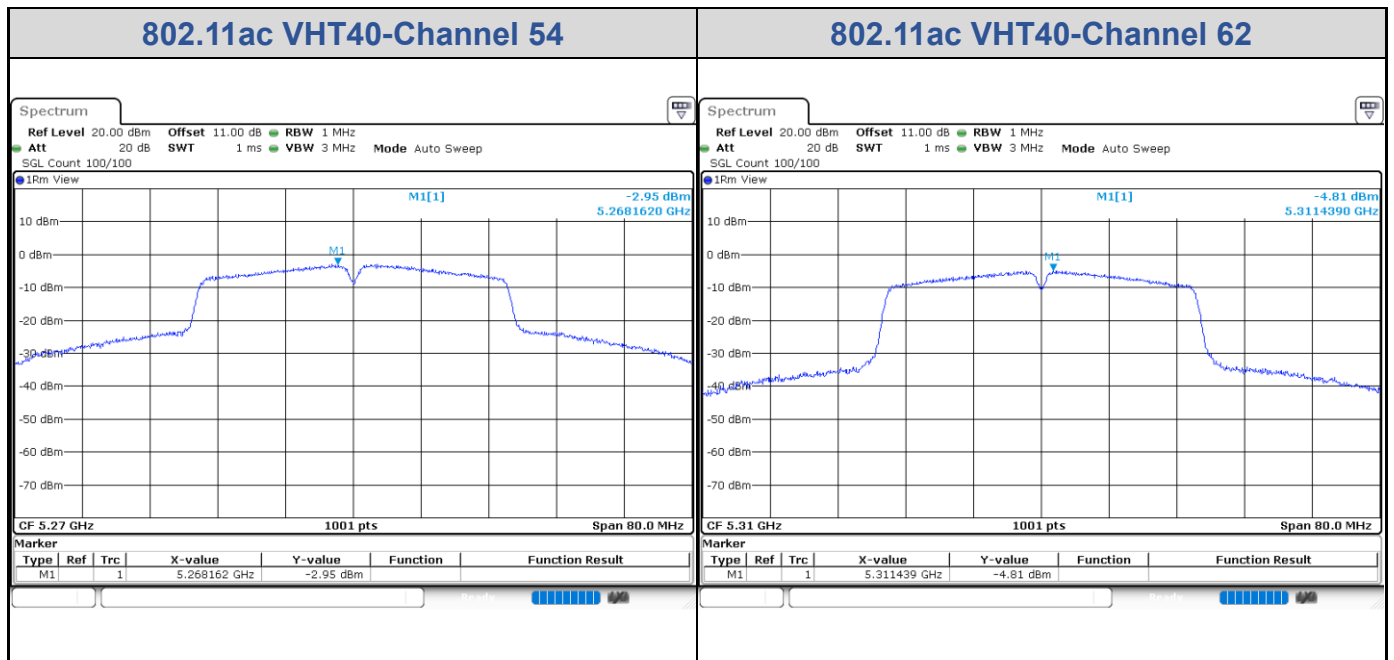

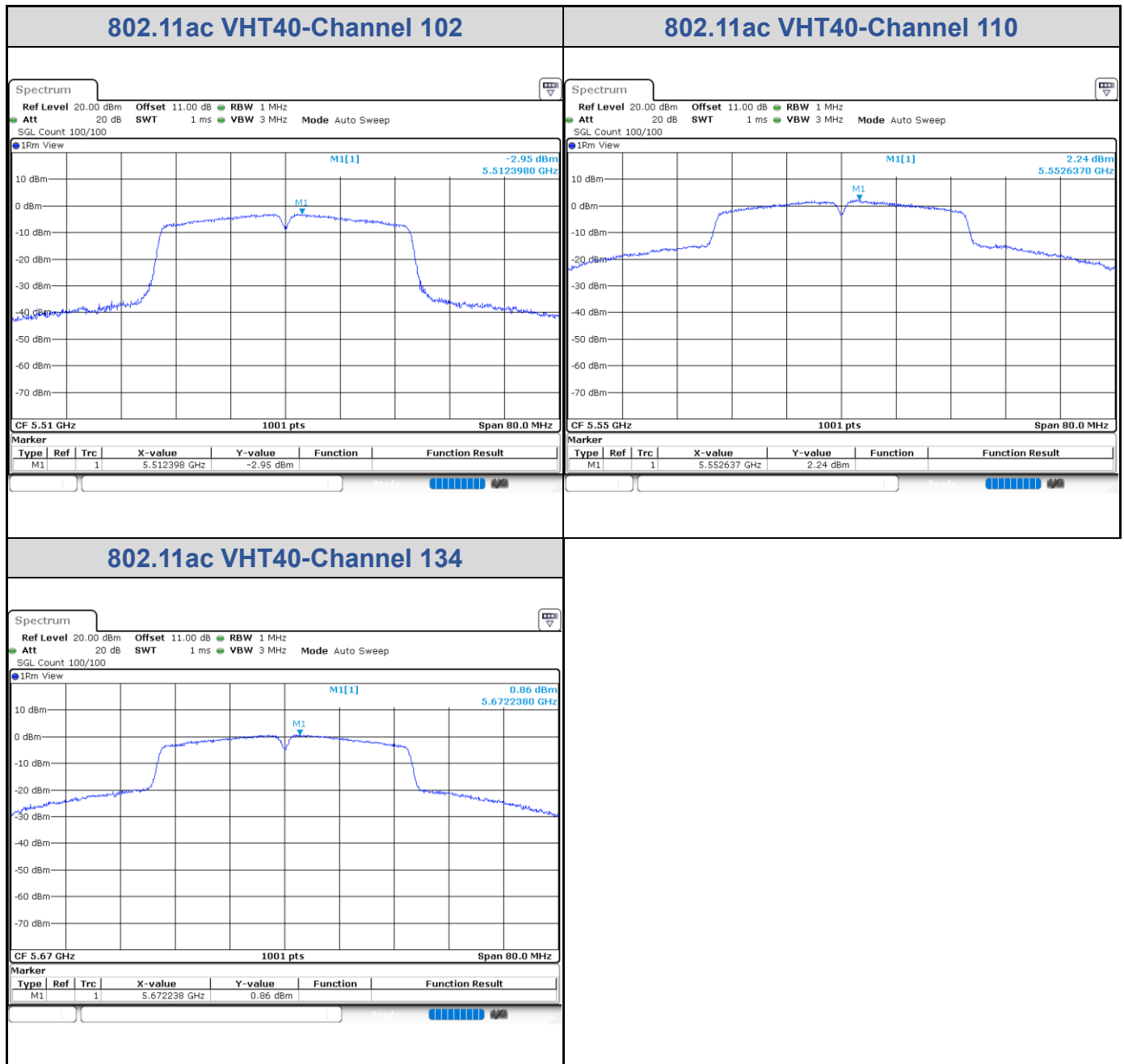

802.11ac VHT80

Band	Channel	Frequency (MHz)	PSD without Duty Factor (dBm/MHz)	Total PSD with Duty Factor (dBm/MHz)	Maximum Limit (dBm/MHz)	Pass / Fail
U-NII-2A	58	5290	-9.37	-8.81	11.00	Pass
U-NII-2C	106	5530	-6.47	-5.91	11.00	Pass

