



FCC TEST REPORT

Prepared for :

Proscend Communications Inc.

2F, No. 36, Industry E. Rd. IV, Hsinchu Science Park, Hsinchu, Taiwan, R.O.C.

FCC ID: 2AUAE-M3300001

Product: Industrial 4G LTE Cellular Router

Trade Name: Proscend

Model Name: M330-W, MXXX-XXXXX-XX (Where "X" can be used as "A-Z", or "0-9", or "-", or blank for hardware/software changes/applications or marketing purpose only)

Date of Test: Aug. 06, 2019~ Aug. 13, 2019

Date of Report: Aug. 13, 2019

Report Number: HK1907301843-7E

Prepared By :

Shenzhen HUAKE Testing Technology Co., Ltd.

1F, B2 Building, Junfeng Zhongcheng Zhizao Innovation Park, Heping

Community, Fuhai Street, Bao'an District, Shenzhen, China

TEL: +86-755-2302 9901 FAX: +86-755-2302 9901

E-mail: service@cer-mark.com <http://www.cer-mark.com>



TEST REPORT VERIFICATION

Applicant : Proscend Communications Inc.
 Address : 2F, No. 36, Industry E. Rd. IV, Hsinchu Science Park, Hsinchu, Taiwan, R.O.C.
 Manufacturer : Proscend Communications Inc.
 Address : 2F, No. 36, Industry E. Rd. IV, Hsinchu Science Park, Hsinchu, Taiwan, R.O.C.
 EUT Description : Industrial 4G LTE Cellular Router
 (A) Model No. : M330-W
 (B) Serial No. : MXXX-XXXXX-XX (Where "X" can be used as "A-Z", or "0-9", or "-", or blank for hardware/software changes/applications or marketing purpose only)
 (C) Power Supply : DC 8-48V

Standards FCC Part 15 Subpart B
 ANSI C63.4:2014

This device described above has been tested by HUAKE, and the test results show that the equipment under test (EUT) is in compliance with Part 15 of FCC Rules. And it is applicable only to the tested sample identified in the report.

This report shall not be reproduced except in full, without the written approval of HUAKE, this document may be altered or revised by HUAKE, personal only, and shall be noted in the revision of the document.

Date of Test.....

Date (s) of performance of tests..... Aug. 06, 2019~ Aug. 13, 2019

Date of Issue Aug. 13, 2019

Test Result **Pass**

Testing Engineer : Gary Qian
 (Gary Qian)

Technical Manager : Eden Hu
 (Eden Hu)

Authorized Signatory : Jason Zhou
 (Jason Zhou)



1 . TEST SUMMARY	4
1.1 TEST FACILITY	5
1.2 MEASUREMENT UNCERTAINTY	5
2 . GENERAL INFORMATION	6
2.1 GENERAL DESCRIPTION OF EUT	6
2.2 DESCRIPTION OF TEST MODES	7
2.3 DESCRIPTION OF TEST SETUP	8
2.4 DESCRIPTION TEST PERIPHERAL AND EUT PERIPHERAL	8
2.5 MEASUREMENT INSTRUMENTS LIST	9
3 . EMC EMISSION TEST	10
3.1 CONDUCTED EMISSION MEASUREMENT	10
3.1.1 POWER LINE CONDUCTED EMISSION	10
3.1.2 TEST PROCEDURE	11
3.1.3 TEST SETUP	11
3.1.4 EUT OPERATING CONDITIONS	11
3.1.5 TEST RESULTS	12
3.2 RADIATED EMISSION MEASUREMENT	13
3.2.1 LIMITS OF RADIATED EMISSION MEASUREMENT	13
3.2.2 TEST PROCEDURE	13
3.2.3 TEST SETUP	14
3.2.4 EUT OPERATING CONDITIONS	14
3.2.5 TEST RESULTS	15
3.2.6 TEST RESULTS(Above 1GHz)	17
4 . EUT TEST PHOTO	18
5. PHOTOS OF THE EUT	19



1. TEST SUMMARY

Test procedures according to the technical standards:

EMC Emission				
Standard	Test Item	Limit	Judgment	Remark
FCC Part 15 Subpart B ANSI C63.4:2014	Conducted Emission	Class B	PASS	
	Radiated Emission	Class B	PASS	

NOTE:

- (1) 'N/A' denotes test is not applicable in this Test Report
- (2) For client's request and manual description, the test will not be executed.



1.1 TEST FACILITY

Test Firm : Shenzhen HUAKE Testing Technology Co., Ltd.

Address : 1F, B2 Building, Junfeng Zhongcheng Zhizao Innovation Park,
Fuhai Street, Bao'an District, Shenzhen City, China

Designation Number : CN1229

Test Firm Registration Number:616276

IC Registration No.: 21210

The 3m alternate test site of Shenzhen HUAKE Testing Technology Co., Ltd. EMC Laboratory has been registered by Certification and Engineer Bureau of Industry Canada for the performance of with Registration No.: 21210 on May 24, 2016.

1.2 MEASUREMENT UNCERTAINTY

The reported uncertainty of measurement $y \pm U$ · where expanded uncertainty U is based on a standard uncertainty multiplied by a coverage factor of $k=2$ · providing a level of confidence of approximately **95** %.

Measurement Uncertainty

Conducted Emission Expanded Uncertainty	=	2.23dB, k=2
Radiated emission expanded uncertainty(9kHz-30MHz)	=	3.08dB, k=2
Radiated emission expanded uncertainty(30MHz-1000MHz)	=	4.42dB, k=2
Radiated emission expanded uncertainty(Above 1GHz)	=	4.06dB, k=2



2. GENERAL INFORMATION

2.1 GENERAL DESCRIPTION OF EUT

Equipment	Industrial 4G LTE Cellular Router	
Model Name	M330-W	
Serial No	MXXX-XXXXX-XX (Where "X" can be used as "A-Z", or "0-9", or "-", or blank for hardware/software changes/applications or marketing purpose only)	
Model Difference	All model's the function, software and electric circuit are the same, only with a product outward and model named different. Test sample model: M330-W	
Product Description	The EUT is a Industrial 4G LTE Cellular Router	
	Operating frequency:	N/A
	Connecting I/O port:	N/A
	Based on the application, features, or specification exhibited in User's Manual, the EUT is considered as an ITE/Computing Device. More details of EUT technical specification, please refer to the User's Manual.	
Power Source	DC Voltage	
Power Rating	DC 8-48V	



2.2 DESCRIPTION OF TEST MODES

To investigate the maximum EMI emission characteristics generated from EUT, the test system was pre-scanning tested based on the consideration of following EUT operation mode or test configuration mode which possibly have effect on EMI emission level. Each of these EUT operation mode(s) or test configuration mode(s) mentioned above was evaluated respectively.

Pretest Mode	Description
Mode 1	Running

For Conducted Test	
Final Test Mode	Description
Mode 1	Running

For Radiated Test	
Final Test Mode	Description
Mode 1	Running



2.3 DESCRIPTION OF TEST SETUP



- PC information
 Model: TP00067A
 Input: DC20V, 2.25/3.25A
 Output: 5VDC, 1A

2.4 DESCRIPTION TEST PERIPHERAL AND EUT PERIPHERAL

The EUT has been tested as an independent unit together with other necessary accessories or support units. The following support units or accessories were used to form a representative test configuration during the tests.

Item	Equipment	Mfr/Brand	Model/Type No.	Series No.	Note
E-1	Industrial 4G LTE Cellular Router	Proscend	M330-W	N/A	EUT
E-2	PC	N/A	TP00067A	N/A	N/A



2.5 MEASUREMENT INSTRUMENTS LIST

Item	Equipment	Manufacturer	Model No.	Serial No.	Last Cal.	Cal. Interval
1.	L.I.S.N. Artificial Mains Network	R&S	ENV216	HKE-002	Dec. 27, 2018	1 Year
2.	Receiver	R&S	ESCI 7	HKE-010	Dec. 27, 2018	1 Year
3.	RF automatic control unit	Tonscend	JS0806-2	HKE-060	Dec. 27, 2018	1 Year
4.	Spectrum analyzer	R&S	FSP40	HKE-025	Dec. 27, 2018	1 Year
5.	Spectrum analyzer	Agilent	N9020A	HKE-048	Dec. 27, 2018	1 Year
6.	Preamplifier	Schwarzbeck	BBV 9743	HKE-006	Dec. 27, 2018	1 Year
7.	EMI Test Receiver	Rohde & Schwarz	ESCI 7	HKE-010	Dec. 27, 2018	1 Year
8.	Bilog Broadband Antenna	Schwarzbeck	VULB9163	HKE-012	Dec. 27, 2018	1 Year
9.	Loop Antenna	Schwarzbeck	FMZB 1519 B	HKE-014	Dec. 27, 2018	1 Year
10.	Horn Antenna	Schwarzbeck	9120D	HKE-013	Dec. 27, 2018	1 Year
11.	Pre-amplifier	EMCI	EMC05184 5SE	HKE-015	Dec. 27, 2018	1 Year
12.	Pre-amplifier	Agilent	83051A	HKE-016	Dec. 27, 2018	1 Year
13.	EMI Test Software EZ-EMC	Tonscend	JS1120-B Version	HKE-083	Dec. 27, 2018	N/A
14.	Power Sensor	Agilent	E9300A	HKE-086	Dec. 27, 2018	1 Year
15.	Spectrum analyzer	Agilent	N9020A	HKE-048	Dec. 27, 2018	1 Year
16.	Signal generator	Agilent	N5182A	HKE-029	Dec. 27, 2018	1 Year
17.	Signal Generator	Agilent	83630A	HKE-028	Dec. 27, 2018	1 Year
18.	Shielded room	Shiel Hong	4*3*3	HKE-039	Dec. 27, 2018	3 Year



3. EMC EMISSION TEST

3.1 CONDUCTED EMISSION MEASUREMENT

3.1.1 POWER LINE CONDUCTED EMISSION (Frequency Range 150KHz-30MHz)

FREQUENCY (MHz)	Class A (dBuV)		Class B (dBuV)	
	Quasi-peak	Average	Quasi-peak	Average
0.15 -0.5	79.00	66.00	66 - 56 *	56 - 46 *
0.50 -5.0	73.00	60.00	56.00	46.00
5.0 -30.0	73.00	60.00	60.00	50.00

Note:

- (1) The tighter limit applies at the band edges.
- (2) The limit of " * " marked band means the limitation decreases linearly with the logarithm of the frequency in the range.

The following table is the setting of the receiver

Receiver Parameters	Setting
Attenuation	10 dB
Start Frequency	0.15 MHz
Stop Frequency	30 MHz
IF Bandwidth	9 kHz

3.1.2 TEST PROCEDURE

- a. The EUT was placed 0.4 meters from the horizontal ground plane with EUT being connected to the power mains through a line impedance stabilization network (LISN). All other support equipments powered from additional LISN(s). The LISN provide 50 Ohm/ 50uH of coupling impedance for the measuring instrument.
- b. Interconnecting cables that hang closer than 40 cm to the ground plane shall be folded back and forth in the center forming a bundle 30 to 40 cm long.
- c. I/O cables that are not connected to a peripheral shall be bundled in the center. The end of the cable may be terminated, if required, using the correct terminating impedance. The overall length shall not exceed 1 m.
- d. LISN at least 80 cm from nearest part of EUT chassis.
- e. For the actual test configuration, please refer to the related Item –EUT Test Photos.

3.1.3 TEST SETUP

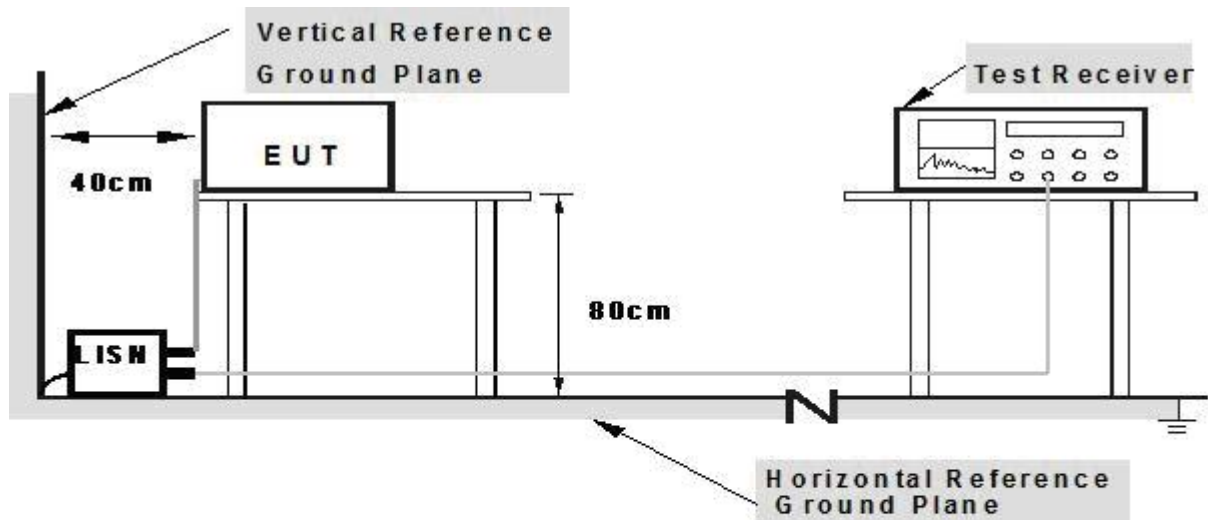

Note: 1. Support units were connected to second LISN.

2. Both of LISNs (AMN) are 80 cm from EUT and at least 80 cm from other units and other metal planes

3.1.4 EUT OPERATING CONDITIONS

The EUT tested system was configured as the statements of 2.3 Unless otherwise a special operating condition is specified in the follows during the testing.



3.1.5 TEST RESULTS

Not applicable for device which is DC Power supply.



3.2 RADIATED EMISSION MEASUREMENT

3.2.1 LIMITS OF RADIATED EMISSION MEASUREMENT

FREQUENCY (MHz)	Class A (at 10m)	Class B (at 3m)
	dBuV/m	dBuV/m
30 ~ 88	39.0	40.0
88 ~ 216	43.5	43.5
216 ~ 960	46.5	46.0
Above 960	49.5	54.0

Notes:

- (1) The limit for radiated test was performed according to as following:
FCC PART 15B /ICES-003.
- (2) The tighter limit applies at the band edges.
- (3) Emission level (dBuV/m)=20log Emission level (uV/m).

3.2.2 TEST PROCEDURE

- a. The measuring distance of at 10 m shall be used for measurements at frequency up to 1GHz. For frequencies above 1GHz, any suitable measuring distance may be used.
- b. The EUT was placed on the top of a rotating table 0.8 meters above the ground at a 10 meter open area test site. The table was rotated 360 degrees to determine the position of the highest radiation.
- c. The height of the equipment or of the substitution antenna shall be 0.8 m; the height of the test antenna shall vary between 1 m to 4 m. Both horizontal and vertical polarizations of the antenna are set to make the measurement.
- d. The initial step in collecting conducted emission data is a spectrum analyzer peak detector mode pre-scanning the measurement frequency range. Significant peaks are then marked and then Quasi Peak detector mode re-measured, above 1G Average detector mode will be instead.
- e. If the Peak Mode measured value compliance with and lower than Quasi Peak Mode Limit, the EUT shall be deemed to meet QP(AV) Limits and then no additional QP Mode measurement performed.
- f. For the actual test configuration, please refer to the related Item –EUT Test Photos.

3.2.3 TEST SETUP

(A) Radiated Emission Test Set-Up Frequency Below 1 GHz

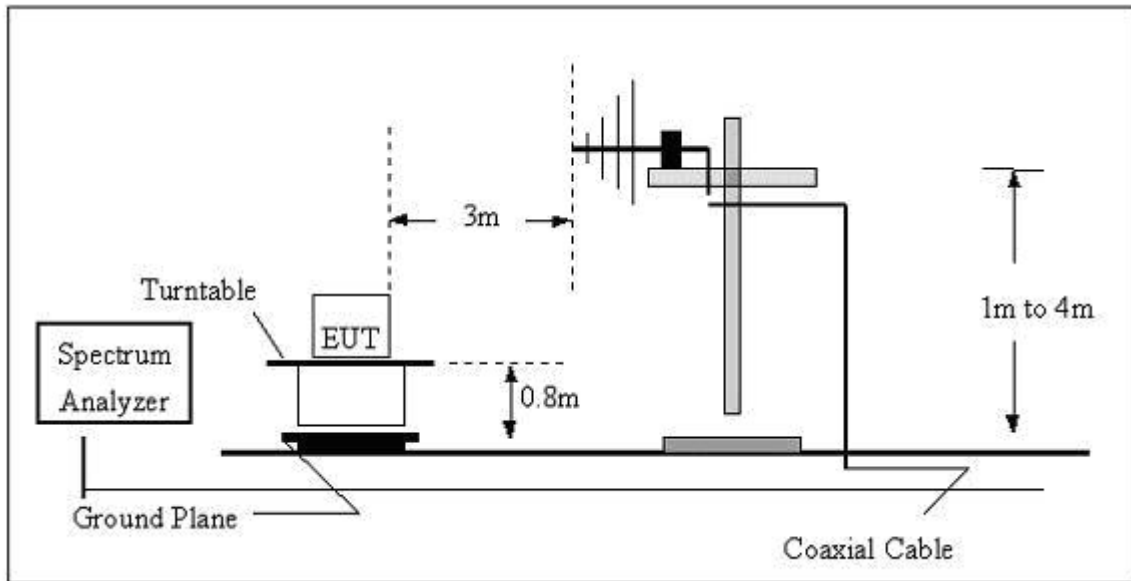

(B) Radiated Emission Test Set-Up Frequency Above 1GHz

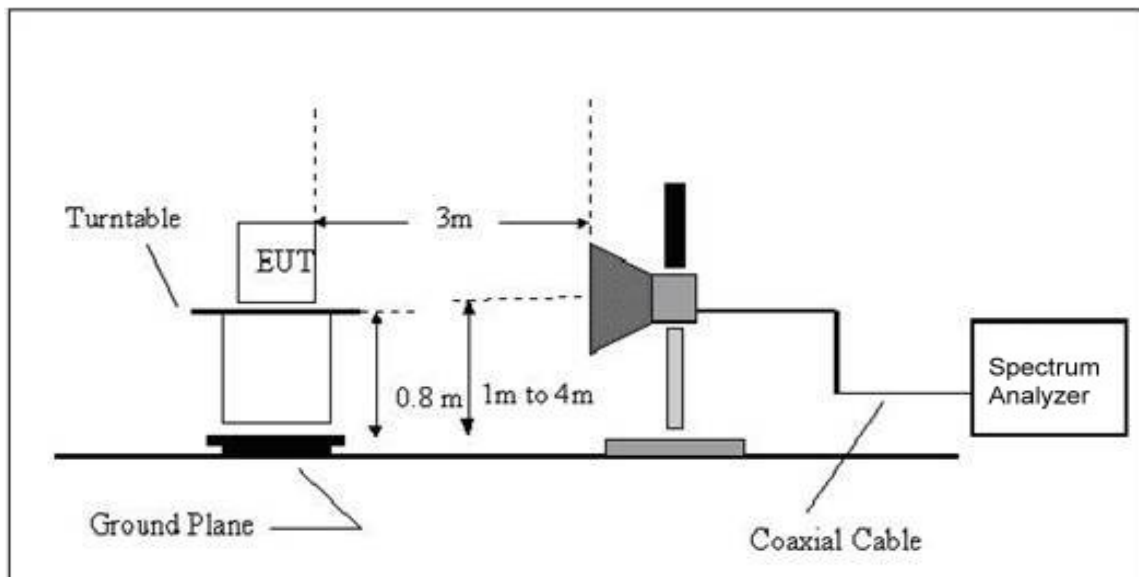

3.2.4 EUT OPERATING CONDITIONS

The EUT tested system was configured as the statements of 2.3 Unless otherwise a special operating condition is specified in the follows during the testing.



3.2.5 TEST RESULTS

EUT :	Industrial 4G LTE Cellular Router	Model Name :	M330-W
Temperature :	24 °C	Relative Humidity :	54%
Pressure :	1010 hPa	Test Date :	2019-08-09
Test Mode :	Running	Polarization :	Horizontal
Test Power :	DC 24V		

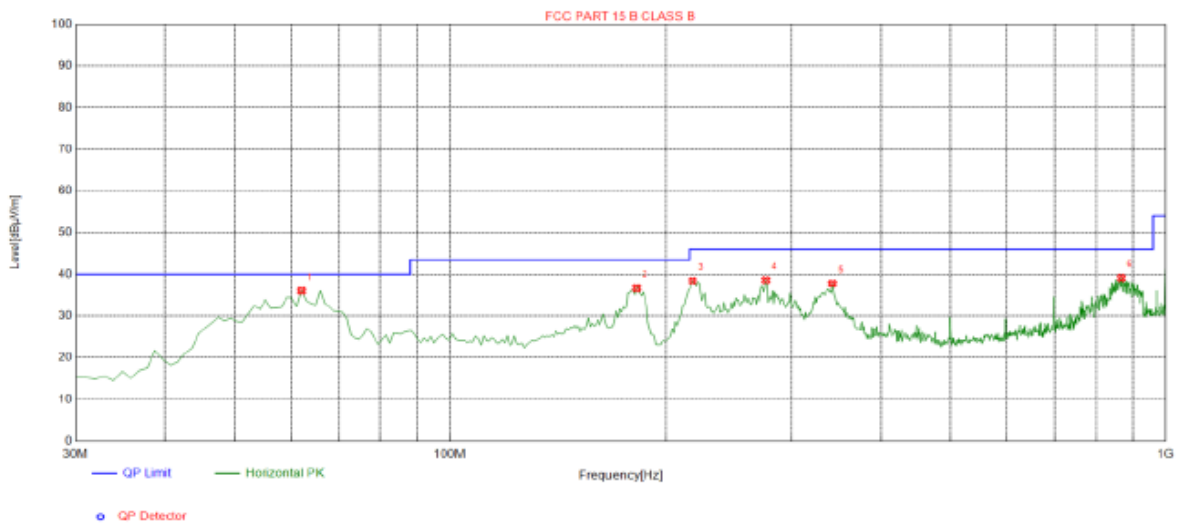

Suspected List								
NO.	Freq. [MHz]	Level [dBµV/m]	Factor [dB]	Limit [dBµV/m]	Margin [dB]	Height [cm]	Angle [°]	Polarity
1	62.0100	36.03	-15.66	40.00	3.97	100	359	Horizontal
2	182.290	36.62	-16.66	43.50	6.88	100	264	Horizontal
3	218.180	38.41	-14.60	46.00	7.59	100	212	Horizontal
4	276.380	38.59	-13.40	46.00	7.41	100	11	Horizontal
5	342.340	37.79	-11.65	46.00	8.21	100	187	Horizontal
6	867.110	39.14	-2.31	46.00	6.86	100	212	Horizontal

Remark: Transd = Cable lose + Antenna factor - Pre-amplifier; Margin = Limit – Level



EUT :	Industrial 4G LTE Cellular Router	Model Name :	M330-W
Temperature :	24 °C	Relative Humidity :	54%
Pressure :	1010 hPa	Test Date :	2019-08-09
Test Mode :	Running	Polarization :	Vertical
Test Power :	DC 24V		

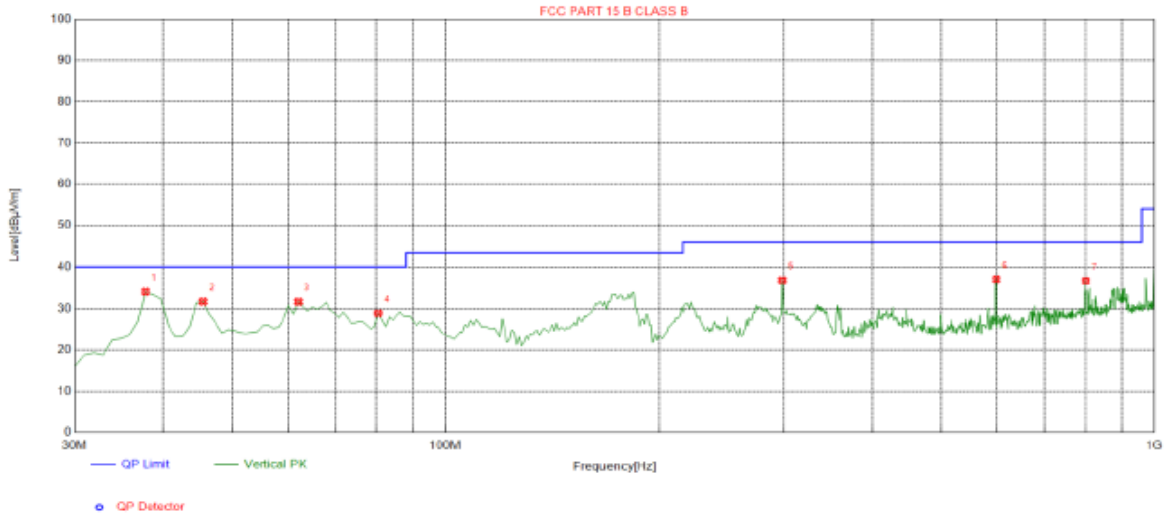

Suspected List								
NO.	Freq. [MHz]	Level [dBµV/m]	Factor [dB]	Limit [dBµV/m]	Margin [dB]	Height [cm]	Angle [°]	Polarity
1	37.7600	34.05	-15.26	40.00	5.95	100	21	Vertical
2	45.5200	31.73	-13.65	40.00	8.27	100	320	Vertical
3	62.0100	31.69	-15.66	40.00	8.31	100	184	Vertical
4	80.4400	28.89	-19.36	40.00	11.11	100	288	Vertical
5	298.690	36.83	-12.75	46.00	9.17	100	105	Vertical
6	598.420	37.10	-6.22	46.00	8.90	100	97	Vertical
7	800.180	36.70	-3.12	46.00	9.30	100	57	Vertical

Remark: Transd = Cable lose + Antenna factor - Pre-amplifier; Margin = Limit – Level



3.2.6 TEST RESULTS(Above 1GHz)

EUT :	Industrial 4G LTE Cellular Router	Model Name :	M330-W
Temperature :	24 °C	Relative Humidity :	54%
Pressure :	1010 hPa	Test Date :	2019.08.09
Test Mode :	Running		
Test Power :	DC 24V		

Note:

- 1) N/A - denotes test is not applicable in this test report
- 2) There was not any unintentional transmission in standby mode
- 3) Emission Level=Meter Reading +Factor, Margin=Emission Level-Limits

Polarization : Horizontal

Frequency	Meter Reading	Factor	Emission Level	Limits	Margin	Detector Type
(MHz)	(dBμV)	(dB)	(dBμV/m)	(dBμV/m)	(dB)	
1220.74	57.21	-11.37	45.84	74	-28.16	peak
1871.62	58.05	-15.38	42.67	74	-31.33	peak
2568.02	56.41	-8.62	47.79	74	-26.21	peak
3829.83	57.38	-6.17	51.21	74	-22.79	peak
4757.41	55.44	-4.52	50.92	74	-23.08	peak
4952.63	56.89	-5.64	51.25	74	-22.75	peak

Remark:

Factor = Antenna Factor + Cable Loss – Pre-amplifier

Polarization : Vertical

Frequency	Meter Reading	Factor	Emission Level	Limits	Margin	Detector Type
(MHz)	(dBμV)	(dB)	(dBμV/m)	(dBμV/m)	(dB)	
1159.58	57.11	-12.37	44.74	74	-29.26	peak
1204.74	56.78	-10.25	46.53	74	-27.47	peak
2755.69	57.56	-8.49	49.07	74	-24.93	peak
3246.32	58.41	-5.24	53.17	74	-20.83	peak
4916.15	55.25	-5.66	49.59	74	-24.41	peak
5945.95	57.8	-6.93	50.87	74	-23.13	peak

Remark:

Factor = Antenna Factor + Cable Loss – Pre-amplifier.

4. EUT TEST PHOTO

Radiated Emission

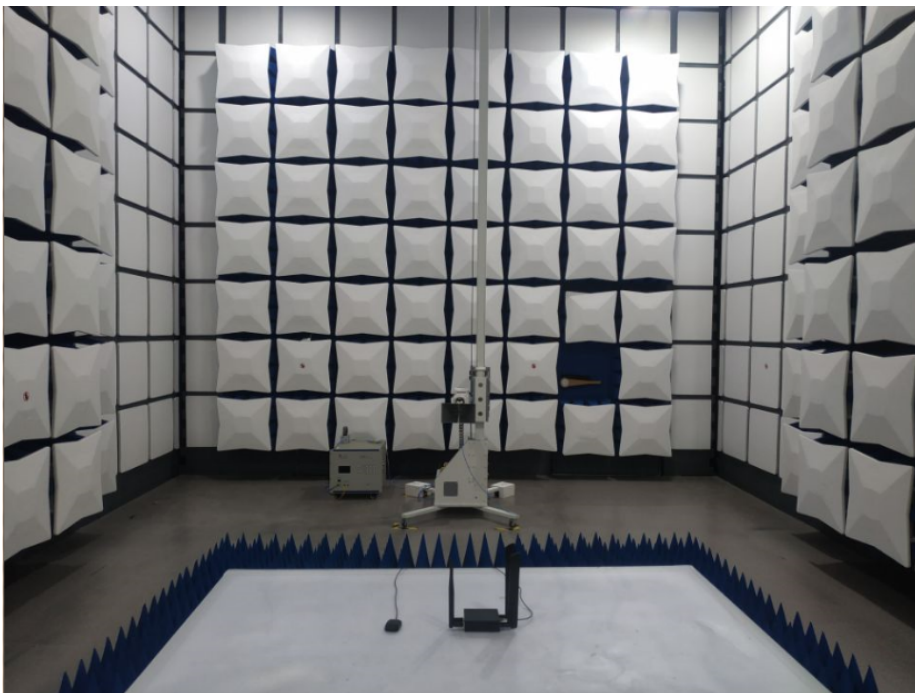
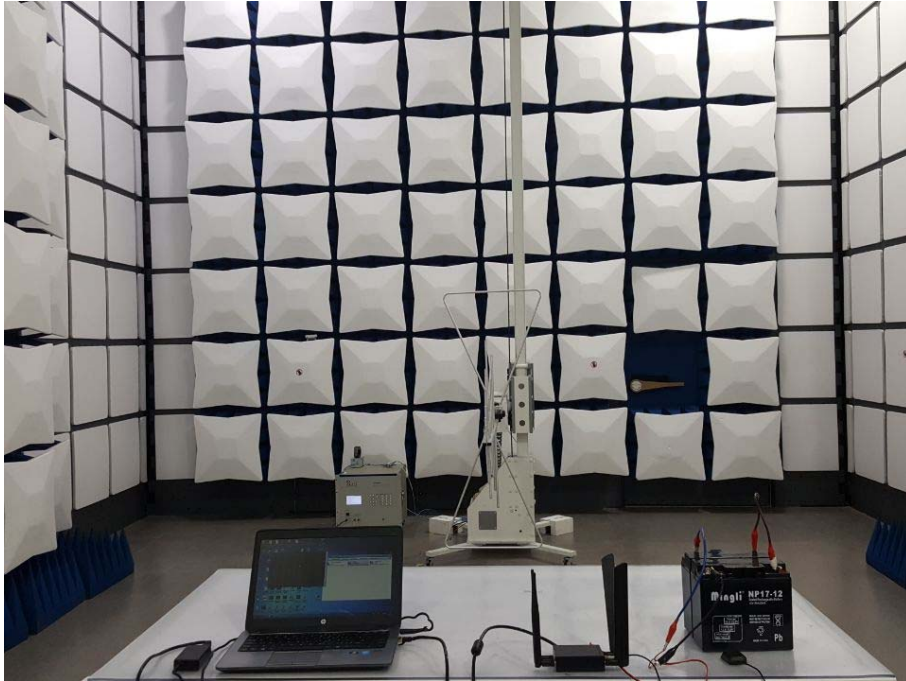



5. PHOTOS OF THE EUT

Reference to the reporter : ANNEX A of external photos and ANNEX B of internal photos

-----End of report-----