



No.:
FCCSZ2024-0065-RF4

TEST REPORT

FCC ID : 2AUA5-P2

NAME OF SAMPLE : Smart Desktop Terminal

APPLICANT : IMachine(Xiamen)Intelligent Devices Co.,Ltd.

CLASSIFICATION OF TEST : N/A

CVC Testing Technology (Shenzhen) Co., Ltd.



Applicant		Name:IMachine(Xiamen)Intelligent Devices Co.,Ltd. Address:7F-2,No.88-1,Tonghui South Road,Tongan,Xiamen,China.	
Manufacturer		Name:IMachine(Xiamen)Intelligent Devices Co.,Ltd. Address:7F-2,No.88-1,Tonghui South Road,Tongan,Xiamen,China.	
Equipment Under Test		Product Name:Smart Desktop Terminal Model/Type: P2 Additional Model/Type: See Chapter 2.1 Brand Name: N/A Serial NO.: N/A Sample NO.:2-1	
Date of Receipt.	2024.08.27	Date of Testing	2024.08.27~2024.10.22
Test Specification		Test Result	
FCC Part 15, Subpart E (15.407)		PASS	
Evaluation of Test Result	The equipment under test was found to comply with the requirements of the standards applied. Seal of CVC Issue Date:2024.11.06		
Compiled by: <u>Liang Jiatong</u> Name Signature	Reviewed by: <u>Mo Xianbiao</u> Name Signature	Approved by: <u>Dong Sanbi</u> Name Signature	
Other Aspects: NONE.			
Abbreviations:OK, Pass= passed Fail = failed N/A= not applicable EUT= equipment, sample(s) under tested			

This test report relates only to the EUT, and shall not be reproduced except in full, without written approval of CVC.



TABLE OF CONTENTS

1 SUMMARY OF TEST RESULTS	5
1.1 LIST OF TEST AND MEASUREMENT INSTRUMENTS	6
1.2 TEST LOCATION	6
2 GENERAL INFORMATION	7
2.1 GENERAL PRODUCT INFORMATION	7
2.2 TEST MODE APPLICABILITY AND TESTED CHANNEL DETAIL	9
2.3 DESCRIPTION OF SUPPORT UNITS	10
3 REQUIREMENTS AND PARAMETERS FOR DFS TEST	11
3.1 APPLICABILITY OF DFS REQUIREMENTS	11
3.2 DETECTION THRESHOLD VALUES	12
3.3 DFS RESPONSE REQUIREMENT VALUES	12
3.4 PARAMETERS OF DFS TEST SIGNALS	13
4 TEST RESULTS	14
4.1 TEST SETUP OF DFS	14
4.2 DFS DETECTION THRESHOLD	14
4.3 CHANNEL LOADING	15
4.4 CHANNEL CLOSING TRANSMISSION AND CHANNEL MOVE TIME	16
4.5 NON- OCCUPANCY PERIOD	17
5 PHOTOGRAPHS OF THE EUT	19



RELEASE CONTROL RECORD

ISSUE NO.	REASON FOR CHANGE	DATE ISSUED
FCCSZ2024-0065-RF4	Original release	2024.11.06



1 SUMMARY OF TEST RESULTS

The EUT has been tested according to the following specifications:

STANDARD SECTION	TEST TYPE AND LIMIT	RESULT	REMARK
FCC 15.407	Channel Move Time	PASS	464 ms
FCC 15.407	Channel Closing Transmission Time	PASS	200+aggregate of 3.9ms over remaining 10s period.
FCC 15.407	Non-Occupancy Period and Client Beacon Test	PASS	≥ 30 min

Note: Since the product is client without radar detection function, only Channel Move Time, Channel Closing Transmission Time and Non-Occupancy Period and Client Beacon Test are required to be performed



1.1 LIST OF TEST AND MEASUREMENT INSTRUMENTS

Equipment	Manufacturer	Model No.	Serial Number	Cal. interval	Cal. Due
Antenna Port Conducted Test					
Signal&Spectrum Analyzer	Rohde&Schwarz	FSV 30	104408	1 year	2025.4.28
#3Shielding room	MORI	443	N/A	3 year	2026.5.16
Wideband radio communication tester	Rohde&Schwarz	CMW 500	168778	1 year	2025.5.24
Analog signal Generator (100kHz ~ 40GHz)	Rohde&Schwarz	SMB 100A	181934	1 year	2025.4.27
Vector signal Generator (9kHz ~ 6GHz)	Keysight	N5182B	MY57301451	1 year	2025.4.28
Vector signal Generator (9kHz ~ 6GHz)	Rohde&Schwarz	SGT 100A	111724	1 year	2025.4.28
RF control unit(BT/WiFi)	Tonscend	JS0806-2-8CH	20E8060261	1 year	2025.4.28
Temperature and humidity meter	/	C193561457	C193561457	1 year	2025.4.28

1.2 TEST LOCATION

The tests and measurements refer to this report were performed by EMC testing Lab of CVC Testing Technology (Shenzhen) Co., Ltd.

Lab Address: No. 1301-14&16, Guanguang Road, Xinlan Community, Guanlan Subdistrict, Longhua District, Shenzhen, Guangdong, China

Post Code: 518110 Tel: 0755-23763060-8805

Fax: 0755-23763060 E-mail: sz-kf@cvc.org.cn

FCC(Test firm designation number: CN1363)

IC(Test firm CAB identifier number: CN0137)

CNAS(Test firm designation number: L16091)



2 GENERAL INFORMATION

2.1 GENERAL PRODUCT INFORMATION

PRODUCT	Smart Desktop Terminal
BRAND	N/A
TEST MODEL	P2
ADDITIONAL MODEL	<p>P1、 P2、 P3、 P5、 P6、 P7、 P8、 P9、 P1S、 P2S、 P3S、 P5S、 P6S、 P7S、 P8S、 P9S、 P1 MINI、 P2 MINI、 P3 MINI、 P5 MINI、 P6 MINI、 P7 MINI、 P8 MINI、 P9 MINI、 P1 PLUS、 P2 PLUS、 P3 PLUS、 P5 PLUS、 P1Pro、 P2Pro、 P3Pro、 P5Pro;</p> <p>A1、 A2、 A3、 A5、 A6、 A7、 A8、 A9、 A1S、 A2S、 A3S、 A5S、 A6S、 A7S、 A8S、 A9S、 A1 MINI、 A2 MINI、 A3 MINI、 A5 MINI、 A6 MINI、 A7 MINI、 A8 MINI、 A9 MINI、 A1 Plus、 A2 PLUS 、 A3 PLUS 、 A5 PLUS、 A1Pro、 A2Pro、 A3Pro 、 A5Pro、 A1 PlusPro、 A2PlusPro、 A3 PlusPro、</p> <p>K1、 K2、 K3、 K5、 K6、 K7、 K8、 K9、 K1S、 K2S、 K3S、 K5S、 K6S、 K7S、 K8S、 K9S、 K1 PLUS、 K1Pro、 L1、 L1 PLUS 、 L1Pro、 L1S、 M1、 M1 PLUS、 M1Pro、 M1S、 N1、 N1 PLUS、 N1Pro、 N1S、 Q1、 Q1 PLUS、 Q1Pro、 Q1S、 R1、 R1 PLUS、 R1Pro、 R1S、 S1、 S1 PLUS、 S1Pro、 S1S、 T1、 T1 PLUS、 T1Pro、 T1S、 U1、 U1 PLUS、 U1Pro、 U1S</p> <p>P***(*=0-9 or A-Z or MINI or PLUS or Pro or PLUS Pro or blank) A***(*=0-9 or A-Z or MINI or PLUS or Pro or PLUS Pro or blank) K***(*=0-9 or A-Z or MINI or PLUS or Pro or PLUS Pro or blank) L***(*=0-9 or A-Z or MINI or PLUS or Pro or PLUS Pro or blank) M***(*=0-9 or A-Z or MINI or PLUS or Pro or PLUS Pro or blank) N***(*=0-9 or A-Z or MINI or PLUS or Pro or PLUS Pro or blank) Q***(*=0-9 or A-Z or MINI or PLUS or Pro or PLUS Pro or blank) R***(*=0-9 or A-Z or MINI or PLUS or Pro or PLUS Pro or blank) S***(*=0-9 or A-Z or MINI or PLUS or Pro or PLUS Pro or blank) T***(*=0-9 or A-Z or MINI or PLUS or Pro or PLUS Pro or blank) U***(*=0-9 or A-Z or MINI or PLUS or Pro or PLUS Pro or blank)</p>
POWER SUPPLY	DC 12V From Adapter
MODULATION TECHNOLOGY	OFDM
MODULATION TYPE	256QAM, 64QAM, 16QAM, QPSK, BPSK for OFDM
TRANSFER RATE	802.11a: up to (54Mbps) 802.11n: up to (HT20/40 MCS7) 802.11ac: up to (HT80 MCS9),
OPERATING FREQUENCY	5260 ~ 5320MHz, 5500 ~ 5700MHz
NUMBER OF CHANNEL	See item 2.3



ANTENNA TYPE(NOTE 4)	WiFi Antenna(Aux):FPC Antenna with 4.04dBi gain for 5G WiFi								
DEVICE TYPE	<input type="checkbox"/> Master <input checked="" type="checkbox"/> Client without radar detection <input type="checkbox"/> Client with radar detection								
I/O PORTS	Refer to user's manual								
NOTE:									
<ol style="list-style-type: none"> For a more detailed features description, please refer to the manufacturer's specifications or the user's manual. For the test results, the EUT had been tested with all conditions. But only the worst case was shown in test report. EUT photo refer to report (Report NO.: FCCSZ2024-0065-EUT). Since the above data and/or information is provided by the client, CVC is not responsible for the authenticity, integrity and results of the data and information and/or the validity of the conclusion Test Model(P2) and other model the only difference is the model name The device shall automatically discontinue transmission in case of either absence of information to transmit or operational failure. 									
<table border="1"> <thead> <tr> <th>MODULATION MODE</th> <th>TX FUNCTION</th> </tr> </thead> <tbody> <tr> <td>802.11a</td> <td>SISO</td> </tr> <tr> <td>802.11n</td> <td>SISO</td> </tr> <tr> <td>802.11ac</td> <td>SISO</td> </tr> </tbody> </table>		MODULATION MODE	TX FUNCTION	802.11a	SISO	802.11n	SISO	802.11ac	SISO
MODULATION MODE	TX FUNCTION								
802.11a	SISO								
802.11n	SISO								
802.11ac	SISO								

	Adapter1	Adapter2
Brand	MASS POWER	DA-JING
Model No.:	S050-1A120400B3	ADP60A-12500A1
Input:	100V-240V,50/60Hz, 1.5A	100V-240V,50/60Hz, 1.5A
Output:	12V/4A	12V/5A



2.2 TEST MODE APPLICABILITY AND TESTED CHANNEL DETAIL

BANDWIDTH	CHANNEL	TEST TYPE AND LIMIT
80MHz	CH106(5530MHz)	Channel Move Time
		Channel Closing Transmission Time
		Non-Occupancy Period and Client Beacon Test

Remark:
This test was investigated for different bandwidth (20MHz, 40MHz, 80MHz). The following plots was worst case.



2.3 DESCRIPTION OF SUPPORT UNITS

The EUT has been tested as an independent unit together with other necessary accessories or support units. The following support units or accessories were used to form a representative test configuration during the tests.

Support Equipment							
NO	Description	Brand	Model No.	FCC ID	Supplied by		
1	Wireless router	xiaomi	AX3600	Q87-WRT3200ACM	Lab		
2	Laptop	Lenovo	K4e-ARE120	/	Lab		
Support Cable							
NO	Description	Quantity (Number)	Length (m)	Detachable (Yes/ No)	Shielded (Yes/ No)	Cores (Number)	Supplied by
1	N/A	N/A	N/A	N/A	N/A	N/A	N/A



3 REQUIREMENTS AND PARAMETERS FOR DFS TEST

3.1 APPLICABILITY OF DFS REQUIREMENTS

APPLICABILITY OF DFS REQUIREMENTS PRIOR TO USE A CHANNEL

REQUIREMENT	OPERATIONAL MODE		
	MASTER	CLIENT WITHOUT RADAR DETECTION	CLIENT WITH RADAR DETECTION
Non-Occupancy Period	✓	✓	✓
DFS Detection Threshold	✓	Not required	✓
Channel Availability Check Time	✓	Not required	Not required
Uniform Spreading	✓	Not required	Not required
U-NII Detection Bandwidth	✓	Not required	✓

APPLICABILITY OF DFS REQUIREMENTS DURING NORMAL OPERATION

REQUIREMENT	OPERATIONAL MODE		
	MASTER	CLIENT WITHOUT RADAR DETECTION	CLIENT WITH RADAR DETECTION
DFS Detection Threshold	✓	Not required	✓
Channel Closing Transmission Time	✓	✓	✓
Channel Move Time	✓	✓	✓
U-NII Detection Bandwidth	✓	Not required	✓



3.2 DETECTION THRESHOLD VALUES

DFS DETECTION THRESHOLDS FOR MASTER DEVICES AND CLIENT DEVICES WITH RADAR DETECTION

MAXIMUM TRANSMIT POWER	VALUE (SEE Note 1 and 2)
≥ 200 milliwatt	-64 dBm
< 200 milliwatt	-62 dBm

Note 1: This is the level at the input of the receiver assuming a 0 dBi receive antenna.

Note 2: Throughout these test procedures an additional 1 dB has been added to the amplitude of the test transmission waveforms to account for variations in measurement equipment. This will ensure that the test signal is at or above the detection threshold level to trigger a DFS response.

3.3 DFS RESPONSE REQUIREMENT VALUES

PARAMETER	VALUE
Non-occupancy period	Minimum 30 minutes
Channel Availability Check Time	60 seconds
Channel Move Time	10 seconds See Note 1.
Channel Closing Transmission Time	200 milliseconds + an aggregate of 60 milliseconds over remaining 10 second period. See Notes 1 and 2.
U-NII Detection Bandwidth	100% of the UNII transmission power bandwidth. See Note 3.

Note 1: The instant that the Channel Move Time and the Channel Closing Transmission Time begins is as follows:

- For the Short Pulse Radar Test Signals this instant is the end of the Burst.
- For the Frequency Hopping radar Test Signal, this instant is the end of the last radar Burst generated.
- For the Long Pulse Radar Test Signal this instant is the end of the 12 second period defining the Radar Waveform.

Note 2: The Channel Closing Transmission Time is comprised of 200 milliseconds starting at the beginning of the Channel Move Time plus any additional intermittent control signals required to facilitate a Channel move (an aggregate of 60 milliseconds) during the remainder of the 10 second period. The aggregate duration of control signals will not count quiet periods in between transmissions.

Note 3: During the U-NII Detection Bandwidth detection test, radar type 1 is used and for each frequency step the minimum percentage of detection is 90 percent. Measurements are performed with no data traffic.



3.4 PARAMETERS OF DFS TEST SIGNALS

Step intervals of 0.1 microsecond for Pulse Width, 1 microsecond for PRI, 1 MHz for chirp width and 1 for the number of pulses will be utilized for the random determination of specific test waveforms.

Short Pulse Radar Test Waveforms

Radar Type	Pulse Width (µsec)	PRI (µsec)	Number of Pulses	Minimum Percentage of Successful Detection	Minimum Number of Trials
0	1	1428	18	See Note 1	See Note 1
1	1	Test A Test B	Roundup $\left\{ \begin{matrix} \frac{1}{360} \\ \frac{19 \cdot 10^3}{PRI \cdot \mu sec} \end{matrix} \right\}$	60%	30
2	1-5	150-230	23-29	60%	30
3	6-10	200-500	16-18	60%	30
4	11-20	200-500	12-16	60%	30
Aggregate (Radar Types 1-4)				80%	120
Note 1: Short Pulse Radar Type 0 should be used for the detection bandwidth test, channel move time, and channel closing time tests.					

LONG PULSE RADAR TEST WAVEFORM

RADAR TYPE	PULSE WIDTH (µsec)	CHIRP WIDTH (MHz)	PRI (µsec)	NUMBER OF PULSES PER BURST	NUMBER OF BURSTS	MINIMUM PERCENTAGE OF SUCCESSFUL DETECTION	MINIMUM NUMBER OF TRIALS
5	50-100	5-20	1000-2000	1-3	8-20	80%	30

FREQUENCY HOPPING RADAR TEST WAVEFORM

RADAR TYPE	PULSE WIDTH (µsec)	PRI (µsec)	PULSES PER HOP	HOPPING RATE (kHz)	HOPPING SEQUENCE LENGTH (msec)	MINIMUM PERCENTAGE OF SUCCESSFUL DETECTION	MINIMUM NUMBER OF TRIALS
6	1	333	9	0.333	300	70%	30

4 TEST RESULTS

4.1 TEST SETUP OF DFS

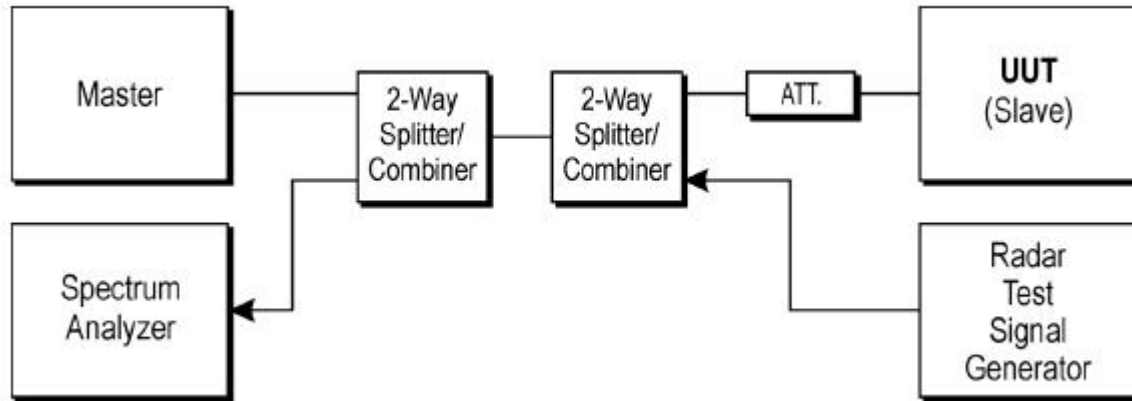

4.2 DFS DETECTION THRESHOLD

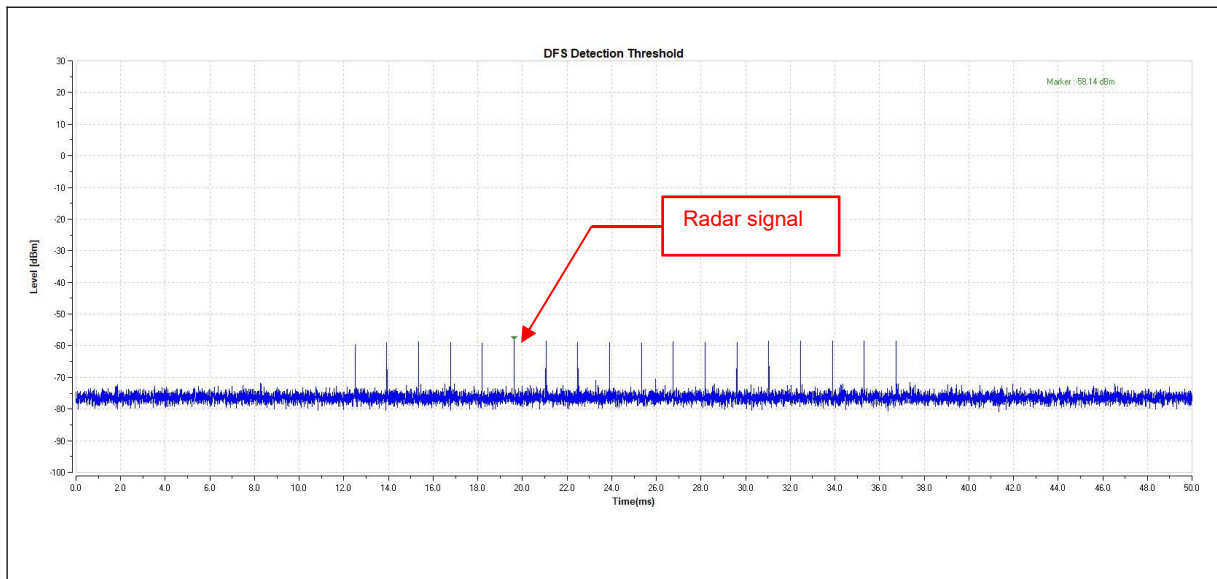



4.3 CHANNEL LOADING

The radar signal was the same as transmitted channels, and injected into the antenna port of AP (master) with radar signal, measured the channel shutdown. The slave transmitted the test data to master, the transmitted duty cycle is 25.1%.

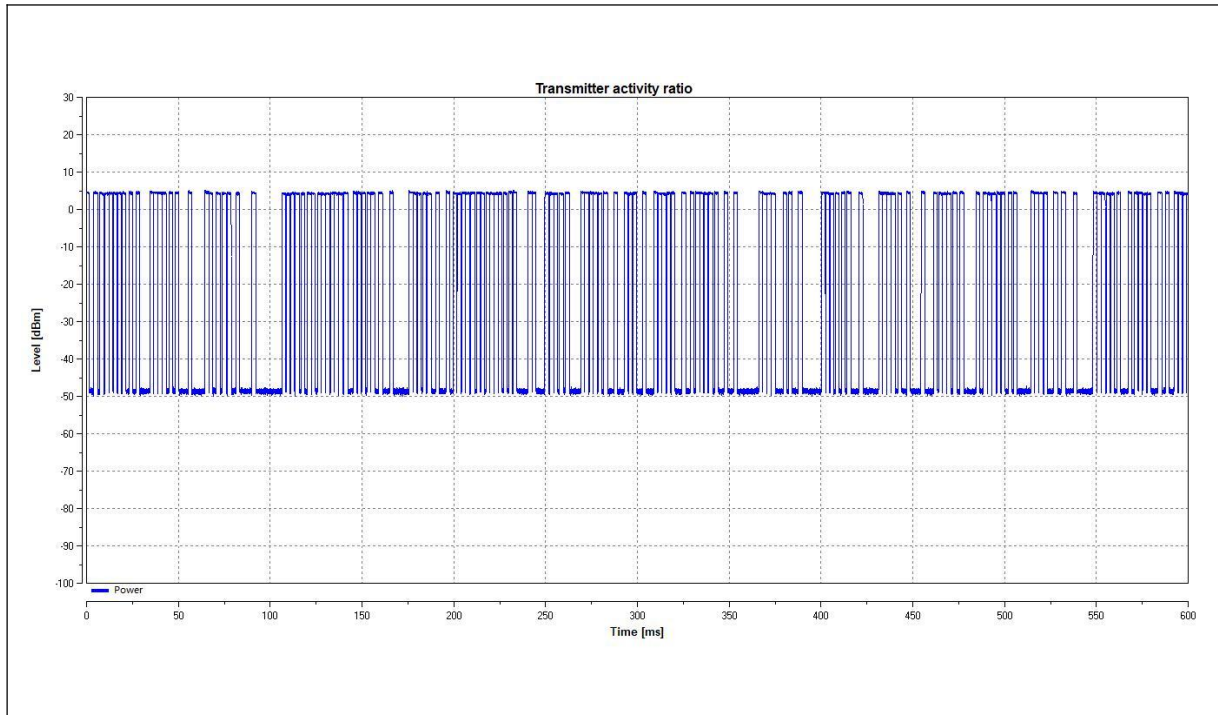

Note: Traffic signal: from slave transmit to master.



4.4 CHANNEL CLOSING TRANSMISSION AND CHANNEL MOVE TIME

Radar Signal 0

Channel Move Time(ms)	464	Channel Closing Transmission Time(ms)	200+3.9
-----------------------	-----	---------------------------------------	---------

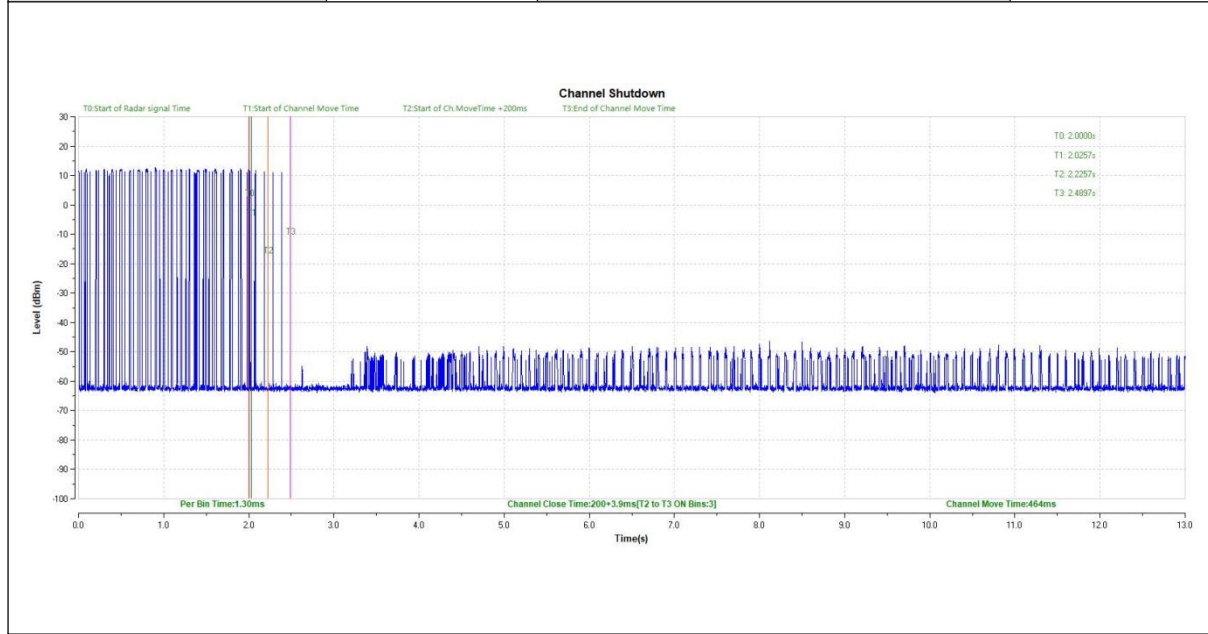

NOTE:

- 1. T0 denotes the Start of Radar Signal Time
- 2. T1 denotes the Start of Channel Move Time.
- 3. T2 denotes the Start of Channel Move Time + 200ms.
- 4. T3 denotes the End of Channel Move Time.
- 5. Per Bin Time = Sweep time (13000ms) / Sweep Point Bins (10000) = 1.3ms
- 6. Channel Closing Transmission Time = 200 + ON Bins * Per Bin Time



4.5 NON- OCCUPANCY PERIOD

- 1) Test results demonstrating an associated client link is established with the master on a test frequency
- 2) The client and DFS-certified master device are associated, and system testing will be performed with channel-loading for a non-occupancy period test.
- 3). The device transmits one type of radar as specified in the DFS Order.
- 4) The test frequency has been monitored to ensure no transmission of any type has occurred for 30 minutes;
Note: If the client moves with the master, the device is considered compliant if nothing appears in the client non-occupancy period test. For devices that shut down (rather than moving channels), no beacons should appear;
- 5)An analyzer plot that contains a single 30-minute sweep on the original test frequency.

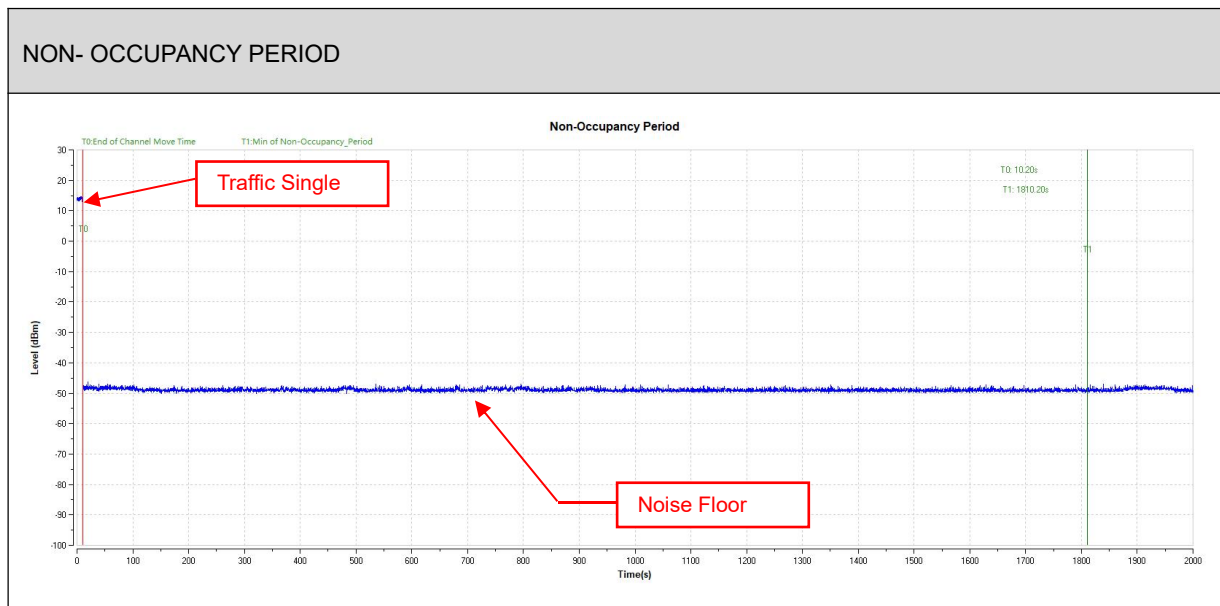



Master was off.

During the 30 minutes observation time, The UUT did not make any transmissions in the DFS band after UUT power up

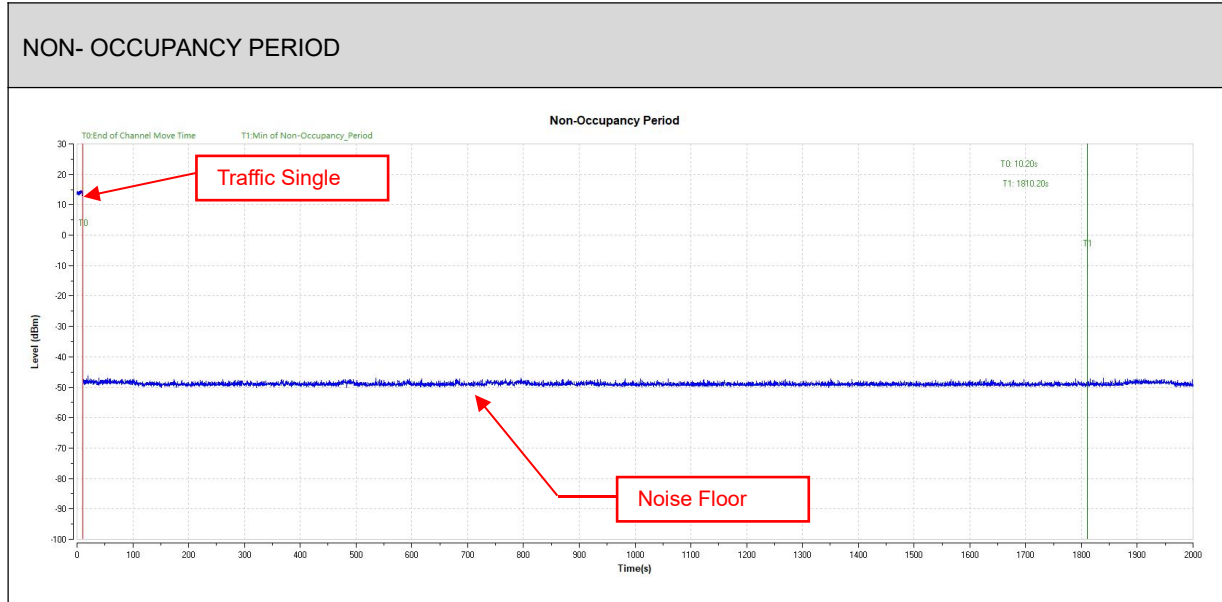



5 PHOTOGRAPHS OF THE EUT

Please refer to the attached file (External Photos report and Internal Photos).

----- End of the Report -----



Important

- (1) The test report is invalid without the official stamp of CVC;
- (2) Any part photocopies of the test report are forbidden without the written permission from CVC;
- (3) The test report is invalid without the signatures of Approval and Reviewer;
- (4) The test report is invalid if altered;
- (5) Objections to the test report must be submitted to CVC within 15 days.
- (6) Generally, commission test is responsible for the tested samples only.
- (7) As for the test result “-” or “N” means “not applicable”, “/” means “not test”, “P” means “pass” and “F” means “fail”

Address: No. 1301-14&16, Guanguang Road, Xinlan Community, Guanlan Subdistrict, Longhua District, Shenzhen, Guangdong, China

Post Code: 518110 Tel: 0755-23763060-8805

Fax: 0755-23763060 E-mail: sz-kf@cvc.org.cn

<http://www.cvc.org.cn>