



MK8663-BLE module data manual

Shenzhen Manka IOT Electronic Co.,Ltd
Web site: www.szmanka.com

Disclaimer and copyright notice:

The information in this article, including the URL address for reference, is subject to change without notice. The document is provided "as is" without any guarantee responsibility, including any guarantee for merchantability, suitability for a specific purpose, or non-infringement, and any guarantee mentioned elsewhere in any proposal, specification or sample. This document does not take any responsibility, including the responsibility for infringement of any patent rights caused by the use of the information in this document. This document does not grant any license for the use of intellectual property rights in estoppel or other ways, whether express or implied. The test data obtained in the article are all obtained from the test of Shenzhen Manka IOT Electronic Co., Ltd Laboratory, and the actual results may vary slightly.

The Bluetooth Alliance member logo is owned by the Bluetooth Alliance.

All brand names, trademarks and registered trademarks mentioned in this article are the property of their respective owners, and it is hereby declared.

The final interpretation right belongs to Shenzhen Manka IOT Electronic Co., Ltd.

Note:

Due to product version upgrades or other reasons, the contents of this manual may be changed. Shenzhen Manka IOT Electronics Co., Ltd reserves the right to modify the contents of this manual without any notice or prompt. This manual is only used as a guide. Shenzhen Manka IOT Electronics Co., Ltd does its best to provide accurate information in this manual, but the company does not guarantee that the content of the manual is completely free of errors, and all statements, information and suggestions in this manual are not It constitutes any express or implied guarantee.

FCC ID:2AU9B-A8663

Document development/revision/abolishment resume

Version number	Formulate/modify content	Maker	Time
1.0	First draft	ZYQ	2021.04

Contents

1.Product description.....	4
2.Electrical parameters.....	4
3.Physical dimension.....	5
4.Pin definition.....	6
5.Schematic diagram.....	7
6.Design guidance.....	7

1.Product description

The MK8663-BLE module is a 2.4G Bluetooth single chip design based on the TLSR8269 chip. Compatible with Bluetooth 4.2 and MESH networking and other functions. The devices communicate through peer-to-peer star network self-organizing network and Bluetooth broadcast to ensure timely response in the case of multiple devices. It is mainly used in smart light control products.

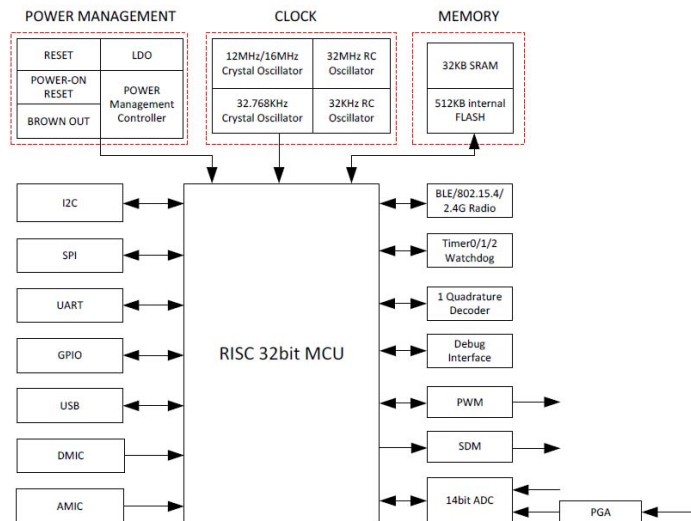

TLSR8269 Functional block diagram

2.Electrical parameters

Main feature name	Specifications
Supply voltage	2.0~3.6Vdc Recommend: 3.3V >30mA
Operating temperature	-20~+85°C Recommend: 50°C
Storage temperature	-20~+125°C
Wireless standard	Bluetooth 5.0 BLE/802.15.4/2.4GHz
Transmit power	Tx output power: +7dBm.
Received power	-92dBm@BLE 1Mbps, -97dBm@ IEEE802.15.4 250Kbps, -88dBm @ 2.4G proprietary 2Mbps mode.
Power consumption	Receiver mode current (Transceiver only): 12mA Transmitter mode current (Transceiver only): 15mA @0dBm power, 22mA @max power Suspend mode current: 10uA (IO wakeup), 12uA (Timer wakeup) Deep sleep mode current: 1.7uA

3.Physical dimension

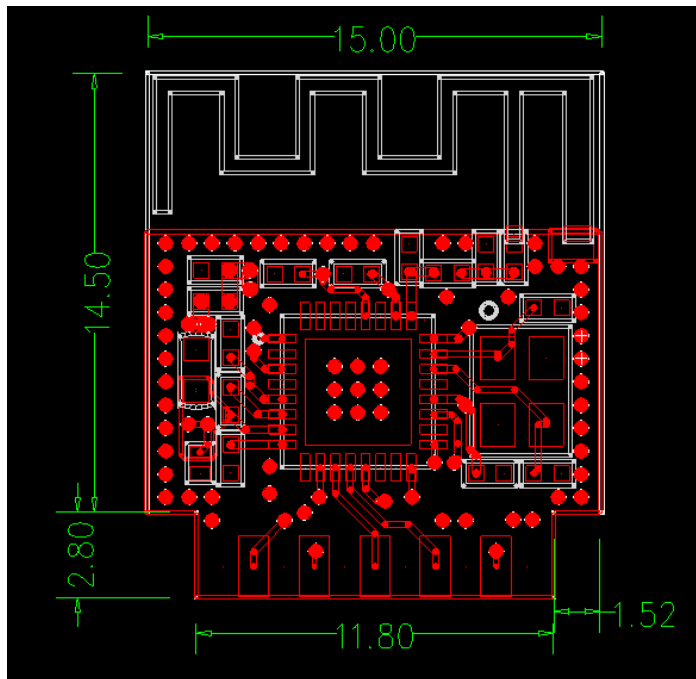

4.Pin definition

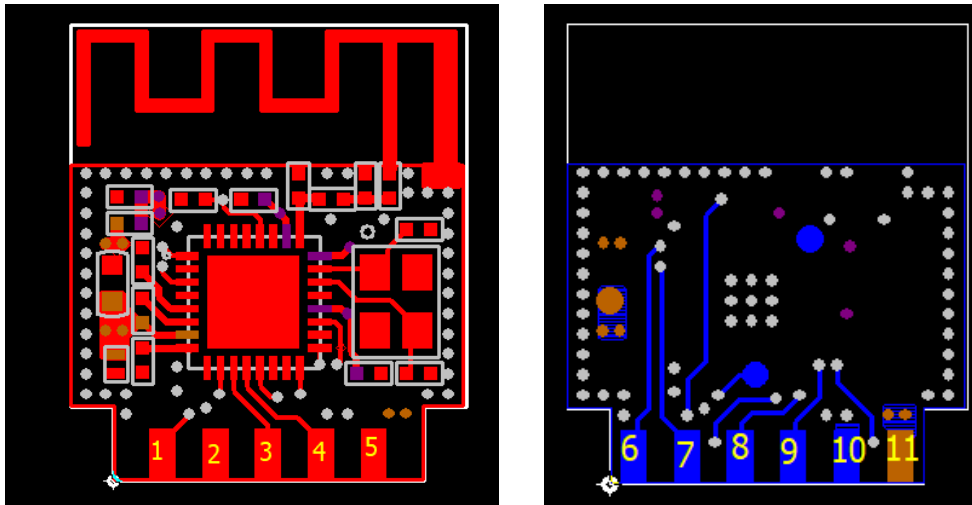

Note: The module currently uses bulb lights and light strip controllers (different firmware interface definitions are different).

PIN	PIN function		
1	PWM5		
2	PWM4		
3	PWM3		
4	IO13		
5	RST		
6	PWM_1		
7	PWM_2		
8	UART_TX		
9	UART_RX		
10	GND		
11	VDD-3V3		

(1) For the installation position on the motherboard, the following two methods are recommended:

Solution 1: Put the module on the edge of the main board, and the antenna area extends out of the edge of the main board.

(2) Solution 2: Put the module on the edge of the motherboard, and hollow out an area at the antenna position on the edge of the motherboard.

In order to meet the performance of the on-board antenna, it is forbidden to place metal parts around the antenna, away from high-frequency components, Such as: transformers, coils, relays, etc.

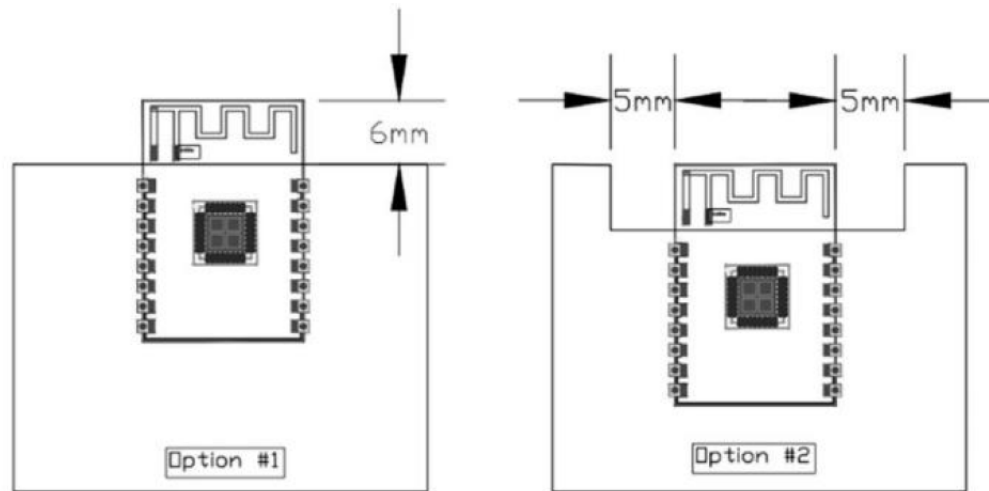

FCC statements:

This device complies with part 15 of the FCC rules. Operation is subject to the following two conditions:

- (1) this device may not cause harmful interference, and
- (2) this device must accept any interference received, including interference that may cause undesired operation.

NOTE: The manufacturer is not responsible for any radio or TV interference caused by unauthorized modifications or changes to this equipment. Such modifications or changes could void the user's authority to operate the equipment.

NOTE: This equipment has been tested and found to comply with the limits for a Class B digital device, pursuant to part 15 of the FCC Rules. These limits are designed to provide reasonable protection against harmful interference in a residential installation. This equipment generates uses and can radiate radio frequency energy and, if not installed and used in accordance with the instructions, may cause harmful interference to radio communications. However, there is no guarantee that interference will not occur in a particular installation. If this equipment does cause harmful interference to radio or television reception, which can be determined by turning the equipment off and on, the user is encouraged to try to correct the interference by one or more of the following measures:

- Reorient or relocate the receiving antenna.

- Increase the separation between the equipment and receiver.
- Connect the equipment into an outlet on a circuit different from that to which the receiver is connected.
- Consult the dealer or an experienced radio/TV technician for help.

The device has been evaluated to meet general RF exposure requirement, The device can be used in portable exposure condition without restriction Federal Communication Commission (FCC) Radiation Exposure Statement Power is so low that no RF exposure calculation is needed.