



RF TEST REPORT

Applicant Smawave Technology Co. ,Ltd
FCC ID 2AU8HSRP410-B
Product LTE CPE
Brand Smawave
Model SRP410-b
Report No. R2012A0860-R1
Issue Date December 25, 2020

TA Technology (Shanghai) Co., Ltd. tested the above equipment in accordance with the requirements in **FCC CFR47 Part 15E (2019)**. The test results show that the equipment tested is capable of demonstrating compliance with the requirements as documented in this report.

Prepared by: Peng Tao

Approved by: Kai Xu

TA Technology (Shanghai) Co., Ltd.

No.145, Jintang Rd, Tangzhen Industry Park, Pudong Shanghai, China

TEL: +86-021-50791141/2/3

FAX: +86-021-50791141/2/3-8000

TABLE OF CONTENT

| | |
|---|----|
| 1. Test Laboratory | 4 |
| 1.1. Notes of the test report..... | 4 |
| 1.2. Test facility | 4 |
| 1.3. Testing Location..... | 4 |
| 2. General Description of Equipment under Test..... | 5 |
| 2.1. Applicant and Manufacturer Information..... | 5 |
| 2.2. General information..... | 5 |
| 3. Applied Standards | 6 |
| 4. Test Configuration | 7 |
| 5. Test Case Results | 8 |
| 5.1. Unwanted Emission | 8 |
| 6. Main Test Instruments..... | 20 |

Summary of measurement results

| Number | Test Case | Clause in FCC rules | Verdict |
|---|--------------------------------|---------------------|-----------------------|
| 1 | Average conducted output power | 15.407(a) | Refer to the Original |
| 2 | Occupied bandwidth | 15.407(e) | Refer to the Original |
| 3 | Frequency stability | 15.407(g) | Refer to the Original |
| 4 | Power spectral density | 15.407(a) | Refer to the Original |
| 5 | Unwanted Emissions | 15.407(b) | PASS |
| 6 | Conducted Emissions | 15.207 | Refer to the Original |
| Test Date: December 10 2020 ~ December 20 2020 | | | |
| Note: All indications of Pass/Fail in this report are opinions expressed by TA Technology (Shanghai) Co., Ltd. based on interpretations and/or observations of test results. Measurement Uncertainties were not taken into account and are published for informational purposes only. | | | |

SRP410-b (Report No.: R2012A0860-R1) is a variant model of SRP410-b (Report No.: R2001A0016-R1). Only the LTE antenna was changed. Test values partial duplicated from original for variant. In this report, only Unwanted Emissions were tested for variant. The detailed product change description please refers to the Product Change Description_Variant SRP410-b.

1. Test Laboratory

1.1. Notes of the test report

This report shall not be reproduced in full or partial, without the written approval of **TA technology (shanghai) co., Ltd.** The results documented in this report apply only to the tested sample, under the conditions and modes of operation as described herein. Measurement Uncertainties were not taken into account and are published for informational purposes only. This report is written to support regulatory compliance of the applicable standards stated above.

1.2. Test facility

FCC (Designation number: CN1179, Test Firm Registration Number: 446626)

TA Technology (Shanghai) Co., Ltd. has been listed on the US Federal Communications Commission list of test facilities recognized to perform measurements.

A2LA (Certificate Number: 3857.01)

TA Technology (Shanghai) Co., Ltd. has been listed by American Association for Laboratory Accreditation to perform measurement.

1.3. Testing Location

Company: TA Technology (Shanghai) Co., Ltd.
Address: No.145, Jintang Rd, Tangzhen Industry Park, Pudong
City: Shanghai
Post code: 201201
Country: P. R. China
Contact: Xu Kai
Telephone: +86-021-50791141/2/3
Fax: +86-021-50791141/2/3-8000
Website: <http://www.ta-shanghai.com>
E-mail: xukai@ta-shanghai.com

2. General Description of Equipment under Test

2.1. Applicant and Manufacturer Information

| | |
|-----------------------------|---|
| Applicant | Smawave Technology Co. ,Ltd |
| Applicant address | 3/F, Building 8, 1001 North Qinzhou Road, Xuhui District, Shanghai, China |
| Manufacturer | Smawave Technology Co. ,Ltd |
| Manufacturer address | 3/F, Building 8, 1001 North Qinzhou Road, Xuhui District, Shanghai, China |

2.2. General information

| EUT Description | |
|---|-----------------------|
| Model | SRP410-b |
| IMEI | 862165040679399 |
| Hardware Version | SGL6010_V1.0 |
| Software Version | SG626U_V1.0.0 |
| Power Supply | External Power Supply |
| Antenna Type | External Antenna |
| Antenna Gain | 14dBi |
| Modulation Type | (LTE)QPSK 16QAM; |
| Operating Frequency Range(s) | 5725-5850MHz |
| Operating temperature range: | -40 ° C to 70° C |
| Operating voltage range: | 9 V to 14V |
| State DC voltage: | 12V |
| Note:1. The EUT is sent from the applicant to TA and the information of the EUT is declared by the applicant. | |

3. Applied Standards

According to the specifications of the manufacturer, it must comply with the requirements of the following standards:

Test standards:

FCC CFR47 Part 15E (2019) Unlicensed National Information Infrastructure Devices

ANSI C63.10 (2013)

Reference standard:

KDB 789033 D02 General UNII Test Procedures New Rules v02r01

4. Test Configuration

Test Mode

The EUT has been associated with peripherals and configuration operated in a manner tended to maximize its emission characteristics in a typical application.

The radiated emission was measured in the following position: EUT stand-up position (Z axis), lie-down position (X, Y axis). The worst emission was found in lie-down position (X axis) and the worst case was recorded.

5. Test Case Results

5.1. Unwanted Emission

Ambient condition

| Temperature | Relative humidity | Pressure |
|-------------|-------------------|----------|
| 23°C ~25°C | 45%~50% | 101.5kPa |

Method of Measurement

The test set-up was made in accordance to the general provisions of ANSI C63.10-2013. The Equipment Under Test (EUT) was set up on a non-conductive table in the semi-anechoic chamber. The test was performed at the distance of 3 m between the EUT and the receiving antenna. The radiated emissions measurements were made in a typical installation configuration. Sweep the whole frequency band range from 9kHz to the 10th harmonic of the carrier, and the emissions less than 20 dB below the permissible value are reported.

During the test, the height of receive antenna shall be moved from 1 to 4 meters, and the antenna shall be performed under horizontal and vertical polarization. The turntable shall be rotated from 0 to 360 degrees for detecting the maximum of radiated spurious signal level. The measurements shall be repeated with orthogonal polarization of the test antenna. The data of cable loss and antenna factor has been calibrated in full testing frequency range before the testing.

Set the spectrum analyzer in the following:

Below 1GHz (detector: Peak and Quasi-Peak)

RBW=100kHz / VBW=300kHz / Sweep=AUTO

Above 1GHz (detector: Peak):

I) Peak emission levels are measured by setting the instrument as follows:

- 1) RBW = 1 MHz.
- 2) VBW \geq [3 × RBW]
- 3) Detector = peak.
- 4) Sweep time = auto.
- 5) Trace mode = max hold.
- 6) Allow sweeps to continue until the trace stabilizes. Note that if the transmission is not continuous, then the time required for the trace to stabilize will increase by a factor of approximately 1 / D, where D is the duty cycle.

II) Average emission levels are measured by setting the instrument as follows:

- a) RBW = 1 MHz.
- b) VBW \geq [3 × RBW].
- c) Detector = RMS (power averaging), if [span / (# of points in sweep)] \leq RBW / 2. Satisfying this condition can require increasing the number of points in the sweep or reducing the span. If the condition is not satisfied, then the detector mode shall be set to peak.
- d) Averaging type = power (i.e., rms) (As an alternative, the detector and averaging type may be set

for linear voltage averaging. Some instruments require linear display mode to use linear voltage averaging. Log or dB averaging shall not be used.)

e) Sweep time = auto.

f) Perform a trace average of at least 100 traces if the transmission is continuous. If the transmission is not continuous, then the number of traces shall be increased by a factor of $1 / D$, where D is the duty cycle. For example, with 50% duty cycle, at least 200 traces shall be averaged. (If a specific emission is demonstrated to be continuous—i.e., 100% duty cycle—then rather than turning ON and OFF with the transmit cycle, at least 100 traces shall be averaged.)

g) If tests are performed with the EUT transmitting at a duty cycle less than 98%, then a correction factor shall be added to the measurement results prior to comparing with the emission limit, to compute the emission level that would have been measured had the test been performed at 100% duty cycle. The correction factor is computed as follows:

1) If power averaging (rms) mode was used in the preceding step e), then the correction factor is $[10 \log (1 / D)]$, where D is the duty cycle. For example, if the transmit duty cycle was 50%, then 3 dB shall be added to the measured emission levels.

2) If linear voltage averaging mode was used in the preceding step e), then the correction factor is $[20 \log (1 / D)]$, where D is the duty cycle. For example, if the transmit duty cycle was 50%, then 6 dB shall be added to the measured emission levels.

3) If a specific emission is demonstrated to be continuous (100% duty cycle) rather than turning ON and OFF with the transmit cycle, then no duty cycle correction is required for that emission.

Reduce the video bandwidth until no significant variations in the displayed signal are observed in subsequent traces, provided the video bandwidth is no less than 1 Hz. For regulatory requirements that specify averaging only over the transmit duration (e.g., digital transmission system [DTS] and Unlicensed National Information Infrastructure [U-NII]), the video bandwidth shall be greater than $[1 / (\text{minimum transmitter on time})]$ and no less than 1 Hz.

The field strength of spurious emission was measured in the following position: EUT stand-up position (Z axis), lie-down position (X, Y axis). The worst emission was found in stand-up position (Z axis) and the loop antenna is vertical, others antenna are vertical and horizontal.

The test is in transmitting mode.

9KHz~30MHz

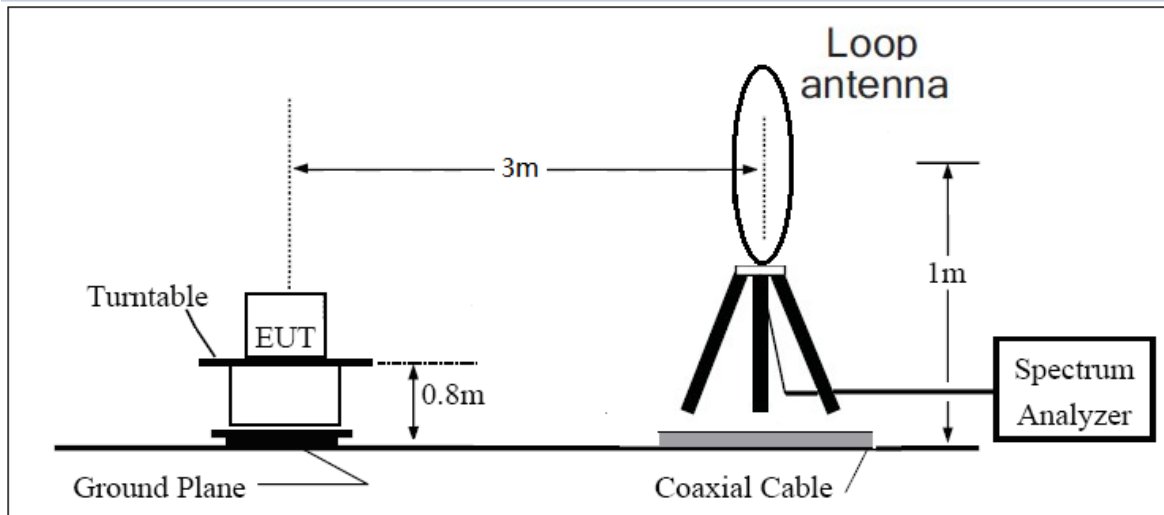

30MHz~~~ 1GHz

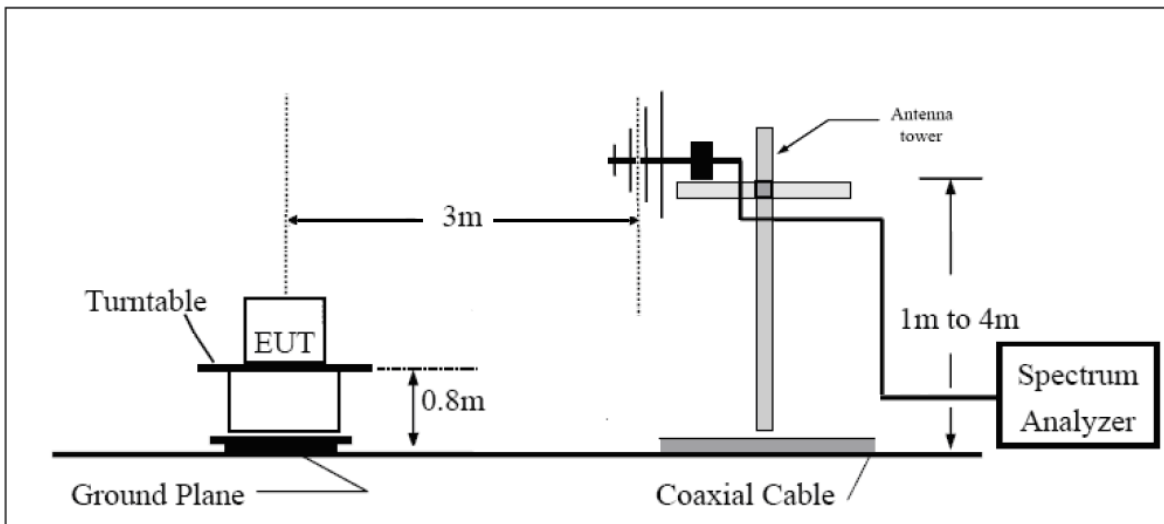

Above 1GHz

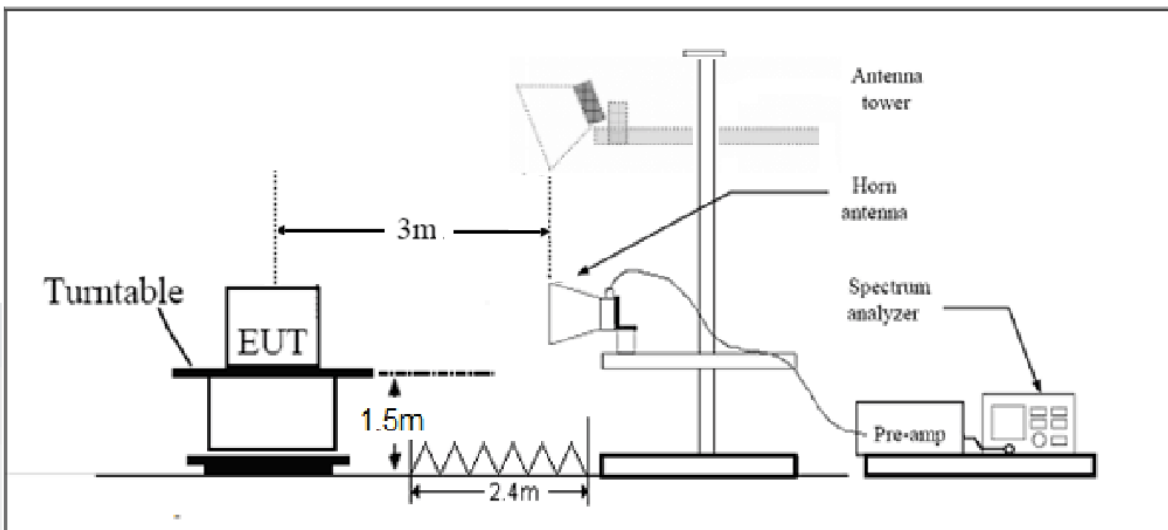

Note: Area side:2.4mX3.6m

Limits

- (1) For transmitters operating in the 5725-5850 MHz band: All emissions shall be limited to a level of -27 dBm/MHz at 75 MHz or more above or below the band edge increasing linearly to 10 dBm/MHz at 25 MHz above or below the band edge, and from 25 MHz above or below the band edge increasing linearly to a level of 15.6 dBm/MHz at 5 MHz above or below the band edge, and from 5 MHz above or below the band edge increasing linearly to a level of 27 dBm/MHz at the band edge.

Measurement Uncertainty

The assessed measurement uncertainty to ensure 95% confidence level for the normal distribution is with the coverage factor $k = 1.96$.

| Frequency | Uncertainty |
|---------------|-------------|
| 9KHz-30MHz | 3.55 dB |
| 30MHz-200MHz | 4.02 dB |
| 200MHz-1GHz | 3.28 dB |
| 1GHz-18G | 3.70 dB |
| 18GHz-26.5GHz | 5.78 dB |
| 26.5G-40GHz | 5.82 dB |

Test Results:

The signal beyond the limit is carrier.

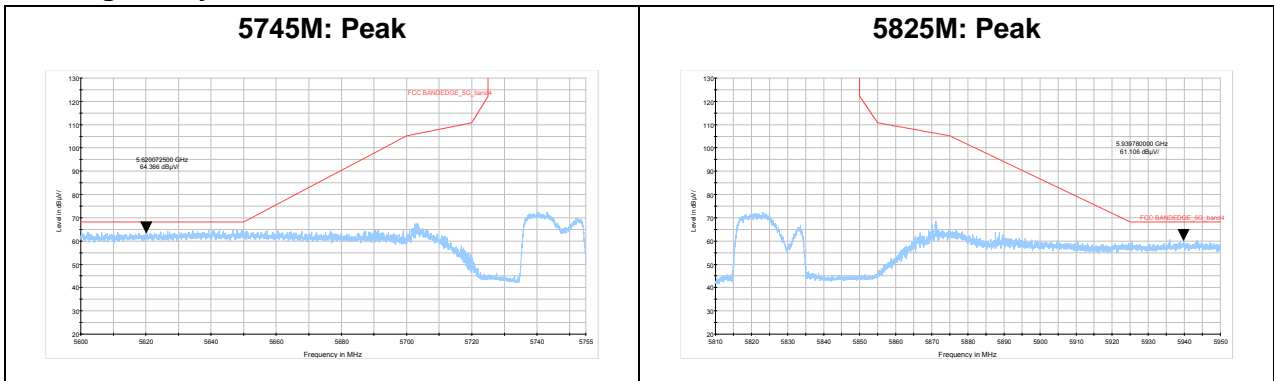

Result of RE**Test result**

Sweep the whole frequency band through the range from 9kHz to the 10th harmonic of the carrier, the Emissions in the frequency band 9kHz-30MHz and 26.5GHz-40GHz are more than 20dB below the limit are not reported.

During the test, the Radiates Emission from 30MHz to 1GHz was performed in all modes with all channels, **5745M** are selected as the worst condition. The test data of the worst-case condition was recorded in this report.

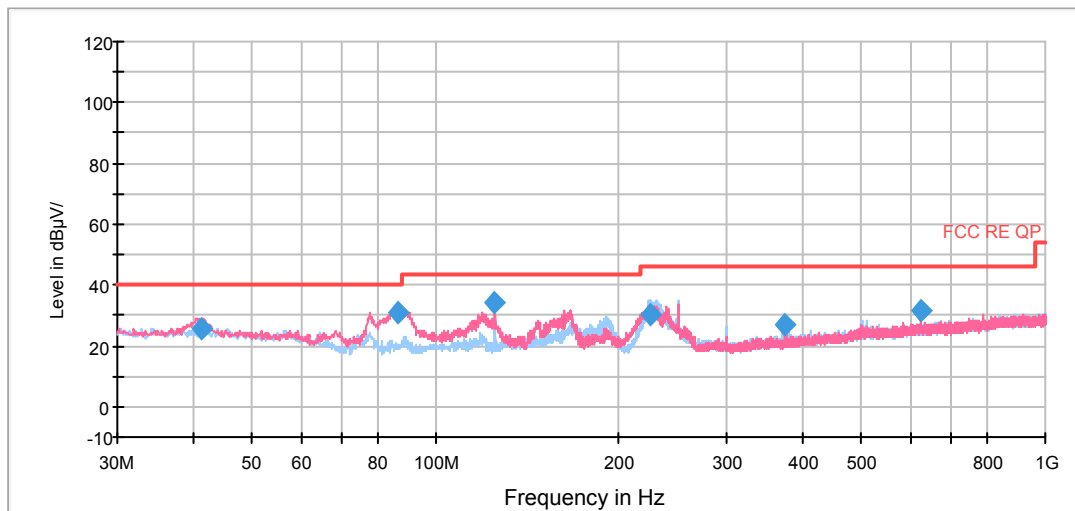
Continuous TX mode:

Radiates Emission from 30MHz to 1GHz

| Frequency (MHz) | Quasi-Peak (dBuV/m) | Height (cm) | Polarization | Azimuth (deg) | Correct Factor (dB) | Margin (dB) | Limit (dBuV/m) |
|-----------------|---------------------|-------------|--------------|---------------|---------------------|-------------|----------------|
| 41.108750 | 25.9 | 114.0 | V | 28.0 | -13.1 | 14.1 | 40.0 |
| 86.901250 | 30.8 | 100.0 | V | 6.0 | -19.2 | 9.2 | 40.0 |
| 125.018750 | 34.1 | 100.0 | V | 259.0 | -19.9 | 9.4 | 43.5 |
| 224.886250 | 30.5 | 125.0 | H | 292.0 | -18.0 | 15.5 | 46.0 |
| 374.996250 | 27.0 | 100.0 | H | 64.0 | -14.9 | 19.0 | 46.0 |
| 625.015000 | 31.5 | 100.0 | V | 228.0 | -9.3 | 14.5 | 46.0 |

Remark: 1. Correction Factor = Antenna factor+ Insertion loss(cable loss+amplifier gain)

2. Margin = Limit – Quasi-Peak

5745M

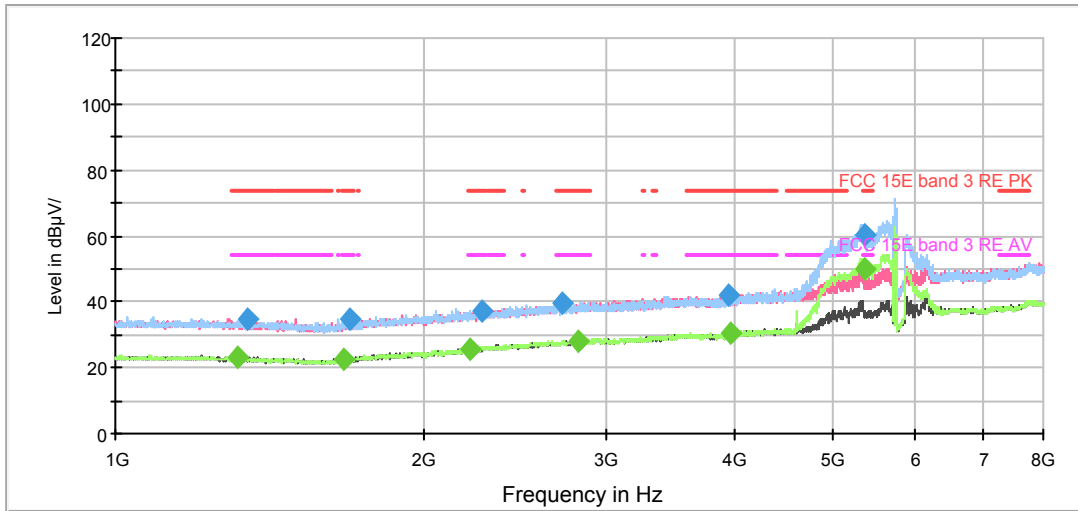

Note: The signal beyond the limit is carrier.
Radiates Emission from 1GHz to 8GHz

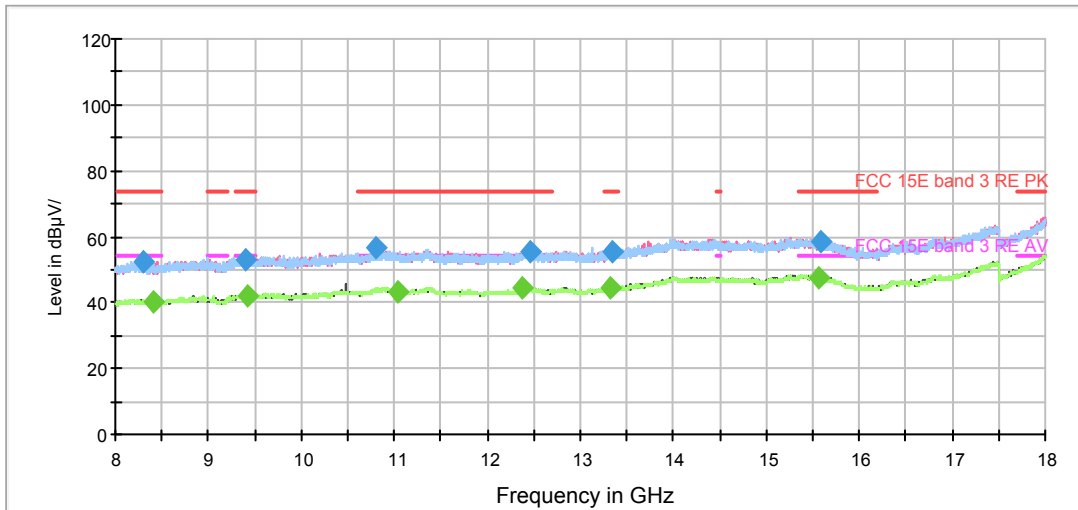

Radiates Emission from 8GHz to 18GHz

| Frequency (MHz) | Peak (dBuV/m) | Height (cm) | Polarization | Azimuth (deg) | Correct Factor (dB) | Margin (dB) | Limit (dBuV/m) |
|-----------------|---------------|-------------|--------------|---------------|---------------------|-------------|----------------|
| 1342.125000 | 34.7 | 100.0 | H | 20.0 | -10.9 | 39.3 | 74.0 |
| 1687.750000 | 34.6 | 100.0 | H | 14.0 | -9.6 | 39.4 | 74.0 |
| 2273.125000 | 37.3 | 200.0 | H | 118.0 | -7.3 | 36.7 | 74.0 |
| 2717.625000 | 39.5 | 200.0 | H | 0.0 | -5.9 | 34.5 | 74.0 |
| 3945.250000 | 41.8 | 100.0 | H | 300.0 | -2.9 | 32.2 | 74.0 |
| 5364.500000 | 60.5 | 200.0 | H | 357.0 | 0.8 | 13.5 | 74.0 |

Remark: 1. Correction Factor = Antenna factor+ Insertion loss (cable loss + amplifier gain)

| Frequency (MHz) | Average (dBuV/m) | Height (cm) | Polarization | Azimuth (deg) | Correct Factor (dB) | Margin (dB) | Limit (dBuV/m) |
|-----------------|------------------|-------------|--------------|---------------|---------------------|-------------|----------------|
| 1316.750000 | 22.9 | 100.0 | H | 0.0 | -10.9 | 31.1 | 54.0 |
| 1670.250000 | 22.5 | 200.0 | V | 37.0 | -9.7 | 31.5 | 54.0 |
| 2216.250000 | 25.7 | 100.0 | V | 0.0 | -7.7 | 28.3 | 54.0 |
| 2827.000000 | 28.1 | 100.0 | H | 20.0 | -5.6 | 25.9 | 54.0 |
| 3975.875000 | 30.5 | 200.0 | V | 0.0 | -2.9 | 23.5 | 54.0 |
| 5362.750000 | 49.8 | 200.0 | H | 357.0 | 0.8 | 4.2 | 54.0 |

Remark: 1. Correction Factor = Antenna factor+ Insertion loss (cable loss + amplifier gain)

5785M

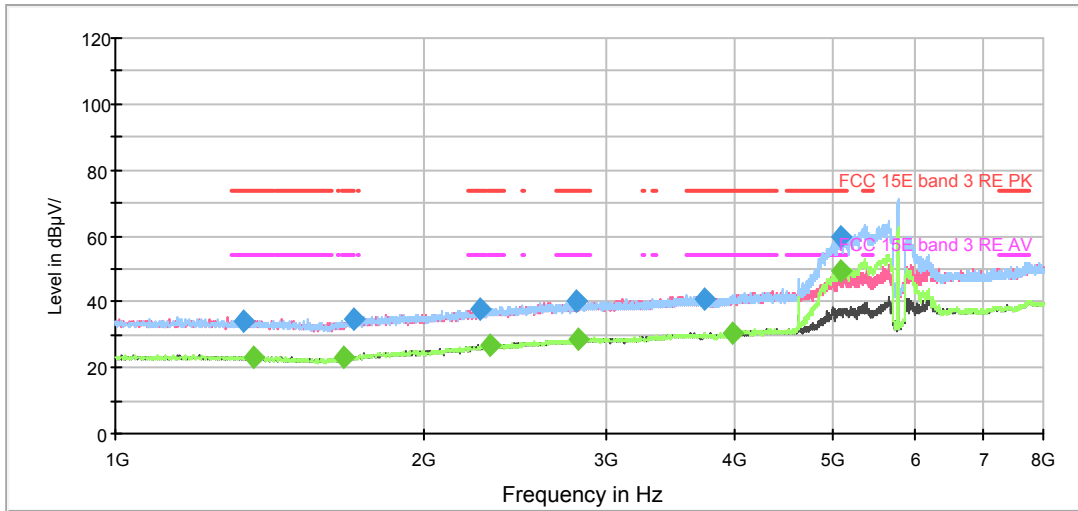

Note: The signal beyond the limit is carrier.
Radiates Emission from 1GHz to 8GHz

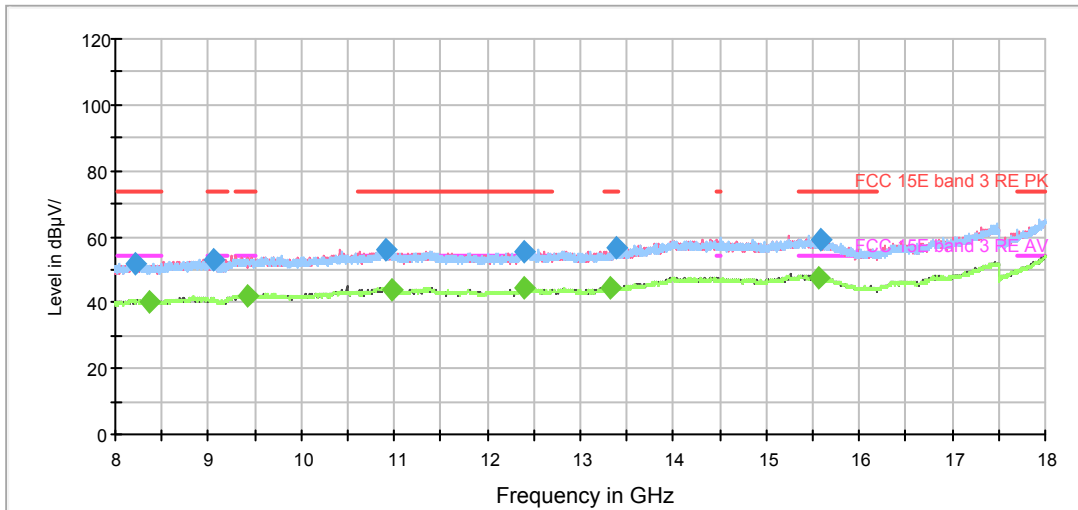

Radiates Emission from 8GHz to 18GHz

| Frequency (MHz) | Peak (dBuV/m) | Height (cm) | Polarization | Azimuth (deg) | Correct Factor (dB) | Margin (dB) | Limit (dBuV/m) |
|-----------------|---------------|-------------|--------------|---------------|---------------------|-------------|----------------|
| 1335.125000 | 34.0 | 200.0 | V | 0.0 | -10.9 | 40.0 | 74.0 |
| 1703.500000 | 34.9 | 100.0 | H | 23.0 | -9.6 | 39.1 | 74.0 |
| 2260.000000 | 37.8 | 100.0 | H | 4.0 | -7.5 | 36.2 | 74.0 |
| 2812.125000 | 40.2 | 200.0 | V | 8.0 | -5.7 | 33.8 | 74.0 |
| 3737.875000 | 41.1 | 100.0 | V | 354.0 | -3.4 | 32.9 | 74.0 |
| 5076.625000 | 60.0 | 200.0 | H | 358.0 | -0.2 | 14.0 | 74.0 |

Remark: 1. Correction Factor = Antenna factor+ Insertion loss (cable loss + amplifier gain)

| Frequency (MHz) | Average (dBuV/m) | Height (cm) | Polarization | Azimuth (deg) | Correct Factor (dB) | Margin (dB) | Limit (dBuV/m) |
|-----------------|------------------|-------------|--------------|---------------|---------------------|-------------|----------------|
| 1364.875000 | 23.4 | 100.0 | H | 132.0 | -10.8 | 30.6 | 54.0 |
| 1672.000000 | 22.8 | 100.0 | H | 4.0 | -9.7 | 31.2 | 54.0 |
| 2314.250000 | 26.8 | 200.0 | H | 315.0 | -7.2 | 27.2 | 54.0 |
| 2825.250000 | 28.4 | 100.0 | H | 132.0 | -5.6 | 25.6 | 54.0 |
| 3995.125000 | 30.5 | 200.0 | V | 0.0 | -2.8 | 23.5 | 54.0 |
| 5078.375000 | 49.4 | 200.0 | H | 356.0 | -0.2 | 4.6 | 54.0 |

Remark: 1. Correction Factor = Antenna factor+ Insertion loss (cable loss + amplifier gain)

5825M

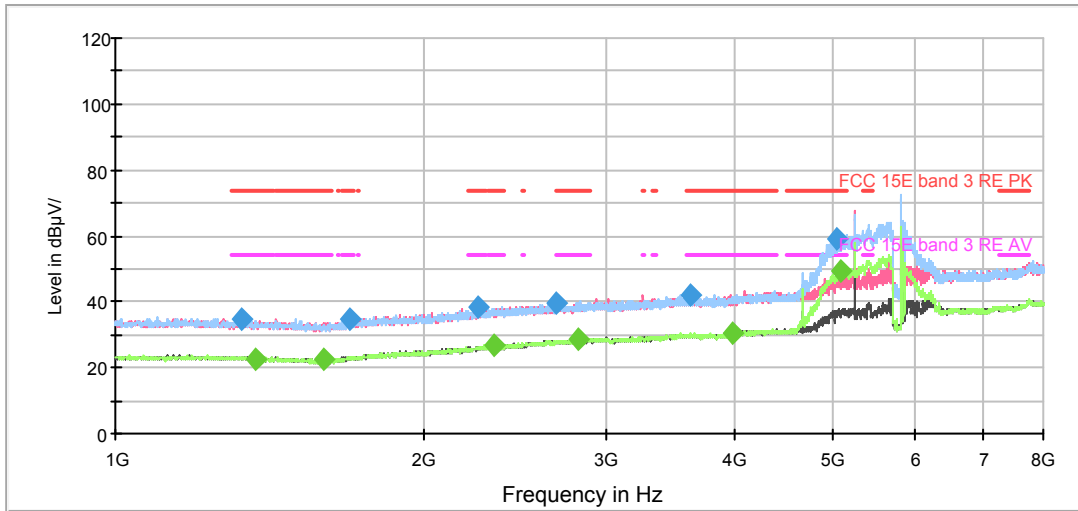

Note: The signal beyond the limit is carrier.
Radiates Emission from 1GHz to 8GHz

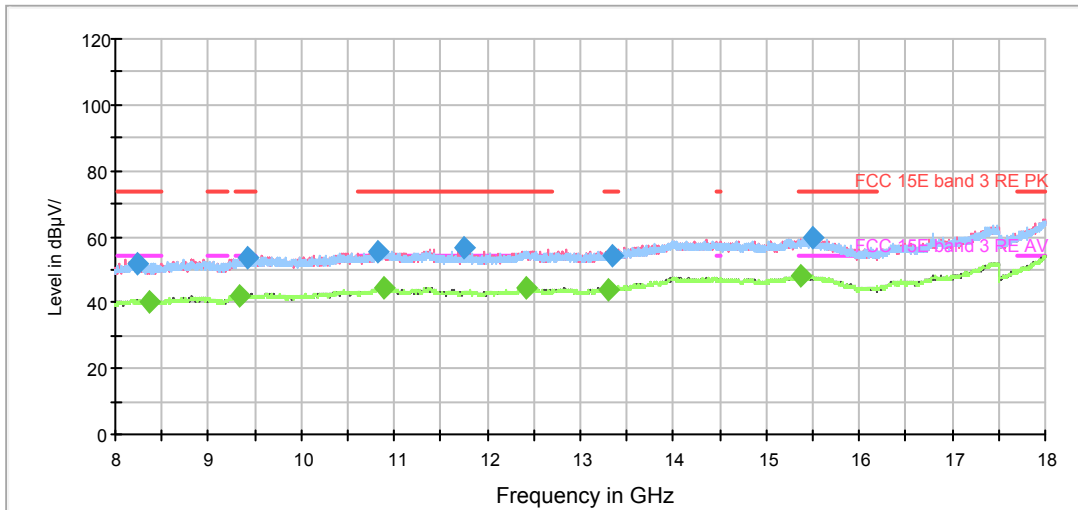

Radiates Emission from 8GHz to 18GHz

| Frequency (MHz) | Peak (dBuV/m) | Height (cm) | Polarization | Azimuth (deg) | Correct Factor (dB) | Margin (dB) | Limit (dBuV/m) |
|-----------------|---------------|-------------|--------------|---------------|---------------------|-------------|----------------|
| 1325.500000 | 34.8 | 200.0 | V | 152.0 | -10.9 | 39.2 | 74.0 |
| 1688.625000 | 34.5 | 100.0 | H | 0.0 | -9.6 | 39.5 | 74.0 |
| 2255.625000 | 38.7 | 200.0 | H | 346.0 | -7.5 | 35.3 | 74.0 |
| 2690.500000 | 39.7 | 100.0 | V | 144.0 | -6.0 | 34.3 | 74.0 |
| 3633.750000 | 42.3 | 100.0 | V | 305.0 | -3.5 | 31.7 | 74.0 |
| 5037.250000 | 59.2 | 200.0 | H | 0.0 | -0.2 | 14.8 | 74.0 |

Remark: 1. Correction Factor = Antenna factor+ Insertion loss (cable loss + amplifier gain)

| Frequency (MHz) | Average (dBuV/m) | Height (cm) | Polarization | Azimuth (deg) | Correct Factor (dB) | Margin (dB) | Limit (dBuV/m) |
|-----------------|------------------|-------------|--------------|---------------|---------------------|-------------|----------------|
| 1371.875000 | 22.8 | 200.0 | V | 22.0 | -10.8 | 31.2 | 54.0 |
| 1596.750000 | 22.4 | 200.0 | V | 46.0 | -10.0 | 31.6 | 54.0 |
| 2336.125000 | 26.7 | 200.0 | V | 110.0 | -7.0 | 27.3 | 54.0 |
| 2827.000000 | 28.5 | 200.0 | H | 0.0 | -5.6 | 25.5 | 54.0 |
| 3981.125000 | 30.4 | 200.0 | H | 0.0 | -2.8 | 23.6 | 54.0 |
| 5077.500000 | 49.6 | 200.0 | H | 355.0 | -0.2 | 4.4 | 54.0 |

Remark: 1. Correction Factor = Antenna factor+ Insertion loss (cable loss + amplifier gain)

6. Main Test Instruments

| Name | Manufacturer | Type | Serial Number | Calibration Date | Expiration Time |
|--|--------------|-----------|---------------|------------------|-----------------|
| Spectrum Analyzer | R&S | FSV40 | 15195-01-00 | 2020-05-17 | 2021-05-16 |
| Spectrum Analyzer | Key sight | N9010A | MY50210259 | 2020-12-14 | 2021-12-13 |
| TRILOG Broadband Antenna | SCHWARZBECK | VULB 9163 | 391 | 2019-12-16 | 2021-12-15 |
| Horn Antenna | R&S | HF907 | 102723 | 2018-08-11 | 2021-08-10 |
| Wideband radio communication tester | R&S | CMW500 | 150415 | 2020-05-18 | 2021-05-17 |
| Signal analyzer | R&S | FSQ 26 | 101132 | 2020-05-18 | 2021-05-17 |
| Baseband signal generator and fading simulator | R&S | AMU 200A | 100577 | 2020-05-18 | 2021-05-17 |
| Vector signal generator | R&S | SMU 200A | 104652 | 2020-05-18 | 2021-05-17 |
| Signal generator | R&S | SMF 100A | 102235 | 2020-05-18 | 2021-05-17 |
| MOB COMMS DC SUPPLY | Keysight | 66319D | MY43004105 | 2020-05-18 | 2021-05-17 |
| Climate Chamber | ESPEC | SU-242 | 93000506 | 2020-12-16 | 2023-12-15 |
| Software | R&S | EMC32 | 9.26.0 | / | / |

*****END OF REPORT *****