



# RF TEST REPORT

**Applicant** Shanghai Smawave  
Technology Co., Ltd

**FCC ID** 2AU8HMGL6213A

**Product** LTE MODULE

**Brand** Smawave

**Model** MGL6213A

**Report No.** R2001A0004-R1V1

**Issue Date** March 17, 2020

TA Technology (Shanghai) Co., Ltd. tested the above equipment in accordance with the requirements in **FCC CFR47 Part 15E (2019)**. The test results show that the equipment tested is capable of demonstrating compliance with the requirements as documented in this report.

Performed by: Peng Tao

Approved by: Kai Xu

---

## TA Technology (Shanghai) Co., Ltd.

No.145, Jintang Rd, Tangzhen Industry Park, Pudong Shanghai, China

TEL: +86-021-50791141/2/3

FAX: +86-021-50791141/2/3-8000



## TABLE OF CONTENT

1. Test Laboratory .....	4
1.1. Notes of the test report.....	4
1.2. Test facility .....	4
1.3. Testing Location.....	4
2. General Description of Equipment under Test.....	5
2.1. Applicant and Manufacturer Information.....	5
2.2. General information.....	5
3. Applied Standards .....	6
4. Test Configuration .....	7
5. Test Case Results .....	8
5.1. Occupied Bandwidth .....	8
5.2. Average Power Output –Conducted.....	12
5.3. Frequency Stability.....	15
5.4. Power Spectral Density.....	18
5.5. Unwanted Emission .....	21
5.6. Conducted Emission .....	33
6. Main Test Instruments.....	36



## Summary of measurement results

Number	Test Case	Clause in FCC rules	Verdict
1	Average conducted output power	15.407(a)	PASS
2	Occupied bandwidth	15.407(e)	PASS
3	Frequency stability	15.407(g)	PASS
4	Power spectral density	15.407(a)	PASS
5	Unwanted Emissions	15.407(b)	PASS
6	Conducted Emissions	15.207	PASS
Date of Testing: January 2, 2020~ March 5, 2020			
Note: All indications of Pass/Fail in this report are opinions expressed by TA Technology (Shanghai) Co., Ltd. based on interpretations and/or observations of test results. Measurement Uncertainties were not taken into account and are published for informational purposes only.			

**Note: This revised report (Report No.: R2001A0004-R1V1) supersedes and replaces the previously issued report (Report No.: R2001A0004-R1). Please discard or destroy the previously issued report and dispose of it accordingly.**



## 1. Test Laboratory

### 1.1. Notes of the test report

This report shall not be reproduced in full or partial, without the written approval of **TA technology (shanghai) co., Ltd.** The results documented in this report apply only to the tested sample, under the conditions and modes of operation as described herein. Measurement Uncertainties were not taken into account and are published for informational purposes only. This report is written to support regulatory compliance of the applicable standards stated above.

### 1.2. Test facility

#### **FCC (Designation number: CN1179, Test Firm Registration Number: 446626)**

TA Technology (Shanghai) Co., Ltd. has been listed on the US Federal Communications Commission list of test facilities recognized to perform electromagnetic emissions measurements.

#### **A2LA (Certificate Number: 3857.01)**

TA Technology (Shanghai) Co., Ltd. has been listed by American Association for Laboratory Accreditation to perform electromagnetic emission measurement.

### 1.3. Testing Location

Company: TA Technology (Shanghai) Co., Ltd.  
Address: No.145, Jintang Rd, Tangzhen Industry Park, Pudong  
City: Shanghai  
Post code: 201201  
Country: P. R. China  
Contact: Xu Kai  
Telephone: +86-021-50791141/2/3  
Fax: +86-021-50791141/2/3-8000  
Website: <http://www.ta-shanghai.com>  
E-mail: [xukai@ta-shanghai.com](mailto:xukai@ta-shanghai.com)

## 2. General Description of Equipment under Test

### 2.1. Applicant and Manufacturer Information

<b>Applicant</b>	Shanghai Smawave Technology Co. ,Ltd
<b>Applicant address</b>	3/F, Building 8, 1001 North Qinzhou Road, Xuhui District, Shanghai, China
<b>Manufacturer</b>	Shanghai Smawave Technology Co. ,Ltd
<b>Manufacturer address</b>	3/F, Building 8, 1001 North Qinzhou Road, Xuhui District, Shanghai, China

### 2.2. General information

EUT Description	
Model	MGL6213A
SN	1#
Hardware Version	V1.0
Software Version	MG12-AU_0.3.3.1_V2.6
Power Supply	External Power Supply
Antenna Type	The EUT don't have standard Antenna, The Antenna used for testing in this report is the after-market accessory (Dipole Antenna)
Antenna Gain	3.18 dBi
Modulation Type	(LTE)QPSK 16QAM;
Max. Conducted Power	22.91dBm
Operating Frequency Range(s)	5725-5850MHz
Operating temperature range:	-40 ° C to 70° C
Operating voltage range:	3.15 V to 4.2V
State DC voltage:	3.3V
Note:1. The EUT is sent from the applicant to TA and the information of the EUT is declared by the applicant.	



### 3. Applied Standards

According to the specifications of the manufacturer, it must comply with the requirements of the following standards:

**Test standards:**

**FCC CFR47 Part 15E (2019)** Unlicensed National Information Infrastructure Devices

**ANSI C63.10 (2013)**

**Reference standard:**

**KDB 789033 D02 General UNII Test Procedures New Rules v02r01**



## 4. Test Configuration

### Test Mode

The EUT has been associated with peripherals and configuration operated in a manner tended to maximize its emission characteristics in a typical application.

The radiated emission was measured in the following position: EUT stand-up position (Z axis), lie-down position (X, Y axis). The worst emission was found in lie-down position (X axis) and the worst case was recorded.

## 5. Test Case Results

### 5.1. Occupied Bandwidth

#### Ambient condition

Temperature	Relative humidity	Pressure
23°C ~25°C	45%~50%	101.5kPa

#### Method of Measurement

The EUT was connected to the spectrum analyzer through an external attenuator (20dB) and a known loss cable.

Set RBW = 100 kHz, VBW  $\geq 3 \times$  RBW, measure the maximum width of the emission that is constrained by the frequencies associated with the two outermost amplitude points (upper and lower frequencies) that are attenuated by 6 dB relative to the maximum level measured in the fundamental emission.

Note: The automatic bandwidth measurement capability of a spectrum analyzer or EMI receiver may be employed if it implements the functionality described above.

Use the 99 % power bandwidth function of the instrument

#### Test Setup

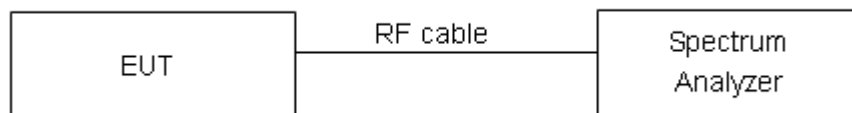

#### Limits

Rule FCC Part §15.407(e)

Within the 5.725-5.85 GHz band, the minimum 6 dB bandwidth of U-NII devices shall be at least 500 kHz.

#### Measurement Uncertainty

The assessed measurement uncertainty to ensure 95% confidence level for the normal distribution is with the coverage factor  $k = 2$ ,  $U = 936$  Hz.



**Test Results:**

Modulation	Channel	99% bandwidth (MHz)	Minimum 6 dB bandwidth (MHz)	Limit (kHz)	Conclusion
QPSK	52740	17.821	17.92	500	PASS
	53140	17.790	17.96	500	PASS
	53540	17.777	17.91	500	PASS
16QAM	52740	17.705	17.91	500	PASS
	53140	17.765	17.90	500	PASS
	53540	17.783	17.60	500	PASS



99% bandwidth

QPSK, CH52740

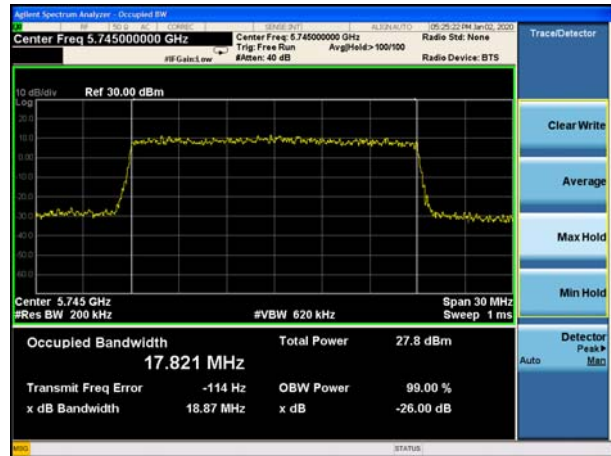

16QAM, CH52740

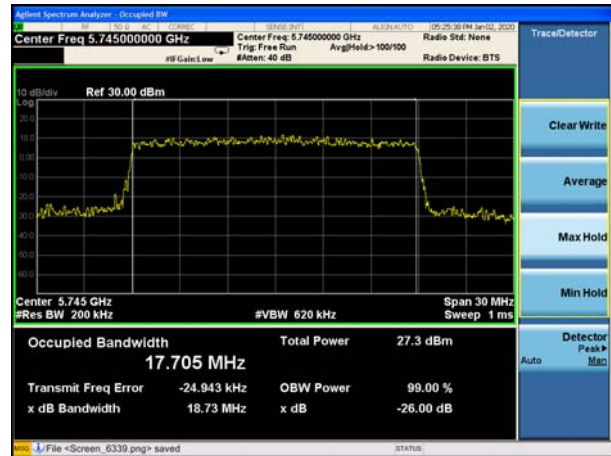

QPSK, CH53140

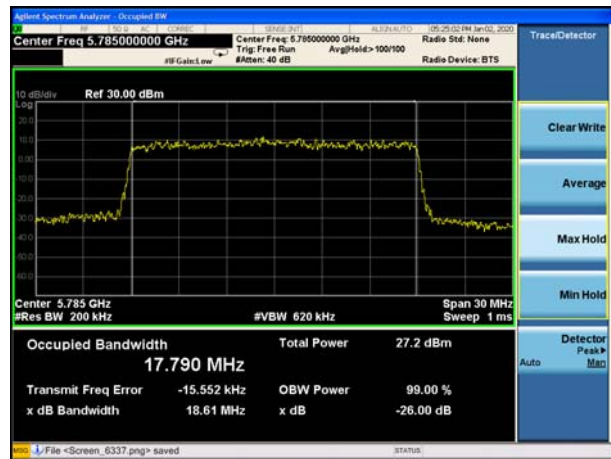

16QAM, CH53140

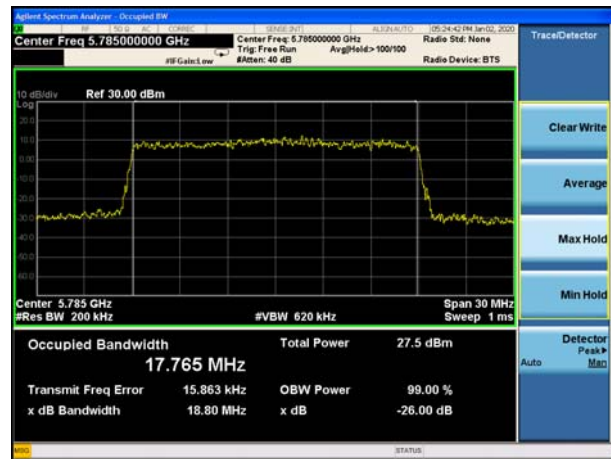

QPSK, CH53540

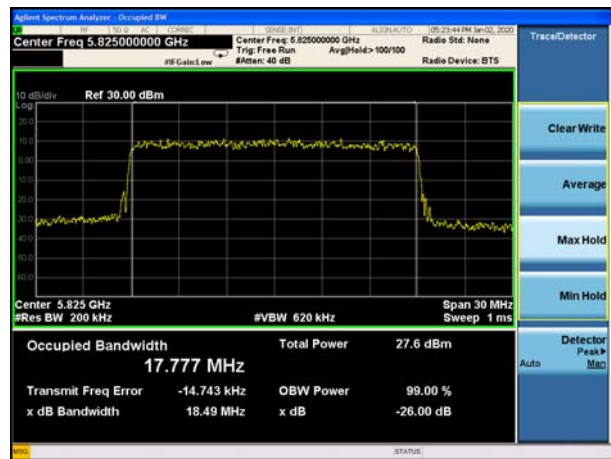

16QAM, CH53540

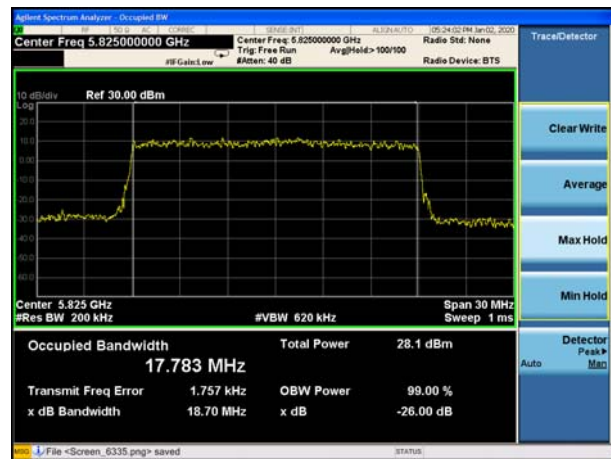



### Minimum 6 dB bandwidth

#### QPSK, CH52740

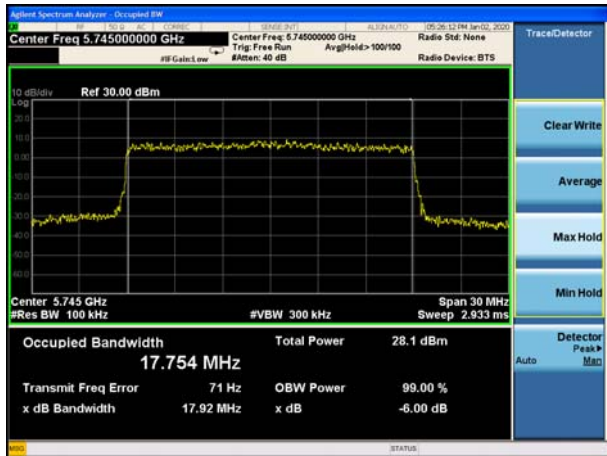

#### 16QAM, CH52740

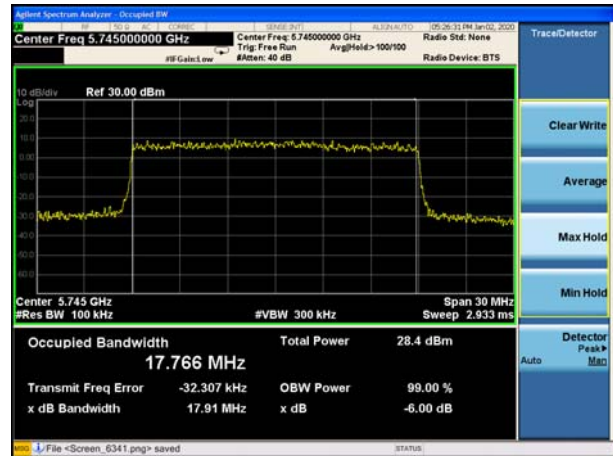

#### QPSK, CH53140

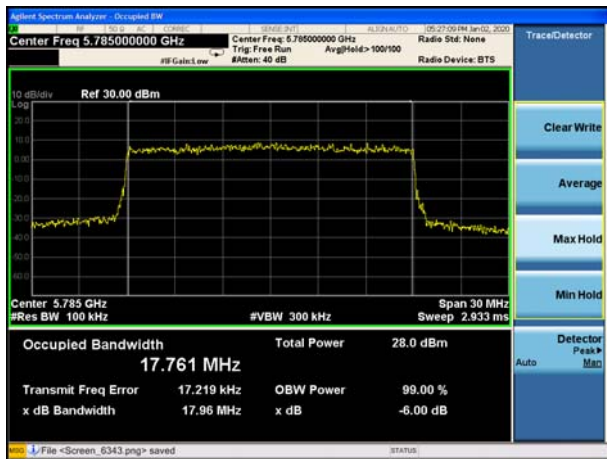

#### 16QAM, CH53140

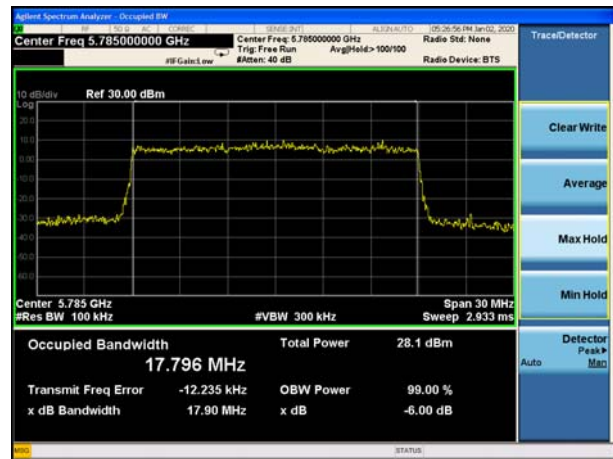

#### QPSK, CH53540

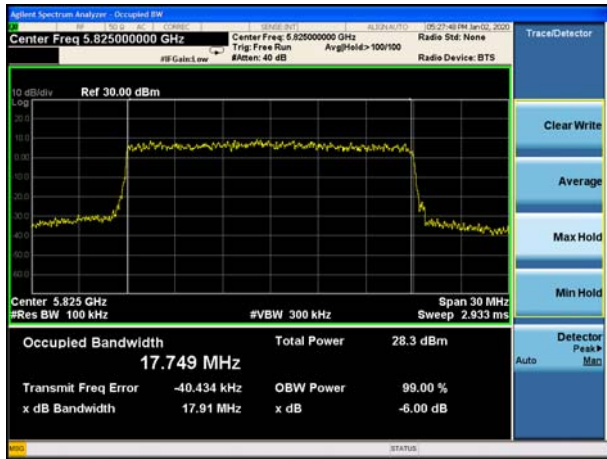

#### 16QAM, CH53540

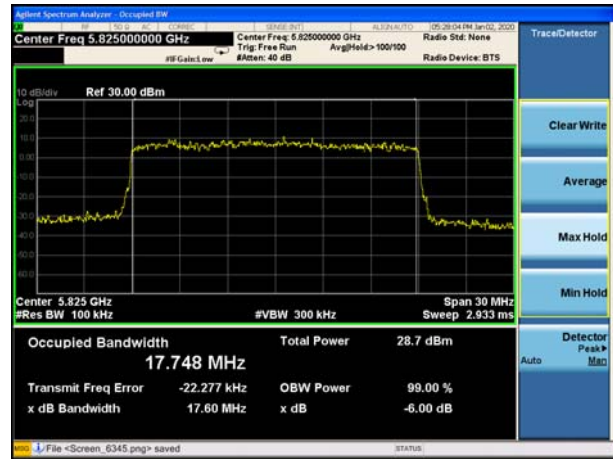

## 5.2. Average Power Output –Conducted

### Ambient condition

Temperature	Relative humidity	Pressure
23°C ~25°C	45%~50%	101.5kPa

### Methods of Measurement

During the process of the testing, The EUT was connected to the average power meter through an external attenuator and a known loss cable. The EUT is max power transmission with proper modulation. We use Maximum average Conducted Output Power Level Method in KDB789033 for this test

### Test Setup

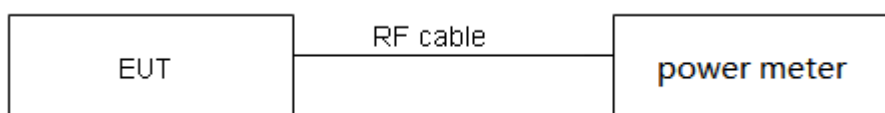

### Limits

Rule FCC Part 15.407(a)(1)(2)(3)

(1)For the band 5.725-5.85 GHz, the maximum conducted output power over the frequency band of operation shall not exceed 1 W. In addition, the maximum power spectral density shall not exceed 30 dBm in any 500-kHz band. If transmitting antennas of directional gain greater than 6 dBi are used, both the maximum conducted output power and the maximum power spectral density shall be reduced by the amount in dB that the directional gain of the antenna exceeds 6 dBi.

### Measurement Uncertainty

The assessed measurement uncertainty to ensure 95% confidence level for the normal distribution is with the coverage factor  $k = 2$ ,  $U = 0.44$  dB.



## Test Results

Bandwidth	Modulation	Channel	RB Configuration	Conducted Power(dBm)
20M	QPSK	52740	1RB#0	21.68
20M	QPSK	52740	1RB#50	22.84
20M	QPSK	52740	1RB#99	22.08
20M	QPSK	52740	50RB#0	22.47
20M	QPSK	52740	50RB#25	22.65
20M	QPSK	52740	50RB#50	22.76
20M	QPSK	52740	100RB#0	22.63
20M	QPSK	53140	1RB#0	22.38
20M	QPSK	53140	1RB#50	22.74
20M	QPSK	53140	1RB#99	21.12
20M	QPSK	53140	50RB#0	22.71
20M	QPSK	53140	50RB#25	22.59
20M	QPSK	53140	50RB#50	22.26
20M	QPSK	53140	100RB#0	22.56
20M	QPSK	53540	1RB#0	21.68
20M	QPSK	53540	1RB#50	22.42
20M	QPSK	53540	1RB#99	21.59
20M	QPSK	53540	50RB#0	22.23
20M	QPSK	53540	50RB#25	22.36
20M	QPSK	53540	50RB#50	22.29
20M	QPSK	53540	100RB#0	22.32
20M	16QAM	52740	1RB#0	21.83
20M	16QAM	52740	1RB#50	22.91
20M	16QAM	52740	1RB#99	22.18
20M	16QAM	52740	50RB#0	22.43
20M	16QAM	52740	50RB#25	22.61
20M	16QAM	52740	50RB#50	22.71
20M	16QAM	52740	100RB#0	22.55
20M	16QAM	53140	1RB#0	22.54
20M	16QAM	53140	1RB#50	22.91
20M	16QAM	53140	1RB#99	21.34
20M	16QAM	53140	50RB#0	22.71
20M	16QAM	53140	50RB#25	21.79
20M	16QAM	53140	50RB#50	22.27
20M	16QAM	53140	100RB#0	22.73
20M	16QAM	53540	1RB#0	21.86



20M	16QAM	53540	1RB#50	22.59
20M	16QAM	53540	1RB#99	21.79
20M	16QAM	53540	50RB#0	22.26
20M	16QAM	53540	50RB#25	22.41
20M	16QAM	53540	50RB#50	22.32
20M	16QAM	53540	100RB#0	22.36

### 5.3. Frequency Stability

#### Ambient condition

Temperature	Relative humidity	Pressure
23°C ~25°C	45%~50%	101.5kPa

#### Method of Measurement

##### 1. Frequency stability with respect to ambient temperature

a) Supply the EUT with a nominal ac voltage or install a new or fully charged battery in the EUT. If possible, a dummy load shall be connected to the EUT because an antenna near the metallic walls of an environmental test chamber could affect the output frequency of the EUT. If the EUT is equipped with a permanently attached, adjustable-length antenna, then the EUT shall be placed in the center of the chamber with the antenna adjusted to the shortest length possible. Turn ON the EUT and tune it to one of the number of frequencies shown in 5.6.

b) Couple the unlicensed wireless device output to the measuring instrument by connecting an antenna to the measuring instrument with a suitable length of coaxial cable and placing the measuring antenna near the EUT (e.g., 15 cm away), or by connecting a dummy load to the measuring instrument, through an attenuator if necessary.

c) Adjust the location of the measurement antenna and the controls on the measurement instrument to obtain a suitable signal level (i.e., a level that will not overload the measurement instrument but is strong enough to allow measurement of the operating or fundamental frequency of the EUT).

d) Turn the EUT OFF and place it inside the environmental temperature chamber. For devices that have oscillator heaters, energize only the heater circuit.

e) Set the temperature control on the chamber to the highest specified in the regulatory requirements for the type of device and allow the oscillator heater and the chamber temperature to stabilize.

f) While maintaining a constant temperature inside the environmental chamber, turn the EUT ON and record the operating frequency at startup, and at 2 minutes, 5 minutes, and 10 minutes after the EUT is energized. Four measurements in total are made.

g) Measure the frequency at each of frequencies specified in 5.6.

h) Switch OFF the EUT but do not switch OFF the oscillator heater.

i) Lower the chamber temperature by not more than 10°C, and allow the temperature inside the chamber to stabilize.

j) Repeat step f) through step i) down to the lowest specified temperature.

##### 2. Frequency stability when varying supply voltage

Unless otherwise specified, these tests shall be made at ambient room temperature (+15°C to +25 °C). An antenna shall be connected to the antenna output terminals of the EUT if possible. If the EUT is equipped with or uses an adjustable-length antenna, then it shall be fully extended.

a) Supply the EUT with nominal voltage or install a new or fully charged battery in the EUT. Turn ON the EUT and couple its output to a frequency counter or other frequency-measuring instrument.



- b) Tune the EUT to one of the number of frequencies required in 5.6. Adjust the location of the measurement antenna and the controls on the measurement instrument to obtain a suitable signal level (i.e., a level that will not overload the measurement instrument but is strong enough to allow measurement of the operating or fundamental frequency of the EUT).
- c) Measure the frequency at each of the frequencies specified in 5.6.
- d) Repeat the above procedure at 85% and 115% of the nominal supply voltage.

**Limit**

Manufacturers of U-NII devices are responsible for ensuring frequency stability such that an emission is maintained within the band of operation under all conditions of normal operation as specified in the users manual.

**Measurement Uncertainty**

The assessed measurement uncertainty to ensure 95% confidence level for the normal distribution is with the coverage factor  $k = 2$ ,  $U = 936\text{Hz}$



**Test Results**

Voltage (V)	Temperature (°C)	Test Results			
		5785MHz			
		1min	2min	5min	10min
NV (3.3)	-40	5785.008286	5785.003137	5784.993557	5784.992131
NV (3.3)	-30	5785.007889	5785.002636	5784.985668	5784.984249
NV (3.3)	-20	5785.003334	5785.001474	5784.982243	5784.980705
NV (3.3)	-10	5784.999702	5784.991685	5784.978080	5784.979373
NV (3.3)	0	5784.990758	5784.986696	5784.972902	5784.978254
NV (3.3)	10	5784.990161	5784.984701	5784.966907	5784.971767
NV (3.3)	20	5784.984812	5784.984193	5784.958278	5784.970934
NV (3.3)	30	5784.978649	5784.982122	5784.949400	5784.963549
NV (3.3)	40	5784.996548	5784.990513	5784.973795	5784.977183
NV (3.3)	50	5784.995537	5784.982965	5784.966059	5784.972309
NV (3.3)	60	5784.995424	5784.973529	5784.963563	5784.966272
NV (3.3)	70	5784.994963	5784.963547	5784.961593	5784.959493
LV (3.15)	20	5784.985560	5784.958761	5784.955965	5784.950613
HV (4.2)	20	5784.979663	5784.952151	5784.949994	5784.950446
	MHz	-0.021351	-0.047849	-0.050600	-0.049554
	PPM	-3.690823	-8.271231	-8.746754	-8.565989

### 5.4. Power Spectral Density

#### Ambient condition

Temperature	Relative humidity	Pressure
23°C ~25°C	45%~50%	101.5kPa

#### Method of Measurement

The EUT was connected to the spectrum analyzer through an external attenuator (20dB) and a known loss cable.

Set RBW = 500 kHz, VBW =1.5MHz for the band 5.725-5.85 GHz

The conducted PSD is measured at each antenna port. The measured results at the various antenna ports are then summed mathematically.

#### Test setup

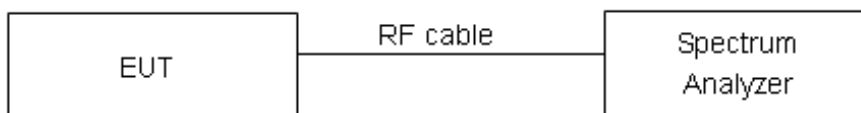

#### Limits

Rule FCC Part 15.407(a)(1)/ Part 15.407(a)(2) / Part 15.407(a)(3)

For an indoor access point operating in the band 5.15-5.25 GHz, the maximum power spectral density shall not exceed 17 dBm in any 1 megahertz band. If transmitting antennas of directional gain greater than 6 dBi are used, both the maximum conducted output power and the maximum power spectral density shall be reduced by the amount in dB that the directional gain of the antenna exceeds 6 dBi.

For the band 5.725-5.85 GHz, the maximum power spectral density shall not exceed 30 dBm in any 500-kHz band. If transmitting antennas of directional gain greater than 6 dBi are used, both the maximum conducted output power and the maximum power spectral density shall be reduced by the amount in dB that the directional gain of the antenna exceeds 6 dBi.

Frequency Bands/MHz	Limits
5725-5850	30dBm/500kHz

#### Measurement Uncertainty

The assessed measurement uncertainty to ensure 95% confidence level for the normal distribution is with the coverage factor  $k = 2$ ,  $U = 0.75\text{dB}$ .

**Test Results:**

Note: Power Spectral Density =Read Value+Duty cycle correction factor

**U-NII-3**

Modulation	Channel	Power Spectral Density (dBm/500kHz)	Limit (dBm/500kHz)	Conclusion
QPSK	52740	17.92	30	PASS
	53140	17.96	30	PASS
	53540	17.91	500	PASS
16QAM	52740	17.91	500	PASS
	53140	17.90	500	PASS
	53540	17.60	500	PASS



QPSK, CH52740

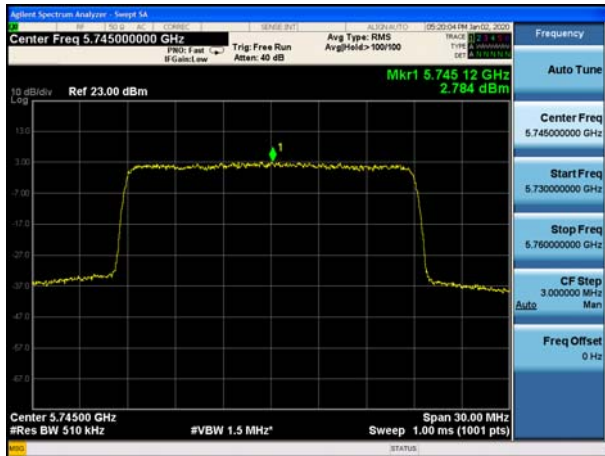

16QAM, CH52740



QPSK, CH53140

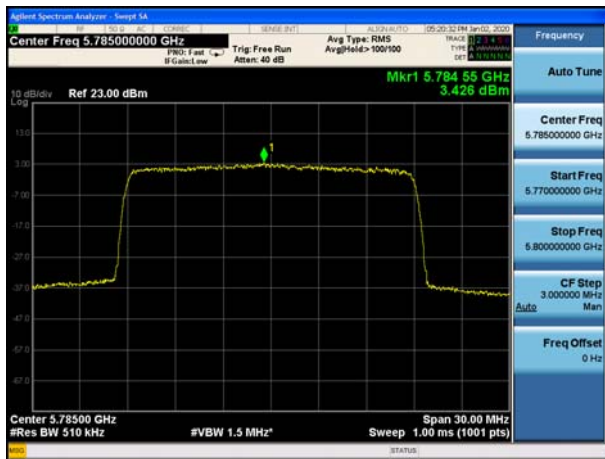

16QAM, CH53140

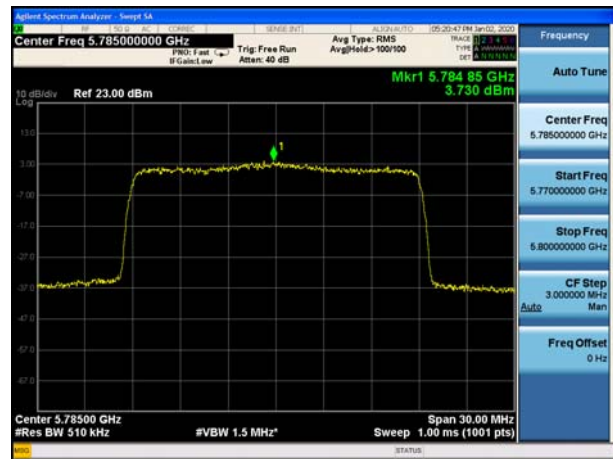

QPSK, CH53540

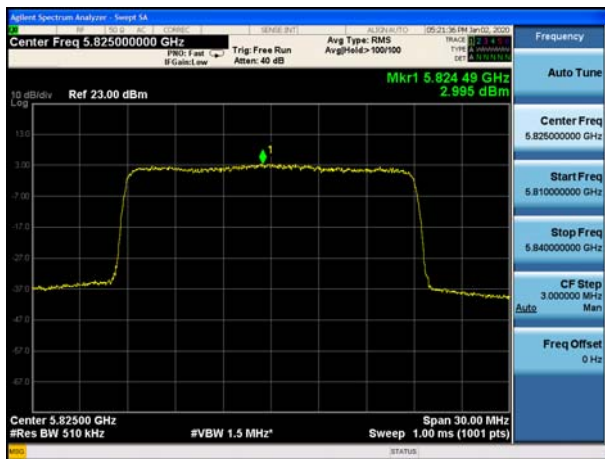

16QAM, CH53540

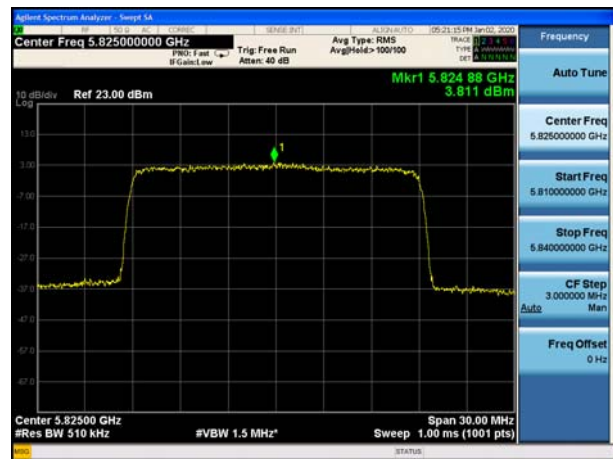

## 5.5. Unwanted Emission

### Ambient condition

Temperature	Relative humidity	Pressure
23°C ~25°C	45%~50%	101.5kPa

### Method of Measurement

The test set-up was made in accordance to the general provisions of ANSI C63.10-2013. The Equipment Under Test (EUT) was set up on a non-conductive table in the semi-anechoic chamber. The test was performed at the distance of 3 m between the EUT and the receiving antenna. The radiated emissions measurements were made in a typical installation configuration. Sweep the whole frequency band range from 9kHz to the 10th harmonic of the carrier, and the emissions less than 20 dB below the permissible value are reported.

During the test, the height of receive antenna shall be moved from 1 to 4 meters, and the antenna shall be performed under horizontal and vertical polarization. The turntable shall be rotated from 0 to 360 degrees for detecting the maximum of radiated spurious signal level. The measurements shall be repeated with orthogonal polarization of the test antenna. The data of cable loss and antenna factor has been calibrated in full testing frequency range before the testing.

Set the spectrum analyzer in the following:

Below 1GHz (detector: Peak and Quasi-Peak)

RBW=100kHz / VBW=300kHz / Sweep=AUTO

Above 1GHz (detector: Peak):

I) Peak emission levels are measured by setting the instrument as follows:

1) RBW = 1 MHz.

2) VBW  $\geq$  [3 × RBW]

3) Detector = peak.

4) Sweep time = auto.

5) Trace mode = max hold.

6) Allow sweeps to continue until the trace stabilizes. Note that if the transmission is not continuous, then the time required for the trace to stabilize will increase by a factor of approximately 1 / D, where D is the duty cycle.

II) Average emission levels are measured by setting the instrument as follows:

a) RBW = 1 MHz.

b) VBW  $\geq$  [3 × RBW].

c) Detector = RMS (power averaging), if [span / (# of points in sweep)]  $\leq$  RBW / 2. Satisfying this condition can require increasing the number of points in the sweep or reducing the span. If the condition is not satisfied, then the detector mode shall be set to peak.

d) Averaging type = power (i.e., rms) (As an alternative, the detector and averaging type may be set for linear voltage averaging. Some instruments require linear display mode to use linear voltage averaging. Log or dB averaging shall not be used.)



e) Sweep time = auto.

f) Perform a trace average of at least 100 traces if the transmission is continuous. If the transmission is not continuous, then the number of traces shall be increased by a factor of  $1 / D$ , where  $D$  is the duty cycle. For example, with 50% duty cycle, at least 200 traces shall be averaged. (If a specific emission is demonstrated to be continuous—i.e., 100% duty cycle—then rather than turning ON and OFF with the transmit cycle, at least 100 traces shall be averaged.)

g) If tests are performed with the EUT transmitting at a duty cycle less than 98%, then a correction factor shall be added to the measurement results prior to comparing with the emission limit, to compute the emission level that would have been measured had the test been performed at 100% duty cycle. The correction factor is computed as follows:

1) If power averaging (rms) mode was used in the preceding step e), then the correction factor is  $[10 \log (1 / D)]$ , where  $D$  is the duty cycle. For example, if the transmit duty cycle was 50%, then 3 dB shall be added to the measured emission levels.

2) If linear voltage averaging mode was used in the preceding step e), then the correction factor is  $[20 \log (1 / D)]$ , where  $D$  is the duty cycle. For example, if the transmit duty cycle was 50%, then 6 dB shall be added to the measured emission levels.

3) If a specific emission is demonstrated to be continuous (100% duty cycle) rather than turning ON and OFF with the transmit cycle, then no duty cycle correction is required for that emission.

Reduce the video bandwidth until no significant variations in the displayed signal are observed in subsequent traces, provided the video bandwidth is no less than 1 Hz. For regulatory requirements that specify averaging only over the transmit duration (e.g., digital transmission system [DTS] and Unlicensed National Information Infrastructure [U-NII]), the video bandwidth shall be greater than  $[1 / (\text{minimum transmitter on time})]$  and no less than 1 Hz.

The field strength of spurious emission was measured in the following position: EUT stand-up position (Z axis), lie-down position (X, Y axis). The worst emission was found in stand-up position (Z axis) and the loop antenna is vertical, others antenna are vertical and horizontal.

The test is in transmitting mode.

9KHz~~~30MHz

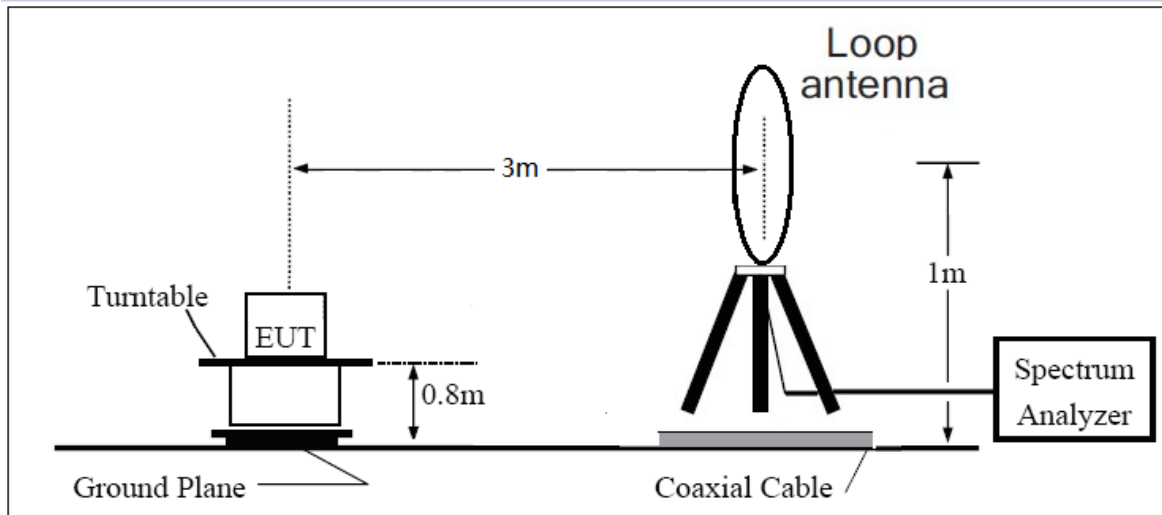

30MHz~~~ 1GHz

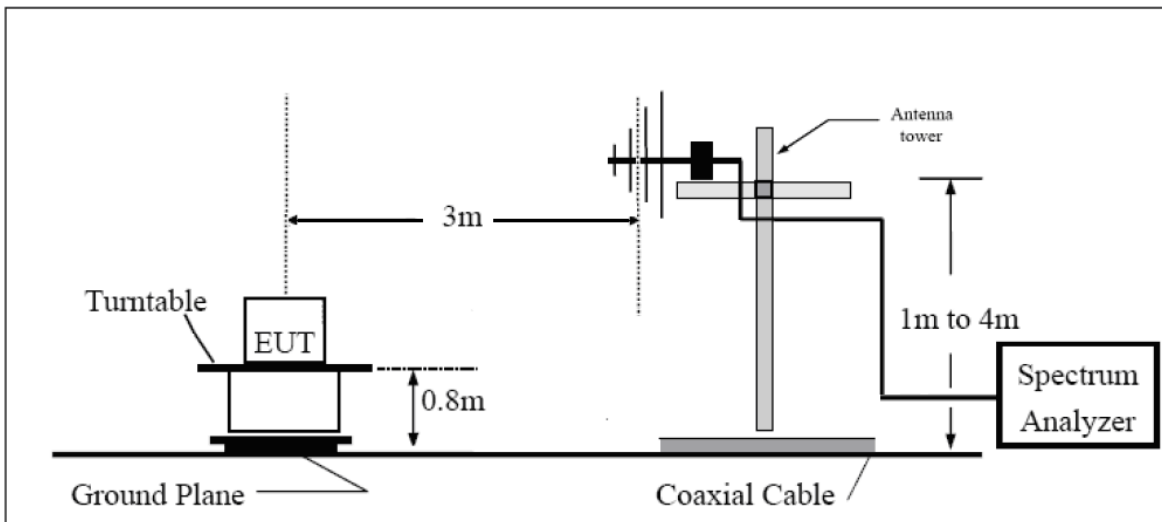

Above 1GHz

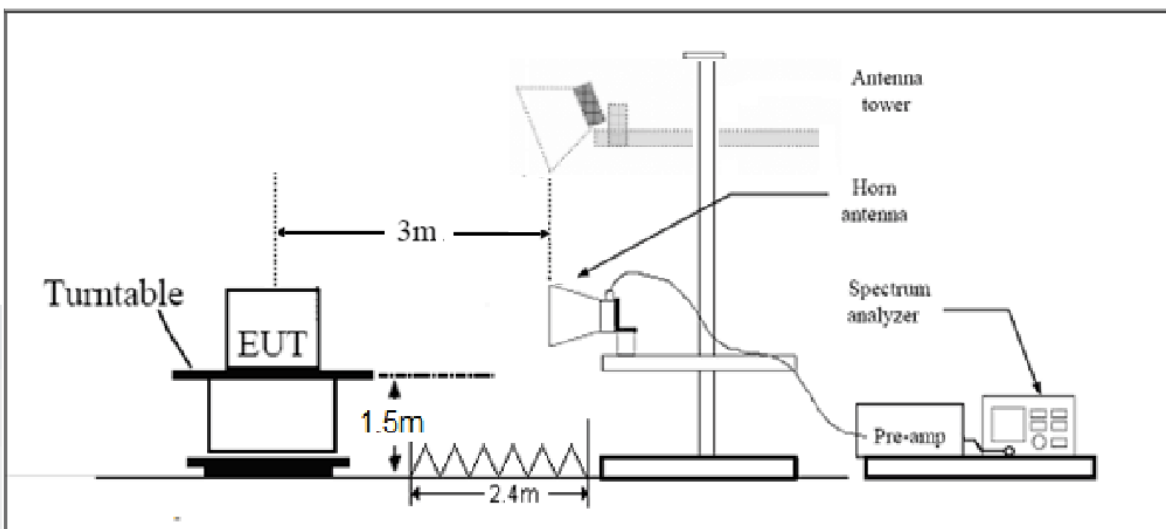

Note: Area side:2.4mX3.6m

## Limits

- (1) For transmitters operating in the 5725-5850 MHz band: All emissions shall be limited to a level of -27 dBm/MHz at 75 MHz or more above or below the band edge increasing linearly to 10 dBm/MHz at 25 MHz above or below the band edge, and from 25 MHz above or below the band edge increasing linearly to a level of 15.6 dBm/MHz at 5 MHz above or below the band edge, and from 5 MHz above or below the band edge increasing linearly to a level of 27 dBm/MHz at the band edge.

## Measurement Uncertainty

The assessed measurement uncertainty to ensure 95% confidence level for the normal distribution is with the coverage factor  $k = 1.96$ .

Frequency	Uncertainty
9KHz-30MHz	3.55 dB
30MHz-200MHz	4.02 dB
200MHz-1GHz	3.28 dB
1GHz-18G	3.70 dB
18GHz-26.5GHz	5.78 dB
26.5G-40GHz	5.82 dB





**Test Results:**

**The signal beyond the limit is carrier.**

**5745M: Peak**

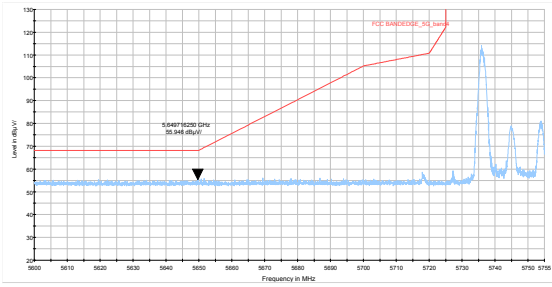

**5825M: Peak**

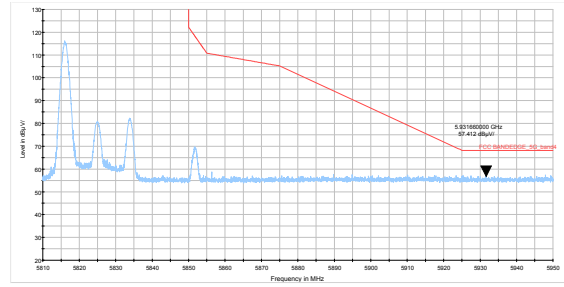

**Result of RE**

**Test result**

Sweep the whole frequency band through the range from 9kHz to the 10th harmonic of the carrier, the Emissions in the frequency band 9kHz-30MHz and 26.5GHz-40GHz are more than 20dB below the limit are not reported.

During the test, the Radiates Emission from 30MHz to 1GHz was performed in all modes with all channels, **5745M** are selected as the worst condition. The test data of the worst-case condition was recorded in this report.

**Continuous TX mode:**

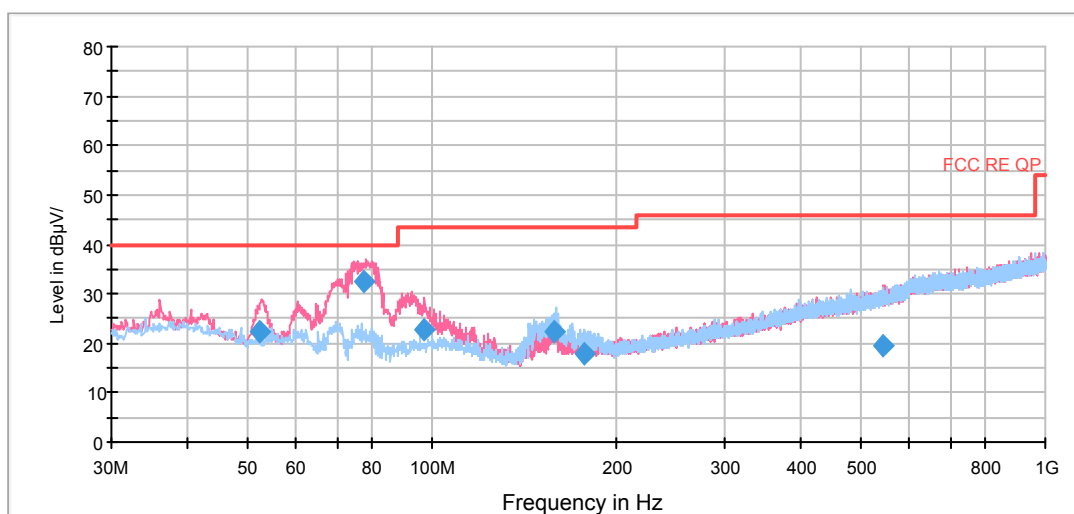

Radiates Emission from 30MHz to 1GHz

Frequency (MHz)	Quasi-Peak (dBuV/m)	Height (cm)	Polarization	Azimuth (deg)	Correct Factor (dB)	Margin (dB)	Limit (dBuV/m)
52.476250	22.2	100.0	V	132.0	13.7	17.8	40.0
77.536250	32.3	189.0	V	0.0	10.3	7.7	40.0
96.813750	22.9	100.0	V	315.0	13.1	20.6	43.5
158.651250	22.4	200.0	H	267.0	10.0	21.1	43.5
177.313750	18.0	125.0	H	80.0	10.9	25.5	43.5
543.205000	19.7	203.0	V	0.0	22.0	26.3	46.0

**Remark: 1. Correction Factor = Antenna factor+ Insertion loss(cable loss+amplifier gain)  
 2. Margin = Limit – Quasi-Peak**



5745M

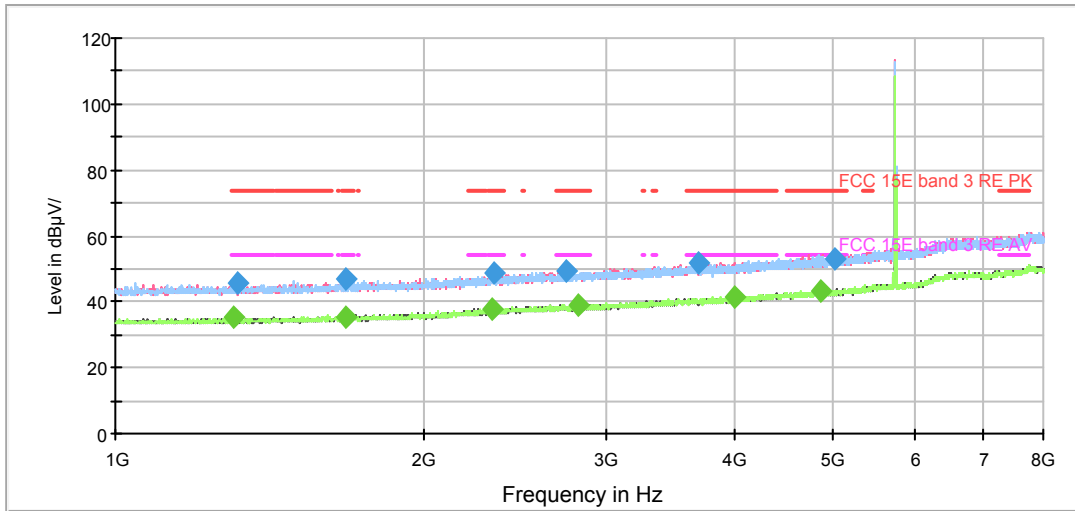

Note: The signal beyond the limit is carrier.  
Radiates Emission from 1GHz to 8GHz

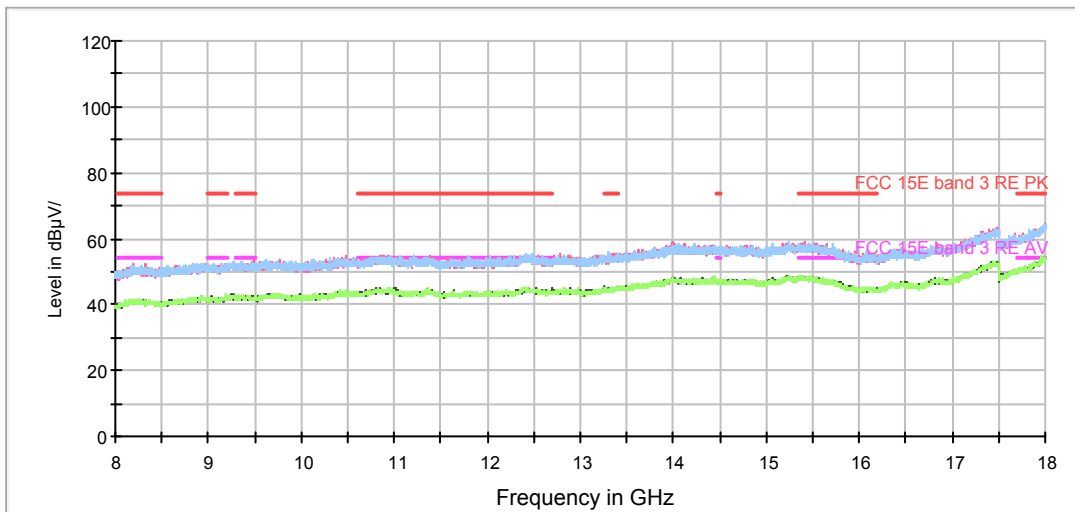

Radiates Emission from 8GHz to 18GHz



Frequency (MHz)	Peak (dBuV/m)	Height (cm)	Polarization	Azimuth (deg)	Correct Factor (dB)	Margin (dB)	Limit (dBuV/m)
1316.750000	45.5	200.0	V	107.0	-0.9	28.5	74.0
1674.625000	46.8	200.0	V	13.0	0.3	27.2	74.0
2340.500000	48.8	100.0	V	23.0	3.0	25.2	74.0
2743.000000	49.1	100.0	V	203.0	4.1	24.9	74.0
3691.500000	51.8	200.0	H	224.0	6.5	22.2	74.0
5010.125000	53.2	100.0	H	0.0	9.6	20.8	74.0

Remark: 1. Correction Factor = Antenna factor+ Insertion loss (cable loss + amplifier gain)

Frequency (MHz)	Average (dBuV/m)	Height (cm)	Polarization	Azimuth (deg)	Correct Factor (dB)	Margin (dB)	Limit (dBuV/m)
1304.500000	35.1	100.0	H	8.0	-1.0	18.9	54.0
1676.375000	35.1	200.0	V	13.0	0.3	18.9	54.0
2323.875000	37.6	100.0	V	311.0	2.9	16.4	54.0
2824.375000	39.1	100.0	V	322.0	4.4	14.9	54.0
3998.625000	41.6	200.0	V	0.0	7.3	12.4	54.0
4870.125000	43.4	200.0	H	0.0	9.5	10.6	54.0

Remark: 1. Correction Factor = Antenna factor+ Insertion loss (cable loss + amplifier gain)



5785M

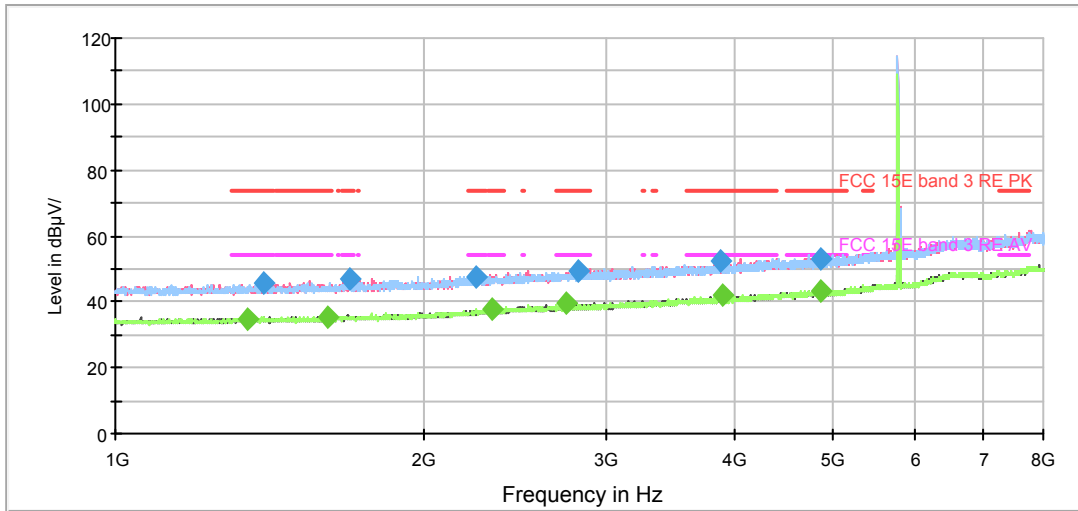

Note: The signal beyond the limit is carrier.  
Radiates Emission from 1GHz to 8GHz

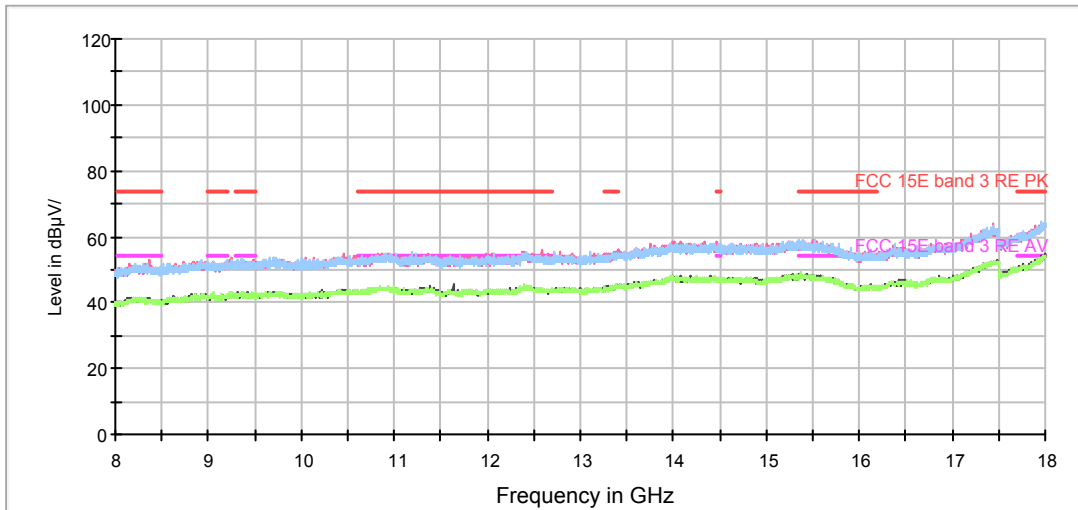

Radiates Emission from 8GHz to 18GHz



Frequency (MHz)	Peak (dBuV/m)	Height (cm)	Polarization	Azimuth (deg)	Correct Factor (dB)	Margin (dB)	Limit (dBuV/m)
1392.875000	45.5	200.0	H	61.0	-0.7	28.5	74.0
1687.750000	46.7	100.0	H	5.0	0.4	27.3	74.0
2244.250000	47.2	200.0	V	13.0	2.4	26.8	74.0
2825.250000	49.6	200.0	V	120.0	4.4	24.4	74.0
3885.750000	52.4	100.0	H	2.0	7.0	21.6	74.0
4852.625000	53.2	100.0	V	285.0	9.5	20.8	74.0

Remark: 1. Correction Factor = Antenna factor+ Insertion loss (cable loss + amplifier gain)

Frequency (MHz)	Average (dBuV/m)	Height (cm)	Polarization	Azimuth (deg)	Correct Factor (dB)	Margin (dB)	Limit (dBuV/m)
1344.750000	34.6	200.0	V	2.0	-0.9	19.4	54.0
1606.375000	35.4	200.0	V	151.0	0.0	18.6	54.0
2330.000000	37.8	200.0	H	215.0	2.9	16.2	54.0
2749.125000	39.5	200.0	V	168.0	4.1	14.5	54.0
3891.000000	42.0	100.0	H	181.0	7.1	12.0	54.0
4868.375000	43.1	100.0	V	207.0	9.5	10.9	54.0

Remark: 1. Correction Factor = Antenna factor+ Insertion loss (cable loss + amplifier gain)



5825M

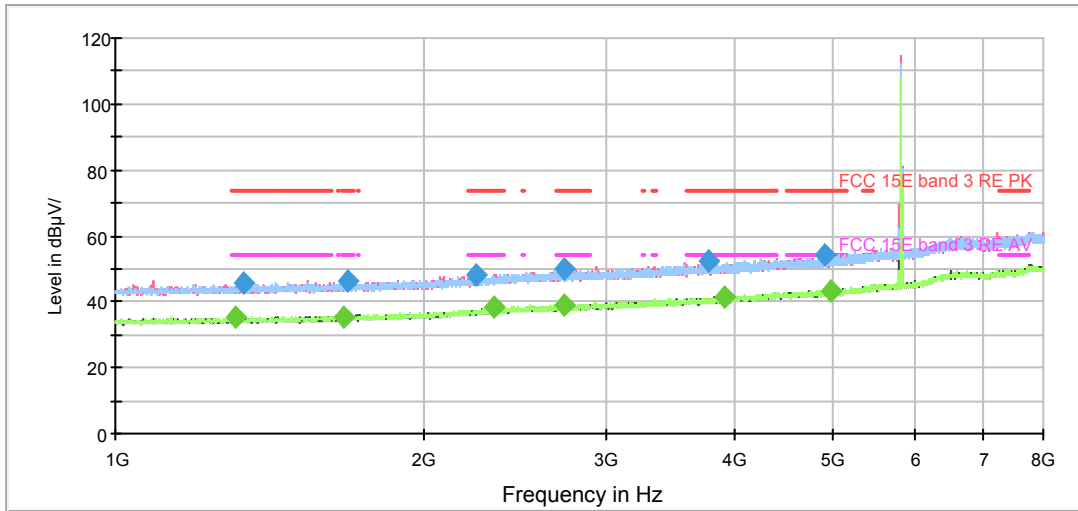

Note: The signal beyond the limit is carrier.  
Radiates Emission from 1GHz to 8GHz

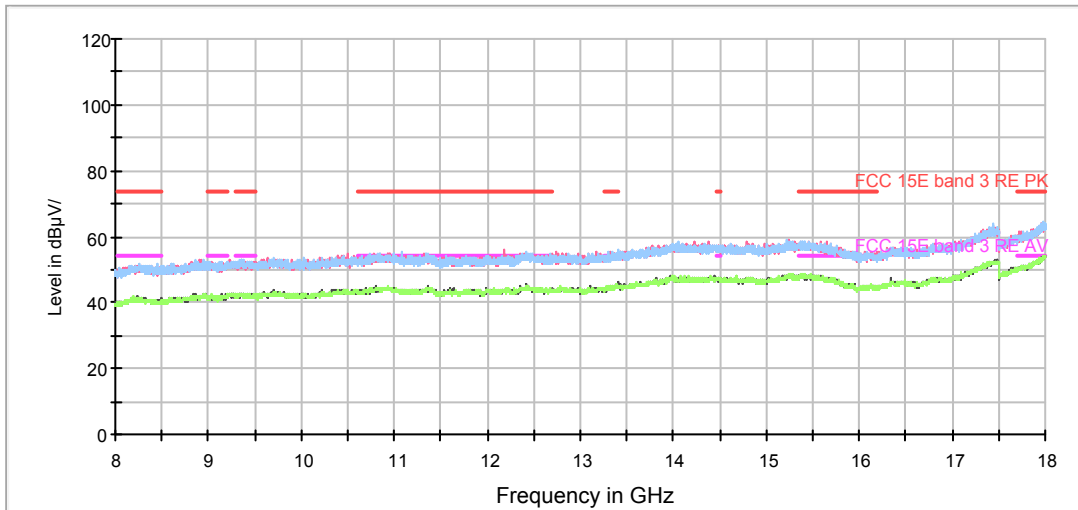

Radiates Emission from 8GHz to 18GHz



Frequency (MHz)	Peak (dBuV/m)	Height (cm)	Polarization	Azimuth (deg)	Correct Factor (dB)	Margin (dB)	Limit (dBuV/m)
1336.000000	45.4	100.0	V	0.0	-0.9	28.6	74.0
1681.625000	46.2	100.0	V	284.0	0.3	27.8	74.0
2242.500000	48.0	100.0	H	120.0	2.4	26.0	74.0
2736.000000	49.7	100.0	H	198.0	4.1	24.3	74.0
3772.000000	52.2	200.0	H	271.0	6.8	21.8	74.0
4900.750000	54.1	100.0	H	8.0	9.5	19.9	74.0

Remark: 1. Correction Factor = Antenna factor+ Insertion loss (cable loss + amplifier gain)

Frequency (MHz)	Average (dBuV/m)	Height (cm)	Polarization	Azimuth (deg)	Correct Factor (dB)	Margin (dB)	Limit (dBuV/m)
1310.625000	35.2	100.0	V	334.0	-1.0	18.8	54.0
1672.000000	35.3	100.0	V	178.0	0.3	18.7	54.0
2337.000000	38.1	100.0	V	357.0	3.0	15.9	54.0
2734.250000	39.1	200.0	V	246.0	4.1	14.9	54.0
3924.250000	41.4	200.0	V	91.0	7.1	12.6	54.0
4960.250000	43.5	200.0	V	5.0	9.5	10.5	54.0

Remark: 1. Correction Factor = Antenna factor+ Insertion loss (cable loss + amplifier gain)



## 5.6. Conducted Emission

### Ambient condition

Temperature	Relative humidity	Pressure
23°C ~25°C	45%~50%	101.5kPa

### Methods of Measurement

The EUT IS placed on a non-metallic table of 80cm height above the horizontal metal reference ground plane. During the test, the EUT was operating in its typical mode. The test method is according to ANSI C63.10-2013. Connect the AC power line of the EUT to the LISN Use EMI receiver to detect the average and Quasi-peak value. RBW is set to 9kHz, VBW is set to 30kHz The measurement result should include both L line and N line.

The test is in transmitting mode.

### Test Setup

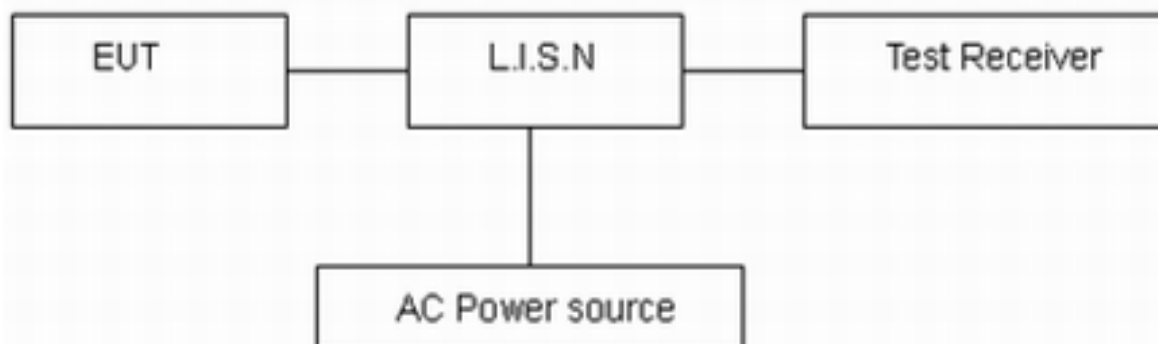

Note: AC Power source is used to change the voltage 110V/60Hz.

### Limits

Frequency (MHz)	Conducted Limits(dBμV)	
	Quasi-peak	Average
0.15 - 0.5	66 to 56 *	56 to 46*
0.5 - 5	56	46
5 - 30	60	50

\*: Decreases with the logarithm of the frequency.

### Measurement Uncertainty

The assessed measurement uncertainty to ensure 95% confidence level for the normal distribution is with the coverage factor  $k = 1.96$ ,  $U = 2.69$  dB.

**Test Results:**

Following plots, Blue trace uses the peak detection and Green trace uses the average detection. During the test, the Conducted Emission was performed in all modes with all channels, **5745M** was selected as the worst condition. The test data of the worst-case condition was recorded in this report.

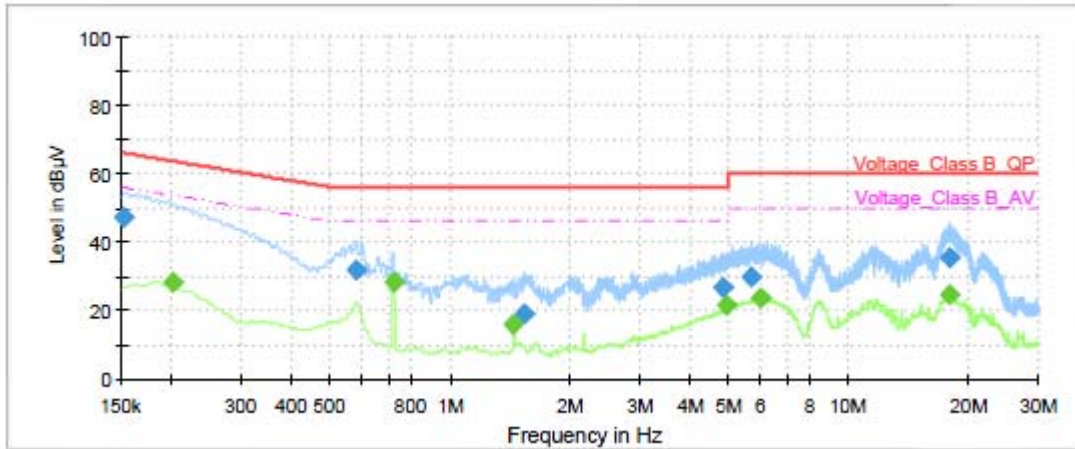

Frequency (MHz)	QuasiPeak (dBµV)	Average (dBµV)	Limit (dBµV)	Margin (dB)	Meas. Time (ms)	Bandwidth (kHz)	Line	Filter	Corr. (dB)
0.15	46.98	---	65.88	18.90	1000.0	9.000	L1	ON	19
0.20	---	28.39	53.54	25.15	1000.0	9.000	L1	ON	19
0.58	31.71	---	56.00	24.29	1000.0	9.000	L1	ON	19
0.72	---	28.45	46.00	17.55	1000.0	9.000	L1	ON	19
1.45	---	16.13	46.00	29.87	1000.0	9.000	L1	ON	19
1.53	18.88	---	56.00	37.12	1000.0	9.000	L1	ON	19
4.81	26.91	---	56.00	29.09	1000.0	9.000	L1	ON	19
4.95	---	21.29	46.00	24.71	1000.0	9.000	L1	ON	19
5.68	29.72	---	60.00	30.28	1000.0	9.000	L1	ON	19
6.01	---	23.61	50.00	26.39	1000.0	9.000	L1	ON	19
17.96	---	24.84	50.00	25.16	1000.0	9.000	L1	ON	20
18.01	35.51	---	60.00	24.49	1000.0	9.000	L1	ON	20

**Remark: Correct factor=cable loss + LISN factor**

L line Conducted Emission from 150 KHz to 30 MHz

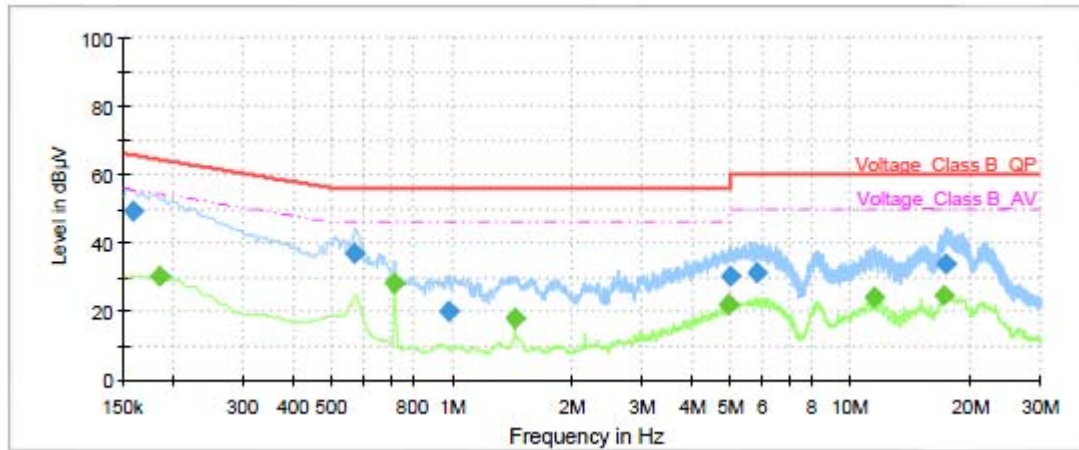

Frequency (MHz)	QuasiPeak (dBµV)	Average (dBµV)	Limit (dBµV)	Margin (dB)	Meas. Time (ms)	Bandwidth (kHz)	Line	Filter	Corr. (dB)
0.16	49.17	---	65.52	16.35	1000.0	9.000	N	ON	19
0.18	---	30.45	54.31	23.86	1000.0	9.000	N	ON	19
0.57	36.71	---	56.00	19.29	1000.0	9.000	N	ON	19
0.72	---	28.31	46.00	17.69	1000.0	9.000	N	ON	19
0.98	19.88	---	56.00	36.12	1000.0	9.000	N	ON	19
1.44	---	18.05	46.00	27.95	1000.0	9.000	N	ON	19
4.93	---	22.28	46.00	23.72	1000.0	9.000	N	ON	19
4.98	30.18	---	56.00	25.82	1000.0	9.000	N	ON	19
5.85	31.08	---	60.00	28.92	1000.0	9.000	N	ON	19
11.52	---	23.95	50.00	26.05	1000.0	9.000	N	ON	19
17.28	---	24.80	50.00	25.20	1000.0	9.000	N	ON	20
17.33	34.07	---	60.00	25.93	1000.0	9.000	N	ON	20

**Remark: Correct factor=cable loss + LISN factor**

N line Conducted Emission from 150 KHz to 30 MHz



## 6. Main Test Instruments

Name	Manufacturer	Type	Serial Number	Calibration Date	Expiration Time
Spectrum Analyzer	R&S	FSV40	15195-01-00	2019-05-19	2020-05-18
Spectrum Analyzer	Key sight	N9010A	MY50210259	2019-12-15	2020-12-14
Trilog Antenna	Schwarzbeck	VULB 9163	9163-201	2017-11-18	2020-11-17
Horn Antenna	R&S	HF907	100126	2018-07-07	2020-07-06
Wideband radio communication tester	R&S	CMW500	150415	2019-05-19	2020-05-18
Signal analyzer	R&S	FSQ 26	101132	2019-05-19	2020-05-18
Baseband signal generator and fading simulator	R&S	AMU 200A	100577	2019-05-19	2020-05-18
Vector signal generator	R&S	SMU 200A	104652	2019-05-19	2020-05-18
Signal generator	R&S	SMF 100A	102235	2019-05-19	2020-05-18
MOB COMMS DC SUPPLY	Keysight	66319D	MY43004105	2019-05-19	2020-05-18
Climate Chamber	ESPEC	SU-242	93000506	2017-12-17	2020-12-16
Software	R&S	EMC32	9.26.0	/	/

\*\*\*\*\*END OF REPORT \*\*\*\*\*