



RF TEST REPORT

Applicant Shanghai Smawave Technology Co. ,Ltd
FCC ID 2AU8HSRG411-B
Product LTE CPE
Brand Smawave
Model SRG411-b
Report No. R2001A0012-R2V1
Issue Date May 7, 2020

TA Technology (Shanghai) Co., Ltd. tested the above equipment in accordance with the requirements in **FCC CFR47 Part 15E (2019)**. The test results show that the equipment tested is capable of demonstrating compliance with the requirements as documented in this report.

Performed by: Peng Tao

Approved by: Kai Xu

TA Technology (Shanghai) Co., Ltd.

No.145, Jintang Rd, Tangzhen Industry Park, Pudong Shanghai, China

TEL: +86-021-50791141/2/3

FAX: +86-021-50791141/2/3-8000



TABLE OF CONTENT

1. Test Laboratory.....	4
1.1. Notes of the test report.....	4
1.2. Testing Location.....	4
2. General Description of Equipment under Test.....	5
2.1. Applicant and Manufacturer Information.....	5
2.2. General information.....	5
3. Applied Standards.....	6
4. Test Configuration.....	7
5. Test Case Results.....	9
5.1. Occupied Bandwidth.....	9
5.2. Average Power Output –Conducted.....	20
5.3. Frequency Stability.....	28
5.4. Power Spectral Density.....	31
5.5. Unwanted Emission.....	63
5.6. Conducted Emission.....	108
6. Main Test Instruments.....	111



Summary of measurement results

Number	Test Case	Clause in FCC rules	Verdict
1	Average conducted output power	15.407(a)	PASS
2	Occupied bandwidth	15.407(e)	PASS
3	Frequency stability	15.407(g)	PASS
4	Power spectral density	15.407(a)	PASS
5	Unwanted Emissions	15.407(b)	PASS
6	Conducted Emissions	15.207	PASS
Date of Testing: January 9, 2020~ March 31, 2020			
Note: All indications of Pass/Fail in this report are opinions expressed by TA Technology (Shanghai) Co., Ltd. based on interpretations and/or observations of test results. Measurement Uncertainties were not taken into account and are published for informational purposes only.			

Note: This revised report (Report No.: R2001A0012-R2V1) supersedes and replaces the previously issued report (Report No.: R2001A0012-R2). Please discard or destroy the previously issued report and dispose of it accordingly.



1. Test Laboratory

1.1. Notes of the test report

This report shall not be reproduced in full or partial, without the written approval of **TA technology (shanghai) co., Ltd.** The results documented in this report apply only to the tested sample, under the conditions and modes of operation as described herein. Measurement Uncertainties were not taken into account and are published for informational purposes only. This report is written to support regulatory compliance of the applicable standards stated above.

1.2. Test facility

FCC (Designation number: CN1179, Test Firm Registration Number: 446626)

TA Technology (Shanghai) Co., Ltd. has been listed on the US Federal Communications Commission list of test facilities recognized to perform electromagnetic emissions measurements.

A2LA (Certificate Number: 3857.01)

TA Technology (Shanghai) Co., Ltd. has been listed by American Association for Laboratory Accreditation to perform electromagnetic emission measurement.

1.3. Testing Location

Company: TA Technology (Shanghai) Co., Ltd.
Address: No.145, Jintang Rd, Tangzhen Industry Park, Pudong
City: Shanghai
Post code: 201201
Country: P. R. China
Contact: Xu Kai
Telephone: +86-021-50791141/2/3
Fax: +86-021-50791141/2/3-8000
Website: <http://www.ta-shanghai.com>
E-mail: xukai@ta-shanghai.com

2. General Description of Equipment under Test

2.1. Applicant and Manufacturer Information

Applicant	Shanghai Smawave Technology Co. ,Ltd
Applicant address	3/F, Building 8, 1001 North Qinzhou Road , Xuhui District, Shanghai, China
Manufacturer	Shanghai Smawave Technology Co. ,Ltd
Manufacturer address	3/F, Building 8, 1001 North Qinzhou Road , Xuhui District, Shanghai, China

2.2. General information

EUT Description	
Model	SRG411-b
SN	1#
Hardware Version	V1.0
Software Version	SG625U
Power Supply	DC adapter
Antenna Type	External Antenna
Antenna Gain	5dBi
Directional Gain	NA
Test Mode(s)	U-NII-1(5150MHz-5250MHz) U-NII-3(5725MHz-5850MHz)
Modulation Type	802.11a/n (HT20/HT40) : OFDM 802.11ac (VHT20/VHT40/VHT80): OFDM
Max. Conducted Power	20.08 dBm
Operating Frequency Range(s)	U-NII-1: 5150-5250MHz U-NII-3: 5725-5850MHz
Operating temperature range:	-40° C to 70° C
Operating voltage range:	9 V to 14 V
State DC voltage:	12V
Note:1. The EUT is sent from the applicant to TA and the information of the EUT is declared by the applicant	



3. Applied Standards

According to the specifications of the manufacturer, it must comply with the requirements of the following standards:

Test standards:

FCC CFR47 Part 15E (2019) Unlicensed National Information Infrastructure Devices

ANSI C63.10 (2013)

Reference standard:

KDB 789033 D02 General UNII Test Procedures New Rules v02r01

KDB 662911 D01 Multiple Transmitter Output v02r01

4. Test Configuration

Test Mode

The EUT has been associated with peripherals and configuration operated in a manner tended to maximize its emission characteristics in a typical application.

The radiated emission was measured in the following position: EUT stand-up position (Z axis), lie-down position (X, Y axis). The worst emission was found in lie-down position (X axis) and the worst case was recorded.

In order to find the worst case condition, Pre-tests are needed at the presence of different data rate. Preliminary tests have been done on all the configuration for confirming worst case. Data rate below means worst-case rate of each test item.

Worst-case data rates are shown as following table.

Band	Data Rate		
	Antenna 1	Antenna 2	MIMO
802.11a	6 Mbps	6 Mbps	MCS8
802.11n HT20	MCS0	MCS0	MCS8
802.11n HT40	MCS0	MCS0	MCS8
802.11ac VHT20	MCS0	MCS0	MCS8
802.11ac VHT40	MCS0	MCS0	MCS8
802.11ac VHT80	MCS0	MCS0	MCS8

The worst case Antenna mode for each of the following tests for Wi-Fi:

Test Cases	Antenna 1	Antenna 2	MIMO
Average conducted output power	O	O	O
Occupied bandwidth	--	--	O
Frequency stability	--	--	802.11a
Power Spectral Density	O	O	O
Unwanted Emissions	--	--	802.11a 802.11n HT20/40 802.11ac 80
Conducted Emissions	--	--	802.11a
Note: "O": test all bands			

According to RF Output power results in chapter 5.2, MIMO was selected as the worst antenna.

**Wireless Technology and Frequency Range**

Wireless Technology		Bandwidth	Channel	Frequency	
Wi-Fi	U-NII-1	20 MHz	36	5180MHz	
			40	5200MHz	
			44	5220MHz	
			48	5240MHz	
		40 MHz	38	5190MHz	
			46	5230MHz	
	U-NII-3	80 MHz	42	5210MHz	
			20 MHz	149	5745MHz
				153	5765MHz
		157		5785MHz	
		161		5805MHz	
		165		5825MHz	
		40 MHz	151	5755MHz	
			159	5795MHz	
80 MHz	155	5775MHz			

5. Test Case Results

5.1. Occupied Bandwidth

Ambient condition

Temperature	Relative humidity	Pressure
23°C ~25°C	45%~50%	101.5kPa

Method of Measurement

The EUT was connected to the spectrum analyzer through an external attenuator (20dB) and a known loss cable.

For U-NII-1, set RBW $\approx 1\%$ OCB kHz, VBW $\geq 3 \times$ RBW, measure the maximum width of the emission that is constrained by the frequencies associated with the two outermost amplitude points (upper and lower frequencies) that are attenuated by 26 dB relative to the maximum level measured in the fundamental emission.

For U-NII-3, Set RBW = 100 kHz, VBW $\geq 3 \times$ RBW, measure the maximum width of the emission that is constrained by the frequencies associated with the two outermost amplitude points (upper and lower frequencies) that are attenuated by 6 dB relative to the maximum level measured in the fundamental emission.

Note: The automatic bandwidth measurement capability of a spectrum analyzer or EMI receiver may be employed if it implements the functionality described above.

Use the 99 % power bandwidth function of the instrument

Test Setup

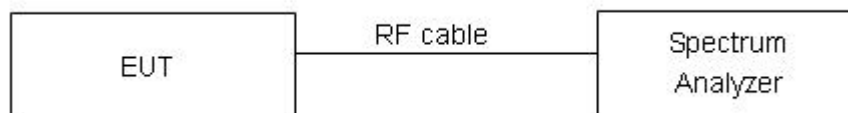

Limits

Rule FCC Part §15.407(e)

Within the 5.725-5.85 GHz band, the minimum 6 dB bandwidth of U-NII devices shall be at least 500 kHz.

Measurement Uncertainty

The assessed measurement uncertainty to ensure 95% confidence level for the normal distribution is with the coverage factor $k = 2$, $U = 936$ Hz.

**Test Results:****MIMO:****U-NII-1**

Network Standards	Carrier frequency (MHz)	99% bandwidth (MHz)	Minimum 26 dB bandwidth (MHz)	Conclusion
802.11a	5180	16.469	19.54	PASS
	5200	16.470	19.48	PASS
	5240	16.482	19.28	PASS
802.11n HT20	5180	17.612	20.41	PASS
	5200	17.587	20.24	PASS
	5240	17.611	20.28	PASS
802.11n HT40	5190	36.350	41.61	PASS
	5230	36.394	41.53	PASS
802.11ac VHT20	5180	17.596	20.49	PASS
	5200	17.635	20.44	PASS
	5240	17.619	20.13	PASS
802.11ac VHT40	5190	36.332	41.55	PASS
	5230	36.388	41.35	PASS
802.11ac VHT80	5210	75.915	102.70	PASS

U-NII-3

Network Standards	Carrier frequency (MHz)	99% bandwidth (MHz)	Minimum 6 dB bandwidth (MHz)	Limit (kHz)	Conclusion
802.11a	5745	16.451	16.40	500	PASS
	5785	16.461	16.45	500	PASS
	5825	16.431	16.42	500	PASS
802.11n HT20	5745	17.596	16.87	500	PASS
	5785	17.629	16.82	500	PASS
	5825	17.604	17.34	500	PASS
802.11n HT40	5755	36.422	36.10	500	PASS
	5795	36.339	36.08	500	PASS
802.11ac VHT20	5745	17.580	17.19	500	PASS
	5785	17.601	17.07	500	PASS
	5825	17.610	17.04	500	PASS
802.11ac VHT40	5755	36.387	36.15	500	PASS
	5795	36.366	36.10	500	PASS
802.11ac VHT80	5775	75.800	75.30	500	PASS



U-NII-1, 802.11a
Carrier frequency (MHz): 5180

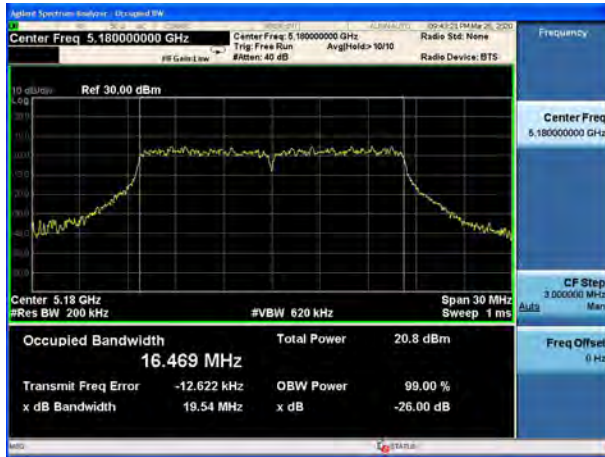

U-NII-1, 802.11n HT20
Carrier frequency (MHz): 5180



U-NII-1, 802.11a
Carrier frequency (MHz): 5200



U-NII-1, 802.11n HT20
Carrier frequency (MHz): 5200



U-NII-1, 802.11a
Carrier frequency (MHz): 5240



U-NII-1, 802.11n HT20
Carrier frequency (MHz): 5240



U-NII-1, 802.11n HT40
Carrier frequency (MHz): 5190



U-NII-1, 802.11ac VHT20
Carrier frequency (MHz): 5180



U-NII-1, 802.11n HT40
Carrier frequency (MHz): 5230



U-NII-1, 802.11ac VHT20
Carrier frequency (MHz): 5200



U-NII-1, 802.11ac VHT40
Carrier frequency (MHz): 5190



U-NII-1, 802.11ac VHT20
Carrier frequency (MHz): 5240

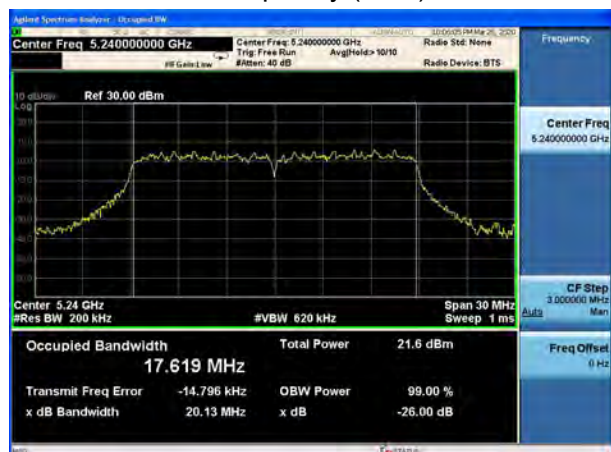



U-NII-1, 802.11ac VHT40
Carrier frequency (MHz): 5230

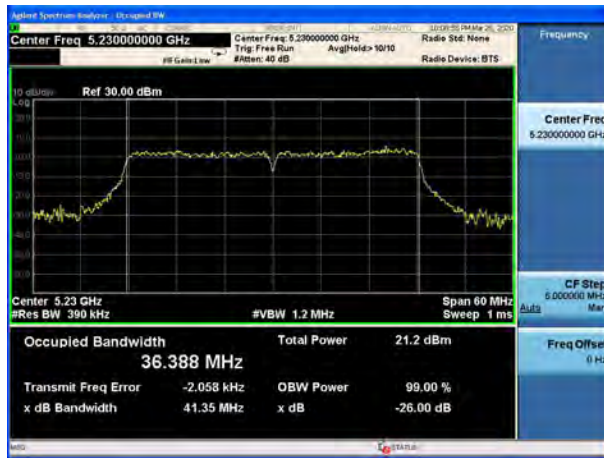

U-NII-1, 802.11ac VHT80
Carrier frequency (MHz): 5210





99% bandwidth

U-NII-3, 802.11a
Carrier frequency (MHz): 5745



U-NII-3, 802.11n HT20
Carrier frequency (MHz): 5745



U-NII-3, 802.11a
Carrier frequency (MHz): 5785



U-NII-3, 802.11n HT20
Carrier frequency (MHz): 5785

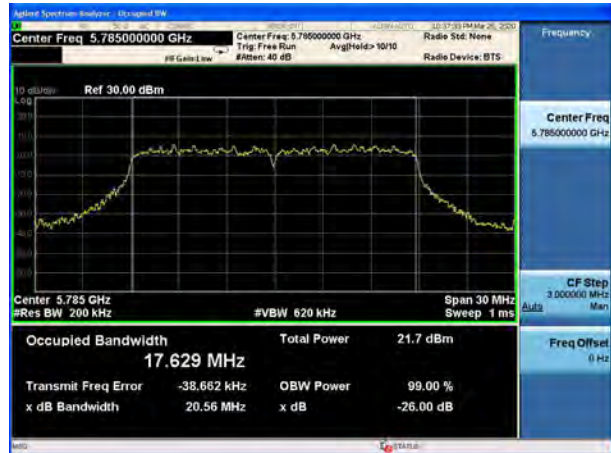

U-NII-3, 802.11a
Carrier frequency (MHz): 5825



U-NII-3, 802.11n HT20
Carrier frequency (MHz): 5825



U-NII-3, 802.11n HT40
Carrier frequency (MHz): 5755



U-NII-3, 802.11ac VHT20
Carrier frequency (MHz): 5745

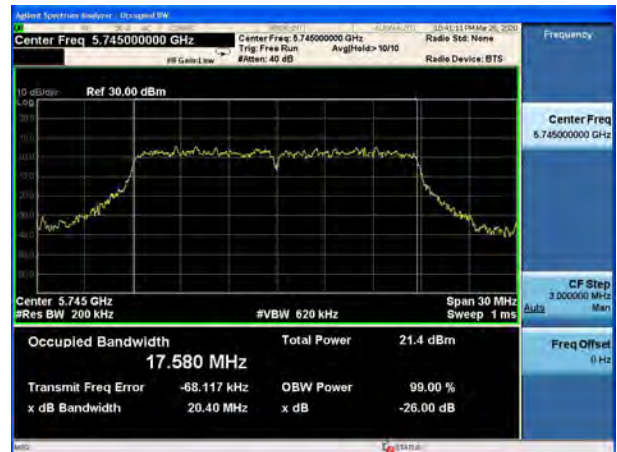

U-NII-3, 802.11n HT40
Carrier frequency (MHz): 5795

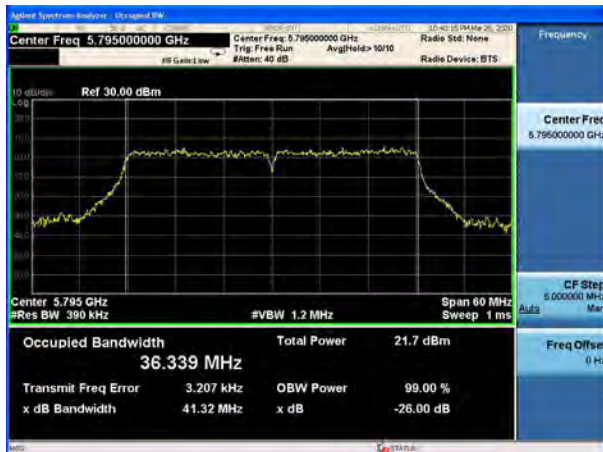

U-NII-3, 802.11ac VHT20
Carrier frequency (MHz): 5785



U-NII-3, 802.11ac VHT40
Carrier frequency (MHz): 5755



U-NII-3, 802.11ac VHT20
Carrier frequency (MHz): 5825





U-NII-3, 802.11ac VHT40
Carrier frequency (MHz): 5795



U-NII-3, 802.11ac VHT80
Carrier frequency (MHz): 5775





Minimum 6 dB bandwidth

U-NII-3, 802.11a
Carrier frequency (MHz): 5745

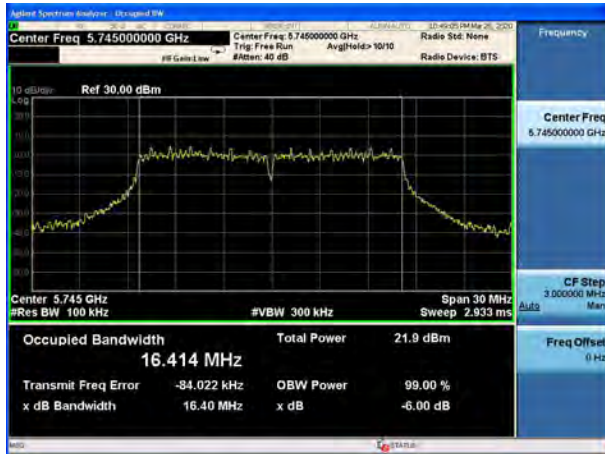

U-NII-3, 802.11n HT20
Carrier frequency (MHz): 5745

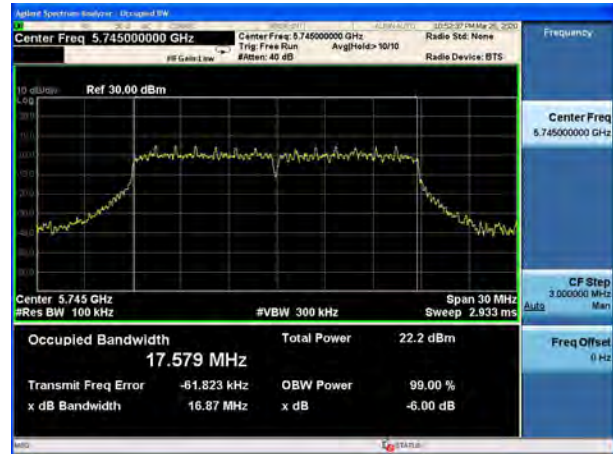

U-NII-3, 802.11a
Carrier frequency (MHz): 5785

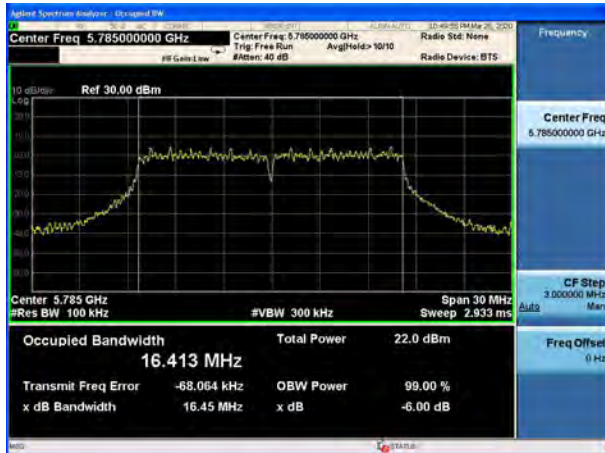

U-NII-3, 802.11n HT20
Carrier frequency (MHz): 5785

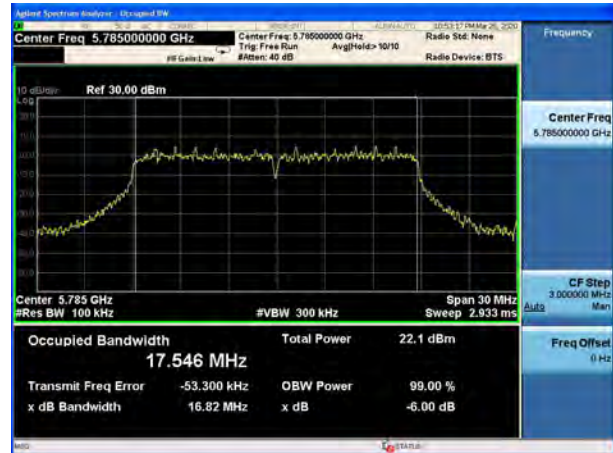

U-NII-3, 802.11a
Carrier frequency (MHz): 5825

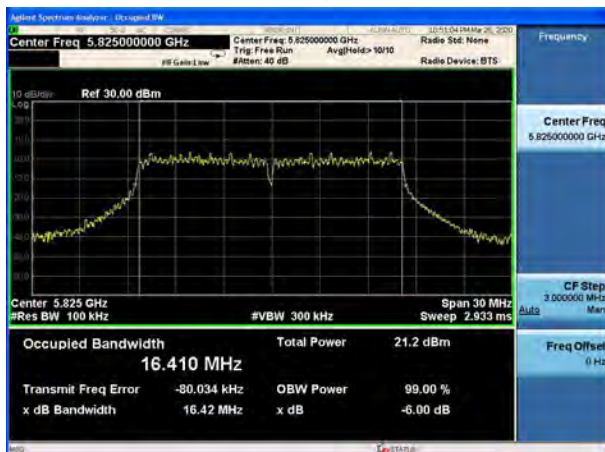

U-NII-3, 802.11n HT20
Carrier frequency (MHz): 5825

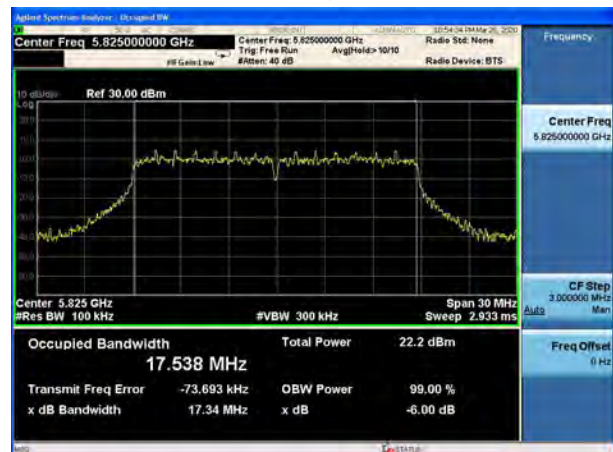

U-NII-3, 802.11n HT40
Carrier frequency (MHz): 5755

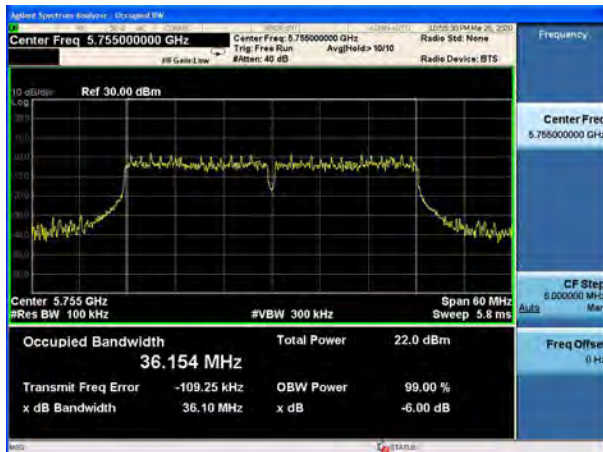

U-NII-3, 802.11ac VHT20
Carrier frequency (MHz): 5745

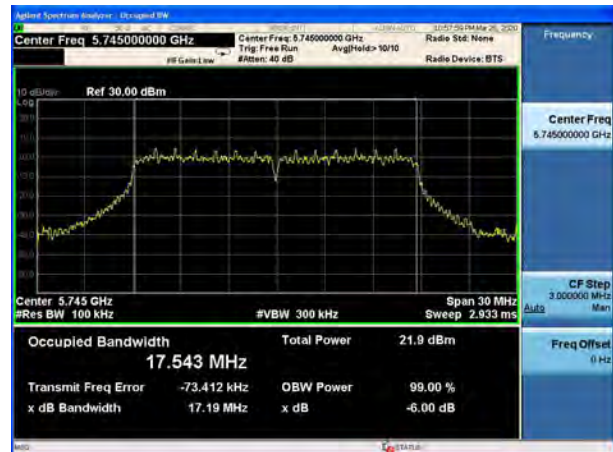

U-NII-3, 802.11n HT40
Carrier frequency (MHz): 5795

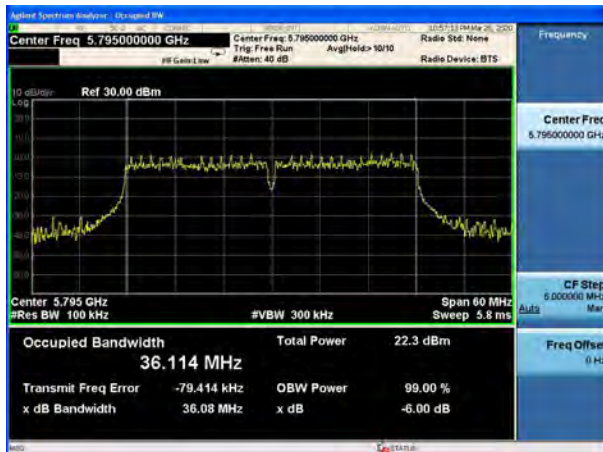

U-NII-3, 802.11ac VHT20
Carrier frequency (MHz): 5785

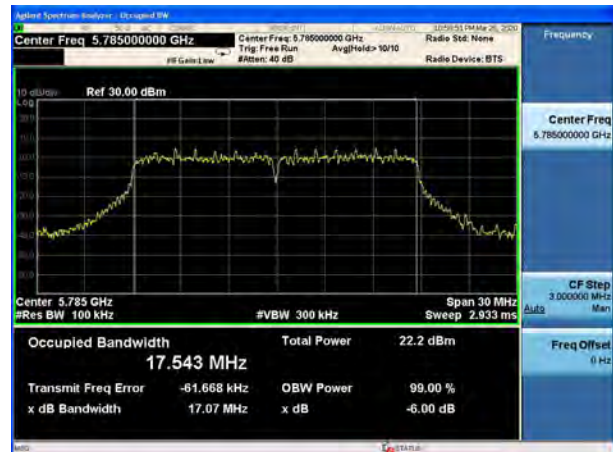

U-NII-3, 802.11ac VHT40
Carrier frequency (MHz): 5755

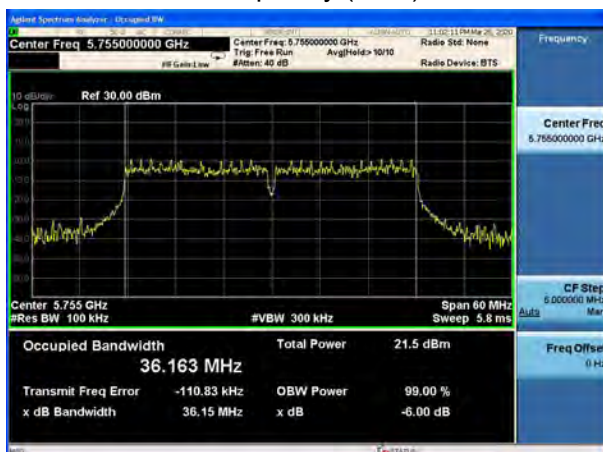

U-NII-3, 802.11ac VHT20
Carrier frequency (MHz): 5825

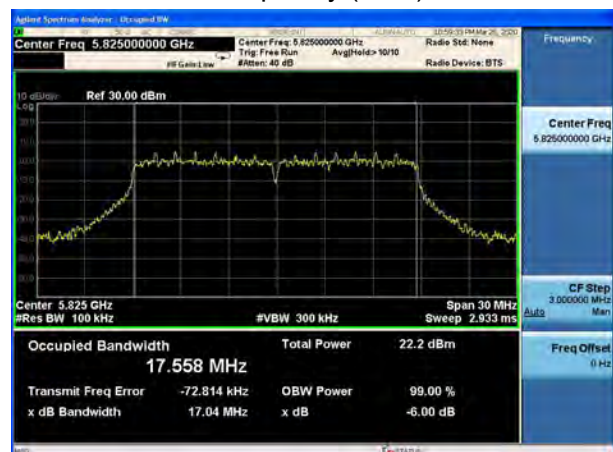



U-NII-3, 802.11ac VHT40
Carrier frequency (MHz): 5795

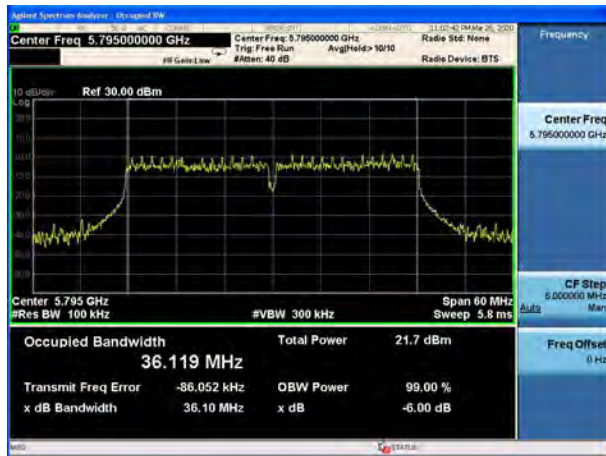

U-NII-3, 802.11ac VHT80
Carrier frequency (MHz): 5775

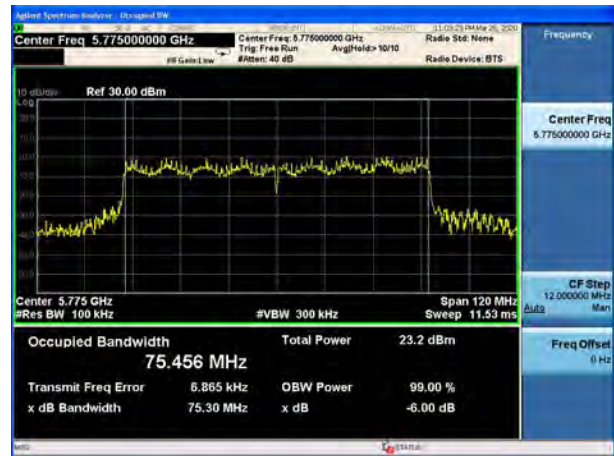

5.2. Average Power Output –Conducted

Ambient condition

Temperature	Relative humidity	Pressure
23°C ~25°C	45%~50%	101.5kPa

Methods of Measurement

During the process of the testing, The EUT was connected to the average power meter through an external attenuator and a known loss cable. The EUT is max power transmission with proper modulation. We use Maximum average Conducted Output Power Level Method in KDB789033 for this test

The conducted Power is measured at each antenna port. The measured results at the various antenna ports are then summed mathematically.

Test Setup

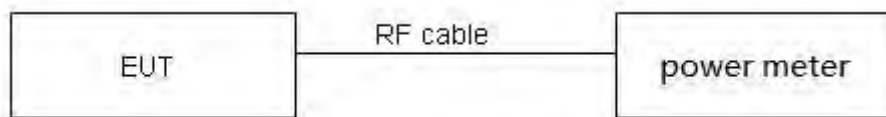

Limits

Rule FCC Part 15.407(a)(1)(2)(3)

(1) For the band 5.15-5.25 GHz.

(i) For an outdoor access point operating in the band 5.15-5.25 GHz, the maximum conducted output power over the frequency band of operation shall not exceed 1 W provided the maximum antenna gain does not exceed 6 dBi. In addition, the maximum power spectral density shall not exceed 17 dBm in any 1 megahertz band. If transmitting antennas of directional gain greater than 6 dBi are used, both the maximum conducted output power and the maximum power spectral density shall be reduced by the amount in dB that the directional gain of the antenna exceeds 6 dBi. The maximum e.i.r.p. at any elevation angle above 30 degrees as measured from the horizon must not exceed 125 mW (21 dBm).

(ii) For an indoor access point operating in the band 5.15-5.25 GHz, the maximum conducted output power over the frequency band of operation shall not exceed 1 W provided the maximum antenna gain does not exceed 6 dBi. In addition, the maximum power spectral density shall not exceed 17 dBm in any 1 megahertz band. If transmitting antennas of directional gain greater than 6 dBi are used, both the maximum conducted output power and the maximum power spectral density shall be reduced by the amount in dB that the directional gain of the antenna exceeds 6 dBi.

(iii) For fixed point-to-point access points operating in the band 5.15-5.25 GHz, the maximum conducted output power over the frequency band of operation shall not exceed 1 W. In addition, the maximum power spectral density shall not exceed 17 dBm in any 1 megahertz band. Fixed point-to-point U-NII devices may employ antennas with directional gain up to 23 dBi without any corresponding reduction in the maximum conducted output power or maximum power spectral density. For fixed point-to-point transmitters that employ a directional antenna gain greater than 23



dBi, a 1 dB reduction in maximum conducted output power and maximum power spectral density is required for each 1 dB of antenna gain in excess of 23 dBi. Fixed, point-to-point operations exclude the use of point-to-multipoint systems, omnidirectional applications, and multiple collocated transmitters transmitting the same information. The operator of the U-NII device, or if the equipment is professionally installed, the installer, is responsible for ensuring that systems employing high gain directional antennas are used exclusively for fixed, point-to-point operations.

(iv) For client devices in the 5.15-5.25 GHz band, the maximum conducted output power over the frequency band of operation shall not exceed 250 mW provided the maximum antenna gain does not exceed 6 dBi. In addition, the maximum power spectral density shall not exceed 11 dBm in any 1 megahertz band. If transmitting antennas of directional gain greater than 6 dBi are used, both the maximum conducted output power and the maximum power spectral density shall be reduced by the amount in dB that the directional gain of the antenna exceeds 6 dBi.

(2) For the band 5.725-5.85 GHz, the maximum conducted output power over the frequency band of operation shall not exceed 1 W. In addition, the maximum power spectral density shall not exceed 30 dBm in any 500-kHz band. If transmitting antennas of directional gain greater than 6 dBi are used, both the maximum conducted output power and the maximum power spectral density shall be reduced by the amount in dB that the directional gain of the antenna exceeds 6 dBi.

Measurement Uncertainty

The assessed measurement uncertainty to ensure 95% confidence level for the normal distribution is with the coverage factor $k = 2$, $U = 0.44$ dB.



Test Results

Band	T _{on} (ms)	T _(on+off) (ms)	Duty cycle	Duty cycle correction Factor(dB)
802.11a	0.25	0.35	0.71	1.50
802.11n HT20	0.23	0.32	0.72	1.42
802.11n HT40	0.13	0.22	0.59	2.27
802.11ac VHT20	0.23	0.30	0.75	1.25
802.11ac VHT40	0.13	0.24	0.53	2.77
802.11ac VHT80	0.23	0.29	0.78	1.08

Note: when Duty cycle>0.98, Duty cycle correction Factor not required.

Single Antenna 1 Power Index						
Packet Type	CH36	CH40	CH48	CH149	CH157	CH165
802.11a	56	57	56	55	55	53
802.11n HT20	56	57	56	55	55	53
802.11ac VHT20	57	58	57	55	55	53
Packet Type	CH38	CH46	CH151	CH159	/	/
802.11n HT40	56	56	54	54	/	/
802.11ac VHT40	55	55	53	53	/	/
Packet Type	CH42	CH155	/	/	/	/
802.11ac VHT80	56	55	/	/	/	/

Single Antenna 2 Power Index						
Packet Type	CH36	CH40	CH48	CH149	CH157	CH165
802.11a	56	57	55	52	52	50
802.11n HT20	56	59	55	52	51	49
802.11ac VHT20	57	59	56	52	51	49
Packet Type	CH38	CH46	CH151	CH159	/	/
802.11n HT40	55	55	50	48	/	/
802.11ac VHT40	55	55	49	47	/	/
Packet Type	CH42	CH155	/	/	/	/
802.11ac VHT80	56	50	/	/	/	/



MIMO Antenna 1/2 Power Index						
Packet Type	CH36	CH40	CH48	CH149	CH157	CH165
802.11a	50	51	51	48	47	44
802.11n HT20	51	52	51	48	47	45
802.11ac VHT20	51	51	51	47	47	45
Packet Type	CH38	CH46	CH151	CH159	/	/
802.11n HT40	50	50	46	44	/	/
802.11ac VHT40	50	49	45	43	/	/
Packet Type	CH42	CH155	/	/	/	/
802.11ac VHT80	51	47	/	/	/	/

SISO Antenna 1:**U-NII-1**

Network Standards	Channel/ Frequency (MHz)	Average Power Measured (dBm)	Average Power with duty factor (dBm)	Limit (dBm)	Conclusion
802.11a	36/5180	17.79	19.29	24	PASS
	40/5200	18.03	19.53	24	PASS
	48/5240	18.39	19.89	24	PASS
802.11n HT20	36/5180	17.83	19.25	24	PASS
	40/5200	17.92	19.34	24	PASS
	48/5240	18.26	19.68	24	PASS
802.11n HT40	38/5190	17.43	19.70	24	PASS
	46/5230	17.55	19.82	24	PASS
802.11ac VHT20	36/5180	18.09	19.34	24	PASS
	40/5200	18.32	19.57	24	PASS
	48/5240	18.58	19.83	24	PASS
802.11ac VHT40	38/5190	17.06	19.83	24	PASS
	46/5230	17.17	19.94	24	PASS
802.11ac VHT80	42/5210	18.23	19.31	24	PASS

Note: Average Power with duty factor = Average Power Measured +Duty cycle correction factor



U-NII-3

Network Standards	Channel/ Frequency (MHz)	Average Power Measured (dBm)	Average Power with duty factor (dBm)	Limit (dBm)	Conclusion
802.11a	149/5745	18.23	19.73	30	PASS
	157/5785	18.16	19.66	30	PASS
	165/5825	18.42	19.92	30	PASS
802.11n HT20	149/5745	18.17	19.59	30	PASS
	157/5785	18.15	19.57	30	PASS
	165/5825	18.27	19.69	30	PASS
802.11n HT40	151/5755	17.11	19.38	30	PASS
	159/5795	17.69	19.96	30	PASS
802.11ac VHT20	149/5745	18.35	19.60	30	PASS
	157/5785	18.12	19.37	30	PASS
	165/5825	18.62	19.87	30	PASS
802.11ac VHT40	151/5755	17.17	19.94	30	PASS
	159/5795	17.23	20.00	30	PASS
802.11ac VHT80	155/5775	18.38	19.46	30	PASS

Note: Average Power with duty factor = Average Power Measured +Duty cycle correction factor

**SISO Antenna 2:****U-NII-1**

Network Standards	Channel/ Frequency (MHz)	Average Power Measured (dBm)	Average Power with duty factor (dBm)	Limit (dBm)	Conclusion
802.11a	36/5180	18.20	19.70	24	PASS
	40/5200	18.07	19.57	24	PASS
	48/5240	18.15	19.65	24	PASS
802.11n HT20	36/5180	18.19	19.61	24	PASS
	40/5200	17.98	19.40	24	PASS
	48/5240	18.13	19.55	24	PASS
802.11n HT40	38/5190	17.14	19.41	24	PASS
	46/5230	17.16	19.43	24	PASS
802.11ac VHT20	36/5180	18.21	19.46	24	PASS
	40/5200	18.43	19.68	24	PASS
	48/5240	18.26	19.51	24	PASS
802.11ac VHT40	38/5190	17.27	20.04	24	PASS
	46/5230	17.21	19.98	24	PASS
802.11ac VHT80	42/5210	18.19	19.27	24	PASS

Note: Average Power with duty factor = Average Power Measured +Duty cycle correction factor

U-NII-3

Network Standards	Channel/ Frequency (MHz)	Average Power Measured (dBm)	Average Power with duty factor (dBm)	Limit (dBm)	Conclusion
802.11a	149/5745	18.32	19.82	30	PASS
	157/5785	18.06	19.56	30	PASS
	165/5825	18.29	19.79	30	PASS
802.11n HT20	149/5745	18.27	19.69	30	PASS
	157/5785	18.32	19.74	30	PASS
	165/5825	18.48	19.90	30	PASS
802.11n HT40	151/5755	17.32	19.59	30	PASS
	159/5795	17.43	19.70	30	PASS
802.11ac VHT20	149/5745	18.33	19.58	30	PASS
	157/5785	18.46	19.71	30	PASS
	165/5825	18.54	19.79	30	PASS
802.11ac VHT40	151/5755	16.72	19.49	30	PASS
	159/5795	17.06	19.83	30	PASS
802.11ac VHT80	155/5775	18.11	19.19	30	PASS

Note: Average Power with duty factor = Average Power Measured +Duty cycle correction factor

**MIMO:****U-NII-1**

Network Standards	Channel/ Frequency (MHz)	MIMO Antenna 1		MIMO Antenna 2		Total Power (dBm)	Limit (dBm)	Conclusion
		Average Power Measured (dBm)	Average Power with duty factor (dBm)	Average Power Measured (dBm)	Average Power with duty factor (dBm)			
U-NII-1 802.11a	36/5180	14.28	15.78	15.13	16.63	19.23	24.00	PASS
	40/5200	14.43	15.93	14.68	16.18	19.06	24.00	PASS
	48/5240	15.24	16.74	15.29	16.79	19.77	24.00	PASS
802.11n HT20	36/5180	14.62	16.04	14.92	16.34	19.20	24.00	PASS
	40/5200	14.96	16.38	15.33	16.75	19.58	24.00	PASS
	48/5240	15.19	16.61	15.32	16.74	19.68	24.00	PASS
802.11n HT40	38/5190	14.16	16.43	14.37	16.64	19.55	24.00	PASS
	46/5230	14.47	16.74	14.75	17.02	19.89	24.00	PASS
802.11ac VHT20	36/5180	14.91	16.16	15.33	16.58	19.38	24.00	PASS
	40/5200	15.16	16.41	14.98	16.23	19.33	24.00	PASS
	48/5240	15.23	16.48	15.36	16.61	19.56	24.00	PASS
802.11ac VHT40	38/5190	14.06	16.83	14.54	17.31	20.08	24.00	PASS
	46/5230	13.96	16.73	14.53	17.30	20.03	24.00	PASS
802.11ac VHT80	42/5210	15.19	16.27	15.43	16.51	19.40	24.00	PASS

Note: 1. For Total Power, according to KDB 662911 D01 Multiple Transmitter Output v02r01 1),

The Total Power = $10\log(10^{(\text{Power antenna1 in dBm}/10)} + 10^{(\text{Power antenna2 in dBm}/10)})$.

2. The manufacturer declared the transmitter output signals is CDD mode And $N_{SS}=2$. According to KDB 662911 D01 Multiple Transmitter Output v02r01 2)f(i): If all antennas have the same gain, Directional gain = $G_{ANT} + \text{Array Gain}$,

For power measurements on IEEE 802.11 devices,

Array Gain = 0 dB (i.e., no array gain) for $N_{ANT} \leq 4$;

Array Gain = 0 dB (i.e., no array gain) for channel widths ≥ 40 MHz for any N_{ANT} ;

Array Gain = $5 \log(N_{ANT}/N_{SS})$ dB or 3 dB, whichever is less, for 20-MHz channel widths with $N_{ANT} \geq 5$.

So directional gain = $G_{ANT} + \text{Array Gain} = 5 + 0 = 5$ dBi < 6dBi. So the power limit is 24dBm.



U-NII-3

Network Standards	Channel/Frequency (MHz)	MIMO Antenna 1		MIMO Antenna 2		Total Power (dBm)	Limit (dBm)	Conclusion
		Average Power Measured (dBm)	Average Power with duty factor (dBm)	Average Power Measured (dBm)	Average Power with duty factor (dBm)			
U-NII-1 802.11a	149/5745	14.86	16.36	15.81	17.31	19.87	30.00	PASS
	157/5785	14.77	16.27	16.12	17.62	20.00	30.00	PASS
	165/5825	14.34	15.84	16.15	17.65	19.85	30.00	PASS
802.11n HT20	149/5745	15.24	16.66	16.01	17.43	20.07	30.00	PASS
	157/5785	15.03	16.45	16.12	17.54	20.04	30.00	PASS
	165/5825	14.96	16.38	16.24	17.66	20.07	30.00	PASS
802.11n HT40	151/5755	13.87	16.14	14.87	17.14	19.68	30.00	PASS
	159/5795	13.93	16.20	15.01	17.28	19.79	30.00	PASS
802.11ac VHT20	149/5745	15.16	16.41	15.52	16.77	19.60	30.00	PASS
	157/5785	15.19	16.44	16.25	17.50	20.01	30.00	PASS
	165/5825	14.86	16.11	16.51	17.76	20.02	30.00	PASS
802.11ac VHT40	151/5755	13.56	16.33	14.56	17.33	19.87	30.00	PASS
	159/5795	13.49	16.26	14.82	17.59	19.98	30.00	PASS
802.11ac VHT80	155/5775	15.12	16.20	15.89	16.97	19.62	30.00	PASS

Note: 1. For Total Power, according to KDB 662911 D01 Multiple Transmitter Output v02r01 1),

The Total Power = $10\log(10^{(\text{Power antenna1 in dBm}/10)} + 10^{(\text{Power antenna2 in dBm}/10)})$.

2. The manufacturer declared the transmitter output signals is CDD mode And $N_{SS}=2$. According to KDB 662911 D01 Multiple Transmitter Output v02r01 2)f)(i): If all antennas have the same gain, Directional gain = $G_{ANT} + \text{Array Gain}$,

For power measurements on IEEE 802.11 devices,

Array Gain = 0 dB (i.e., no array gain) for $N_{ANT} \leq 4$;

Array Gain = 0 dB (i.e., no array gain) for channel widths ≥ 40 MHz for any N_{ANT} ;

Array Gain = $5 \log(N_{ANT}/N_{SS})$ dB or 3 dB, whichever is less, for 20-MHz channel widths with $N_{ANT} \geq 5$.

So directional gain = $G_{ANT} + \text{Array Gain} = 5 + 0 = 5$ dBi < 6dBi. So the power limit is 30dBm.



5.3. Frequency Stability

Ambient condition

Temperature	Relative humidity	Pressure
23°C ~25°C	45%~50%	101.5kPa

Method of Measurement

1. Frequency stability with respect to ambient temperature

- a) Supply the EUT with a nominal ac voltage or install a new or fully charged battery in the EUT. If possible, a dummy load shall be connected to the EUT because an antenna near the metallic walls of an environmental test chamber could affect the output frequency of the EUT. If the EUT is equipped with a permanently attached, adjustable-length antenna, then the EUT shall be placed in the center of the chamber with the antenna adjusted to the shortest length possible. Turn ON the EUT and tune it to one of the number of frequencies shown in 5.6.
- b) Couple the unlicensed wireless device output to the measuring instrument by connecting an antenna to the measuring instrument with a suitable length of coaxial cable and placing the measuring antenna near the EUT (e.g., 15 cm away), or by connecting a dummy load to the measuring instrument, through an attenuator if necessary.
- c) Adjust the location of the measurement antenna and the controls on the measurement instrument to obtain a suitable signal level (i.e., a level that will not overload the measurement instrument but is strong enough to allow measurement of the operating or fundamental frequency of the EUT).
- d) Turn the EUT OFF and place it inside the environmental temperature chamber. For devices that have oscillator heaters, energize only the heater circuit.
- e) Set the temperature control on the chamber to the highest specified in the regulatory requirements for the type of device and allow the oscillator heater and the chamber temperature to stabilize.
- f) While maintaining a constant temperature inside the environmental chamber, turn the EUT ON and record the operating frequency at startup, and at 2 minutes, 5 minutes, and 10 minutes after the EUT is energized. Four measurements in total are made.
- g) Measure the frequency at each of frequencies specified in 5.6.
- h) Switch OFF the EUT but do not switch OFF the oscillator heater.
- i) Lower the chamber temperature by not more than 10°C, and allow the temperature inside the chamber to stabilize.
- j) Repeat step f) through step i) down to the lowest specified temperature.

2. Frequency stability when varying supply voltage

Unless otherwise specified, these tests shall be made at ambient room temperature (+15°C to +25°C). An antenna shall be connected to the antenna output terminals of the EUT if possible. If the EUT is equipped with or uses an adjustable-length antenna, then it shall be fully extended.

- a) Supply the EUT with nominal voltage or install a new or fully charged battery in the EUT. Turn ON the EUT and couple its output to a frequency counter or other frequency-measuring instrument.



- b) Tune the EUT to one of the number of frequencies required in 5.6. Adjust the location of the measurement antenna and the controls on the measurement instrument to obtain a suitable signal level (i.e., a level that will not overload the measurement instrument but is strong enough to allow measurement of the operating or fundamental frequency of the EUT).
- c) Measure the frequency at each of the frequencies specified in 5.6.
- d) Repeat the above procedure at 85% and 115% of the nominal supply voltage.

Limit

Manufacturers of U-NII devices are responsible for ensuring frequency stability such that an emission is maintained within the band of operation under all conditions of normal operation as specified in the users manual.

Measurement Uncertainty

The assessed measurement uncertainty to ensure 95% confidence level for the normal distribution is with the coverage factor $k = 2$, $U = 936\text{Hz}$

**Test Results**

Voltage (V)	Temperature (°C)	U-NII-1 Test Results			
		5200MHz			
		1min	2min	5min	10min
12	-40	5200.006684	5200.001229	5199.993076	5199.988153
12	-20	5200.009609	5199.993819	5199.990879	5199.986638
12	0	5199.999651	5199.990064	5199.985525	5199.982324
12	10	5199.992820	5199.987846	5199.979588	5199.980775
12	20	5199.984780	5199.980941	5199.975014	5199.971051
12	30	5199.977786	5199.974430	5199.969508	5199.968941
12	60	5199.975442	5199.972129	5199.959880	5199.968255
12	70	5199.971993	5199.966528	5199.950904	5199.964032
9	25	5199.969388	5199.965963	5199.941607	5199.955929
14	25	5199.966525	5199.957975	5199.932310	5199.950034
MHz		-0.033475	-0.042025	-0.067690	-0.049966
PPM		-6.437582	-8.081688	-13.017334	-9.608905

Voltage (V)	Temperature (°C)	U-NII-3 Test Results			
		5785MHz			
		1min	2min	5min	10min
12	-40	5785.007195	5785.000153	5784.993198	5784.989238
12	-20	5785.005998	5784.993188	5784.989948	5784.983292
12	0	5784.997310	5784.989338	5784.981910	5784.977729
12	10	5784.987446	5784.980085	5784.978723	5784.976369
12	20	5784.987430	5784.973013	5784.971546	5784.970086
12	30	5784.986523	5784.972412	5784.965487	5784.964223
12	60	5784.985190	5784.968020	5784.961348	5784.961574
12	70	5784.981191	5784.966650	5784.952151	5784.958386
9	25	5784.973558	5784.962019	5784.943823	5784.953801
14	25	5784.966615	5784.952334	5784.941123	5784.947940
MHz		-0.033385	-0.047666	-0.058877	-0.052060
PPM		-5.770976	-8.239600	-10.177447	-8.999205

5.4. Power Spectral Density

Ambient condition

Temperature	Relative humidity	Pressure
23°C ~25°C	45%~50%	101.5kPa

Method of Measurement

The EUT was connected to the spectrum analyzer through an external attenuator (20dB) and a known loss cable.

Set RBW = 510 kHz, VBW =1.5MHz for the band 5.725-5.85 GHz

Set RBW = 1 MHz, VBW =3MHz for the band 5.150-5.250 GHz

The conducted PSD is measured at each antenna port. The measured results at the various antenna ports are then summed mathematically.

Test setup

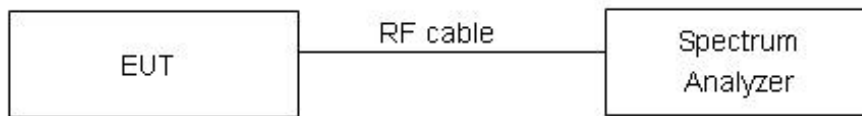

Limits

Rule FCC Part 15.407(a)(1)/ Part 15.407(a)(2) / Part 15.407(a)(3)

For an indoor access point operating in the band 5.15-5.25 GHz, the maximum power spectral density shall not exceed 17 dBm in any 1 megahertz band. If transmitting antennas of directional gain greater than 6 dBi are used, both the maximum conducted output power and the maximum power spectral density shall be reduced by the amount in dB that the directional gain of the antenna exceeds 6 dBi.

(iv) For client devices in the 5.15-5.25 GHz band, the maximum conducted output power over the frequency band of operation shall not exceed 250 mW provided the maximum antenna gain does not exceed 6 dBi. In addition, the maximum power spectral density shall not exceed 11 dBm in any 1 megahertz band. If transmitting antennas of directional gain greater than 6 dBi are used, both the maximum conducted output power and the maximum power spectral density shall be reduced by the amount in dB that the directional gain of the antenna exceeds 6 dBi.

For the band 5.725-5.85 GHz, the maximum power spectral density shall not exceed 30 dBm in any 500-kHz band. If transmitting antennas of directional gain greater than 6 dBi are used, both the maximum conducted output power and the maximum power spectral density shall be reduced by the amount in dB that the directional gain of the antenna exceeds 6 dBi.

Frequency Bands/MHz	Limits
5150-5250	17/11dBm/MHz



5725-5850

30dBm/500kHz

Measurement Uncertainty

The assessed measurement uncertainty to ensure 95% confidence level for the normal distribution is with the coverage factor $k = 2$, $U = 0.75\text{dB}$.

**Test Results:**

Note: Power Spectral Density =Read Value+Duty cycle correction factor

SISO Antenna 1:**U-NII-1**

Network Standards	Channel Number	Read Value (dBm /MHz)	Power Spectral Density (dBm /MHz)	Limit (dBm /MHz)	Conclusion
802.11a	36	6.87	8.37	11.00	PASS
	40	7.01	8.50	11.00	PASS
	48	7.66	9.15	11.00	PASS
802.11n HT20	36	6.53	7.95	11.00	PASS
	40	6.82	8.24	11.00	PASS
	48	7.41	8.83	11.00	PASS
802.11n HT40	38	3.94	6.21	11.00	PASS
	46	4.58	6.85	11.00	PASS
802.11ac VHT20	36	6.73	7.98	11.00	PASS
	40	6.57	7.82	11.00	PASS
	48	8.09	9.34	11.00	PASS
802.11ac VHT40	38	2.88	5.64	11.00	PASS
	46	3.82	6.59	11.00	PASS
802.11ac VHT80	42	2.24	3.32	11.00	PASS



U-NII-3

Network Standards	Channel Number	Read Value (dBm/500kHz)	Power Spectral Density (dBm/500kHz)	Limit (dBm/500kHz)	Conclusion
802.11a	149	4.55	6.04	30.00	PASS
	157	4.86	6.36	30.00	PASS
	165	4.87	6.37	30.00	PASS
802.11n HT20	149	4.13	5.54	30.00	PASS
	157	4.58	6.00	30.00	PASS
	165	5.26	6.67	30.00	PASS
802.11n HT40	151	1.52	3.79	30.00	PASS
	159	1.49	3.76	30.00	PASS
802.11ac VHT20	149	4.47	5.72	30.00	PASS
	157	4.62	5.87	30.00	PASS
	165	4.39	5.64	30.00	PASS
802.11ac VHT40	151	1.43	4.20	30.00	PASS
	159	0.68	3.45	30.00	PASS
802.11ac VHT80	155	-1.14	-0.05	30.00	PASS



SISO Antenna 2:

U-NII-1

Network Standards	Channel Number	Read Value (dBm /MHz)	Power Spectral Density (dBm /MHz)	Limit (dBm /MHz)	Conclusion
802.11a	36	5.72	7.22	11.00	PASS
	40	5.83	7.33	11.00	PASS
	48	5.73	7.23	11.00	PASS
802.11n HT20	36	6.05	7.46	11.00	PASS
	40	5.26	6.67	11.00	PASS
	48	5.73	7.14	11.00	PASS
802.11n HT40	38	3.28	5.55	11.00	PASS
	46	4.08	6.35	11.00	PASS
802.11ac VHT20	36	7.11	8.36	11.00	PASS
	40	7.30	8.55	11.00	PASS
	48	8.13	9.38	11.00	PASS
802.11ac VHT40	38	2.73	5.50	11.00	PASS
	46	3.26	6.03	11.00	PASS
802.11ac VHT80	42	2.95	4.03	11.00	PASS



U-NII-3

Network Standards	Channel Number	Read Value (dBm/500kHz)	Power Spectral Density (dBm/500kHz)	Limit (dBm/500kHz)	Conclusion
802.11a	149	4.23	5.73	30.00	PASS
	157	4.49	5.98	30.00	PASS
	165	4.34	5.84	30.00	PASS
802.11n HT20	149	2.44	3.85	30.00	PASS
	157	5.28	6.69	30.00	PASS
	165	4.63	6.04	30.00	PASS
802.11n HT40	151	0.15	2.42	30.00	PASS
	159	0.24	2.51	30.00	PASS
802.11ac VHT20	149	4.52	5.76	30.00	PASS
	157	5.02	6.27	30.00	PASS
	165	4.88	6.13	30.00	PASS
802.11ac VHT40	151	-0.08	2.69	30.00	PASS
	159	0.58	3.35	30.00	PASS
802.11ac VHT80	155	-0.17	0.91	30.00	PASS

**MIMO****U-NII-1**

Network Standards	Channel/ Frequency (MHz)	Power Spectral Density					Limit (dBm /MHz)	Conclusion
		Antenna 1		Antenna 2		Total Power (dBm /MHz)		
		Read Value (dBm/MHz)	PSD (dBm /MHz)	Read Value (dBm/MHz)	PSD (dBm /MHz)			
802.11a	36/5180	3.39	4.89	2.23	3.72	7.36	11.00	PASS
	40/5200	3.38	4.88	2.63	4.12	7.53	11.00	PASS
	48/5240	3.46	4.95	3.36	4.85	7.91	11.00	PASS
802.11n HT20	36/5180	3.15	4.57	2.70	4.12	7.36	11.00	PASS
	40/5200	2.89	4.31	3.15	4.57	7.45	11.00	PASS
	48/5240	3.40	4.81	2.86	4.28	7.56	11.00	PASS
802.11n HT40	38/5190	-0.48	1.80	-0.19	2.08	4.95	11.00	PASS
	46/5230	0.41	2.68	0.64	2.92	5.81	11.00	PASS
802.11ac VHT20	36/5180	2.76	4.01	3.65	4.90	7.49	11.00	PASS
	40/5200	2.62	3.87	3.08	4.33	7.11	11.00	PASS
	48/5240	3.24	4.49	3.77	5.02	7.78	11.00	PASS
802.11ac VHT40	38/5190	-1.19	1.58	0.03	2.80	5.24	11.00	PASS
	46/5230	-0.60	2.17	-0.87	1.89	5.04	11.00	PASS
802.11ac VHT80	42/5210	-1.73	-0.65	-1.13	-0.04	2.67	11.00	PASS

Note: 1. Power Spectral Density =Read Value+Duty cycle correction factor

2. For Total PSD, according to KDB 662911 D01 Multiple Transmitter Output v02r01 2)a),the power spectral density= $10\log(10^{(PSD\ antenna1\ in\ dBm/10)}+10^{(PSD\ antenna2\ in\ dBm/10)})$

3. The manufacturer declared the transmitter output signals is CDD mode And Nss=2. According to KDB 662911 D01 Multiple Transmitter Output v02r01 2)f)(i): If all antennas have the same gain, Directional gain = GANT + Array Gain, For PSD measurements on all devices,Array Gain= $10\log(Nant/Nss)$ dB,so directional gain=GANT+Array Gain= $5+10\log(2/2)=5<6$ dBi. So the PSD limit is 11.00 dBm.



U-NII-3

Network Standards	Channel/ Frequency (MHz)	Power Spectral Density					Limit (dBm /MHz)	Conclusion
		Antenna 1		Antenna 2		Total Power (dBm /MHz)		
		Read Value (dBm/MHz)	PSD (dBm /MHz)	Read Value (dBm/MHz)	PSD (dBm /MHz)			
802.11a	149/5745	0.25	1.75	0.38	1.88	4.82	30.00	PASS
	157/5785	0.49	1.99	0.86	2.36	5.19	30.00	PASS
	165/5825	-0.07	1.43	0.68	2.17	4.83	30.00	PASS
802.11n HT20	149/5745	0.94	2.36	0.34	1.76	5.08	30.00	PASS
	157/5785	0.44	1.86	0.76	2.17	5.03	30.00	PASS
	165/5825	0.43	1.85	1.23	2.64	5.28	30.00	PASS
802.11n HT40	151/5755	-2.97	-0.70	-3.38	-1.11	2.11	30.00	PASS
	159/5795	-3.37	-1.09	-2.93	-0.66	2.14	30.00	PASS
802.11ac VHT20	149/5745	-0.08	1.17	0.05	1.30	4.25	30.00	PASS
	157/5785	0.75	2.00	0.06	1.31	4.68	30.00	PASS
	165/5825	0.28	1.53	1.63	2.88	5.26	30.00	PASS
802.11ac VHT40	151/5755	-3.79	-1.03	-2.65	0.12	2.60	30.00	PASS
	159/5795	-4.06	-1.29	-3.41	-0.65	2.05	30.00	PASS
802.11ac VHT80	155/5775	-3.77	-2.68	-3.51	-2.42	0.46	30.00	PASS

Note: 1. Power Spectral Density =Read Value+Duty cycle correction factor
2. For Total PSD, according to KDB 662911 D01 Multiple Transmitter Output v02r01 2)a),the power spectral density= $10\log(10^{(\text{PSD antenna1 in dBm}/10)}+10^{(\text{PSD antenna2 in dBm}/10)})$
3. The manufacturer declared the transmitter output signals is CDD mode And Nss=2. According to KDB 662911 D01 Multiple Transmitter Output v02r01 2)f)(i): If all antennas have the same gain, Directional gain = GANT + Array Gain, For PSD measurements on all devices,Array Gain= $10\log(\text{Nant}/\text{Nss})\text{dB}$,so directional gain=GANT+Array Gain= $5+10\log(2/2)=5<6\text{ dBi}$. So the PSD limit is 30.00 dBm.



SISO Antenna 1:

U-NII-1, 802.11a, Channel No.: 36



U-NII-1, 802.11n HT20, Channel No.: 36



U-NII-1, 802.11a, Channel No.: 40



U-NII-1, 802.11n HT20, Channel No.: 40

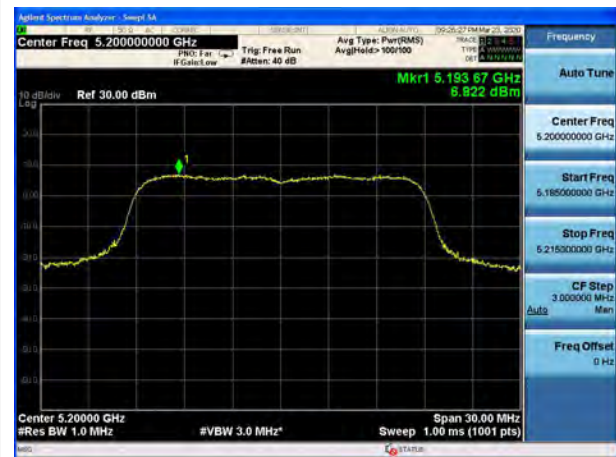

U-NII-1, 802.11a, Channel No.: 48

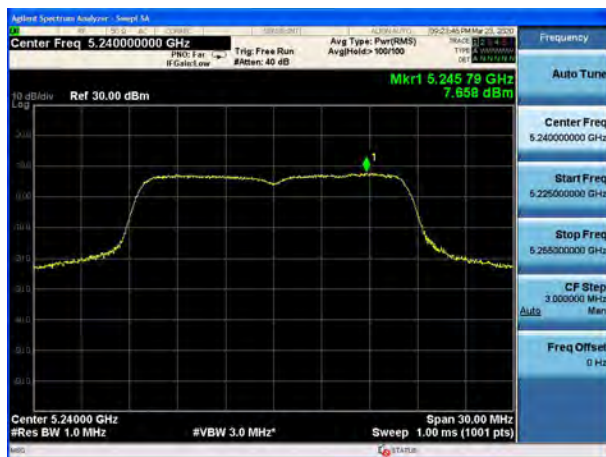

U-NII-1, 802.11n HT20, Channel No.: 48





U-NII-1, 802.11n HT40, Channel No.: 38



U-NII-1, 802.11ac VHT20, Channel No.: 36



U-NII-1, 802.11n HT40, Channel No.: 46



U-NII-1, 802.11ac VHT20, Channel No.: 40



U-NII-1, 802.11ac VHT40, Channel No.: 38

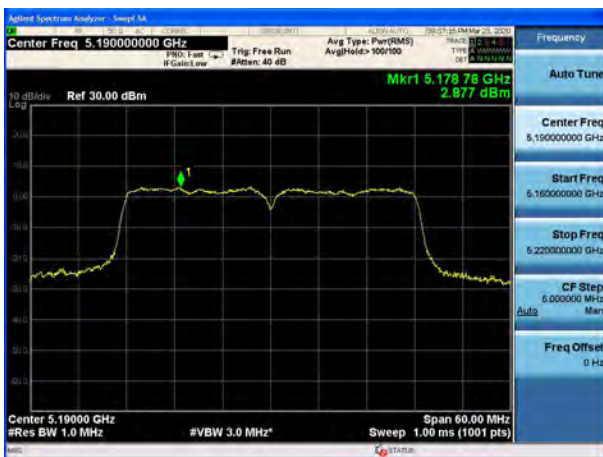

U-NII-1, 802.11ac VHT20, Channel No.: 48

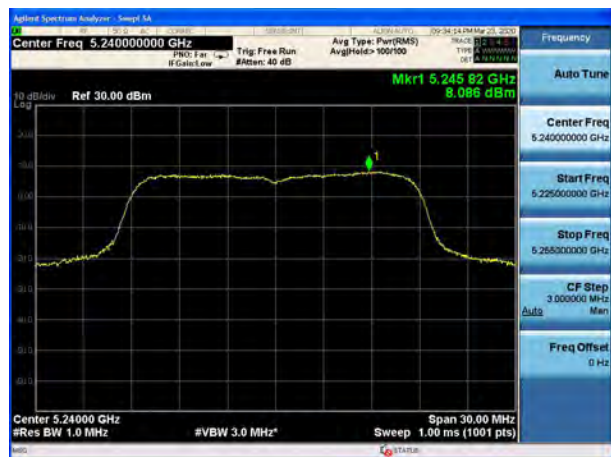

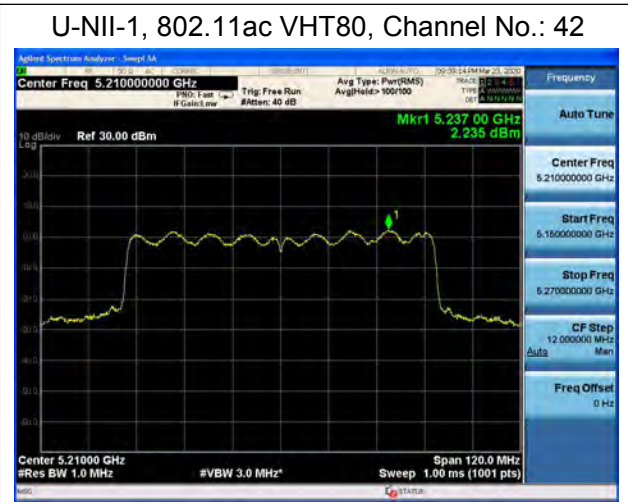
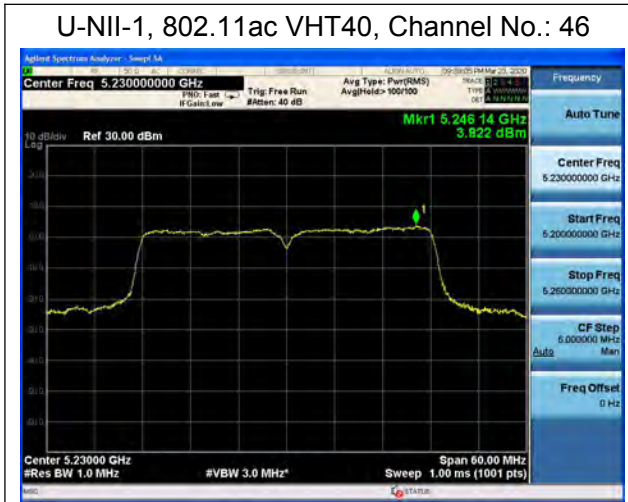



U-NII-3, 802.11a, Channel No.: 149



U-NII-3, 802.11n HT20, Channel No.: 149



U-NII-3, 802.11a, Channel No.: 157



U-NII-3, 802.11n HT20, Channel No.: 157

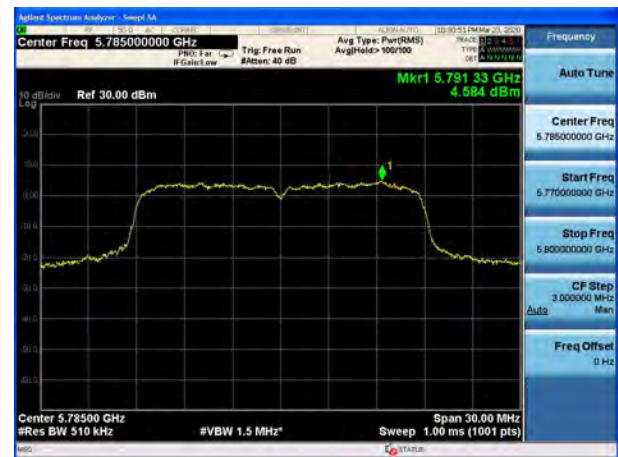

U-NII-3, 802.11a, Channel No.: 165

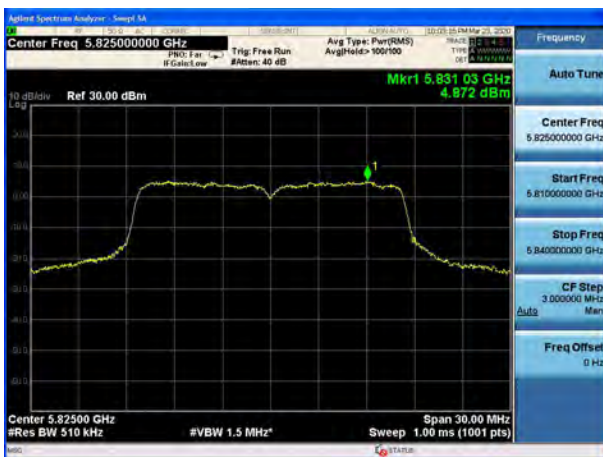

U-NII-3, 802.11n HT20, Channel No.: 165





U-NII-3, 802.11n HT40, Channel No.: 151



U-NII-3, 802.11ac VHT20, Channel No.: 149



U-NII-3, 802.11n HT40, Channel No.: 159



U-NII-3, 802.11ac VHT20, Channel No.: 157

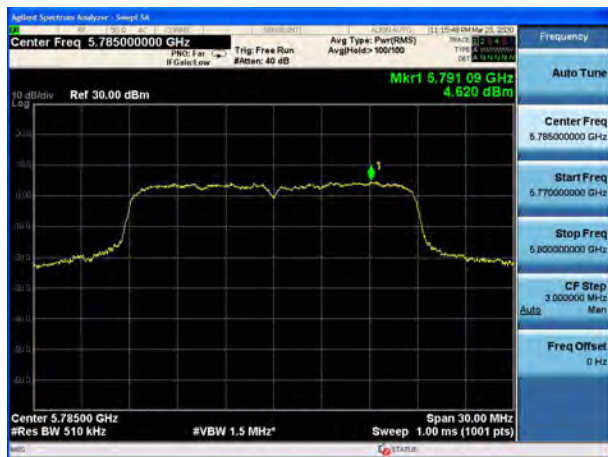

U-NII-3, 802.11ac VHT40, Channel No.: 151



U-NII-3, 802.11ac VHT20, Channel No.: 165

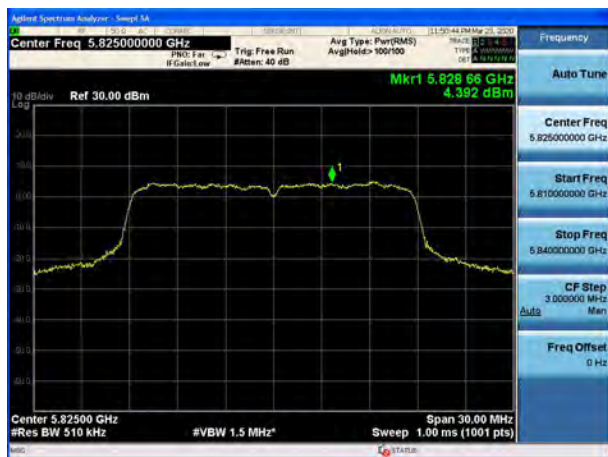

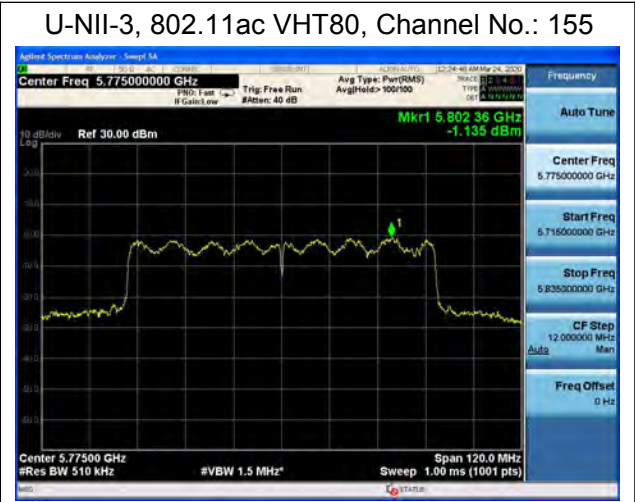
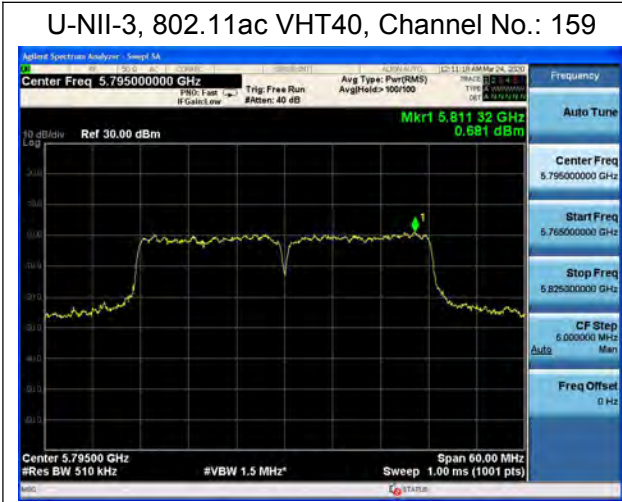



SISO Antenna 2:

U-NII-1, 802.11a, Channel No.: 36



U-NII-1, 802.11n HT20, Channel No.: 36

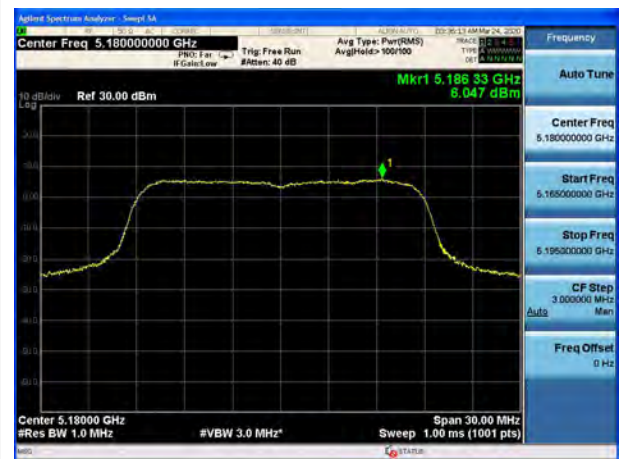

U-NII-1, 802.11a, Channel No.: 40

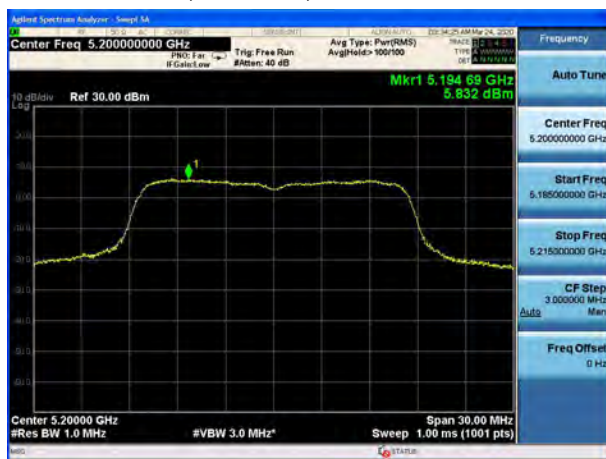

U-NII-1, 802.11n HT20, Channel No.: 40



U-NII-1, 802.11a, Channel No.: 48



U-NII-1, 802.11n HT20, Channel No.: 48

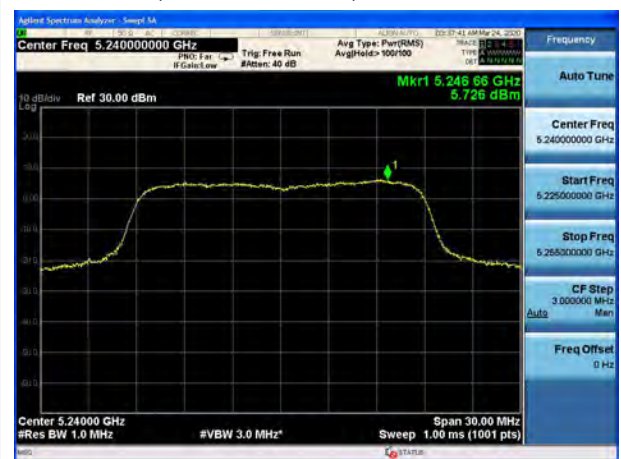



U-NII-1, 802.11n HT40, Channel No.: 38



U-NII-1, 802.11ac VHT20, Channel No.: 36



U-NII-1, 802.11n HT40, Channel No.: 46

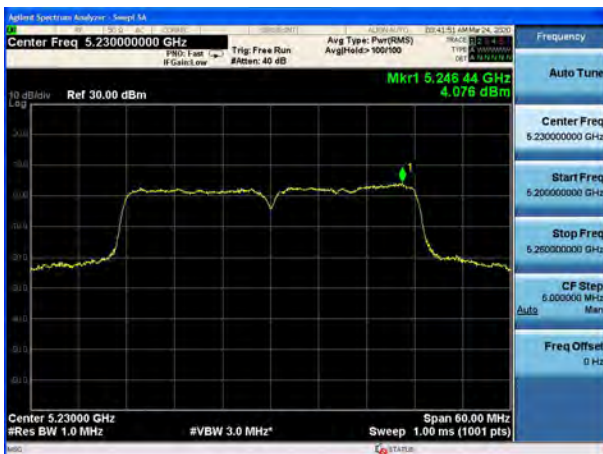

U-NII-1, 802.11ac VHT20, Channel No.: 40



U-NII-1, 802.11ac VHT40, Channel No.: 38



U-NII-1, 802.11ac VHT20, Channel No.: 48

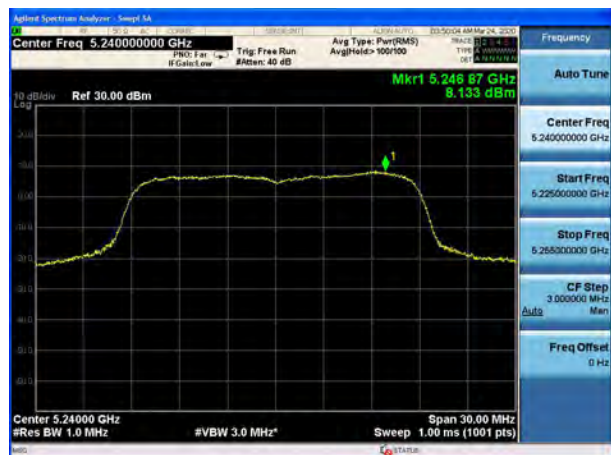

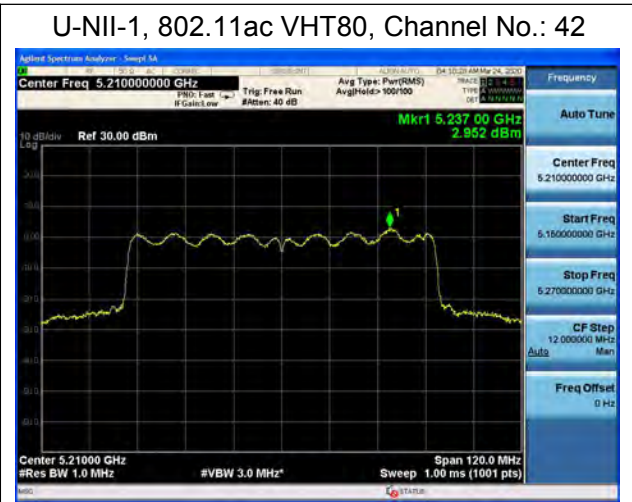
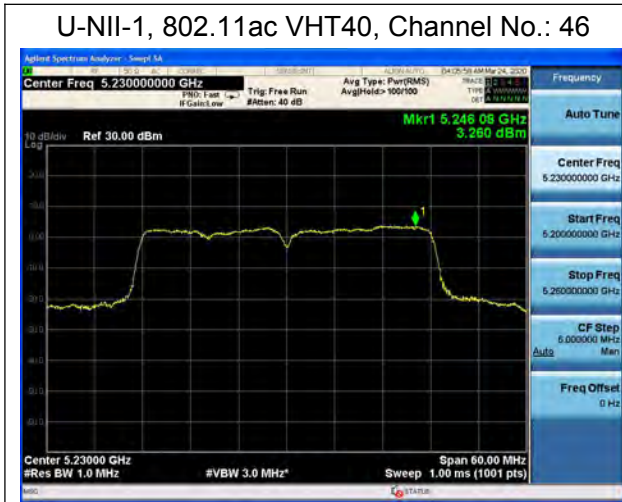



U-NII-3, 802.11a, Channel No.: 149

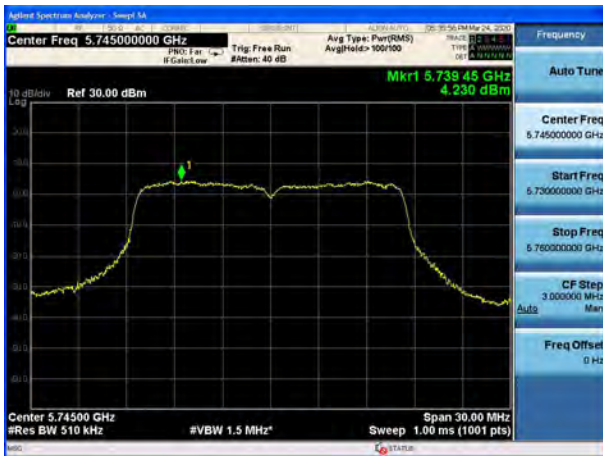

U-NII-3, 802.11n HT20, Channel No.: 149

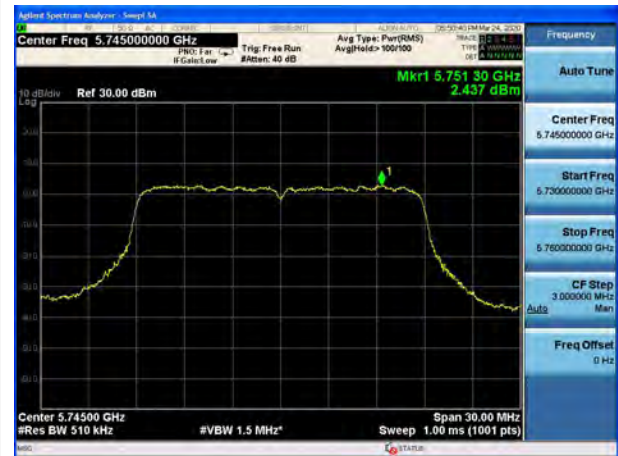

U-NII-3, 802.11a, Channel No.: 157

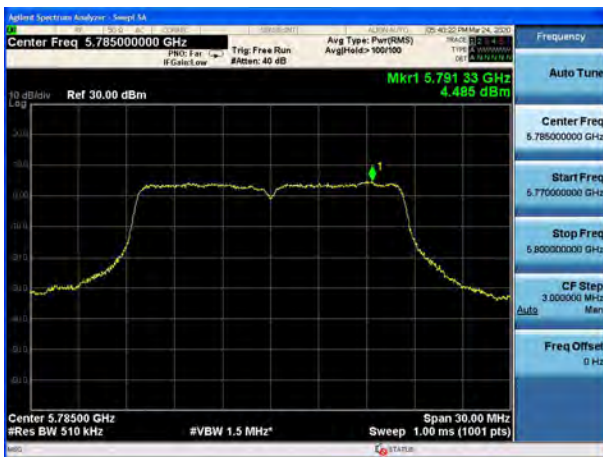

U-NII-3, 802.11n HT20, Channel No.: 157

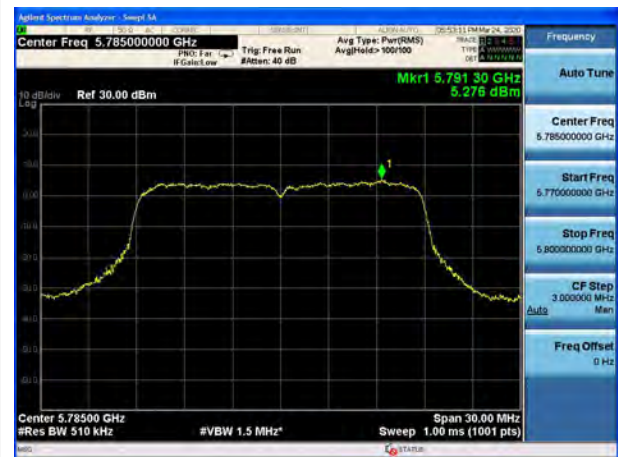

U-NII-3, 802.11a, Channel No.: 165

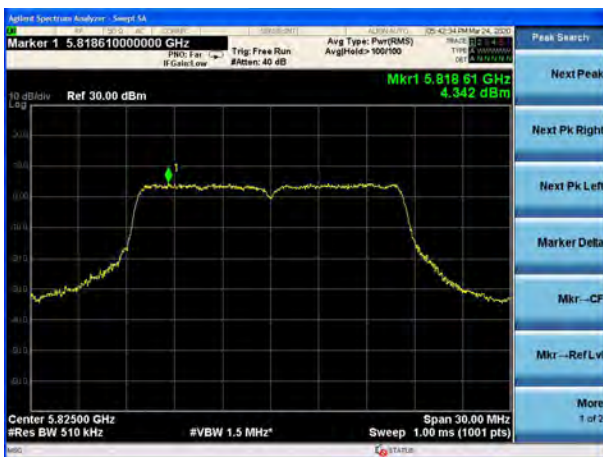

U-NII-3, 802.11n HT20, Channel No.: 165





U-NII-3, 802.11n HT40, Channel No.: 151



U-NII-3, 802.11ac VHT20, Channel No.: 149



U-NII-3, 802.11n HT40, Channel No.: 159



U-NII-3, 802.11ac VHT20, Channel No.: 157



U-NII-3, 802.11ac VHT40, Channel No.: 151

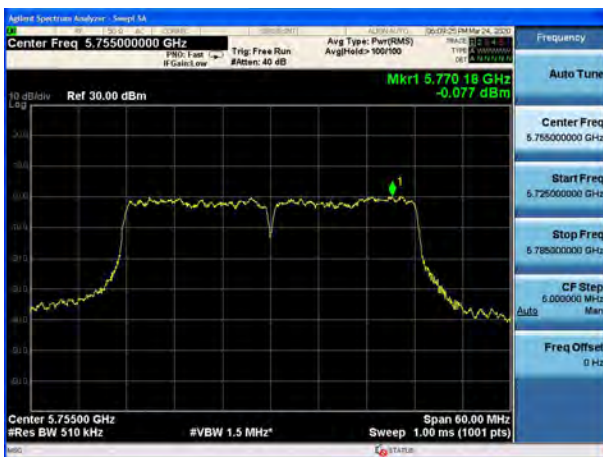

U-NII-3, 802.11ac VHT20, Channel No.: 165



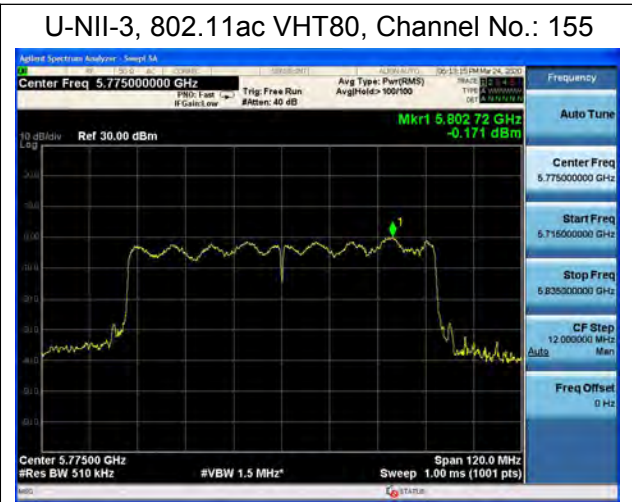
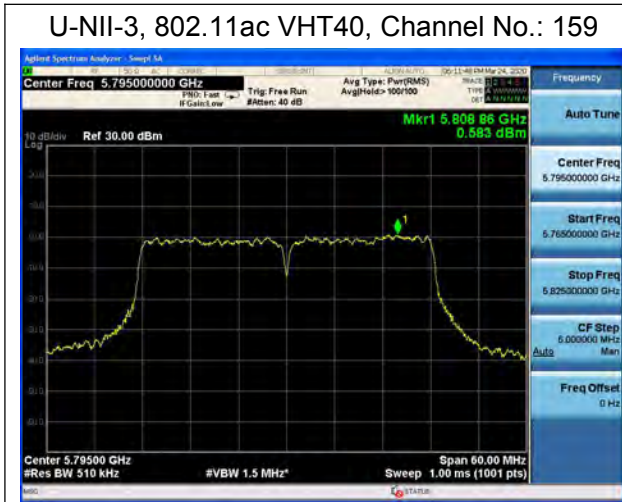



MIMO Antenna 1:

U-NII-1, 802.11a, Channel No.: 36

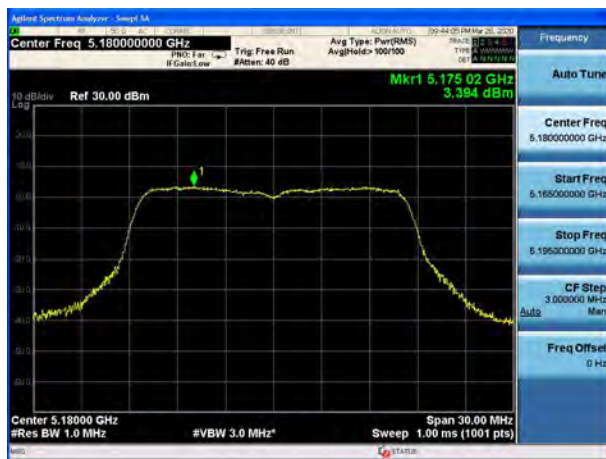

U-NII-1, 802.11n HT20, Channel No.: 36

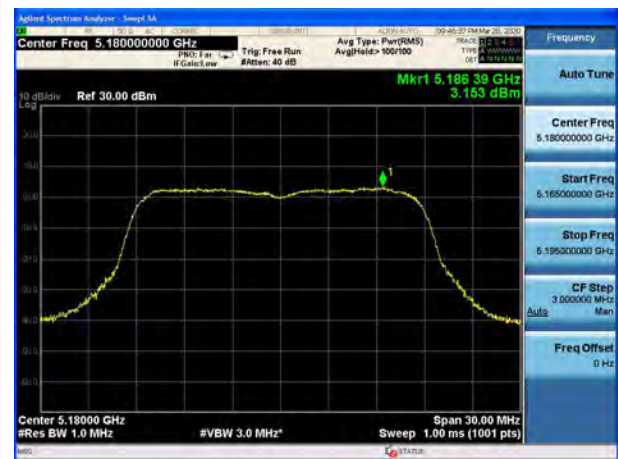

U-NII-1, 802.11a, Channel No.: 40

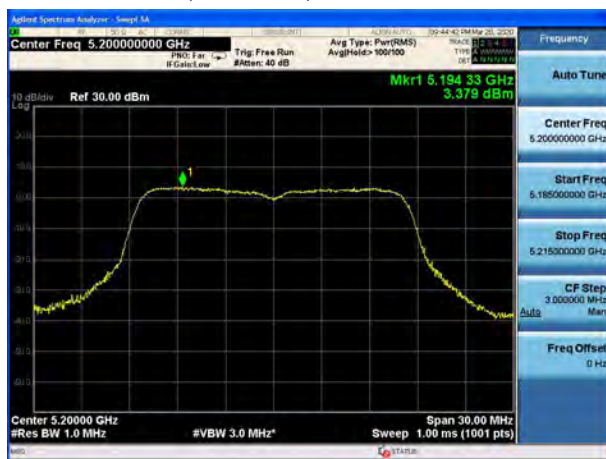

U-NII-1, 802.11n HT20, Channel No.: 40

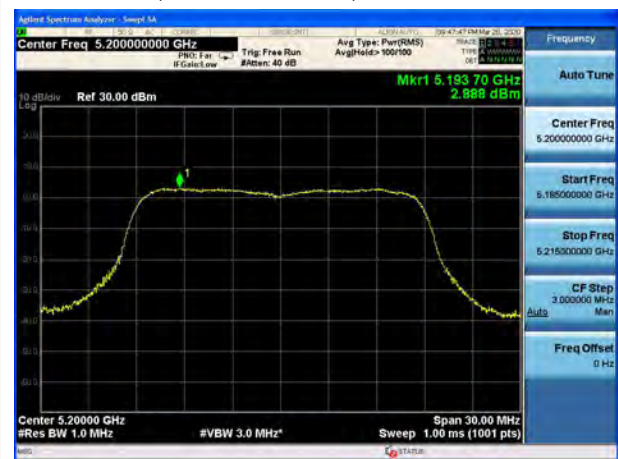

U-NII-1, 802.11a, Channel No.: 48

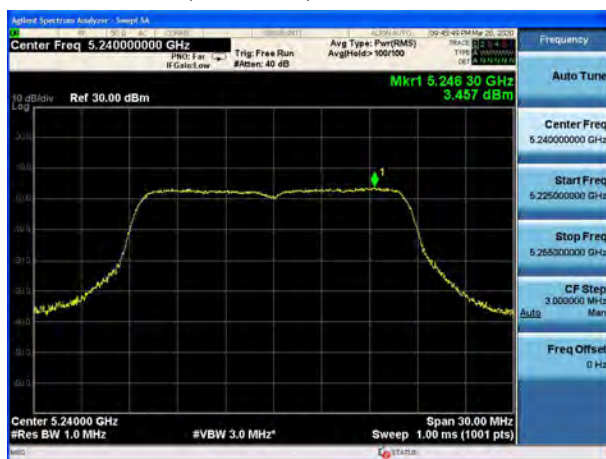

U-NII-1, 802.11n HT20, Channel No.: 48

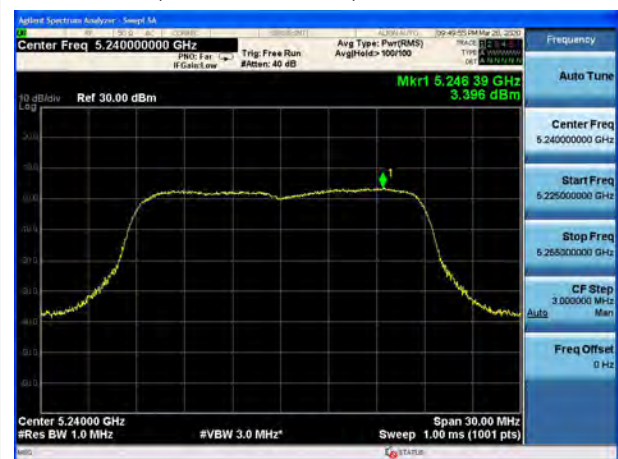

U-NII-1, 802.11n HT40, Channel No.: 38



U-NII-1, 802.11ac VHT20, Channel No.: 36



U-NII-1, 802.11n HT40, Channel No.: 46

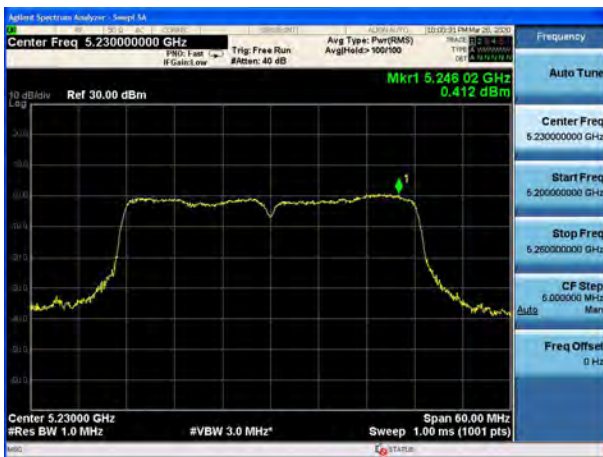

U-NII-1, 802.11ac VHT20, Channel No.: 40



U-NII-1, 802.11ac VHT40, Channel No.: 38

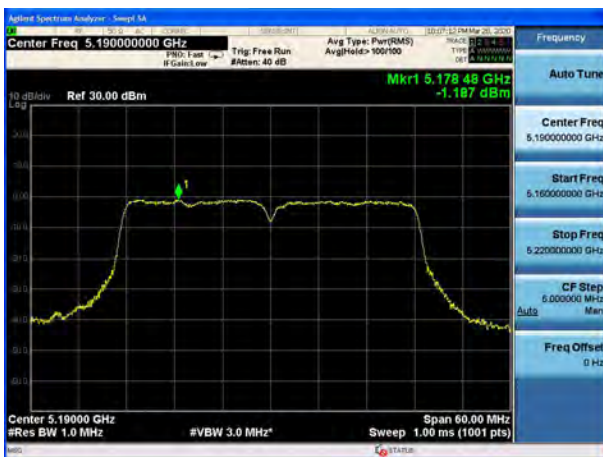

U-NII-1, 802.11ac VHT20, Channel No.: 48

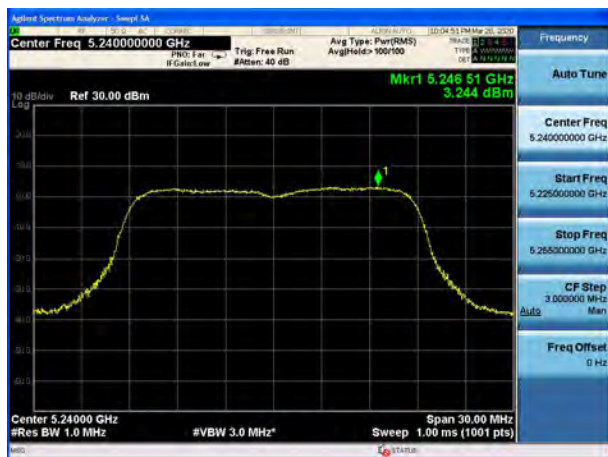



U-NII-1, 802.11ac VHT40, Channel No.: 46

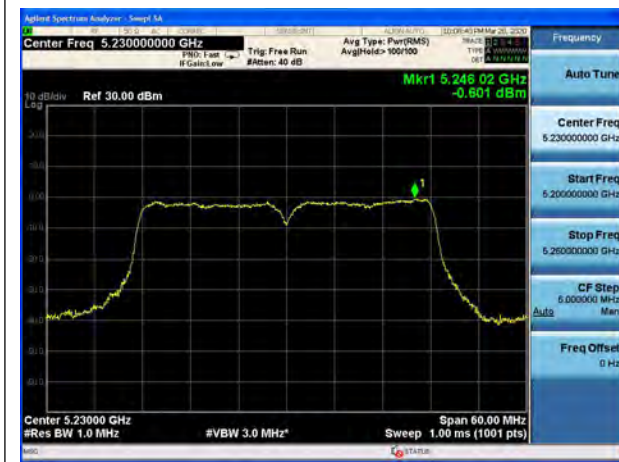

U-NII-1, 802.11ac VHT80, Channel No.: 42





U-NII-3, 802.11a, Channel No.: 149

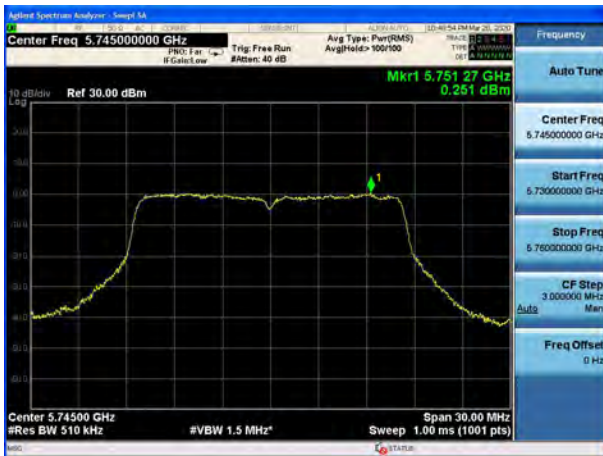

U-NII-3, 802.11n HT20, Channel No.: 149



U-NII-3, 802.11a, Channel No.: 157

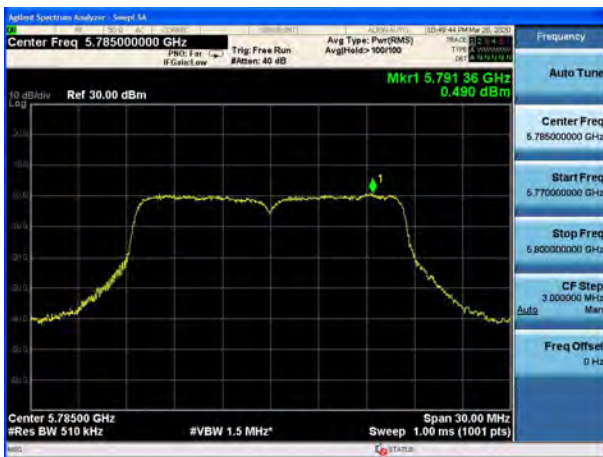

U-NII-3, 802.11n HT20, Channel No.: 157

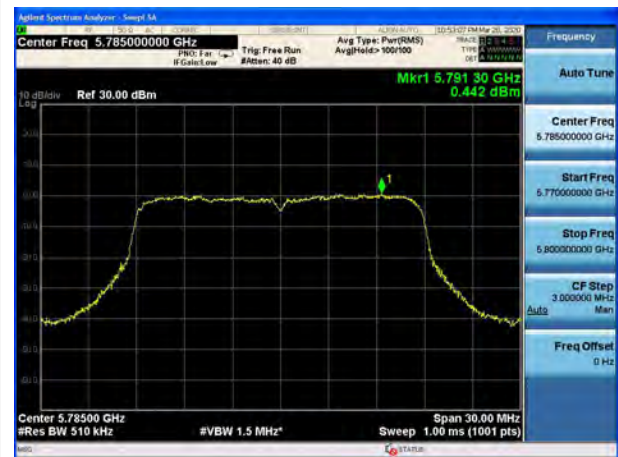

U-NII-3, 802.11a, Channel No.: 165



U-NII-3, 802.11n HT20, Channel No.: 165

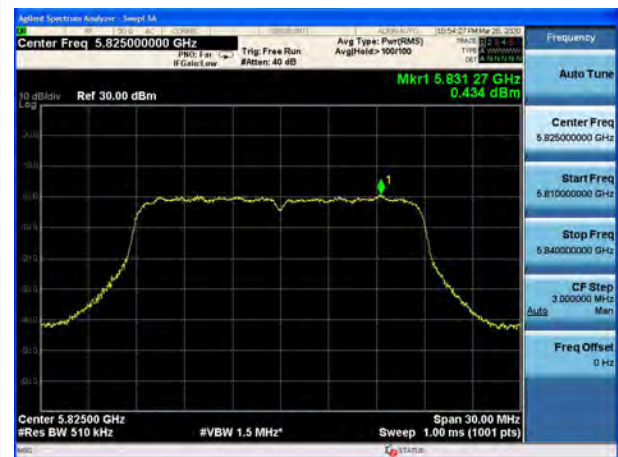



U-NII-3, 802.11n HT40, Channel No.: 151



U-NII-3, 802.11ac VHT20, Channel No.: 149



U-NII-3, 802.11n HT40, Channel No.: 159



U-NII-3, 802.11ac VHT20, Channel No.: 157

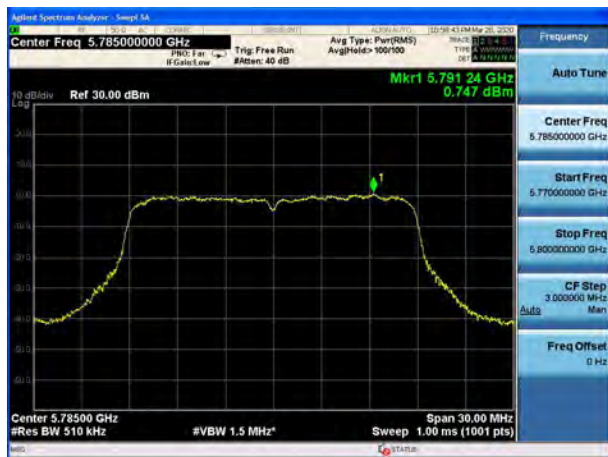

U-NII-3, 802.11ac VHT40, Channel No.: 151

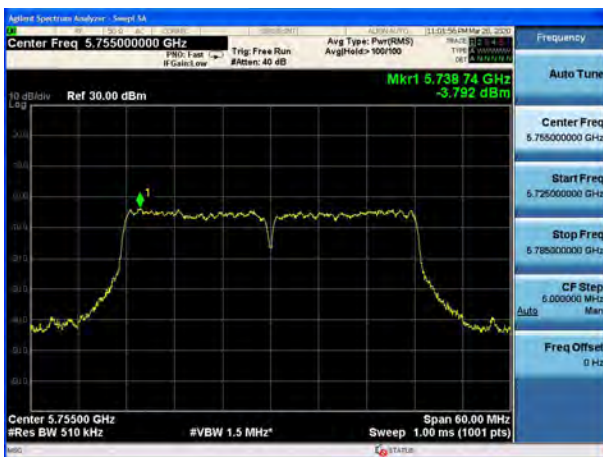

U-NII-3, 802.11ac VHT20, Channel No.: 165

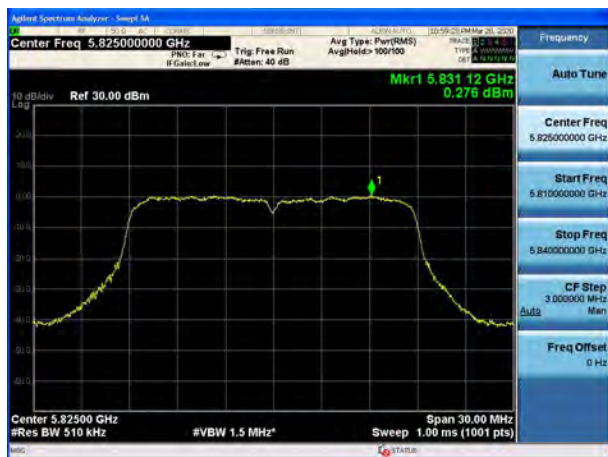

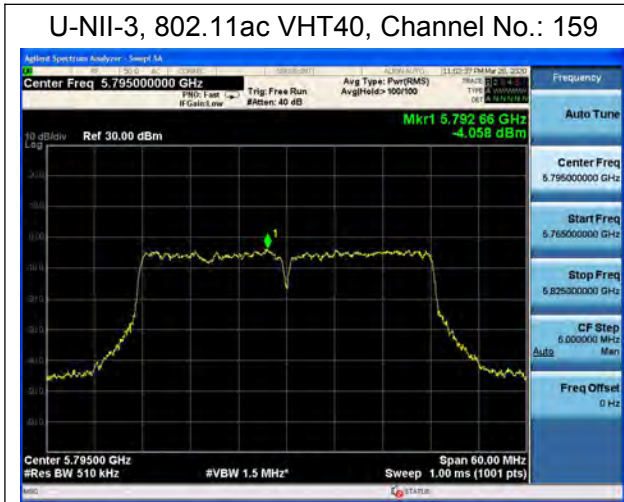



MIMO Antenna 2:

U-NII-1, 802.11a, Channel No.: 36

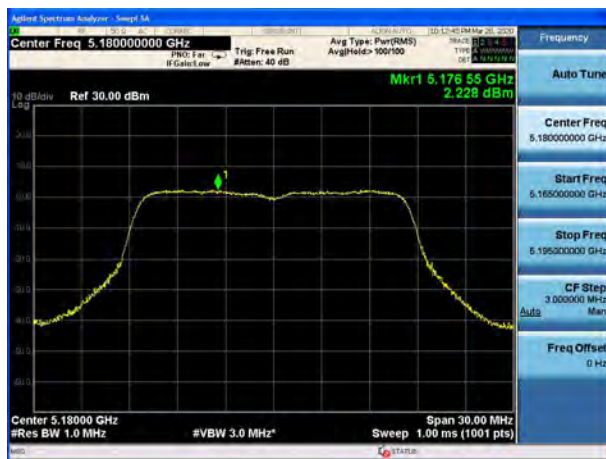

U-NII-1, 802.11n HT20, Channel No.: 36

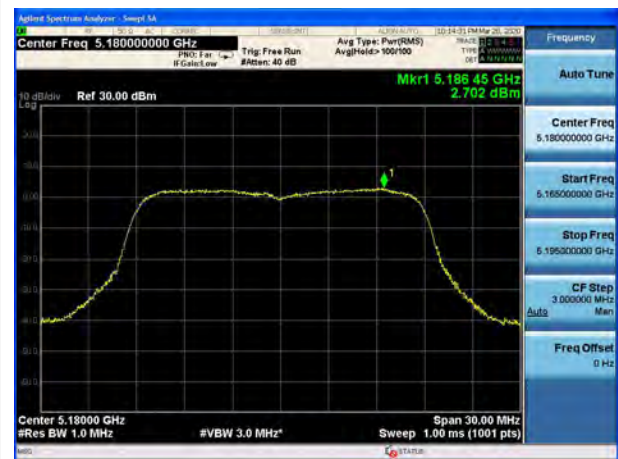

U-NII-1, 802.11a, Channel No.: 40



U-NII-1, 802.11n HT20, Channel No.: 40



U-NII-1, 802.11a, Channel No.: 48

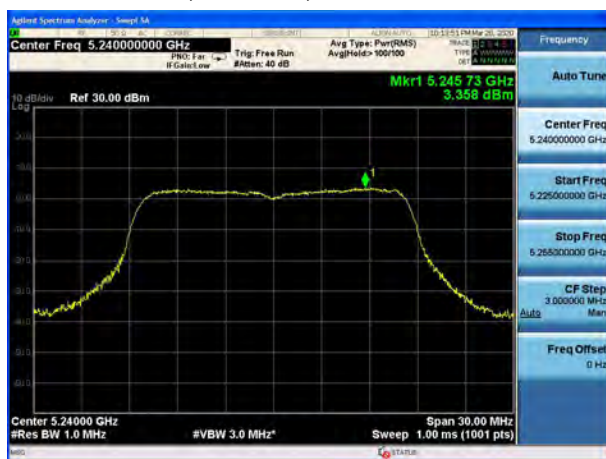

U-NII-1, 802.11n HT20, Channel No.: 48

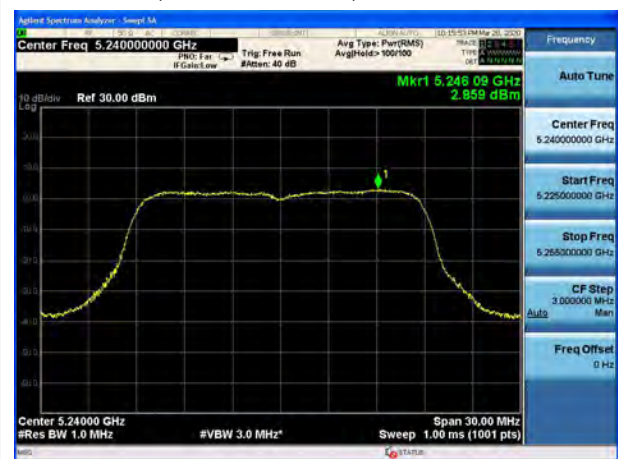



U-NII-1, 802.11n HT40, Channel No.: 38



U-NII-1, 802.11ac VHT20, Channel No.: 36

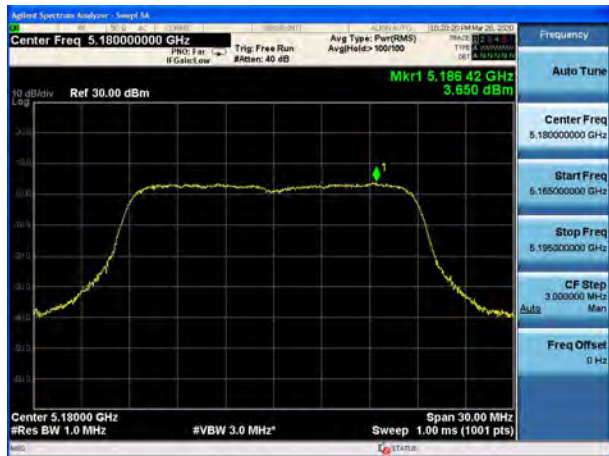

U-NII-1, 802.11n HT40, Channel No.: 46



U-NII-1, 802.11ac VHT20, Channel No.: 40



U-NII-1, 802.11ac VHT40, Channel No.: 38

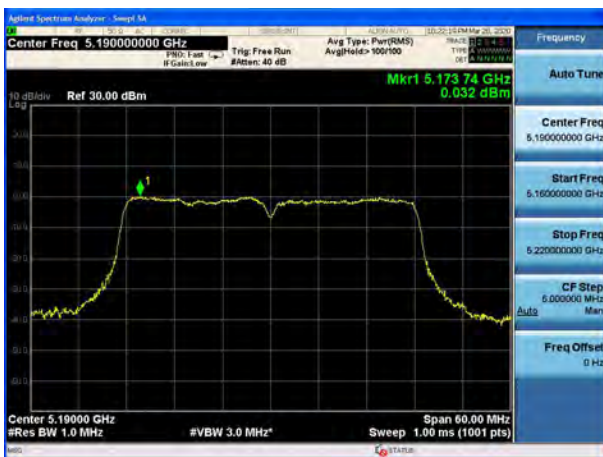

U-NII-1, 802.11ac VHT20, Channel No.: 48

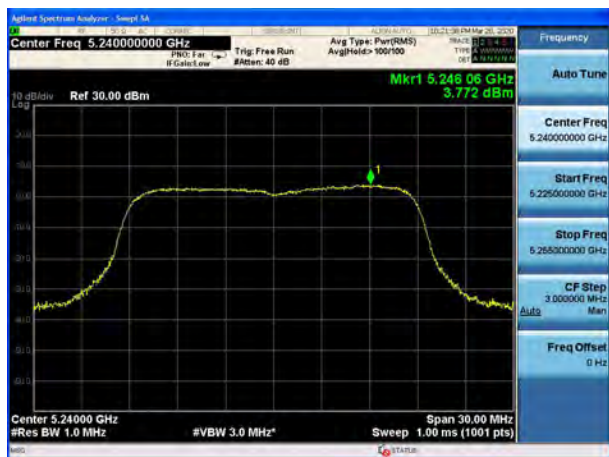

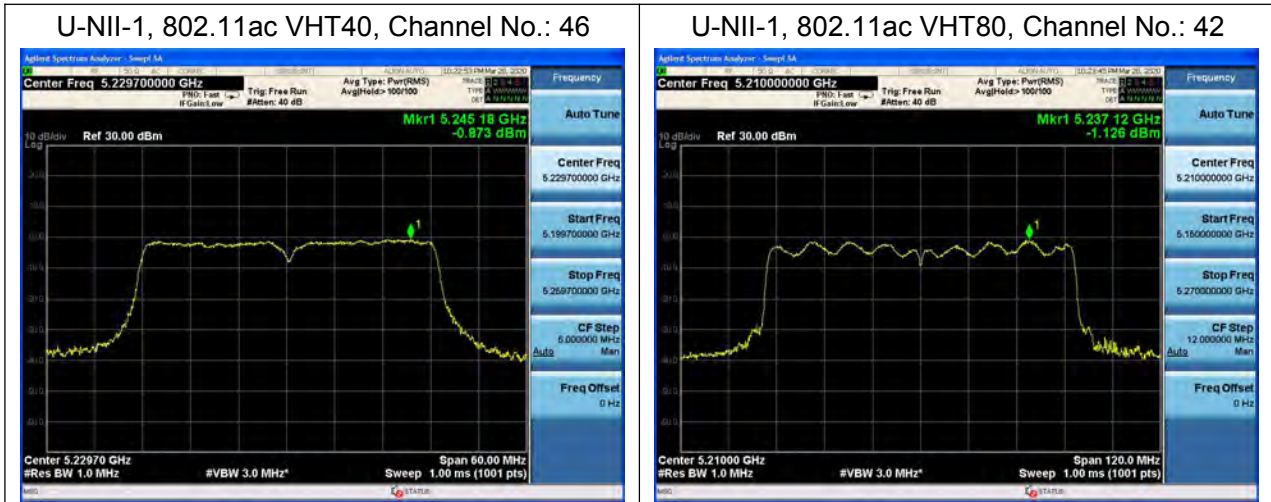



U-NII-3, 802.11a, Channel No.: 149



U-NII-3, 802.11n HT20, Channel No.: 149

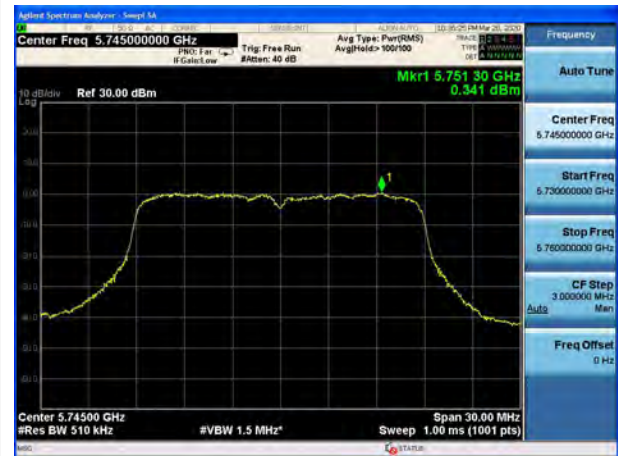

U-NII-3, 802.11a, Channel No.: 157

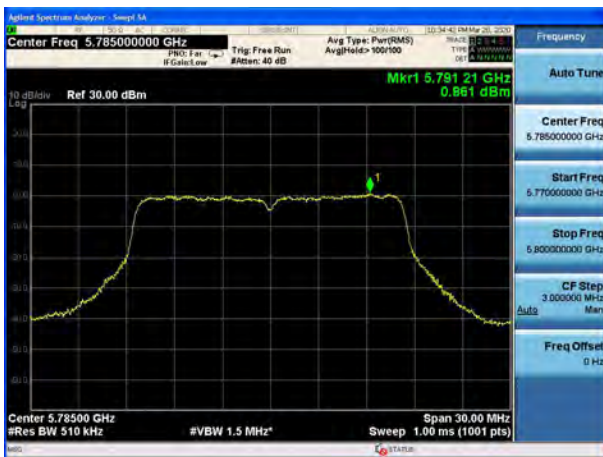

U-NII-3, 802.11n HT20, Channel No.: 157

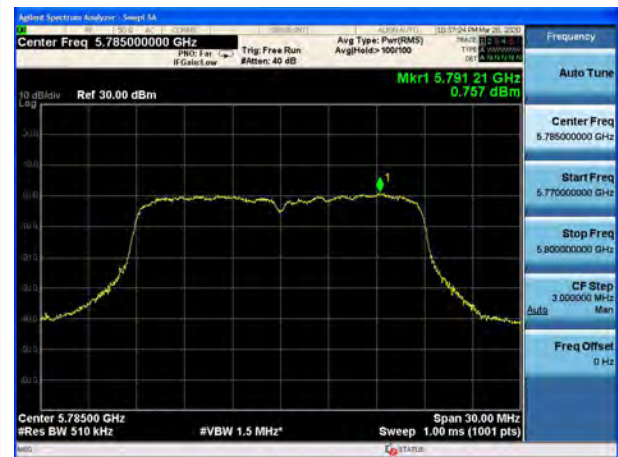

U-NII-3, 802.11a, Channel No.: 165

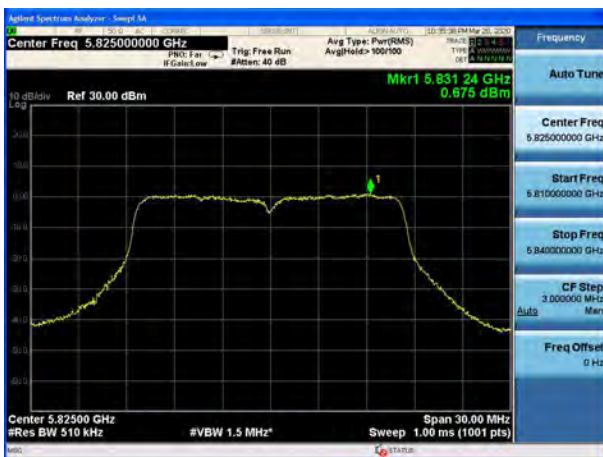

U-NII-3, 802.11n HT20, Channel No.: 165

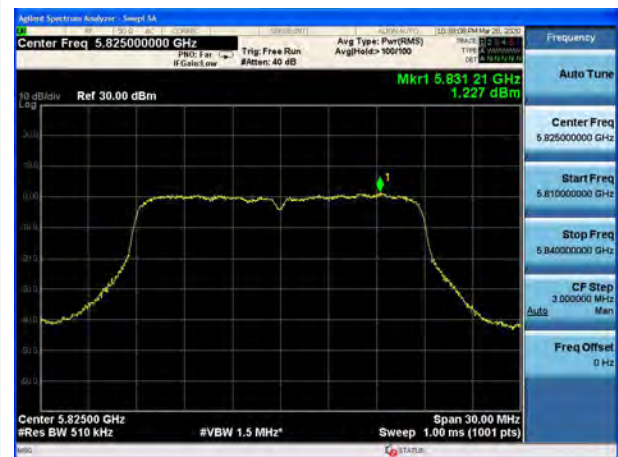



U-NII-3, 802.11n HT40, Channel No.: 151



U-NII-3, 802.11ac VHT20, Channel No.: 149

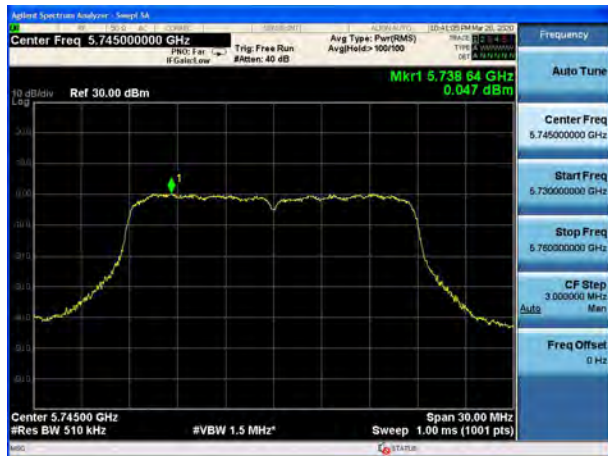

U-NII-3, 802.11n HT40, Channel No.: 159



U-NII-3, 802.11ac VHT20, Channel No.: 157



U-NII-3, 802.11ac VHT40, Channel No.: 151

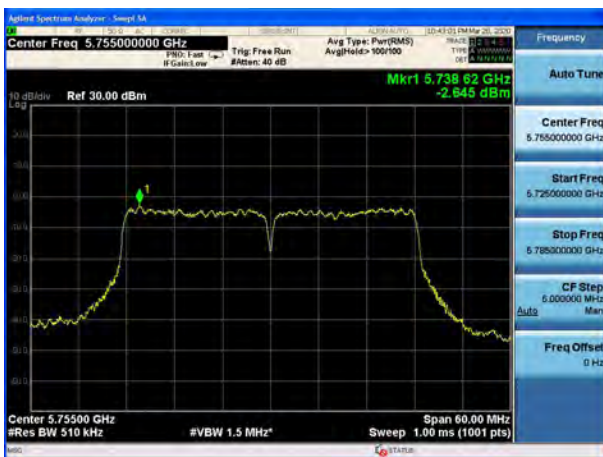

U-NII-3, 802.11ac VHT20, Channel No.: 165

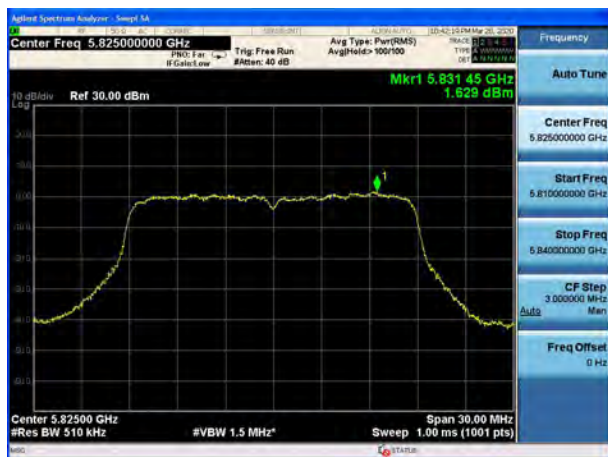

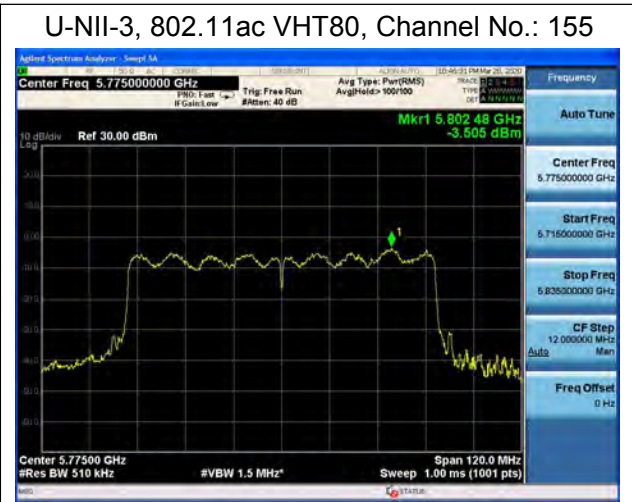
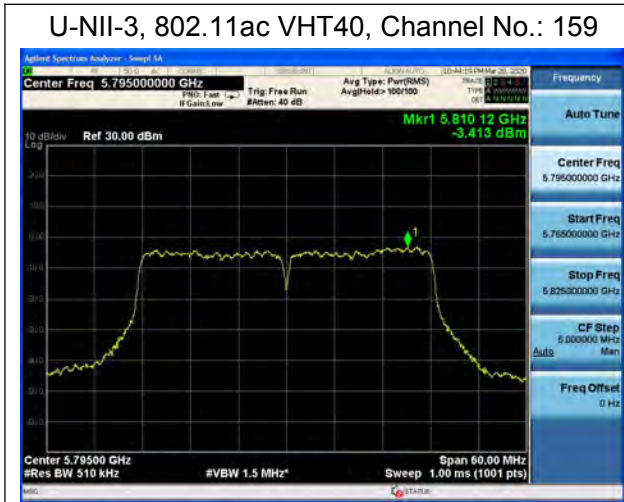



5.5. Unwanted Emission

Ambient condition

Temperature	Relative humidity	Pressure
23°C ~25°C	45%~50%	101.5kPa

Method of Measurement

The test set-up was made in accordance to the general provisions of ANSI C63.10-2013. The Equipment Under Test (EUT) was set up on a non-conductive table in the semi-anechoic chamber. The test was performed at the distance of 3 m between the EUT and the receiving antenna. The radiated emissions measurements were made in a typical installation configuration. Sweep the whole frequency band range from 9kHz to the 10th harmonic of the carrier, and the emissions less than 20 dB below the permissible value are reported.

During the test, the height of receive antenna shall be moved from 1 to 4 meters, and the antenna shall be performed under horizontal and vertical polarization. The turntable shall be rotated from 0 to 360 degrees for detecting the maximum of radiated spurious signal level. The measurements shall be repeated with orthogonal polarization of the test antenna. The data of cable loss and antenna factor has been calibrated in full testing frequency range before the testing.

Set the spectrum analyzer in the following:

Below 1GHz (detector: Peak and Quasi-Peak)

RBW=100kHz / VBW=300kHz / Sweep=AUTO

Above 1GHz (detector: Peak):

I) Peak emission levels are measured by setting the instrument as follows:

- 1) RBW = 1 MHz.
- 2) VBW \geq [3 × RBW]
- 3) Detector = peak.
- 4) Sweep time = auto.
- 5) Trace mode = max hold.
- 6) Allow sweeps to continue until the trace stabilizes. Note that if the transmission is not continuous, then the time required for the trace to stabilize will increase by a factor of approximately 1 / D, where D is the duty cycle.

II) Average emission levels are measured by setting the instrument as follows:

- a) RBW = 1 MHz.
- b) VBW \geq [3 × RBW].
- c) Detector = RMS (power averaging), if [span / (# of points in sweep)] \leq RBW / 2. Satisfying this condition can require increasing the number of points in the sweep or reducing the span. If the condition is not satisfied, then the detector mode shall be set to peak.
- d) Averaging type = power (i.e., rms) (As an alternative, the detector and averaging type may be set for linear voltage averaging. Some instruments require linear display mode to use linear voltage averaging. Log or dB averaging shall not be used.)

- e) Sweep time = auto.
- f) Perform a trace average of at least 100 traces if the transmission is continuous. If the transmission is not continuous, then the number of traces shall be increased by a factor of $1 / D$, where D is the duty cycle. For example, with 50% duty cycle, at least 200 traces shall be averaged. (If a specific emission is demonstrated to be continuous—i.e., 100% duty cycle—then rather than turning ON and OFF with the transmit cycle, at least 100 traces shall be averaged.)
- g) If tests are performed with the EUT transmitting at a duty cycle less than 98%, then a correction factor shall be added to the measurement results prior to comparing with the emission limit, to compute the emission level that would have been measured had the test been performed at 100% duty cycle. The correction factor is computed as follows:
 - 1) If power averaging (rms) mode was used in the preceding step e), then the correction factor is $[10 \log (1 / D)]$, where D is the duty cycle. For example, if the transmit duty cycle was 50%, then 3 dB shall be added to the measured emission levels.
 - 2) If linear voltage averaging mode was used in the preceding step e), then the correction factor is $[20 \log (1 / D)]$, where D is the duty cycle. For example, if the transmit duty cycle was 50%, then 6 dB shall be added to the measured emission levels.
 - 3) If a specific emission is demonstrated to be continuous (100% duty cycle) rather than turning ON and OFF with the transmit cycle, then no duty cycle correction is required for that emission.

Reduce the video bandwidth until no significant variations in the displayed signal are observed in subsequent traces, provided the video bandwidth is no less than 1 Hz. For regulatory requirements that specify averaging only over the transmit duration (e.g., digital transmission system [DTS] and Unlicensed National Information Infrastructure [U-NII]), the video bandwidth shall be greater than $[1 / (\text{minimum transmitter on time})]$ and no less than 1 Hz.

The field strength of spurious emission was measured in the following position: EUT stand-up position (Z axis), lie-down position (X, Y axis). The worst emission was found in stand-up position (Z axis) and the loop antenna is vertical, others antenna are vertical and horizontal.

The test is in transmitting mode.

30MHz~~~ 1GHz

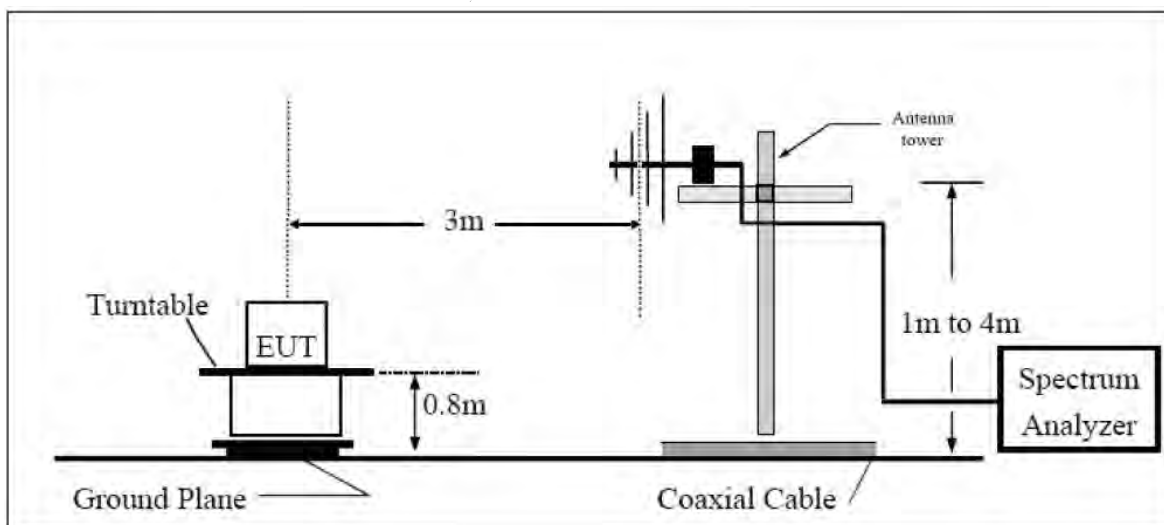

Above 1GHz

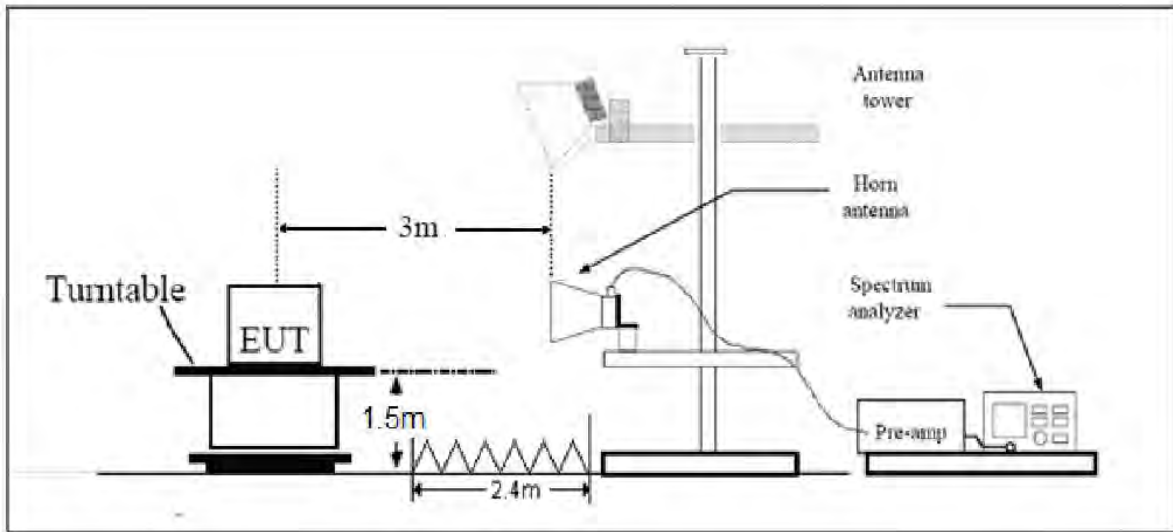

Note: Area side:2.4mX3.6m

**Limits**

- (1) For transmitters operating in the 5725-5850 MHz band: All emissions shall be limited to a level of -27 dBm/MHz at 75 MHz or more above or below the band edge increasing linearly to 10 dBm/MHz at 25 MHz above or below the band edge, and from 25 MHz above or below the band edge increasing linearly to a level of 15.6 dBm/MHz at 5 MHz above or below the band edge, and from 5 MHz above or below the band edge increasing linearly to a level of 27 dBm/MHz at the band edge.
- (2) For transmitters operating in the 5.15-5.25 GHz band: All emissions outside of the 5.15-5.35 GHz band shall not exceed an e.i.r.p. of -27 dBm/MHz(68.2dBμV/m).

Note: the following formula is used to convert the EIRP to field strength

§1、 $E[\text{dB}\mu\text{V}/\text{m}] = \text{EIRP}[\text{dBm}] - 20 \log(d[\text{meters}]) + 104.77$, where E = field strength and

d = distance at which field strength limit is specified in the rules;

§2、 $E[\text{dB}\mu\text{V}/\text{m}] = \text{EIRP}[\text{dBm}] + 95.2$, for d = 3 meters

- (3) Unwanted spurious emissions fallen in restricted bands per FCC Part15.205 shall comply with the general field strength limits set forth in § 15.209 as below table.

Frequency of emission (MHz)	Field strength(uV/m)	Field strength(dBuV/m)
0.009–0.490	2400/F(kHz)	/
0.490–1.705	24000/F(kHz)	/
1.705–30.0	30	/
30-88	100	40
88-216	150	43.5
216-960	200	46
Above960	500	54



MHz	MHz	MHz	GHz
0.090 - 0.110	16.42 - 16.423	399.9 - 410	4.5 - 5.15
0.495 - 0.505	16.69475 - 16.69525	608 - 614	5.35 - 5.46
2.1735 - 2.1905	16.80425 - 16.80475	960 - 1240	7.25 - 7.75
4.125 - 4.128	25.5 - 25.67	1300 - 1427	8.025 - 8.5
4.17725 - 4.17775	37.5 - 38.25	1435 - 1626.5	9.0 - 9.2
4.20725 - 4.20775	73 - 74.6	1645.5 - 1646.5	9.3 - 9.5
6.215 - 6.218	74.8 - 75.2	1660 - 1710	10.6 - 12.7
6.26775 - 6.26825	108 - 121.94	1718.8 - 1722.2	13.25 - 13.4
6.31175 - 6.31225	123 - 138	2200 - 2300	14.47 - 14.5
8.291 - 8.294	149.9 - 150.05	2310 - 2390	15.35 - 16.2
8.362 - 8.366	156.52475 - 156.52525	2483.5 - 2500	17.7 - 21.4
8.37625 - 8.38675	156.7 - 156.9	2690 - 2900	22.01 - 23.12
8.41425 - 8.41475	162.0125 - 167.17	3260 - 3267	23.6 - 24.0
12.29 - 12.293	167.72 - 173.2	3332 - 3339	31.2 - 31.8
12.51975 - 12.52025	240 - 285	3345.8 - 3358	36.43 - 36.5
12.57675 - 12.57725	322 - 335.4	3600 - 4400	(²)
13.36 - 13.41			

Measurement Uncertainty

The assessed measurement uncertainty to ensure 95% confidence level for the normal distribution is with the coverage factor $k = 1.96$.

Frequency	Uncertainty
9KHz-30MHz	3.55 dB
30MHz-200MHz	4.02 dB
200MHz-1GHz	3.28 dB
1GHz-18G	3.70 dB
18GHz-26.5GHz	5.78 dB
26.5G-40GHz	5.82 dB



Test Results:

The modulation and bandwidth are similar for 802.11n mode for 20MHz/40MHz and 802.11ac mode for V20MHz/V40MHz, therefore investigated worst case to representative mode in test report.

The signal beyond the limit is carrier.

MIMO:

U-NII-1

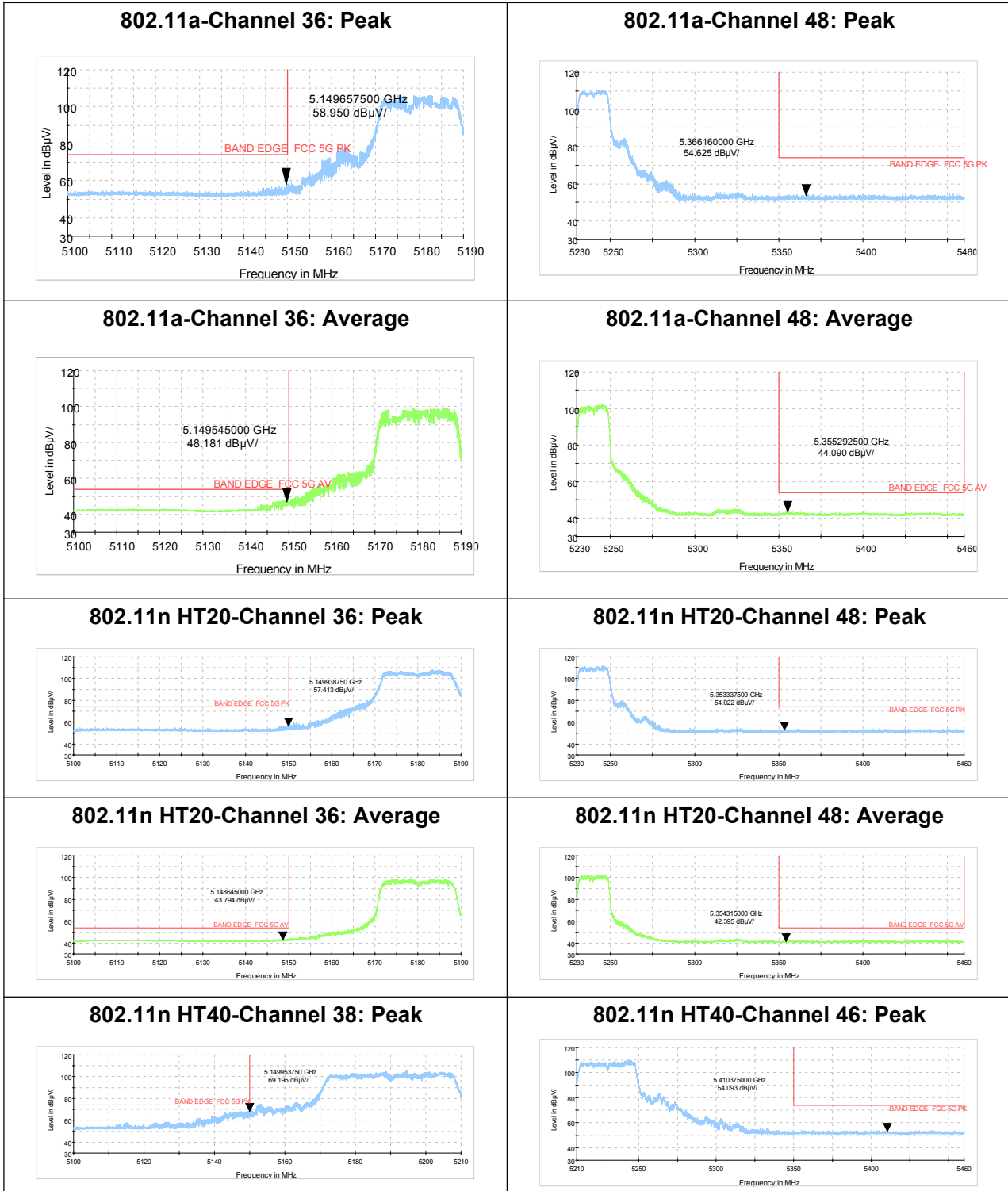



802.11n HT40-Channel 38: Average

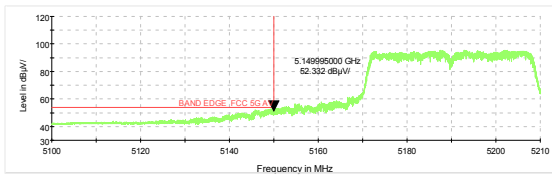

802.11n HT40-Channel 46: Average

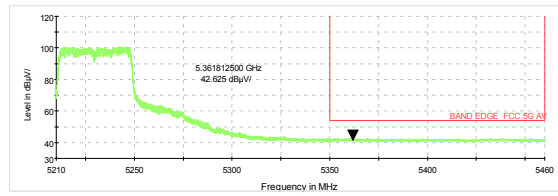

802.11ac VHT80 -Channel 42: Peak

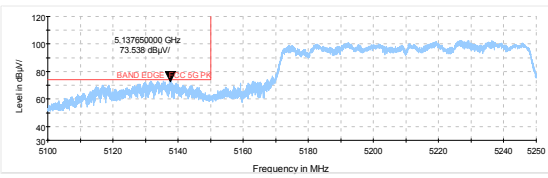

802.11ac VHT80- Channel 42: Average

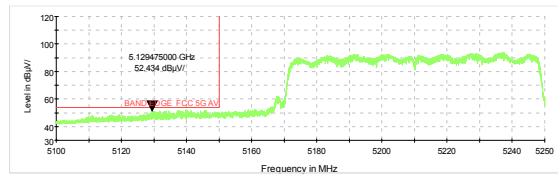



U-NII-3

802.11a-Channel 149: Peak

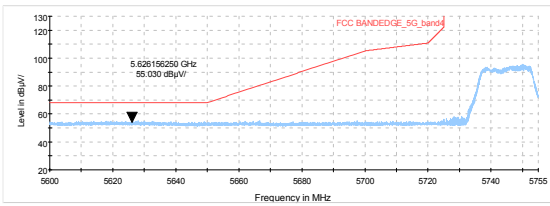

802.11a-Channel 165: Peak

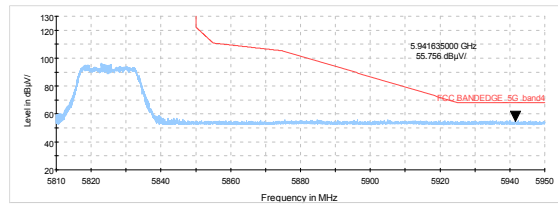

802.11n HT20-Channel 149: Peak

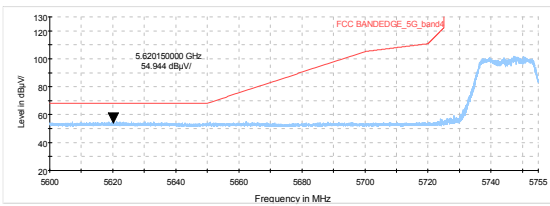

802.11n HT20-Channel 165: Peak

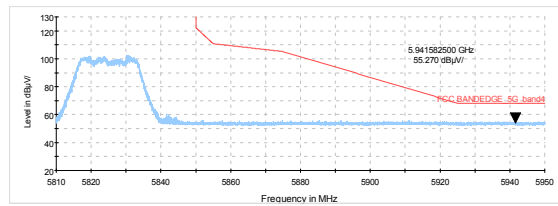

802.11n HT40-Channel 151: Peak

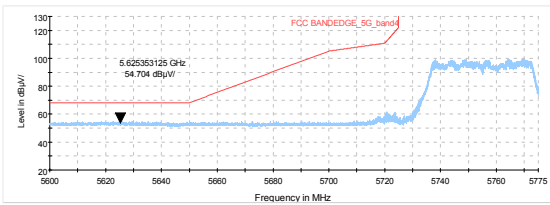

802.11n HT40-Channel 159: Peak

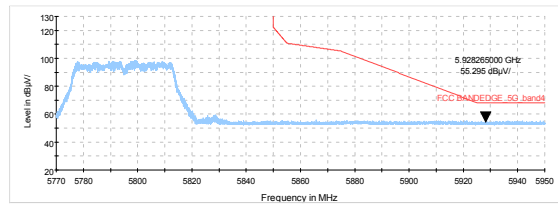

802.11ac VHT80- Channel 155: Peak

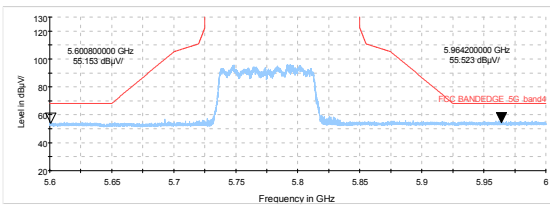

**Result of RE****Test result**

Sweep the whole frequency band through the range from 9kHz to the 10th harmonic of the carrier, the Emissions in the frequency band 9kHz-30MHz and 26.5GHz-40GHz are more than 20dB below the limit are not reported.

After the pretest, MIMO was selected as the worst antenna.

During the test, the Radiates Emission from 30MHz to 1GHz was performed in all modes with all channels, 802.11ac HT40, Channel 38 are selected as the worst condition. The test data of the worst-case condition was recorded in this report.

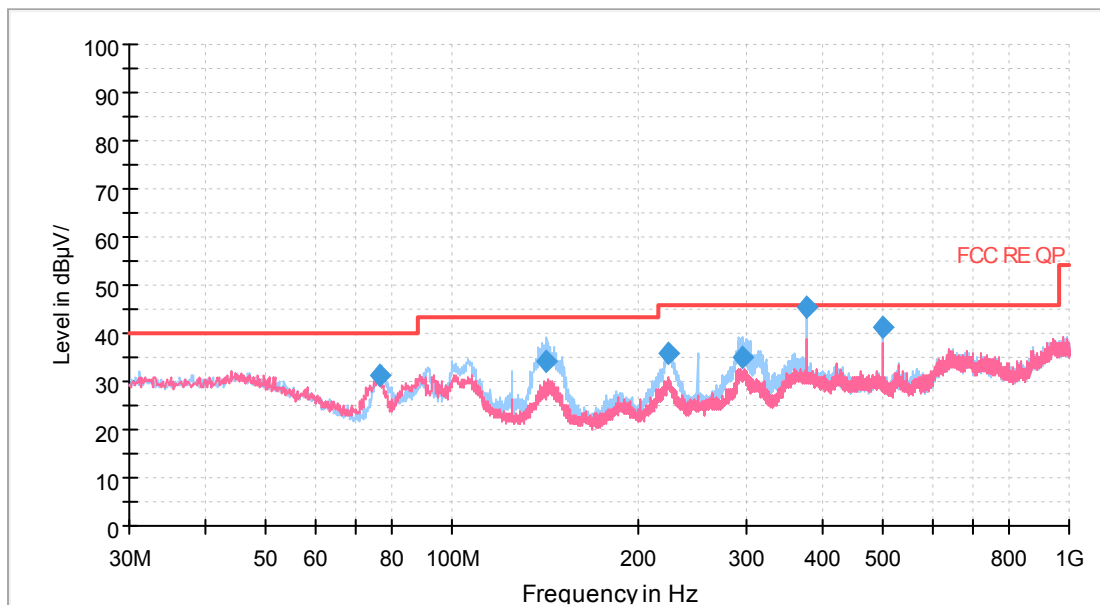
Continuous TX mode:

Radiates Emission from 30MHz to 1GHz

Frequency (MHz)	Quasi-Peak (dBuV/m)	Height (cm)	Polarization	Azimuth (deg)	Correct Factor (dB)	Margin (dB)	Limit (dBuV/m)
76.448600	31.09	225.0	H	0.0	-6.5	8.91	40.00
142.603700	34.19	225.0	H	232.0	-7.3	9.31	43.50
224.160750	35.72	125.0	H	29.0	-4.9	10.28	46.00
295.564500	35.04	109.0	H	262.0	-2.5	10.96	46.00
375.018750	45.29	100.0	H	334.0	1.5	0.71	46.00
499.996250	41.28	184.0	H	36.0	-0.1	4.72	46.00

Remark: 1. Correction Factor = Antenna factor+ Insertion loss(cable loss+amplifier gain)

2. Margin = Limit – Quasi-Peak



802.11a CH36

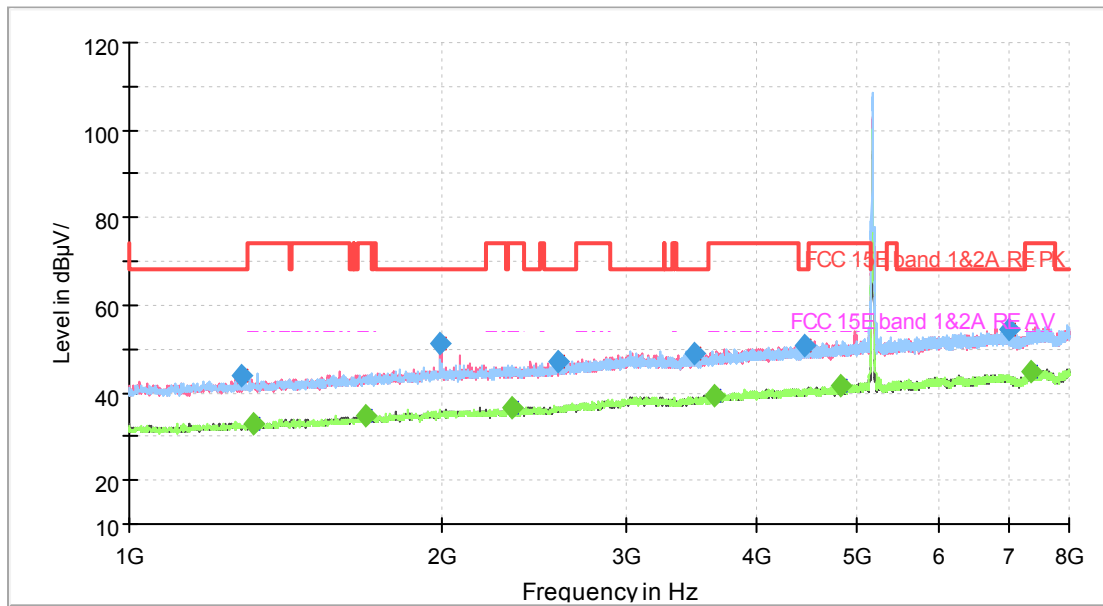

Note: The signal beyond the limit is carrier.
Radiates Emission from 1GHz to 8GHz

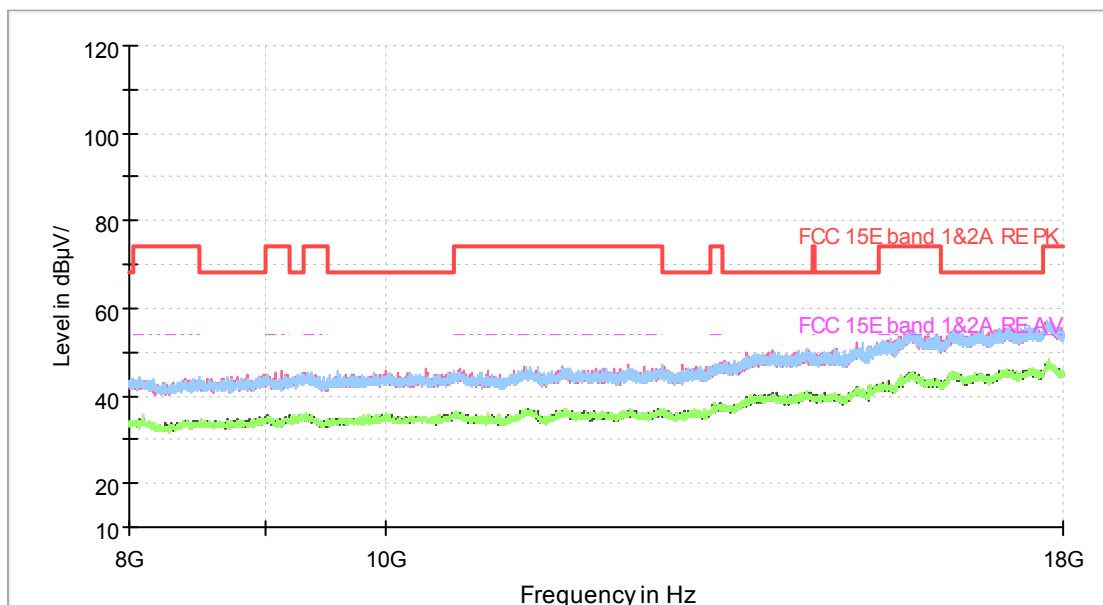

Radiates Emission from 8GHz to 18GHz



Frequency (MHz)	MaxPeak (dB μ V/m)	Average (dB μ V/m)	Limit (dB μ V/m)	Margin (dB)	Height (cm)	Pol	Azimuth (deg)	Corr. (dB/m)
1280.875000	43.82	---	68.20	24.38	100.0	H	344.0	0.4
1315.000000	---	32.88	54.00	21.12	100.0	H	0.0	0.7
1689.500000	---	34.66	54.00	19.34	100.0	V	57.0	2.3
1991.375000	51.23	---	68.20	16.97	200.0	V	290.0	3.8
2327.375000	---	36.53	54.00	17.47	200.0	H	286.0	5.0
2583.750000	47.35	---	68.20	20.85	200.0	H	0.0	5.9
3487.625000	49.04	---	68.20	19.16	100.0	V	218.0	9.0
3646.875000	---	39.41	54.00	14.59	200.0	V	146.0	9.6
4447.500000	50.62	---	68.20	17.58	200.0	V	85.0	11.5
4825.500000	---	41.82	54.00	12.18	200.0	V	85.0	12.6
6997.250000	54.56	---	68.20	13.64	200.0	H	311.0	16.3
7356.875000	---	44.85	54.00	9.15	100.0	H	117.0	17.2

Remark: 1. Correction Factor = Antenna factor+ Insertion loss (cable loss + amplifier gain)



802.11a CH40

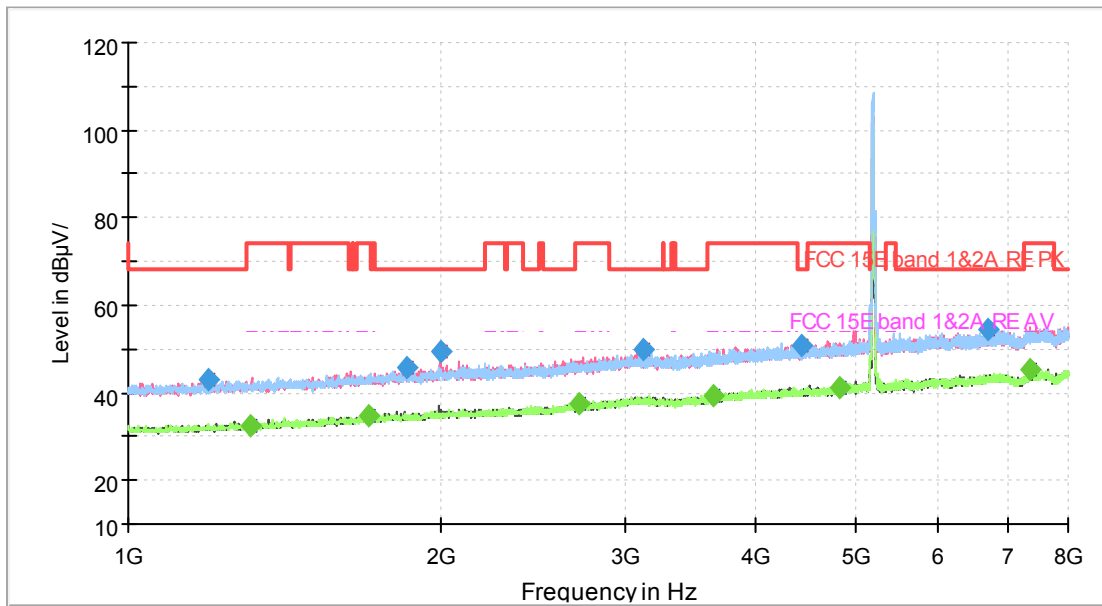

Note: The signal beyond the limit is carrier.
Radiates Emission from 1GHz to 8GHz

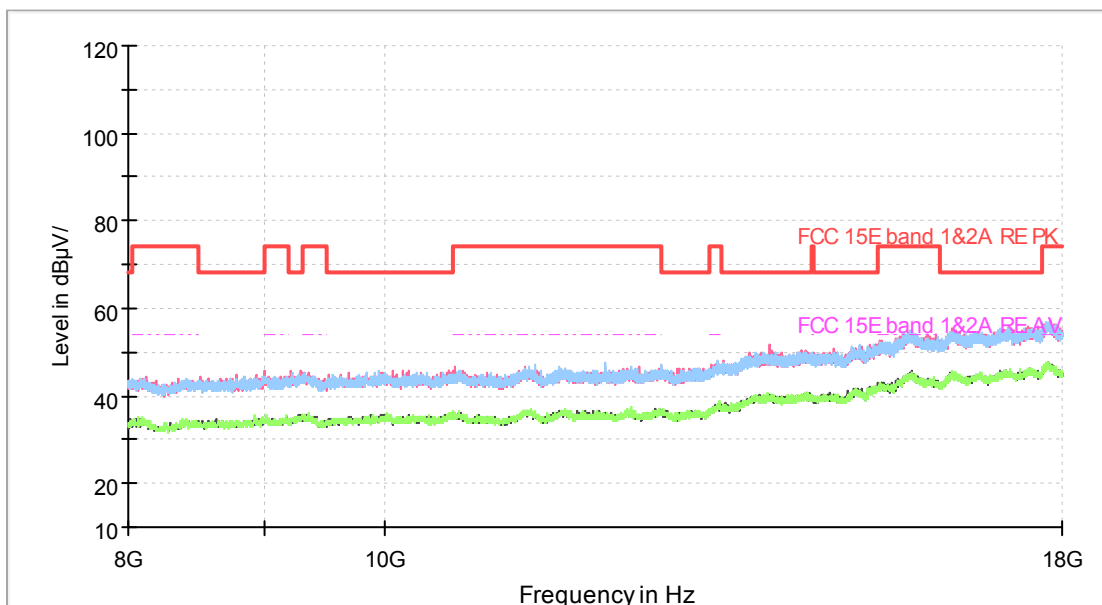

Radiates Emission from 8GHz to 18GHz



Frequency (MHz)	MaxPeak (dB μ V/m)	Average (dB μ V/m)	Limit (dB μ V/m)	Margin (dB)	Meas. Time (ms)	Height (cm)	Pol	Azimuth (deg)	Corr. (dB/m)
1196.000000	42.81	---	68.20	25.39	200.0	200.0	V	97.0	0.1
1310.625000	---	32.49	54.00	21.51	200.0	200.0	V	182.0	0.6
1706.125000	---	34.88	54.00	19.12	200.0	100.0	V	344.0	2.6
1848.750000	45.94	---	68.20	22.26	200.0	200.0	V	29.0	3.1
1994.000000	49.38	---	68.20	18.82	200.0	100.0	V	275.0	3.8
2709.750000	---	37.48	54.00	16.52	200.0	100.0	H	54.0	6.6
3127.125000	50.07	---	68.20	18.13	200.0	100.0	V	217.0	8.2
3650.375000	---	39.34	54.00	14.66	200.0	100.0	H	86.0	9.6
4443.125000	50.75	---	68.20	17.45	200.0	100.0	H	237.0	11.5
4818.500000	---	41.38	54.00	12.62	200.0	200.0	H	332.0	12.6
6704.125000	54.56	---	68.20	13.64	200.0	100.0	V	208.0	16.0
7360.375000	---	45.07	54.00	8.94	200.0	100.0	H	297.0	17.2

Remark: 1. Correction Factor = Antenna factor+ Insertion loss (cable loss + amplifier gain)



802.11a CH48

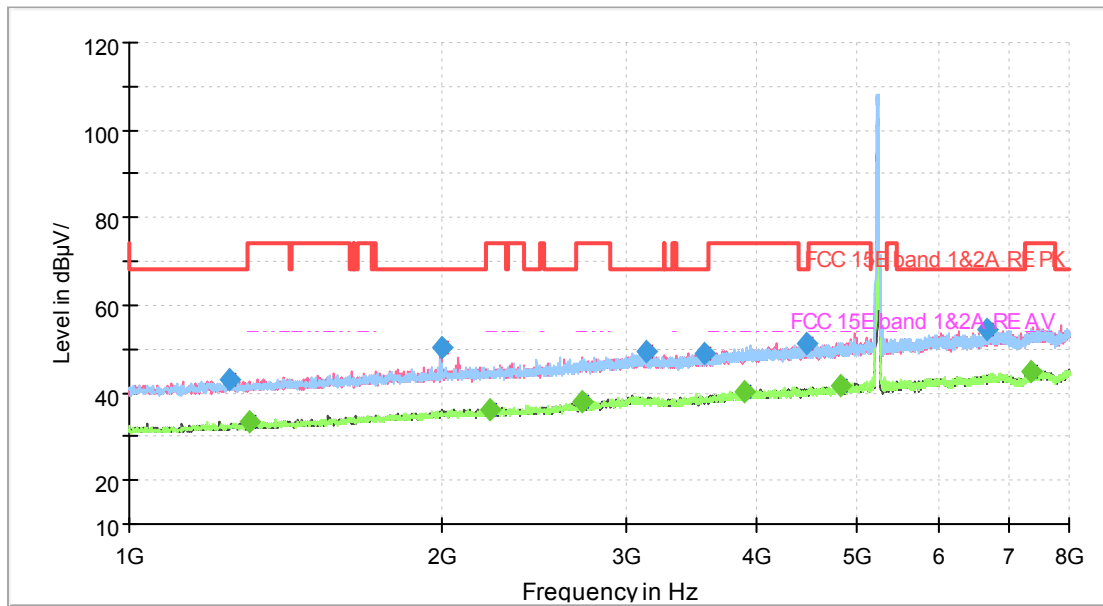

Note: The signal beyond the limit is carrier.
Radiates Emission from 1GHz to 8GHz

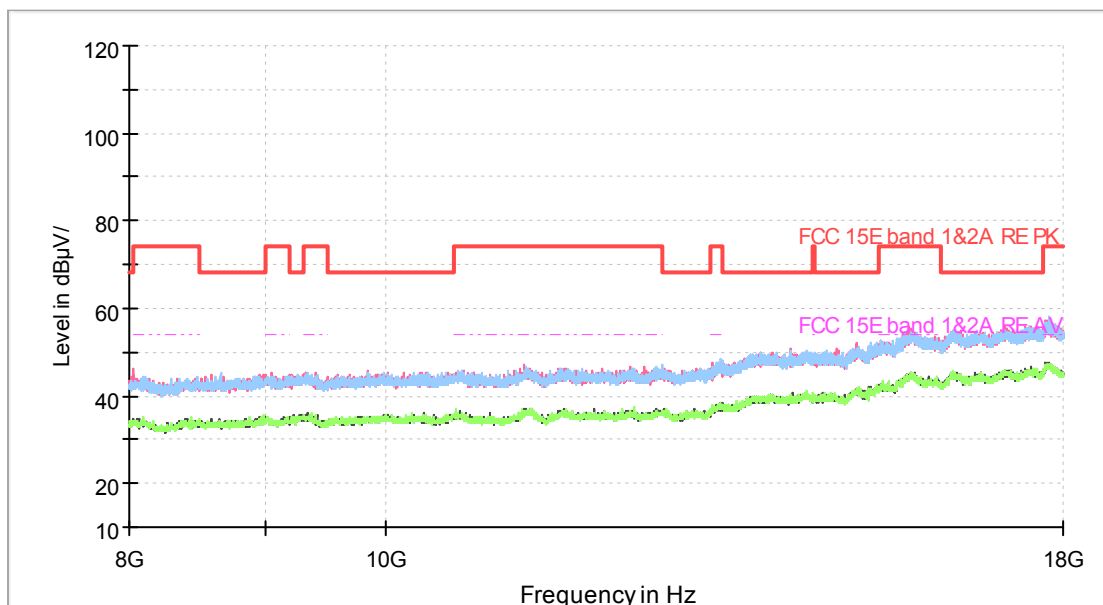

Radiates Emission from 8GHz to 18GHz



Frequency (MHz)	MaxPeak (dB μ V/m)	Average (dB μ V/m)	Limit (dB μ V/m)	Margin (dB)	Meas. Time (ms)	Height (cm)	Pol	Azimuth (deg)	Corr. (dB/m)
1246.750000	42.97	---	68.20	25.23	200.0	100.0	H	342.0	0.2
1305.375000	---	33.26	54.00	20.74	200.0	200.0	H	166.0	0.5
1995.750000	50.15	---	68.20	18.05	200.0	200.0	V	56.0	3.9
2219.750000	---	36.03	54.00	17.97	200.0	100.0	V	119.0	4.4
2722.000000	---	37.77	54.00	16.23	200.0	100.0	V	0.0	6.8
3140.250000	49.32	---	68.20	18.88	200.0	100.0	V	56.0	8.2
3569.875000	49.05	---	68.20	19.15	200.0	200.0	H	222.0	9.2
3897.125000	---	40.24	54.00	13.76	200.0	200.0	V	271.0	10.5
4470.250000	51.14	---	68.20	17.06	200.0	200.0	V	345.0	11.6
4829.000000	---	41.43	54.00	12.57	200.0	100.0	V	273.0	12.6
6684.000000	54.37	---	68.20	13.83	200.0	200.0	V	131.0	15.9
7357.750000	---	44.96	54.00	9.04	200.0	100.0	V	273.0	17.2

Remark: 1. Correction Factor = Antenna factor+ Insertion loss (cable loss + amplifier gain)



802.11a CH149

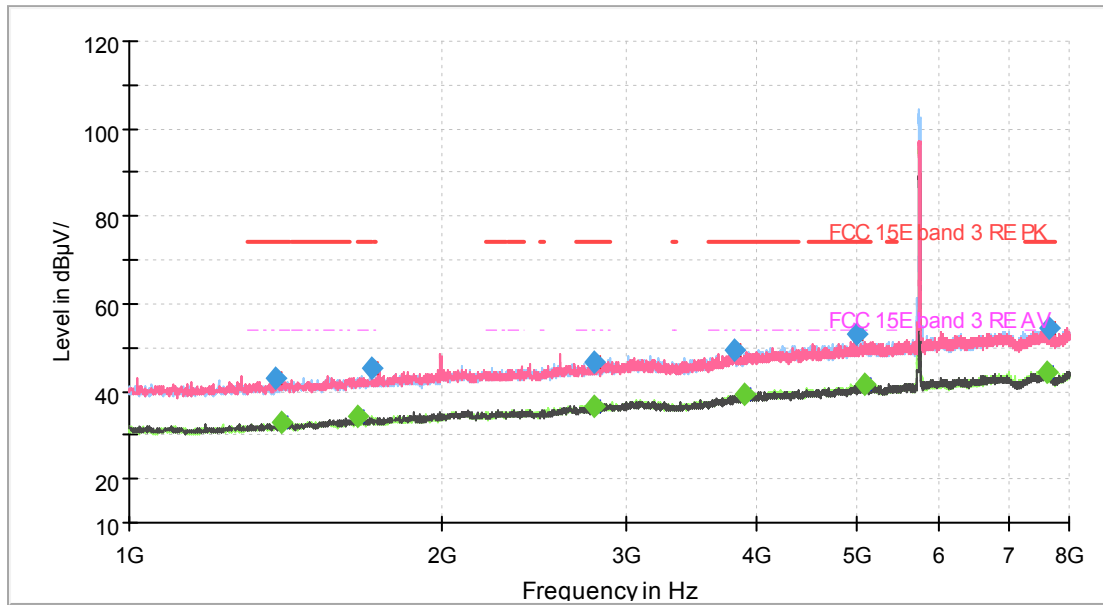

Note: The signal beyond the limit is carrier.
Radiates Emission from 1GHz to 8GHz

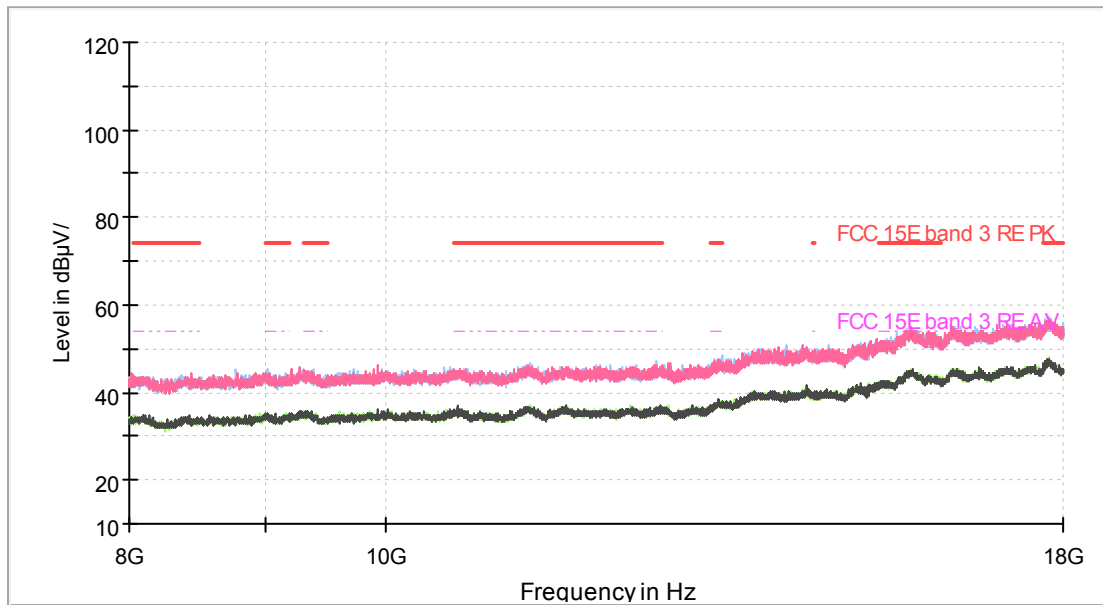

Radiates Emission from 8GHz to 18GHz



Frequency (MHz)	MaxPeak (dB μ V/m)	Average (dB μ V/m)	Limit (dB μ V/m)	Margin (dB)	Height (cm)	Pol	Azimuth (deg)	Corr. (dB/m)
1379.750000	42.90	---	74.00	31.10	200.0	H	158.0	0.8
1401.625000	---	32.79	54.00	21.21	200.0	H	327.0	1.0
1660.625000	---	34.26	54.00	19.74	100.0	V	138.0	2.2
1709.625000	45.14	---	74.00	28.86	100.0	V	180.0	2.5
2795.500000	46.66	---	74.00	27.34	200.0	H	276.0	7.0
2799.000000	---	36.74	54.00	17.26	200.0	H	53.0	7.0
3821.000000	49.21	---	74.00	24.79	200.0	V	338.0	10.3
3905.875000	---	39.54	54.00	14.46	100.0	H	218.0	10.5
4992.625000	52.95	---	74.00	21.05	100.0	V	296.0	12.8
5084.500000	---	41.67	54.00	12.33	100.0	V	95.0	13.5
7631.625000	---	44.51	54.00	9.49	200.0	V	313.0	17.7
7666.625000	54.36	---	74.00	19.64	200.0	H	0.0	17.7

Remark: 1. Correction Factor = Antenna factor+ Insertion loss (cable loss + amplifier gain)



802.11a CH157

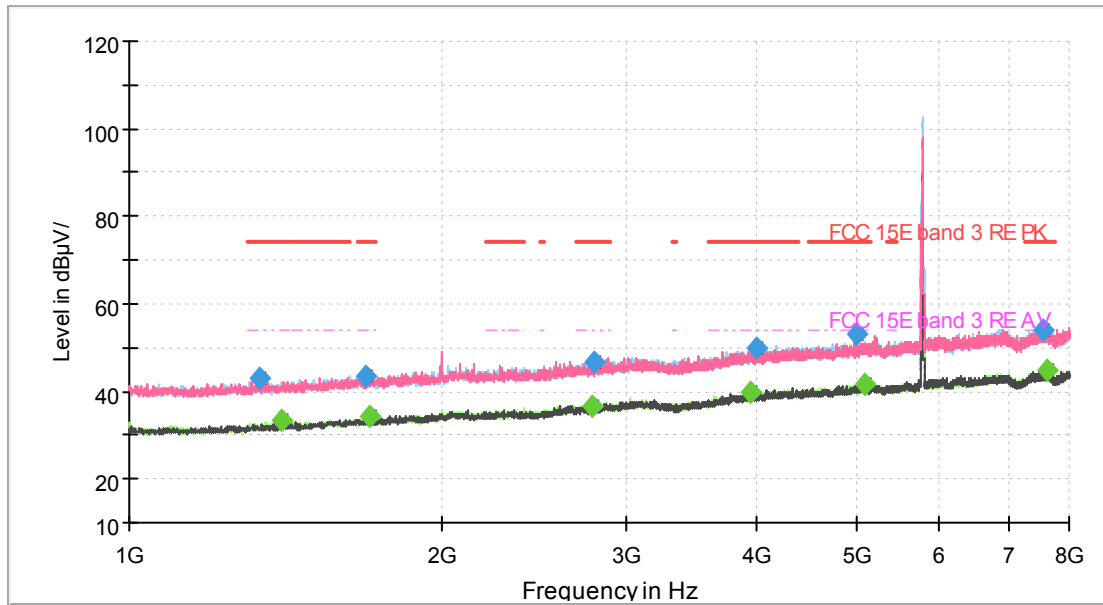

Note: The signal beyond the limit is carrier.
Radiates Emission from 1GHz to 8GHz

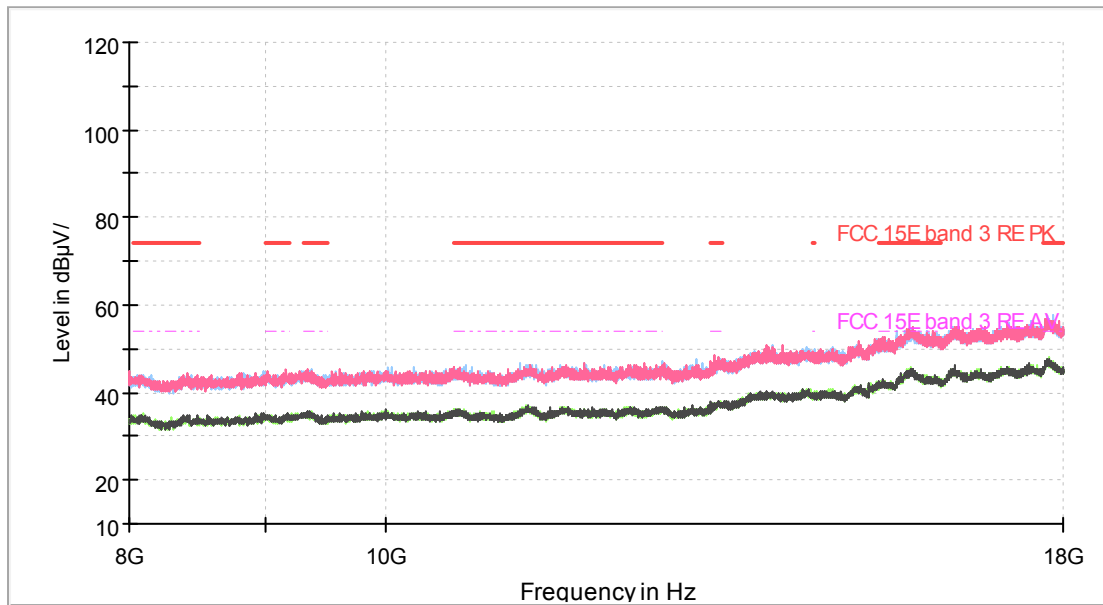

Radiates Emission from 8GHz to 18GHz



Frequency (MHz)	MaxPeak (dB μ V/m)	Average (dB μ V/m)	Limit (dB μ V/m)	Margin (dB)	Meas. Time (ms)	Height (cm)	Pol	Azimuth (deg)	Corr. (dB/m)
1332.500000	42.77	---	74.00	31.23	200.0	100.0	V	0.0	0.7
1402.500000	---	33.21	54.00	20.79	200.0	200.0	H	358.0	1.0
1690.375000	43.44	---	74.00	30.56	200.0	200.0	H	6.0	2.3
1703.500000	---	34.25	54.00	19.75	200.0	200.0	V	17.0	2.5
2779.750000	---	36.80	54.00	17.20	200.0	100.0	H	31.0	6.8
2798.125000	46.81	---	74.00	27.19	200.0	100.0	H	28.0	7.0
3954.000000	---	39.62	54.00	14.38	200.0	100.0	V	274.0	10.6
3997.750000	49.83	---	74.00	24.17	200.0	200.0	H	87.0	10.7
4997.875000	53.22	---	74.00	20.78	200.0	100.0	V	312.0	12.9
5082.750000	---	41.66	54.00	12.34	200.0	100.0	V	244.0	13.5
7553.750000	54.12	---	74.00	19.88	200.0	100.0	V	312.0	17.4
7615.000000	---	44.72	54.00	9.28	200.0	100.0	V	4.0	17.6

Remark: 1. Correction Factor = Antenna factor+ Insertion loss (cable loss + amplifier gain)



802.11a CH165

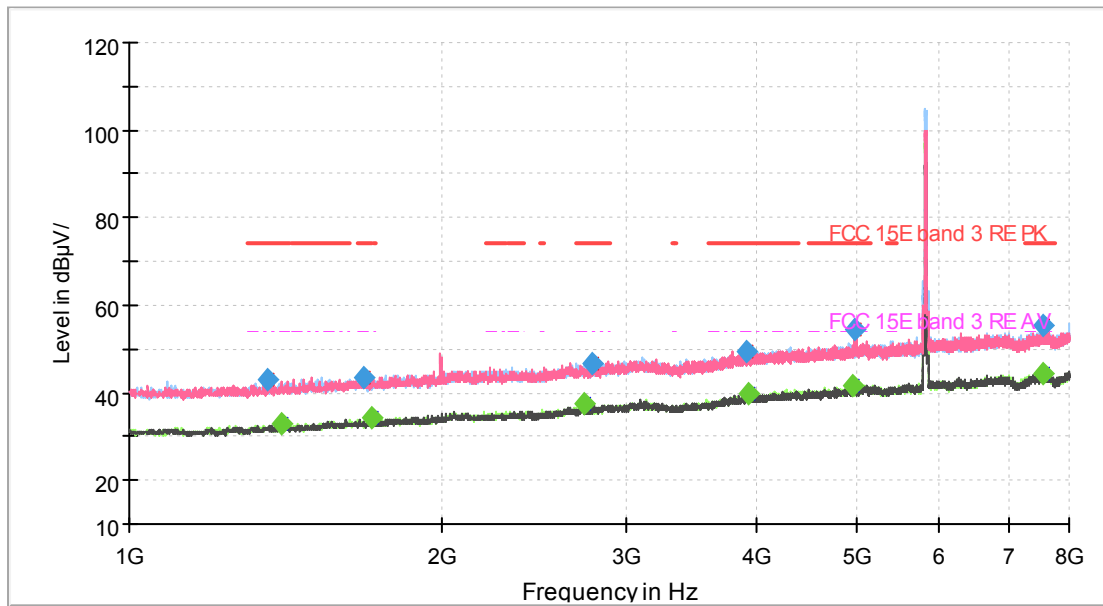

Note: The signal beyond the limit is carrier.
Radiates Emission from 1GHz to 8GHz

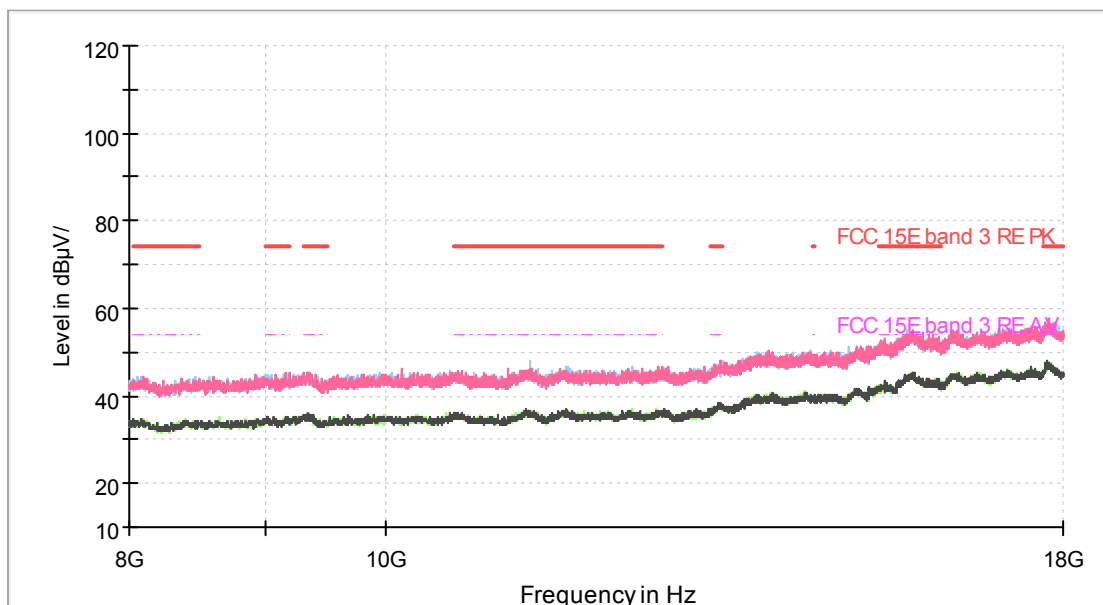

Radiates Emission from 8GHz to 18GHz



Frequency (MHz)	MaxPeak (dB μ V/m)	Average (dB μ V/m)	Limit (dB μ V/m)	Margin (dB)	Height (cm)	Pol	Azimuth (deg)	Corr. (dB/m)
1358.750000	43.06	---	74.00	30.94	100.0	H	210.0	0.8
1403.375000	---	33.04	54.00	20.96	200.0	V	59.0	1.0
1682.500000	43.46	---	74.00	30.54	100.0	H	336.0	2.2
1707.000000	---	34.15	54.00	19.85	100.0	H	347.0	2.5
2737.750000	---	37.29	54.00	16.71	100.0	V	35.0	6.8
2783.250000	46.82	---	74.00	27.18	100.0	V	1.0	6.8
3926.000000	49.25	---	74.00	24.75	100.0	V	207.0	10.6
3943.500000	---	39.63	54.00	14.37	200.0	H	182.0	10.6
4966.375000	---	41.58	54.00	12.42	100.0	H	329.0	12.9
4985.625000	54.41	---	74.00	19.59	100.0	V	316.0	12.9
7545.875000	---	44.36	54.00	9.64	100.0	H	241.0	17.4
7556.375000	55.37	---	74.00	18.63	200.0	V	317.0	17.4

Remark: 1. Correction Factor = Antenna factor+ Insertion loss (cable loss + amplifier gain)



802.11n (HT20) CH36

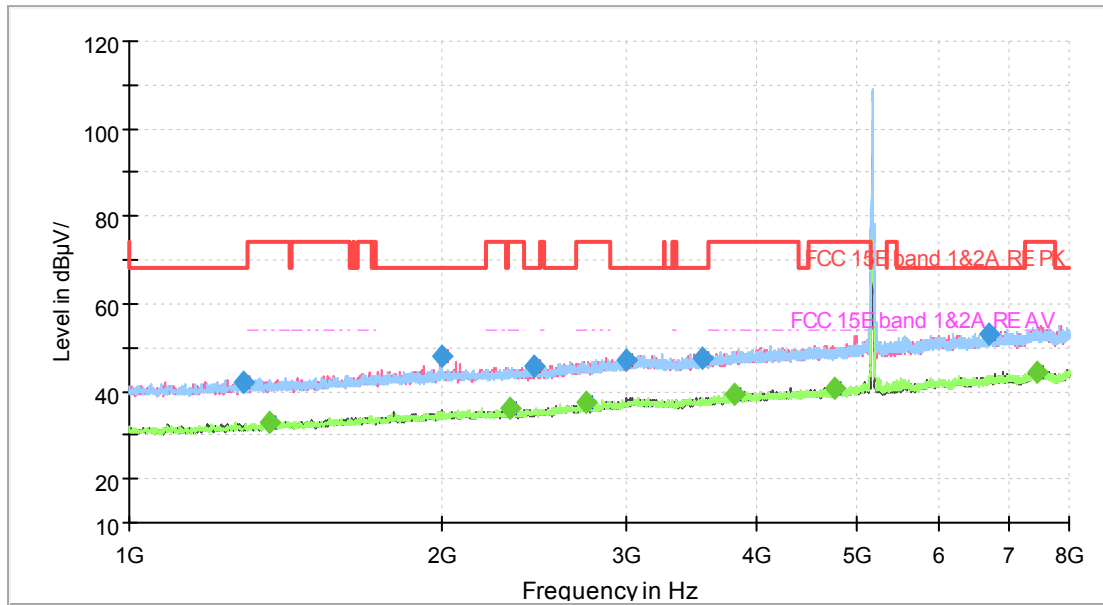

Note: The signal beyond the limit is carrier.
Radiates Emission from 1GHz to 8GHz

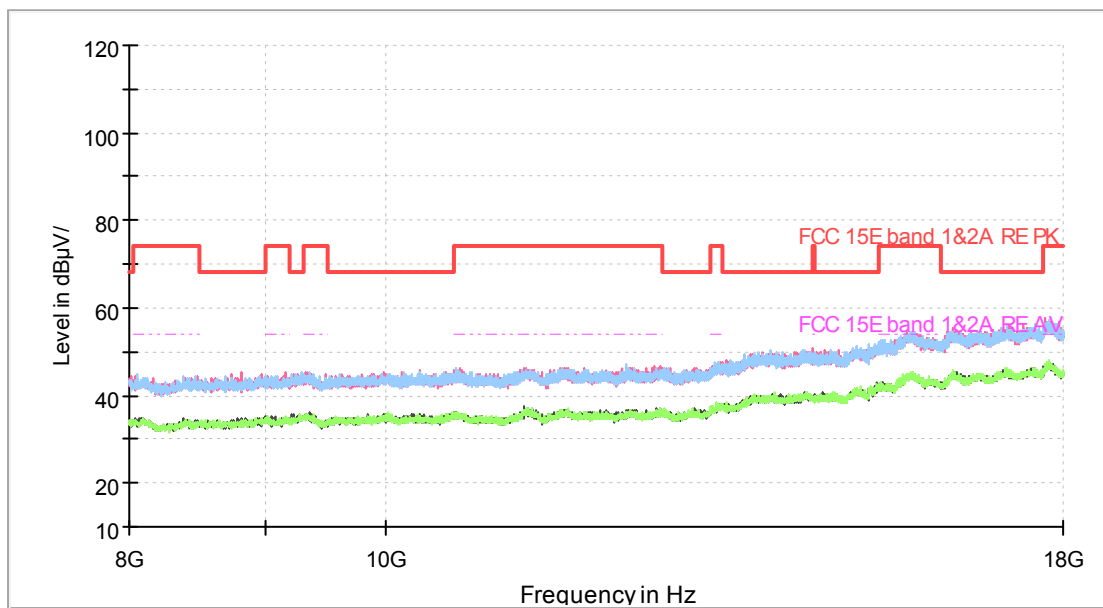

Radiates Emission from 8GHz to 18GHz



Frequency (MHz)	MaxPeak (dB μ V/m)	Average (dB μ V/m)	Limit (dB μ V/m)	Margin (dB)	Meas. Time (ms)	Height (cm)	Pol	Azimuth (deg)	Corr. (dB/m)
1286.125000	42.22	---	68.20	25.98	200.0	200.0	V	96.0	0.4
1362.250000	---	32.78	54.00	21.22	200.0	200.0	V	14.0	0.8
1995.750000	48.16	---	68.20	20.04	200.0	100.0	V	118.0	3.9
2326.500000	---	35.90	54.00	18.10	200.0	100.0	V	153.0	5.0
2452.500000	45.68	---	68.20	22.52	200.0	200.0	V	238.0	5.5
2743.000000	---	37.46	54.00	16.54	200.0	200.0	V	327.0	6.7
3002.875000	46.95	---	68.20	21.25	200.0	200.0	V	324.0	8.1
3553.250000	47.60	---	68.20	20.60	200.0	100.0	V	21.0	9.1
3821.875000	---	39.48	54.00	14.52	200.0	100.0	V	78.0	10.3
4772.125000	---	40.70	54.00	13.30	200.0	100.0	V	347.0	12.4
6698.875000	53.22	---	68.20	14.98	200.0	100.0	V	122.0	16.0
7461.000000	---	44.56	54.00	9.44	200.0	200.0	V	132.0	17.2

Remark: 1. Correction Factor = Antenna factor+ Insertion loss (cable loss + amplifier gain)



802.11n (HT20) CH40

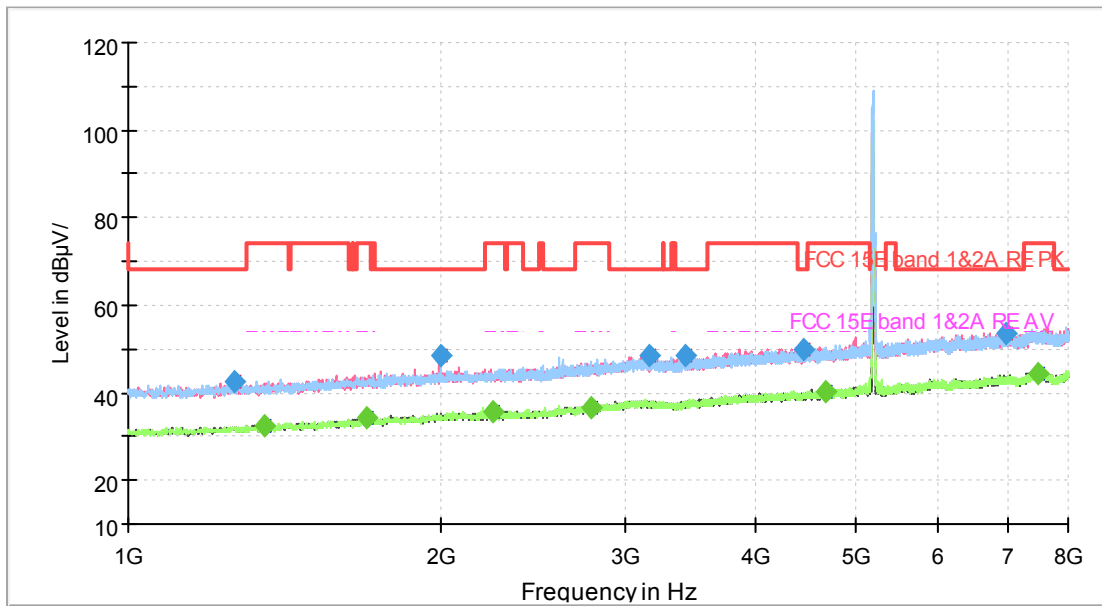

Note: The signal beyond the limit is carrier.
Radiates Emission from 1GHz to 8GHz

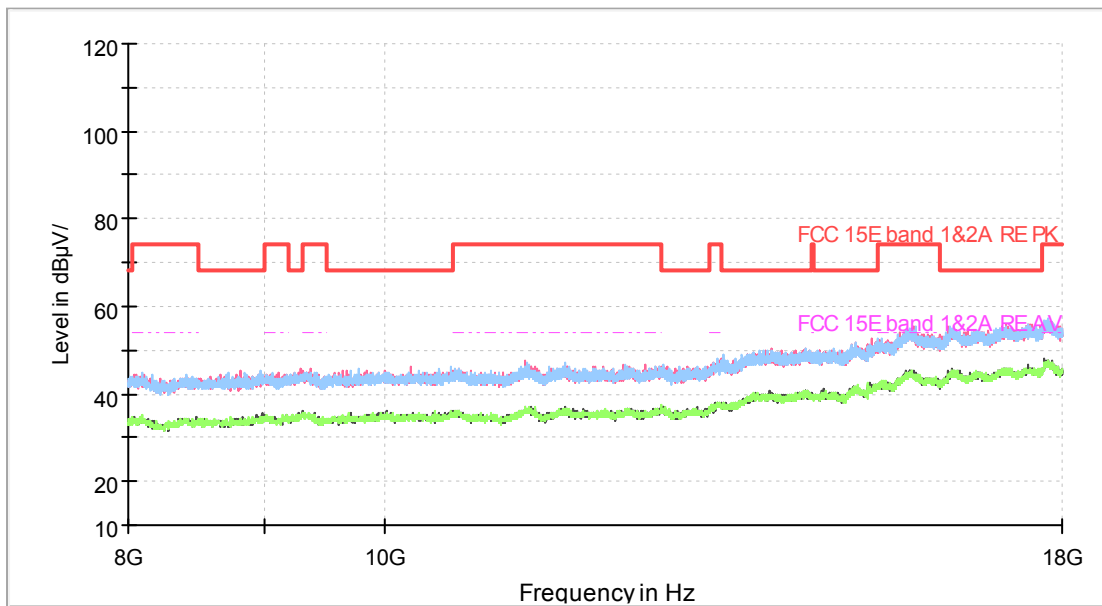

Radiates Emission from 8GHz to 18GHz



Frequency (MHz)	MaxPeak (dB μ V/m)	Average (dB μ V/m)	Limit (dB μ V/m)	Margin (dB)	Meas. Time (ms)	Height (cm)	Pol	Azimuth (deg)	Corr. (dB/m)
1266.000000	42.38	---	68.20	25.82	200.0	200.0	V	139.0	0.3
1350.000000	---	32.28	54.00	21.72	200.0	100.0	V	116.0	0.8
1692.125000	---	34.11	54.00	19.89	200.0	200.0	H	277.0	2.3
1996.625000	48.67	---	68.20	19.53	200.0	100.0	V	0.0	3.9
2239.000000	---	35.48	54.00	18.52	200.0	200.0	V	337.0	4.5
2785.000000	---	36.78	54.00	17.22	200.0	200.0	V	75.0	6.8
3163.000000	48.55	---	68.20	19.65	200.0	100.0	H	0.0	8.3
3426.375000	48.53	---	68.20	19.67	200.0	100.0	V	317.0	8.6
4446.625000	49.76	---	68.20	18.44	200.0	200.0	V	242.0	11.5
4675.000000	---	40.42	54.00	13.58	200.0	200.0	V	39.0	12.3
6982.375000	53.46	---	68.20	14.74	200.0	100.0	V	217.0	16.3
7475.875000	---	44.42	54.00	9.58	200.0	200.0	V	51.0	17.3

Remark: 1. Correction Factor = Antenna factor+ Insertion loss (cable loss + amplifier gain)



802.11n (HT20) CH48

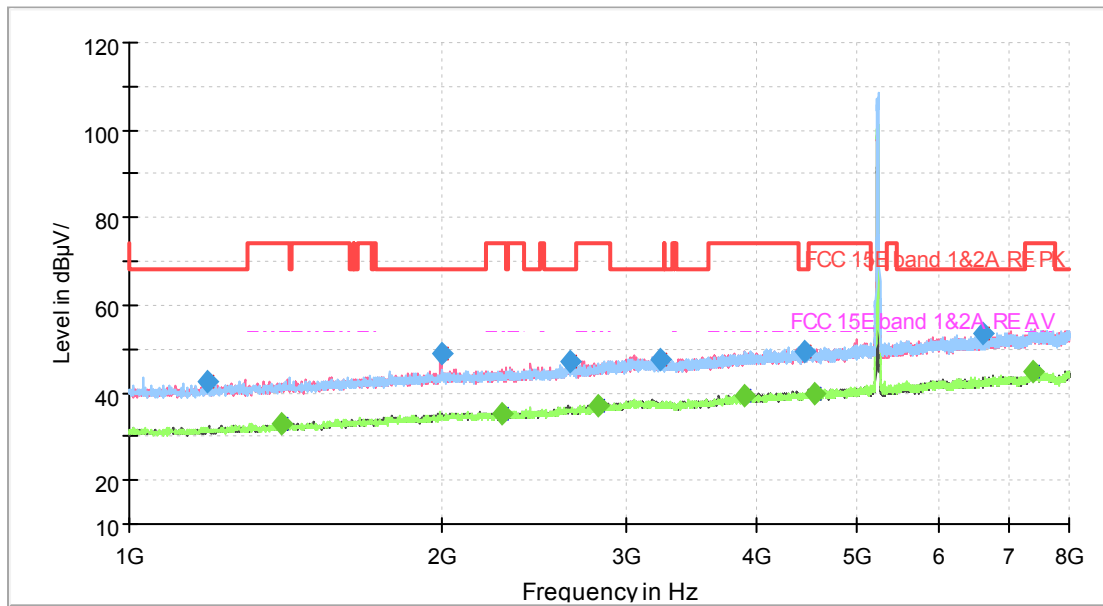

Note: The signal beyond the limit is carrier.
Radiates Emission from 1GHz to 8GHz

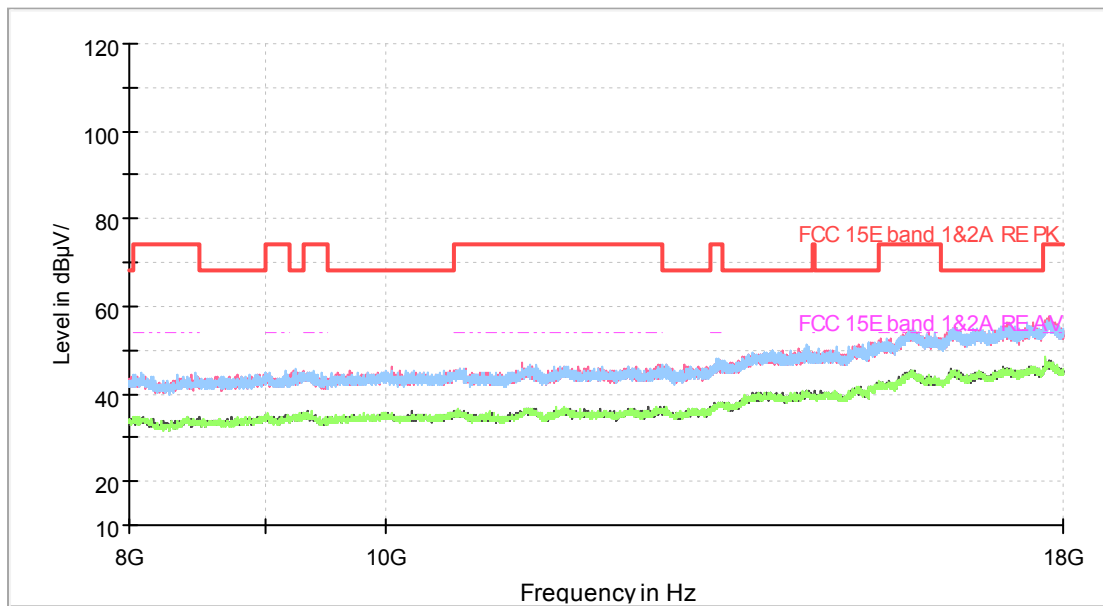

Radiates Emission from 8GHz to 18GHz



Frequency (MHz)	MaxPeak (dB μ V/m)	Average (dB μ V/m)	Limit (dB μ V/m)	Margin (dB)	Meas. Time (ms)	Height (cm)	Pol	Azimuth (deg)	Corr. (dB/m)
1189.000000	42.77	---	68.20	25.43	200.0	200.0	V	19.0	0.1
1403.375000	---	33.04	54.00	20.96	200.0	200.0	V	51.0	1.0
1998.375000	48.81	---	68.20	19.39	200.0	100.0	V	326.0	3.9
2280.125000	---	35.29	54.00	18.71	200.0	100.0	H	92.0	4.8
2646.750000	47.04	---	68.20	21.16	200.0	100.0	V	338.0	6.3
2827.875000	---	36.95	54.00	17.05	200.0	100.0	V	313.0	7.0
3235.625000	47.81	---	68.20	20.39	200.0	100.0	H	3.0	8.3
3904.125000	---	39.17	54.00	14.83	200.0	200.0	V	321.0	10.5
4462.375000	49.57	---	68.20	18.63	200.0	200.0	V	75.0	11.6
4562.125000	---	39.84	54.00	14.16	200.0	200.0	H	309.0	12.0
6606.125000	53.63	---	68.20	14.57	200.0	200.0	V	83.0	15.7
7392.750000	---	44.76	54.00	9.24	200.0	200.0	V	225.0	17.2

Remark: 1. Correction Factor = Antenna factor+ Insertion loss (cable loss + amplifier gain)



802.11n (HT20) CH149

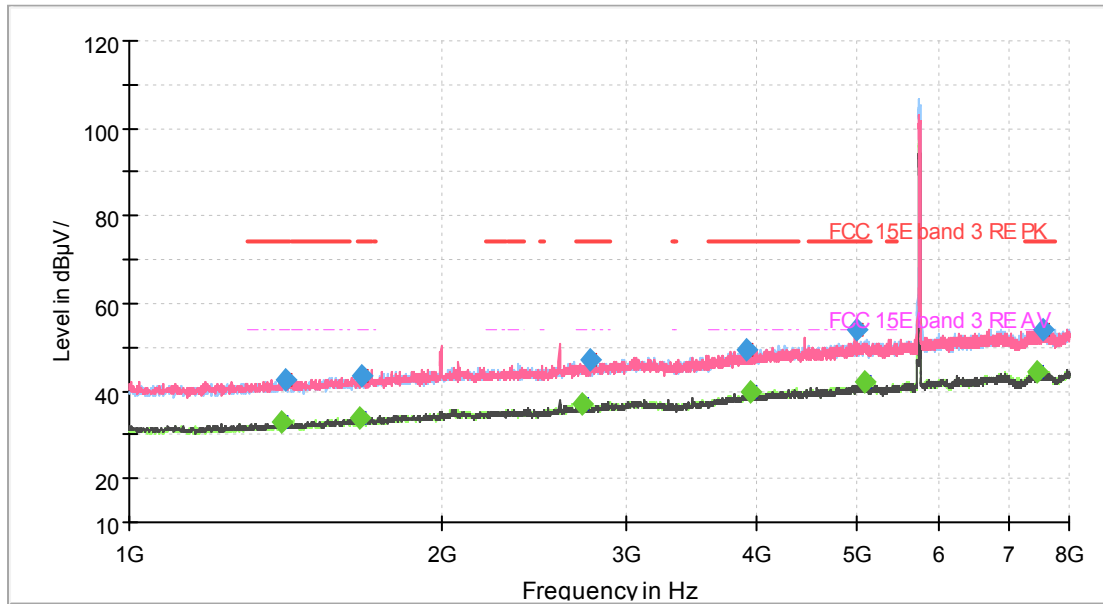

Note: The signal beyond the limit is carrier.
Radiates Emission from 1GHz to 8GHz

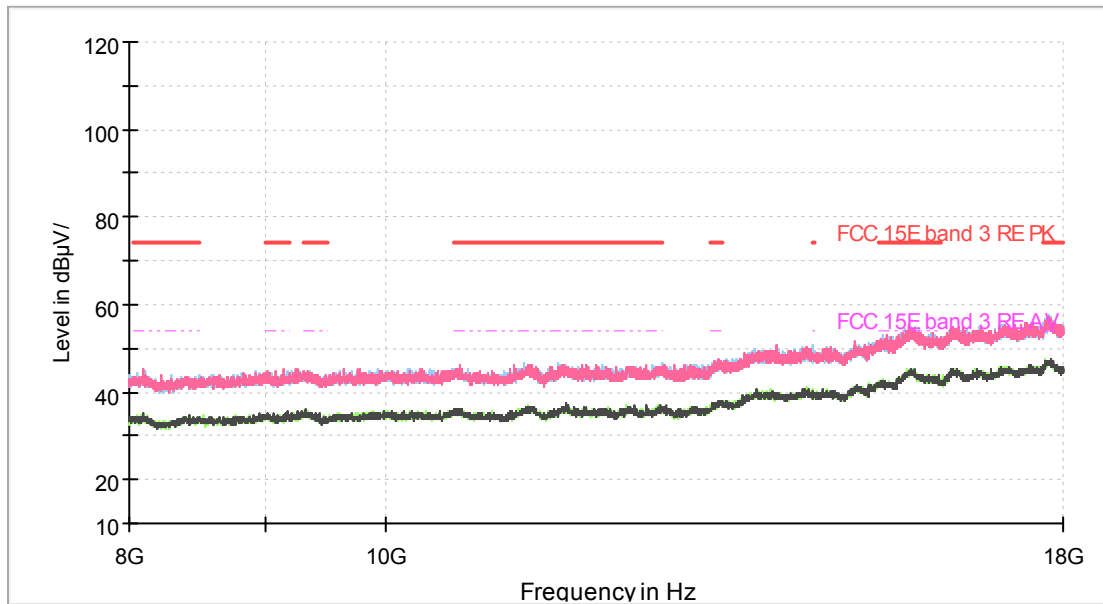

Radiates Emission from 8GHz to 18GHz



Frequency (MHz)	MaxPeak (dB μ V/m)	Average (dB μ V/m)	Limit (dB μ V/m)	Margin (dB)	Meas. Time (ms)	Height (cm)	Pol	Azimuth (deg)	Corr. (dB/m)
1402.500000	---	32.87	54.00	21.13	200.0	200.0	V	317.0	1.0
1413.000000	42.60	---	74.00	31.40	200.0	200.0	V	40.0	1.1
1665.875000	---	33.88	54.00	20.12	200.0	200.0	H	173.0	2.2
1672.000000	43.66	---	74.00	30.34	200.0	200.0	H	54.0	2.3
2725.500000	---	37.11	54.00	16.90	200.0	100.0	V	122.0	6.8
2775.375000	47.11	---	74.00	26.89	200.0	200.0	V	354.0	6.7
3915.500000	49.57	---	74.00	24.43	200.0	200.0	H	167.0	10.6
3948.750000	---	39.65	54.00	14.35	200.0	100.0	H	330.0	10.6
4991.750000	54.01	---	74.00	19.99	200.0	100.0	V	313.0	12.8
5078.375000	---	41.92	54.00	12.08	200.0	100.0	H	0.0	13.5
7448.750000	---	44.39	54.00	9.61	200.0	100.0	V	148.0	17.2
7552.875000	53.78	---	74.00	20.22	200.0	200.0	H	104.0	17.4

Remark: 1. Correction Factor = Antenna factor+ Insertion loss (cable loss + amplifier gain)



802.11n (HT20) CH157

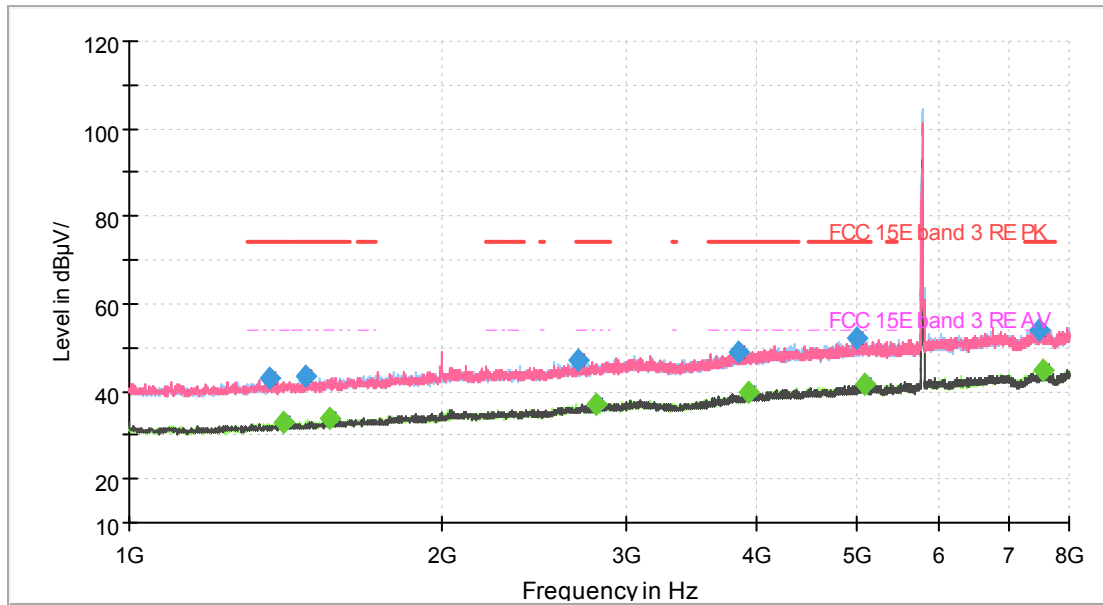

Note: The signal beyond the limit is carrier.
Radiates Emission from 1GHz to 8GHz

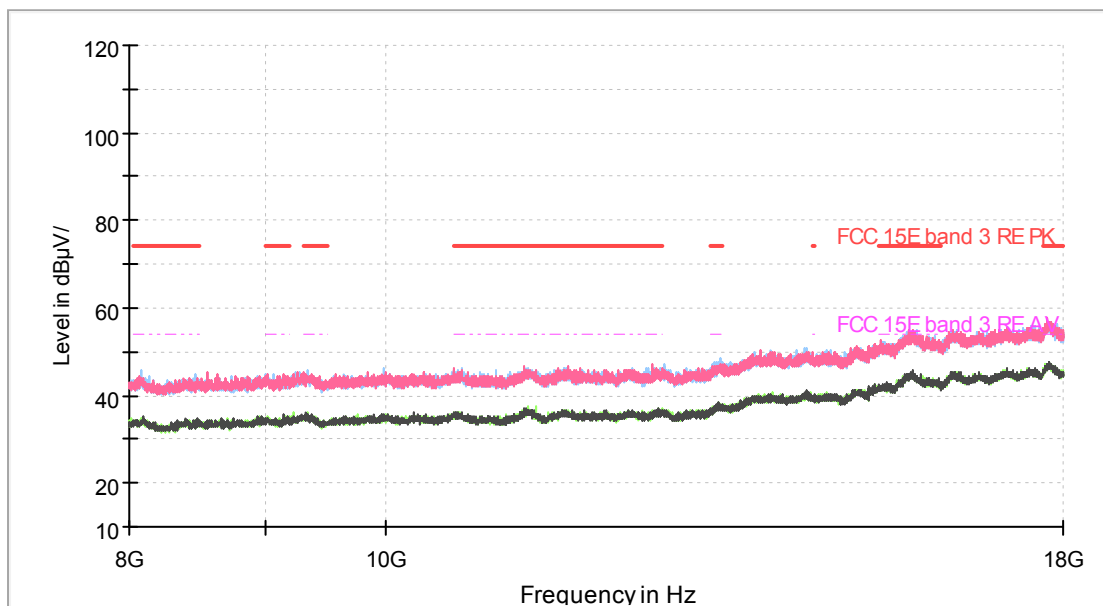

Radiates Emission from 8GHz to 18GHz



Frequency (MHz)	MaxPeak (dB μ V/m)	Average (dB μ V/m)	Limit (dB μ V/m)	Margin (dB)	Meas. Time (ms)	Height (cm)	Pol	Azimuth (deg)	Corr. (dB/m)
1364.000000	43.21	---	74.00	30.79	200.0	200.0	V	56.0	0.8
1409.500000	---	32.93	54.00	21.07	200.0	100.0	H	0.0	1.1
1477.750000	43.63	---	74.00	30.37	200.0	100.0	V	34.0	1.3
1554.750000	---	33.72	54.00	20.28	200.0	100.0	H	12.0	1.8
2702.750000	46.93	---	74.00	27.07	200.0	100.0	H	257.0	6.5
2811.250000	---	37.08	54.00	16.92	200.0	200.0	V	238.0	7.0
3854.250000	49.05	---	74.00	24.95	200.0	100.0	H	114.0	10.3
3940.000000	---	39.69	54.00	14.31	200.0	200.0	H	19.0	10.6
4995.250000	52.15	---	74.00	21.85	200.0	200.0	V	275.0	12.8
5082.750000	---	41.66	54.00	12.34	200.0	200.0	H	357.0	13.5
7491.625000	54.02	---	74.00	19.98	200.0	100.0	V	150.0	17.3
7551.125000	---	44.83	54.00	9.17	200.0	200.0	V	0.0	17.4

Remark: 1. Correction Factor = Antenna factor+ Insertion loss (cable loss + amplifier gain)



802.11n (HT20) CH165

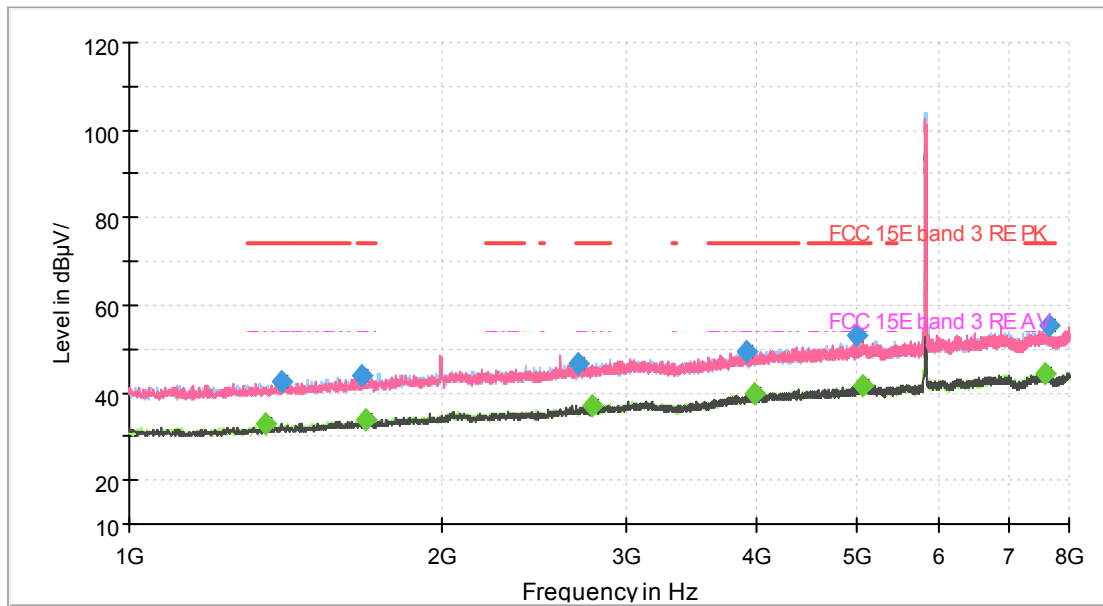

Note: The signal beyond the limit is carrier.
Radiates Emission from 1GHz to 8GHz

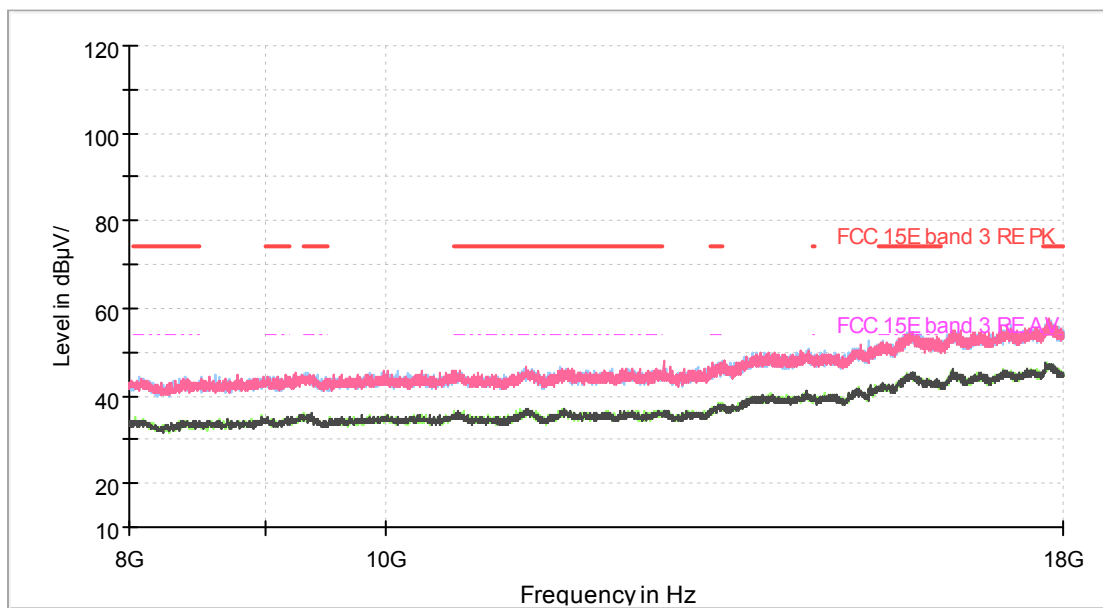

Radiates Emission from 8GHz to 18GHz



Frequency (MHz)	MaxPeak (dB μ V/m)	Average (dB μ V/m)	Limit (dB μ V/m)	Margin (dB)	Meas. Time (ms)	Height (cm)	Pol	Azimuth (deg)	Corr. (dB/m)
1352.625000	---	32.96	54.00	21.04	200.0	100.0	H	302.0	0.8
1399.875000	42.58	---	74.00	31.42	200.0	200.0	V	294.0	1.0
1672.000000	43.81	---	74.00	30.19	200.0	200.0	V	169.0	2.3
1687.750000	---	33.89	54.00	20.11	200.0	200.0	H	198.0	2.3
2697.500000	46.68	---	74.00	27.32	200.0	200.0	H	332.0	6.4
2785.000000	---	37.06	54.00	16.94	200.0	100.0	H	236.0	6.8
3921.625000	49.63	---	74.00	24.37	200.0	100.0	V	324.0	10.6
3983.750000	---	39.88	54.00	14.12	200.0	200.0	V	275.0	10.7
4998.750000	52.98	---	74.00	21.02	200.0	100.0	V	317.0	12.9
5076.625000	---	41.60	54.00	12.40	200.0	200.0	V	60.0	13.5
7569.500000	---	44.37	54.00	9.63	200.0	100.0	V	65.0	17.5
7646.500000	55.55	---	74.00	18.45	200.0	100.0	H	58.0	17.7

Remark: 1. Correction Factor = Antenna factor+ Insertion loss (cable loss + amplifier gain)

802.11n (HT40) CH38

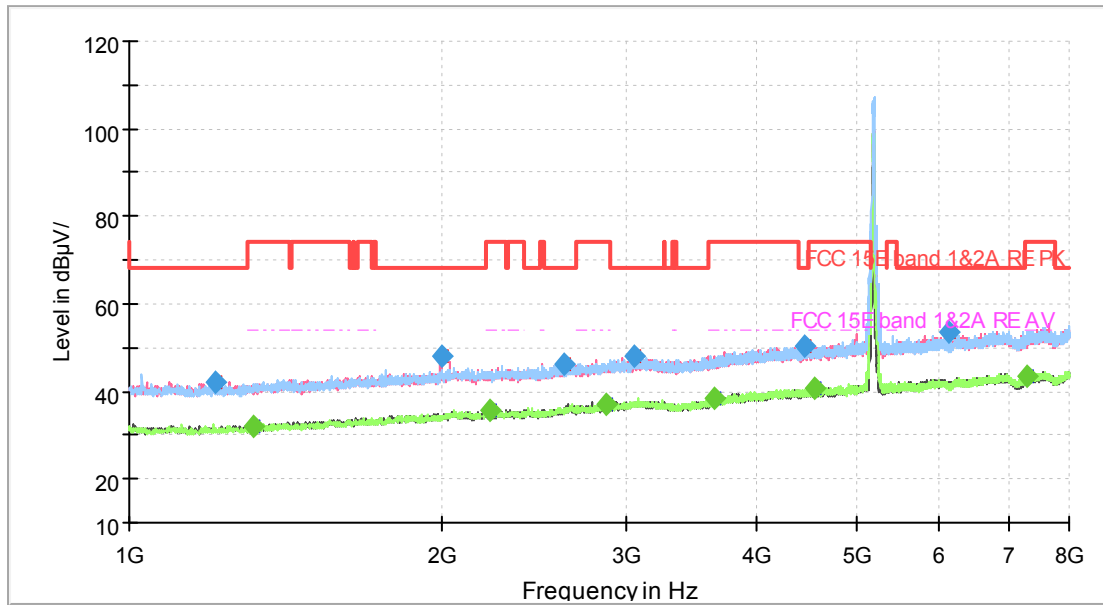

Note: The signal beyond the limit is carrier.
Radiates Emission from 1GHz to 8GHz

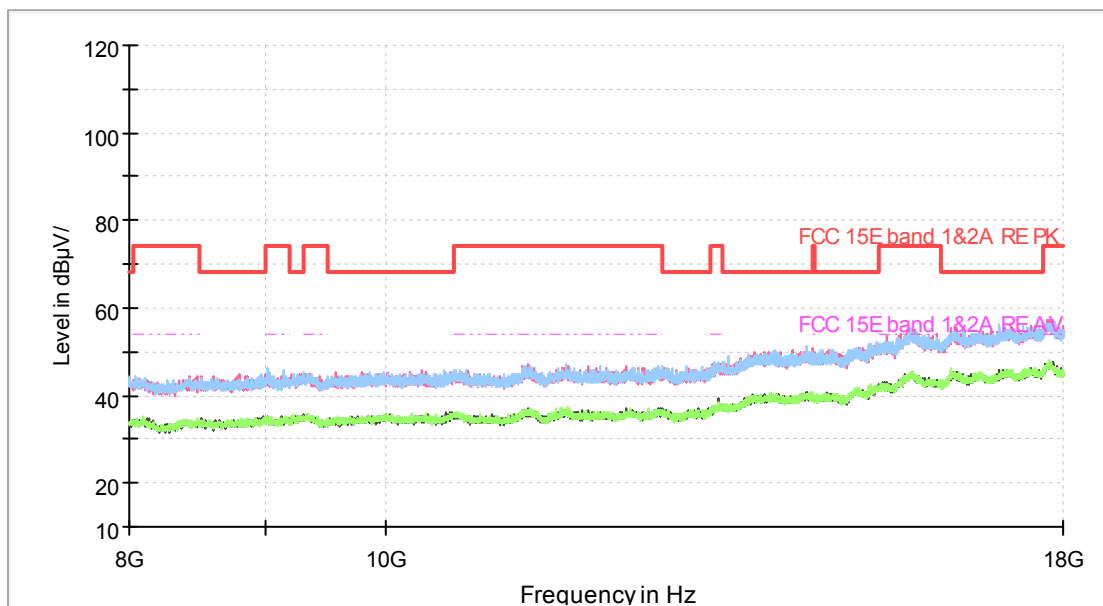

Radiates Emission from 8GHz to 18GHz



Frequency (MHz)	MaxPeak (dB μ V/m)	Average (dB μ V/m)	Limit (dB μ V/m)	Margin (dB)	Height (cm)	Pol	Azimuth (deg)	Corr. (dB/m)
1208.250000	41.96	---	68.20	26.24	100.0	V	330.0	0.0
1315.875000	---	32.09	54.00	21.91	100.0	V	235.0	0.7
1996.625000	47.95	---	68.20	20.25	100.0	V	210.0	3.9
2218.000000	---	35.81	54.00	18.19	100.0	H	169.0	4.4
2612.625000	46.43	---	68.20	21.77	200.0	V	0.0	5.9
2877.750000	---	37.26	54.00	16.74	200.0	V	252.0	7.5
3057.125000	47.90	---	68.20	20.30	100.0	H	343.0	8.4
3653.000000	---	38.48	54.00	15.52	200.0	H	196.0	9.6
4460.625000	50.15	---	68.20	18.05	100.0	V	214.0	11.6
4561.250000	---	40.52	54.00	13.48	200.0	V	67.0	11.9
6125.750000	53.67	---	68.20	14.53	100.0	V	342.0	14.6
7303.500000	---	43.68	54.00	10.32	100.0	H	153.0	17.0

Remark: 1. Correction Factor = Antenna factor+ Insertion loss (cable loss + amplifier gain)



802.11n (HT40) CH46

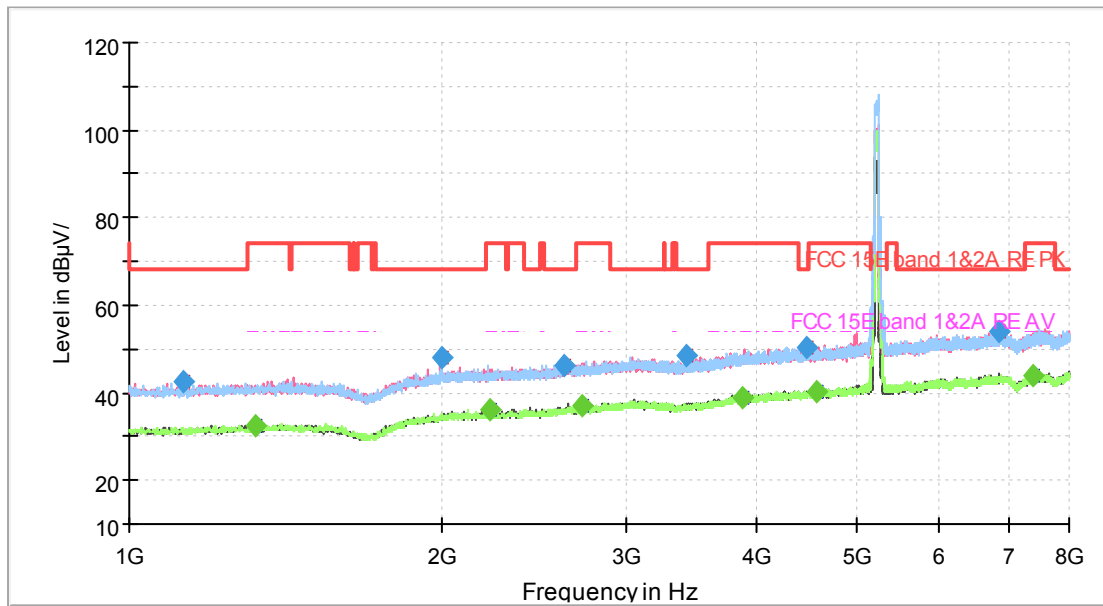

Note: The signal beyond the limit is carrier.
Radiates Emission from 1GHz to 8GHz

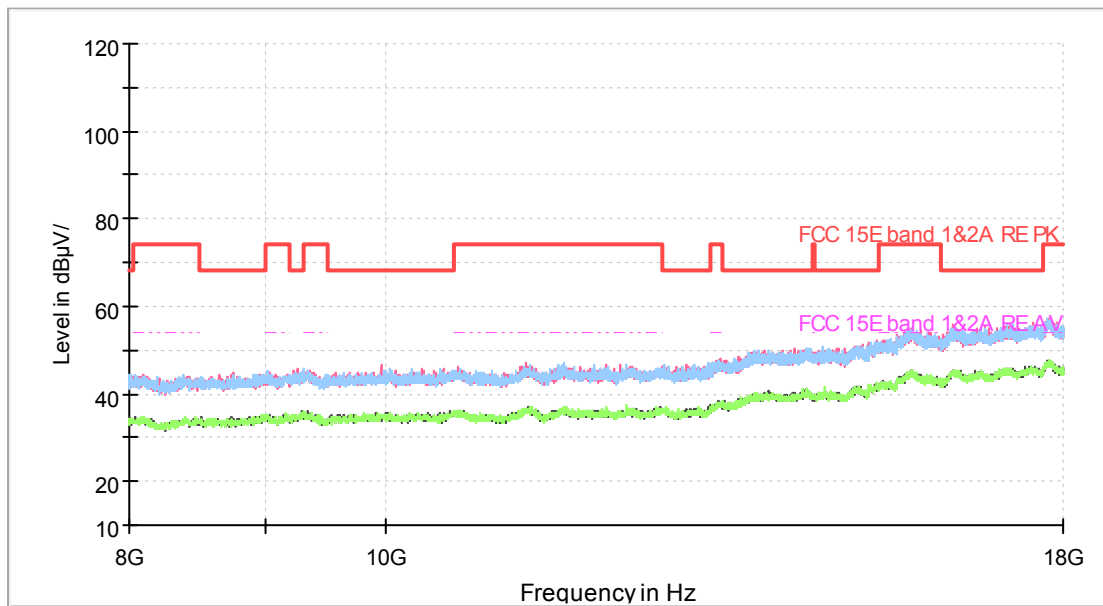

Radiates Emission from 8GHz to 18GHz



Frequency (MHz)	MaxPeak (dB μ V/m)	Average (dB μ V/m)	Limit (dB μ V/m)	Margin (dB)	Height (cm)	Pol	Azimuth (deg)	Corr. (dB/m)
1125.125000	42.32	---	68.20	25.88	100.0	H	41.0	-0.6
1319.375000	---	32.42	54.00	21.58	200.0	V	87.0	0.7
1994.000000	48.10	---	68.20	20.10	200.0	H	338.0	3.8
2217.125000	---	36.05	54.00	17.95	200.0	V	177.0	4.4
2617.000000	46.17	---	68.20	22.03	100.0	H	82.0	5.9
2726.375000	---	37.10	54.00	16.90	200.0	V	221.0	6.8
3426.375000	48.35	---	68.20	19.85	200.0	V	263.0	8.6
3884.875000	---	38.75	54.00	15.25	200.0	V	287.0	10.4
4468.500000	50.11	---	68.20	18.09	200.0	V	144.0	11.6
4580.500000	---	40.03	54.00	13.97	200.0	V	304.0	11.9
6861.625000	54.03	---	68.20	14.17	100.0	H	179.0	16.0
7384.000000	---	44.09	54.00	9.91	100.0	H	74.0	17.2

Remark: 1. Correction Factor = Antenna factor+ Insertion loss (cable loss + amplifier gain)



802.11n (HT40) CH151

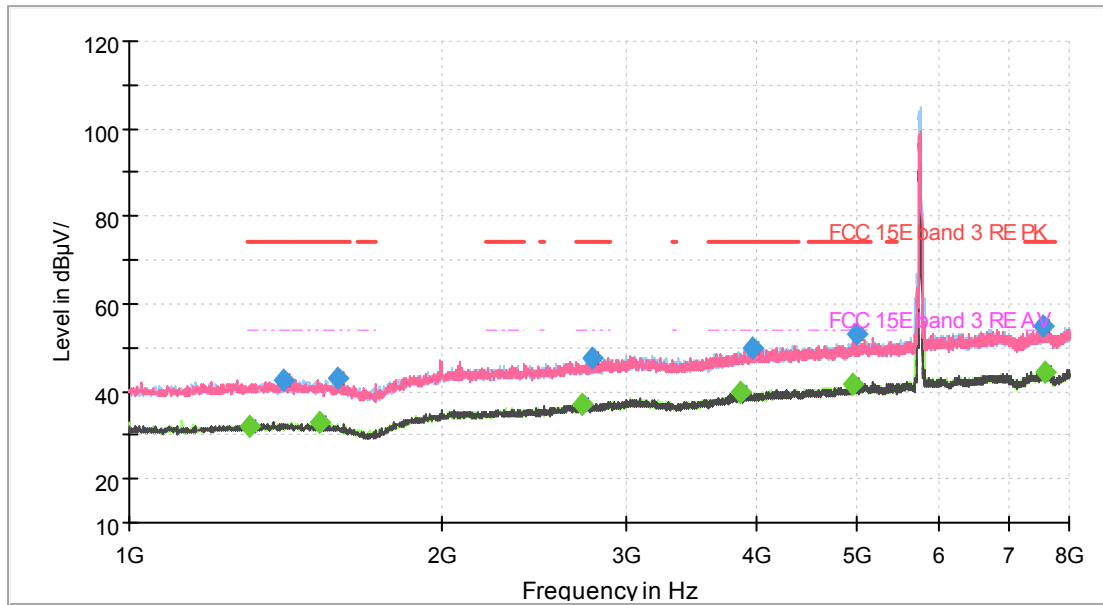

Note: The signal beyond the limit is carrier.
Radiates Emission from 1GHz to 8GHz

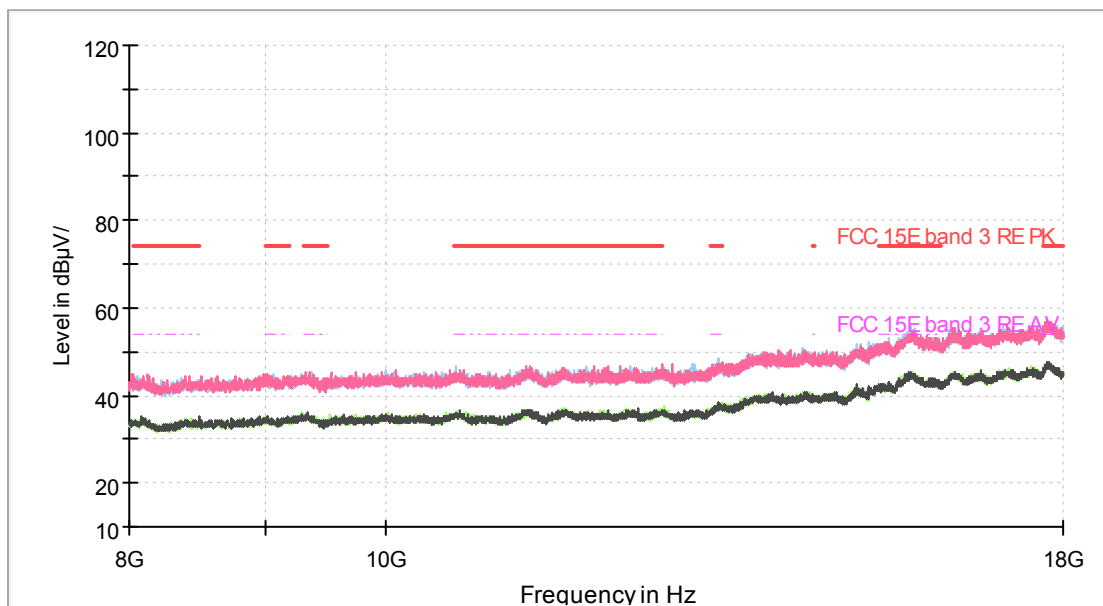

Radiates Emission from 8GHz to 18GHz



Frequency (MHz)	MaxPeak (dB μ V/m)	Average (dB μ V/m)	Limit (dB μ V/m)	Margin (dB)	Height (cm)	Pol	Azimuth (deg)	Corr. (dB/m)
1307.125000	---	32.15	54.00	21.85	100.0	V	54.0	0.6
1406.000000	42.66	---	74.00	31.34	100.0	H	319.0	1.0
1526.750000	---	32.71	54.00	21.29	200.0	V	288.0	1.4
1583.625000	42.82	---	74.00	31.18	100.0	H	80.0	1.8
2718.500000	---	37.24	54.00	16.76	200.0	H	354.0	6.8
2782.375000	47.39	---	74.00	26.61	200.0	V	332.0	6.8
3858.625000	---	39.84	54.00	14.16	200.0	H	0.0	10.3
3974.125000	49.74	---	74.00	24.26	200.0	V	250.0	10.7
4959.375000	---	41.82	54.00	12.18	200.0	H	0.0	13.0
4999.625000	53.04	---	74.00	20.96	100.0	V	5.0	12.9
7563.375000	54.75	---	74.00	19.25	100.0	H	146.0	17.5
7599.250000	---	44.45	54.00	9.55	100.0	V	0.0	17.6

Remark: 1. Correction Factor = Antenna factor+ Insertion loss (cable loss + amplifier gain)



802.11n (HT40) CH159

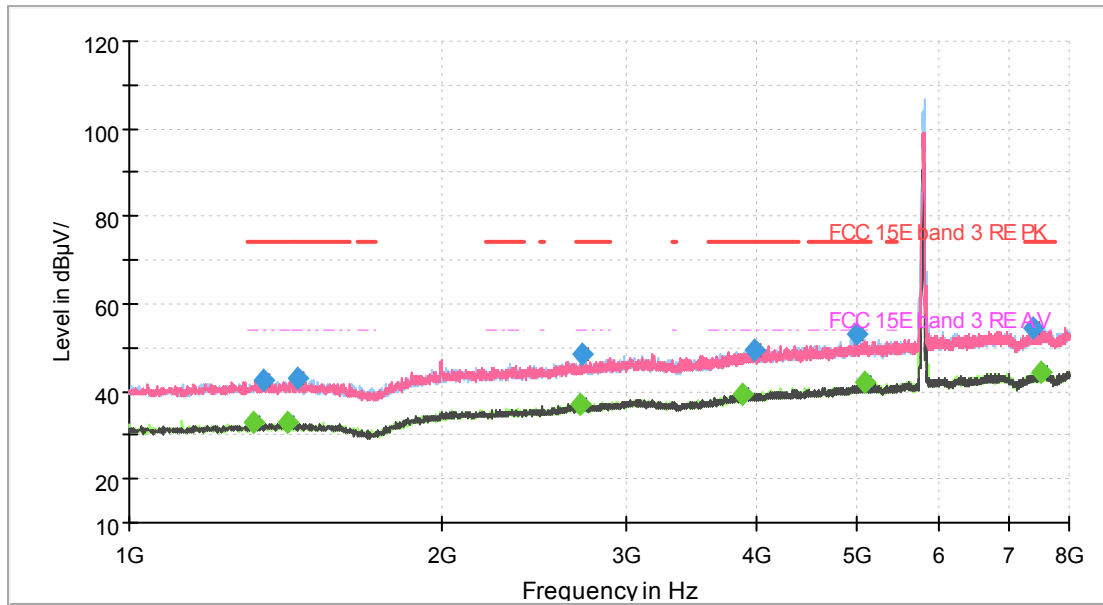

Note: The signal beyond the limit is carrier.
Radiates Emission from 1GHz to 8GHz

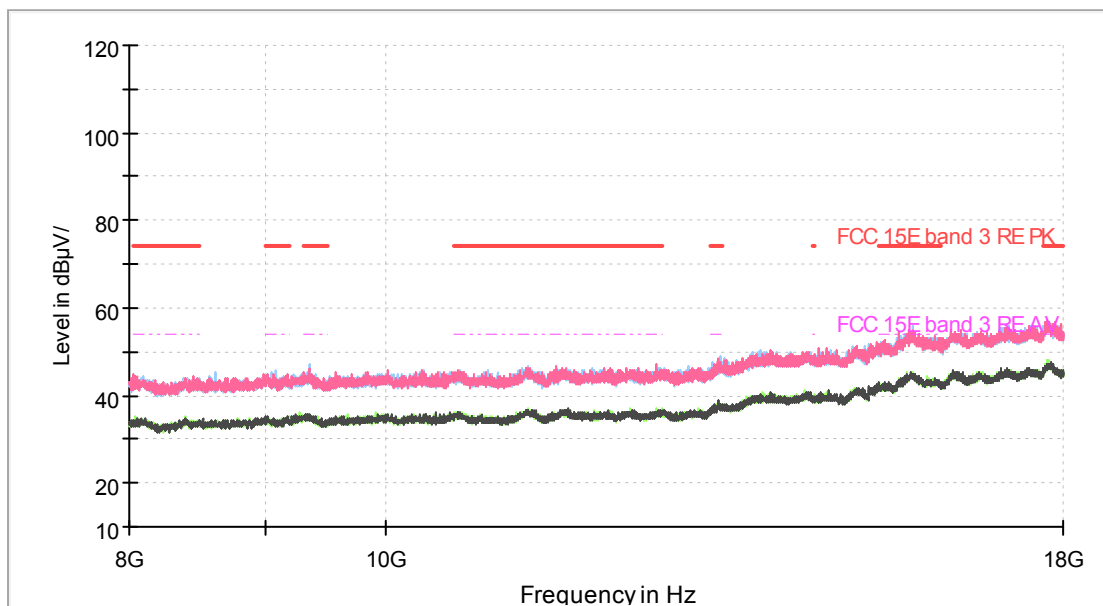

Radiates Emission from 8GHz to 18GHz



Frequency (MHz)	MaxPeak (dB μ V/m)	Average (dB μ V/m)	Limit (dB μ V/m)	Margin (dB)	Height (cm)	Pol	Azimuth (deg)	Corr. (dB/m)
1317.625000	---	32.82	54.00	21.18	200.0	H	0.0	0.7
1347.375000	42.47	---	74.00	31.53	200.0	V	3.0	0.7
1419.125000	---	33.00	54.00	21.00	200.0	V	182.0	1.1
1450.625000	43.03	---	74.00	30.97	100.0	H	11.0	1.2
2715.000000	---	37.24	54.00	16.76	200.0	H	358.0	6.7
2721.125000	48.70	---	74.00	25.30	200.0	H	262.0	6.8
3891.875000	---	39.43	54.00	14.57	200.0	V	245.0	10.4
3989.875000	49.29	---	74.00	24.71	200.0	V	40.0	10.7
4989.125000	53.24	---	74.00	20.76	100.0	V	310.0	12.8
5083.625000	---	41.99	54.00	12.01	100.0	H	334.0	13.5
7381.375000	54.56	---	74.00	19.44	100.0	V	199.0	17.2
7516.125000	---	44.35	54.00	9.65	200.0	V	146.0	17.3

Remark: 1. Correction Factor = Antenna factor+ Insertion loss (cable loss + amplifier gain)



802.11ac (HT80) CH42

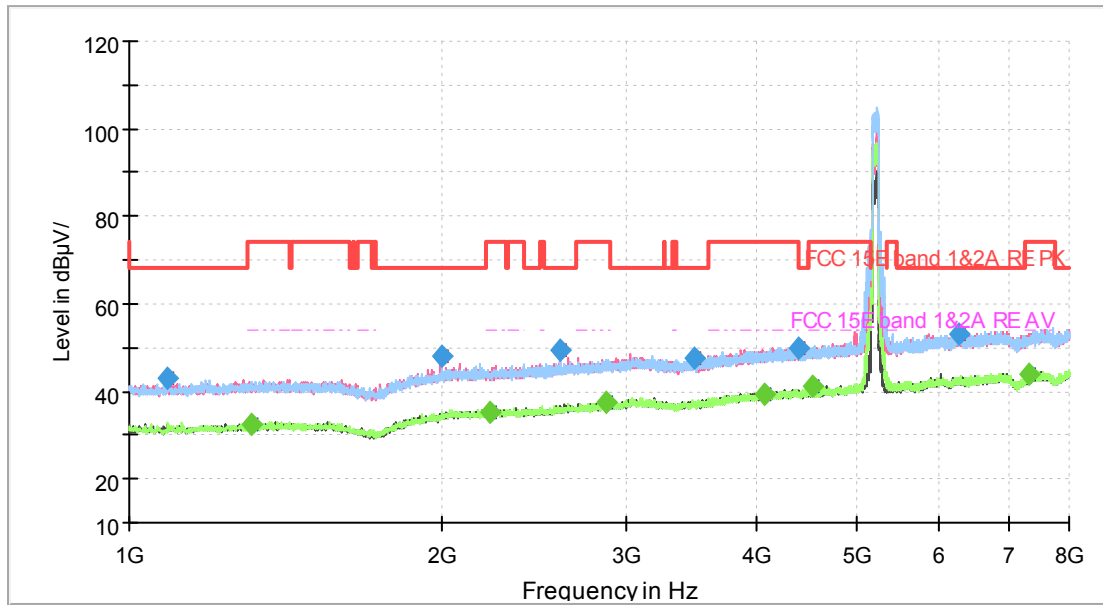

Note: The signal beyond the limit is carrier.
Radiates Emission from 1GHz to 8GHz

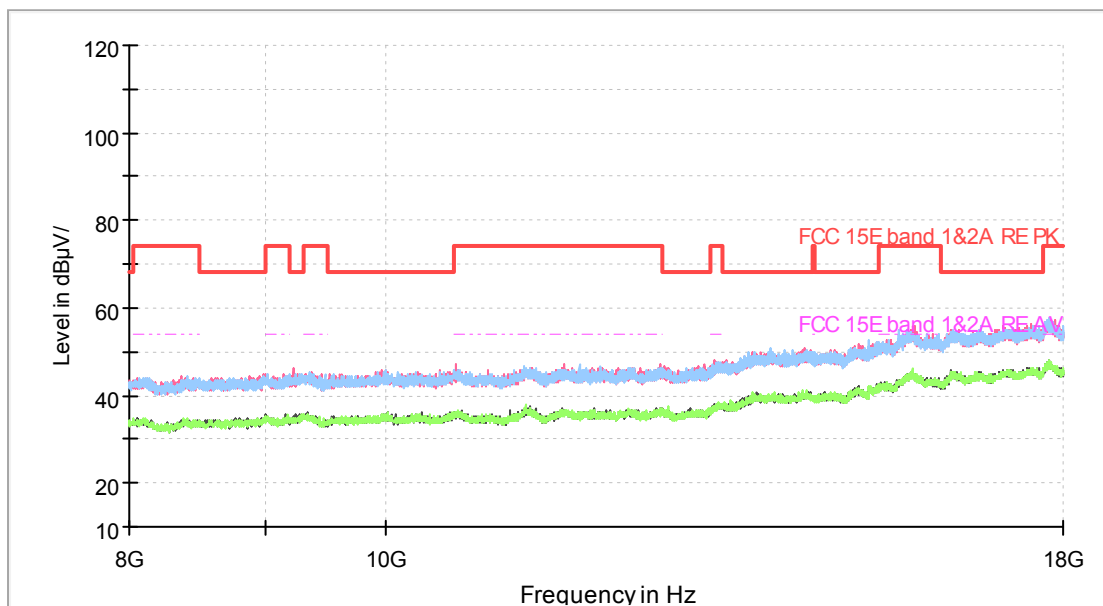

Radiates Emission from 8GHz to 18GHz



Frequency (MHz)	MaxPeak (dB μ V/m)	Average (dB μ V/m)	Limit (dB μ V/m)	Margin (dB)	Height (cm)	Pol	Azimuth (deg)	Corr. (dB/m)
1088.375000	42.78	---	68.20	25.42	100.0	H	0.0	-0.7
1308.875000	---	32.35	54.00	21.65	200.0	H	316.0	0.6
1993.125000	47.98	---	68.20	20.22	200.0	V	16.0	3.8
2217.125000	---	35.23	54.00	18.77	100.0	H	156.0	4.4
2595.125000	49.27	---	68.20	18.93	100.0	V	0.0	5.9
2868.125000	---	37.56	54.00	16.44	200.0	V	336.0	7.5
3499.000000	47.48	---	68.20	20.72	200.0	V	319.0	8.9
4075.625000	---	39.20	54.00	14.80	200.0	V	251.0	10.9
4395.875000	49.96	---	74.00	24.04	100.0	H	0.0	11.3
4540.250000	---	41.15	54.00	12.85	100.0	H	290.0	11.9
6270.125000	53.17	---	68.20	15.03	100.0	V	0.0	15.5
7309.625000	---	43.76	54.00	10.24	200.0	H	0.0	17.0

Remark: 1. Correction Factor = Antenna factor+ Insertion loss (cable loss + amplifier gain)

802.11ac (HT80) CH155

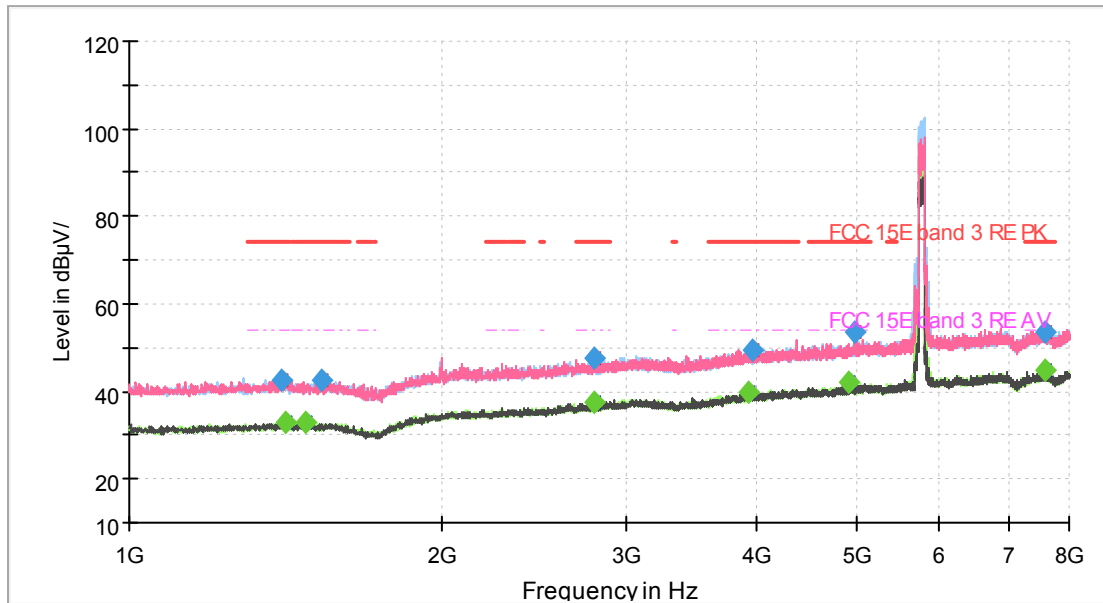

Note: The signal beyond the limit is carrier.
Radiates Emission from 1GHz to 8GHz

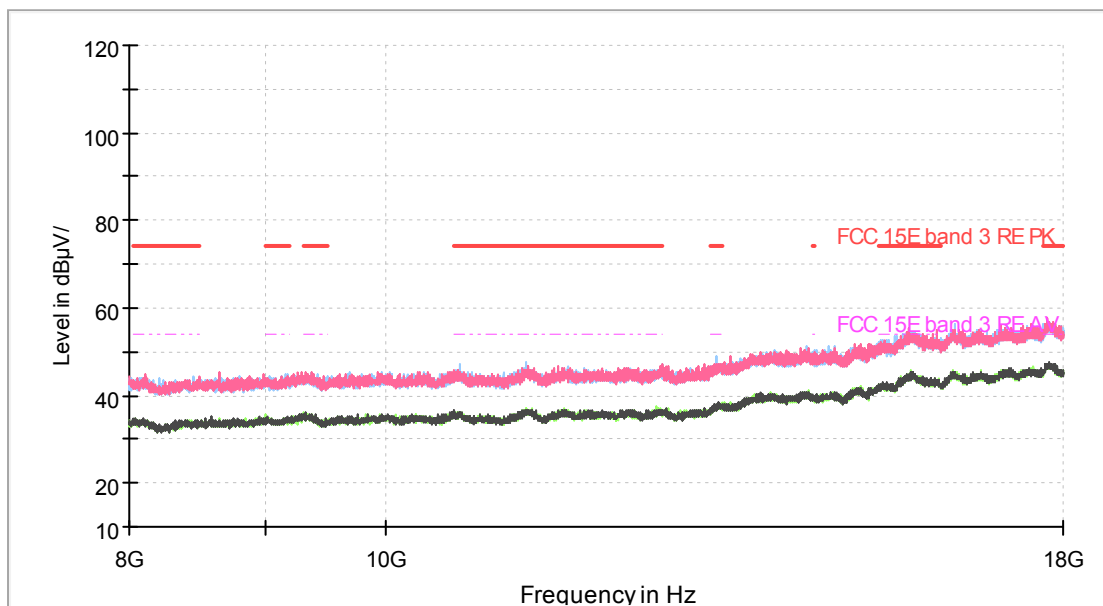

Radiates Emission from 8GHz to 18GHz



Frequency (MHz)	MaxPeak (dB μ V/m)	Average (dB μ V/m)	Limit (dB μ V/m)	Margin (dB)	Height (cm)	Pol	Azimuth (deg)	Corr. (dB/m)
1403.375000	42.77	---	74.00	31.23	200.0	V	149.0	1.0
1410.375000	---	32.70	54.00	21.30	200.0	H	322.0	1.1
1476.000000	---	33.09	54.00	20.91	100.0	H	303.0	1.3
1530.250000	42.63	---	74.00	31.37	200.0	V	149.0	1.4
2794.625000	47.38	---	74.00	26.62	200.0	H	291.0	6.9
2801.625000	---	37.41	54.00	16.59	100.0	V	20.0	7.0
3930.375000	---	39.62	54.00	14.38	100.0	H	103.0	10.6
3961.875000	49.54	---	74.00	24.46	100.0	H	66.0	10.7
4920.875000	---	42.24	54.00	11.76	200.0	V	248.0	12.9
4985.625000	53.72	---	74.00	20.28	100.0	V	313.0	12.9
7571.250000	53.75	---	74.00	20.25	200.0	V	0.0	17.5
7594.875000	---	44.71	54.00	9.29	100.0	V	162.0	17.6

Remark: 1. Correction Factor = Antenna factor+ Insertion loss (cable loss + amplifier gain)

5.6. Conducted Emission

Ambient condition

Temperature	Relative humidity	Pressure
23°C ~25°C	45%~50%	101.5kPa

Methods of Measurement

The EUT IS placed on a non-metallic table of 80cm height above the horizontal metal reference ground plane. During the test, the EUT was operating in its typical mode. The test method is according to ANSI C63.10-2013. Connect the AC power line of the EUT to the LISN Use EMI receiver to detect the average and Quasi-peak value. RBW is set to 9kHz, VBW is set to 30kHz The measurement result should include both L line and N line.

The test is in transmitting mode.

Test Setup

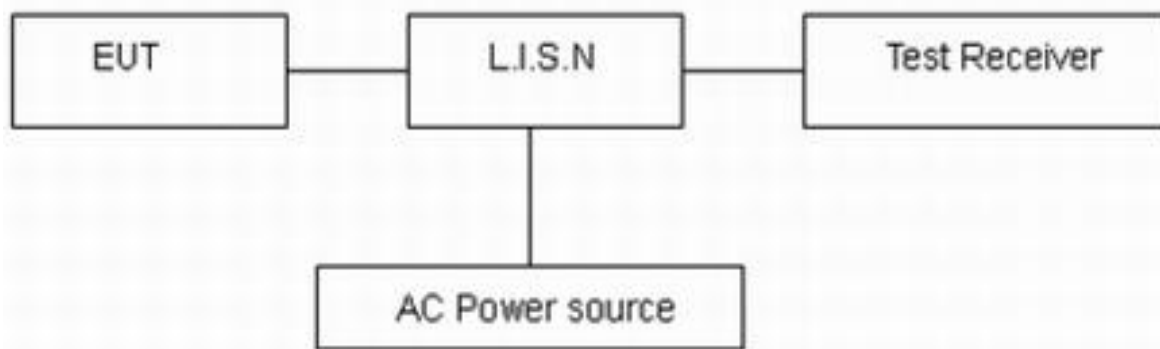

Note: AC Power source is used to change the voltage 110V/60Hz.

Limits

Frequency (MHz)	Conducted Limits(dBμV)	
	Quasi-peak	Average
0.15 - 0.5	66 to 56 *	56 to 46*
0.5 - 5	56	46
5 - 30	60	50

*: Decreases with the logarithm of the frequency.

Measurement Uncertainty

The assessed measurement uncertainty to ensure 95% confidence level for the normal distribution is with the coverage factor $k = 1.96$, $U = 2.69$ dB.

Test Results:

Following plots, Blue trace uses the peak detection and Green trace uses the average detection. During the test, the Conducted Emission was performed in all modes with all channels, 802.11a, Channel 40 are selected as the worst condition. The test data of the worst-case condition was recorded in this report.

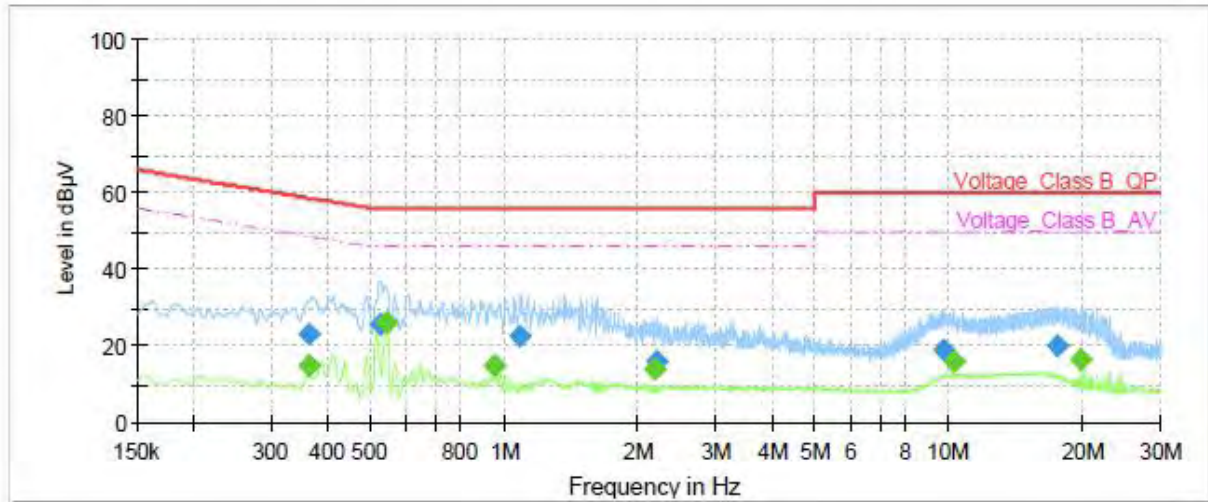

Frequency (MHz)	QuasiPeak (dBµV)	Average (dBµV)	Limit (dBµV)	Margin (dB)	Meas. Time (ms)	Bandwidth (kHz)	Line	Filter	Corr. (dB)
0.36	---	14.85	48.69	33.84	1000.0	9.000	L1	ON	19
0.36	22.92	---	58.69	35.77	1000.0	9.000	L1	ON	19
0.53	25.71	---	56.00	30.29	1000.0	9.000	L1	ON	19
0.54	---	26.33	46.00	19.67	1000.0	9.000	L1	ON	19
0.96	---	15.02	46.00	30.98	1000.0	9.000	L1	ON	19
1.09	22.57	---	56.00	33.43	1000.0	9.000	L1	ON	19
2.18	---	13.66	46.00	32.34	1000.0	9.000	L1	ON	19
2.20	16.13	---	56.00	39.87	1000.0	9.000	L1	ON	19
9.69	19.08	---	60.00	40.92	1000.0	9.000	L1	ON	19
10.25	---	16.01	50.00	33.99	1000.0	9.000	L1	ON	19
17.48	20.16	---	60.00	39.84	1000.0	9.000	L1	ON	20
19.71	---	16.29	50.00	33.71	1000.0	9.000	L1	ON	20

Remark: Correct factor=cable loss + LISN factor

L line Conducted Emission from 150 KHz to 30 MHz

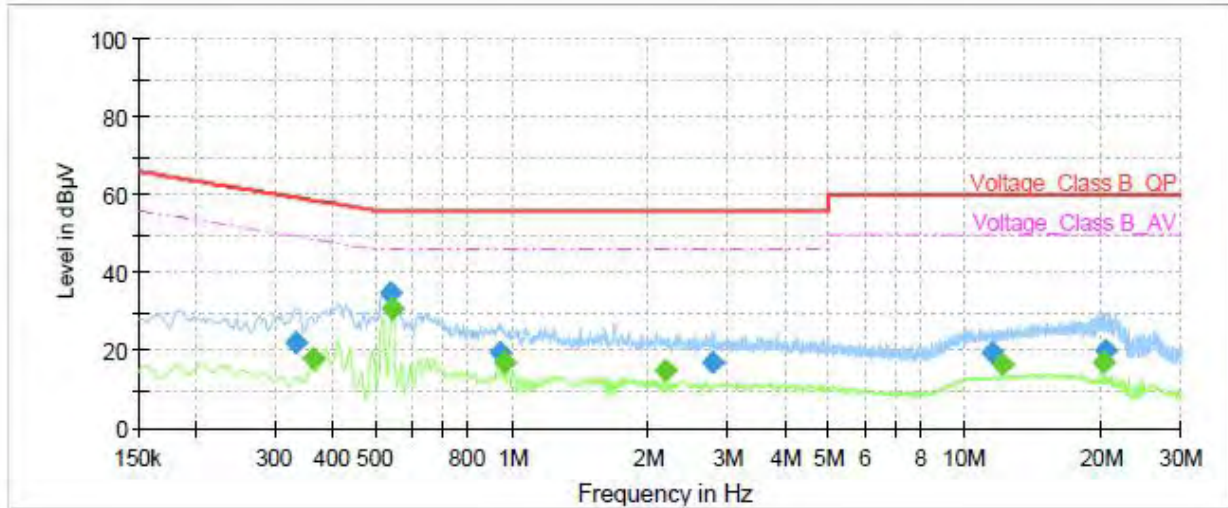

Frequency (MHz)	QuasiPeak (dBµV)	Average (dBµV)	Limit (dBµV)	Margin (dB)	Meas. Time (ms)	Bandwidth (kHz)	Line	Filter	Corr. (dB)
0.33	21.91	---	59.34	37.43	1000.0	9.000	N	ON	19
0.36	---	18.09	48.69	30.60	1000.0	9.000	N	ON	19
0.54	35.10	---	56.00	20.90	1000.0	9.000	N	ON	19
0.54	---	30.66	46.00	15.34	1000.0	9.000	N	ON	19
0.94	19.64	---	56.00	36.36	1000.0	9.000	N	ON	19
0.96	---	16.86	46.00	29.14	1000.0	9.000	N	ON	19
2.18	---	14.96	46.00	31.04	1000.0	9.000	N	ON	19
2.78	17.10	---	56.00	38.90	1000.0	9.000	N	ON	19
11.42	19.28	---	60.00	40.72	1000.0	9.000	N	ON	19
12.15	---	16.16	50.00	33.84	1000.0	9.000	N	ON	19
20.26	---	17.16	50.00	32.84	1000.0	9.000	N	ON	19
20.56	19.76	---	60.00	40.24	1000.0	9.000	N	ON	19

Remark: Correct factor=cable loss + LISN factor

N line Conducted Emission from 150 KHz to 30 MHz



6. Main Test Instruments

Name	Manufacturer	Type	Serial Number	Calibration Date	Expiration Date
Spectrum Analyzer	R&S	FSV40	15195-01-00	2019-05-19	2020-05-18
EMI Test Receiver	R&S	ESCI	100948	2019-05-19	2020-05-18
Loop Antenna	SCHWARZBECK	FMZB1519	1519-047	2017-09-26	2020-09-25
TRILOG Broadband Antenna	SCHWARZBECK	VULB 9163	9163-201	2017-11-18	2020-11-17
Double Ridged Waveguide Horn Antenna	R&S	HF907	100126	2018-07-07	2020-07-06
Standard Gain Horn	ETS-Lindgren	3160-09	00102643	2018-06-20	2020-06-19
Standard Gain Horn	STEATITE	QSH-SL-26-40 -K-15	16779	2017-07-20	2020-07-19
Broadband Horn Antenna	SCHWARZBECK	BBHA 9120D	430	2018-07-07	2020-07-06
EMI Test Receiver	R&S	ESR	101667	2019-05-19	2020-05-18
LISN	R&S	ENV216	101171	2018-12-15	2021-12-14
Spectrum Analyzer	KEYSIGHT	N9020A	MY54420163	2019-12-15	2020-12-14
RF Cable	Agilent	SMA 15cm	0001	2019-12-13	2020-06-12
TEMPERATURE CHAMBER	WEISS	VT4002	582261194500 10	2019-12-15	2020-12-14
AV Power Meter	R&S	NRP	104306	2019-05-19	2020-05-18
Power Probe	R&S	NRP-Z21	104799	2019-05-19	2020-05-18
DC Power Supply	GWINSTEK	GPS-3030D	GEP882653	2019-05-19	2020-05-18
Software	R&S	EMC32	9.26.0	/	/

*****END OF REPORT *****