



RF TEST REPORT

Applicant Shanghai Smawave Technology Co. ,Ltd
FCC ID 2AU8HSRG411-A
Product LTE CPE
Brand Smawave
Model SRG411-a
Report No. R2001A0010-R5V1
Issue Date May 7, 2020

TA Technology (Shanghai) Co., Ltd. tested the above equipment in accordance with the requirements in **FCC CFR47 Part 2 (2019)/ FCC CFR 47 Part 90S (2019)**. The test results show that the equipment tested is capable of demonstrating compliance with the requirements as documented in this report.

Peng Tao

Performed by: Peng Tao

Kai Xu

Approved by: Kai Xu

TA Technology (Shanghai) Co., Ltd.

No.145, Jintang Rd, Tangzhen Industry Park, Pudong Shanghai, China

TEL: +86-021-50791141/2/3

FAX: +86-021-50791141/2/3-8000



TABLE OF CONTENT

- 1. Test Laboratory..... 4
 - 1.1. Notes of the Test Report..... 4
 - 1.2. Test facility..... 4
 - 1.3. Testing Location..... 4
- 2. General Description of Equipment under Test..... 5
 - 2.1. Applicant and Manufacturer Information..... 5
 - 2.2. General Information..... 5
- 3. Applied Standards..... 6
- 4. Test Configuration..... 7
- 5. Test Case Results..... 8
 - 5.1. Radiates Spurious Emission..... 8
- 6. Main Test Instruments..... 13



Summary of measurement results

No.	Test Case	Clause in FCC rules	Verdict
1	Radiates Spurious Emission	2.1053 /90.691	PASS
Date of Testing: February 19, 2020~ March 30, 2020			

Conducted items please refer to the MGL6201A module report (Report No.: R2001A0002-R5V1).

Note: This revised report (Report No.: R2001A0010-R5V1) supersedes and replaces the previously issued report (Report No.:R2001A0010-R5). Please discard or destroy the previously issued report and dispose of it accordingly.



1. Test Laboratory

1.1. Notes of the Test Report

This report shall not be reproduced in full or partial, without the written approval of **TA technology (shanghai) co., Ltd.** The results documented in this report apply only to the tested sample, under the conditions and modes of operation as described herein .Measurement Uncertainties were not taken into account and are published for informational purposes only. This report is written to support regulatory compliance of the applicable standards stated above.

1.2. Test facility

FCC (Designation number: CN1179, Test Firm Registration Number: 446626)

TA Technology (Shanghai) Co., Ltd. has been listed on the US Federal Communications Commission list of test facilities recognized to perform electromagnetic emissions measurements.

A2LA (Certificate Number: 3857.01)

TA Technology (Shanghai) Co., Ltd. has been listed by American Association for Laboratory Accreditation to perform electromagnetic emission measurement.

1.3. Testing Location

Company: TA Technology (Shanghai) Co., Ltd.
Address: No.145, Jintang Rd, Tangzhen Industry Park, Pudong
City: Shanghai
Post code: 201201
Country: P. R. China
Contact: Xu Kai
Telephone: +86-021-50791141/2/3
Fax: +86-021-50791141/2/3-8000
Website: <http://www.ta-shanghai.com>
E-mail: xukai@ta-shanghai.com

2. General Description of Equipment under Test

2.1. Applicant and Manufacturer Information

Applicant	Shanghai Smawave Technology Co. ,Ltd
Applicant address	3/F, Building 8, 1001 North Qinzhou Road, Xuhui District, Shanghai, China
Manufacturer	Shanghai Smawave Technology Co. ,Ltd
Manufacturer address	3/F, Building 8, 1001 North Qinzhou Road, Xuhui District, Shanghai, China

2.2. General Information

EUT Description			
Model	SRG411-a		
SN	1#		
Hardware Version	V1.0		
Software Version	SG625		
Power Supply	DC Power		
Antenna Type	External Antenna		
Antenna Gain	3.18dBi		
Test Mode(s)	LTE Band 26;		
Test Modulation	QPSK 16QAM 64QAM;		
LTE Category	12		
Rated Power Supply Voltage	12V		
Extreme Voltage	Minimum: 9V Maximum: 14V		
Extreme Temperature	Lowest: -40°C Highest: +70°C		
Operating Frequency Range(s)	Band	Tx (MHz)	Rx (MHz)
	LTE Band 26	814 ~ 824	859 ~ 869
Note: 1. The EUT is sent from the applicant to TA and the information of the EUT is declared by the applicant.			



3. Applied Standards

According to the specifications of the manufacturer, it must comply with the requirements of the following standards:

Test standards:

FCC CFR 47 Part 90S (2019)

ANSI C63.26 (2015)

Reference standard:

FCC CFR47 Part 2 (2019)

KDB 971168 D01 Power Meas License Digital Systems v03r01

4. Test Configuration

Radiated measurements are performed by rotating the EUT in three different orthogonal test planes. EUT stand-up position (Z axis), lie-down position (X, Y axis). Receiver antenna polarization (horizontal and vertical), the worst emission was found in position (Z axis, Horizontal polarization) and the worst case was recorded.

All mode and data rates and positions were investigated.

The following testing in LTE is set based on the maximum RF Output Power.

Test modes are chosen as the worst case configuration below for LTE Band 26

Test items	Bandwidth (MHz)					Modulation			RB			Test Channel		
	1.4	3	5	10	15	QPSK	16QAM	64QAM	1	50%	100%	L	M	H
Radiates Spurious Emission	O	-	O	-	O	O	-	-	O	-	-	-	O	-
Note	1. The mark "O" means that this configuration is chosen for testing. 2. The mark "-" means that this configuration is not testing.													

5. Test Case Results

5.1. Radiates Spurious Emission

Ambient condition

Temperature	Relative humidity
21°C ~25°C	40%~60%

Method of Measurement

1. The testing follows FCC KDB 971168 v03r01 Section 5.8 and ANSI C63.26 (2015).
2. Below 1GHz: The EUT is placed on a turntable 0.8 meters above the ground in the chamber, 3 meter away from the antenna. The maximal emission value is acquired by adjusting the antenna height, polarisation and turntable azimuth. Normally, the height range of antenna is 1 m to 4 m, the azimuth range of turntable is 0° to 360°, and the receive antenna has two polarizations Vertical (V) and Horizontal (H). Above 1GHz: (Note: the FCC's permission to use 1.5m as an alternative per TCBC Conf call of Dec. 2, 2014.) The EUT is placed on a turntable 1.5 meters above the ground in the chamber, 3 meter away from the antenna. The maximal emission value is acquired by adjusting the antenna height, polarisation and turntable azimuth. Normally, the height range of antenna is 1 m to 4 m, the azimuth range of turntable is 0° to 360°, and the receive antenna has two polarizations Vertical (V) and Horizontal (H).
3. A loop antenna, A log-periodic antenna or horn antenna shall be substituted in place of the EUT. The log-periodic antenna will be driven by a signal generator and the level will be adjusted till the same power value on the spectrum analyzer or receiver. The level of the spurious emissions can be calculated through the level of the signal generator, cable loss, the gain of the substitution antenna and the reading of the spectrum analyzer or receiver.
4. The EUT is then put into continuously transmitting mode at its maximum power level during the test. Set Test Receiver or Spectrum RBW=200Hz,VBW=600Hz for 9kHz150kHz , RBW=10kHz, VBW=30kHz 150kHz-30MHz , RBW=100kHz,VBW=300kHz for 30MHz to 1GHz and RBW=1MHz, VBW=3MHz for above 1GHz, And the maximum value of the receiver should be recorded as (Pr).
5. The EUT shall be replaced by a substitution antenna. In the chamber, an substitution antenna for the frequency band of interest is placed at the reference point of the chamber. An RF Signal source for the frequency band of interest is connected to the substitution antenna with a cable that has been constructed to not interfere with the radiation pattern of the antenna. A power (PMea) is applied to the input of the substitution antenna, and adjust the level of the signal generator output until the value of the receiver reach the previously recorded (Pr). The power of signal source (PMea) is recorded. The test should be performed by rotating the test item and adjusting the receiving antenna polarization.
6. A amplifier should be connected to the Signal Source output port. And the cable should be connect between the Amplifier and the Substitution Antenna. The cable loss (Pcl) ,the Substitution Antenna Gain (Ga) and the Amplifier Gain (PAg) should be recorded after test.
7. The measurement results are obtained as described below:

Power(EIRP)=PMea- PAg - Pcl + Ga

The measurement results are amend as described below:

Power(EIRP)=P_{Mea}- P_{cl} + G_a

8. This value is EIRP since the measurement is calibrated using an antenna of known gain (2.15 dBi) and known input power. ERP can be calculated from EIRP by subtracting the gain of the dipole, ERP = EIRP-2.15dBi.

The modulation mode and RB allocation refer to section 5.1, using the maximum output power configuration.

Test setup

9KHz ~ 30MHz

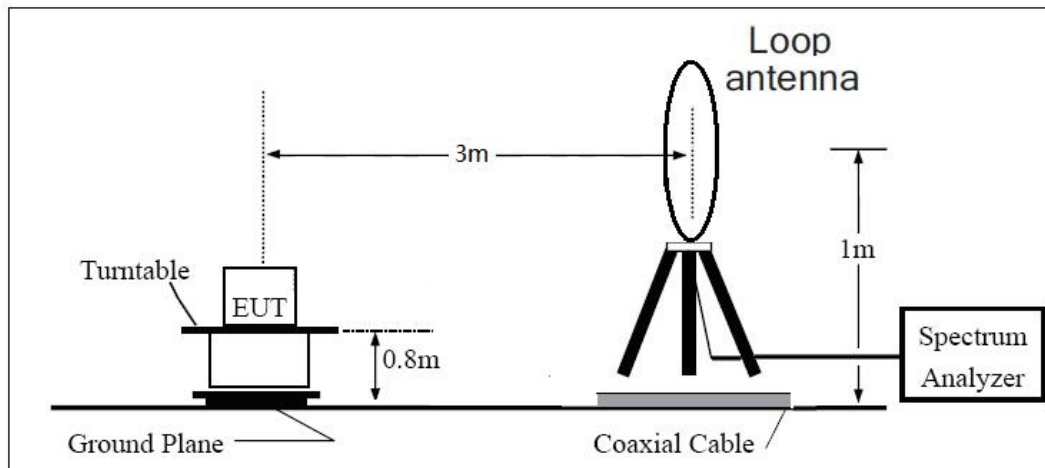

30MHz ~ 1GHz

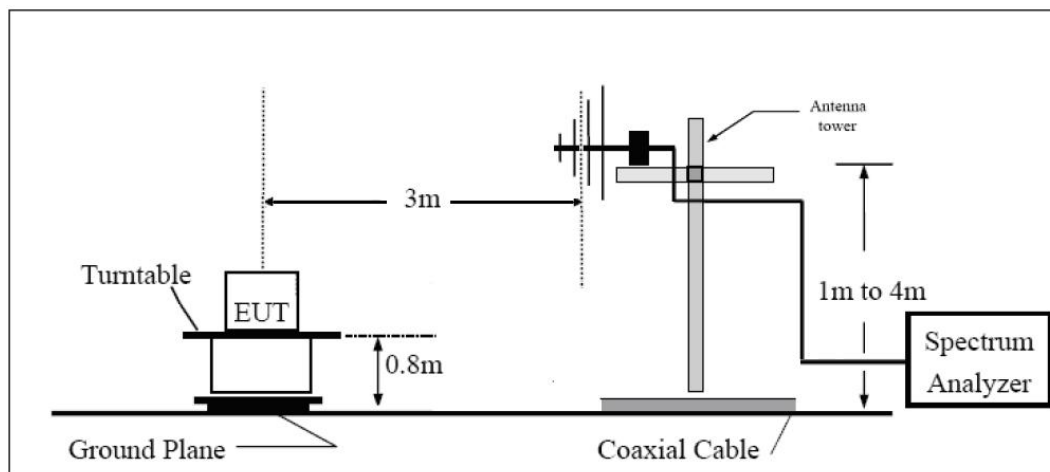

Above 1GHz

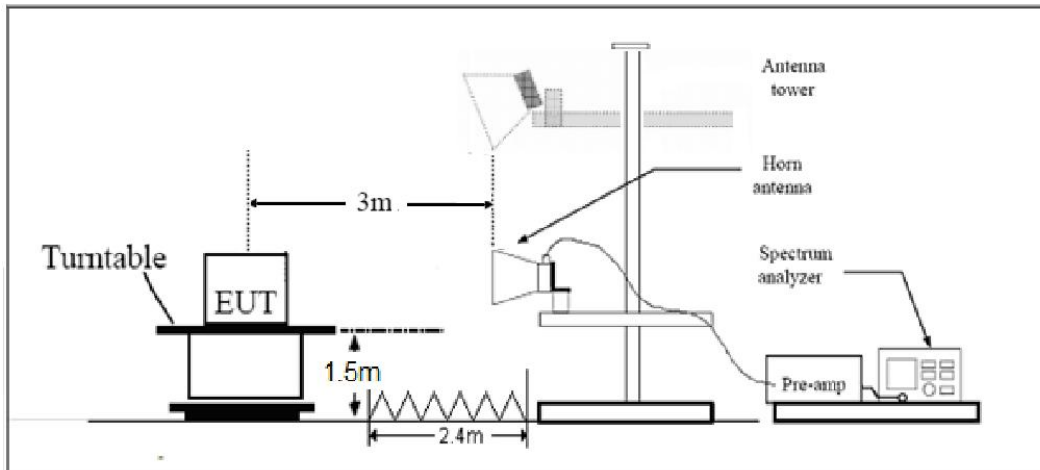

Limits

Rule Part 90.691 specifies that “The power of any emission outside of the authorized operating frequency ranges must be attenuated below the transmitting power (P) by a factor of at least $43 + 10 \log(P)$ dB.”

Limit	-13 dBm
-------	---------

Measurement Uncertainty

The assessed measurement uncertainty to ensure 95% confidence level for the normal distribution is with the coverage factor $k = 1.96$, $U = 3.55$ dB.

**Test Result**

Sweep the whole frequency band through the range from 30MHz to the 10th harmonic of the carrier, the emissions below the noise floor will not be recorded in the report.

LTE Band 26 1.4MHz CH Middle

Harmonic	Frequency (MHz)	SG (dBm)	Cable Loss (dB)	Gain (dBi)	Antenna Polarization	ERP Level (dBm)	Limit (dBm)	Margin (dB)	Azimuth (deg)
2	1638.00	-62.89	2.00	10.75	vertical	-56.29	-13.00	43.29	45
3	2457.00	-63.12	2.51	11.05	vertical	-56.73	-13.00	43.73	315
4	3346.00	-57.04	4.20	11.15	vertical	-52.24	-13.00	39.24	0
5	4182.50	-59.87	5.20	11.15	vertical	-56.07	-13.00	43.07	45
6	5019.00	-56.57	5.50	11.95	vertical	-52.27	-13.00	39.27	90
7	5855.50	-58.13	5.70	13.55	vertical	-52.43	-13.00	39.43	315
8	6692.00	-56.54	6.30	13.75	vertical	-51.24	-13.00	38.24	225
9	7528.50	-55.61	6.80	13.85	vertical	-50.71	-13.00	37.71	45
10	8365.00	-55.29	6.90	14.25	vertical	-50.09	-13.00	37.09	315

Note: 1.The other Spurious RF Radiated emissions level is no more than noise floor.
2.The worst emission was found in the antenna is Horizontal position.

LTE Band 26 5MHz CH Middle

Harmonic	Frequency (MHz)	SG (dBm)	Cable Loss (dB)	Gain (dBi)	Antenna Polarization	ERP Level (dBm)	Limit (dBm)	Margin (dB)	Azimuth (deg)
2	1633.69	-64.34	2.00	10.75	vertical	-57.74	-13.00	44.74	225
3	2450.81	-61.64	2.51	11.05	vertical	-55.25	-13.00	42.25	315
4	3276.00	-61.93	4.20	11.15	vertical	-57.13	-13.00	44.13	90
5	4095.00	-59.10	5.20	11.15	vertical	-55.30	-13.00	42.30	225
6	4914.00	-59.15	5.50	11.95	vertical	-54.85	-13.00	41.85	90
7	5733.00	-59.94	5.70	13.55	vertical	-54.24	-13.00	41.24	45
8	6552.00	-55.73	6.30	13.75	vertical	-50.43	-13.00	37.43	180
9	7371.00	-52.81	6.80	13.85	vertical	-47.91	-13.00	34.91	225
10	8190.00	-53.10	6.90	14.25	vertical	-47.90	-13.00	34.90	270

Note: 1.The other Spurious RF Radiated emissions level is no more than noise floor.
2.The worst emission was found in the antenna is Horizontal position.



LTE Band 26 10MHz CH Middle

Harmonic	Frequency (MHz)	SG (dBm)	Cable Loss (dB)	Gain (dBi)	Antenna Polarization	ERP Level (dBm)	Limit (dBm)	Margin (dB)	Azimuth (deg)
2	1628.81	-65.40	2.00	10.75	vertical	-58.80	-13.00	45.80	180
3	2473.69	-53.89	2.51	11.05	vertical	-47.50	-13.00	34.50	90
4	3276.00	-59.52	4.20	11.15	vertical	-54.72	-13.00	41.72	90
5	4095.00	-57.59	5.20	11.15	vertical	-53.79	-13.00	40.79	0
6	4914.00	-59.31	5.50	11.95	vertical	-55.01	-13.00	42.01	45
7	5733.00	-59.95	5.70	13.55	vertical	-54.25	-13.00	41.25	135
8	6552.00	-57.11	6.30	13.75	vertical	-51.81	-13.00	38.81	45
9	7371.00	-54.26	6.80	13.85	vertical	-49.36	-13.00	36.36	90
10	8190.00	-53.69	6.90	14.25	vertical	-48.49	-13.00	35.49	315

Note: 1.The other Spurious RF Radiated emissions level is no more than noise floor.

2.The worst emission was found in the antenna is Horizontal position.



6. Main Test Instruments

Name	Manufacturer	Type	Serial Number	Calibration Date	Expiration Date
Base Station Simulator	R&S	CMW500	113824	2019-05-19	2020-05-18
Power Splitter	Hua Xiang	SHX-GF2-2-13	10120101	/	/
Spectrum Analyzer	Agilent	N9010A	MY50210259	2019-05-19	2020-05-18
Signal Analyzer	R&S	FSV30	100815	2019-12-16	2020-12-15
Trilog Antenna	SCHWARZBECK	VUBL 9163	01111	2019-09-12	2021-09-11
Horn Antenna	R&S	HF907	100126	2018-07-07	2020-07-06
Signal generator	R&S	SMF 100A	102235	2019-05-19	2020-05-18
Climatic Chamber	ESPEC	SU-242	93000506	2017-12-17	2020-12-16
RF Cable	Agilent	SMA 15cm	0001	2019-06-14	2020-06-13
Software	R&S	EMC32	9.26.0	/	/

*****END OF REPORT *****