



SAR TEST REPORT

Applicant Shanghai Smawave Technology
Co., Ltd

FCC ID 2AU8HSPH310

Product Smart communication terminal

Brand Smawave

Model SPH310

Report No. R2001A0020-S1V1

Issue Date May 11, 2020

TA Technology (Shanghai) Co., Ltd. tested the above equipment in accordance with the requirements in **IEEE 1528-2013, ANSI C95.1: 1992, IEEE C95.1: 1991**. The test results show that the equipment tested is capable of demonstrating compliance with the requirements as documented in this report.

Yu Wang

Guangchang Fan

Performed by: Yu Wang

Approved by: Guangchang Fan

TA Technology (Shanghai) Co., Ltd.

No.145, Jintang Rd, Tangzhen Industry Park, Pudong Shanghai, China

TEL: +86-021-50791141/2/3

FAX: +86-021-50791141/2/3-8000

Table of Contents

1	Test Laboratory.....	3
1.1	Notes of the Test Report	3
1.2.	Test facility	3
1.3	Testing Location.....	3
1.4	Laboratory Environment.....	4
2	Statement of Compliance	5
3	Description of Equipment under Test.....	6
4	Test Specification, Methods and Procedures	8
5	Operational Conditions during Test	9
5.3	Test Positions.....	9
5.3.1	Body Worn Configuration.....	9
5.4	Measurement Variability	10
5.5	Test Configuration	11
5.5.1	LTE Test Configuration.....	11
5.5.2	Additional requirements for TDD LTE specification	12
6	SAR Measurements System Configuration	15
6.3	SAR Measurement Set-up	15
6.4	DASY5 E-field Probe System.....	16
6.5	SAR Measurement Procedure	17
7	Main Test Equipment.....	19
8	Tissue Dielectric Parameter Measurements & System Verification	20
8.3	Tissue Verification.....	20
8.4	System Performance Check.....	22
8.5	SAR System Validation	24
9	Normal and Maximum Output Power	25
9.3	LTE Mode.....	26
10	Measured and Reported (Scaled) SAR Results	36
10.3	EUT Antenna Locations	36
10.4	Measured SAR Results.....	37
11	Measurement Uncertainty	41
	ANNEX A: Test Layout.....	42
	ANNEX B: System Check Results.....	44
	ANNEX C: Highest Graph Results.....	47
	ANNEX D: Probe Calibration Certificate(3677)	51
	ANNEX E: Probe Calibration Certificate(7543).....	62
	ANNEX F: D2450V2 Dipole Calibration Certificate.....	72
	ANNEX G: D2600V2 Dipole Calibration Certificate	80
	ANNEX H: D3700V2 Dipole Calibration Certificate	88
	ANNEX I:DAE4 Calibration Certificate.....	96



1 Test Laboratory

1.1 Notes of the Test Report

This report shall not be reproduced in full or partial, without the written approval of **TA technology (shanghai) co., Ltd.** The results documented in this report apply only to the tested sample, under the conditions and modes of operation as described herein .Measurement Uncertainties were not taken into account and are published for informational purposes only. This report is written to support regulatory compliance of the applicable standards stated above.

1.2. Test facility

FCC (Designation number: CN1179, Test Firm Registration Number: 446626)

TA Technology (Shanghai) Co., Ltd. has been listed on the US Federal Communications Commission list of test facilities recognized to perform electromagnetic emissions measurements.

A2LA (Certificate Number: 3857.01)

TA Technology (Shanghai) Co., Ltd. has been listed by American Association for Laboratory Accreditation to perform electromagnetic emission measurement.

1.3 Testing Location

Company: TA Technology (Shanghai) Co., Ltd.
Address: No.145, Jintang Rd, Tangzhen Industry Park, Pudong Shanghai, China
City: Shanghai
Post code: 201201
Country: P. R. China
Contact: Fan Guangchang
Telephone: +86-021-50791141/2/3
Fax: +86-021-50791141/2/3-8000
Website: <http://www.ta-shanghai.com>
E-mail: fanguangchang@ta-shanghai.com



1.4 Laboratory Environment

Temperature	Min. = 18°C, Max. = 25 °C
Relative humidity	Min. = 30%, Max. = 70%
Ground system resistance	< 0.5 Ω
Ambient noise is checked and found very low and in compliance with requirement of standards. Reflection of surrounding objects is minimized and in compliance with requirement of standards.	

2 Statement of Compliance

The maximum results of Specific Absorption Rate (SAR) found during testing for the EUT are as follows:

Table 1: Highest Reported SAR

Mode	Highest Reported SAR (W/kg)
	Body SAR
LTE TDD 41	1.320
LTE TDD 43	1.091
LTE TDD 48	0.356
LTE TDD 53	0.932
Date of Testing:	March 20, 2020~ March 23, 2020

Note: All indications of Pass/Fail in this report are opinions expressed by TA Technology (Shanghai) Co., Ltd. based on interpretations and/or observations of test results. Measurement Uncertainties were not taken into account and are published for informational purposes only.

Note: This revised report (Report No.: R2001A0020-S1V1) supersedes and replaces the previously issued report (Report No.: R2001A0020-S1). Please discard or destroy the previously issued report and dispose of it accordingly.

3 Description of Equipment under Test

Client Information

Applicant	Shanghai Smawave Technology Co. ,Ltd
Applicant address	3/F, Building 8, 1001 North Qinzhou Road, Xuhui District, Shanghai, China
Manufacturer	Shanghai Smawave Technology Co. ,Ltd
Manufacturer address	3/F, Building 8, 1001 North Qinzhou Road, Xuhui District, Shanghai, China

General Technologies

Application Purpose:	Original Grant
EUT Stage:	Identical Prototype
Model:	SPH310
IMEI:	863134038082221
Hardware Version:	dt863-mb-v0.4
Software Version:	K608_DT863_SPH310_20200414_V9.0
Antenna Type:	Internal Antenna
Device Class:	B
Power Class:	LTE TDD 41/43/48/53:3
Power Level:	LTE TDD 41/43/48/53:max power
Note: The EUT is sent from the applicant to TA and the information of the EUT is declared by the applicant.	

**Wireless Technology and Frequency Range**

Wireless Technology		Modulation	Operating mode	Tx (MHz)
LTE	TDD 41	QPSK, 16QAM, 64QAM	Rel.10/Category 6	2496 ~ 2690
	TDD 43			3600 ~ 3800
	TDD 48			3550 ~ 3700
	TDD 53			2483.5 ~ 2495
Does this device support Carrier Aggregation (CA) <input type="checkbox"/> Yes <input checked="" type="checkbox"/> No				
Does this device support SV-LTE (1xRTT-LTE)? <input type="checkbox"/> Yes <input checked="" type="checkbox"/> No				



4 Test Specification, Methods and Procedures

The tests documented in this report were performed in accordance with FCC 47 CFR § 2.1093, IEEE 1528- 2013, ANSI C95.1: 1992,IEEE C95.1: 1991, the following FCC Published RF exposure KDB procedures:

IEC 62209-1

KDB 447498 D01 General RF Exposure Guidance v06

KDB 648474 D04 Handset SAR v01r03

KDB 690783 D01 SAR Listings on Grants v01r03

KDB 865664 D01 SAR measurement 100 MHz to 6 GHz v01r04

KDB 865664 D02 RF Exposure Reporting v01r02

KDB 941225 D05 SAR for LTE Devices v02r05

KDB 941225 D05A LTE Rel.10 KDB Inquiry Sheet v01r02

5 Operational Conditions during Test

5.3 Test Positions

5.3.1 Body Worn Configuration

Body-worn operating configurations should be tested with the belt-clips and holsters attached to the device and positioned against a flat phantom in normal use configurations.

Per FCC KDB Publication 648474 D04, Body-worn accessory exposure is typically related to voice mode operations when handsets are carried in body-worn accessories. The body-worn accessory procedures in FCC KDB Publication 447498 D01 should be used to test for body-worn accessory SAR compliance, without a headset connected to it. This enables the test results for such configuration to be compatible with that required for hotspot mode when the body-worn accessory test separation distance is greater than or equal to that required for hotspot mode, when applicable. When the reported SAR for a body-worn accessory, measured without a headset connected to the handset, is > 1.2 W/kg, the highest reported SAR configuration for that wireless mode and frequency band should be repeated for that body-worn accessory with a headset attached to the handset.

Accessories for Body-worn operation configurations are divided into two categories: those that do not contain metallic components and those that do contain metallic components. When multiple accessories that do not contain metallic components are supplied with the device, the device is tested with only the accessory that dictates the closest spacing to the body. Then multiple accessories that contain metallic components are tested with the device with each accessory. If multiple accessories share an identical metallic component (i.e. the same metallic belt-clip used with different holsters with no other metallic components) only the accessory that dictates the closest spacing to the body is tested.

Body-worn accessories may not always be supplied or available as options for some devices intended to be authorized for body-worn use. In this case, a test configuration with a separation distance between the back of the device and the flat phantom is used. Test position spacing was documented. Transmitters that are designed to operate in front of a person's face, as in push-to-talk configurations, are tested for SAR compliance with the front of the device positioned to face the flat phantom in head fluid. For devices that are carried next to the body such as a shoulder, waist or chest-worn transmitters, SAR compliance is tested with the accessories, including headsets and microphones, attached to the device and positioned against a flat phantom in a normal use configuration.

5.4 Measurement Variability

Per FCC KDB Publication 865664 D01, SAR measurement variability was assessed for each frequency band, which was determined by the SAR probe calibration point and tissue-equivalent medium used for the device measurements. When both head and body tissue-equivalent media were required for SAR measurements in a frequency band, the variability measurement procedures were applied to the tissue medium with the highest measured SAR, using the highest measured SAR configuration for that tissue-equivalent medium. These additional measurements were repeated after the completion of all measurements requiring the same head or body tissue-equivalent medium in a frequency band. The test device was returned to ambient conditions (normal room temperature) with the battery fully charged before it was re-mounted on the device holder for the repeated measurement(s) to minimize any unexpected variations in the repeated results.

SAR Measurement Variability was assessed using the following procedures for each frequency band:

- 1) When the original highest measured SAR is ≥ 0.80 W/kg, the measurement was repeated once.
- 2) A second repeated measurement was performed only if the ratio of largest to smallest SAR for the original and first repeated measurements was > 1.20 or when the original or repeated measurement was ≥ 1.45 W/kg (~ 10% from the 1-g SAR limit).
- 3) A third repeated measurement was performed only if the original, first or second repeated measurement was ≥ 1.5 W/kg and the ratio of largest to smallest SAR for the original, first and second repeated measurements is > 1.20 .
- 4) Repeated measurements are not required when the original highest measured SAR is < 0.80 W/kg

The same procedures should be adapted for measurements according to extremity and occupational exposure limits by applying a factor of 2.5 for extremity exposure and a factor of 5 for occupational exposure to the corresponding SAR thresholds.

5.5 Test Configuration

5.5.1 LTE Test Configuration

LTE modes were tested according to FCC KDB 941225 D05 publication. Please see notes after the tabulated SAR data for required test configurations. Establishing connections with base station simulators ensure a consistent means for testing SAR and are recommended for evaluating SAR [4]. The R&S CMW500 was used for LTE output power measurements and SAR testing. Max power control was used so the UE transmits with maximum output power during SAR testing. SAR must be measured with the maximum TTI (transmit time interval) supported by the device in each LTE configuration.

A) Spectrum Plots for RB Configurations

A properly configured base station simulator was used for SAR tests and power measurements. Therefore, spectrum plots for RB configurations were not required to be included in this report.

B) MPR

MPR is permanently implemented for this device by the manufacturer. The specific manufacturer target MPR is indicated alongside the SAR results. MPR is enabled for this device, according to 3GPP TS36.101 Section 6.2.3 – 6.2.5 under Table 6.2.3-1.

C)A-MPR

A-MPR (Additional MPR) has been disabled for all SAR tests by setting NS=01 on the base station simulator.

D) Largest channel bandwidth standalone SAR test requirements

1) QPSK with 1 RB allocation

Start with the largest channel bandwidth and measure SAR for QPSK with 1 RB allocation, using the RB offset and required test channel combination with the highest maximum output power for RB offsets at the upper edge, middle and lower edge of each required test channel. When the reported SAR is ≤ 0.8 W/kg, testing of the remaining RB offset configurations and required test channels is not required for 1 RB allocation; otherwise, SAR is required for the remaining required test channels and only for the RB offset configuration with the highest output power for that channel. When the reported SAR of a required test channel is > 1.45 W/kg, SAR is required for all three RB offset configurations for that required test channel.

2) QPSK with 50% RB allocation

The procedures required for 1 RB allocation in 1) are applied to measure the SAR for QPSK with 50% RB allocation.

3) QPSK with 100% RB allocation

For QPSK with 100% RB allocation, SAR is not required when the highest maximum output power for 100 % RB allocation is less than the highest maximum output power in 50% and 1 RB allocations and the highest reported SAR for 1 RB and 50% RB allocation in 1) and 2) are ≤ 0.8 W/kg. Otherwise, SAR is measured for the highest output power channel and if the reported SAR is > 1.45 W/kg, the remaining required test channels must also be tested.

4) Higher order modulations

For each modulation besides QPSK; e.g., 16-QAM, 64-QAM, apply the QPSK procedures in above sections to determine the QAM configurations that may need SAR measurement. For each configuration identified as required for testing, SAR is required only when the highest maximum output power for the configuration in the higher order modulation is $> \frac{1}{2}$ dB higher than the same configuration in QPSK or when the reported SAR for the QPSK configuration is > 1.45 W/kg.

E) Other channel bandwidth standalone SAR test requirements

For the other channel bandwidths used by the device in a frequency band, apply all the procedures required for the largest channel bandwidth in section A) to determine the channels and RB configurations that need SAR testing and only measure SAR when the highest maximum output power of a configuration requiring testing in the smaller channel bandwidth is > 1/2 dB higher than the equivalent channel configurations in the largest channel bandwidth configuration or the reported SAR of a configuration for the largest channel bandwidth is > 1.45 W/kg.

5.5.2 Additional requirements for TDD LTE specification

For Time-Division Duplex (TDD) systems, SAR must be tested using a fixed periodic duty factor according to the highest transmission duty factor implemented for the device and supported by the defined 3GPP LTE TDD configurations.

TDD LTE Band supports 3GPP TS 36.211 section 4.2 for Type 2 Frame Structure and Table: Uplink-downlink configurations for uplink-downlink configurations and Table: Configuration of special subframe (lengths of DwPTS/GP/UpPTS) for Special subframe configurations.

Figure 1: Frame structure type 2

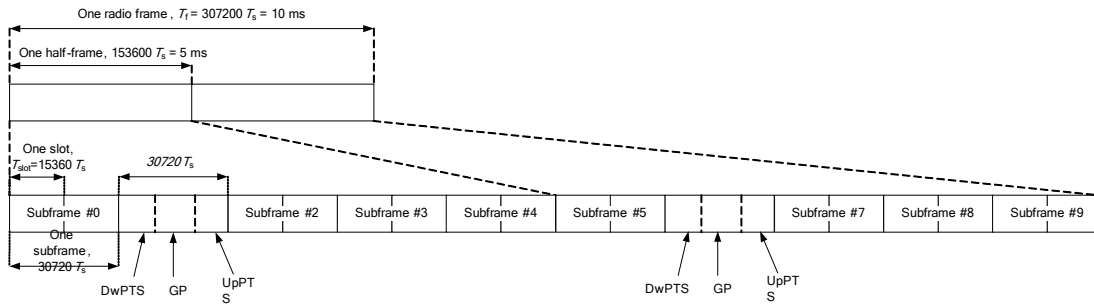

Table 2: Configuration of special subframe (lengths of DwPTS/GP/UpPTS)

Special subframe configuration	Normal cyclic prefix in downlink			Extended cyclic prefix in downlink		
	DwPTS	UpPTS		DwPTS	UpPTS	
		Normal cyclic prefix in uplink	Extended cyclic prefix in uplink		Normal cyclic prefix in uplink	Extended cyclic prefix in uplink
0	$6592 \cdot T_s$	$2192 \cdot T_s$	$2560 \cdot T_s$	$7680 \cdot T_s$	$2192 \cdot T_s$	$2560 \cdot T_s$
1	$19760 \cdot T_s$			$20480 \cdot T_s$		
2	$21952 \cdot T_s$			$23040 \cdot T_s$		
3	$24144 \cdot T_s$			$25600 \cdot T_s$		
4	$26336 \cdot T_s$	$4384 \cdot T_s$	$5120 \cdot T_s$	$7680 \cdot T_s$	$4384 \cdot T_s$	$5120 \cdot T_s$
5	$6592 \cdot T_s$			$20480 \cdot T_s$		
6	$19760 \cdot T_s$			$23040 \cdot T_s$		
7	$21952 \cdot T_s$			$12800 \cdot T_s$		
8	$24144 \cdot T_s$	-	-	-	-	-
9	$13168 \cdot T_s$	-	-	-	-	-

Table 3: Uplink-downlink configurations



Uplink-downlink configuration	Downlink-to-Uplink Switch-point periodicity	Subframe number									
		0	1	2	3	4	5	6	7	8	9
0	5 ms	D	S	U	U	U	D	S	U	U	U
1	5 ms	D	S	U	U	D	D	S	U	U	D
2	5 ms	D	S	U	D	D	D	S	U	D	D
3	10 ms	D	S	U	U	U	D	D	D	D	D
4	10 ms	D	S	U	U	D	D	D	D	D	D
5	10 ms	D	S	U	D	D	D	D	D	D	D
6	5 ms	D	S	U	U	U	D	S	U	U	D

According to Figure 1, one radio frame is configured by 10 subframes, which consist of Uplink-subframe, Downlink-subframe and Special subframe. For TDD-LTE, the Duty Cycle should be calculated on Uplink-subframes and Special subframes, due to Special subframe containing both Uplink transmissions. So for one radio frame, Duty Cycle can be calculated with formula as below. The count of Uplink subframes are according to Table: Uplink-downlink configurations:

$$\text{Duty cycle} = (30720Ts * \text{Ups} + \text{Uplink Component} * \text{Specials}) / (307200Ts)$$

About the uplink component of Special subframes, we can figure out by Table: Configuration of special subframe (lengths of DwPTS/GP/UpPTS):

$$\text{Uplink Component} = \text{UpPTS}$$

In conclusion, for the TDD LTE Band, Duty Cycle can be calculated with formula as below .all these sets are ok when we test, or we can set as below.

$$\text{Duty cycle} = [(30720Ts * \text{Ups}) + \text{UpPTS} * \text{Specials}] / (307200Ts)$$

And we can get different Duty cycles under different configurations:

Uplink-downlink configuration	Subframe number			Configuration of special subframe							
				Normal cyclic prefix in downlink				Extended cyclic prefix in downlink			
	D	S	U	Normal cyclic prefix in uplink		Extended cyclic prefix in uplink		Normal cyclic prefix in uplink		Extended cyclic prefix in uplink	
				configuration 0~4	configuration 5~9	configuration 0~4	configuration 5~9	configuration 0~3	configuration 4~7	configuration 0~3	configuration 4~7
0	2	2	6	61.43%	62.85%	61.67%	63.33%	61.43%	62.85%	61.67%	63.33%
1	4	2	4	41.43%	42.85%	41.67%	43.33%	41.43%	42.85%	41.67%	43.33%
2	6	2	2	21.43%	22.85%	21.67%	23.33%	21.43%	22.85%	21.67%	23.33%
3	6	1	3	30.71%	31.43%	30.83%	31.67%	30.71%	31.43%	30.83%	31.67%
4	7	1	2	20.71%	21.43%	20.83%	21.67%	20.71%	21.43%	20.83%	21.67%
5	8	1	1	10.71%	11.43%	10.83%	11.67%	10.71%	11.43%	10.83%	11.67%
6	3	2	5	51.43%	52.85%	51.67%	53.33%	51.43%	52.85%	51.67%	53.33%

SAR test Plan: For TDD LTE, SAR should be tested with the highest transmission duty factor (63.33%) using Uplink-downlink configuration 0 and Special subframe configuration 7 for Frame structure type

The screenshot displays the 'LTE Signaling - Configuration' window. The 'Physical Cell Setup' section is highlighted with a red box. Within this section, the 'TDD' sub-section is also highlighted with a red box. The 'Use Carrier Specific' checkbox is checked, and the 'Uplink Downlink Configur...' dropdown is set to '0'. Below this, a table shows subframe directions for subframes 0 through 9:

Subframe Number	Direction
0	↓
1	S ↑
2	↑
3	↑
4	↑
5	↓
6	S ↑
7	↑
8	↑
9	↑

On the right side of the interface, the 'LTE Signaling' status is shown as 'ON' in a blue box with a yellow 'ON' indicator.

6 SAR Measurements System Configuration

6.3 SAR Measurement Set-up

The DASY system for performing compliance tests consists of the following items:

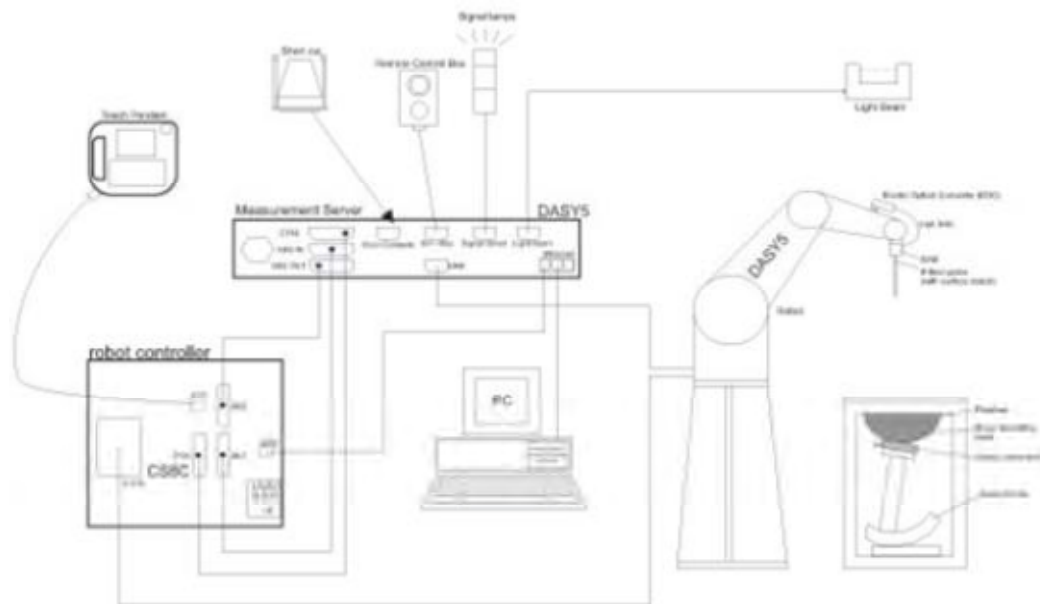

- A standard high precision 6-axis robot with controller, teach pendant and software. An arm extension for accommodating the data acquisition electronics (DAE).
- An isotropic Field probe optimized and calibrated for the targeted measurement.
- A data acquisition electronics (DAE) which performs the signal amplification, signal multiplexing, AD-conversion, offset measurements, mechanical surface detection, collision detection, etc. The unit is battery powered with standard or rechargeable batteries. The signal is optically transmitted to the EOC.
- The Electro-optical converter (EOC) performs the conversion from optical to electrical signals for the digital communication to the DAE. To use optical surface detection, a special version of the EOC is required. The EOC signal is transmitted to the measurement server.
- The function of the measurement server is to perform the time critical tasks such as signal filtering, control of the robot operation and fast movement interrupts.
- The Light Beam used is for probe alignment. This improves the (absolute) accuracy of the probe positioning.
- A computer running WinXP or Win7 and the DASY software.
- Remote control and teach pendant as well as additional circuitry for robot safety such as warning lamps, etc.
- The phantom, the device holder and other accessories according to the targeted measurement.

6.4 DASY5 E-field Probe System

The SAR measurements were conducted with the dosimetric probe EX3DV4 (manufactured by SPEAG), designed in the classical triangular configuration and optimized for dosimetric evaluation.

EX3DV4 Probe Specification

Construction	Symmetrical design with triangular core Built-in shielding against static charges PEEK enclosure material (resistant to organic solvents, e.g., DGBE)
Calibration	ISO/IEC 17025 calibration service available
Frequency	10 MHz to > 6 GHz Linearity: ± 0.2 dB (30 MHz to 6 GHz)
Directivity	± 0.3 dB in HSL (rotation around probe axis) ± 0.5 dB in tissue material (rotation normal to probe axis)
Dynamic Range	10 μ W/g to > 100 mW/g Linearity: ± 0.2 dB (noise: typically < 1 μ W/g)
Dimensions	Overall length: 330 mm (Tip: 20 mm) Tip diameter: 2.5 mm (Body: 12 mm) Typical distance from probe tip to dipole centers: 1 mm
Application	High precision dosimetric measurements in any exposure Scenario (e.g., very strong gradient fields). Only probe which enables compliance testing for frequencies up to 6 GHz with precision of better 30%.



E-field Probe Calibration

Each probe is calibrated according to a dosimetric assessment procedure with accuracy better than $\pm 10\%$. The spherical isotropy was evaluated and found to be better than ± 0.25 dB. The sensitivity parameters (NormX, NormY, NormZ), the diode compression parameter (DCP) and the conversion factor (ConvF) of the probe are tested.

The free space E-field from amplified probe outputs is determined in a test chamber. This is performed in a TEM cell for frequencies below 1 GHz, and in a wave guide above 1 GHz for free space. For the free space calibration, the probe is placed in the volumetric center of the cavity and at the proper orientation with the field. The probe is then rotated 360 degrees.

E-field temperature correlation calibration is performed in a flat phantom filled with the appropriate simulated brain tissue. The measured free space E-field in the medium correlates to temperature rise in a dielectric medium. For temperature correlation calibration a RF transparent thermistor-based temperature probe is used in conjunction with the E-field probe.

$$SAR=C\Delta T/\Delta t$$

Where: Δt = Exposure time (30 seconds),
 C = Heat capacity of tissue (brain or muscle),
 ΔT = Temperature increase due to RF exposure.

Or

$$SAR=IEI^2\sigma/\rho$$

Where: σ = Simulated tissue conductivity,
 ρ = Tissue density (kg/m³).

6.5 SAR Measurement Procedure

Power Reference Measurement

The Power Reference Measurement and Power Drift Measurements are for monitoring the power drift of the device under test in the batch process. The minimum distance of probe sensors to surface determines the closest measurement point to phantom surface. This distance cannot be smaller than the distance of sensor calibration points to probe tip as defined in the probe properties.

Area Scan

The area scan is used as a fast scan in two dimensions to find the area of high field values, before doing a fine measurement around the hot spot. The sophisticated interpolation routines implemented in DASY software can find the maximum found in the scanned area, within a range of the global maximum. The range (in dB) is specified in the standards for compliance testing. For example, a 2 dB range is required in IEEE standard 1528 and IEC 62209 standards, whereby 3 dB is a requirement when compliance is assessed in accordance with the ARIB standard (Japan), if only one zoom scan follows the area scan, then only the absolute maximum will be taken as reference. For cases where multiple maximums are detected, the number of zoom scans has to be increased accordingly.

Area scan parameters extracted from FCC KDB 865664 D01 SAR measurement 100 MHz to 6 GHz.

	≤3 GHz	> 3 GHz
Maximum distance from closest measurement point (geometric center of probe sensors) to phantom surface	5 ± 1 mm	½·δ·ln(2) ± 0.5 mm
Maximum probe angle from probe axis to phantom surface normal at the measurement location	30° ± 1°	20° ± 1°
Maximum area scan spatial resolution: ΔxArea, ΔyArea	≤ 2 GHz: ≤ 15 mm 2 – 3 GHz: ≤ 12 mm	3 – 4 GHz: ≤ 12 mm 4 – 6 GHz: ≤ 10 mm
	When the x or y dimension of the test device, in the measurement plane orientation, is smaller than the above, the measurement resolution must be ≤ the corresponding x or y dimension of the test device with at least one measurement point on the test device.	

Zoom Scan

Zoom scans are used to assess the peak spatial SAR values within a cubic averaging volume containing 1 gram and 10 gram of simulated tissue. The zoom scan measures points (refer to table below) within a cube whose base faces are centered on the maxima found in a preceding area scan job within the same procedure. When the measurement is done, the zoom scan evaluates the averaged SAR for 1 gram and 10 gram and displays these values next to the job's label.

Zoom scan parameters extracted from FCC KDB 865664 D01 SAR measurement 100 MHz to 6 GHz.

			≤3GHz	> 3 GHz
Maximum zoom scan spatial resolution: $\Delta x_{zoom} \Delta y_{zoom}$			≤2GHz: ≤8mm 2 – 3GHz: ≤5mm*	3 – 4GHz: ≤5mm* 4 – 6GHz: ≤4mm*
Maximum zoom scan spatial resolution, normal to phantom surface	Uniform grid: $\Delta z_{zoom}(n)$		≤5mm	3 – 4GHz: ≤4mm 4 – 5GHz: ≤3mm 5 – 6GHz: ≤2mm
	Graded grid	$\Delta z_{zoom}(1)$: between 1 st two points closest to phantom surface	≤4mm	3 – 4GHz: ≤3mm 4 – 5GHz: ≤2.5mm 5 – 6GHz: ≤2mm
		$\Delta z_{zoom}(n > 1)$: between subsequent points	≤1.5 • $\Delta z_{zoom}(n-1)$	
Minimum zoom scan volume	X, y, z		≥30mm	3 – 4GHz: ≥28mm 4 – 5GHz: ≥25mm 5 – 6GHz: ≥22mm
<p>Note: δ is the penetration depth of a plane-wave at normal incidence to the tissue medium; see draft standard IEEE P1528-2011 for details.</p> <p>* When zoom scan is required and the <i>reported</i> SAR from the <i>area scan based 1-g SAR estimation</i> procedures of KDB 447498 is ≤ 1.4W/kg, ≤8mm, ≤7mm and ≤5mm zoom scan resolution may be applied, respectively, for 2GHz to 3GHz, 3GHz to 4GHz and 4GHz to 6GHz.</p>				

Volume Scan Procedures

The volume scan is used for assess overlapping SAR distributions for antennas transmitting in different frequency bands. It is equivalent to an oversized zoom scan used in standalone measurements. The measurement volume will be used to enclose all the simultaneous transmitting antennas. For antennas transmitting simultaneously in different frequency bands, the volume scan is measured separately in each frequency band. In order to sum correctly to compute the 1g aggregate SAR, the EUT remain in the same test position for all measurements and all volume scan use the same spatial resolution and grid spacing. When all volume scan were completed, the software, SEMCAD postprocessor can combine and subsequently superpose these measurement data to calculating the multiband SAR.

Power Drift Monitoring

All SAR testing is under the EUT install full charged battery and transmit maximum output power. In DASY measurement software, the power reference measurement and power drift measurement procedures are used for monitoring the power drift of EUT during SAR test. Both these procedures measure the field at a specified reference position before and after the SAR testing. The software will calculate the field difference in dB. If the power drifts more than 5%, the SAR will be retested.



7 Main Test Equipment

Name of Equipment	Manufacturer	Type/Model	Serial Number	Last Cal.	Cal. Due Date
Network analyzer	Agilent	E5071B	MY42404014	2019-05-19	2020-05-18
Wireless Communication Tester	Anritsu	MT8821C	6201538758	2019-10-17	2020-10-16
Dielectric Probe Kit	HP	85070E	US44020115	2019-05-19	2020-05-18
Power meter	Agilent	E4417A	GB41291714	2019-05-19	2020-05-18
Power sensor	Agilent	N8481H	MY50350004	2019-05-19	2020-05-18
Power sensor	Agilent	E9327A	US40441622	2019-05-19	2020-05-18
Dual directional coupler	Agilent	777D	50146	2019-05-19	2020-05-18
Amplifier	INDEXSAR	IXA-020	0401	2019-05-19	2020-05-18
Wireless communication tester	Anritsu	MT8820C	6201342015	2019-05-19	2020-05-18
Wideband radio communication tester	R&S	CMW 500	113645	2019-05-19	2020-05-18
E-field Probe	SPEAG	EX3DV4	3677	2019-06-19	2020-06-18
E-field Probe	SPEAG	EX3DV4	7543	2019-08-05	2020-08-04
DAE	SPEAG	DAE4	1317	2019-10-23	2020-10-22
Validation Kit 2450MHz	SPEAG	D2450V2	786	2017-08-29	2020-08-28
Validation Kit 2600MHz	SPEAG	D2600V2	1025	2018-05-02	2021-05-01
Validation Kit 3700MHz	SPEAG	D3700V2	1048	2019-08-20	2020-08-19
Temperature Probe	Tianjin jinming	JM222	AA1009129	2019-05-19	2020-05-18
Hygrothermograph	Anymetr	NT-311	20150731	2019-05-19	2020-05-18
Software for Test	Speag	DASY5	/	/	/
Softwarefor Tissue	Agilent	85070	/	/	/

8 Tissue Dielectric Parameter Measurements & System Verification

8.3 Tissue Verification

The temperature of the tissue-equivalent medium used during measurement must also be within 18°C to 25°C and within $\pm 2^\circ\text{C}$ of the temperature when the tissue parameters are characterized. The dielectric parameters must be measured before the tissue-equivalent medium is used in a series of SAR measurements. The parameters should be re-measured after each 3 – 4 days of use; or earlier if the dielectric parameters can become out of tolerance.

Target values

Frequency (MHz)	Water (%)	Salt (%)	Sugar (%)	Glycol (%)	Preventol (%)	Cellulose (%)	ϵ_r	$\sigma(\text{s/m})$
2450	62.70	0.50	0	36.80	0	0	39.2	1.80
2600	55.242	0.306	0	44.452	0	0	39.0	1.96
3700	71.88	0.16	0	37.90	0	0	37.7	3.12

Measurements results

Frequency (MHz)	Test Date	Temp °C	Measured Dielectric Parameters		Target Dielectric Parameters		Limit (Within ±5%)	
			ϵ_r	σ (s/m)	ϵ_r	σ (s/m)	Dev ϵ_r (%)	Dev σ (%)
2450	3/20/2020	21.5	38.6	1.81	39.2	1.80	-1.53	0.56
2600	3/21/2020	21.5	38.2	2.01	39.0	1.96	-2.05	2.55
3700	3/23/2020	21.5	37.9	3.03	37.7	3.12	0.53	-2.88

Note: The depth of tissue-equivalent liquid in a phantom must be ≥ 15.0 cm for SAR measurements ≤ 3 GHz and ≥ 10.0 cm for measurements > 3 GHz.

8.4 System Performance Check

The manufacturer calibrates the probes annually. Dielectric parameters of the tissue simulates were measured using the dielectric probe kit and the network analyzer. A system check measurement for every day was made following the determination of the dielectric parameters of the Tissue simulates, using the dipole validation kit. The dipole antenna was placed under the flat section of the twin SAM phantom.

System check is performed regularly on all frequency bands where tests are performed with the DASY system.

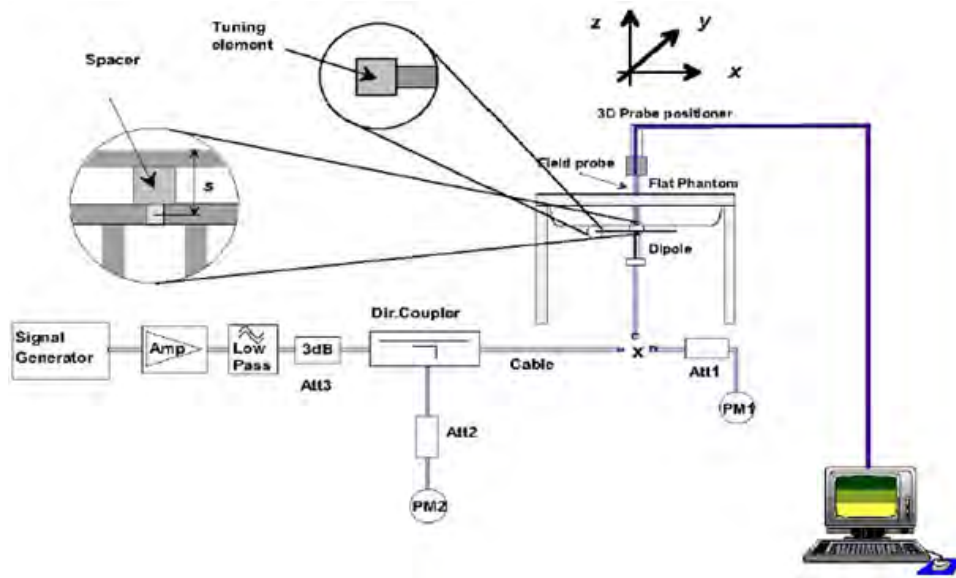

Picture 1 System Performance Check setup



Picture 2 Setup Photo

**Justification for Extended SAR Dipole Calibrations**

Usage of SAR dipoles calibrated less than 3 years ago but more than 1 year ago were confirmed in maintaining return loss (< -20 dB, within 20% of prior calibration) and impedance (within 5 ohm from prior calibration) requirements per extended calibrations in KDB 865664 D01:

Dipole		Date of Measurement	Return Loss(dB)	Δ %	Impedance (Ω)	$\Delta\Omega$
Dipole D2450V2 SN: 786	Head Liquid	8/29/2017	-25.5	/	53.4	/
		8/28/2018	-23.0	10.9	57.2	-3.8
		8/27/2019	-22.2	3.6	56.4	0.8
Dipole D2600V2 SN: 1025	Head Liquid	5/2/2018	-22.0	/	48.1	/
		5/1/2019	-22.5	-2.2	48.7	-0.6

System Check results

Frequency (MHz)	Test Date	Temp $^{\circ}\text{C}$	250mW Measured SAR_{1g} (W/kg)	1W Normalized SAR_{1g} (W/kg)	1W Target SAR_{1g} (W/kg)	Δ % (Limit $\pm 10\%$)	Plot No.
2450	3/20/2020	21.5	13.70	54.80	52.60	4.18	1
2600	3/21/2020	21.5	13.90	55.60	54.10	2.77	2
3700	3/23/2020	21.5	6.83	68.30	67.20	1.64	3

Note: Target Values used derive from the calibration certificate Data Storage and Evaluation.

8.5 SAR System Validation

Per FCC KDB 865664 D02v01, SAR system verification is required to confirm measurement accuracy. The SAR systems (including SAR probes, system components and software versions) used for this device were validated against its performance specifications prior to the SAR measurements. Reference dipoles are used with the required tissue-equivalent media for system validation, according to the procedures outlined in FCC KDB 865664 D01 and IEEE 1528-2013. Since SAR probe calibrations are frequency dependent, each probe calibration point must be validated at a frequency within the valid frequency range of the probe calibration point, using the system that normally operates with the probe for routine SAR measurements and according to the required tissue-equivalent media.

a tabulated summary of the system validation status, measurement frequencies, SAR probes, calibrated signal type(s) and tissue dielectric parameters has been included.

Frequency [MHz]	Date	Probe SN	Probe Type	Probe Cal Point		PERM (Er)	COND (Σ)	CW Validation			Mod. Validation		
								Sensitivity	Probe Linearity	Probe Isotropy	Mod. Type	Duty Factor	PAR
750	6/25/2019	3677	EX3DV4	750	Head	42.81	0.85	PASS	PASS	PASS	FDD	PASS	N/A
835	6/25/2019	3677	EX3DV4	835	Head	42.22	0.90	PASS	PASS	PASS	GMSK	PASS	N/A
1750	6/25/2019	3677	EX3DV4	1750	Head	39.91	1.32	PASS	PASS	PASS	NA	N/A	N/A
1900	6/25/2019	3677	EX3DV4	1900	Head	39.43	1.42	PASS	PASS	PASS	GMSK	PASS	N/A
2450	6/25/2019	3677	EX3DV4	2450	Head	38.19	1.83	PASS	PASS	PASS	OFDM	PASS	PASS
2600	6/25/2019	3677	EX3DV4	2600	Head	37.60	1.99	PASS	PASS	PASS	TDD	PASS	N/A
5250	6/25/2019	3677	EX3DV4	5250	Head	35.36	4.83	PASS	PASS	PASS	OFDM	N/A	PASS
5600	6/25/2019	3677	EX3DV4	5600	Head	34.43	5.29	PASS	PASS	PASS	OFDM	N/A	PASS
5750	6/25/2019	3677	EX3DV4	5750	Head	34.07	5.47	PASS	PASS	PASS	OFDM	N/A	PASS
750	6/25/2019	3677	EX3DV4	750	Body	55.35	0.99	PASS	PASS	PASS	FDD	PASS	N/A
835	6/25/2019	3677	EX3DV4	835	Body	54.88	0.98	PASS	PASS	PASS	GMSK	PASS	N/A
1750	6/25/2019	3677	EX3DV4	1750	Body	51.24	1.44	PASS	PASS	PASS	NA	N/A	N/A
1900	6/25/2019	3677	EX3DV4	1900	Body	50.98	1.56	PASS	PASS	PASS	GMSK	PASS	N/A
2450	6/25/2019	3677	EX3DV4	2450	Body	50.59	1.95	PASS	PASS	PASS	OFDM	PASS	PASS
2600	6/25/2019	3677	EX3DV4	2600	Body	50.14	2.13	PASS	PASS	PASS	TDD	PASS	N/A
5250	6/25/2019	3677	EX3DV4	5250	Body	47.37	5.44	PASS	PASS	PASS	OFDM	N/A	PASS
5600	6/25/2019	3677	EX3DV4	5600	Body	46.42	5.99	PASS	PASS	PASS	OFDM	N/A	PASS
5750	6/25/2019	3677	EX3DV4	5750	Body	46.02	6.23	PASS	PASS	PASS	OFDM	N/A	PASS

NOTE: While the probes have been calibrated for both CW and modulated signals, all measurements were performed using communication systems calibrated for CW signals only. Modulations in the table above represent test configurations for which the measurement system has been validated per FCC KDB Publication 865664D01v01 for scenarios when CW probe calibrations are used with other signal types. SAR systems were validated for modulated signals with a periodic duty cycle, such as GMSK, or with a high peak to average ratio (>5dB), such as OFDM according to KDB 865664.



9 Normal and Maximum Output Power

KDB 447498 D01 at the maximum rated output power and within the tune-up tolerance range specified for the product, but not more than 2 dB lower than the maximum tune-up tolerance limit.

9.3 LTE Mode

UE Power Class: 3 (23 +/- 2dBm). The allowed Maximum Power Reduction (MPR) for the maximum output power due to higher order modulation and transmit bandwidth configuration (resource blocks) is specified in Table 6.2.3-1 of the 3GPP TS36.101.

Table 6.2.3-1: Maximum Power Reduction (MPR) for Power Class 3

Modulation	Channel bandwidth / Transmission bandwidth (N _{RB})						MPR (dB)
	1.4 MHz	3.0 MHz	5 MHz	10 MHz	15 MHz	20 MHz	
QPSK	> 5	> 4	> 8	> 12	> 16	> 18	≤ 1
16 QAM	≤ 5	≤ 4	≤ 8	≤ 12	≤ 16	≤ 18	≤ 1
16 QAM	> 5	> 4	> 8	> 12	> 16	> 18	≤ 2
64 QAM	≤ 5	≤ 4	≤ 8	≤ 12	≤ 16	≤ 18	≤ 2
64 QAM	> 5	> 4	> 8	> 12	> 16	> 18	≤ 3

LTE TDD Band 41				Conducted Power(dBm)						
Bandwidth	Modulation	RB allocation	Off set	Channel/Frequency(MHz)					Tune-up	
				39675/2498.5	40148/2545.8	40620/2593	41093/2640.3	41565/2687.5		
5MHz	QPSK	1	0	21.78	22.24	21.84	21.78	21.83	23.00	
		1	13	21.65	21.70	21.65	21.37	21.90	23.00	
		1	24	21.70	21.79	22.03	21.39	22.87	23.00	
		12	0	20.91	20.74	20.74	20.60	20.67	21.50	
		12	6	20.88	20.61	20.83	20.49	20.72	21.50	
		12	13	20.96	20.64	20.94	20.42	21.05	21.50	
	16QAM	25	0	20.92	20.66	20.81	20.49	20.89	21.50	
		1	0	21.04	21.12	21.11	20.97	20.83	21.50	
		1	13	21.02	20.67	20.92	20.61	20.91	21.50	
		1	24	20.96	20.80	21.25	20.61	21.50	21.50	
		12	0	20.20	19.67	19.90	19.76	19.66	21.50	
		12	6	20.07	19.59	19.98	19.58	19.76	21.50	
		12	13	20.12	19.56	20.14	19.61	20.10	21.50	
		25	0	20.12	19.57	19.97	19.64	19.94	21.50	
		64QAM	1	0	20.88	20.89	20.87	20.77	20.17	21.50
			1	13	20.82	20.44	20.67	20.38	20.25	21.50
			1	24	20.80	20.52	21.01	20.35	20.95	21.50
			12	0	20.19	19.61	19.88	19.71	19.26	20.50
	12		6	20.04	19.50	19.91	19.54	19.28	20.50	
	12		13	20.07	19.47	20.07	19.54	19.62	20.50	
	25	0	20.17	19.59	19.99	19.67	19.58	20.50		



10MHz	QPSK	1	0	21.80	22.25	21.87	21.79	21.86	23.00
		1	25	21.68	21.75	21.69	21.42	21.94	23.00
		1	49	21.72	21.83	22.06	21.43	22.90	23.00
		25	0	20.94	20.79	20.78	20.65	20.71	21.50
		25	13	20.91	20.66	20.87	20.54	20.76	21.50
		25	25	20.98	20.68	20.99	20.46	21.10	21.50
		50	0	20.96	20.68	20.85	20.51	20.93	21.50
	16QAM	1	0	21.06	21.15	21.13	21.00	20.85	21.50
		1	25	21.05	20.71	20.95	20.65	20.94	21.50
		1	49	20.99	20.82	21.28	20.63	21.53	21.50
		25	0	20.23	19.72	19.94	19.81	19.70	21.50
		25	13	20.09	19.63	20.01	19.62	19.79	21.50
		25	25	20.15	19.61	20.18	19.66	20.14	21.50
		50	0	20.15	19.62	20.01	19.69	19.98	21.50
	64QAM	1	0	20.90	20.88	20.89	20.76	20.19	21.50
		1	25	20.85	20.44	20.70	20.38	20.28	21.50
		1	49	20.79	20.54	21.04	20.37	20.98	21.50
		25	0	20.22	19.66	19.88	19.76	19.26	20.50
		25	13	20.06	19.54	19.94	19.58	19.31	20.50
		25	25	20.10	19.52	20.11	19.59	19.66	20.50
		50	0	20.20	19.64	20.03	19.72	19.62	20.50
Bandwidth	Modulation	RB allocation	offset	Channel/Frequency(MHz)					Tune-up
				39725/ 2503.5	40173/ 2548.3	40620/ 2593	41068/ 2637.8	41515/ 2682.5	
15MHz	QPSK	1	0	21.79	22.21	21.85	21.75	21.84	23.00
		1	38	21.66	21.74	21.66	21.41	21.91	23.00
		1	74	21.69	21.78	22.02	21.38	22.86	23.00
		36	0	20.92	20.75	20.75	20.61	20.68	21.50
		36	18	20.88	20.61	20.83	20.49	20.72	21.50
		36	39	20.95	20.65	20.95	20.43	21.06	21.50
		75	0	20.94	20.64	20.80	20.47	20.88	21.50
	16QAM	1	0	21.01	21.13	21.11	20.98	20.83	21.50
		1	38	21.03	20.68	20.93	20.62	20.92	21.50
		1	74	20.96	20.78	21.25	20.59	21.50	21.50
		36	0	20.20	19.70	19.91	19.79	19.67	21.50
		36	18	20.06	19.58	19.97	19.57	19.75	21.50
		36	39	20.13	19.57	20.15	19.62	20.11	21.50
		75	0	20.12	19.57	19.97	19.64	19.94	21.50
	64QAM	1	0	20.85	20.86	20.87	20.74	20.17	21.50
		1	38	20.83	20.41	20.68	20.35	20.26	21.50
		1	74	20.80	20.53	21.05	20.36	20.99	21.50
		36	0	20.21	19.68	19.89	19.78	19.27	20.50
		36	18	20.04	19.51	19.93	19.55	19.30	20.50



Bandwidth	Modulation	RB allocation	offset	Channel/Frequency(MHz)					Tune-up
				39750/ 2506	40185/ 2549.5	40620/ 2593	41055/ 2636.5	41490/ 2680	
20MHz	QPSK	36	39	20.08	19.48	20.08	19.55	19.63	20.50
		75	0	20.17	19.59	19.99	19.67	19.58	20.50
		1	0	21.76	22.17	21.82	21.71	21.81	23.00
		1	50	21.65	21.70	21.64	21.37	21.89	23.00
		1	99	21.67	21.77	21.99	21.37	22.83	23.00
		50	0	20.89	20.70	20.71	20.56	20.64	21.50
		50	25	20.86	20.57	20.80	20.45	20.69	21.50
	50	50	20.92	20.60	20.91	20.38	21.02	21.50	
	100	0	20.91	20.59	20.76	20.42	20.84	21.50	
	16QAM	1	0	21.02	21.09	21.06	20.94	20.78	21.50
		1	50	20.99	20.66	20.89	20.60	20.88	21.50
		1	99	20.94	20.75	21.23	20.56	21.48	21.50
		50	0	20.17	19.66	19.88	19.75	19.64	21.50
		50	25	20.03	19.56	19.94	19.55	19.72	21.50
		50	50	20.10	19.52	20.11	19.57	20.07	21.50
		100	0	20.10	19.53	19.94	19.60	19.91	21.50
	64QAM	1	0	20.83	20.82	20.82	20.70	20.12	21.50
		1	50	20.79	20.39	20.64	20.33	20.22	21.50
		1	99	20.74	20.47	20.99	20.30	20.93	21.50
		50	0	20.16	19.60	19.82	19.70	19.20	20.50
		50	25	20.00	19.47	19.87	19.51	19.24	20.50
		50	50	20.05	19.43	20.04	19.50	19.59	20.50
		100	0	20.15	19.55	19.96	19.63	19.55	20.50

LTE TDD Band 43				Conducted Power(dBm)			
Bandwidth	Modulation	RB allocation	offset	Channel/Frequency(MHz)			Tune-up
				43615/ 3602.5	44590/ 3700	45565/ 3797.5	
5MHz	QPSK	1	0	20.20	20.79	20.17	21.50
		1	13	20.04	19.73	20.01	21.50
		1	24	20.46	19.92	20.86	21.50
		12	0	18.94	19.09	18.81	20.00
		12	6	18.89	18.65	19.03	20.00
		12	13	19.05	18.63	19.00	20.00
		25	0	18.96	18.92	19.16	20.00
	16QAM	1	0	19.10	19.79	19.27	20.00
		1	13	19.08	18.76	19.23	20.00
		1	24	19.61	19.09	19.65	20.00
		12	0	17.85	18.02	17.67	19.00
		12	6	17.38	17.50	17.92	19.00



Bandwidth	Modulation	RB allocation	offset	Channel/Frequency(MHz)			Tune-up
				43640/ 3605	44590/ 3700	45540/ 3795	
	64QAM	12	13	17.95	17.54	18.19	19.00
		25	0	17.90	17.76	18.02	19.00
		1	0	17.92	18.55	17.86	19.00
		1	13	17.18	17.41	17.92	19.00
		1	24	18.24	17.76	18.59	19.00
		12	0	16.27	16.86	16.77	18.00
		12	6	16.27	16.45	16.96	18.00
		12	13	16.41	16.49	17.22	18.00
		25	0	16.37	16.72	17.06	18.00
10MHz	QPSK	1	0	20.22	20.80	20.20	21.50
		1	25	20.07	19.78	20.05	21.50
		1	49	20.48	19.96	20.89	21.50
		25	0	18.97	19.14	18.85	20.00
		25	13	18.92	18.70	19.07	20.00
		25	25	19.07	18.67	19.05	20.00
		50	0	19.00	18.94	19.20	20.00
	16QAM	1	0	19.12	19.82	19.29	20.00
		1	25	19.11	18.80	19.26	20.00
		1	49	19.64	19.11	19.68	20.00
		25	0	17.88	18.07	17.71	19.00
		25	13	17.40	17.54	17.95	19.00
		25	25	17.98	17.59	18.23	19.00
		50	0	17.93	17.81	18.06	19.00
	64QAM	1	0	17.94	18.54	17.88	19.00
		1	25	17.21	17.41	17.95	19.00
		1	49	18.23	17.78	18.62	19.00
		25	0	16.30	16.91	16.77	18.00
		25	13	16.29	16.49	16.99	18.00
		25	25	16.44	16.54	17.26	18.00
		50	0	16.40	16.77	17.10	18.00
Bandwidth	Modulation	RB allocation	offset	Channel/Frequency(MHz)			Tune-up
				43665/ 3607.5	44590/ 3700	45515/ 3792.5	
15MHz	QPSK	1	0	20.21	20.76	20.18	21.50
		1	38	20.05	19.77	20.02	21.50
		1	74	20.45	19.91	20.85	21.50
		36	0	18.95	19.10	18.82	20.00
		36	18	18.89	18.65	19.03	20.00
		36	39	19.04	18.64	19.01	20.00
		75	0	18.98	18.90	19.15	20.00



	16QAM	1	0	19.07	19.80	19.27	20.00
		1	38	19.09	18.77	19.24	20.00
		1	74	19.61	19.07	19.65	20.00
		36	0	17.85	18.05	17.68	19.00
		36	18	17.37	17.49	17.91	19.00
		36	39	17.96	17.55	18.20	19.00
		75	0	17.90	17.76	18.02	19.00
	64QAM	1	0	17.89	18.52	17.86	19.00
		1	38	17.19	17.38	17.93	19.00
		1	74	18.24	17.77	18.63	19.00
		36	0	16.29	16.93	16.78	18.00
		36	18	16.27	16.46	16.98	18.00
		36	39	16.42	16.50	17.23	18.00
		75	0	16.37	16.72	17.06	18.00
Bandwidth	Modulation	RB allocation	offset	Channel/Frequency(MHz)			Tune-up
				43690/ 3610	44590/ 3700	45490/ 3790	
20MHz	QPSK	1	0	20.18	20.72	20.15	21.50
		1	50	20.04	19.73	20.00	21.50
		1	99	20.43	19.90	20.82	21.50
		50	0	18.92	19.05	18.78	20.00
		50	25	18.87	18.61	19.00	20.00
		50	50	19.01	18.59	18.97	20.00
		100	0	18.95	18.85	19.11	20.00
	16QAM	1	0	19.31	19.76	19.22	20.00
		1	50	19.05	18.75	19.20	20.00
		1	99	19.59	19.04	19.63	20.00
		50	0	17.82	18.01	17.65	19.00
		50	25	17.34	17.47	17.88	19.00
		50	50	17.93	17.50	18.16	19.00
		100	0	17.88	17.72	17.99	19.00
	64QAM	1	0	17.87	18.48	17.81	19.00
		1	50	17.15	17.36	17.89	19.00
		1	99	18.18	17.71	18.57	19.00
		50	0	16.24	16.85	16.71	18.00
		50	25	16.23	16.42	16.92	18.00
		50	50	16.39	16.45	17.19	18.00
		100	0	16.35	16.68	17.03	18.00

LTE TDD Band 48				Conducted Power(dBm)			
Bandwidth	Modulation	RB allocation	offset	Channel/Frequency(MHz)			Tune-up
				56265/ 3652.5	56490/ 3675	56715/ 3697.5	



5MHz	QPSK	1	0	21.25	21.35	21.21	22.00
		1	13	20.85	21.31	20.24	22.00
		1	24	21.45	20.98	20.40	22.00
		12	0	19.54	19.84	19.39	20.50
		12	6	19.73	19.79	18.98	20.50
		12	13	19.79	19.62	18.81	20.50
		25	0	19.63	19.72	19.11	20.50
	16QAM	1	0	19.76	20.61	20.55	21.00
		1	13	19.74	20.10	19.39	21.00
		1	24	20.32	20.25	19.72	21.00
		12	0	18.42	18.75	18.28	19.50
		12	6	18.59	18.65	17.96	19.50
		12	13	18.64	18.56	17.81	19.50
		25	0	18.70	18.70	18.05	19.50
	64QAM	1	0	17.95	18.55	17.89	19.00
		1	13	17.21	17.39	17.95	19.00
		1	24	18.23	17.78	18.63	19.00
		12	0	16.29	16.90	16.76	18.00
		12	6	16.30	16.50	17.00	18.00
		12	13	16.44	16.54	17.26	18.00
		25	0	16.39	16.76	17.11	18.00
Bandwidth	Modulation	RB allocation	offset	Channel/Frequency(MHz)			Tune-up
				56290/3655	56490/3675	56690/3695	
10MHz	QPSK	1	0	21.27	21.36	21.24	22.00
		1	25	20.88	21.36	20.28	22.00
		1	49	21.47	21.02	20.43	22.00
		25	0	19.57	19.89	19.43	20.50
		25	13	19.76	19.84	19.02	20.50
		25	25	19.81	19.66	18.86	20.50
		50	0	19.67	19.74	19.15	20.50
	16QAM	1	0	19.78	20.64	20.57	21.00
		1	25	19.77	20.14	19.42	21.00
		1	49	20.35	20.27	19.75	21.00
		25	0	18.45	18.80	18.32	19.50
		25	13	18.61	18.69	17.99	19.50
		25	25	18.67	18.61	17.85	19.50
		50	0	18.73	18.75	18.09	19.50
	64QAM	1	0	17.92	18.55	17.86	19.00
		1	25	17.18	17.41	17.92	19.00
		1	49	18.24	17.76	18.59	19.00
		25	0	16.27	16.86	16.77	18.00
		25	13	16.27	16.45	16.96	18.00



Bandwidth	Modulation	RB allocation	offset	Channel/Frequency(MHz)			Tune-up
				56315/ 36.57.5	56490/ 3675	56665/ 3692.5	
		25	25	16.41	16.49	17.22	18.00
		50	0	16.37	16.72	17.06	18.00
Bandwidth	Modulation	RB allocation	offset	Channel/Frequency(MHz)			Tune-up
				56315/ 36.57.5	56490/ 3675	56665/ 3692.5	
15MHz	QPSK	1	0	21.26	21.32	21.22	22.00
		1	38	20.86	21.35	20.25	22.00
		1	74	21.44	20.97	20.39	22.00
		36	0	19.55	19.85	19.40	20.50
		36	18	19.73	19.79	18.98	20.50
		36	39	19.78	19.63	18.82	20.50
		75	0	19.65	19.70	19.10	20.50
	16QAM	1	0	19.73	20.62	20.55	21.00
		1	38	19.75	20.11	19.40	21.00
		1	74	20.32	20.23	19.72	21.00
		36	0	18.42	18.78	18.29	19.50
		36	18	18.58	18.64	17.95	19.50
		36	39	18.65	18.57	17.82	19.50
		75	0	18.70	18.70	18.05	19.50
	64QAM	1	0	17.94	18.54	17.88	19.00
		1	38	17.21	17.41	17.95	19.00
		1	74	18.23	17.78	18.62	19.00
		36	0	16.30	16.91	16.77	18.00
		36	18	16.29	16.49	16.99	18.00
		36	39	16.44	16.54	17.26	18.00
		75	0	16.40	16.77	17.10	18.00
Bandwidth	Modulation	RB allocation	offset	Channel/Frequency(MHz)			Tune-up
				56340/ 3660	56490/ 3675	56640/ 3690	
20MHz	QPSK	1	0	21.23	21.28	21.19	22.00
		1	50	20.85	21.31	20.23	22.00
		1	99	21.42	20.96	20.36	22.00
		50	0	19.52	19.80	19.36	20.50
		50	25	19.71	19.75	18.95	20.50
		50	50	19.75	19.58	18.78	20.50
		100	0	19.62	19.65	19.06	20.50
	16QAM	1	0	20.03	20.58	20.50	21.00
		1	50	19.71	20.09	19.36	21.00
		1	99	20.30	20.20	19.70	21.00
		50	0	18.39	18.74	18.26	19.50
		50	25	18.55	18.62	17.92	19.50
		50	50	18.62	18.52	17.78	19.50
		100	0	18.68	18.66	18.02	19.50



	64QAM	1	0	17.89	18.52	17.86	19.00
		1	50	17.19	17.38	17.93	19.00
		1	99	18.24	17.77	18.63	19.00
		50	0	16.29	16.93	16.78	18.00
		50	25	16.27	16.46	16.98	18.00
		50	50	16.42	16.50	17.23	18.00
		100	0	16.37	16.72	17.06	18.00

LTE TDD Band 53				Conducted Power(dBm)			
Bandwidth	Modulation	RB allocation	offset	Channel/Frequency(MHz)			Tune-up
				60147/ 2484.2	60197/ 2489.2	60248/ 2494.3	
1.4MHz	QPSK	1	0	20.97	21.12	21.07	22.00
		1	2	21.05	20.90	20.86	22.00
		1	5	21.20	21.23	21.20	22.00
		3	0	20.67	20.71	20.63	22.00
		3	2	20.84	20.92	20.73	22.00
		3	3	20.75	20.76	20.88	22.00
		6	0	19.76	19.82	19.78	20.50
	16QAM	1	0	20.42	20.30	20.25	21.00
		1	2	20.40	20.30	20.24	21.00
		1	5	20.37	20.41	20.36	21.00
		3	0	19.81	19.82	19.77	21.00
		3	2	19.93	19.92	19.91	21.00
		3	3	19.89	19.93	19.86	21.00
		6	0	18.96	18.98	18.96	19.50
	64QAM	1	0	17.97	18.60	17.91	19.00
		1	2	17.21	17.44	17.96	19.00
		1	5	18.27	17.84	18.62	19.00
		3	0	17.21	17.78	17.70	18.00
		3	2	17.23	17.40	17.65	18.00
		3	3	17.36	17.46	17.56	18.00
		6	0	16.38	16.76	17.11	18.00
Bandwidth	Modulation	RB allocation	offset	Channel/Frequency(MHz)			Tune-up
				60155/ 2485	60197/ 2489.2	60240/ 2493.5	
3MHz	QPSK	1	0	20.99	21.16	21.10	22.00
		1	7	21.03	20.93	20.90	22.00
		1	14	21.23	21.28	21.24	22.00
		8	0	19.77	19.83	19.76	20.50
		8	4	19.96	20.02	19.85	20.50
		8	7	19.85	19.87	19.98	20.50
		15	0	19.76	19.86	19.81	20.50



Bandwidth	Modulation	RB allocation	offset	Channel/Frequency(MHz)			Tune-up
				60165/ 2486	60197/ 2489.2	60230/ 2492.5	
	16QAM	1	0	20.45	20.32	20.28	21.00
		1	7	20.43	20.30	20.28	21.00
		1	14	20.39	20.45	20.39	21.00
		8	0	18.92	18.95	18.89	19.50
		8	4	19.04	19.05	19.03	19.50
		8	7	18.99	19.05	18.99	19.50
		15	0	18.99	19.02	18.99	19.50
	64QAM	1	0	17.99	18.61	17.93	19.00
		1	7	17.24	17.46	17.98	19.00
		1	14	18.29	17.83	18.64	19.00
		8	0	16.33	16.92	16.83	18.00
		8	4	16.33	16.52	17.03	18.00
		8	7	16.46	16.58	17.29	18.00
		15	0	16.42	16.81	17.13	18.00
5MHz	QPSK	1	0	20.96	21.14	21.06	22.00
		1	13	21.01	20.89	20.87	22.00
		1	24	21.20	21.23	21.20	22.00
		12	0	19.74	19.78	19.72	20.50
		12	6	19.94	19.98	19.80	20.50
		12	13	19.83	19.85	19.94	20.50
		25	0	19.76	19.85	19.79	20.50
	16QAM	1	0	20.42	20.28	20.25	21.00
		1	13	20.40	20.28	20.25	21.00
		1	24	20.36	20.43	20.35	21.00
		12	0	18.90	18.91	18.86	19.50
		12	6	19.01	19.00	18.99	19.50
		12	13	18.96	19.00	18.95	19.50
		25	0	18.97	18.98	18.94	19.50
	64QAM	1	0	17.97	18.62	17.91	19.00
		1	13	17.21	17.46	17.95	19.00
		1	24	18.30	17.81	18.61	19.00
		12	0	16.30	16.87	16.83	18.00
		12	6	16.31	16.48	17.00	18.00
		12	13	16.43	16.53	17.25	18.00
		25	0	16.39	16.76	17.09	18.00
Bandwidth	Modulation	RB allocation	offset	Channel/Frequency(MHz)			Tune-up
				60190/ 2488.5	60197/ 2489.2	60205/ 2490	
10MHz	QPSK	1	0	20.94	21.07	21.04	22.00
		1	25	21.01	20.89	20.86	22.00



		1	49	21.17	21.21	21.16	22.00
		25	0	19.72	19.74	19.69	20.50
		25	13	19.92	19.94	19.77	20.50
		25	25	19.79	19.81	19.91	20.50
		50	0	19.75	19.78	19.74	20.50
	16QAM	1	0	20.10	20.25	20.20	21.00
		1	25	20.37	20.27	20.22	21.00
		1	49	20.34	20.38	20.33	21.00
		25	0	18.87	18.90	18.84	19.50
		25	13	18.97	18.97	18.95	19.50
		25	25	18.94	18.96	18.92	19.50
		50	0	18.95	18.94	18.91	19.50
	64QAM	1	0	18.49	18.51	18.43	19.00
		1	25	17.74	17.96	18.48	19.00
		1	49	18.79	18.33	18.56	19.00
		25	0	16.83	17.42	17.33	18.00
		25	13	16.83	17.02	17.53	18.00
		25	25	16.96	17.08	17.79	18.00
		50	0	16.92	17.31	17.63	18.00

10 Measured and Reported (Scaled) SAR Results

10.3 EUT Antenna Locations

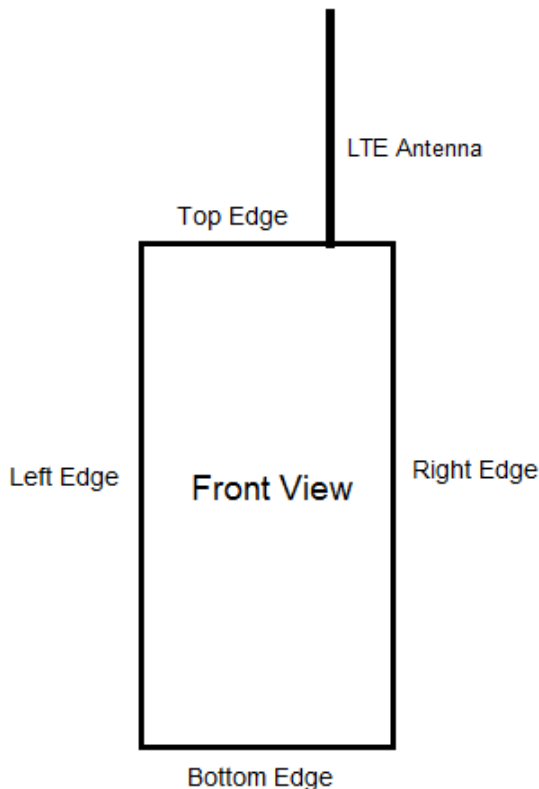

Overall (Length x Width): 149mm x 66mm						
Overall Diagonal: 157mm/Antenna Length: 105mm						
Distance of the Antenna to the EUT surface/edge						
Antenna	Back Side	Front side	Left Edge	Right Edge	Top Edge	Bottom Edge
LTE Antenna	<25mm	<25mm	>25mm	<25mm	<25mm	>25mm
Body mode, Positions for SAR tests						
Mode	Back Side	Front side	Left Edge	Right Edge	Top Edge	Bottom Edge
LTE Antenna	Yes	Yes	N/A	Yes	Yes	N/A

Note: 1. Per KDB 941225 D06, when the overall device length and width are $\geq 9\text{cm} \times 5\text{cm}$, the test distance is 10mm. SAR must be measured for all sides and surfaces with a transmitting antenna located within 25mm from that surface or edge.

2. Per FCC KDB 447498 D01,

for each exposure position, testing of other required channels within the operating mode of a frequency band is not required when the reported 1-g or 10-g SAR for the mid-band or highest output power channel is:

- a) $\leq 0.8\text{ W/kg}$ or 2.0 W/kg , for 1-g or 10-g respectively, when the transmission band is $\leq 100\text{MHz}$
- b) $\leq 0.6\text{ W/kg}$ or 1.5 W/kg , for 1-g or 10-g respectively, when the transmission band is between 100 MHz and 200 MHz.
- c) $\leq 0.4\text{ W/kg}$ or 1.0 W/kg , for 1-g or 10-g respectively, when the transmission band is $\geq 200\text{ MHz}$.

3. When the original highest measured SAR is $\geq 0.80\text{ W/kg}$, the measurement was repeated once.



10.4 Measured SAR Results

Table 4: LTE Band 41

Test Position	Scenario	Distance (mm)	Duty Cycle	RB allocation	RB offset	Channel/Frequency (MHz)	Tune-up (dBm)	Measured power (dBm)	Limit of SAR 1.6 W/kg (mW/g)				Plot No.
									Measured SAR1g	Power Drift (dB)	Scaling Factor	Report SAR1g	
0mmBody SAR/ 10mmFace to mouth													
Back Side	body	0	1:1.58	1	99	41490/2680	23.00	22.83	0.510	0.038	1.04	0.530	/
Front Side	body	0	1:1.58	1	99	41490/2680	23.00	22.83	0.796	-0.067	1.04	0.828	/
Left Edge	body	0	1:1.58	1	99	41490/2680	23.00	22.83	0.337	0.180	1.04	0.350	/
Right Edge	body	0	1:1.58	1	0	40185/2549.5	23.00	22.17	1.090	-0.046	1.21	1.320	4
	body	0	1:1.58	1	99	40620/2593	23.00	21.99	0.794	-0.027	1.26	1.002	/
	body	0	1:1.58	1	99	41490/2680	23.00	22.83	0.769	-0.022	1.04	0.800	/
Top Edge	body	0	1:1.58	1	99	41490/2680	23.00	22.83	0.008	-0.042	1.04	0.009	/
Bottom Edge	N/A	N/A	N/A	N/A	N/A	N/A	N/A	N/A	N/A	N/A	N/A	N/A	N/A
Back Side	body	0	1:1.58	50%	50	41490/2680	21.50	21.02	0.465	-0.070	1.12	0.519	/
Front Side	body	0	1:1.58	50%	50	41490/2680	21.50	21.02	0.653	0.020	1.12	0.729	/
Left Edge	body	0	1:1.58	50%	50	41490/2680	21.50	21.02	0.249	0.111	1.12	0.278	/
Right Edge	body	0	1:1.58	50%	50	39750/2506	21.50	20.92	0.779	-0.010	1.14	0.890	/
	body	0	1:1.58	50%	50	40620/2593	21.50	20.91	0.596	-0.180	1.15	0.683	/
	body	0	1:1.58	50%	50	41490/2680	21.50	21.02	0.564	-0.150	1.12	0.630	/
Top Edge	body	0	1:1.58	50%	50	41490/2680	21.50	21.02	0.005	0.086	1.12	0.006	/
Bottom Edge	N/A	N/A	N/A	N/A	N/A	N/A	N/A	N/A	N/A	N/A	N/A	N/A	N/A
Right Edge	body	0	1:1.58	100%	0	39750/2506	21.50	20.91	0.893	-0.014	1.15	1.023	/
Right Edge Repeated	body	0	1:1.58	1	0	40185/2549.5	23.00	22.17	1.012	-0.060	1.21	1.225	/
Front Side	face up	10	1:1.58	1	99	41490/2680	23.00	22.83	0.454	-0.024	1.04	0.472	/
Front Side	face up	10	1:1.58	50%	50	41490/2680	21.50	21.02	0.348	-0.080	1.12	0.389	/

Note: 1. The value with blue color is the maximum SAR Value of each test band.

2. For QPSK with 100% RB allocation, SAR is required when and the highest reported SAR for 1 RB and 50% RB allocation in are \geq 50% limit(1g).

Measurement Variability

Test Position	Channel/ Frequency(MHz)	MAX Measured SAR _{1g} (W/kg)	1 st Repeated SAR _{1g} (W/kg)	Ratio
Right Edge	40185/2549.5	1.090	1.012	1.08

Note: 1) A second repeated measurement was performed only if the ratio of largest to smallest SAR for the original and first repeated measurements was > 1.20 or when the original or repeated measurement was \geq 1.45 W/kg (~ 10% from the 1-g SAR limit).

2) A third repeated measurement was performed only if the original, first or second repeated measurement was \geq 1.5 W/kg and the ratio of largest to smallest SAR for the original, first and second repeated measurements is > 1.20.



Table 5: LTE Band 43

Test Position	Scenario	Distance (mm)	Duty Cycle	RB allocation	RB offset	Channel/Frequency (MHz)	Tune-up (dBm)	Measured power (dBm)	Limit of SAR 1.6 W/kg (mW/g)				Plot No.
									Measured SAR1g	Power Drift (dB)	Scaling Factor	Report SAR1g	
0mmBody SAR/ 10mmFace to mouth													
Back Side	body	0	1:1.58	1	99	45490/3790	21.50	20.82	0.612	-0.160	1.17	0.716	/
Front Side	body	0	1:1.58	1	99	45490/3790	21.50	20.82	0.382	0.030	1.17	0.447	/
Left Edge	body	0	1:1.58	1	99	45490/3790	21.50	20.82	0.082	0.045	1.17	0.096	/
Right Edge	body	0	1:1.58	1	99	43690/3610	21.50	20.43	0.428	-0.029	1.28	0.548	/
	body	0	1:1.58	1	0	44590/3700	21.50	20.72	0.724	0.031	1.20	0.866	/
	body	0	1:1.58	1	99	45490/3790	21.50	20.82	0.933	0.120	1.17	1.091	5
Top Edge	body	0	1:1.58	1	99	45490/3790	21.50	20.82	0.012	0.099	1.17	0.014	/
Bottom Edge	N/A	N/A	N/A	N/A	N/A	N/A	N/A	N/A	N/A	N/A	N/A	N/A	N/A
Back Side	body	0	1:1.58	50%	0	44590/3700	20.00	19.05	0.317	-0.050	1.24	0.395	/
Front Side	body	0	1:1.58	50%	0	44590/3700	20.00	19.05	0.115	0.010	1.24	0.143	/
Left Edge	body	0	1:1.58	50%	0	44590/3700	20.00	19.05	0.022	0.044	1.24	0.027	/
Right Edge	body	0	1:1.58	50%	25	45490/3790	20.00	19.00	0.607	-0.050	1.26	0.764	/
Top Edge	body	0	1:1.58	50%	0	44590/3700	20.00	19.05	0.005	0.000	1.24	0.006	/
Bottom Edge	N/A	N/A	N/A	N/A	N/A	N/A	N/A	N/A	N/A	N/A	N/A	N/A	N/A
Right Edge	body	0	1:1.58	100%	0	45490/3790	20.00	19.11	0.598	0.022	1.23	0.734	/
Right Edge Repeated	body	0	1:1.58	1	99	45490/3790	21.50	20.82	0.915	0.020	1.17	1.070	/
Front Side	face up	10	1:1.58	1	99	45490/3790	21.50	20.82	0.195	0.041	1.17	0.228	/
Front Side	face up	10	1:1.58	50%	0	44590/3700	20.00	19.05	0.032	0.050	1.24	0.040	/

Note: 1. The value with blue color is the maximum SAR Value of each test band.
 2. For QPSK with 100% RB allocation, SAR is required when and the highest reported SAR for 1 RB and 50% RB allocation in are $\geq 50\%$ limit(1g).

Measurement Variability				
Test Position	Channel/ Frequency(MHz)	MAX Measured SAR _{1g} (W/kg)	1 st Repeated SAR _{1g} (W/kg)	Ratio
Right Edge	45490/3790	0.933	0.915	1.02

Note: 1) A second repeated measurement was performed only if the ratio of largest to smallest SAR for the original and first repeated measurements was > 1.20 or when the original or repeated measurement was ≥ 1.45 W/kg (~ 10% from the 1-g SAR limit).
 2) A third repeated measurement was performed only if the original, first or second repeated measurement was ≥ 1.5 W/kg and the ratio of largest to smallest SAR for the original, first and second repeated measurements is > 1.20 .



Table 6: LTE Band 48

Test Position	Scenario	Distance (mm)	Duty Cycle	RB allocation	RB offset	Channel/Frequency (MHz)	Tune-up (dBm)	Measured power (dBm)	Limit of SAR 1.6 W/kg (mW/g)				Plot No.
									Measured SAR1g	Power Drift (dB)	Scaling Factor	Report SAR1g	
0mmBody SAR/ 10mmFace to mouth													
Back Side	body	0	1:1.58	1	99	56340/3660	22.00	21.42	0.156	-0.061	1.14	0.178	/
Front Side	body	0	1:1.58	1	99	56340/3660	22.00	21.42	0.120	0.030	1.14	0.137	/
Left Edge	body	0	1:1.58	1	99	56340/3660	22.00	21.42	0.022	0.090	1.14	0.025	/
Right Edge	body	0	1:1.58	1	50	56490/3675	22.00	21.31	0.304	-0.033	1.17	0.356	6
Top Edge	body	0	1:1.58	1	99	56340/3660	22.00	21.42	0.003	0.000	1.14	0.003	/
Bottom Edge	N/A	N/A	N/A	N/A	N/A	N/A	N/A	N/A	N/A	N/A	N/A	N/A	N/A
Back Side	body	0	1:1.58	50%	0	56490/3675	20.50	19.80	0.106	0.070	1.17	0.125	/
Front Side	body	0	1:1.58	50%	0	56490/3675	20.50	19.80	0.105	0.010	1.17	0.123	/
Left Edge	body	0	1:1.58	50%	0	56490/3675	20.50	19.80	0.043	0.114	1.17	0.050	/
Right Edge	body	0	1:1.58	50%	0	56490/3675	20.50	19.80	0.208	0.000	1.17	0.244	/
Top Edge	body	0	1:1.58	50%	0	56490/3675	20.50	19.80	0.000	0.000	1.17	0.000	/
Bottom Edge	N/A	N/A	N/A	N/A	N/A	N/A	N/A	N/A	N/A	N/A	N/A	N/A	N/A
Front Side	face up	10	1:1.58	1	99	56340/3660	22.00	21.42	0.090	0.037	1.14	0.103	/
Front Side	face up	10	1:1.58	50%	0	56490/3675	20.50	19.80	0.092	0.150	1.17	0.108	/

Note: 1. The value with blue color is the maximum SAR Value of each test band.

2. For QPSK with 100% RB allocation, SAR is required when and the highest reported SAR for 1 RB and 50% RB allocation in are \geq 50% limit(1g).



Table 7: LTE Band 53

Test Position	Scenario	Distance (mm)	Duty Cycle	RB allocation	RB offset	Channel/Frequency (MHz)	Tune-up (dBm)	Measured power (dBm)	Limit of SAR 1.6 W/kg (mW/g)				Plot No.
									Measured SAR1g	Power Drift (dB)	Scaling Factor	Report SAR1g	
0mmBody SAR/ 10mmFace to mouth													
Back Side	body	0	1:1.58	1	49	60197/2489.2	22.00	21.21	0.629	-0.027	1.20	0.754	/
Front Side	body	0	1:1.58	1	49	60197/2489.2	22.00	21.21	0.735	-0.020	1.20	0.882	/
Left Edge	body	0	1:1.58	1	49	60197/2489.2	22.00	21.21	0.169	0.080	1.20	0.203	/
Right Edge	body	0	1:1.58	1	49	60190/2488.5	22.00	21.17	0.767	-0.020	1.21	0.929	/
	body	0	1:1.58	1	49	60197/2489.2	22.00	21.21	0.773	-0.020	1.20	0.927	/
	body	0	1:1.58	1	49	60205/2490	22.00	21.16	0.768	-0.160	1.21	0.932	7
Top Edge	body	0	1:1.58	1	49	60197/2489.2	22.00	21.21	0.011	-0.033	1.20	0.013	/
Bottom Edge	N/A	N/A	N/A	N/A	N/A	N/A	N/A	N/A	N/A	N/A	N/A	N/A	N/A
Back Side	body	0	1:1.58	50%	13	60197/2489.2	20.50	19.94	0.471	0.070	1.14	0.536	/
Front Side	body	0	1:1.58	50%	13	60197/2489.2	20.50	19.94	0.683	0.060	1.14	0.777	/
Left Edge	body	0	1:1.58	50%	13	60197/2489.2	20.50	19.94	0.131	0.029	1.14	0.149	/
Right Edge	body	0	1:1.58	50%	13	60197/2489.2	20.50	19.94	0.596	-0.080	1.14	0.678	/
Top Edge	body	0	1:1.58	50%	13	60197/2489.2	20.50	19.94	0.007	0.100	1.14	0.008	/
Bottom Edge	N/A	N/A	N/A	N/A	N/A	N/A	N/A	N/A	N/A	N/A	N/A	N/A	N/A
Right Edge	body	0	1:1.58	100%	0	60197/2489.2	20.50	19.78	0.582	0.011	1.18	0.687	/
Right Edge Repeated	body	0	1:1.58	1	49	60205/2490	22.00	21.16	0.752	-0.042	1.21	0.912	/
Front Side	face up	10	1:1.58	1	49	60197/2489.2	22.00	21.21	0.449	-0.080	1.20	0.539	/
Front Side	face up	10	1:1.58	50%	13	60197/2489.2	20.50	19.94	0.354	0.140	1.14	0.403	/

Note: 1. The value with blue color is the maximum SAR Value of each test band.

2. For QPSK with 100% RB allocation, SAR is required when and the highest reported SAR for 1 RB and 50% RB allocation in are \geq 50% limit(1g).



11 Measurement Uncertainty

Per KDB 865664 D01 SAR Measurement 100 MHz to 6 GHz, when the highest measured 1-g SAR within a frequency band is < 1.5 W/kg, the extensive SAR measurement uncertainty analysis described in IEEE Std 1528- 2013 is not required in SAR reports submitted for equipment approval.

ANNEX A: Test Layout



Tissue Simulating Liquids

For the measurement of the field distribution inside the flat phantom with DASY, the phantom must be filled with around 25 liters of homogeneous body tissue simulating liquid. For Head and Body SAR testing, the liquid height from the center of the flat phantom to the liquid top surface is larger than 15 cm, which is shown in Picture 3.

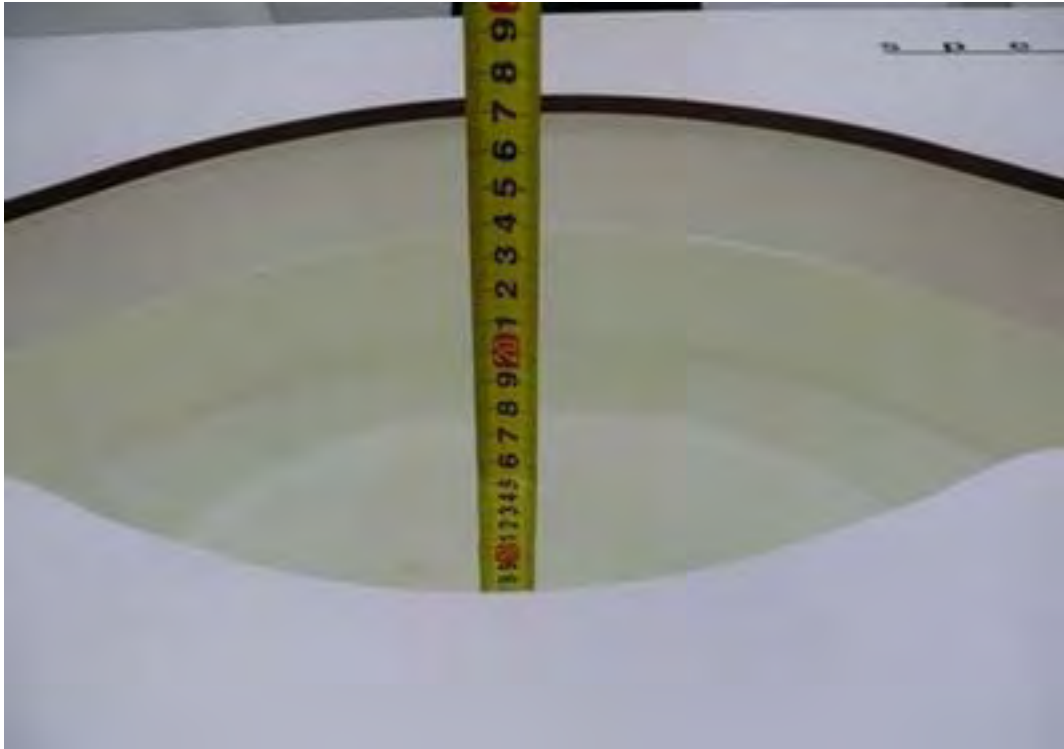

Picture 3: Liquid depth in the flat Phantom

ANNEX B: System Check Results

Plot 1 System Performance Check at 2450 MHz TSL

DUT: Dipole 2450 MHz; Type: D2450V2; Serial: D2450V2

Date: 3/20/2020

Communication System: CW; Frequency: 2450 MHz; Duty Cycle: 1:1

Medium parameters used: $f = 2450$ MHz; $\sigma = 1.81$ S/m; $\epsilon_r = 38.6$; $\rho = 1000$ kg/m³

Ambient Temperature: 22.3 °C Liquid Temperature: 21.5 °C

Phantom section: Flat Section

DASY5 Configuration:

Sensor-Surface: 1.4mm (Mechanical Surface Detection)

Probe: EX3DV4 - SN3677; ConvF(7.50, 7.50, 7.50); Calibrated: 6/19/2019;

Electronics: DAE4 SN1317; Calibrated: 10/23/2019

Phantom: SAM1; Type: SAM; Serial: TP-1534

Measurement SW: DASY52, Version 52.10 (1); SEMCAD X Version 14.6.11 (7439)

d=10mm, Pin=250mW/Area Scan (41x71x1): Measurement grid: dx=12mm, dy=12mm

Maximum value of SAR (measured) = 18.2 mW/g

d=10mm, Pin=250mW/Zoom Scan (7x7x7)/Cube 0: Measurement grid: dx=5mm, dy=5mm,

dz=5mm

Reference Value = 88.8 V/m; Power Drift = 0.075 dB

Peak SAR (extrapolated) = 30 W/kg

SAR(1 g) = 13.7 mW/g; SAR(10 g) = 6.22 mW/g

Maximum value of SAR (measured) = 15.9 mW/g

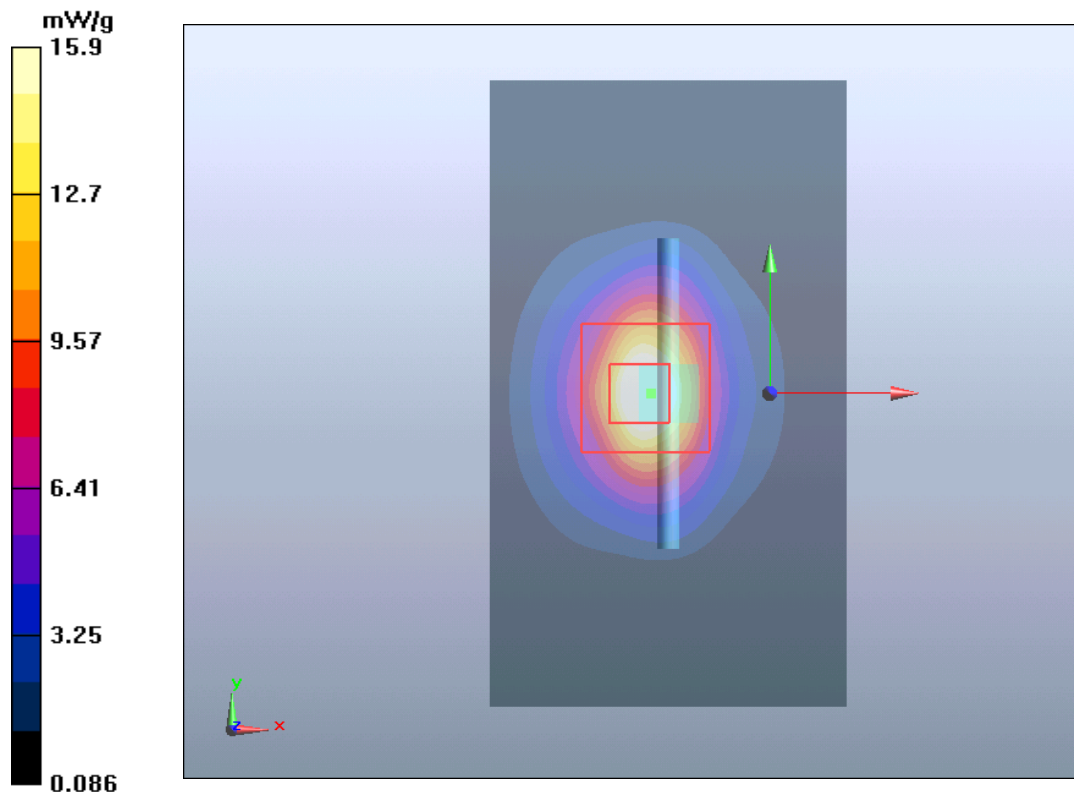

Plot 2 System Performance Check at 2600 MHz TSL

DUT: Dipole 2600 MHz; Type: D2600V2; Serial: D2600V2

Date: 3/21/2020

Communication System: CW; Frequency: 2600 MHz

Medium parameters used: $f = 2600$ MHz; $\sigma = 2.01$ S/m; $\epsilon_r = 38.2$; $\rho = 1000$ kg/m³

Phantom section: Flat Section

DASY5 Configuration:

Sensor-Surface: 1.4mm (Mechanical Surface Detection)

Probe: EX3DV4 - SN3677; ConvF(7.20, 7.20, 7.20); Calibrated: 6/19/2019;

Electronics: DAE4 SN1317; Calibrated: 10/23/2019

Phantom: SAM1; Type: SAM; Serial: TP-1534

Measurement SW: DASY52, Version 52.10 (1); SEMCAD X Version 14.6.11 (7439)

d=10mm, Pin=250mW/Area Scan (4x7x1): Measurement grid:dx=12mm, dy=12mm

Maximum value of SAR (measured) = 17.439 mW/g

d=10mm, Pin=250mW/Zoom Scan (7x7x7)/Cube 0: Measurement grid: dx=5mm, dy=5mm, dz=5mm

Reference Value = 87.998 V/m; Power Drift = -0.04 dB

Peak SAR (extrapolated) = 31.858 W/kg

SAR(1 g) = 13.9 mW/g; SAR(10 g) = 6.07 mW/g

Maximum value of SAR (measured) = 15.617 mW/g

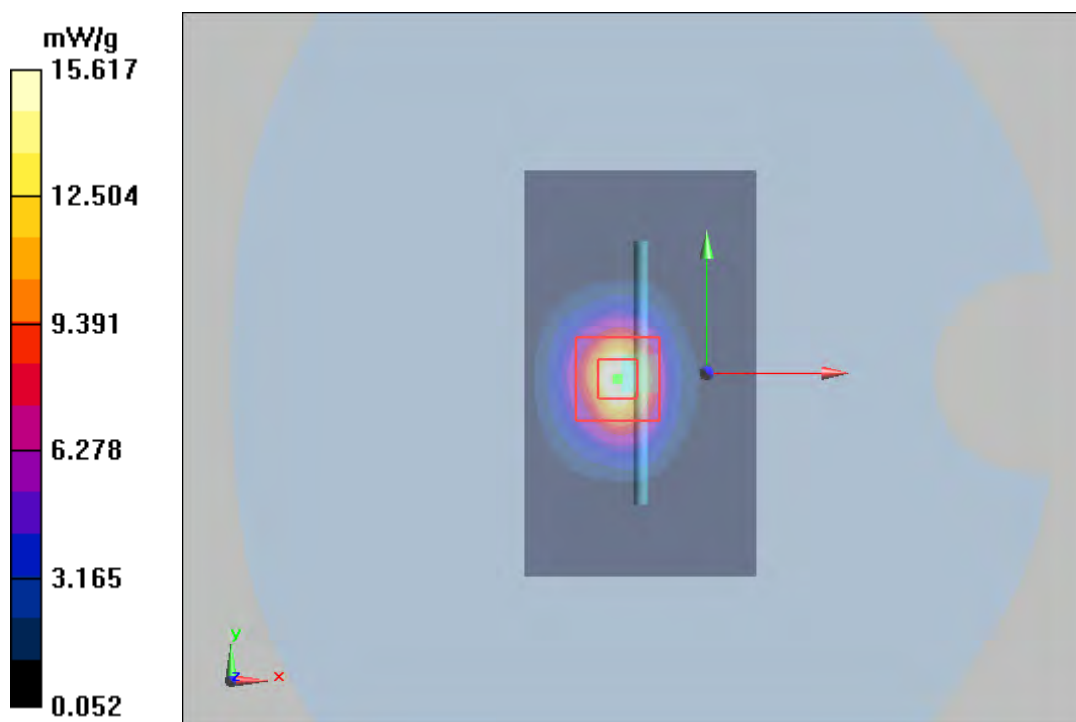

Plot 3 System Performance Check at 3700 MHz TSL

DUT: Dipole 3700 MHz; Type: D3700V2; Serial: D3700V2

Date: 3/23/2020

Communication System: UID 0, CW (0); Frequency: 3700 MHz; Duty Cycle: 1:1

Medium parameters used: $f = 3700$ MHz; $\sigma = 3.03$ S/m; $\epsilon_r = 37.9$; $\rho = 1000$ kg/m³

Ambient Temperature: 22.3 °C Liquid Temperature: 21.5 °C

Phantom section: Flat Section

DASY5 Configuration:

Sensor-Surface: 4mm (Mechanical Surface Detection)

Probe: EX3DV4 - SN7543; ConvF(6.57, 6.57, 6.57) @ 3700 MHz; Calibrated: 2019/8/5

Electronics: DAE4 SN1317; Calibrated: 10/23/2019

Phantom: SAM 1; Type: QD000P40CD; Serial: TP:1666

Measurement SW: DASY52, Version 52.10 (1); SEMCAD X Version 14.6.12 (7470)

d=10mm, Pin=250mW /Area Scan (4x4x1): Measurement grid: dx=12 mm, dy=12 mm

Maximum value of SAR (measured) = 13.6 W/kg

d=10mm, Pin=250mW/Zoom Scan (8x8x8)/Cube 0: Measurement grid: dx=4mm, dy=4mm, dz=4mm

Reference Value = 46.00 V/m; Power Drift = 0.10 dB

Peak SAR (extrapolated) = 18.2 W/kg

SAR(1 g) = 6.83 W/kg; SAR(10 g) = 2.51 W/kg

Maximum value of SAR (measured) = 12.9 W/kg

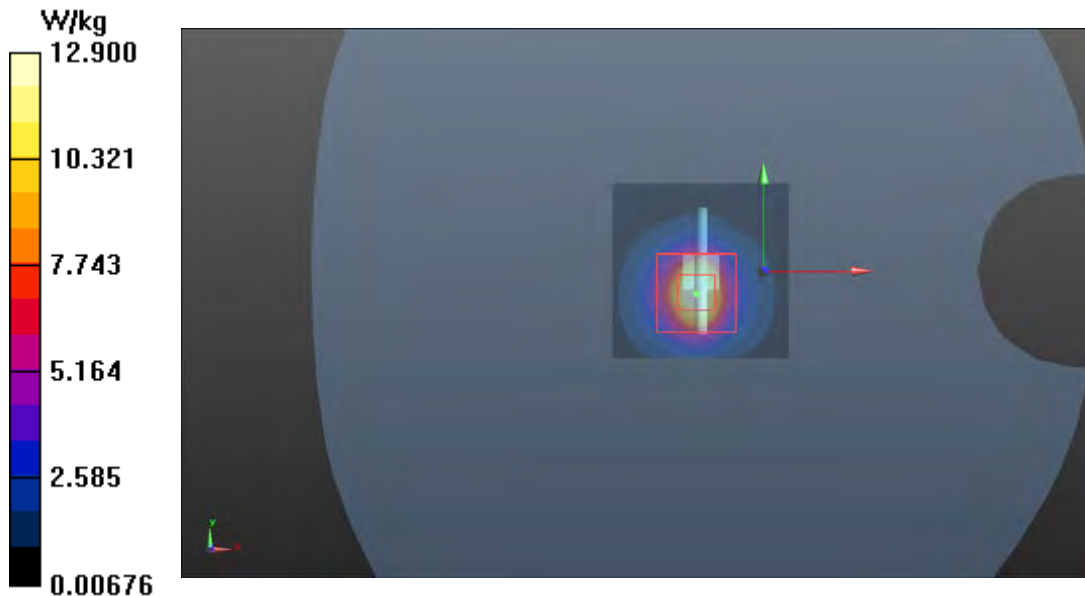

ANNEX C: Highest Graph Results

Plot 4 LTE Band 41 1RB Right Edge Low (Distance 0mm)

Date: 3/21/2020

Communication System: UID 0, LTE (0); Frequency: 2549 MHz; Duty Cycle: 1:1

Medium parameters used: $f = 2549$ MHz; $\sigma = 1.98$ S/m; $\epsilon_r = 40.445$; $\rho = 1000$ kg/m³

Ambient Temperature: 22.3 °C Liquid Temperature: 21.5 °C

Phantom section: Flat Section

DASY5 Configuration:

Sensor-Surface: 1.4mm (Mechanical Surface Detection)

Probe: EX3DV4 - SN3677; ConvF(7.20, 7.20, 7.20); Calibrated: 6/19/2019;

Electronics: DAE4 SN1317; Calibrated: 10/23/2019

Phantom: SAM1; Type: SAM; Serial: TP-1534

Measurement SW: DASY52, Version 52.10 (1); SEMCAD X Version 14.6.11 (7439)

Right Edge Low/Area Scan (9x23x1): Measurement grid: dx=10mm, dy=10mm

Maximum value of SAR (measured) = 1.09 W/kg

Right Edge Low/Zoom Scan (7x7x7)/Cube 0: Measurement grid: dx=5mm, dy=5mm, dz=5mm

Reference Value = 23.20 V/m; Power Drift = -0.046 dB

Peak SAR (extrapolated) = 2.08 W/kg

SAR(1 g) = 1.09 W/kg; SAR(10 g) = 0.568 W/kg

Maximum value of SAR (measured) = 1.18 W/kg

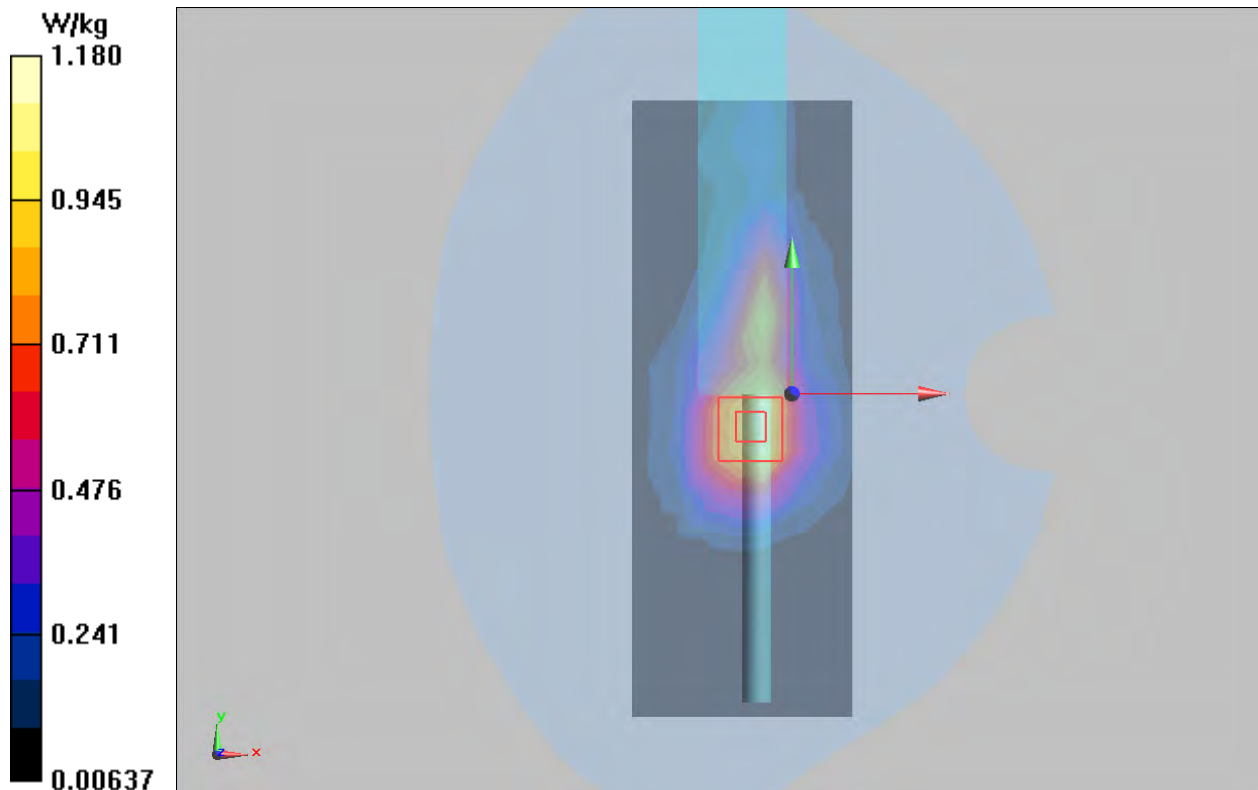

Plot 5 LTE Band 43 1RB Right Edge High (Distance 0mm)

Date: 3/23/2020

Communication System: UID 0, LTE (0); Frequency: 3790 MHz; Duty Cycle: 1:1

Medium parameters used (interpolated): $f = 3790$ MHz; $\sigma = 3.161$ S/m; $\epsilon_r = 37.736$; $\rho = 1000$ kg/m³

Ambient Temperature: 22.3 °C Liquid Temperature: 21.5 °C

Phantom section: Flat Section

DASY5 Configuration:

Sensor-Surface: 1.4mm (Mechanical Surface Detection)

Probe: EX3DV4 - SN7543; ConvF(6.57, 6.57, 6.57) @ 3700 MHz; Calibrated: 2019/8/5

Electronics: DAE4 SN1317; Calibrated: 10/23/2019

Phantom: SAM 1; Type: QD000P40CD; Serial: TP:1666

Measurement SW: DASY52, Version 52.10 (1); SEMCAD X Version 14.6.11 (7439)

Right Edge High/Area Scan (9x23x1): Measurement grid: dx=10mm, dy=10mm

Maximum value of SAR (measured) = 0.747 W/kg

Right Edge High/Zoom Scan(8x8x8)/Cube 0: Measurement grid: dx=4mm, dy=4mm, dz=4mm

Reference Value = 11.40 V/m; Power Drift = 0.12 dB

Peak SAR (extrapolated) = 3.17 W/kg

SAR(1 g) = 0.933 W/kg; SAR(10 g) = 0.297 W/kg

Maximum value of SAR (measured) = 1.09 W/kg

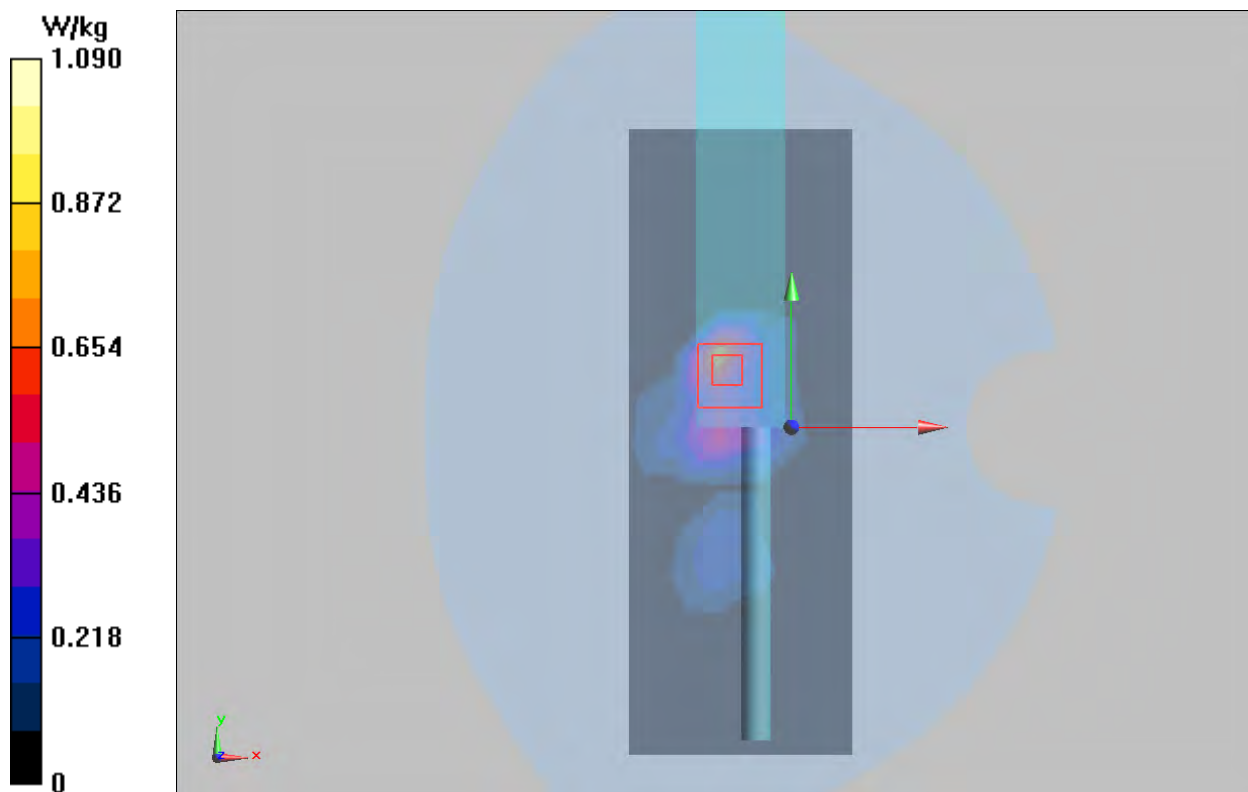

Plot 6 LTE Band 48 1RB Right Edge Middle (Distance 0mm)

Date: 3/23/2020

Communication System: UID 0, LTE (0); Frequency: 3675 MHz; Duty Cycle: 1:1

Medium parameters used (interpolated): $f = 3675$ MHz; $\sigma = 3.03$ S/m; $\epsilon_r = 37.997$; $\rho = 1000$ kg/m³

Ambient Temperature: 22.3 °C Liquid Temperature: 21.5 °C

Phantom section: Flat Section

DASY5 Configuration:

Sensor-Surface: 1.4mm (Mechanical Surface Detection)

Probe: EX3DV4 - SN7543; ConvF(6.57, 6.57, 6.57) @ 3700 MHz; Calibrated: 2019/8/5

Electronics: DAE4 SN1317; Calibrated: 10/23/2019

Phantom: SAM 1; Type: QD000P40CD; Serial: TP:1666

Measurement SW: DASY52, Version 52.10 (1); SEMCAD X Version 14.6.11 (7439)

Right Edge Middle/Area Scan (9x23x1): Measurement grid: dx=10mm, dy=10mm

Maximum value of SAR (measured) = 0.241 W/kg

Right Edge Middle/Zoom Scan (8x8x8)/Cube 0: Measurement grid: dx=4mm, dy=4mm, dz=4mm

Reference Value = 9.245 V/m; Power Drift = -0.033 dB

Peak SAR (extrapolated) = 0.810 W/kg

SAR(1 g) = 0.304 W/kg; SAR(10 g) = 0.128 W/kg

Maximum value of SAR (measured) = 0.303 W/kg

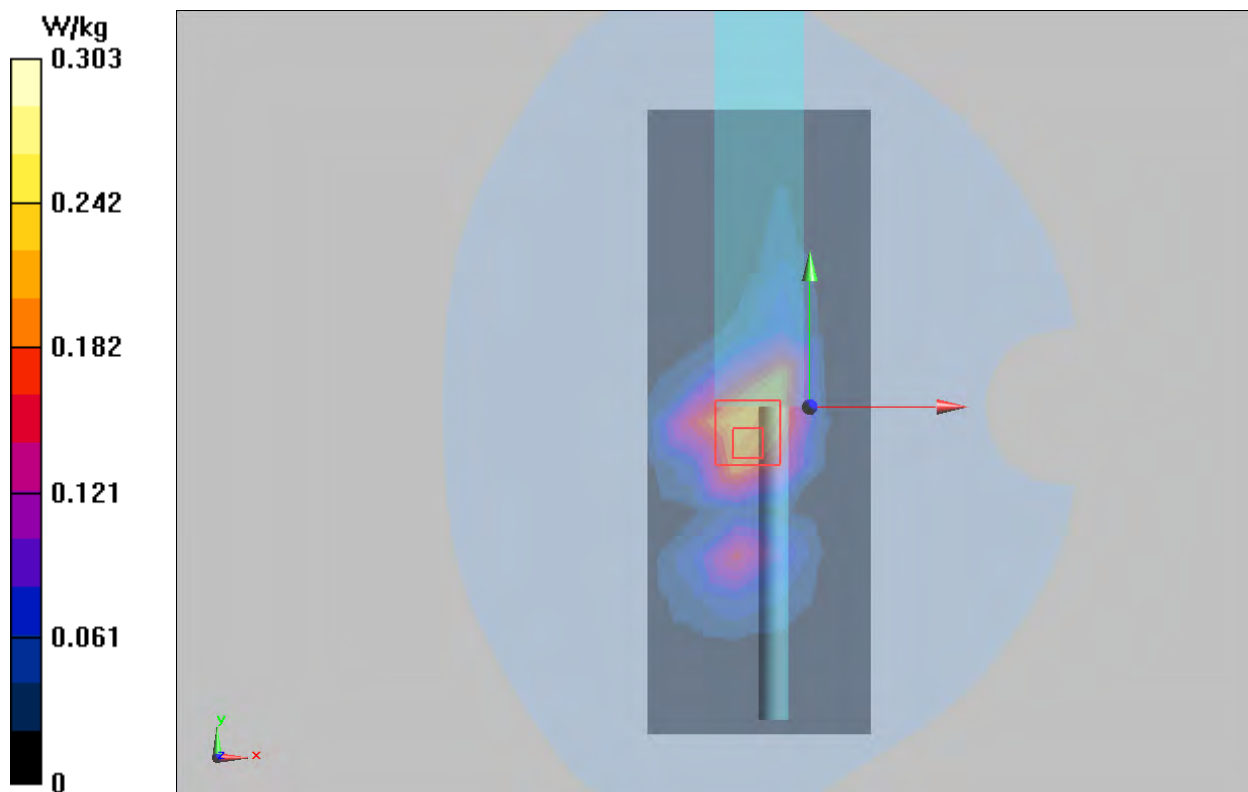

Plot 7 LTE Band 53 1RB Right Edge Middle (Distance 0mm)

Date: 3/20/2020

Communication System: UID 0, LTE (0); Frequency: 2489.2 MHz; Duty Cycle: 1:1

Medium parameters used (interpolated): $f = 2489.2$ MHz; $\sigma = 1.849$ S/m; $\epsilon_r = 39.209$; $\rho = 1000$ kg/m³

Ambient Temperature: 22.3 °C Liquid Temperature: 21.5°C

Phantom section: Flat Section

DASY5 Configuration:

Sensor-Surface: 1.4mm (Mechanical Surface Detection)

Probe: EX3DV4 - SN3677; ConvF(7.50, 7.50, 7.50); Calibrated: 6/19/2019;

Electronics: DAE4 SN1317; Calibrated: 10/23/2019

Phantom: SAM1; Type: SAM; Serial: TP-1534

Measurement SW: DASY52, Version 52.10 (1); SEMCAD X Version 14.6.11 (7439)

Right Edge Middle/Area Scan (9x23x1): Measurement grid: dx=10mm, dy=10mm

Maximum value of SAR (measured) = 0.777 W/kg

Right Edge Middle /Zoom Scan (7x7x7)/Cube 0: Measurement grid: dx=5mm, dy=5mm, dz=5mm

Reference Value = 17.39 V/m; Power Drift = -0.020 dB

Peak SAR (extrapolated) = 1.53 W/kg

SAR(1 g) = 0.773 W/kg; SAR(10 g) = 0.361 W/kg

Maximum value of SAR (measured) = 0.885 W/kg

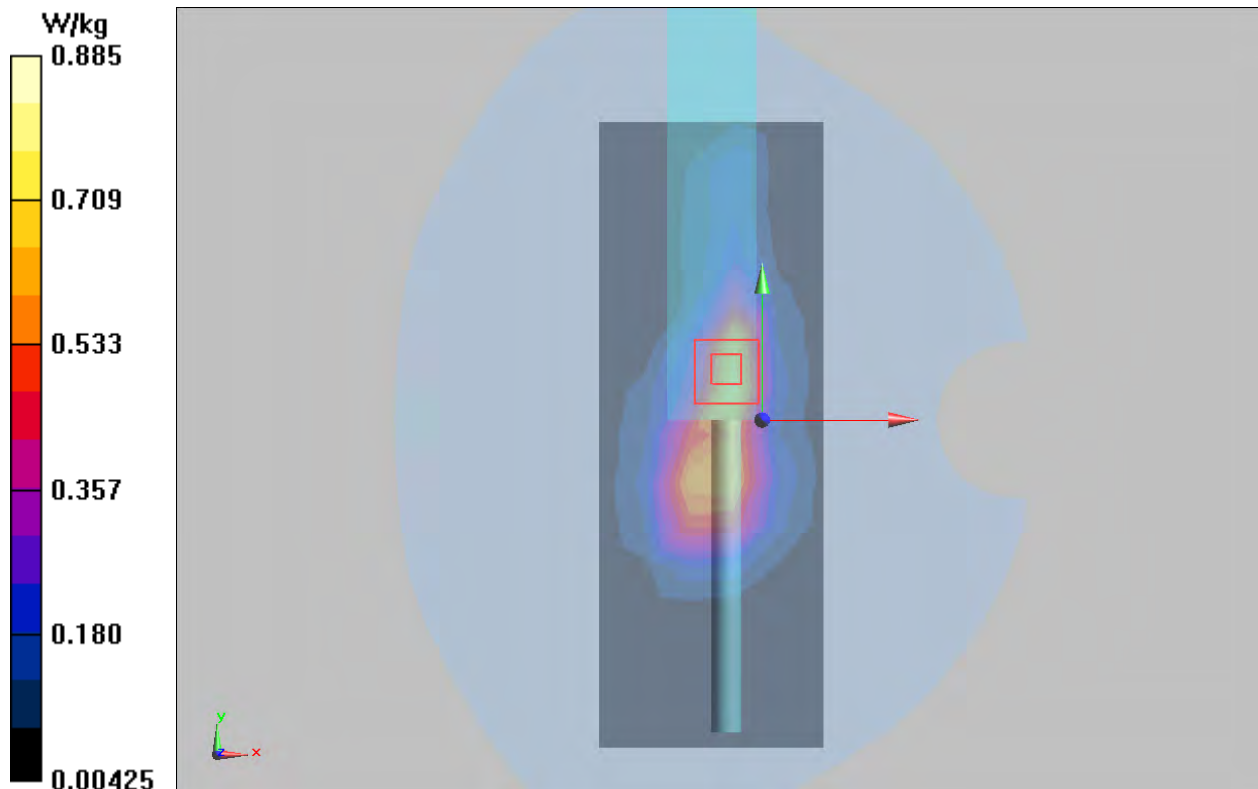



ANNEX D: Probe Calibration Certificate(3677)



In Collaboration with
s p e a g
CALIBRATION LABORATORY



中国认可
国际互认
校准
CALIBRATION
CNAS L0570

Add: No.51 Xueyuan Road, Haidian District, Beijing, 100191, China
Tel: +86-10-62304633-2512 Fax: +86-10-62304633-2504
E-mail: cttl@chinattl.com <http://www.chinattl.cn>

Client

TA(Shanghai)

Certificate No: Z19-60169

CALIBRATION CERTIFICATE

Object EX3DV4 - SN:3677

Calibration Procedure(s) FF-Z11-004-01
Calibration Procedures for Dosimetric E-field Probes

Calibration date: June 19, 2019

This calibration Certificate documents the traceability to national standards, which realize the physical units of measurements(SI). The measurements and the uncertainties with confidence probability are given on the following pages and are part of the certificate.

All calibrations have been conducted in the closed laboratory facility: environment temperature(22±3)°C and humidity<70%.

Calibration Equipment used (M&TE critical for calibration)

Primary Standards	ID #	Cal Date(Calibrated by, Certificate No.)	Scheduled Calibration
Power Meter NRP2	101919	20-Jun-18 (CTTL, No.J18X05032)	Jun-19
Power sensor NRP-Z91	101547	20-Jun-18 (CTTL, No.J18X05032)	Jun-19
Power sensor NRP-Z91	101548	20-Jun-18 (CTTL, No.J18X05032)	Jun-19
Reference10dBAttenuator	18N50W-10dB	09-Feb-18(CTTL, No.J18X01133)	Feb-20
Reference20dBAttenuator	18N50W-20dB	09-Feb-18(CTTL, No.J18X01132)	Feb-20
Reference Probe EX3DV4	SN 3617	31-Jan-19(SPEAG,No.EX3-3617_Jan19)	Jan-20
DAE4	SN 1331	06-Feb-19(SPEAG, No.DAE4-1331_Feb19)	Feb -20
Secondary Standards	ID #	Cal Date(Calibrated by, Certificate No.)	Scheduled Calibration
SignalGeneratorMG3700A	6201052605	21-Jun-18 (CTTL, No.J18X05033)	Jun-19
Network Analyzer E5071C	MY46110673	24-Jan-19 (CTTL, No.J19X00547)	Jan -20

	Name	Function	Signature
Calibrated by:	Yu Zongying	SAR Test Engineer	
Reviewed by:	Lin Hao	SAR Test Engineer	
Approved by:	Qi Dianyuan	SAR Project Leader	

Issued: June 20, 2019

This calibration certificate shall not be reproduced except in full without written approval of the laboratory.

Certificate No: Z19-60169

Page 1 of 11



Add: No.51 Xueyuan Road, Haidian District, Beijing, 100191, China
 Tel: +86-10-62304633-2512 Fax: +86-10-62304633-2504
 E-mail: ettl@chinattl.com [Http://www.chinattl.cn](http://www.chinattl.cn)

Glossary:

- TSL tissue simulating liquid
- NORM_{x,y,z} sensitivity in free space
- ConvF sensitivity in TSL / NORM_{x,y,z}
- DCP diode compression point
- CF crest factor (1/duty_cycle) of the RF signal
- A,B,C,D modulation dependent linearization parameters
- Polarization Φ Φ rotation around probe axis
- Polarization θ θ rotation around an axis that is in the plane normal to probe axis (at measurement center), i
 $\theta=0$ is normal to probe axis

Connector Angle information used in DASY system to align probe sensor X to the robot coordinate system

Calibration is Performed According to the Following Standards:

- a) IEEE Std 1528-2013, "IEEE Recommended Practice for Determining the Peak Spatial-Averaged Specific Absorption Rate (SAR) in the Human Head from Wireless Communications Devices: Measurement Techniques", June 2013
- b) IEC 62209-1, "Measurement procedure for the assessment of Specific Absorption Rate (SAR) from hand-held and body-mounted devices used next to the ear (frequency range of 300 MHz to 6 GHz)", July 2016
- c) IEC 62209-2, "Procedure to determine the Specific Absorption Rate (SAR) for wireless communication devices used in close proximity to the human body (frequency range of 30 MHz to 6 GHz)", March 2010
- d) KDB 865664, "SAR Measurement Requirements for 100 MHz to 6 GHz"

Methods Applied and Interpretation of Parameters:

- NORM_{x,y,z}: Assessed for E-field polarization $\theta=0$ ($f \leq 900$ MHz in TEM-cell; $f > 1800$ MHz: waveguide). NORM_{x,y,z} are only intermediate values, i.e., the uncertainties of NORM_{x,y,z} does not effect the E^2 -field uncertainty inside TSL (see below ConvF).
- NORM(f)_{x,y,z} = NORM_{x,y,z}* frequency_response (see Frequency Response Chart). This linearization is implemented in DASY4 software versions later than 4.2. The uncertainty of the frequency response is included in the stated uncertainty of ConvF.
- DCP_{x,y,z}: DCP are numerical linearization parameters assessed based on the data of power sweep (no uncertainty required). DCP does not depend on frequency nor media.
- PAR: PAR is the Peak to Average Ratio that is not calibrated but determined based on the signal characteristics.
- A_{x,y,z}; B_{x,y,z}; C_{x,y,z}; VR_{x,y,z}: A,B,C are numerical linearization parameters assessed based on the data of power sweep for specific modulation signal. The parameters do not depend on frequency nor media. VR is the maximum calibration range expressed in RMS voltage across the diode.
- ConvF and Boundary Effect Parameters: Assessed in flat phantom using E-field (or Temperature Transfer Standard for $f \leq 800$ MHz) and inside waveguide using analytical field distributions based on power measurements for $f > 800$ MHz. The same setups are used for assessment of the parameters applied for boundary compensation (alpha, depth) of which typical uncertainty valued are given. These parameters are used in DASY4 software to improve probe accuracy close to the boundary. The sensitivity in TSL corresponds to NORM_{x,y,z}* ConvF whereby the uncertainty corresponds to that given for ConvF. A frequency dependent ConvF is used in DASY version 4.4 and higher which allows extending the validity from ± 50 MHz to ± 100 MHz.
- Spherical isotropy (3D deviation from isotropy): in a field of low gradients realized using a flat phantom exposed by a patch antenna.
- Sensor Offset: The sensor offset corresponds to the offset of virtual measurement center from the probe tip (on probe axis). No tolerance required.
- Connector Angle: The angle is assessed using the information gained by determining the NORM_x (no uncertainty required).



Add: No.51 Xueyuan Road, Haidian District, Beijing, 100191, China
Tel: +86-10-62304633-2512 Fax: +86-10-62304633-2504
E-mail: cttl@chinattl.com [Http://www.chinattl.cn](http://www.chinattl.cn)

Probe EX3DV4

SN: 3677

Calibrated: June 19, 2019

Calibrated for DASY/EASY Systems

(Note: non-compatible with DASY2 system!)

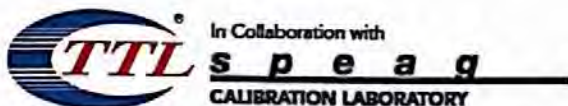

Add: No.51 Xueyuan Road, Haidian District, Beijing, 100191, China
Tel: +86-10-62304633-2512 Fax: +86-10-62304633-2504
E-mail: ttl@chinattl.com [Http://www.chinattl.cn](http://www.chinattl.cn)

DASY/EASY – Parameters of Probe: EX3DV4 – SN: 3677

Basic Calibration Parameters

	Sensor X	Sensor Y	Sensor Z	Unc (k=2)
Norm($\mu\text{V}/(\text{V}/\text{m})^2$) ^A	0.41	0.46	0.40	$\pm 10.0\%$
DCP(mV) ^B	101.1	102.9	101.9	

Modulation Calibration Parameters

UID	Communication System Name		A dB	B dB $\sqrt{\mu\text{V}}$	C	D dB	VR mV	Unc ^E (k=2)
0	CW	X	0.0	0.0	1.0	0.00	152.0	$\pm 2.6\%$
		Y	0.0	0.0	1.0		170.1	
		Z	0.0	0.0	1.0		147.7	

The reported uncertainty of measurement is stated as the standard uncertainty of Measurement multiplied by the coverage factor k=2, which for a normal distribution Corresponds to a coverage probability of approximately 95%.

^A The uncertainties of Norm X, Y, Z do not affect the E²-field uncertainty inside TSL (see Page 5 and Page 6).

^B Numerical linearization parameter: uncertainty not required.

^E Uncertainty is determined using the max. deviation from linear response applying rectangular distribution and is expressed for the square of the field value.



Add: No.51 Xueyuan Road, Haidian District, Beijing, 100191, China
 Tel: +86-10-62304633-2512 Fax: +86-10-62304633-2504
 E-mail: cttl@chinattl.com [Http://www.chinattl.cn](http://www.chinattl.cn)

DASY/EASY – Parameters of Probe: EX3DV4 – SN: 3677

Calibration Parameter Determined in Head Tissue Simulating Media

f [MHz] ^C	Relative Permittivity ^F	Conductivity (S/m) ^F	ConvF X	ConvF Y	ConvF Z	Alpha ^G	Depth ^G (mm)	Unct. (k=2)
750	41.9	0.89	9.54	9.54	9.54	0.11	1.56	±12.1%
835	41.5	0.90	9.20	9.20	9.20	0.11	1.61	±12.1%
1750	40.1	1.37	8.21	8.21	8.21	0.22	1.11	±12.1%
1900	40.0	1.40	7.79	7.79	7.79	0.22	1.04	±12.1%
2300	39.5	1.67	7.66	7.66	7.66	0.57	0.72	±12.1%
2450	39.2	1.80	7.50	7.50	7.50	0.59	0.71	±12.1%
2600	39.0	1.96	7.20	7.20	7.20	0.65	0.68	±12.1%
5250	35.9	4.71	5.56	5.56	5.56	0.40	1.40	±13.3%
5600	35.5	5.07	4.90	4.90	4.90	0.45	1.40	±13.3%
5750	35.4	5.22	4.99	4.99	4.99	0.50	1.35	±13.3%

^C Frequency validity above 300 MHz of ±100MHz only applies for DASY v4.4 and higher (Page 2), else it is restricted to ±50MHz. The uncertainty is the RSS of ConvF uncertainty at calibration frequency and the uncertainty for the indicated frequency band. Frequency validity below 300 MHz is ± 10, 25, 40, 50 and 70 MHz for ConvF assessments at 30, 64, 128, 150 and 220 MHz respectively. Above 5 GHz frequency validity can be extended to ± 110 MHz.

^F At frequency below 3 GHz, the validity of tissue parameters (ϵ and σ) can be relaxed to ±10% if liquid compensation formula is applied to measured SAR values. At frequencies above 3 GHz, the validity of tissue parameters (ϵ and σ) is restricted to ±5%. The uncertainty is the RSS of the ConvF uncertainty for indicated target tissue parameters.

^G Alpha/Depth are determined during calibration. SPEAG warrants that the remaining deviation due to the boundary effect after compensation is always less than ± 1% for frequencies below 3 GHz and below ± 2% for the frequencies between 3-6 GHz at any distance larger than half the probe tip diameter from the boundary.



Add: No.51 Xueyuan Road, Haidian District, Beijing, 100191, China
 Tel: +86-10-62304633-2512 Fax: +86-10-62304633-2504
 E-mail: cttl@chinattl.com [Http://www.chinattl.cn](http://www.chinattl.cn)

DASY/EASY – Parameters of Probe: EX3DV4 – SN: 3677

Calibration Parameter Determined in Body Tissue Simulating Media

f [MHz] ^C	Relative Permittivity ^F	Conductivity (S/m) ^F	ConvF X	ConvF Y	ConvF Z	Alpha ^G	Depth ^G (mm)	Unct. (k=2)
750	55.5	0.96	9.75	9.75	9.75	0.40	0.75	±12.1%
835	55.2	0.97	9.40	9.40	9.40	0.18	1.38	±12.1%
1750	53.4	1.49	7.86	7.86	7.86	0.23	1.09	±12.1%
1900	53.3	1.52	7.62	7.62	7.62	0.22	1.15	±12.1%
2300	52.9	1.81	7.67	7.67	7.67	0.55	0.81	±12.1%
2450	52.7	1.95	7.57	7.57	7.57	0.59	0.75	±12.1%
2600	52.5	2.16	7.33	7.33	7.33	0.74	0.65	±12.1%
5250	48.9	5.36	4.93	4.93	4.93	0.45	1.55	±13.3%
5600	48.5	5.77	4.24	4.24	4.24	0.50	1.45	±13.3%
5750	48.3	5.94	4.35	4.35	4.35	0.50	1.50	±13.3%

^C Frequency validity above 300 MHz of ±100MHz only applies for DASY v4.4 and higher (Page 2), else it is restricted to ±50MHz. The uncertainty is the RSS of ConvF uncertainty at calibration frequency and the uncertainty for the indicated frequency band. Frequency validity below 300 MHz is ± 10, 25, 40, 50 and 70 MHz for ConvF assessments at 30, 64, 128, 150 and 220 MHz respectively. Above 5 GHz frequency validity can be extended to ± 110 MHz.

^F At frequency below 3 GHz, the validity of tissue parameters (ϵ and σ) can be relaxed to ±10% if liquid compensation formula is applied to measured SAR values. At frequencies above 3 GHz, the validity of tissue parameters (ϵ and σ) is restricted to ±5%. The uncertainty is the RSS of the ConvF uncertainty for indicated target tissue parameters.

^G Alpha/Depth are determined during calibration. SPEAG warrants that the remaining deviation due to the boundary effect after compensation is always less than ± 1% for frequencies below 3 GHz and below ± 2% for the frequencies between 3-6 GHz at any distance larger than half the probe tip diameter from the boundary.



Add: No.51 Xueyuan Road, Haidian District, Beijing, 100191, China
Tel: +86-10-62304633-2512 Fax: +86-10-62304633-2504
E-mail: cttl@chinattl.com [Http://www.chinattl.cn](http://www.chinattl.cn)

Frequency Response of E-Field (TEM-Cell: ifi110 EXX, Waveguide: R22)

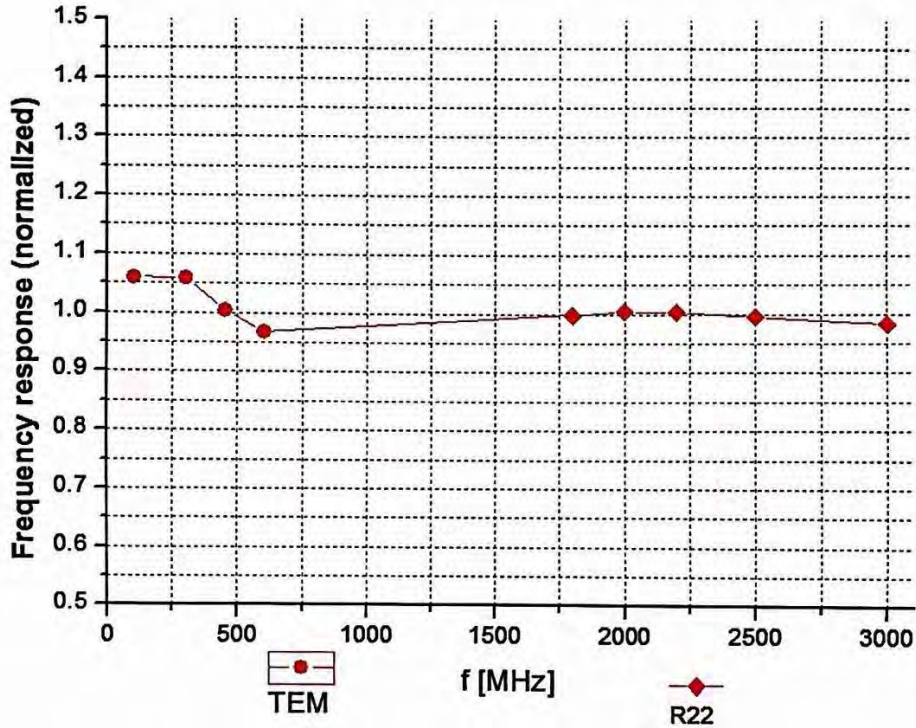

Uncertainty of Frequency Response of E-field: $\pm 7.4\%$ (k=2)

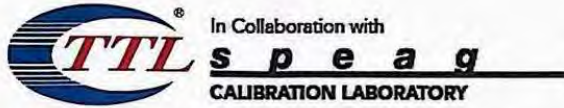

Add: No.51 Xueyuan Road, Haidian District, Beijing, 100191, China
Tel: +86-10-62304633-2512 Fax: +86-10-62304633-2504
E-mail: cttl@chinattl.com [Http://www.chinattl.cn](http://www.chinattl.cn)

Receiving Pattern (Φ), $\theta=0^\circ$

f=600 MHz, TEM

f=1800 MHz, R22

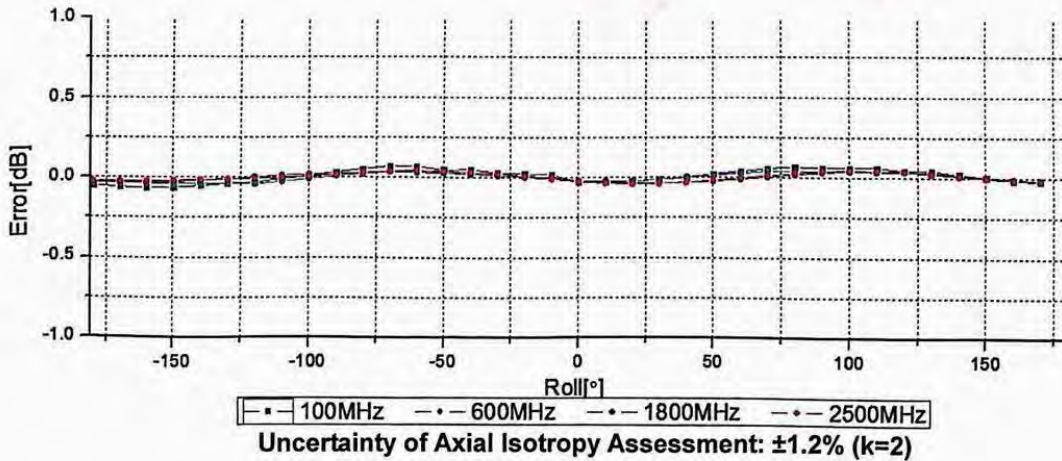
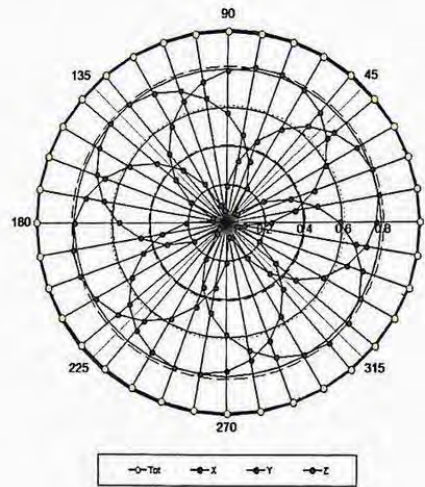
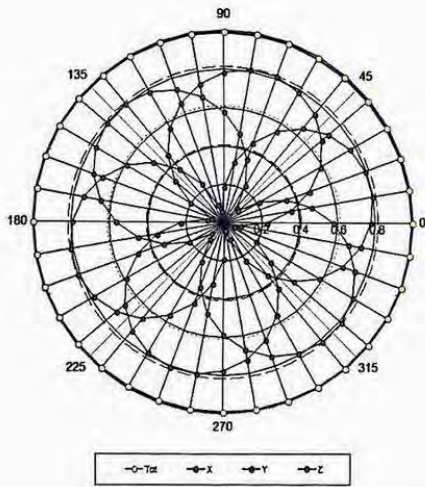

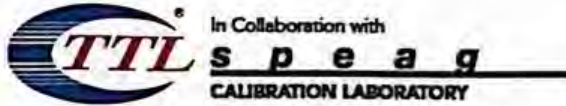

Add: No.51 Xueyuan Road, Haidian District, Beijing, 100191, China
Tel: +86-10-62304633-2512 Fax: +86-10-62304633-2504
E-mail: cttl@chinattl.com [Http://www.chinattl.cn](http://www.chinattl.cn)

Dynamic Range f(SAR_{head}) (TEM cell, f = 900 MHz)

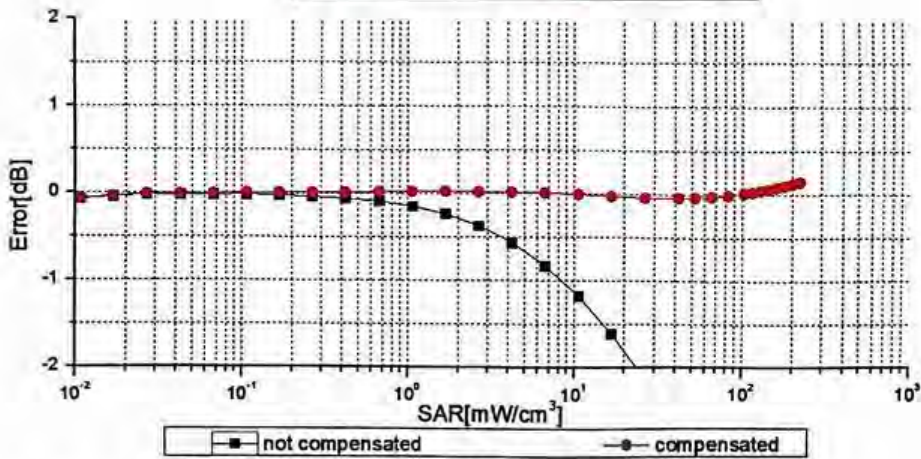
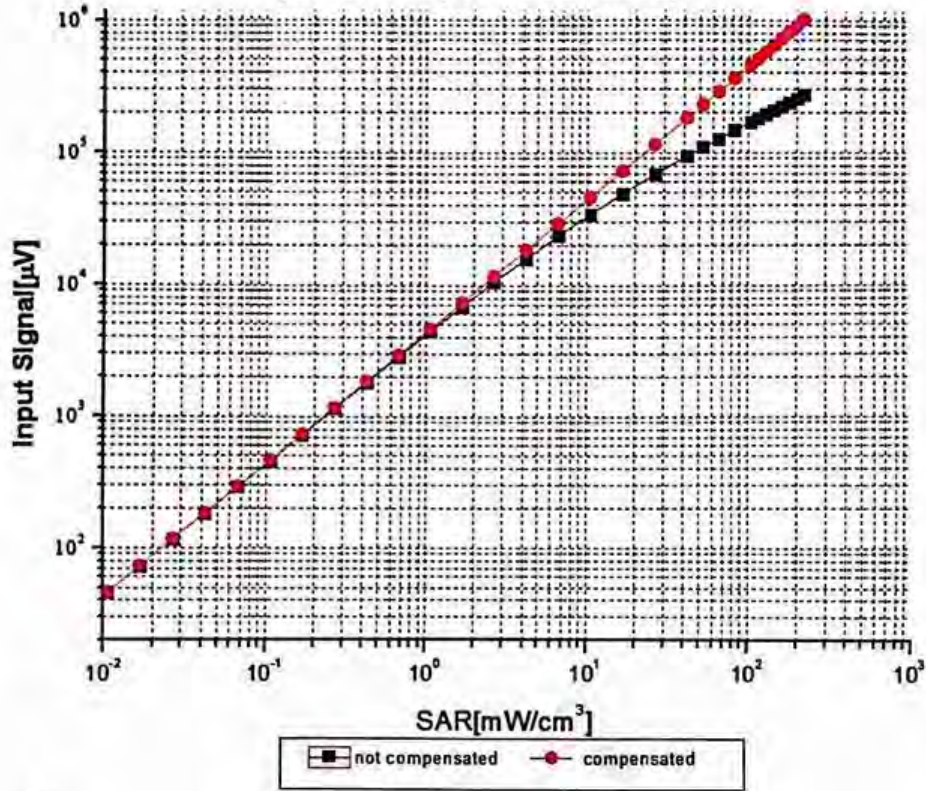

Uncertainty of Linearity Assessment: ±0.9% (k=2)

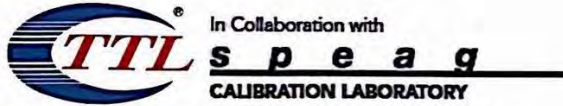

Add: No.51 Xueyuan Road, Haidian District, Beijing, 100191, China
Tel: +86-10-62304633-2512 Fax: +86-10-62304633-2504
E-mail: cttl@chinattl.com [Http://www.chinattl.cn](http://www.chinattl.cn)

Conversion Factor Assessment

f=750 MHz, WGLS R9(H_convF)

f=1750 MHz, WGLS R22(H_convF)

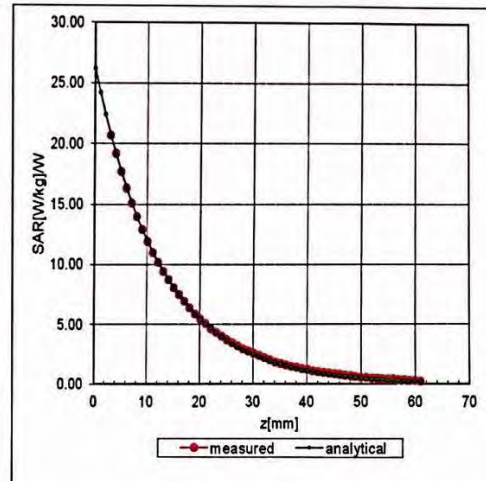
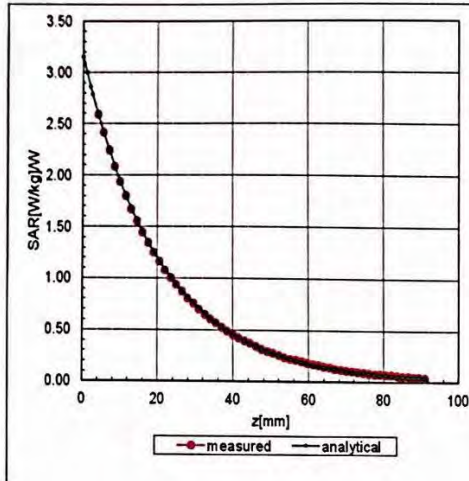

Deviation from Isotropy in Liquid

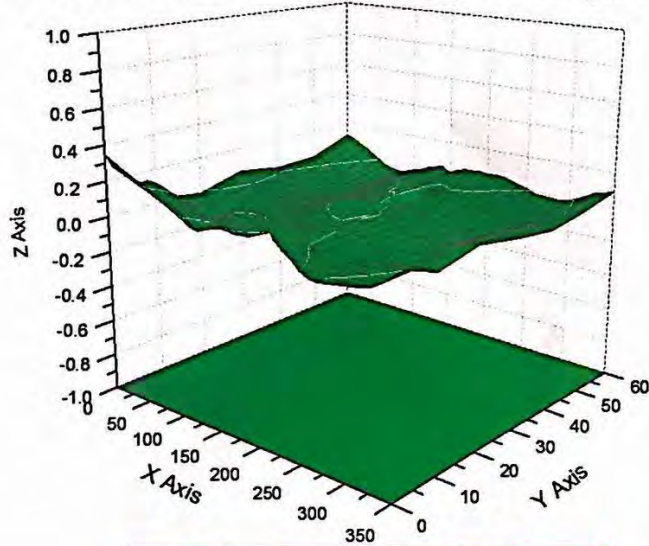

Uncertainty of Spherical Isotropy Assessment: $\pm 3.2\%$ (K=2)

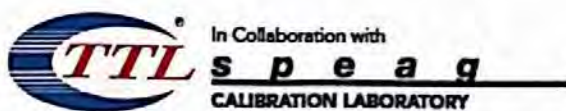

Add: No.51 Xueyuan Road, Haidian District, Beijing, 100191, China
 Tel: +86-10-62304633-2512 Fax: +86-10-62304633-2504
 E-mail: cttl@chinattl.com [Http://www.chinattl.cn](http://www.chinattl.cn)

DASY/EASY – Parameters of Probe: EX3DV4 – SN: 3677

Other Probe Parameters

Sensor Arrangement	Triangular
Connector Angle (°)	117.9
Mechanical Surface Detection Mode	enabled
Optical Surface Detection Mode	disable
Probe Overall Length	337mm
Probe Body Diameter	10mm
Tip Length	9mm
Tip Diameter	2.5mm
Probe Tip to Sensor X Calibration Point	1mm
Probe Tip to Sensor Y Calibration Point	1mm
Probe Tip to Sensor Z Calibration Point	1mm
Recommended Measurement Distance from Surface	1.4mm



ANNEX E: Probe Calibration Certificate(7543)

**Calibration Laboratory of
Schmid & Partner
Engineering AG**
Zeughausstrasse 43, 8004 Zurich, Switzerland



S Schweizerischer Kalibrierdienst
C Service suisse d'étalonnage
S Servizio svizzero di taratura
S Swiss Calibration Service

Accredited by the Swiss Accreditation Service (SAS)
The Swiss Accreditation Service is one of the signatories to the EA
Multilateral Agreement for the recognition of calibration certificates

Accreditation No.: **SCS 0108**

Client **TA-SH (Auden)**

Certificate No: **EX3-7543_Aug19**

CALIBRATION CERTIFICATE

Object **EX3DV4 - SN:7543**

Calibration procedure(s) **QA CAL-01.v9, QA CAL-14.v5, QA CAL-23.v5, QA CAL-25.v7
Calibration procedure for dosimetric E-field probes**

Calibration date: **August 5, 2019**

This calibration certificate documents the traceability to national standards, which realize the physical units of measurements (SI).
The measurements and the uncertainties with confidence probability are given on the following pages and are part of the certificate.

All calibrations have been conducted in the closed laboratory facility: environment temperature (22 ± 3)°C and humidity < 70%.

Calibration Equipment used (M&TE critical for calibration)

Primary Standards	ID	Cal Date (Certificate No.)	Scheduled Calibration
Power meter NRP	SN: 104778	03-Apr-19 (No. 217-02892/02893)	Apr-20
Power sensor NRP-Z91	SN: 103244	03-Apr-19 (No. 217-02892)	Apr-20
Power sensor NRP-Z91	SN: 103245	03-Apr-19 (No. 217-02893)	Apr-20
Reference 20 dB Attenuator	SN: S5277 (20x)	04-Apr-19 (No. 217-02894)	Apr-20
DAE4	SN: 660	19-Dec-18 (No. DAE4-660 Dec18)	Dec-19
Reference Probe ES3DV2	SN: 3013	31-Dec-18 (No. ES3-3013 Dec18)	Dec-19
Secondary Standards	ID	Check Date (in house)	Scheduled Check
Power meter E4419B	SN: GB41293874	06-Apr-16 (in house check Jun-18)	In house check Jun-20
Power sensor E4412A	SN: MY41498087	06-Apr-16 (in house check Jun-18)	In house check Jun-20
Power sensor E4412A	SN: 000110210	06-Apr-16 (in house check Jun-18)	In house check Jun-20
RF generator HP 8648C	SN: US3642U01700	04-Aug-99 (in house check Jun-18)	In house check Jun-20
Network Analyzer E8358A	SN: US41080477	31-Mar-14 (in house check Oct-18)	In house check Oct-19

Calibrated by:	Name Claudio Leubler	Function Laboratory Technician	Signature
Approved by:	Name Katja Pokovic	Function Technical Manager	Signature

Issued: August 5, 2019

This calibration certificate shall not be reproduced except in full without written approval of the laboratory.

**Calibration Laboratory of
Schmid & Partner
Engineering AG**
Zeughausstrasse 43, 8004 Zurich, Switzerland



S Schweizerischer Kalibrierdienst
C Service suisse d'étalonnage
S Servizio svizzero di taratura
S Swiss Calibration Service

Accredited by the Swiss Accreditation Service (SAS)

Accreditation No.: **SCS 0108**

The Swiss Accreditation Service is one of the signatories to the EA Multilateral Agreement for the recognition of calibration certificates

Glossary:

TSL	tissue simulating liquid
NORM _{x,y,z}	sensitivity in free space
ConvF	sensitivity in TSL / NORM _{x,y,z}
DCP	diode compression point
CF	crest factor (1/duty_cycle) of the RF signal
A, B, C, D	modulation dependent linearization parameters
Polarization φ	φ rotation around probe axis
Polarization ϑ	ϑ rotation around an axis that is in the plane normal to probe axis (at measurement center), i.e., $\vartheta = 0$ is normal to probe axis
Connector Angle	information used in DASY system to align probe sensor X to the robot coordinate system

Calibration is Performed According to the Following Standards:

- a) IEEE Std 1528-2013, "IEEE Recommended Practice for Determining the Peak Spatial-Averaged Specific Absorption Rate (SAR) in the Human Head from Wireless Communications Devices: Measurement Techniques", June 2013
- b) IEC 62209-1, "Measurement procedure for the assessment of Specific Absorption Rate (SAR) from hand-held and body-mounted devices used next to the ear (frequency range of 300 MHz to 6 GHz)", July 2016
- c) IEC 62209-2, "Procedure to determine the Specific Absorption Rate (SAR) for wireless communication devices used in close proximity to the human body (frequency range of 30 MHz to 6 GHz)", March 2010
- d) KDB 865664, "SAR Measurement Requirements for 100 MHz to 6 GHz"

Methods Applied and Interpretation of Parameters:

- **NORM_{x,y,z}**: Assessed for E-field polarization $\vartheta = 0$ ($f \leq 900$ MHz in TEM-cell; $f > 1800$ MHz: R22 waveguide). NORM_{x,y,z} are only intermediate values, i.e., the uncertainties of NORM_{x,y,z} does not affect the E²-field uncertainty inside TSL (see below ConvF).
- **NORM(f)_{x,y,z}** = NORM_{x,y,z} * frequency_response (see Frequency Response Chart). This linearization is implemented in DASY4 software versions later than 4.2. The uncertainty of the frequency response is included in the stated uncertainty of ConvF.
- **DCP_{x,y,z}**: DCP are numerical linearization parameters assessed based on the data of power sweep with CW signal (no uncertainty required). DCP does not depend on frequency nor media.
- **PAR**: PAR is the Peak to Average Ratio that is not calibrated but determined based on the signal characteristics
- **A_{x,y,z}; B_{x,y,z}; C_{x,y,z}; D_{x,y,z}; VR_{x,y,z}**: A, B, C, D are numerical linearization parameters assessed based on the data of power sweep for specific modulation signal. The parameters do not depend on frequency nor media. VR is the maximum calibration range expressed in RMS voltage across the diode.
- **ConvF and Boundary Effect Parameters**: Assessed in flat phantom using E-field (or Temperature Transfer Standard for $f \leq 800$ MHz) and inside waveguide using analytical field distributions based on power measurements for $f > 800$ MHz. The same setups are used for assessment of the parameters applied for boundary compensation (alpha, depth) of which typical uncertainty values are given. These parameters are used in DASY4 software to improve probe accuracy close to the boundary. The sensitivity in TSL corresponds to NORM_{x,y,z} * ConvF whereby the uncertainty corresponds to that given for ConvF. A frequency dependent ConvF is used in DASY version 4.4 and higher which allows extending the validity from ± 50 MHz to ± 100 MHz.
- **Spherical isotropy (3D deviation from isotropy)**: in a field of low gradients realized using a flat phantom exposed by a patch antenna.
- **Sensor Offset**: The sensor offset corresponds to the offset of virtual measurement center from the probe tip (on probe axis). No tolerance required.
- **Connector Angle**: The angle is assessed using the information gained by determining the NORM_x (no uncertainty required).



EX3DV4 – SN:7543

August 5, 2019

DASY/EASY - Parameters of Probe: EX3DV4 - SN:7543**Basic Calibration Parameters**

	Sensor X	Sensor Y	Sensor Z	Unc (k=2)
Norm ($\mu\text{V}/(\text{V}/\text{m})^2$) ^A	0.59	0.63	0.56	± 10.1 %
DCP (mV) ^B	100.3	102.3	97.9	

Calibration Results for Modulation Response

UID	Communication System Name		A dB	B dB $\sqrt{\mu\text{V}}$	C	D dB	VR mV	Max dev.	Unc ^E (k=2)
0	CW	X	0.0	0.0	1.0	0.00	179.9	±3.0 %	± 4.7 %
		Y	0.0	0.0	1.0		197.1		
		Y	0.0	0.0	1.0		196.2		

The reported uncertainty of measurement is stated as the standard uncertainty of measurement multiplied by the coverage factor k=2, which for a normal distribution corresponds to a coverage probability of approximately 95%.

^A The uncertainties of Norm X,Y,Z do not affect the E²-field uncertainty inside TSL (see Pages 5 and 6).

^B Numerical linearization parameter: uncertainty not required.

^E Uncertainty is determined using the max. deviation from linear response applying rectangular distribution and is expressed for the square of the field value.



EX3DV4- SN:7543

August 5, 2019

DASY/EASY - Parameters of Probe: EX3DV4 - SN:7543**Other Probe Parameters**

Sensor Arrangement	Triangular
Connector Angle (°)	55.3
Mechanical Surface Detection Mode	enabled
Optical Surface Detection Mode	disabled
Probe Overall Length	337 mm
Probe Body Diameter	10 mm
Tip Length	9 mm
Tip Diameter	2.5 mm
Probe Tip to Sensor X Calibration Point	1 mm
Probe Tip to Sensor Y Calibration Point	1 mm
Probe Tip to Sensor Z Calibration Point	1 mm
Recommended Measurement Distance from Surface	1.4 mm



EX3DV4- SN:7543

August 5, 2019

DASY/EASY - Parameters of Probe: EX3DV4 - SN:7543**Calibration Parameter Determined in Head Tissue Simulating Media**

f (MHz) ^C	Relative Permittivity ^F	Conductivity (S/m) ^F	ConvF X	ConvF Y	ConvF Z	Alpha ^G	Depth ^G (mm)	Unc (k=2)
750	41.9	0.89	10.18	10.18	10.18	0.52	0.82	± 12.0 %
835	41.5	0.90	9.89	9.89	9.89	0.49	0.85	± 12.0 %
1750	40.1	1.37	8.44	8.44	8.44	0.30	0.80	± 12.0 %
1950	40.0	1.40	7.98	7.98	7.98	0.31	0.80	± 12.0 %
3300	38.2	2.71	6.72	6.72	6.72	0.40	1.30	± 13.1 %
3500	37.9	2.91	6.62	6.62	6.62	0.40	1.30	± 13.1 %
3700	37.7	3.12	6.57	6.57	6.57	0.40	1.30	± 13.1 %
3900	37.5	3.32	6.33	6.33	6.33	0.40	1.50	± 13.1 %
4100	37.2	3.53	6.00	6.00	6.00	0.40	1.50	± 13.1 %
4400	36.9	3.84	5.98	5.98	5.98	0.40	1.60	± 13.1 %
4600	36.7	4.04	5.90	5.90	5.90	0.40	1.80	± 13.1 %
4800	36.4	4.25	5.62	5.62	5.62	0.40	1.80	± 13.1 %
4950	36.3	4.40	5.59	5.59	5.59	0.40	1.80	± 13.1 %
5250	35.9	4.71	5.32	5.32	5.32	0.40	1.80	± 13.1 %
5600	35.5	5.07	4.83	4.83	4.83	0.40	1.80	± 13.1 %
5750	35.4	5.22	4.98	4.98	4.98	0.40	1.80	± 13.1 %

^C Frequency validity above 300 MHz of ± 100 MHz only applies for DASY v4.4 and higher (see Page 2), else it is restricted to ± 50 MHz. The uncertainty is the RSS of the ConvF uncertainty at calibration frequency and the uncertainty for the indicated frequency band. Frequency validity below 300 MHz is ± 10, 25, 40, 50 and 70 MHz for ConvF assessments at 30, 64, 128, 150 and 220 MHz respectively. Validity of ConvF assessed at 6 MHz is 4-9 MHz, and ConvF assessed at 13 MHz is 9-19 MHz. Above 5 GHz frequency validity can be extended to ± 110 MHz.

^F At frequencies below 3 GHz, the validity of tissue parameters (ϵ and σ) can be relaxed to ± 10% if liquid compensation formula is applied to measured SAR values. At frequencies above 3 GHz, the validity of tissue parameters (ϵ and σ) is restricted to ± 5%. The uncertainty is the RSS of the ConvF uncertainty for indicated target tissue parameters.

^G Alpha/Depth are determined during calibration. SPEAG warrants that the remaining deviation due to the boundary effect after compensation is always less than ± 1% for frequencies below 3 GHz and below ± 2% for frequencies between 3-6 GHz at any distance larger than half the probe tip diameter from the boundary.

EX3DV4- SN:7543

August 5, 2019

DASY/EASY - Parameters of Probe: EX3DV4 - SN:7543

Calibration Parameter Determined in Body Tissue Simulating Media

f (MHz) ^C	Relative Permittivity ^F	Conductivity (S/m) ^F	ConvF X	ConvF Y	ConvF Z	Alpha ^G	Depth ^G (mm)	Unc (k=2)
750	55.5	0.96	10.25	10.25	10.25	0.45	0.86	± 12.0 %
835	55.2	0.97	9.92	9.92	9.92	0.49	0.83	± 12.0 %
1750	53.4	1.49	8.18	8.18	8.18	0.32	0.86	± 12.0 %
1950	53.3	1.52	7.89	7.89	7.89	0.27	0.80	± 12.0 %
3300	51.6	3.08	6.61	6.61	6.61	0.40	1.30	± 13.1 %
3500	51.3	3.31	6.39	6.39	6.39	0.40	1.30	± 13.1 %
3700	51.0	3.55	6.35	6.35	6.35	0.40	1.30	± 13.1 %
3900	51.2	3.78	5.96	5.96	5.96	0.50	1.60	± 13.1 %
4100	50.5	4.01	5.85	5.85	5.85	0.45	1.60	± 13.1 %
4400	50.1	4.37	5.82	5.82	5.82	0.45	1.70	± 13.1 %
4600	49.8	4.60	5.69	5.69	5.69	0.45	1.80	± 13.1 %
4800	49.6	4.83	5.35	5.35	5.35	0.45	1.80	± 13.1 %
4950	49.4	5.01	4.92	4.92	4.92	0.50	1.90	± 13.1 %
5250	48.9	5.36	4.65	4.65	4.65	0.50	1.90	± 13.1 %
5600	48.5	5.77	4.10	4.10	4.10	0.50	1.90	± 13.1 %
5750	48.3	5.94	4.22	4.22	4.22	0.50	1.90	± 13.1 %

^C Frequency validity above 300 MHz of ± 100 MHz only applies for DASY v4.4 and higher (see Page 2), else it is restricted to ± 50 MHz. The uncertainty is the RSS of the ConvF uncertainty at calibration frequency and the uncertainty for the indicated frequency band. Frequency validity below 300 MHz is ± 10, 25, 40, 50 and 70 MHz for ConvF assessments at 30, 64, 128, 150 and 220 MHz respectively. Validity of ConvF assessed at 6 MHz is 4-9 MHz, and ConvF assessed at 13 MHz is 9-19 MHz. Above 5 GHz frequency validity can be extended to ± 110 MHz.

^F At frequencies below 3 GHz, the validity of tissue parameters (ϵ and σ) can be relaxed to ± 10% if liquid compensation formula is applied to measured SAR values. At frequencies above 3 GHz, the validity of tissue parameters (ϵ and σ) is restricted to ± 5%. The uncertainty is the RSS of the ConvF uncertainty for indicated target tissue parameters.

^G Alpha/Depth are determined during calibration. SPEAG warrants that the remaining deviation due to the boundary effect after compensation is always less than ± 1% for frequencies below 3 GHz and below ± 2% for frequencies between 3-6 GHz at any distance larger than half the probe tip diameter from the boundary.

EX3DV4- SN:7543

August 5, 2019

Frequency Response of E-Field (TEM-Cell:ifi110 EXX, Waveguide: R22)

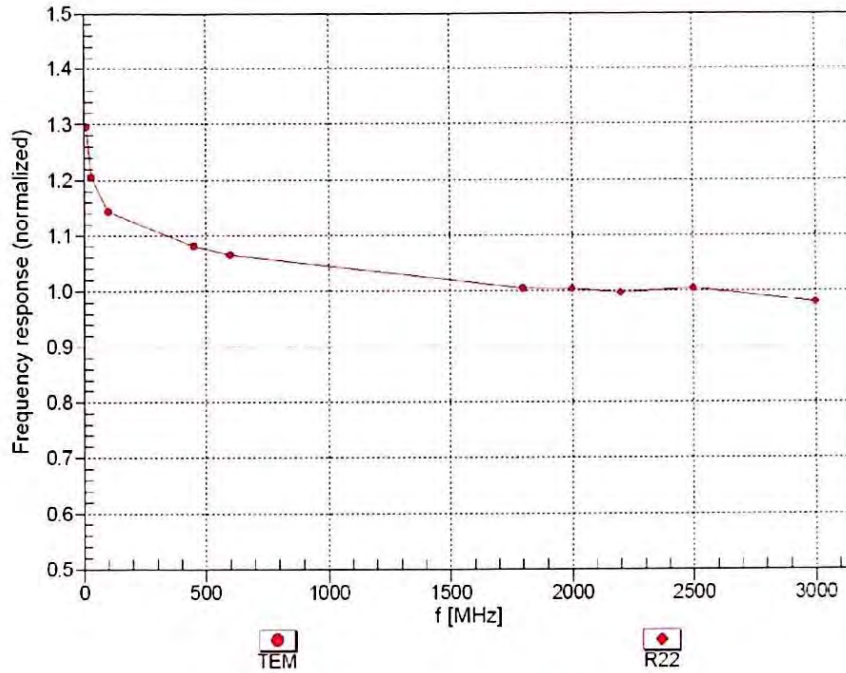

Uncertainty of Frequency Response of E-field: $\pm 6.3\%$ (k=2)

EX3DV4- SN:7543

August 5, 2019

Receiving Pattern (ϕ), $\theta = 0^\circ$

f=600 MHz,TEM

f=1800 MHz,R22

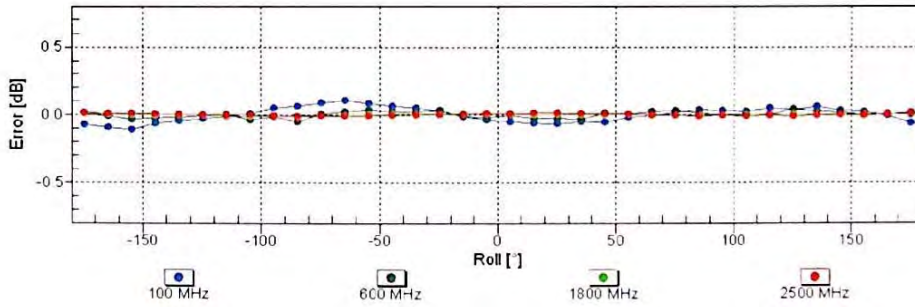
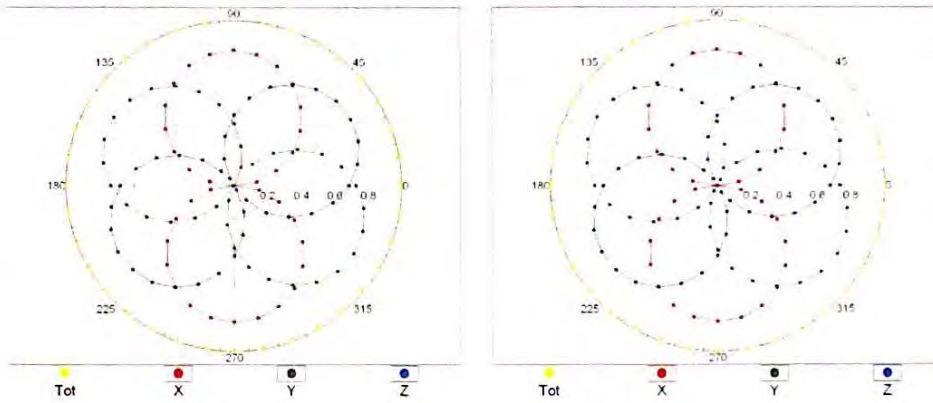

Uncertainty of Axial Isotropy Assessment: $\pm 0.5\%$ (k=2)

EX3DV4- SN.7543

August 5, 2019

Dynamic Range $f(SAR_{head})$ (TEM cell, $f_{eval}=1900$ MHz)

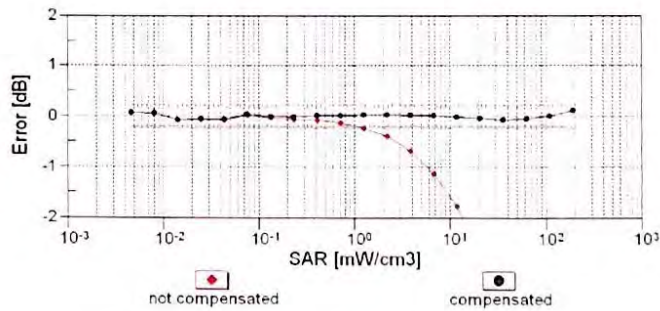
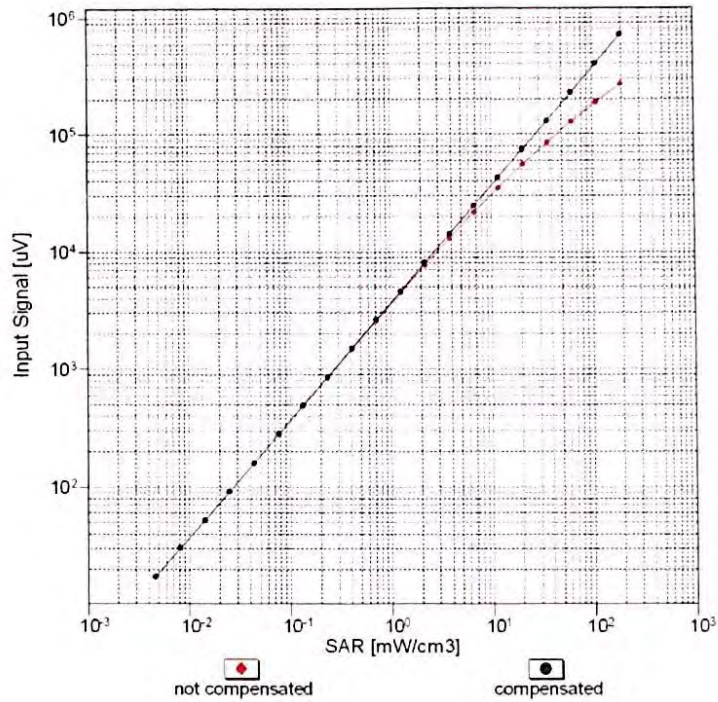

Uncertainty of Linearity Assessment: $\pm 0.6\%$ ($k=2$)

EX3DV4- SN:7543

August 5, 2019

Conversion Factor Assessment

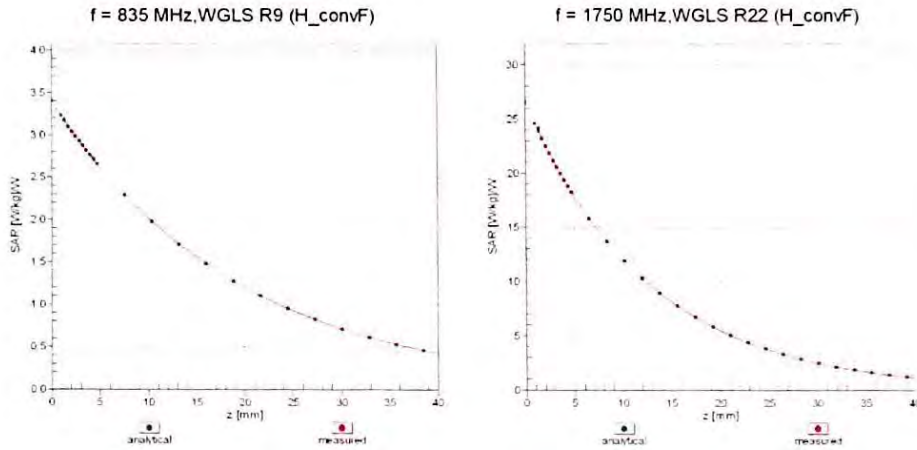

Deviation from Isotropy in Liquid

Error (ϕ, θ), $f = 900$ MHz

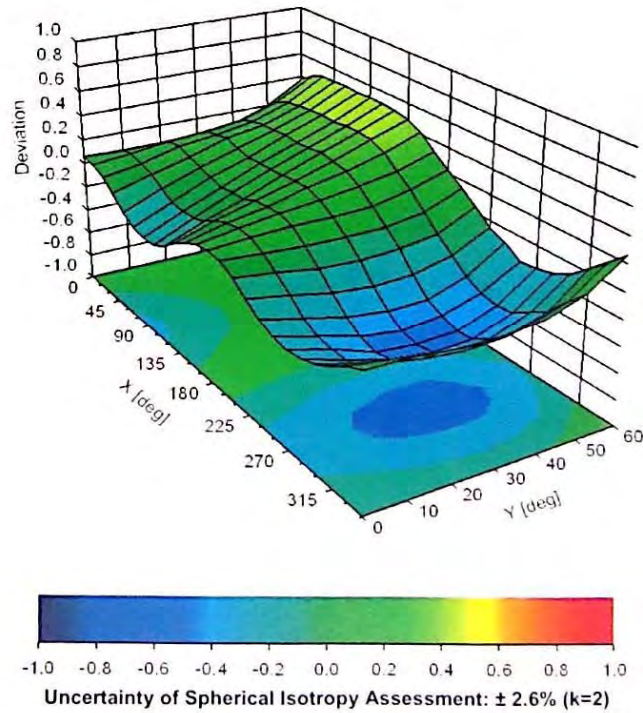



ANNEX F: D2450V2 Dipole Calibration Certificate



In Collaboration with
s p e a g
CALIBRATION LABORATORY



中国认可
国际互认
校准
CALIBRATION
CNAS L0570

Add: No.51 Xueyuan Road, Haidian District, Beijing, 100191, China
Tel: +86-10-62304633-2079 Fax: +86-10-62304633-2504
E-mail: cttl@chinattl.com http://www.chinattl.cn

Client

TA(Shanghai)

Certificate No:

Z17-97116

CALIBRATION CERTIFICATE

Object

D2450V2 - SN: 786

Calibration Procedure(s)

FF-Z11-003-01

Calibration Procedures for dipole validation kits

Calibration date:

August 29, 2017

This calibration Certificate documents the traceability to national standards, which realize the physical units of measurements(SI). The measurements and the uncertainties with confidence probability are given on the following pages and are part of the certificate.

All calibrations have been conducted in the closed laboratory facility: environment temperature(22±3)°C and humidity<70%.

Calibration Equipment used (M&TE critical for calibration)

Primary Standards	ID #	Cal Date(Calibrated by, Certificate No.)	Scheduled Calibration
Power Meter NRVD	102083	22-Sep-16 (CTTL, No.J16X06809)	Sep-17
Power sensor NRV-Z5	100595	22-Sep-16 (CTTL, No.J16X06809)	Sep-17
Reference Probe EX3DV4	SN 3617	23-Jan-17(SPEAG,No.EX3-3617_Jan17)	Jan-18
DAE4	SN 1331	19-Jan-17(CTTL-SPEAG,No.Z17-97015)	Jan-18
Secondary Standards	ID #	Cal Date(Calibrated by, Certificate No.)	Scheduled Calibration
Signal Generator E4438C	MY49071430	13-Jan-17 (CTTL, No.J17X00286)	Jan-18
Network Analyzer E5071C	MY46110673	13-Jan-17 (CTTL, No.J17X00285)	Jan-18

	Name	Function	Signature
Calibrated by:	Zhao Jing	SAR Test Engineer	
Reviewed by:	Lin Hao	SAR Test Engineer	
Approved by:	Qi Dianyuan	SAR Project Leader	

Issued: September 1, 2017

This calibration certificate shall not be reproduced except in full without written approval of the laboratory.

Certificate No: Z17-97116

Page 1 of 8



In Collaboration with
s p e a g
CALIBRATION LABORATORY

Add: No.51 Xueyuan Road, Haidian District, Beijing, 100191, China
Tel: +86-10-62304633-2079 Fax: +86-10-62304633-2504
E-mail: cttl@chinattl.com http://www.chinattl.cn

Glossary:

TSL	tissue simulating liquid
ConvF	sensitivity in TSL / NORM _{x,y,z}
N/A	not applicable or not measured

Calibration is Performed According to the Following Standards:

- IEEE Std 1528-2013, "IEEE Recommended Practice for Determining the Peak Spatial-Averaged Specific Absorption Rate (SAR) in the Human Head from Wireless Communications Devices: Measurement Techniques", June 2013
- IEC 62209-1, "Measurement procedure for assessment of specific absorption rate of human exposure to radio frequency fields from hand-held and body-mounted wireless communication devices- Part 1: Device used next to the ear (Frequency range of 300MHz to 6GHz)", July 2016
- IEC 62209-2, "Procedure to measure the Specific Absorption Rate (SAR) For wireless communication devices used in close proximity to the human body (frequency range of 30MHz to 6GHz)", March 2010
- KDB865664, SAR Measurement Requirements for 100 MHz to 6 GHz

Additional Documentation:

- DASY4/5 System Handbook

Methods Applied and Interpretation of Parameters:

- Measurement Conditions:** Further details are available from the Validation Report at the end of the certificate. All figures stated in the certificate are valid at the frequency indicated.
- Antenna Parameters with TSL:** The dipole is mounted with the spacer to position its feed point exactly below the center marking of the flat phantom section, with the arms oriented parallel to the body axis.
- Feed Point Impedance and Return Loss:** These parameters are measured with the dipole positioned under the liquid filled phantom. The impedance stated is transformed from the measurement at the SMA connector to the feed point. The Return Loss ensures low reflected power. No uncertainty required.
- Electrical Delay:** One-way delay between the SMA connector and the antenna feed point. No uncertainty required.
- SAR measured:** SAR measured at the stated antenna input power.
- SAR normalized:** SAR as measured, normalized to an input power of 1 W at the antenna connector.
- SAR for nominal TSL parameters:** The measured TSL parameters are used to calculate the nominal SAR result.

The reported uncertainty of measurement is stated as the standard uncertainty of Measurement multiplied by the coverage factor $k=2$, which for a normal distribution Corresponds to a coverage probability of approximately 95%.



In Collaboration with
s p e a g
CALIBRATION LABORATORY

Add: No.51 Xucyuan Road, Haidian District, Beijing, 100191, China
Tel: +86-10-62304633-2079 Fax: +86-10-62304633-2504
E-mail: cttl@chinattl.com http://www.chinattl.cn

Measurement Conditions

DASY system configuration, as far as not given on page 1.

DASY Version	DASY52	52.10.0.1446
Extrapolation	Advanced Extrapolation	
Phantom	Triple Flat Phantom 5.1C	
Distance Dipole Center - TSL	10 mm	with Spacer
Zoom Scan Resolution	dx, dy, dz = 5 mm	
Frequency	2450 MHz ± 1 MHz	

Head TSL parameters

The following parameters and calculations were applied.

	Temperature	Permittivity	Conductivity
Nominal Head TSL parameters	22.0 °C	39.2	1.80 mho/m
Measured Head TSL parameters	(22.0 ± 0.2) °C	39.7 ± 6 %	1.82 mho/m ± 6 %
Head TSL temperature change during test	<1.0 °C	---	---

SAR result with Head TSL

SAR averaged over 1 cm ³ (1 g) of Head TSL	Condition	
SAR measured	250 mW input power	13.2 mW / g
SAR for nominal Head TSL parameters	normalized to 1W	52.6 mW / g ± 18.8 % (k=2)
SAR averaged over 10 cm ³ (10 g) of Head TSL	Condition	
SAR measured	250 mW input power	6.16 mW / g
SAR for nominal Head TSL parameters	normalized to 1W	24.6 mW / g ± 18.7 % (k=2)

Body TSL parameters

The following parameters and calculations were applied.

	Temperature	Permittivity	Conductivity
Nominal Body TSL parameters	22.0 °C	52.7	1.95 mho/m
Measured Body TSL parameters	(22.0 ± 0.2) °C	52.5 ± 6 %	1.94 mho/m ± 6 %
Body TSL temperature change during test	<1.0 °C	---	---

SAR result with Body TSL

SAR averaged over 1 cm ³ (1 g) of Body TSL	Condition	
SAR measured	250 mW input power	12.7 mW / g
SAR for nominal Body TSL parameters	normalized to 1W	50.8 mW / g ± 18.8 % (k=2)
SAR averaged over 10 cm ³ (10 g) of Body TSL	Condition	
SAR measured	250 mW input power	5.87 mW / g
SAR for nominal Body TSL parameters	normalized to 1W	23.5 mW / g ± 18.7 % (k=2)



In Collaboration with
s p e a g
 CALIBRATION LABORATORY

Add: No.51 Xueyuan Road, Haidian District, Beijing, 100191, China
 Tel: +86-10-62304633-2079 Fax: +86-10-62304633-2504
 E-mail: cttl@chinattl.com http://www.chinattl.cn

Appendix (Additional assessments outside the scope of CNAS L0570)

Antenna Parameters with Head TSL

Impedance, transformed to feed point	53.4Ω+ 4.29jΩ
Return Loss	- 25.5dB

Antenna Parameters with Body TSL

Impedance, transformed to feed point	51.0Ω+ 6.61jΩ
Return Loss	- 23.6dB

General Antenna Parameters and Design

Electrical Delay (one direction)	1.265 ns
----------------------------------	----------

After long term use with 100W radiated power, only a slight warming of the dipole near the feedpoint can be measured.

The dipole is made of standard semirigid coaxial cable. The center conductor of the feeding line is directly connected to the second arm of the dipole. The antenna is therefore short-circuited for DC-signals. On some of the dipoles, small end caps are added to the dipole arms in order to improve matching when loaded according to the position as explained in the "Measurement Conditions" paragraph. The SAR data are not affected by this change. The overall dipole length is still according to the Standard. No excessive force must be applied to the dipole arms, because they might bend or the soldered connections near the feedpoint may be damaged.

Additional EUT Data

Manufactured by	SPEAG
-----------------	-------



In Collaboration with
s p e a g
 CALIBRATION LABORATORY

Add: No.51 Xueyuan Road, Haidian District, Beijing, 100191, China
 Tel: +86-10-62304633-2079 Fax: +86-10-62304633-2504
 E-mail: cttl@chinattl.com http://www.chinattl.cn

DASY5 Validation Report for Head TSL

Date: 08.29.2017

Test Laboratory: CTTL, Beijing, China

DUT: Dipole 2450 MHz; Type: D2450V2; Serial: D2450V2 - SN: 786

Communication System: UID 0, CW; Frequency: 2450 MHz; Duty Cycle: 1:1

Medium parameters used: $f = 2450$ MHz; $\sigma = 1.822$ S/m; $\epsilon_r = 39.65$; $\rho = 1000$ kg/m³

Phantom section: Left Section

Measurement Standard: DASY5 (IEEE/IEC/ANSI C63.19-2007)

DASY5 Configuration:

- Probe: EX3DV4 - SN3617; ConvF(7.74, 7.74, 7.74); Calibrated: 1/23/2017;
- Sensor-Surface: 1.4mm (Mechanical Surface Detection)
- Electronics: DAE4 Sn1331; Calibrated: 1/19/2017
- Phantom: Triple Flat Phantom 5.1C; Type: QD 000 P51 CA; Serial: 1161/1
- Measurement SW: DASY52, Version 52.10 (0); SEMCAD X Version 14.6.10 (7417)

Dipole Calibration/Zoom Scan (7x7x7) (7x7x7)/Cube 0: Measurement grid: dx=5mm, dy=5mm, dz=5mm

Reference Value = 105.1 V/m; Power Drift = -0.03 dB

Peak SAR (extrapolated) = 27.5 W/kg

SAR(1 g) = 13.2 W/kg; SAR(10 g) = 6.16 W/kg

Maximum value of SAR (measured) = 22.2 W/kg

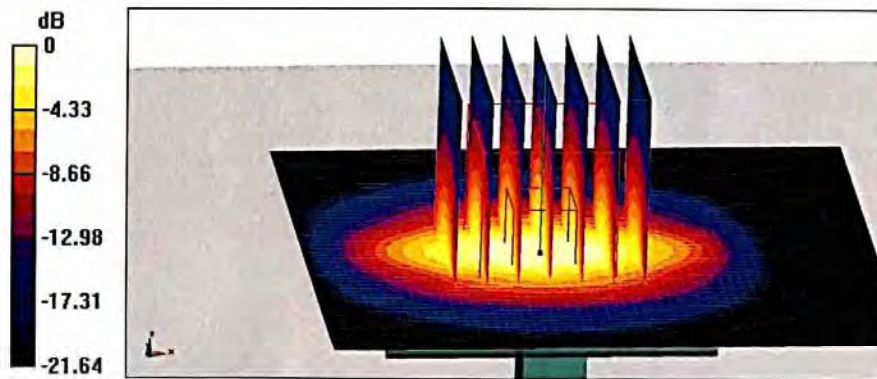

0 dB = 22.2 W/kg = 13.46 dBW/kg



In Collaboration with
s p e a g
CALIBRATION LABORATORY

Add: No.51 Xueyuan Road, Haidian District, Beijing, 100191, China
Tel: +86-10-62304633-2079 Fax: +86-10-62304633-2504
E-mail: cttl@chinattl.com http://www.chinattl.cn

Impedance Measurement Plot for Head TSL

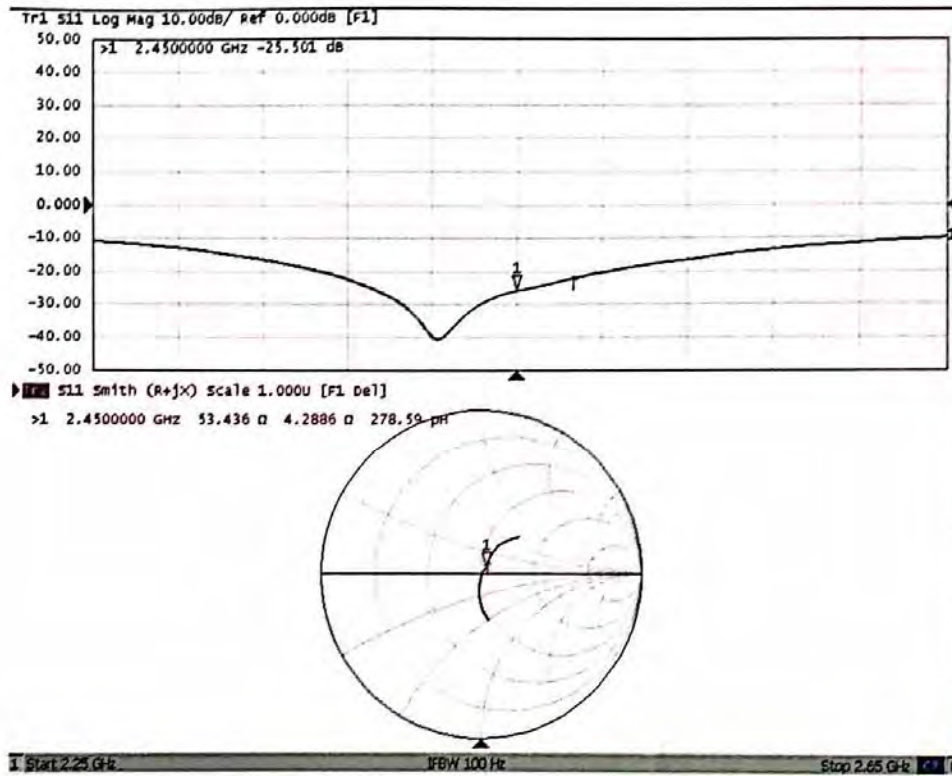



In Collaboration with
s p e a g
CALIBRATION LABORATORY

Add: No.51 Xueyuan Road, Haidian District, Beijing, 100191, China
Tel: +86-10-62304633-2079 Fax: +86-10-62304633-2504
E-mail: cttl@chinattl.com http://www.chinattl.cn

DASY5 Validation Report for Body TSL

Date: 08.29.2017

Test Laboratory: CTTL, Beijing, China

DUT: Dipole 2450 MHz; Type: D2450V2; Serial: D2450V2 - SN: 786

Communication System: UID 0, CW; Frequency: 2450 MHz; Duty Cycle: 1:1

Medium parameters used: $f = 2450$ MHz; $\sigma = 1.943$ S/m; $\epsilon_r = 52.45$; $\rho = 1000$ kg/m³

Phantom section: Right Section

Measurement Standard: DASY5 (IEEE/IEC/ANSI C63.19-2007)

DASY5 Configuration:

- Probe: EX3DV4 - SN3617; ConvF(7.8, 7.8, 7.8); Calibrated: 1/23/2017;
- Sensor-Surface: 1.4mm (Mechanical Surface Detection)
- Electronics: DAE4 Sn1331; Calibrated: 1/19/2017
- Phantom: Triple Flat Phantom 5.1C; Type: QD 000 P51 CA; Serial: 1161/1
- Measurement SW: DASY52, Version 52.10 (0); SEMCAD X Version 14.6.10 (7417)

Dipole Calibration/Zoom Scan (7x7x7) (7x7x7)/Cube 0: Measurement grid: dx=5mm, dy=5mm, dz=5mm

Reference Value = 92.28 V/m; Power Drift = -0.01 dB

Peak SAR (extrapolated) = 27.0 W/kg

SAR(1 g) = 12.7 W/kg; SAR(10 g) = 5.87 W/kg

Maximum value of SAR (measured) = 21.5 W/kg

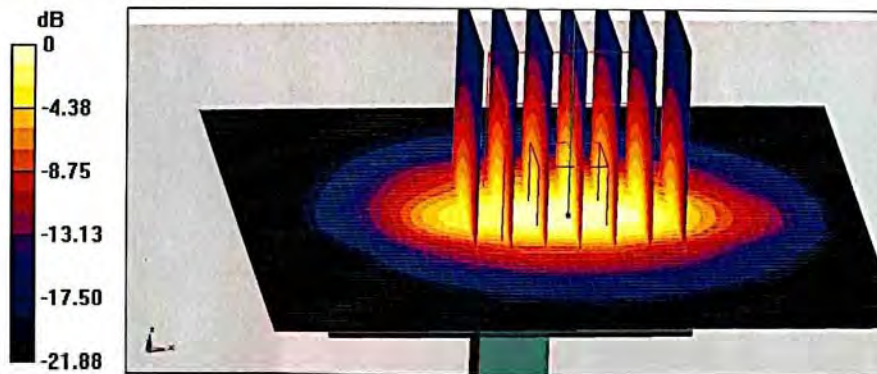

0 dB = 21.5 W/kg = 13.32 dBW/kg



In Collaboration with
s p e a g
CALIBRATION LABORATORY

Add: No.51 Xueyuan Road, Haidian District, Beijing, 100191, China
Tel: +86-10-62304633-2079 Fax: +86-10-62304633-2504
E-mail: cttl@chinattl.com http://www.chinattl.cn

Impedance Measurement Plot for Body TSL

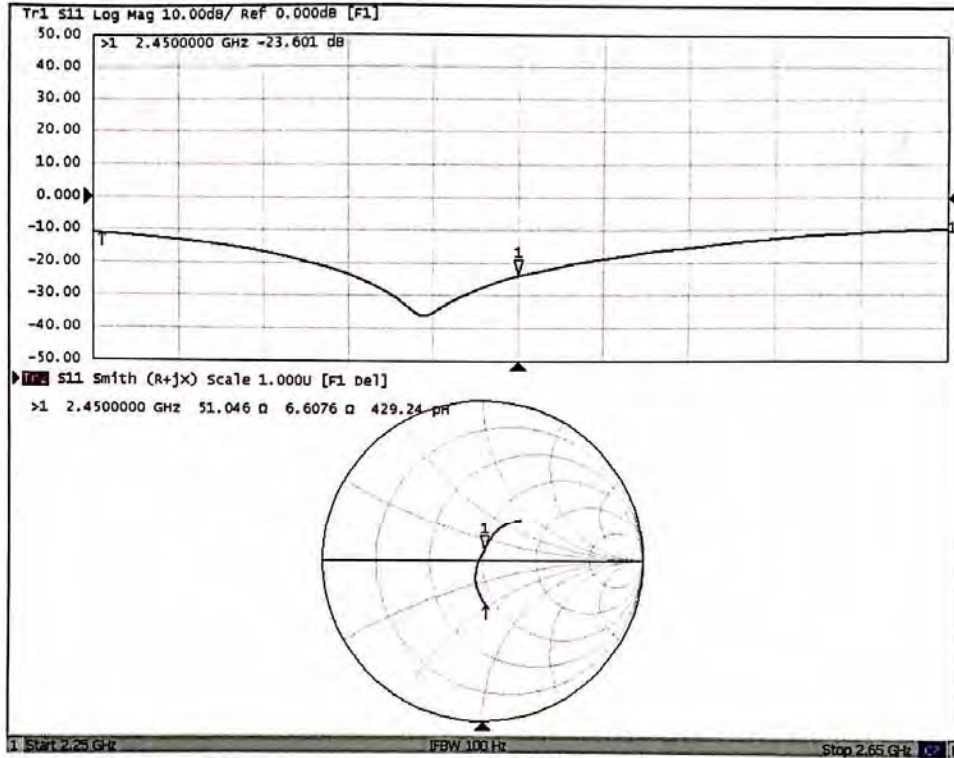



ANNEX G: D2600V2 Dipole Calibration Certificate



In Collaboration with
s p e a g
CALIBRATION LABORATORY



中国认可
国际互认
校准
CALIBRATION
CNAS L0570

Add: No.51 Xueyuan Road, Haidian District, Beijing, 100191, China
Tel: +86-10-62304633-2079 Fax: +86-10-62304633-2504
E-mail: cttl@chinattl.com http://www.chinattl.cn

Client **TA(Shanghai)**Certificate No: **Z18-60094****CALIBRATION CERTIFICATE**

Object **D2600V2 - SN: 1025**

Calibration Procedure(s) **FF-Z11-003-01**
Calibration Procedures for dipole validation kits

Calibration date: **May 2, 2018**

This calibration Certificate documents the traceability to national standards, which realize the physical units of measurements(SI). The measurements and the uncertainties with confidence probability are given on the following pages and are part of the certificate.

All calibrations have been conducted in the closed laboratory facility: environment temperature(22±3)°C and humidity<70%.

Calibration Equipment used (M&TE critical for calibration)

Primary Standards	ID #	Cal Date(Calibrated by, Certificate No.)	Scheduled Calibration
Power Meter NRVD	102083	01-Nov-17 (CTTL, No.J17X08756)	Oct-18
Power sensor NRV-Z5	100542	01-Nov-17 (CTTL, No.J17X08756)	Oct-18
Reference Probe EX3DV4	SN 7464	12-Sep-17(SPEAG, No.EX3-7464_Sep17)	Sep-18
DAE4	SN 1525	02-Oct-17(SPEAG, No.DAE4-1525_Oct17)	Oct-18
Secondary Standards	ID #	Cal Date(Calibrated by, Certificate No.)	Scheduled Calibration
Signal Generator E4438C	MY49071430	23-Jan-18 (CTTL, No.J18X00560)	Jan-19
Network Analyzer E5071C	MY46110673	24-Jan-18 (CTTL, No.J18X00561)	Jan-19

	Name	Function
Calibrated by:	Zhao Jing	SAR Test Engineer
Reviewed by:	Lin Hao	SAR Test Engineer
Approved by:	Qi Dianyuan	SAR Project Leader

Signature

Issued: May 5, 2018

This calibration certificate shall not be reproduced except in full without written approval of the laboratory.

Certificate No: Z18-60094

Page 1 of 8



In Collaboration with
s p e a g
CALIBRATION LABORATORY

Add: No.51 Xueyuan Road, Haidian District, Beijing, 100191, China
Tel: +86-10-62304633-2079 Fax: +86-10-62304633-2504
E-mail: cttl@chinattl.com http://www.chinattl.cn

Glossary:

TSL	tissue simulating liquid
ConvF	sensitivity in TSL / NORM _{x,y,z}
N/A	not applicable or not measured

Calibration Is Performed According to the Following Standards:

- IEEE Std 1528-2013, "IEEE Recommended Practice for Determining the Peak Spatial-Averaged Specific Absorption Rate (SAR) in the Human Head from Wireless Communications Devices: Measurement Techniques", June 2013
- IEC 62209-1, "Measurement procedure for assessment of specific absorption rate of human exposure to radio frequency fields from hand-held and body-mounted wireless communication devices- Part 1: Device used next to the ear (Frequency range of 300MHz to 6GHz)", July 2016
- IEC 62209-2, "Procedure to measure the Specific Absorption Rate (SAR) For wireless communication devices used in close proximity to the human body (frequency range of 30MHz to 6GHz)", March 2010
- KDB865664, SAR Measurement Requirements for 100 MHz to 6 GHz

Additional Documentation:

- DASY4/5 System Handbook

Methods Applied and Interpretation of Parameters:

- Measurement Conditions:** Further details are available from the Validation Report at the end of the certificate. All figures stated in the certificate are valid at the frequency indicated.
- Antenna Parameters with TSL:** The dipole is mounted with the spacer to position its feed point exactly below the center marking of the flat phantom section, with the arms oriented parallel to the body axis.
- Feed Point Impedance and Return Loss:** These parameters are measured with the dipole positioned under the liquid filled phantom. The impedance stated is transformed from the measurement at the SMA connector to the feed point. The Return Loss ensures low reflected power. No uncertainty required.
- Electrical Delay:** One-way delay between the SMA connector and the antenna feed point. No uncertainty required.
- SAR measured:** SAR measured at the stated antenna input power.
- SAR normalized:** SAR as measured, normalized to an input power of 1 W at the antenna connector.
- SAR for nominal TSL parameters:** The measured TSL parameters are used to calculate the nominal SAR result.

The reported uncertainty of measurement is stated as the standard uncertainty of Measurement multiplied by the coverage factor $k=2$, which for a normal distribution Corresponds to a coverage probability of approximately 95%.



In Collaboration with
s p e a g
CALIBRATION LABORATORY

Add: No.51 Xueyuan Road, Haidian District, Beijing, 100191, China
Tel: +86-10-62304633-2079 Fax: +86-10-62304633-2504
E-mail: cttl@chinattl.com http://www.chinattl.cn

Measurement Conditions

DASY system configuration, as far as not given on page 1.

DASY Version	DASY52	52.10.0.1446
Extrapolation	Advanced Extrapolation	
Phantom	Triple Flat Phantom 5.1C	
Distance Dipole Center - TSL	10 mm	with Spacer
Zoom Scan Resolution	dx, dy, dz = 5 mm	
Frequency	2600 MHz ± 1 MHz	

Head TSL parameters

The following parameters and calculations were applied

	Temperature	Permittivity	Conductivity
Nominal Head TSL parameters	22.0 °C	39.0	1.96 mho/m
Measured Head TSL parameters	(22.0 ± 0.2) °C	40.1 ± 6 %	2.01 mho/m ± 6 %
Head TSL temperature change during test	<1.0 °C	—	—

SAR result with Head TSL

SAR averaged over 1 cm ³ (1 g) of Head TSL	Condition	
SAR measured	250 mW input power	13.6 mW / g
SAR for nominal Head TSL parameters	normalized to 1W	54.1 mW / g ± 18.8 % (k=2)
SAR averaged over 10 cm ³ (10 g) of Head TSL	Condition	
SAR measured	250 mW input power	6.03 mW / g
SAR for nominal Head TSL parameters	normalized to 1W	24.1 mW / g ± 18.7 % (k=2)

Body TSL parameters

The following parameters and calculations were applied.

	Temperature	Permittivity	Conductivity
Nominal Body TSL parameters	22.0 °C	52.5	2.16 mho/m
Measured Body TSL parameters	(22.0 ± 0.2) °C	52.1 ± 6 %	2.15 mho/m ± 6 %
Body TSL temperature change during test	<1.0 °C	—	—

SAR result with Body TSL

SAR averaged over 1 cm ³ (1 g) of Body TSL	Condition	
SAR measured	250 mW input power	13.6 mW / g
SAR for nominal Body TSL parameters	normalized to 1W	54.5 mW / g ± 18.8 % (k=2)
SAR averaged over 10 cm ³ (10 g) of Body TSL	Condition	
SAR measured	250 mW input power	6.06 mW / g
SAR for nominal Body TSL parameters	normalized to 1W	24.3 mW / g ± 18.7 % (k=2)



In Collaboration with
s p e a g
 CALIBRATION LABORATORY

Add: No.51 Xueyuan Road, Haidian District, Beijing, 100191, China
 Tel: +86-10-62304633-2079 Fax: +86-10-62304633-2504
 E-mail: ttl@chinattl.com http://www.chinattl.cn

Appendix(Additional assessments outside the scope of CNAS L0570)

Antenna Parameters with Head TSL

Impedance, transformed to feed point	48.1Ω- 7.55jΩ
Return Loss	- 22.0dB

Antenna Parameters with Body TSL

Impedance, transformed to feed point	46.6Ω- 7.06jΩ
Return Loss	- 21.9dB

General Antenna Parameters and Design

Electrical Delay (one direction)	1,014 ns
----------------------------------	----------

After long term use with 100W radiated power, only a slight warming of the dipole near the feedpoint can be measured.

The dipole is made of standard semirigid coaxial cable. The center conductor of the feeding line is directly connected to the second arm of the dipole. The antenna is therefore short-circuited for DC-signals. On some of the dipoles, small end caps are added to the dipole arms in order to improve matching when loaded according to the position as explained in the "Measurement Conditions" paragraph. The SAR data are not affected by this change. The overall dipole length is still according to the Standard. No excessive force must be applied to the dipole arms, because they might bend or the soldered connections near the feedpoint may be damaged.

Additional EUT Data

Manufactured by	SPEAG
-----------------	-------



In Collaboration with
s p e a g
CALIBRATION LABORATORY

Add: No.51 Xueyuan Road, Haidian District, Beijing, 100191, China
Tel: +86-10-62304633-2079 Fax: +86-10-62304633-2504
E-mail: ct11@chinattl.com http://www.chinattl.cn

DASY5 Validation Report for Head TSL

Date: 05.02.2018

Test Laboratory: CTTL, Beijing, China

DUT: Dipole 2600 MHz; Type: D2600V2; Serial: D2600V2 - SN: 1025

Communication System: UID 0, CW; Frequency: 2600 MHz; Duty Cycle: 1:1

Medium parameters used: $f = 2600$ MHz; $\sigma = 2.014$ S/m; $\epsilon_r = 40.09$; $\rho = 1000$ kg/m³

Phantom section: Flat Section

Measurement Standard: DASY5 (IEEE/IEC/ANSI C63.19-2007)

DASY5 Configuration:

- Probe: EX3DV4 - SN7464; ConvF(7.76, 7.76, 7.76); Calibrated: 9/12/2017;
- Sensor-Surface: 1.4mm (Mechanical Surface Detection)
- Electronics: DAE4 Sn1525; Calibrated: 10/2/2017
- Phantom: Triple Flat Phantom 5.1C; Type: QD 000 P51 CA; Serial: 1161/1
- Measurement SW: DASY52, Version 52.10 (0); SEMCAD X Version 14.6.10 (7417)

Dipole Calibration/Zoom Scan (7x7x7) (7x7x7)/Cube 0; Measurement grid: dx=5mm,

dy=5mm, dz=5mm

Reference Value = 98.50 V/m; Power Drift = 0.00 dB

Peak SAR (extrapolated) = 29.6 W/kg

SAR(1 g) = 13.6 W/kg; SAR(10 g) = 6.03 W/kg

Maximum value of SAR (measured) = 23.5 W/kg



0 dB = 23.5 W/kg = 13.71 dBW/kg



In Collaboration with
s p e a g
CALIBRATION LABORATORY

Add: No.51 Xueyuan Road, Haidian District, Beijing, 100191, China
Tel: +86-10-62304633-2079 Fax: +86-10-62304633-2504
E-mail: ettl@chinattl.com <http://www.chinattl.cn>

Impedance Measurement Plot for Head TSL

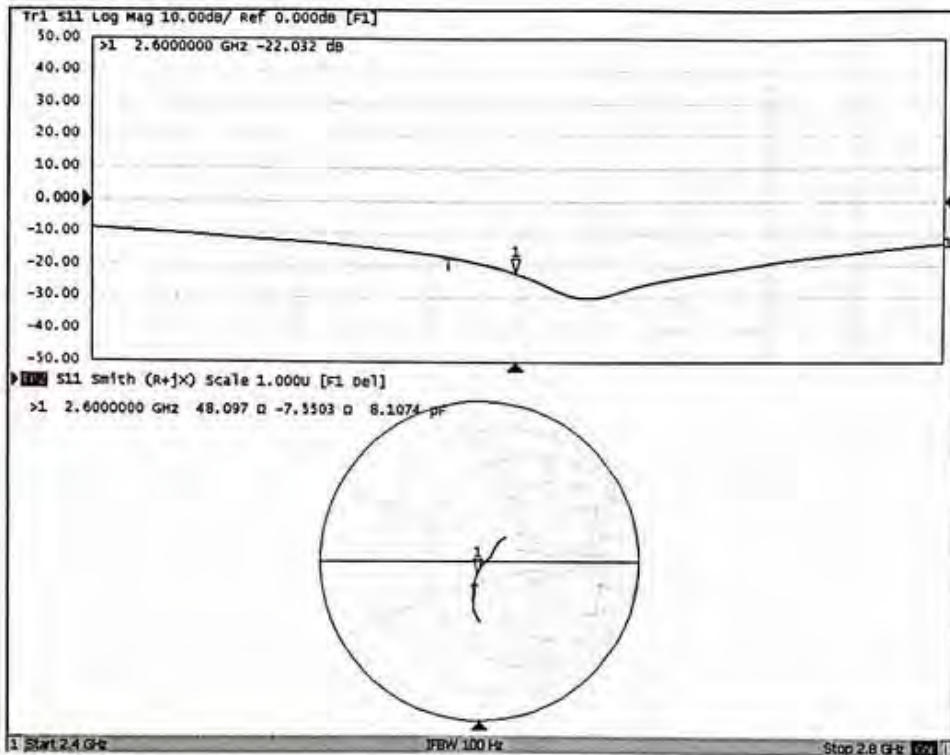



In Collaboration with
s p e a g
CALIBRATION LABORATORY

Add: No.51 Xueyuan Road, Haidian District, Beijing, 100191, China
Tel: +86-10-62304633-2079 Fax: +86-10-62304633-2504
E-mail: cttl@chinattl.com http://www.chinattl.cn

DASY5 Validation Report for Body TSL

Date: 05.02.2018

Test Laboratory: CTTL, Beijing, China

DUT: Dipole 2600 MHz; Type: D2600V2; Serial: D2600V2 - SN: 1025

Communication System: UID 0, CW; Frequency: 2600 MHz; Duty Cycle: 1:1

Medium parameters used: $f = 2600$ MHz; $\sigma = 2.146$ S/m; $\epsilon_r = 52.09$; $\rho = 1000$ kg/m³

Phantom section: Right Section

Measurement Standard: DASY5 (IEEE/IEC/ANSI C63.19-2007)

DASY5 Configuration:

- Probe: EX3DV4 - SN7464; ConvF(7.84, 7.84, 7.84); Calibrated: 9/12/2017;
- Sensor-Surface: 1.4mm (Mechanical Surface Detection)
- Electronics: DAE4 Sn1525; Calibrated: 10/2/2017
- Phantom: Triple Flat Phantom 5.1C; Type: QD 000 P51 CA; Serial: 1161/1
- Measurement SW: DASY52, Version 52.10 (0); SEMCAD X Version 14.6.10 (7417)

Dipole Calibration/Zoom Scan (7x7x7) (7x7x7)/Cube 0: Measurement grid: dx=5mm, dy=5mm, dz=5mm

Reference Value = 83.79 V/m; Power Drift = 0.02 dB

Peak SAR (extrapolated) = 29.7 W/kg

SAR(1 g) = 13.6 W/kg; SAR(10 g) = 6.06 W/kg

Maximum value of SAR (measured) = 23.6 W/kg



0 dB = 23.6 W/kg = 13.73 dBW/kg



In Collaboration with
s p e a g
CALIBRATION LABORATORY

Add: No.51 Xueyuan Road, Haidian District, Beijing, 100191, China
Tel: +86-10-62304633-2079 Fax: +86-10-62304633-2504
E-mail: cttl@chinattl.com http://www.chinattl.cn

Impedance Measurement Plot for Body TSL

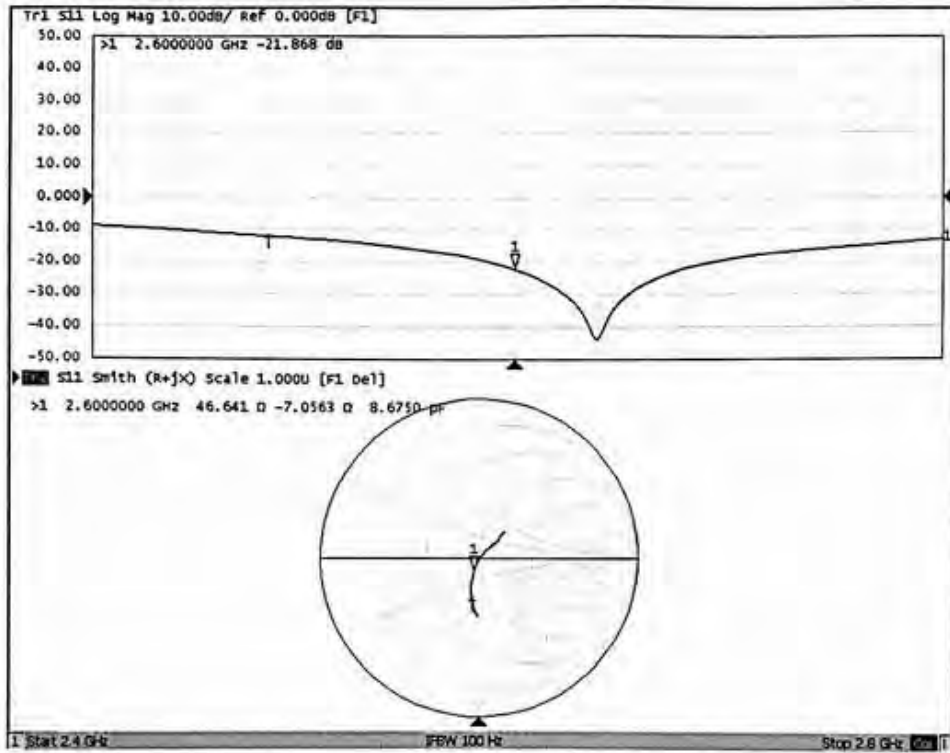

ANNEX H: D3700V2 Dipole Calibration Certificate

**Calibration Laboratory of
Schmid & Partner
Engineering AG**
Zeughausstrasse 43, 8004 Zurich, Switzerland



S Schweizerischer Kalibrierdienst
C Service suisse d'étalonnage
S Servizio svizzero di taratura
S Swiss Calibration Service

Accredited by the Swiss Accreditation Service (SAS)
The Swiss Accreditation Service is one of the signatories to the EA
Multilateral Agreement for the recognition of calibration certificates

Accreditation No.: **SCS 0108**

Client **TA-SH (Auden)**

Certificate No: **D3700V2-1048_Sep19**

CALIBRATION CERTIFICATE

Object: **D3700V2 - SN:1048**

Calibration procedure(s): **QA CAL-22.v4
Calibration Procedure for SAR Validation Sources between 3-6 GHz**

Calibration date: **September 20, 2019**

This calibration certificate documents the traceability to national standards, which realize the physical units of measurements (SI).
The measurements and the uncertainties with confidence probability are given on the following pages and are part of the certificate.

All calibrations have been conducted in the closed laboratory facility: environment temperature (22 ± 3)°C and humidity < 70%.

Calibration Equipment used (M&TE critical for calibration)

Primary Standards	ID #	Cal Date (Certificate No.)	Scheduled Calibration
Power meter NRP	SN: 104778	03-Apr-19 (No. 217-02892/02893)	Apr-20
Power sensor NRP-Z91	SN: 103244	03-Apr-19 (No. 217-02892)	Apr-20
Power sensor NRP-Z91	SN: 103245	03-Apr-19 (No. 217-02893)	Apr-20
Reference 20 dB Attenuator	SN: 5058 (20k)	04-Apr-19 (No. 217-02894)	Apr-20
Type-N mismatch combination	SN: 5047.2 / 06327	04-Apr-19 (No. 217-02895)	Apr-20
Reference Probe EX3DV4	SN: 3503	25-Mar-19 (No. EX3-3503_Mar19)	Mar-20
DAE4	SN: 601	30-Apr-19 (No. DAE4-601_Apr19)	Apr-20
Secondary Standards	ID #	Check Date (in house)	Scheduled Check
Power meter E4419B	SN: GB39512475	30-Oct-14 (in house check Feb-19)	In house check: Oct-20
Power sensor HP 8481A	SN: US37292783	07-Oct-15 (in house check Oct-18)	In house check: Oct-20
Power sensor HP 8481A	SN: MY41092317	07-Oct-15 (in house check Oct-18)	In house check: Oct-20
RF generator R&S SMT-06	SN: 100972	15-Jun-15 (in house check Oct-18)	In house check: Oct-20
Network Analyzer Agilent E8358A	SN: US41080477	31-Mar-14 (in house check Oct-18)	In house check: Oct-19

Calibrated by:	Name Jeton Kastrati	Function Laboratory Technician	Signature
Approved by:	Name Katja Pokovic	Technical Manager	

Issued: September 24, 2019

This calibration certificate shall not be reproduced except in full without written approval of the laboratory.

**Calibration Laboratory of
Schmid & Partner
Engineering AG**
Zeughausstrasse 43, 8004 Zurich, Switzerland



S Schweizerischer Kalibrierdienst
C Service suisse d'étalonnage
S Servizio svizzero di taratura
S Swiss Calibration Service

Accredited by the Swiss Accreditation Service (SAS)
The Swiss Accreditation Service is one of the signatories to the EA
Multilateral Agreement for the recognition of calibration certificates

Accreditation No.: **SCS 0108**

Glossary:

TSL	tissue simulating liquid
ConvF	sensitivity in TSL / NORM x,y,z
N/A	not applicable or not measured

Calibration is Performed According to the Following Standards:

- IEEE Std 1528-2013, "IEEE Recommended Practice for Determining the Peak Spatial-Averaged Specific Absorption Rate (SAR) in the Human Head from Wireless Communications Devices: Measurement Techniques", June 2013
- IEC 62209-1, "Measurement procedure for the assessment of Specific Absorption Rate (SAR) from hand-held and body-mounted devices used next to the ear (frequency range of 300 MHz to 6 GHz)", July 2016
- IEC 62209-2, "Procedure to determine the Specific Absorption Rate (SAR) for wireless communication devices used in close proximity to the human body (frequency range of 30 MHz to 6 GHz)", March 2010
- KDB 865664, "SAR Measurement Requirements for 100 MHz to 6 GHz"

Additional Documentation:

- DASY4/5 System Handbook

Methods Applied and Interpretation of Parameters:

- Measurement Conditions:** Further details are available from the Validation Report at the end of the certificate. All figures stated in the certificate are valid at the frequency indicated.
- Antenna Parameters with TSL:** The dipole is mounted with the spacer to position its feed point exactly below the center marking of the flat phantom section, with the arms oriented parallel to the body axis.
- Feed Point Impedance and Return Loss:** These parameters are measured with the dipole positioned under the liquid filled phantom. The impedance stated is transformed from the measurement at the SMA connector to the feed point. The Return Loss ensures low reflected power. No uncertainty required.
- Electrical Delay:** One-way delay between the SMA connector and the antenna feed point. No uncertainty required.
- SAR measured:** SAR measured at the stated antenna input power.
- SAR normalized:** SAR as measured, normalized to an input power of 1 W at the antenna connector.
- SAR for nominal TSL parameters:** The measured TSL parameters are used to calculate the nominal SAR result.

The reported uncertainty of measurement is stated as the standard uncertainty of measurement multiplied by the coverage factor $k=2$, which for a normal distribution corresponds to a coverage probability of approximately 95%.

Measurement Conditions

DASY system configuration, as far as not given on page 1.

DASY Version	DASY5	V52.10.2
Extrapolation	Advanced Extrapolation	
Phantom	Modular Flat Phantom	
Distance Dipole Center - TSL	10 mm	with Spacer
Zoom Scan Resolution	dx, dy = 4 mm, dz = 1.4 mm	Graded Ratio = 1.4 (Z direction)
Frequency	3700 MHz ± 1 MHz	

Head TSL parameters

The following parameters and calculations were applied.

	Temperature	Permittivity	Conductivity
Nominal Head TSL parameters	22.0 °C	37.7	3.12 mho/m
Measured Head TSL parameters	(22.0 ± 0.2) °C	37.3 ± 6 %	3.07 mho/m ± 6 %
Head TSL temperature change during test	< 0.5 °C	----	----

SAR result with Head TSL

SAR averaged over 1 cm ³ (1 g) of Head TSL	Condition	
SAR measured	100 mW input power	6.71 W/kg
SAR for nominal Head TSL parameters	normalized to 1W	67.2 W/kg ± 19.9 % (k=2)

SAR averaged over 10 cm ³ (10 g) of Head TSL	condition	
SAR measured	100 mW input power	2.44 W/kg
SAR for nominal Head TSL parameters	normalized to 1W	24.4 W/kg ± 19.5 % (k=2)

Body TSL parameters

The following parameters and calculations were applied.

	Temperature	Permittivity	Conductivity
Nominal Body TSL parameters	22.0 °C	51.0	3.55 mho/m
Measured Body TSL parameters	(22.0 ± 0.2) °C	49.5 ± 6 %	3.55 mho/m ± 6 %
Body TSL temperature change during test	< 0.5 °C	----	----

SAR result with Body TSL

SAR averaged over 1 cm ³ (1 g) of Body TSL	Condition	
SAR measured	100 mW input power	6.53 W/kg
SAR for nominal Body TSL parameters	normalized to 1W	64.8 W/kg ± 19.9 % (k=2)

SAR averaged over 10 cm ³ (10 g) of Body TSL	condition	
SAR measured	100 mW input power	2.33 W/kg
SAR for nominal Body TSL parameters	normalized to 1W	23.2 W/kg ± 19.5 % (k=2)

Appendix (Additional assessments outside the scope of SCS 0108)

Antenna Parameters with Head TSL

Impedance, transformed to feed point	44.7 Ω - 2.5 j Ω
Return Loss	- 24.1 dB

Antenna Parameters with Body TSL

Impedance, transformed to feed point	43.9 Ω - 2.0 j Ω
Return Loss	- 23.3 dB

General Antenna Parameters and Design

Electrical Delay (one direction)	1.137 ns
----------------------------------	----------

After long term use with 100W radiated power, only a slight warming of the dipole near the feedpoint can be measured.

The dipole is made of standard semirigid coaxial cable. The center conductor of the feeding line is directly connected to the second arm of the dipole. The antenna is therefore short-circuited for DC-signals. On some of the dipoles, small end caps are added to the dipole arms in order to improve matching when loaded according to the position as explained in the "Measurement Conditions" paragraph. The SAR data are not affected by this change. The overall dipole length is still according to the Standard.

No excessive force must be applied to the dipole arms, because they might bend or the soldered connections near the feedpoint may be damaged.

Additional EUT Data

Manufactured by	SPEAG
-----------------	-------

DASY5 Validation Report for Head TSL

Date: 20.09.2019

Test Laboratory: SPEAG, Zurich, Switzerland

DUT: Dipole 3700 MHz; Type: D3700V2; Serial: D3700V2 - SN:1048

Communication System: UID 0 - CW; Frequency: 3700 MHz

Medium parameters used: $f = 3700$ MHz; $\sigma = 3.07$ S/m; $\epsilon_r = 37.3$; $\rho = 1000$ kg/m³

Phantom section: Flat Section

Measurement Standard: DASY5 (IEEE/IEC/ANSI C63.19-2011)

DASY52 Configuration:

- Probe: EX3DV4 - SN3503; ConvF(7.5, 7.5, 7.5) @ 3700 MHz; Calibrated: 25.03.2019
- Sensor-Surface: 1.4mm (Mechanical Surface Detection)
- Electronics: DAE4 Sn601; Calibrated: 30.04.2019
- Phantom: Flat Phantom 5.0 (front); Type: QD 000 P50 AA; Serial: 1001
- DASY52 52.10.2(1504); SEMCAD X 14.6.12(7470)

Dipole Calibration for Head Tissue/Pin=100 mW, d=10mm, f=3700MHz/Zoom Scan,

dist=1.4mm (8x8x8)/Cube 0: Measurement grid: dx=4mm, dy=4mm, dz=1.4mm

Reference Value = 71.56 V/m; Power Drift = 0.02 dB

Peak SAR (extrapolated) = 19.2 W/kg

SAR(1 g) = 6.71 W/kg; SAR(10 g) = 2.44 W/kg

Maximum value of SAR (measured) = 13.1 W/kg

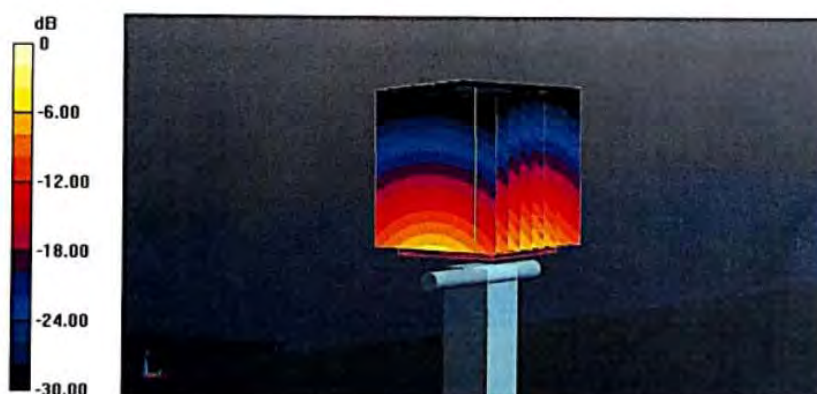

0 dB = 13.1 W/kg = 11.18 dBW/kg



Impedance Measurement Plot for Head TSL

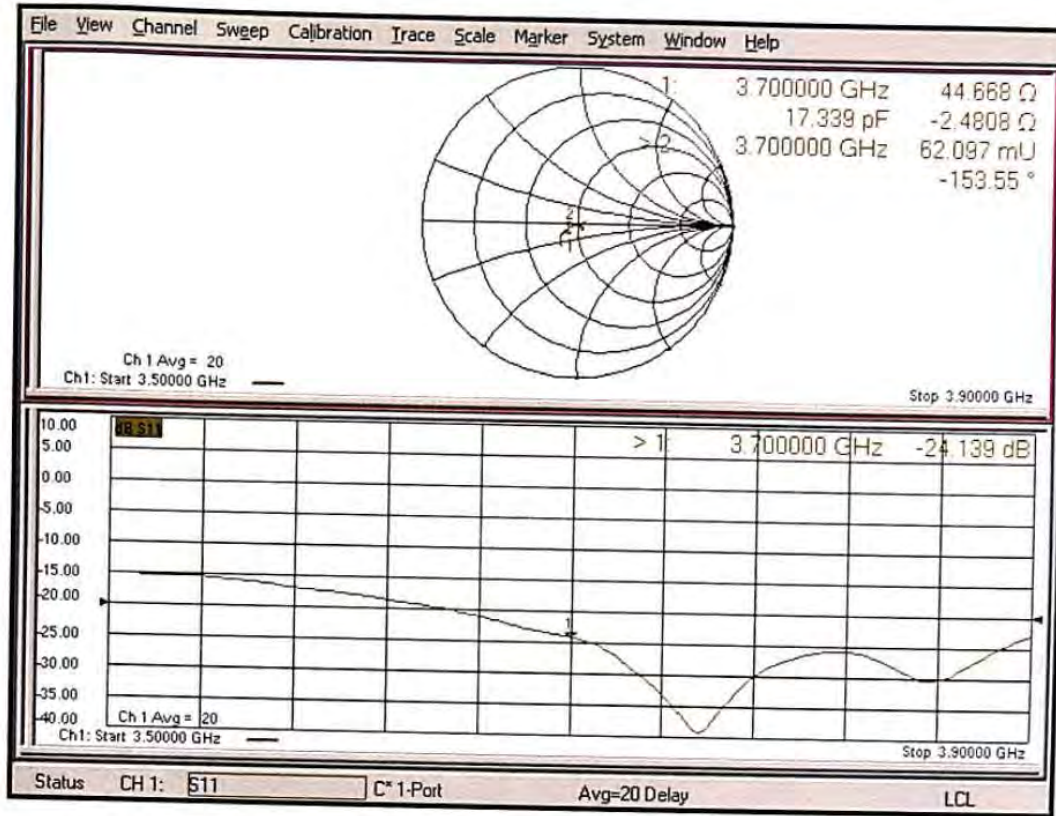

DASY5 Validation Report for Body TSL

Date: 20.09.2019

Test Laboratory: SPEAG, Zurich, Switzerland

DUT: Dipole 3700 MHz; Type: D3700V2; Serial: D3700V2 - SN:1048

Communication System: UID 0 - CW; Frequency: 3700 MHz

Medium parameters used: $f = 3700$ MHz; $\sigma = 3.55$ S/m; $\epsilon_r = 49.5$; $\rho = 1000$ kg/m³

Phantom section: Flat Section

Measurement Standard: DASY5 (IEEE/IEC/ANSI C63.19-2011)

DASY52 Configuration:

- Probe: EX3DV4 - SN3503; ConvF(7.1, 7.1, 7.1) @ 3700 MHz; Calibrated: 25.03.2019
- Sensor-Surface: 1.4mm (Mechanical Surface Detection)
- Electronics: DAE4 Sn601; Calibrated: 30.04.2019
- Phantom: Flat Phantom 5.0 (back); Type: QD 000 P50 AA; Serial: 1002
- DASY52 52.10.2(1504); SEMCAD X 14.6.12(7470)

Dipole Calibration for Body Tissue/Pin=100 mW, d=10mm, f=3700MHz/Zoom Scan , dist=1.4mm (8x8x8)/Cube 0: Measurement grid: dx=4mm, dy=4mm, dz=1.4mm

Reference Value = 65.95 V/m; Power Drift = -0.08 dB

Peak SAR (extrapolated) = 18.0 W/kg

SAR(1 g) = 6.53 W/kg; SAR(10 g) = 2.33 W/kg

Maximum value of SAR (measured) = 12.6 W/kg



0 dB = 12.6 W/kg = 11.02 dBW/kg



Impedance Measurement Plot for Body TSL

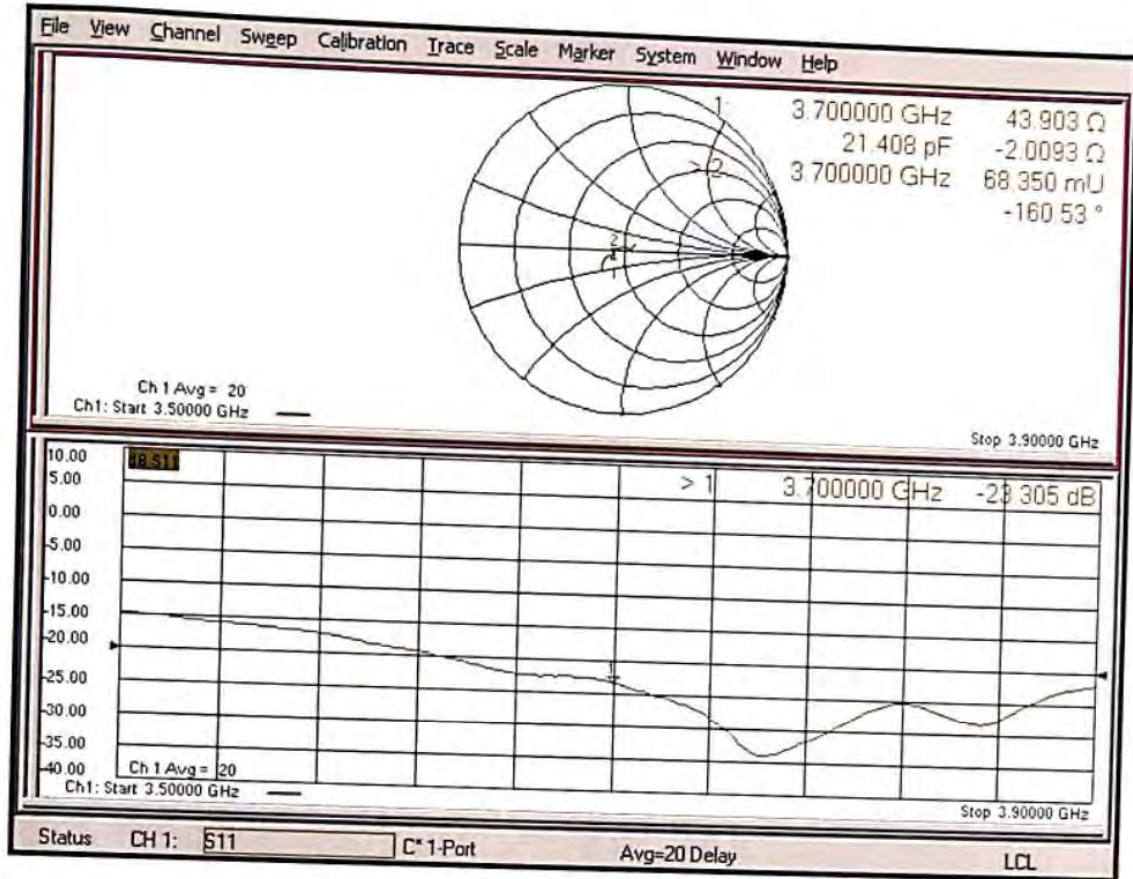

**ANNEX I:DAE4 Calibration Certificate**

**Calibration Laboratory of
Schmid & Partner
Engineering AG**
Zeughausstrasse 43, 8004 Zurich, Switzerland



S Schweizerischer Kalibrierdienst
C Service suisse d'étalonnage
S Servizio svizzero di taratura
S Swiss Calibration Service

Accredited by the Swiss Accreditation Service (SAS)
The Swiss Accreditation Service is one of the signatories to the EA
Multilateral Agreement for the recognition of calibration certificates

Accreditation No.: **SCS 0108**Client **TA-SH (Auden)**Certificate No: **DAE4-1317_Oct19****CALIBRATION CERTIFICATE**

Object	DAE4 - SD 000 D04 BM - SN: 1317		
Calibration procedure(s)	QA CAL-06.v29 Calibration procedure for the data acquisition electronics (DAE)		
Calibration date:	October 23, 2019		
<p>This calibration certificate documents the traceability to national standards, which realize the physical units of measurements (SI). The measurements and the uncertainties with confidence probability are given on the following pages and are part of the certificate.</p> <p>All calibrations have been conducted in the closed laboratory facility: environment temperature (22 ± 3)°C and humidity < 70%.</p> <p>Calibration Equipment used (M&TE critical for calibration)</p>			
Primary Standards	ID #	Cal Date (Certificate No.)	Scheduled Calibration
Keithley Multimeter Type 2001	SN: 0810278	03-Sep-19 (No:25949)	Sep-20
Secondary Standards	ID #	Check Date (in house)	Scheduled Check
Auto DAE Calibration Unit	SE UWS 053 AA 1001	07-Jan-19 (in house check)	In house check: Jan-20
Calibrator Box V2.1	SE UMS 006 AA 1002	07-Jan-19 (in house check)	In house check: Jan-20
Calibrated by:	Name Dominique Steffen	Function Laboratory Technician	Signature
Approved by:	Sven Kühn	Deputy Manager	
			Issued: October 23, 2019
This calibration certificate shall not be reproduced except in full without written approval of the laboratory.			

**Calibration Laboratory of
Schmid & Partner
Engineering AG**
Zeughausstrasse 43, 8004 Zurich, Switzerland



S Schweizerischer Kalibrierdienst
C Service suisse d'étalonnage
S Servizio svizzero di taratura
S Swiss Calibration Service

Accredited by the Swiss Accreditation Service (SAS)
The Swiss Accreditation Service is one of the signatories to the EA
Multilateral Agreement for the recognition of calibration certificates

Accreditation No.: **SCS 0108**

Glossary

DAE data acquisition electronics
Connector angle information used in DASY system to align probe sensor X to the robot coordinate system.

Methods Applied and Interpretation of Parameters

- *DC Voltage Measurement:* Calibration Factor assessed for use in DASY system by comparison with a calibrated instrument traceable to national standards. The figure given corresponds to the full scale range of the voltmeter in the respective range.
- *Connector angle:* The angle of the connector is assessed measuring the angle mechanically by a tool inserted. Uncertainty is not required.
- The following parameters as documented in the Appendix contain technical information as a result from the performance test and require no uncertainty.
 - *DC Voltage Measurement Linearity:* Verification of the Linearity at +10% and -10% of the nominal calibration voltage. Influence of offset voltage is included in this measurement.
 - *Common mode sensitivity:* Influence of a positive or negative common mode voltage on the differential measurement.
 - *Channel separation:* Influence of a voltage on the neighbor channels not subject to an input voltage.
 - *AD Converter Values with inputs shorted:* Values on the internal AD converter corresponding to zero input voltage
 - *Input Offset Measurement:* Output voltage and statistical results over a large number of zero voltage measurements.
 - *Input Offset Current:* Typical value for information; Maximum channel input offset current, not considering the input resistance.
 - *Input resistance:* Typical value for information; DAE input resistance at the connector, during internal auto-zeroing and during measurement.
 - *Low Battery Alarm Voltage:* Typical value for information. Below this voltage, a battery alarm signal is generated.
 - *Power consumption:* Typical value for information. Supply currents in various operating modes.



DC Voltage Measurement

A/D - Converter Resolution nominal

High Range: 1LSB = 6.1μV , full range = -100...+300 mV
Low Range: 1LSB = 61nV , full range = -1.....+3mV

DASY measurement parameters: Auto Zero Time: 3 sec; Measuring time: 3 sec

Calibration Factors	X	Y	Z
High Range	403.804 ± 0.02% (k=2)	404.568 ± 0.02% (k=2)	403.927 ± 0.02% (k=2)
Low Range	3.97954 ± 1.50% (k=2)	3.99058 ± 1.50% (k=2)	3.96919 ± 1.50% (k=2)

Connector Angle

Connector Angle to be used in DASY system	332.5 ° ± 1 °
---	---------------

Appendix (Additional assessments outside the scope of SCS0108)

1. DC Voltage Linearity

High Range	Reading (μV)	Difference (μV)	Error (%)
Channel X + Input	199993.97	-1.61	-0.00
Channel X + Input	20003.68	1.67	0.01
Channel X - Input	-19999.35	1.95	-0.01
Channel Y + Input	199994.72	-0.94	-0.00
Channel Y + Input	20001.93	-0.03	-0.00
Channel Y - Input	-19999.69	1.70	-0.01
Channel Z + Input	199995.14	-0.83	-0.00
Channel Z + Input	20001.23	-0.62	-0.00
Channel Z - Input	-20001.59	-0.08	0.00

Low Range	Reading (μV)	Difference (μV)	Error (%)
Channel X + Input	2000.92	-0.47	-0.02
Channel X + Input	202.45	0.76	0.37
Channel X - Input	-197.45	0.81	-0.41
Channel Y + Input	2000.30	-0.94	-0.05
Channel Y + Input	201.24	-0.37	-0.18
Channel Y - Input	-198.12	0.14	-0.07
Channel Z + Input	2000.71	-0.42	-0.02
Channel Z + Input	200.46	-1.06	-0.53
Channel Z - Input	-198.55	-0.18	0.09

2. Common mode sensitivity

DASY measurement parameters: Auto Zero Time: 3 sec; Measuring time: 3 sec

	Common mode Input Voltage (mV)	High Range Average Reading (μV)	Low Range Average Reading (μV)
Channel X	200	12.11	9.92
	- 200	-9.05	-11.12
Channel Y	200	11.30	11.37
	- 200	-12.29	-12.77
Channel Z	200	1.70	1.84
	- 200	-3.81	-3.72

3. Channel separation

DASY measurement parameters: Auto Zero Time: 3 sec; Measuring time: 3 sec

	Input Voltage (mV)	Channel X (μV)	Channel Y (μV)	Channel Z (μV)
Channel X	200	-	1.67	-4.44
Channel Y	200	8.45	-	3.12
Channel Z	200	10.32	5.39	-

4. AD-Converter Values with inputs shorted

DASY measurement parameters: Auto Zero Time: 3 sec; Measuring time: 3 sec

	High Range (LSB)	Low Range (LSB)
Channel X	15754	15950
Channel Y	16502	16801
Channel Z	16087	13971

5. Input Offset Measurement

DASY measurement parameters: Auto Zero Time: 3 sec; Measuring time: 3 sec

Input 10MΩ

	Average (μV)	min. Offset (μV)	max. Offset (μV)	Std. Deviation (μV)
Channel X	0.94	-0.24	2.94	0.49
Channel Y	0.26	-1.03	1.33	0.51
Channel Z	-1.40	-2.82	0.02	0.54

6. Input Offset Current

Nominal Input circuitry offset current on all channels: <25fA

7. Input Resistance (Typical values for information)

	Zeroing (kOhm)	Measuring (MOhm)
Channel X	200	200
Channel Y	200	200
Channel Z	200	200

8. Low Battery Alarm Voltage (Typical values for information)

Typical values	Alarm Level (VDC)
Supply (+ Vcc)	+7.9
Supply (- Vcc)	-7.6

9. Power Consumption (Typical values for information)

Typical values	Switched off (mA)	Stand by (mA)	Transmitting (mA)
Supply (+ Vcc)	+0.01	+6	+14
Supply (- Vcc)	-0.01	-8	-9