



# RF TEST REPORT

**Applicant** Shanghai Smawave Technology  
Co., Ltd

**FCC ID** 2AU8HSPH310

**Product** Smart communication terminal

**Brand** Smawave

**Model** SPH310

**Report No.** R2001A0020-R1

**Issue Date** April 22, 2020

TA Technology (Shanghai) Co., Ltd. tested the above equipment in accordance with the requirements in **FCC CFR47 Part 2 (2019)/ FCC CFR47 Part 27C (2019)**. The test results show that the equipment tested is capable of demonstrating compliance with the requirements as documented in this report.

Performed by: Peng Tao

Approved by: Kai Xu

**TA Technology (Shanghai) Co., Ltd.**

No.145, Jintang Rd, Tangzhen Industry Park, Pudong Shanghai, China

TEL: +86-021-50791141/2/3

FAX: +86-021-50791141/2/3-8000



## TABLE OF CONTENT

<b>1</b>	<b>Test Laboratory</b> .....	4
1.1	Notes of the Test Report.....	4
<b>1.2.</b>	<b>Test facility</b> .....	4
1.3	Testing Location.....	4
<b>2</b>	<b>General Description of Equipment under Test</b> .....	5
2.1	Applicant and Manufacturer Information.....	5
2.2	General information.....	5
<b>3</b>	<b>Applied Standards</b> .....	6
<b>4</b>	<b>Test Configuration</b> .....	7
<b>5</b>	<b>Test Case Results</b> .....	8
5.1	RF Power Output and Effective Isotropic Radiated Power.....	8
5.2	Radiates Spurious Emission.....	14
<b>6</b>	<b>Main Test Instruments</b> .....	18



## Summary of Measurement Results

Number	Test Case	Clause in FCC rules	Verdict
1	RF Power Output and Effective Isotropic Radiated Power	2.1046 27.50(h)(2)	PASS
2	Radiates Spurious Emission	2.1053 /27.53(m)	PASS

Date of Testing: February 22, 2020~ March 20, 2020

Note: PASS: The EUT complies with the essential requirements in the standard.

FAIL: The EUT does not comply with the essential requirements in the standard.

All indications of Pass/Fail in this report are opinions expressed by TA Technology (Shanghai) Co., Ltd. based on interpretations and/or observations of test results. Measurement Uncertainties were not taken into account and are published for informational purposes only.

**Conducted items except for RF Power Output and Effective Isotropic Radiated Power please refers to MGM5607A module report(Report No.: R2001A0008-R1V1).**



# 1 Test Laboratory

## 1.1 Notes of the Test Report

This report shall not be reproduced in full or partial, without the written approval of **TA technology (shanghai) co., Ltd.** The results documented in this report apply only to the tested sample, under the conditions and modes of operation as described herein. Measurement Uncertainties were not taken into account and are published for informational purposes only. This report is written to support regulatory compliance of the applicable standards stated above.

## 1.2. Test facility

### **FCC (Designation number: CN1179, Test Firm Registration Number: 446626)**

TA Technology (Shanghai) Co., Ltd. has been listed on the US Federal Communications Commission list of test facilities recognized to perform electromagnetic emissions measurements.

### **A2LA (Certificate Number: 3857.01)**

TA Technology (Shanghai) Co., Ltd. has been listed by American Association for Laboratory Accreditation to perform electromagnetic emission measurement.

## 1.3 Testing Location

Company: TA Technology (Shanghai) Co., Ltd.  
Address: No.145, Jintang Rd, Tangzhen Industry Park, Pudong Shanghai, China  
City: Shanghai  
Post code: 201201  
Country: P. R. China  
Contact: Xu Kai  
Telephone: +86-021-50791141/2/3  
Fax: +86-021-50791141/2/3-8000  
Website: <http://www.ta-shanghai.com>  
E-mail: [xukai@ta-shanghai.com](mailto:xukai@ta-shanghai.com)

## 2 General Description of Equipment under Test

### 2.1 Applicant and Manufacturer Information

<b>Applicant</b>	Shanghai Smawave Technology Co. ,Ltd
<b>Applicant address</b>	3/F, Building 8, 1001 North Qinzhou Road , Xuhui District, Shanghai, China
<b>Manufacturer</b>	Shanghai Smawave Technology Co. ,Ltd
<b>Manufacturer address</b>	3/F, Building 8, 1001 North Qinzhou Road , Xuhui District, Shanghai, China

### 2.2 General information

EUT Description			
Model	SPH310		
IMEI:	863134038082221		
Hardware Version	dt863-mb-v0.4		
Software Version	K608_DT863_SPH310_20200414_V9.0		
Power Supply	Battery/AC adapter		
Antenna Type	External Antenna		
Antenna Gain	1.8dBi		
Test Mode(s)	LTE Band 41;		
Test Modulation	(LTE)QPSK /16QAM/64QAM;		
LTE Category	6		
Maximum E.I.R.P.	LTE Band 41:	24.7dBm	
Rated Power Supply Voltage:	7.4V		
Extreme Voltage	Minimum: 6.8V    Maximum: 8.7V		
Extreme Temperature	Lowest: -40°C    Highest: +70°C		
Operating Frequency Range(s)	Mode	Tx (MHz)	Rx (MHz)
	LTE Band 41	2496 ~ 2690	2496 ~ 2690
Note: 1. The EUT is sent from the applicant to TA and the information of the EUT is declared by the applicant.			



### 3 Applied Standards

According to the specifications of the manufacturer, it must comply with the requirements of the following standards:

**Test standards:**

**FCC CFR47 Part 27C (2019)**

**ANSI C63.26 (2015)**

**Reference standard:**

**FCC CFR47 Part 2 (2019)**

**KDB 971168 D01 Power Meas License Digital Systems v03r01**

## 4 Test Configuration

Radiated measurements are performed by rotating the EUT in three different orthogonal test planes. EUT stand-up position (Z axis), lie-down position (X, Y axis). Receiver antenna polarization (horizontal and vertical), the worst emission was found in position (Z axis, horizontal polarization) and the worst case was recorded.

All mode and data rates and positions and RB size and modulations were investigated. Subsequently, only the worst case emissions are reported.

The following testing in LTE is set based on the maximum RF Output Power.

The following testing in different Bandwidth is set to detail in the following table:

Test modes are chosen to be reported as the worst case configuration below for LTE Band 41:

Test items	Modes	Bandwidth (MHz)						Modulation		RB			Test Channel			
		1.4	3	5	10	15	20	QPSK	16QAM	1	50%	100%	L	M	H	
RF Power Output and Effective Isotropic Radiated Power	LTE 41	-	-	O	O	O	O	O	O	O	O	O	O	O	O	O
Radiates Spurious Emission	LTE 41	-	-	O	-	-	O	O	-	O	-	-	O	O	O	
Note	1. The mark "O" means that this configuration is chosen for testing. 2. The mark "-" means that this configuration is not testing.															

## 5 Test Case Results

### 5.1 RF Power Output and Effective Isotropic Radiated Power

#### Ambient condition

Temperature	Relative humidity	Pressure
23°C ~25°C	45%~50%	101.5kPa

#### Methods of Measurement

During the process of the testing, The EUT is controlled by the Base Station Simulator to ensure max power transmission and proper modulation.

1. The testing follows FCC KDB 971168 D01 v03r01 Section 5.8 and ANSI C63.26 (2015).
  - a) Connect the equipment as illustrated. Mount the equipment with the manufacturer specified antenna in a vertical orientation on a manufacturer specified mounting surface located on a non-conducting rotating platform of a RF anechoic chamber (preferred) or a standard radiation site.
  - b) Key the transmitter, then rotate the EUT 360° azimuthally and record spectrum analyzer power level (LVL) measurements at angular increments that are sufficiently small to permit resolution of all peaks. If a standard radiation test site is used, raise and lower the test antenna to obtain a maximum reading at each angular increment. (Note: several batteries may be needed to offset the effect of battery voltage droop, which should not exceed 5% of the manufactured specified battery voltage during transmission).
  - c) Replace the transmitter under test with a vertically polarized half-wave dipole (or an antenna whose gain is known relative to an ideal half-wave dipole). The center of the antenna should be at the same location as the center of the antenna under test.
  - d) Connect the antenna to a signal generator with a known output power and record the path loss (in dB) as LOSS. If a standard radiation test site is used, raise and lower the test antenna to obtain a maximum reading.  $LOSS = \text{Generator Output Power (dBm)} - \text{Analyzer reading (dBm)}$
  - e) Determine the effective radiated output power at each angular position from the readings in steps b) and d) using the following equation:  $ERP \text{ (dBm)} = \text{LVL (dBm)} + \text{LOSS (dB)}$
  - f) The maximum ERP is the maximum value determined in the preceding step.
  - g) When calculating ERP, in addition to knowing the antenna radiation and matching characteristics, it is necessary to know the loss values of all elements (e.g. transmission line attenuation, mismatches, filters, combiners) interposed between the point where transmitter output power is measured, and the point where power is applied to the antenna. ERP can then be calculated as follows:

$$EIRP \text{ (dBm)} = \text{Output Power (dBm)} - \text{Losses (dB)} + \text{Antenna Gain (dBi)}$$

where: dBd refers to gain relative to an ideal dipole.

$$EIRP \text{ (dBm)} = ERP \text{ (dBm)} + 2.15 \text{ (dB.)}$$

The RB allocation refers to section 5.1, using the maximum output power configuration.



**Test Setup**

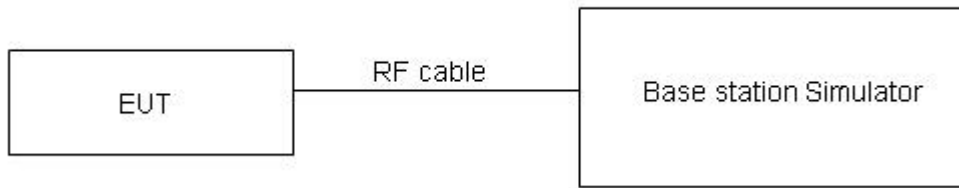

The loss between RF output port of the EUT and the input port of the tester has been taken into consideration.

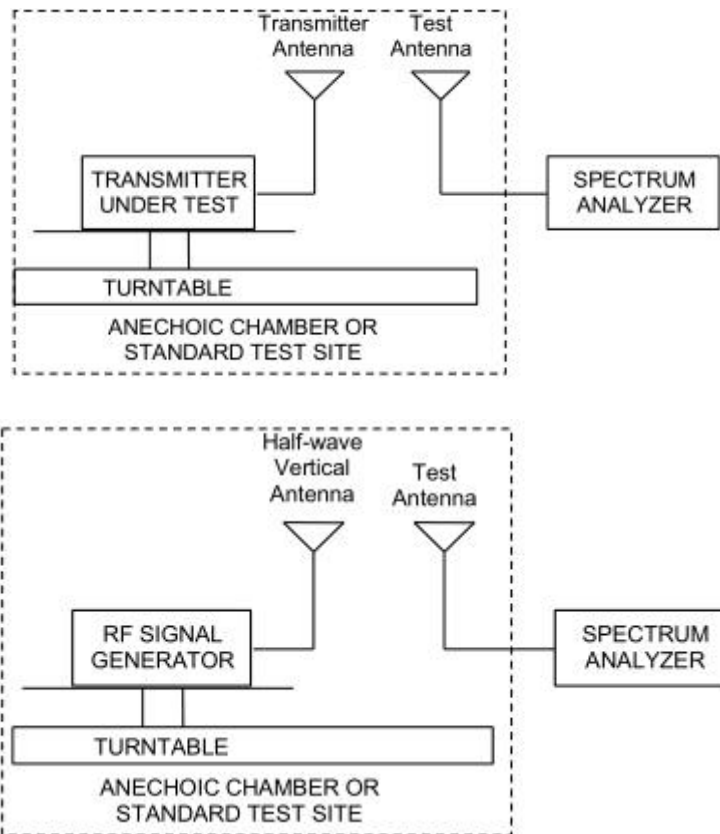

Note: Area side:2.4mX3.6m

The radiated emission was measured in the following position: EUT stand-up position (Z axis), lie-down position (X, Y axis). The worst emission was found in stand-up position (Z axis) and the worst case was recorded.

**Limits**

No specific RF power output requirements in part 2.1046.

Rule Part 27.50(h) (2) specifies that “Mobile and other user stations. Mobile stations are limited to 2.0 watts EIRP. All user stations are limited to 2.0 watts transmitter output power.”

Part 27.50(h)(2) Limit-	≤ 2 W (33 dBm)
-------------------------	----------------



## Measurement Uncertainty

The assessed measurement uncertainty to ensure 95% confidence level for the normal distribution is with the coverage factor  $k = 2$ ,  $U=0.4$  dB for RF power output,  $k = 2$ ,  $U= 1.19$  dB for ERP/EIRP.



Test Results

LTE TDD Band 41				Conducted Power(dBm)					EIRP(dBm)					Verdict
Bandwidth	Modulation	RB allocation	Offset	Channel/Frequency(MHz)					Channel/Frequency(MHz)					
				3967	4014	4062	4109	4156	3967	4014	4062	4109	4156	
				5/	8/	0/	3/	5/	5/	8/	0/	3/	5/	
				2498.5	2545.8	2593	2640.3	2687.5	2498.5	2545.8	2593	2640.3	2687.5	
5MHz	QPSK	1	0	21.78	22.24	21.84	21.78	21.83	23.58	24.04	23.64	23.58	23.63	pass
		1	13	21.65	21.7	21.65	21.37	21.9	23.45	23.5	23.45	23.17	23.7	pass
		1	24	21.7	21.79	22.03	21.39	22.87	23.5	23.59	23.83	23.19	24.67	pass
		12	0	20.91	20.74	20.74	20.6	20.67	22.71	22.54	22.54	22.4	22.47	pass
		12	6	20.88	20.61	20.83	20.49	20.72	22.68	22.41	22.63	22.29	22.52	pass
		12	13	20.96	20.64	20.94	20.42	21.05	22.76	22.44	22.74	22.22	22.85	pass
		25	0	20.92	20.66	20.81	20.49	20.89	22.72	22.46	22.61	22.29	22.69	pass
	16QAM	1	0	21.04	21.12	21.11	20.97	20.83	22.84	22.92	22.91	22.77	22.63	pass
		1	13	21.02	20.67	20.92	20.61	20.91	22.82	22.47	22.72	22.41	22.71	pass
		1	24	20.96	20.8	21.25	20.61	21.5	22.76	22.6	23.05	22.41	23.3	pass
		12	0	20.2	19.67	19.9	19.76	19.66	22.00	21.47	21.7	21.56	21.46	pass
		12	6	20.07	19.59	19.98	19.58	19.76	21.87	21.39	21.78	21.38	21.56	pass
		12	13	20.12	19.56	20.14	19.61	20.1	21.92	21.36	21.94	21.41	21.9	pass
		25	0	20.12	19.57	19.97	19.64	19.94	21.92	21.37	21.77	21.44	21.74	pass
	64QAM	1	0	20.88	20.89	20.87	20.77	20.17	22.68	22.69	22.67	22.57	21.97	pass
		1	13	20.82	20.44	20.67	20.38	20.25	22.62	22.24	22.47	22.18	22.05	pass
		1	24	20.8	20.52	21.01	20.35	20.95	22.6	22.32	22.81	22.15	22.75	pass
		12	0	20.19	19.61	19.88	19.71	19.26	21.99	21.41	21.68	21.51	21.06	pass
		12	6	20.04	19.5	19.91	19.54	19.28	21.84	21.3	21.71	21.34	21.08	pass
		12	13	20.07	19.47	20.07	19.54	19.62	21.87	21.27	21.87	21.34	21.42	pass
		25	0	20.17	19.59	19.99	19.67	19.58	21.97	21.39	21.79	21.47	21.38	pass
Bandwidth	Modulation	RB allocation	offset	Channel/Frequency(MHz)					Channel/Frequency(MHz)					Verdict
				3970	4016	4062	4108	4154	3970	4016	4062	4108	4154	
				0/	0/	0/	0/	0/	0/	0/	0/	0/	0/	
				2501	2547	2593	2639	2685	2501	2547	2593	2639	2685	
10MHz	QPSK	1	0	21.8	22.25	21.87	21.79	21.86	23.6	24.05	23.67	23.59	23.66	pass
		1	25	21.68	21.75	21.69	21.42	21.94	23.48	23.55	23.49	23.22	23.74	pass
		1	49	21.72	21.83	22.06	21.43	22.9	23.52	23.63	23.86	23.23	24.7	pass
		25	0	20.94	20.79	20.78	20.65	20.71	22.74	22.59	22.58	22.45	22.51	pass
		25	13	20.91	20.66	20.87	20.54	20.76	22.71	22.46	22.67	22.34	22.56	pass
		25	25	20.98	20.68	20.99	20.46	21.1	22.78	22.48	22.79	22.26	22.9	pass
		50	0	20.96	20.68	20.85	20.51	20.93	22.76	22.48	22.65	22.31	22.73	pass



	16QAM	1	0	21.06	21.15	21.13	21	20.85	22.86	22.95	22.93	22.8	22.65	pass
		1	25	21.05	20.71	20.95	20.65	20.94	22.85	22.51	22.75	22.45	22.74	pass
		1	49	20.99	20.82	21.28	20.63	21.53	22.79	22.62	23.08	22.43	23.33	pass
		25	0	20.23	19.72	19.94	19.81	19.7	22.03	21.52	21.74	21.61	21.5	pass
		25	13	20.09	19.63	20.01	19.62	19.79	21.89	21.43	21.81	21.42	21.59	pass
		25	25	20.15	19.61	20.18	19.66	20.14	21.95	21.41	21.98	21.46	21.94	pass
		50	0	20.15	19.62	20.01	19.69	19.98	21.95	21.42	21.81	21.49	21.78	pass
	64QAM	1	0	20.9	20.88	20.89	20.76	20.19	22.7	22.68	22.69	22.56	21.99	pass
		1	25	20.85	20.44	20.7	20.38	20.28	22.65	22.24	22.5	22.18	22.08	pass
		1	49	20.79	20.54	21.04	20.37	20.98	22.59	22.34	22.84	22.17	22.78	pass
		25	0	20.22	19.66	19.88	19.76	19.26	22.02	21.46	21.68	21.56	21.06	pass
		25	13	20.06	19.54	19.94	19.58	19.31	21.86	21.34	21.74	21.38	21.11	pass
		25	25	20.1	19.52	20.11	19.59	19.66	21.9	21.32	21.91	21.39	21.46	pass
		50	0	20.2	19.64	20.03	19.72	19.62	22	21.44	21.83	21.52	21.42	pass
<b>Bandwidth</b>	<b>Modulation</b>	<b>RB allocation</b>	<b>offset</b>	<b>Channel/Frequency(MHz)</b>					<b>Channel/Frequency(MHz)</b>					<b>Verdict</b>
				3972 5/ 2503. 5	4017 3/ 2548. 3	4062 0/ 2593	4106 8/ 2637. 8	4151 5/ 2682. 5	3972 5/ 2503. 5	4017 3/ 2548. 3	4062 0/ 2593	4106 8/ 2637. 8	4151 5/ 2682. 5	
<b>15MHz</b>	QPSK	1	0	21.79	22.21	21.85	21.75	21.84	23.59	24.01	23.65	23.55	23.64	pass
		1	38	21.66	21.74	21.66	21.41	21.91	23.46	23.54	23.46	23.21	23.71	pass
		1	74	21.69	21.78	22.02	21.38	22.86	23.49	23.58	23.82	23.18	24.66	pass
		36	0	20.92	20.75	20.75	20.61	20.68	22.72	22.55	22.55	22.41	22.48	pass
		36	18	20.88	20.61	20.83	20.49	20.72	22.68	22.41	22.63	22.29	22.52	pass
		36	39	20.95	20.65	20.95	20.43	21.06	22.75	22.45	22.75	22.23	22.86	pass
		75	0	20.94	20.64	20.8	20.47	20.88	22.74	22.44	22.6	22.27	22.68	pass
	16QAM	1	0	21.01	21.13	21.11	20.98	20.83	22.81	22.93	22.91	22.78	22.63	pass
		1	38	21.03	20.68	20.93	20.62	20.92	22.83	22.48	22.73	22.42	22.72	pass
		1	74	20.96	20.78	21.25	20.59	21.5	22.76	22.58	23.05	22.39	23.3	pass
		36	0	20.2	19.7	19.91	19.79	19.67	22	21.5	21.71	21.59	21.47	pass
		36	18	20.06	19.58	19.97	19.57	19.75	21.86	21.38	21.77	21.37	21.55	pass
		36	39	20.13	19.57	20.15	19.62	20.11	21.93	21.37	21.95	21.42	21.91	pass
		75	0	20.12	19.57	19.97	19.64	19.94	21.92	21.37	21.77	21.44	21.74	pass
	64QAM	1	0	20.85	20.86	20.87	20.74	20.17	22.65	22.66	22.67	22.54	21.97	pass
		1	38	20.83	20.41	20.68	20.35	20.26	22.63	22.21	22.48	22.15	22.06	pass
		1	74	20.8	20.53	21.05	20.36	20.99	22.6	22.33	22.85	22.16	22.79	pass
		36	0	20.21	19.68	19.89	19.78	19.27	22.01	21.48	21.69	21.58	21.07	pass
		36	18	20.04	19.51	19.93	19.55	19.3	21.84	21.31	21.73	21.35	21.1	pass
		36	39	20.08	19.48	20.08	19.55	19.63	21.88	21.28	21.88	21.35	21.43	pass



Bandwidth	Modulation	RB allocation	offset	Channel/Frequency(MHz)					Channel/Frequency(MHz)					Verdict
				3975	4018	4062	4105	4149	3975	4018	4062	4105	4149	
				0/2506	5/2549.5	0/2593	5/2636.5	0/2680	0/2506	5/2549.5	0/2593	5/2636.5	0/2680	
		75	0	20.17	19.59	19.99	19.67	19.58	21.97	21.39	21.79	21.47	21.38	pass
20MHz	QPSK	1	0	21.76	22.17	21.82	21.71	21.81	23.56	23.97	23.62	23.51	23.61	pass
		1	50	21.65	21.7	21.64	21.37	21.89	23.45	23.5	23.44	23.17	23.69	pass
		1	99	21.67	21.77	21.99	21.37	22.83	23.47	23.57	23.79	23.17	24.63	pass
		50	0	20.89	20.7	20.71	20.56	20.64	22.69	22.5	22.51	22.36	22.44	pass
		50	25	20.86	20.57	20.8	20.45	20.69	22.66	22.37	22.6	22.25	22.49	pass
		50	50	20.92	20.6	20.91	20.38	21.02	22.72	22.4	22.71	22.18	22.82	pass
		100	0	20.91	20.59	20.76	20.42	20.84	22.71	22.39	22.56	22.22	22.64	pass
	16QAM	1	0	21.02	21.09	21.06	20.94	20.78	22.82	22.89	22.86	22.74	22.58	pass
		1	50	20.99	20.66	20.89	20.6	20.88	22.79	22.46	22.69	22.4	22.68	pass
		1	99	20.94	20.75	21.23	20.56	21.48	22.74	22.55	23.03	22.36	23.28	pass
		50	0	20.17	19.66	19.88	19.75	19.64	21.97	21.46	21.68	21.55	21.44	pass
		50	25	20.03	19.56	19.94	19.55	19.72	21.83	21.36	21.74	21.35	21.52	pass
		50	50	20.1	19.52	20.11	19.57	20.07	21.9	21.32	21.91	21.37	21.87	pass
		100	0	20.1	19.53	19.94	19.6	19.91	21.9	21.33	21.74	21.4	21.71	pass
	64QAM	1	0	20.83	20.82	20.82	20.7	20.12	22.63	22.62	22.62	22.5	21.92	pass
		1	50	20.79	20.39	20.64	20.33	20.22	22.59	22.19	22.44	22.13	22.02	pass
		1	99	20.74	20.47	20.99	20.3	20.93	22.54	22.27	22.79	22.1	22.73	pass
		50	0	20.16	19.6	19.82	19.7	19.2	21.96	21.4	21.62	21.5	21	pass
		50	25	20	19.47	19.87	19.51	19.24	21.8	21.27	21.67	21.31	21.04	pass
		50	50	20.05	19.43	20.04	19.5	19.59	21.85	21.23	21.84	21.3	21.39	pass
		100	0	20.15	19.55	19.96	19.63	19.55	21.95	21.35	21.76	21.43	21.35	pass

## 5.2 Radiates Spurious Emission

### Ambient condition

Temperature	Relative humidity	Pressure
23°C ~25°C	45%~50%	101.5kPa

### Method of Measurement

1. The testing follows FCC KDB 971168 D01 v03r01 Section 5.8 and ANSI C63.26 (2015).
2. Below 1GHz: The EUT is placed on a turntable 0.8 meters above the ground in the chamber, 3 meter away from the antenna. The maximal emission value is acquired by adjusting the antenna height, polarisation and turntable azimuth. Normally, the height range of antenna is 1 m to 4 m, the azimuth range of turntable is 0° to 360°, and the receive antenna has two polarizations Vertical (V) and Horizontal (H). Above 1GHz: (Note: the FCC's permission to use 1.5m as an alternative per TCBC Conf call of Dec. 2, 2014.) The EUT is placed on a turntable 1.5 meters above the ground in the chamber, 3 meter away from the antenna. The maximal emission value is acquired by adjusting the antenna height, polarisation and turntable azimuth. Normally, the height range of antenna is 1 m to 4 m, the azimuth range of turntable is 0° to 360°, and the receive antenna has two polarizations Vertical (V) and Horizontal (H).
3. A loop antenna, A log-periodic antenna or horn antenna shall be substituted in place of the EUT. The log-periodic antenna will be driven by a signal generator and the level will be adjusted till the same power value on the spectrum analyzer or receiver. The level of the spurious emissions can be calculated through the level of the signal generator, cable loss, the gain of the substitution antenna and the reading of the spectrum analyzer or receiver.
4. The EUT is then put into continuously transmitting mode at its maximum power level during the test. Set Test Receiver or Spectrum RBW=200Hz,VBW=600Hz for 9kHz150kHz , RBW=10kHz, VBW=30kHz 150kHz-30MHz ,RBW=100kHz,VBW=300kHz for 30MHz to 1GHz and RBW=1MHz, VBW=3MHz for above 1GHz And the maximum value of the receiver should be recorded as (Pr).
5. The EUT shall be replaced by a substitution antenna. In the chamber, an substitution antenna for the frequency band of interest is placed at the reference point of the chamber. An RF Signal source for the frequency band of interest is connected to the substitution antenna with a cable that has been constructed to not interfere with the radiation pattern of the antenna. A power (PMea) is applied to the input of the substitution antenna, and adjust the level of the signal generator output until the value of the receiver reach the previously recorded (Pr). The power of signal source (PMea) is recorded. The test should be performed by rotating the test item and adjusting the receiving antenna polarization.
6. A amplifier should be connected to the Signal Source output port. And the cable should be connect between the Amplifier and the Substitution Antenna. The cable loss (Pcl) ,the Substitution Antenna Gain (Ga) and the Amplifier Gain (PAG) should be recorded after test.
7. The measurement results are obtained as described below:  
Power(EIRP)=PMea- PAG - Pcl + Ga  
The measurement results are amend as described below:  
Power(EIRP)=PMea- Pcl + Ga
8. This value is EIRP since the measurement is calibrated using an antenna of known gain (2.15 dBi) and known input power. ERP can be calculated from EIRP by subtracting the gain of the dipole, ERP

= EIRP-2.15dBi.

The modulation mode and RB allocation refer to section 5.1, using the maximum output power configuration.

**Test setup**

**9KHz ~ 30MHz**

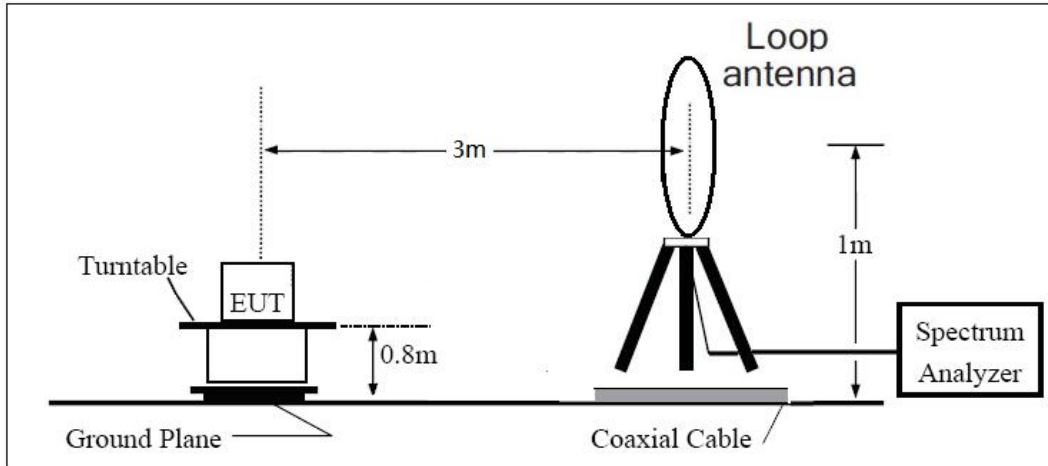

**30MHz ~ 1GHz**

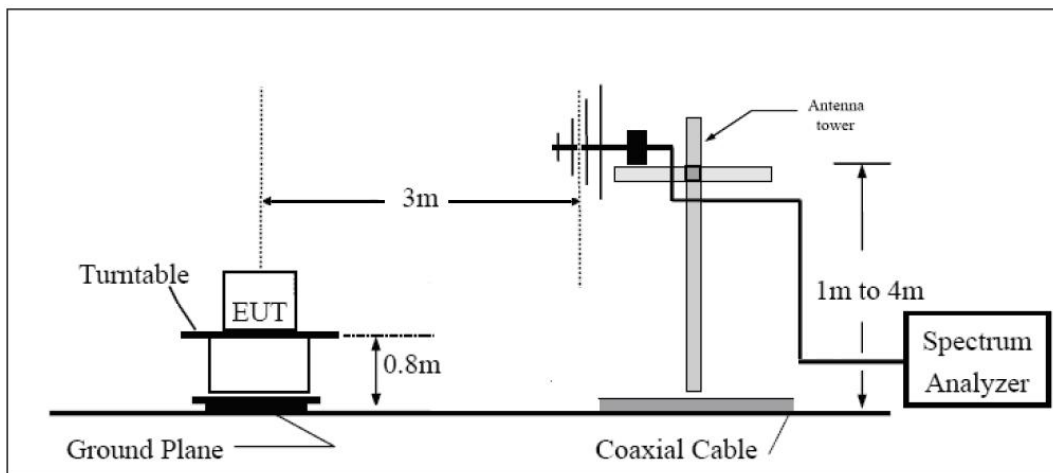

**Above 1GHz**

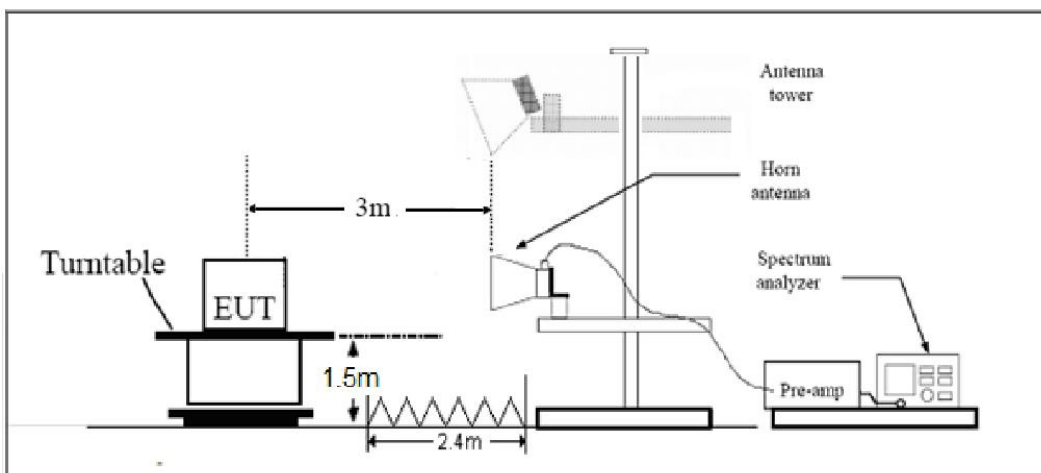

Note: Area side:2.4mX3.6m

**Limits**

LTE -7 Rule Part 27.53(m)  $55 + 10 \log (P)$  dB on all frequencies more than X megahertz from the channel edge, where X is the greater of 6 megahertz or the actual emission bandwidth as defined in paragraph (m)(4) of this section.

Part 27.53(m) Limit	-25 dBm
---------------------	---------

**Measurement Uncertainty**

The assessed measurement uncertainty to ensure 95% confidence level for the normal distribution is with the coverage factor  $k = \pm 1.96$ ,  $U = \pm 3.55$  dB.



**Test Result**

Sweep the whole frequency band through the range from 9kHz to the 10th harmonic of the carrier, the emissions below the noise floor will not be recorded in the report.

LTE Band 41 QPSK 5MHz CH-Middle, RB 1

Harmonic	Frequency (MHz)	SG (dBm)	Cable Loss (dB)	Gain (dBi)	Antenna Polarization	EIRP Level (dBm)	Limit (dBm)	Margin (dB)	Azimuth (deg)
2	5181.8	-52.15	2.00	9.15	Horizontal	-45.00	-25.00	20.00	315.00
3	7772.3	-46.01	2.50	11.35	Horizontal	-37.16	-25.00	12.16	225.00
4	10365.0	-50.53	4.20	12.05	Horizontal	-42.68	-25.00	17.68	90.00
5	12965.0	-52.75	5.20	12.85	Horizontal	-45.10	-25.00	20.10	180.00
6	15558.0	-49.44	5.50	14.23	Horizontal	-40.71	-25.00	15.71	45.00
7	18151.0	--	--	--	--	--	--	--	--
8	20744.0	--	--	--	--	--	--	--	--
9	23337.0	--	--	--	--	--	--	--	--
10	25930.0	--	--	--	--	--	--	--	--

Note: 1.The other Spurious RF Radiated emissions level is no more than noise floor.  
 2. The worst emission was found in the antenna is Horizontal position.

LTE Band 41 QPSK 20MHz CH-Middle, RB 1

Harmonic	Frequency (MHz)	SG (dBm)	Cable Loss (dB)	Gain (dBi)	Antenna Polarization	EIRP Level (dBm)	Limit (dBm)	Margin (dB)	Azimuth (deg)
2	5168.3	-53.99	2.00	10.15	Horizontal	-45.84	-25.00	20.84	90.00
3	7752.0	-46.44	2.50	11.35	Horizontal	-37.59	-25.00	12.59	45.00
4	10336.5	-52.48	4.20	12.05	Horizontal	-44.63	-25.00	19.63	180.00
5	12918.8	-55.48	5.20	14.85	Horizontal	-45.83	-25.00	20.83	225.00
6	15504.8	-48.12	5.50	13.23	Horizontal	-40.39	-25.00	15.39	135.00
7	18151.0	--	--	--	--	--	--	--	--
8	20744.0	--	--	--	--	--	--	--	--
9	23337.0	--	--	--	--	--	--	--	--
10	25930.0	--	--	--	--	--	--	--	--

Note: 1.The other Spurious RF Radiated emissions level is no more than noise floor.  
 2. The worst emission was found in the antenna is Horizontal position.



## 6 Main Test Instruments

Name	Manufacturer	Type	Serial Number	Calibration Date	Expiration Date
Base Station Simulator	R&S	CMW500	113824	2019-05-19	2020-05-18
Power Splitter	Hua Xiang	SHX-GF2-2-13	10120101	/	/
Spectrum Analyzer	Key sight	N9010A	MY50210259	2019-05-19	2020-05-18
Signal Analyzer	R&S	FSV30	100815	2019-12-15	2020-12-14
Loop Antenna	SCHWARZBECK	FMZB1519	1519-047	2017-09-26	2020-09-25
Trilog Antenna	SCHWARZBECK	VUBL 9163	9163-201	2017-11-18	2020-11-17
Horn Antenna	R&S	HF907	100126	2018-07-07	2020-07-06
Horn Antenna	ETS-Lindgren	3160-09	00102643	2018-06-20	2020-06-19
Signal generator	R&S	SMB 100A	102594	2019-05-19	2020-05-18
Climatic Chamber	ESPEC	SU-242	93000506	2017-12-17	2020-12-16
Preamplifier	R&S	SCU18	102327	2019-05-19	2020-05-18
MOB COMMS DC SUPPLY	Keysight	66319D	MY43004105	2019-05-19	2020-05-18
RF Cable	Agilent	SMA 15cm	0001	2019-12-13	2020-6-12
Software	R&S	EMC32	9.26.0	/	/

\*\*\*\*\*END OF REPORT \*\*\*\*\*