



Naída CI M90 Sound Processor

CI-5293



Advanced Bionics AG

Laubisrütistrasse 28

8712 Stäfa, Switzerland

+41 58 928 78 00

Manufactured by:

Advanced Bionics LLC

California, USA













+1 661 362 1400

AdvancedBionics.com

029-M796-A2 Rev A 2020-03-02

SYMBOLS TABLE:

Labeling symbols and their meanings:

| | |
|---|--|
|  | Date of Manufacture |
|  | Manufacturer |
|  | Model number |
|  | Serial number |
|  | Unique Device Identifier |
|  | Type of Protection: BF |
|  | Suitable temperature range for transport and storage |
|  | See Instructions for Use |
|  | Fragile |
|  | Suitable relative humidity range for transport and storage |
|  | Caution (refer to “Cautions & Warnings” section for further information) |
|  | Dispose of in accordance with applicable national and local regulations |
|  | MR Unsafe |
| IPXX | Ingress Protection Rating |

LIMITATIONS AND CONTRAINDICATIONS:

There are no known limitations or contraindications for the Naída CI M90 sound processor.

PRECAUTIONS, CAUTIONS, AND WARNINGS:

- This device should be used only by the individual for whom it is prescribed.
- **CHOKING HAZARD:** Contains small parts that pose a hazard of inhalation, choking, or ingestion. Using your sound processor and accessories contradictory to their intended use (e.g. mouthing, chewing) may cause bodily harm. If any parts are swallowed or inhaled, consult a physician or hospital immediately.
- Ensure appropriate supervision when child is wearing the Naída CI M90 sound processor and accessories. Do not allow children to play with or leave them unattended with the sound processor or any of its accessories.
- Power supplies and battery chargers should be operated in an open area to ensure adequate airflow. While no injury cases have resulted, components may become hot during normal use or a fault condition. If the device's temperature results in discomfort or pain when touched, disconnect the power source and contact your local Advanced Bionics representative.
- Do not use any other power supply with the sound processor or accessories unless it is supplied by Advanced Bionics. If needed, please call Advanced Bionics for a power supply replacement.
- Do not use accessories when they are plugged into power sources such as wall outlets, or other power sources that are USB compatible (e.g. laptops).
- Do not allow leaking battery fluid to come into contact with skin, mouth, or eyes.
- Do not expose batteries to heat (e.g., do not store in direct sunlight or in a hot car).
- Remove batteries from your sound processor when they are drained to prevent damage from possible leaking.
- Do not dispose of batteries in fire.
- High levels of static electricity may damage electronic components of your sound processor or implant. Care should be taken to avoid exposure of the system to static electricity.
- Do not attempt to pair your sound processor to any accessories while driving or operating heavy machinery.
- Do not stream audio to your sound processor while driving or operating heavy machinery.
- Attenuating ambient sounds or adjusting environmental balance while streaming audio (either with the multifunction button or with the mobile application) may compromise situational awareness.
- Use your sound processor for hands-free phone use only where permitted by law and only when you will not be distracted from the safe operation of your vehicle.
- Do not use your Advanced Bionics wireless accessories when instructed not to use wireless electronic devices, such as on airplanes.
- Remove your sound processor and headpiece before entering a room where an MRI scanner is located.

- Remove your sound processor and consult your cochlear implant professional if uncomfortable sounds are heard or in case of discomfort, pain or skin irritation.
- If the sound processor or accessories become unusually hot or warm, discontinue use immediately and contact Advanced Bionics or your cochlear implant professional.
- The large Slim HP Color Cap is for use by recipients older than 3 years of age, as this color cap and the Slim HP magnet may become displaced upon dropping.
- It is important to have the correct magnet strength, so you do not experience discomfort or retention issues. If magnet strength is insufficient, the headpiece may fall off more than is acceptable. If magnet strength is excessive, you may experience irritation or discomfort. Consult your cochlear implant professional if there are any concerns regarding magnet strength. If deemed appropriate, an audiologist may change the strength of the magnet in the headpiece. Do not change magnet strength unless under the direction of a cochlear implant professional. If you experience any redness, irritation, or discomfort, discontinue use of the headpiece immediately and contact a cochlear implant professional. See the headpiece instructions for use for additional information regarding adjustment of headpiece magnet strength.
- Store additional headpieces away from items with magnetic strips (e.g., credit cards, hotel room keys, etc.) as they may de-magnetize cards.
- The digitally-coded, inductive transmission technology used in this device is extremely reliable and experiences virtually no interference from other devices. It should be noted, however, that when operating the device near a computer terminal or other strong electromagnetic field (e.g. RFID system), it may be necessary to be at least 24" (60 cm) away to ensure proper operation. If the Naída CI M90 sound processor does not respond to the implant device because of an unusual field disturbance, move away from the disturbing field.
- The Naída CI M90 sound processors and accessories should be used in accordance with the electromagnetic compatibility information provided in the Guidance and Manufacturer's Declaration section of this document.
- Although electromagnetic emissions of your Naída CI M90 sound processor have been confirmed within safe limits, some other devices could be sensitive to such emissions. If you notice other devices do not behave as expected when your sound processor is nearby, separate the devices.
- Portable and mobile radio frequency (RF) communications equipment, including radios and cellular phones, may affect sound quality of the Naída CI M90 sound processor and accessories; however, there is no safety hazard associated with such equipment.
- Do not expose any part of the Naída CI M90 sound processors or accessories to extreme heat, such as an oven, microwave, or hair dryer.
- AutoSense OS 3.0, Speech in Loud Noise, UltraZoom, UltraZoom + SNR Boost, and Speech in 360 programs may dampen sounds that are not in front of the recipient.
- Use of WindBlock, EchoBlock, SoundRelax, NoiseBlock, and/or WhistleBlock may affect the quality of sound.
- Do not use any programs other than an off-ear program when utilizing any off-ear wearing configuration (e.g., in a clip, in the M Waterproof Battery).

- NOTE: In the United States, StereoZoom, auto UltraZoom, SoundRelax, WindBlock, and EchoBlock are approved for use in pediatric recipients 6 years and above who are 1) able to complete objective speech perception testing in order to determine speech performance and 2) able to report a preference for different coding strategies or features.
- In the event that you experience any issues with your product, please contact your cochlear implant professional or the manufacturer. Do not attempt to service or modify the Naída CI or its accessories. Doing so may compromise system performance and will void the manufacturer’s warranty. Products should be serviced only at Advanced Bionics and damaged products should be returned to Advanced Bionics.

UNDESIRABLE SIDE EFFECTS:

Undesirable side effects of your Naída CI M90 system may include skin irritation and discomfort from pressure on the ear, device overheating, or overly loud sounds. If any undesirable side effect is encountered, please remove your sound processor and consult your cochlear implant professional.

PRODUCT DESCRIPTION AND PERFORMANCE CHARACTERISTICS:

The Naída CI M90 Sound Processor is a behind-the-ear (BTE) sound processor for use with an Advanced Bionics cochlear implant. The Naída CI M90 is comprised of the components pictured below.

FPO Image



The Naída CI M90 sound processor features direct connectivity to wireless accessories and Bluetooth-enabled devices. The Naída CI M90 offers multiple power options and wearing options for the user.

The system is designed to provide useful hearing to individuals with severe-to-profound hearing loss.

INTENDED USE:

The Naída CI M90 is a behind-the-ear (BTE) sound processor that converts sound picked up by the microphone or streamed via wireless communication into electrical signals that are used by the cochlear implant to enable hearing.

The intended users of the Naída CI M90 sound processor are recipients of Advanced Bionics cochlear implants. The intended use environments of the Naída CI M90 sound processor are healthcare and daily living environments.

COMPATIBILITY:

The Naída CI M90 is compatible with the following implant types from Advanced Bionics:

- CII
- HiRes 90K
- HiRes 90K Advantage
- HiRes Ultra
- HiRes Ultra 3D

The Naída CI M90 is compatible with the following Advanced Bionics products:

- M Batteries, M Zn-Air Battery Pak, M Waterproof Battery
- M T-Mic, M Earhook, M Acoustic Earhook
- Slim HP, Slim HP Mic, Slim HP AquaMic
- M Wearing Clip, M Snuggie, M Retention Cuff, M Listening Check

The Naída CI M90 is compatible with the following programming interfaces:

- Advanced Bionics Clinical Programming Interface CPI-3 with the M Programming Cable
- NoahLink Wireless programmer

The Naída CI M90 is compatible with the following accessory products:

- AB Remote mobile application
- Phonak Roger transmitters
- Phonak RemoteControl
- Phonak TV Connector
- Phonak PartnerMic
- Phonak Naída Link M hearing instrument

The Naída CI M90 sound processor is Bluetooth 4.2 certified. Any mobile device that supports Bluetooth, Hands Free Profile (HFP) and/or Advanced Audio Distribution Profile (A2DP) should work with your Naída CI M90 sound processor. Bluetooth compatibility information should be used as a reference guide only, because hardware and software levels and releases may vary, and numerous hardware and software combinations are possible. Advanced Bionics assumes no responsibility for the compatibility;

thus, it is the user's responsibility to do product compatibility testing by himself before making purchasing decisions on smartphones and other Bluetooth-enabled devices.

OPERATING INSTRUCTIONS:

Powering Naída CI M90

The sound processor is turned on when a charged battery is attached to the sound processor. When the battery is first attached, the orange LED located in the middle of the rocker switch will indicate battery charge.

The startup program is selected by the cochlear implant professional during programming.

To power down the Naída CI M90 sound processor, simply remove the battery.

Attaching the Battery

Hold the Naída CI M90 in one hand. Rotate the headpiece cable upward in order to avoid bumping it upon battery placement.

FPO Image

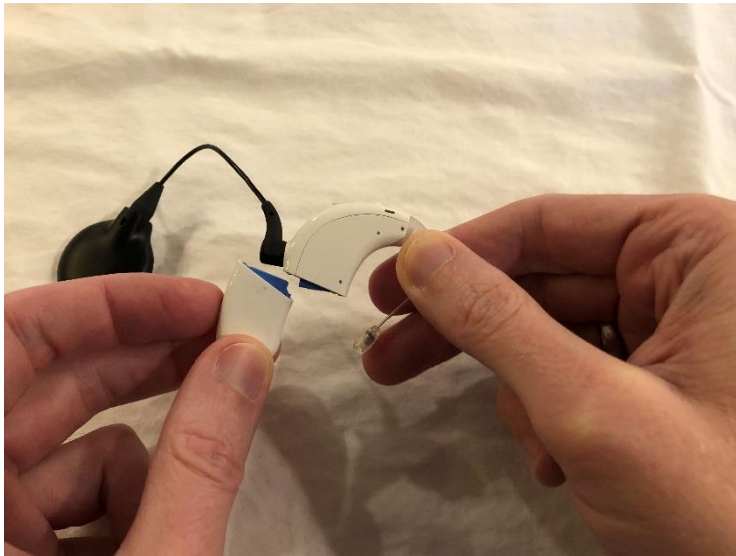

Align the battery connector with the sound processor housing side of the connector.

FPO Image

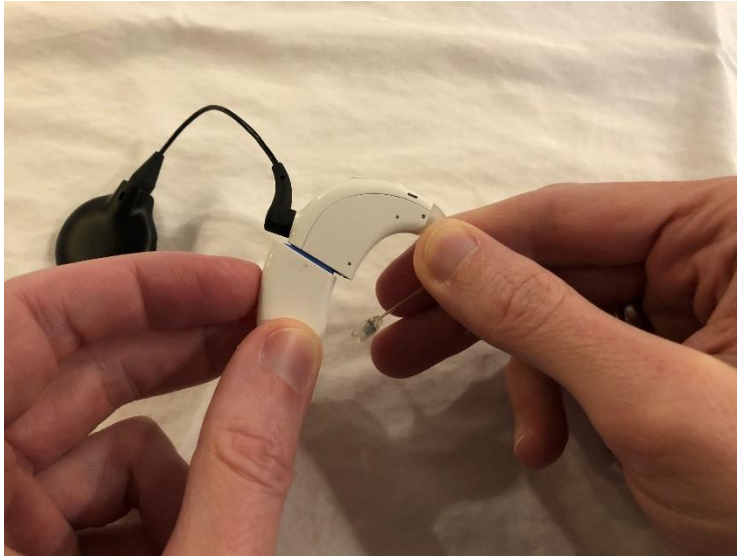

Slide the battery onto the sound processor until it clicks into place. Do not force the battery onto the sound processor. The batteries are designed to be inserted in only one direction; applying force may damage the equipment.

FPO Image



Removing the Battery

Hold the Naída CI M90 in one hand. In the other hand, hold the battery. Rotate the headpiece cable upward in order to avoid bumping it upon battery removal.

FPO Image



Firmly slide the battery away from the M T-Mic, M Earhook, or M Acoustic Earhook.

FPO Image

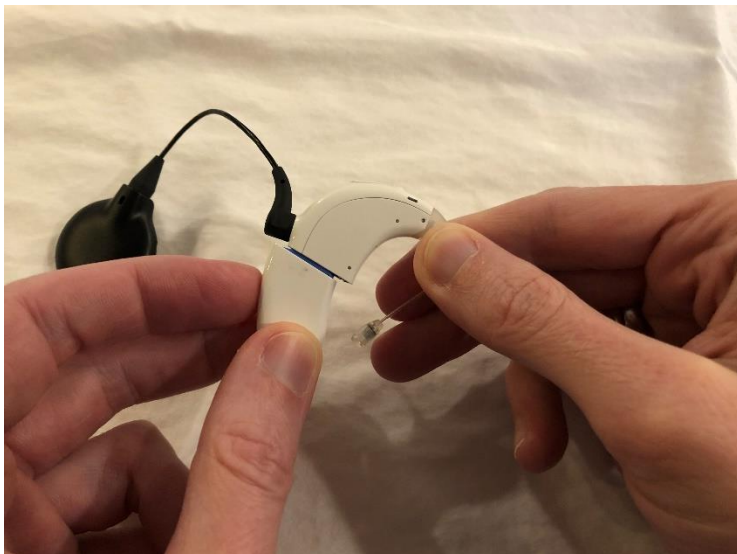

Continue sliding the battery until it separates from the sound processor.

FPO Image

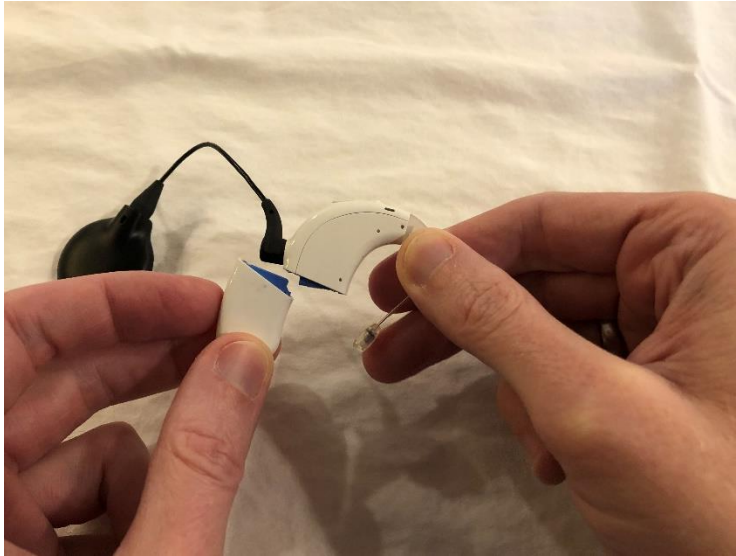

Approved Naída CI M90 Power Supplies

| Power Supply | Nominal Voltage | Type | Rated Capacity |
|----------------------|-----------------|-----------------------|----------------|
| M Battery | 3.6V – 3.7V | Li-ion (rechargeable) | 0.3Wh – 0.8Wh |
| M Waterproof Battery | 3.7V | Li-ion (rechargeable) | 0.8Wh |
| M Zn-Air Battery Pak | 2.3V | Zn-air (disposable) | 1.4Wh |

Connecting the earhook to the sound processor

There are three earhook options for the Naída CI M90 sound processor: the M T-Mic, the M Earhook, and the M Acoustic Earhook.

Beginning with the earhook disconnected, align the earhook flush with the sound processor. Hold the earhook firmly at the top and push towards the sound processor until it meets flush with the sound processor.

FPO Image

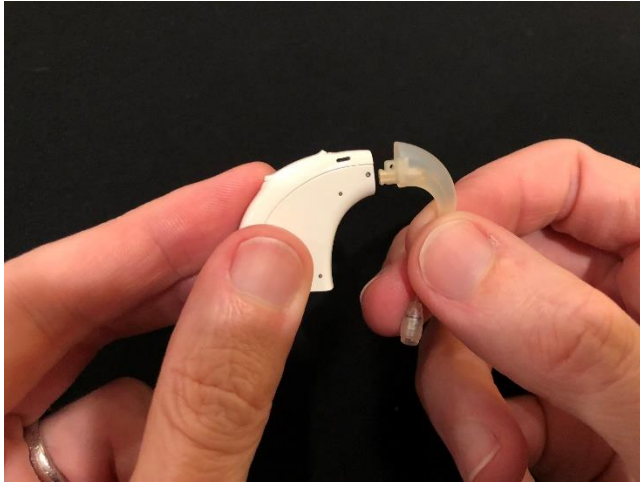

Using the provided pin removal tool, place one of the pins in the small hole on the side of the tool. This will help to steady the pin as you line it up with the pin hole on the earhook.

FPO Image

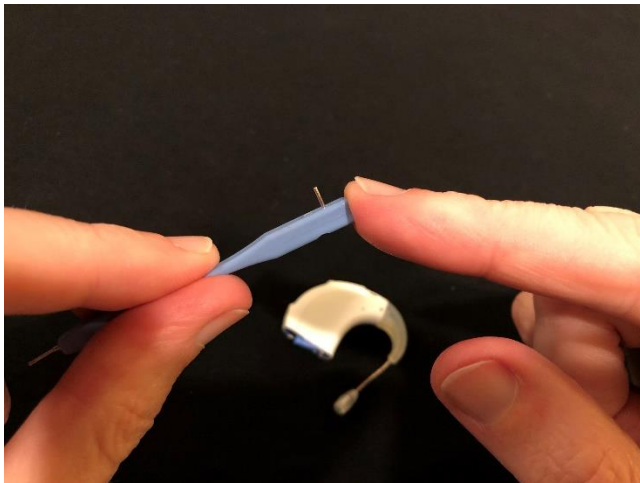

Line up the pin with the hole in the earhook and gently push it through the hole. The pin will move from one side of the sound processor, through the earhook to the other side of the sound processor, holding the earhook in place. The pin should not come out the other side.

FPO Image

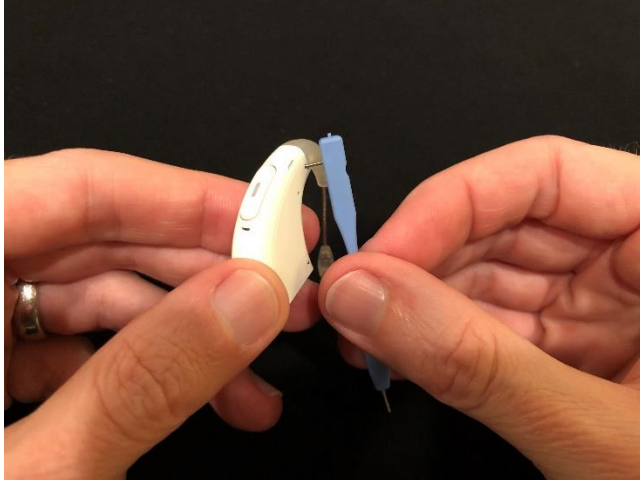

If a small portion of the pin extends beyond the sound processor, use the side of the tool to push the pin inwards so it lies flush with the sound processor.

FPO Image



Pull the tool away from the sound processor, leaving the pin inside the sound processor.

FPO Image

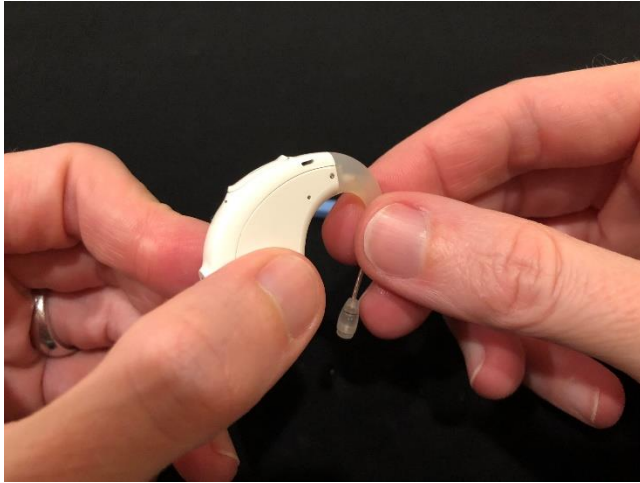

Removing the earhook

Align the pointed end of the tool with the hole on the sound processor that contains the pin holding the earhook on the sound processor.

FPO Image

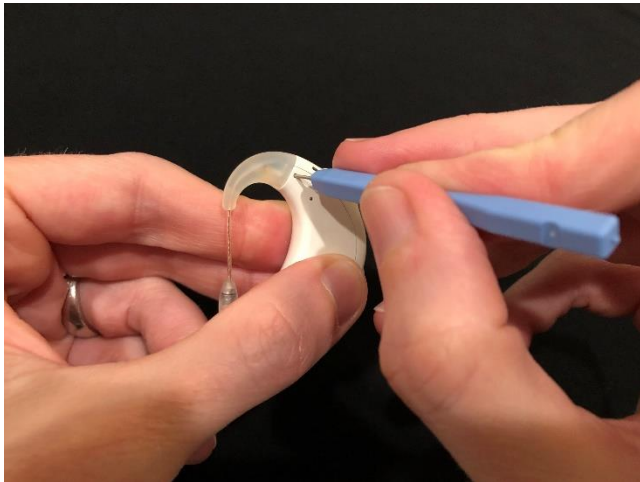

Gently press the tool in the hole, pushing the pin out the other side.

FPO Image

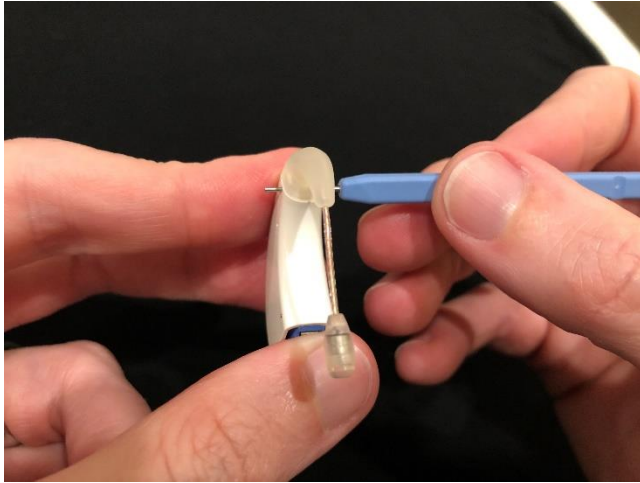

The pin does not need to be removed from the sound processor. As long as the tool is pushed in flush on one side of the sound processor, the pin should be displaced enough to adequately remove the earhook. Remove the tool from the sound processor. Gently grasp the earhook at the top near where it connects with the sound processor and pull forward until it is separated from the sound processor.

FPO Image

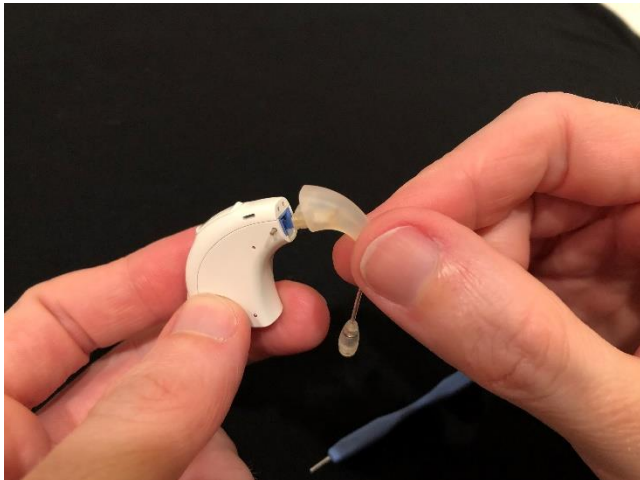

Attaching the headpiece cable to the sound processor

To attach the headpiece cable to the sound processor, hold the headpiece cable by the cable's strain relief. Align the connector on the cable with the connector on the sound processor and gently push the cable into the sound processor until it snaps into place.

FPO Image

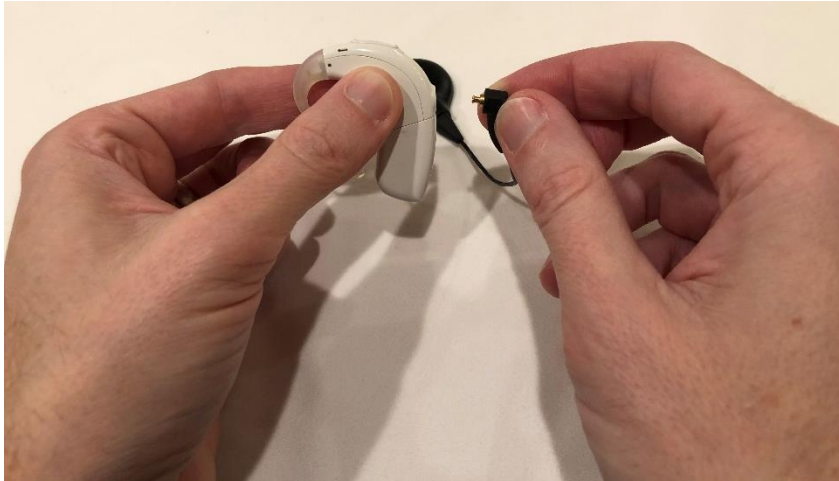

Removing the Slim HP cable from the sound processor

Remove the battery from the processor before removing the cable from the processor. To remove the cable from the sound processor, always hold the cable's strain relief and gently pull it away.

FPO Image

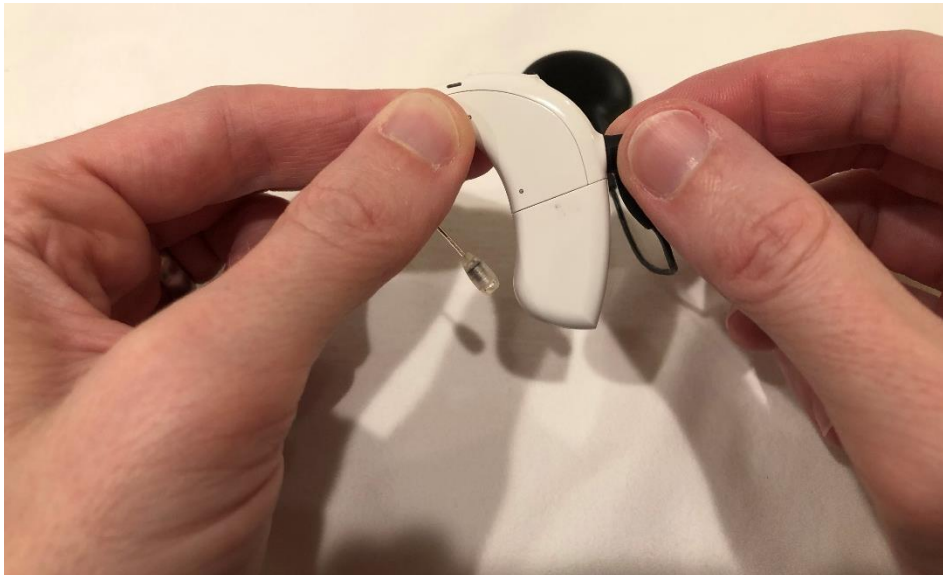

NOTE: To maximize cable life, the cable should only be unplugged from the sound processor when changing wearing configuration or when replacing the cable.

Naída CI M90 LEDs

The LED is a programmable feature that provides visual information about the Naída CI M sound processor status, battery life, program position, and sound processor error conditions.

| Indication | Color | Behavior | Programmable |
|----------------------------|--------|---|--------------|
| Battery Status at Start-Up | Orange | <p>Blinks at start-up with use of rechargeable batteries (not available with M Zn-Air Battery Pak)</p> <ul style="list-style-type: none"> • 4 quick blinks indicate that the battery is fully-charged. • 2 or 3 quick blinks indicate that the battery is sufficiently charged to power the sound processor. • 1 quick blink indicates that the battery is nearly depleted. • No blinking indicates the battery is depleted; replace with a charged or new battery. | No |
| Low Battery | Orange | Continuous Blinking | No |
| Current Program | Green | <p>Blinks at start-up after battery status and upon program change</p> <ul style="list-style-type: none"> • 1 long blink is AutoSense program • 1 short blink is program 1 • 2 short blinks is program 2 • 3 short blinks is program 3 • 4 short blinks is program 4 | Yes |
| Flight Mode | Orange | One long blink at start-up after battery and program status | No |
| Progressive Program Change | Purple | 1 blink upon changing | Yes |
| Loud Input | Green | Blinks during use in response to loud input sounds. Indicates the sound processor and microphone are responding to sound. | Yes |
| Streaming Input | Blue | Blinks while streaming audio to the sound processor. Indicates the sound processor and microphone are streaming | Yes |

| | | | |
|--|-------|---|-----|
| | | audio. | |
| Loss of Lock with the Implant | Red | Slow blinking (once per second) | Yes |
| Wrong Implant | Red | Fast blinking (more than once per second) | No |
| Error Condition (remove and reattach battery to reset sound processor) | Red | Solid Red | No |
| Detect Sound Processor | Green | 3 blinks upon command from mobile application or fitting software | No |

Naída CI M90 Internal Alarms

The internal alarms are programmable and provide auditory information about the Naída CI M90 sound processor. Your cochlear implant professional can adjust the volume and pitch of the internal alarms to suit your preference.

| Indication | Behavior | Programmable |
|------------------------|--|--------------|
| Low Battery | 2 beeps | No |
| Program Change | <ul style="list-style-type: none"> • Jingle is AutoSense program • 1 beep is program 1 • 2 beeps is program 2 • 3 beeps is program 3 • 4 beeps is program 4 | Yes |
| Volume Change | <ul style="list-style-type: none"> • Long beep at end of range • 2 short beeps at middle of range • 1 short beep at intermediate steps | Yes |
| Pairing Successful | Ascending beeps | Yes |
| TV Connector Available | Ascending beeps | Yes |
| Phone Ring Tones | Ringling beeps | No |

Using the Naída CI M90 Multi-Function Button

The multifunction button has several functions which can be programmed by the hearing care professional. The button can function as a volume control and/or a program change depending on the programming. Please ask your cochlear implant professional to confirm how your sound processor is programmed.

| Situation | Short Press | Long Press |
|------------------------|-----------------------------------|-----------------------------------|
| Standard Use | Volume up or down | Program change |
| During Audio Streaming | Streaming volume up or down | Program change |
| During Phone Calls | Accept phone call (while ringing) | Reject phone call (while ringing) |

| | | |
|--|---|---------------------------------|
| | or phone call volume up or down (during call) | or end phone call (during call) |
|--|---|---------------------------------|

Connectivity Overview

The Naída CI M90 sound processor can be connected to Bluetooth-enabled devices for phone calls, VoIP calls, audio streaming, or for use with the AB Remote mobile application.

Pairing and Connecting the Naída CI M90 to a Bluetooth-Enabled Device

1. Ensure that Bluetooth wireless technology is enabled on your device (e.g., phone, tablet) and search for Bluetooth-enabled devices in the connectivity settings menu.
2. Power on the Naída CI M90 sound processor by connecting the sound processor to a power source. The sound processor will be discoverable by your Bluetooth-enabled device for up to three minutes, or until it is successfully paired to a device.
3. Your device should show a list of Bluetooth-enabled devices. Select the sound processor from the list to pair your sound processor. If you use two Naída CI M90 sound processors, selecting one sound processor for pairing will simultaneously pair both sound processors. A beep confirms successful pairing.
4. The connection will be maintained as long as the device remains on and within range.

After your sound processor has been paired to your Bluetooth-enabled device, the sound processor will automatically connect again when switched on. Your sound processor can be paired to two Bluetooth-enabled devices at a time. The paired sound processor can be unpaired from the Bluetooth device by utilizing the Bluetooth management menu of your device.

PLEASE NOTE: Once a sound processor has been paired to a device it is recommended to keep paired devices in silent mode to avoid dropouts related to device notifications.

Managing Bluetooth Phone Calls with the Naída CI M90

When the sound processor is directly connected with a Bluetooth-enabled phone, you will be able to hear the caller's voice directly through the sound processor. The sound processor picks up your voice through the sound processor microphones.

FPO Image

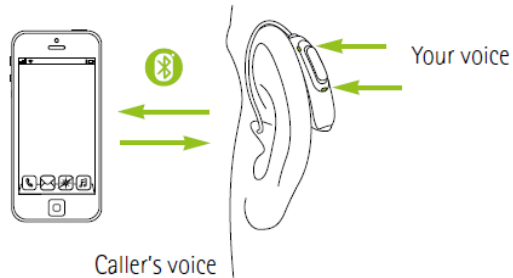

When making a phone call, you will hear a dialing tone through the sound processor. The sound processor microphones pick up your voice. When receiving a call, a call notification will be heard through the sound processor. You can accept the call with a short press on the upper or lower part of the multifunction button on the sound processor or directly on the phone.

FPO Image

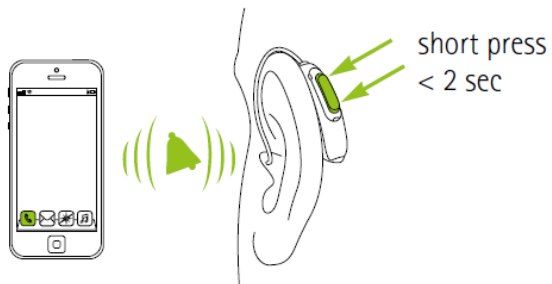

You can reject or end a call with a long press on the upper or lower part of the multifunction button on the sound processor or directly through the phone.

FPO Image

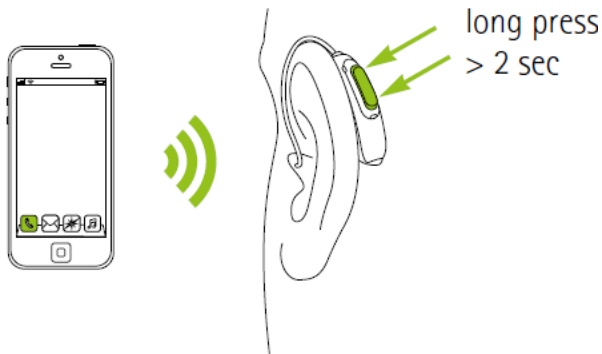

Streaming Audio via Bluetooth with the Naída CI M90

After successful pairing of your processor(s) to your Bluetooth-enabled device, ensure that your device is not muted and volume is not set to minimum. Then, simply start the audio on the Bluetooth-enabled device and the sound processor will start streaming the audio. Environmental balance and access to surrounding sounds can be managed using the multifunction button, the AB Remote mobile application, or the Phonak RemoteControl.

Pairing the Naída CI M90 to Phonak Accessories

Your Naída CI M90 can be paired to the following Phonak accessories:

- Phonak RemoteControl
- Phonak TV Connector
- Phonak PartnerMic
- Phonak Roger transmitters
- Phonak Naída Link M hearing instrument

Please refer to the accessory user guide for initial setup and pairing instructions.

Switching between Multiple Audio Sources with the Naída CI M90

A phone call from a Bluetooth-enabled device has highest priority and will pause other audio streaming from a connected device. In order to switch audio streaming source, simply pause the audio from the current source and start streaming from another source.

Placing the Naída CI M90 in Flight Mode

The Naída CI M90 communicates wirelessly with other devices in the 2.40 GHz to 2.48 GHz frequency range. When flying, some operators require all devices to be switched into flight mode. Entering flight

mode will not disable normal sound processor functionality but will disable Bluetooth connectivity functions.

Activating and Deactivating Flight Mode

1. Hold down either the top or bottom of the multifunction button while attaching the battery.
2. Continue to hold down the button while the sound processor starts up, until a long, solid orange LED is visible, approximately 10 seconds. Note that the start-up LEDs that indicate the battery life of the rechargeable battery and the program number will be seen before the long, solid orange flight mode LED.
3. Removing and reattaching the battery will take the sound processor out of flight mode.

CARE AND MAINTENANCE:

Storing the Naída CI M90

When not in use, store the Naída CI M90 in the equipment case provided.

Recommended Operating and Storage Temperature and Humidity Ranges

| Condition | Minimum | Maximum |
|-----------------------|---------------|--------------|
| Operating Temperature | 0°C (32°F) | 45°C (115°F) |
| Storage Temperature | -20°C (-13°F) | 55°C (131°F) |
| Relative Humidity | 0% | 95% |

Cleaning and Maintenance

Wipe the outside of the Naída CI M90 with a soft, dry cloth. Do not immerse in liquids or use cleaning agents for cleaning the sound processor. If the Naída CI M90 sound processor is exposed to moisture, place the device in a drying system before next use. You should remove the sound processor from the ear before using hair spray or applying cosmetics because these products may cause damage.

Ingress Protection (IP) Ratings

The following product configuration has an IP rating of 22 (protection against insertion of solid objects \geq 12.5 mm diameter; protection against failure due to dripping water when tilted up to 15°):

- The Naída CI M90 sound processor with the M Listening Check, an M Battery or M Zn-Air Battery Pak, a M T-Mic, M Earhook, or M Acoustic Earhook, and a headpiece.

The following product configuration has an IP rating of 52 (protection against dust; protection against failure due to dripping water when tilted up to 15°):

- The Naída CI M90 sound processor inside the M Waterproof Battery with a non-waterproof headpiece.

The following product configurations have an IP rating of 54 (protection against dust; protection against failure due to water splashes from all directions):

- The Naída CI M90 sound processor with an M Battery or M Zn-Air Battery Pak, an M T-Mic or M Acoustic Earhook, and a Slim HP or Slim HP Mic.
- The Naída CI M90 sound processor with an M Zn-Air Battery Pak, an M Earhook, and a Slim HP or Slim HP Mic.

The following product configuration has an IP rating of 57 (protection against dust; protection against failure due to one-time immersion for 30 minutes to a depth up to 1 meter and after drying overnight in a drying system):

- The Naída CI M90 sound processor with an M Battery, an M Earhook, and a Slim HP or Slim HP Mic.

The following product configuration has an IP rating of 68 (complete protection against dust penetration; protection against failure due to continuous immersion in water up to 3 meters):

- The Naída CI M90 sound processor inside the M Waterproof Battery with Slim HP AquaMic.

DISPOSAL AND HAZARDOUS MATERIALS:

Dispose of the Naída CI M90 sound processor and accessories in accordance with applicable national and local regulations. Hazardous materials: not applicable to this product.

AVAILABLE PRODUCT OPTIONS AND MODEL NUMBERS:

| Product Option | Model Number |
|----------------|--------------|
| Sand Beige | CI-5293-120 |
| Chestnut | CI-5293-130 |
| Silver Grey | CI-5293-140 |
| Velvet Black | CI-5293-150 |
| Alpine White | CI-5293-110 |
| Resin Beige | CI-5293-240 |

CLINICAL BENEFITS:

Advanced Bionics has completed a confirmatory study of AutoSense OS on the Naída CI M90 sound processor. A total of 10 subjects were enrolled in a prospective study using a within-subjects repeated-measures design where each subject served as his/her own control. Five subjects used the M Acoustic Earhook, while the remaining 5 used the M T-mic and electrical stimulation only. The data presented below are pooled between the two cohorts.

Sentences in Quiet at 65 dBA

Across all subjects, similar sentence recognition scores in quiet were observed between AutoSense OS and the AutoSense OS Off program. See the table below.

| | 2 List AutoSense OS Average Score (%) | 2 List AutoSense OS Off Average Score (%) |
|------------------|--|--|
| N | 10 | 10 |
| Mean (SD) | 88.92 (11.068) | 89.76 (11.677) |
| Median | 94.65 | 92.88 |
| Min, Max | 63.2, 96.7 | 61.2, 99.3 |

Sentences in Noise at 65 dBA, + 5 dB SNR Multi-Talker Babble

Across all subjects, better sentence recognition scores in noise were observed when using AutoSense OS as compared to the AutoSense OS Off program. See table below.

| | 2 List AutoSense OS Average Score (%) | 2 List AutoSense OS Off Average Score (%) |
|------------------|--|--|
| N | 10 | 10 |
| Mean (SD) | 79.29 (16.439) | 54.19 (23.826) |
| Median | 86.98 | 57.53 |
| Min, Max | 45.8, 95.3 | 19.8, 81.4 |

In quiet, 100% of subjects' AutoSense OS scores were within 10% of their AutoSense OS Off scores and in noise 90% of subjects' AutoSense OS scores were better than their AutoSense OS Off scores by 10% or more. These observed trends further demonstrate that automatic activation of the AutoSense OS features does not negatively impact sentence recognition in quiet or noise conditions. Additionally, the improvement in sentence recognition in multi-talker babble noise with AutoSense OS is evident.

Follow-Up Self-Assessment Questionnaire Results

Results were similar across sound quality and listening comfort ratings. All 10 subjects (100.0%) reported acceptable sound quality in quiet, with 9 subjects (90.0%) reporting strong agreement and 1 subject (10.0%) reporting slight agreement. Nine subjects (90.0%) reported acceptable sound quality in noise (5 subjects reported "Strongly Agree," 4 subjects reported "Slightly Agree"), with 1 subject reporting slight disagreement. All 10 subjects (100.0%) strongly agreed that listening in quiet was comfortable. Nine subjects (90.0%) agreed that listening in noise was comfortable (7 subjects reported "Strongly Agree," 2 subjects reported "Slightly Agree"), with 1 subject reporting slight disagreement.

All 10 subjects (100.0%) reported that AutoSense OS on the sound processor was acceptable for use and daily wear, with 8 subjects (80.0%) reporting strong agreement and 2 subjects (20.0%) reporting slight agreement with the statements "The sound processor is acceptable for use" and "The sound processor is acceptable for daily wear". The majority of subjects (80.0%) also agreed that AutoSense OS on the sound processor met their listening needs. The 2 subjects that slightly disagreed reported challenges in

noisy environments, although one of these subjects agreed that sound quality was acceptable and listening was comfortable in noise. These questionnaire results indicate that the sound processor is acceptable for use and satisfies users' listening needs.

In the United States, ClearVoice is approved for pediatric use in children 6 years and above who 1) are able to complete objective speech perception testing in order to determine speech performance and 2) are able to report a preference for different coding strategies or features.

ClearVoice is only available in markets where ClearVoice has received regulatory approval. Contact Advanced Bionics for more information.

COUNSELLING AND FITTING RECOMMENDATIONS:

- **WindBlock:** The intent of the WindBlock sound processing feature is to reduce wind noise arriving at the microphone to improve comfort and ease listening when listening in the presence of wind. This is an automatic feature that is enabled in the AutoSense program and can be enabled in other programs.
- **SoundRelax:** The intent of the SoundRelax sound processing feature is to quickly respond to sudden and/or unexpected sounds. This is an automatic feature that is enabled in the AutoSense program and can be enabled in other programs.
- **EchoBlock:** The intent of the EchoBlock sound processing feature is to improve comfort and ease of listening when listening in environments with a high degree of reverberation or echo. This is an automatic feature that is enabled in the AutoSense program and can be enabled in other programs.
- **UltraZoom:** The intent of the UltraZoom sound processing feature is to improve the signal to enhance listening when focused on a person speaking in front of you. In the AutoSense program, the feature will automatically enter or exit this mode depending on the surrounding noise in the environment. In other programs, UltraZoom can be enabled in a static mode.
- **StereoZoom:** The StereoZoom feature is designed only for use with bilateral recipients. The intent of this feature is to use a bilateral beamformer to create a narrow beam to focus on one person in front of you when in a noisy environment. This is an automatic feature that is enabled in the AutoSense program and can be enabled in other programs.
- **Real Ear Sound:** The intent of the Real Ear Sound sound processing feature is to simulate the natural sound quality of the T-Mic microphone. Real Ear Sound is active in quieter listening environments when the T-Mic microphone is not in use.
- **WhistleBlock:** The intent of the WhistleBlock sound processing feature is to minimize acoustic feedback that can occur when the M Acoustic Earhook is used with the Naída CI M90 sound processor. This is an automatic feature.
- **NoiseBlock:** The intent of the NoiseBlock sound processing feature is to improve comfort when listening in noisy environments. This is an automatic feature that is available when the M Acoustic Earhook is in use. It is enabled in the AutoSense program and can be enabled in other programs.

- AutoSense OS: The intent of the AutoSense program is to classify the listening environment and activate sound processing features based on the listening environment. The AutoSense program is enabled by default as the start-up program.

Cautions

- UltraZoom and StereoZoom are beamforming algorithms; therefore, by design they focus to the front and dampen sound from the side and back of the recipient.
- The Naída CI sound processor is designed so it can be worn in an off-ear wearing configuration. We do not recommend the processor be worn in the off-ear wearing configuration while using any beamforming algorithm.
- The intent of the WindBlock, EchoBlock, SoundRelax, and NoiseBlock algorithms is to attenuate a portion of the signal in order to provide comfort in specific environments. Attenuation of the signal may affect sound quality.

Note: In the United States, StereoZoom, auto UltraZoom, Sound Relax, WindBlock, and EchoBlock are approved for use in pediatric recipients 6 years and above who are 1) able to complete objective speech perception testing in order to determine speech performance and 2) are able to report a preference for different coding strategies or features.

www.advancedbionics.com/clinicalandsafetyperformance/

Users of the Naída CI M90 sound processor in the European Union should report any serious incident to their local competent authority.

GUIDELINES FOR IT SECURITY:

Intended Use Environment

The Naída CI M90 sound processor system is intended for use in healthcare and home environments. The home environment is extended to include use outdoors and during travel (e.g., airplanes). The Naída CI M90 sound processor system is intended to operate with the AB Remote application, the Phonak RemoteControl, the Target CI fitting software, and with any Bluetooth-enabled device used for audio streaming. The user is responsible for security of connections with other devices, including pairing the sound processor with other devices in a secure environment.

System and Network Diagram

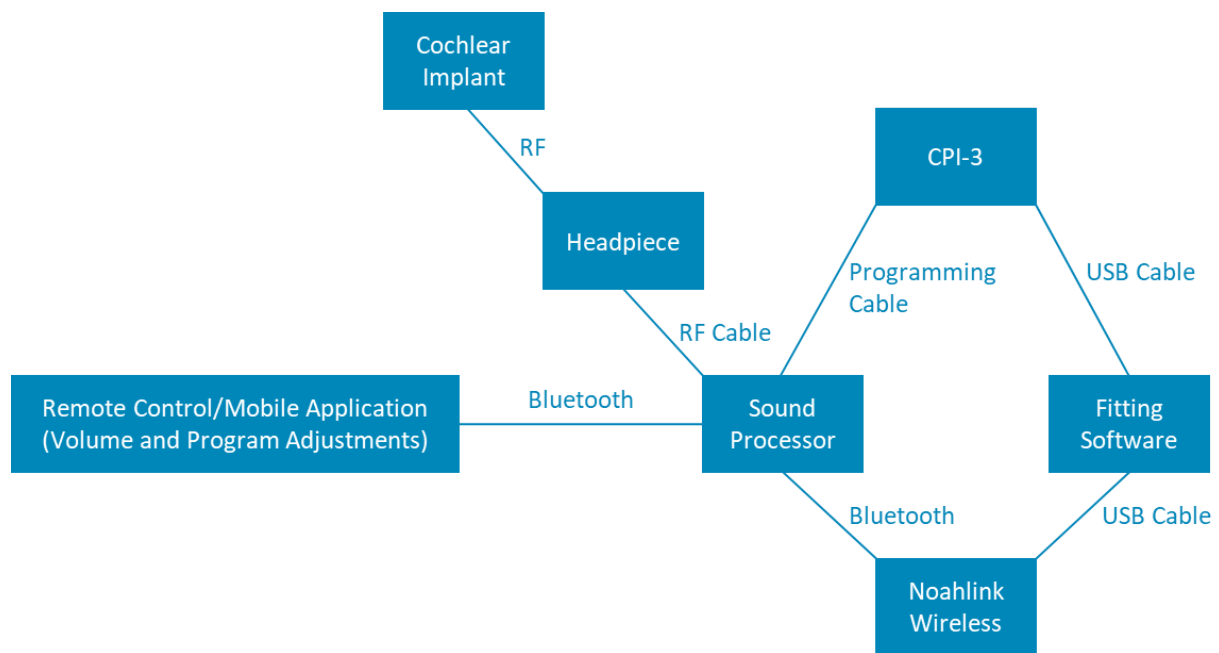

System Interfaces

| Component | Interface | Data Transfer Direction | Communication Protocol | Security |
|-----------------|-----------|-------------------------|---|--|
| Sound Processor | Bluetooth | Bidirectional | Bluetooth Classic: Hands-Free Profile with wideband speech option v1.6 (SPP v1.2, RFCOMM v1.2 over L2CAP) | Bluetooth Classic: E0 encryption Bluetooth LE: AES-CCM 128 encryption |

| | | | | |
|-------------------------|-----------|---------------|---|---|
| | | | Bluetooth Classic: Advanced Audio Distribution Profile v1.3 (AVDTP v1.3 over L2CAP) Bluetooth Classic: Audio/Video Remote Control Profile v1.5 (AVCTP v1.4 over L2CAP) | |
| Sound Processor | RF | Bidirectional | Advanced Bionics proprietary | None |
| Remote Control | Bluetooth | Bidirectional | Bluetooth LE: Proprietary GATT (Generic Attribute Profile) over L2CAP | Bluetooth LE: AES-CCM 128 encryption |
| Roger Devices | Roger DM | Bidirectional | Phonak proprietary | 32-bit code defining address and hopping sequence |
| TV Connector PartnerMic | Airstream | Bidirectional | Phonak proprietary | AES-CTR 128 encryption |

Cybersecurity Configuration

There is no specific Naída CI M90 sound processor configuration needed to help ensure cybersecurity. Ensure pairing with Bluetooth devices is completed in a secure environment.

Integrated Cybersecurity Functions

The Naída CI M90 system does not include user authorization or authentication mechanisms. The sound processor is configured to connect with a single Advanced Bionics cochlear implant when fit with the Target CI fitting software. All events are logged to an internal event log. Advanced Bionics can interpret and analyze the log if the device is returned. Data integrity and quality of service is ensured through sound processor and implant error correction and detection mechanisms.

System, Configuration, and Data Backup/Restore

The user should visit his or her cochlear implant professional if any unintended behavior of the sound processor is observed.

Cybersecurity Incident Response

The Naída CI M90 does not detect cybersecurity attacks or intrusions. In case of abnormal behavior of the sound processor, please visit your cochlear implant professional or contact Advanced Bionics.

Patches and Updates

Advanced Bionics does not patch the Naída CI M90 sound processor. Firmware updates may be made available from time to time and will require visiting your cochlear implant professional to reimage your sound processor. Authenticity of firmware can be verified by your cochlear implant professional using the Target CI fitting software.

Available Training

Users of the Naída CI M90 sound processor are trained by their cochlear implant professional at the initial fitting session.

End of Cybersecurity Support

Advanced Bionics products are supported until they no longer have regulatory approval in the country of use or until the product is obsolesced by Advanced Bionics.

GUIDANCE AND MANUFACTURER’S DECLARATION:

Per IEC 60601-1-2

Electromagnetic Emissions

| Emissions Test | Compliance | Electromagnetic Environment - Guidance |
|--|----------------|---|
| RF emissions CISPR 11 | Group 1 | The Naída CI M90 sound processor uses RF energy only for its internal function. Therefore, its RF emissions are very low and are not likely to cause any interference in nearby electronic equipment. |
| RF emissions CISPR 11 | Class B | The Naída CI M90 sound processor is suitable for use in all establishments, including domestic establishments and those directly connected to the public low-voltage power supply network that supplies buildings used for domestic purposes. |
| Harmonic emissions IEC 61000-3-2 | Not applicable | |
| Voltage fluctuations/flicker emissions IEC 61000-3-3 | Not applicable | |

Electromagnetic Immunity

The Naída CI M90 sound processor is intended for use in the electromagnetic environment specified below. The customer or the user of the Naída CI M90 sound processor should assure that it is used in such an environment.

| Immunity | IEC 60601 Test Level | Compliance Level ^a | Electromagnetic Environment - Guidance |
|---|---------------------------|-------------------------------|---|
| Electrostatic discharge (ESD) IEC 61000-4-2 | ± 6 kV contact ± 8 kV air | ± 6 kV contact ± 8 kV air | Floors should be wood, concrete or ceramic tile. If floors are covered with synthetic material, |

| | | | |
|--|------------------------------|-------|--|
| | | | the relative humidity should be at least 30%. As with the operation of other electronic devices, precaution should be taken to not generate ESD. |
| Power frequency (50/60 Hz) Magnetic Field IEC 61000-4-8 | 3 A/m | 3 A/m | Power frequency magnetic fields should be at levels characteristic of a typical location in a typical commercial or hospital environment. |
| Radiated RF IEC 61000-4-3 | 3 V/m 80 MHz to 2.5 GHz 3 | 3 V/m | Portable and mobile RF communications equipment should be used no closer to any part of the Naída CI, including cables, than the recommended separation distance calculated from the equation applicable to the frequency of the transmitter. Recommended separation distance: $d = 1.2\sqrt{P} < 800 \text{ MHz}$ $d = 2.3\sqrt{P} \geq 800 \text{ MHz}$ where P is the maximum output power rating of the transmitter in watts (W) according to the transmitter manufacturer and d is the recommended separation distance in meters (m). Field strengths from fixed RF transmitters, as determined by an electromagnetic site survey, ^b should be less than the compliance level in each frequency range. ^c Interference |

| | | | |
|--|--|--|---|
| | | | <p>may occur in the vicinity of equipment marked with the following symbol:</p>  |
|--|--|--|---|

Note 1: These guidelines may not apply in all situations. Electromagnetic propagation is affected by absorption and reflection from structures, objects, and people.

- a. Essential performance of the Naída CI per IEC 60601 requirements is defined as auditory stimulation within safe amplitudes.
- b. Field strengths from fixed transmitters, such as base stations for radio (cellular/cordless) telephones and land mobile radios, amateur radio, AM and FM radio broadcast, and TV broadcast cannot be predicted theoretically with accuracy. To assess the electromagnetic environment due to fixed RF transmitters, an electromagnetic site survey should be considered. If the measured field strength in the location in which the Naída CI is used exceeds the applicable RF compliance level above, the Naída CI should be observed to verify normal operation.
- c. Over the frequency range 150 kHz to 80 MHz, field strengths should be less than 3 V/m.

Separation Distances between RF Communications Equipment and Naída CI M90

Recommended Separation Distances between Portable and Mobile RF Communications Equipment and the Naída CI M90

The Naída CI is intended for use in an electromagnetic environment in which radiated RF disturbances are controlled. The customer or the user of the Naída CI can help prevent electromagnetic interference by maintaining a minimum distance between portable and mobile RF communications equipment (transmitters) and the Naída CI as recommended below, according to the maximum output power of the communications equipment.

| Rated Maximum Output Power of Transmitter (w) | Separation distance according to frequency of transmitter (m) | |
|---|---|---------------------|
| | d = 1.2√P < 800 MHz | d = 2.3√P ≥ 800 MHz |
| 0.01 | 0.12 | 0.23 |
| 0.1 | 0.38 | 0.73 |
| 1 | 1.2 | 2.3 |
| 10 | 3.8 | 7.3 |
| 100 | 12 | 23 |

For transmitters rated at a maximum output power not listed above, the recommended separation distance d in meters (m) can be estimated using the equation applicable to the frequency of the transmitter, where P is the maximum output power rating of the transmitter in watts (W) according to the transmitter manufacturer.

Note 1: These guidelines may not apply in all situations. Electromagnetic propagation is affected by absorption and reflection from structures, objects and people.

This instrument is certified under:

- FCC ID: 2AU60-ABBTE2
- IC: 25853-ABBTE2

This device complies with Part 15 of the FCC Rules and with RSS-210 of Industry Canada. Operation is subject to the following two conditions:

1. This device may not cause harmful interference, and
2. This device must accept any interference received, including interference that may cause undesired operation.

Changes or modifications made to this equipment not expressly approved by Advanced Bionics may void the FCC authorization to operate this equipment. This Class B digital apparatus complies with Canadian ICES-003.

This equipment has been tested and found to comply with the limits for a Class B digital device, pursuant to Part 15 of the FCC Rules. These limits are designed to provide reasonable protection against harmful interference in a residential installation. This equipment generates, uses, and can radiate radio frequency energy and, if not installed and used in accordance with the instructions, may cause harmful interference to radio communications. However, there is no guarantee that interference will not occur in a particular installation.

This equipment complies with FCC and ICED radiation exposure limits set forth for an uncontrolled environment. This transmitter must not be co-located or operating in conjunction with any other antenna or transmitter. This device has been evaluated in compliance with portable exposure condition.

If this equipment does cause harmful interference to radio or television reception, which can be determined by turning the equipment off and on, the user is encouraged to try to correct the interference by one or more of the following measures:

- Reorient or relocate the receiving antenna.
- Increase the separation between the equipment and receiver.
- Connect the equipment into an outlet on a circuit different from that to which the receiver is connected.
- Consult your cochlear implant professional or an experienced radio/TV technician for help.

Cet appareil est conforme à la partie 15 des règlements de la FCC et à la norme RSS-210 d'Industrie Canada. Son fonctionnement est soumis aux deux conditions suivantes :

1. cet appareil ne doit pas provoquer d'interférences nuisibles, et

2. cet appareil doit accepter les interférences reçues, y compris les interférences pouvant entraîner un fonctionnement indésirable.

Tous changements ou modifications apportés à cet appareil qui n'ont pas été approuvés par Advanced Bionics peuvent annuler l'autorisation d'utilisation de cet appareil de la FCC. Cet appareil numérique de classe B est conforme à la norme ICES-003 du Canada.

Cet appareil a été testé et déclaré conforme aux limites d'un appareil numérique de classe B, en vertu de la partie 15 des règlements de la FCC. Ces limites sont conçues pour fournir une protection raisonnable contre les interférences nuisibles dans une installation résidentielle. Cet appareil produit, utilise et peut émettre de l'énergie de fréquence radio et, s'il n'est pas installé et utilisé conformément aux directives, peut causer des interférences nuisibles aux communications radio. Il n'y a cependant aucune garantie que des interférences ne se produiront pas dans une installation particulière.

Cet appareil est conforme aux limites d'exposition aux rayonnements de la FCC et de l'ISED établies pour un environnement non contrôlé. Cet émetteur ne doit pas être situé ou utilisé à proximité d'une antenne ou d'un autre émetteur. Cet appareil a été déclaré conforme aux limites d'exposition pour les appareils portables.

Si cet appareil cause des interférences nuisibles à la réception des signaux de radio ou de télévision, ce qui peut être déterminé en allumant et en éteignant l'appareil, l'utilisateur est encouragé à tenter de corriger ces interférences en prenant une ou plusieurs des mesures suivantes :

- Réorienter ou repositionner l'antenne de réception.
- Augmenter la distance entre l'appareil et le récepteur.
- Brancher l'appareil sur un circuit électrique différent de celui où le récepteur est branché.
- Consulter votre professionnel de l'implant cochléaire ou un technicien spécialisé en radio/télévision pour obtenir de l'aide.

© 2020 Advanced Bionics LLC. All Rights Reserved.