



VO8438 -Antenna report for VO8438

Summary

VO8438 -Antenna report for VO8438	1
1. Antenna references.....	2
2. Electrical Characteristics	2
3. Matching circuit.....	3
4. SWR & Smith chart	4
5. Gain	5
6. Radiation Diagram.....	6



1. Antenna references

Antenna model : 209940A – ACC1300BI

Antenna designation : ANT FIL81mm YELLO SILI-1V 0.15 0.15mm2 TIN-PLATE 3mm/ 1side

Antenna manufacturer : SOCIETE NOUVELLE ISEROISE

Antenna manufacturer address : 131 Rue du Vercors - ZA de Malvaisin - 38420 - LE VERSOUD -France

2. Electrical Characteristics

Item	Specification
Type	Lambda/4 wire antenna
Central frequency	880
Bandwidth	140MHz
Gain	0dBi
Polarization	Linear
VSWR	3 max
Azimuth Bandwith	Omni-directional
Impedance	custom
Rated Power (max.)	30dBm
Maximum Input Power	30dBm
Operation Temperature	-40' C ~ +85' C

3. Matching circuit

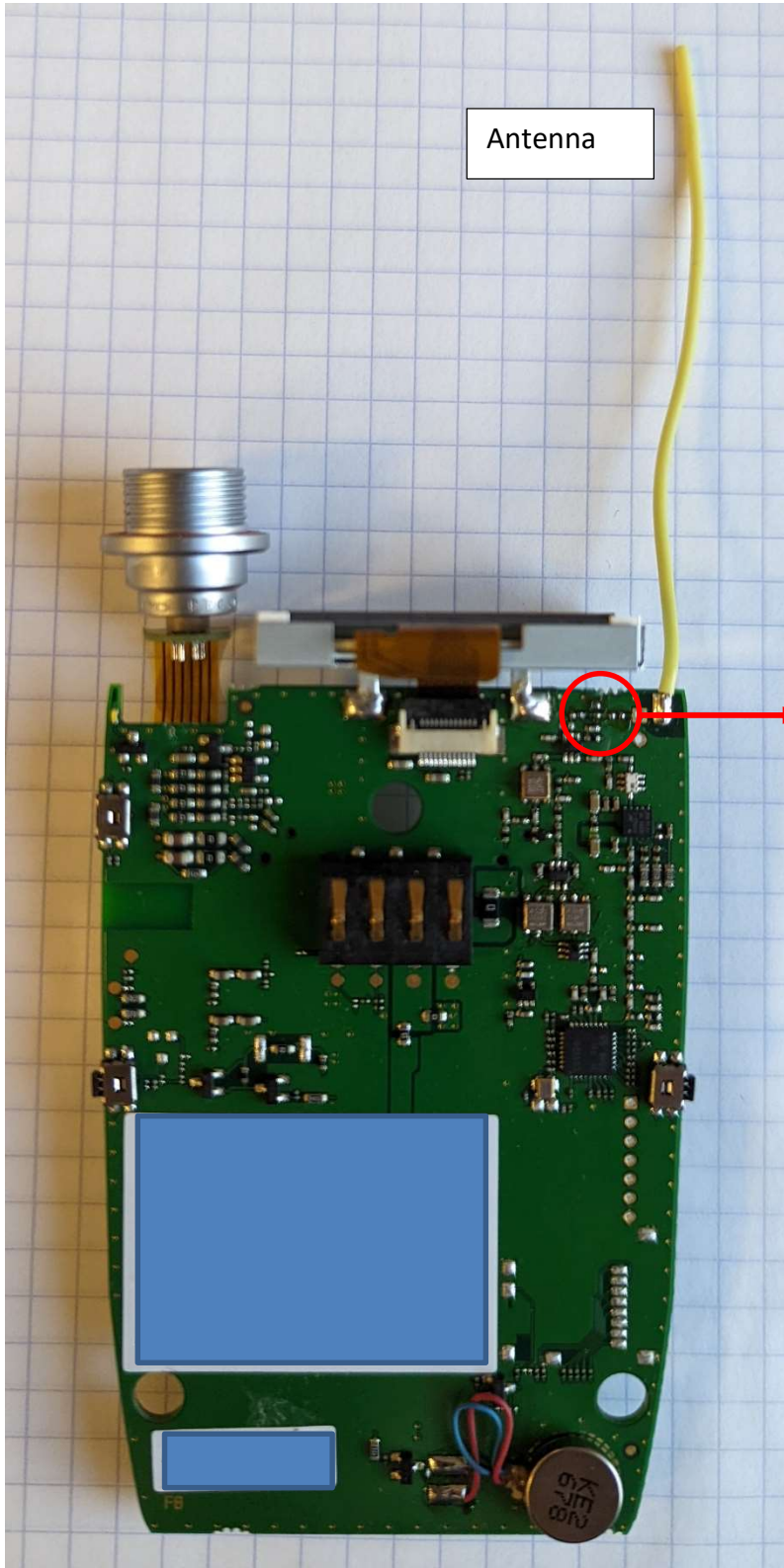

Antenna

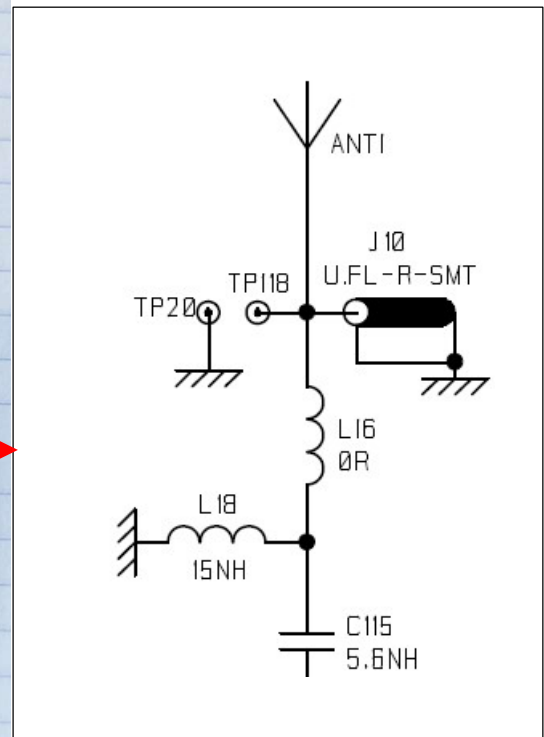



4. SWR & Smith chart

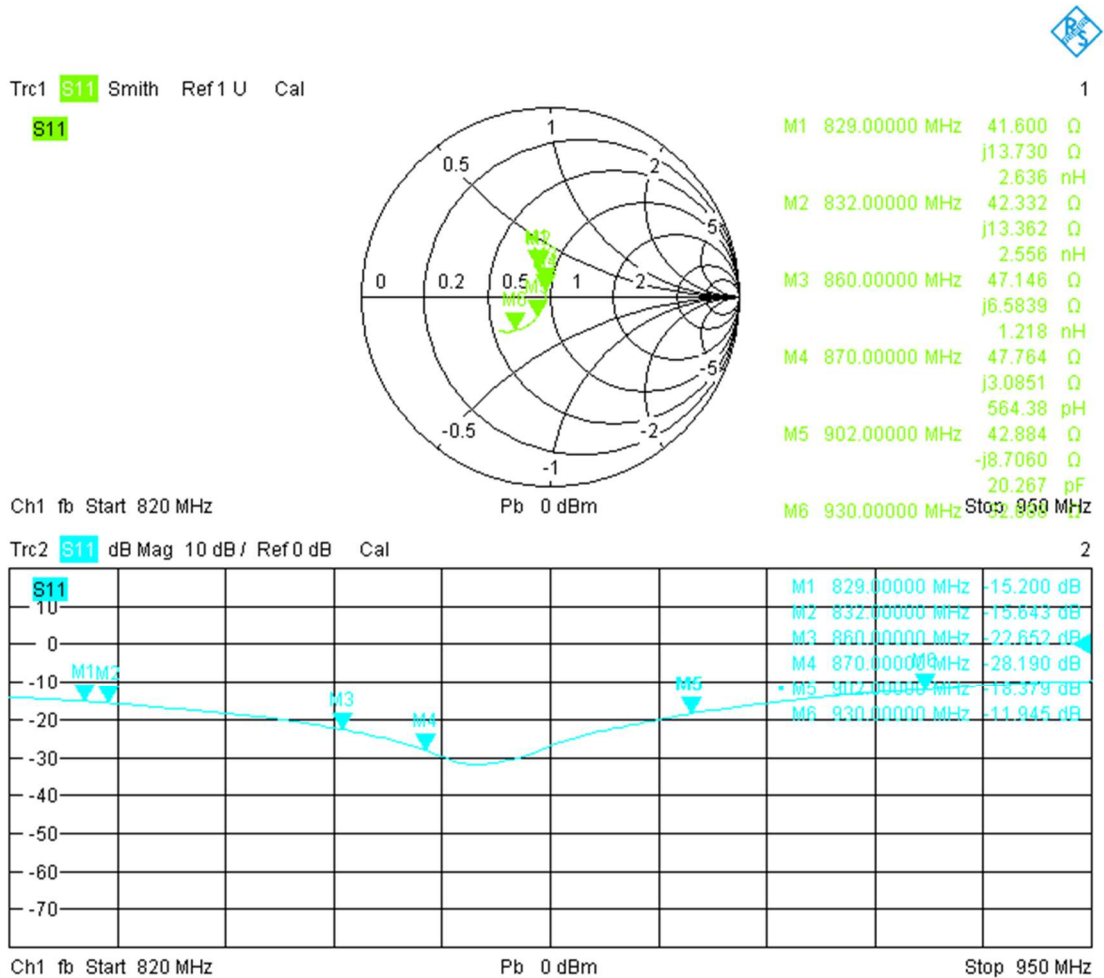

10/12/2022, 3:23 PM



5. Gain

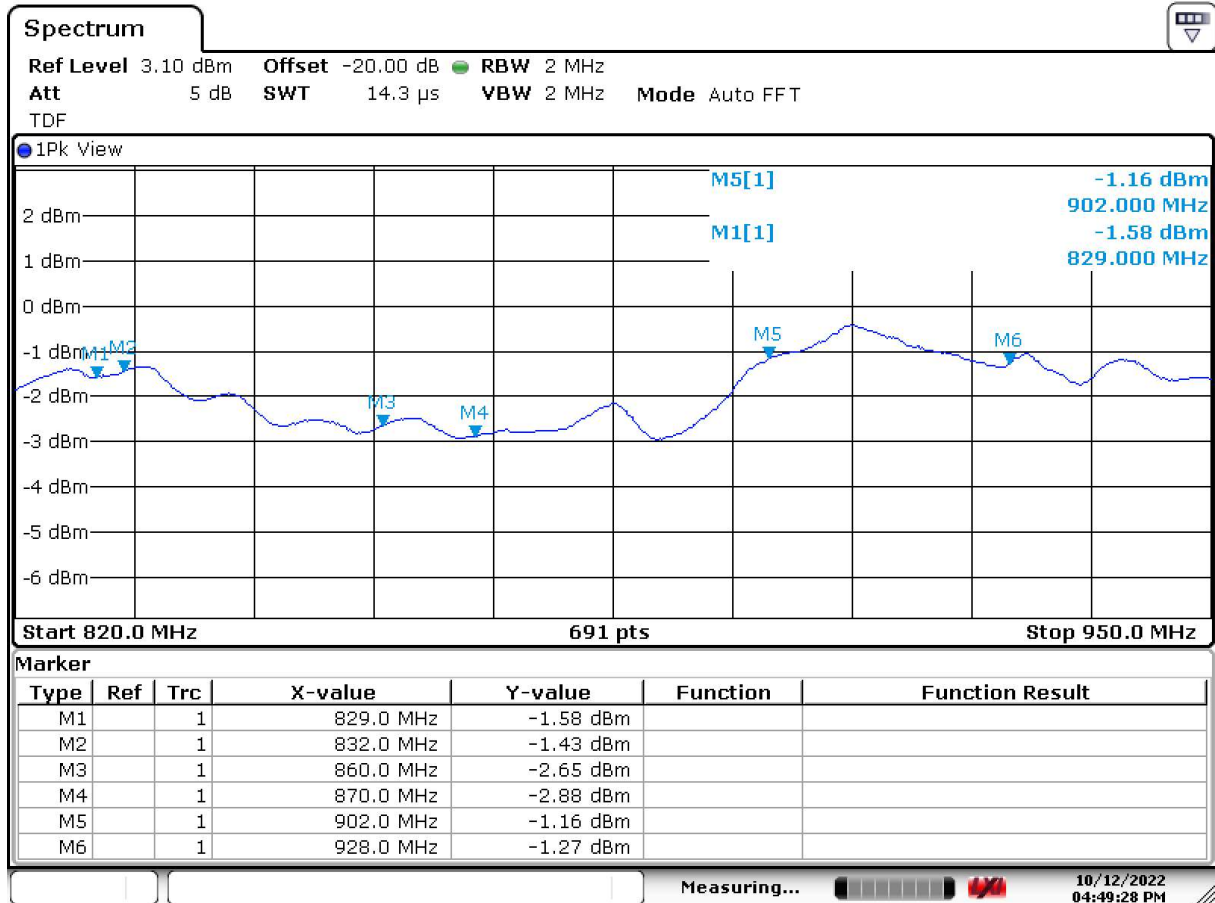

Date: 12.OCT.2022 16:49:29



6. Radiation Diagram

Done with an emitted radiated power (EIRP) of 20dBm

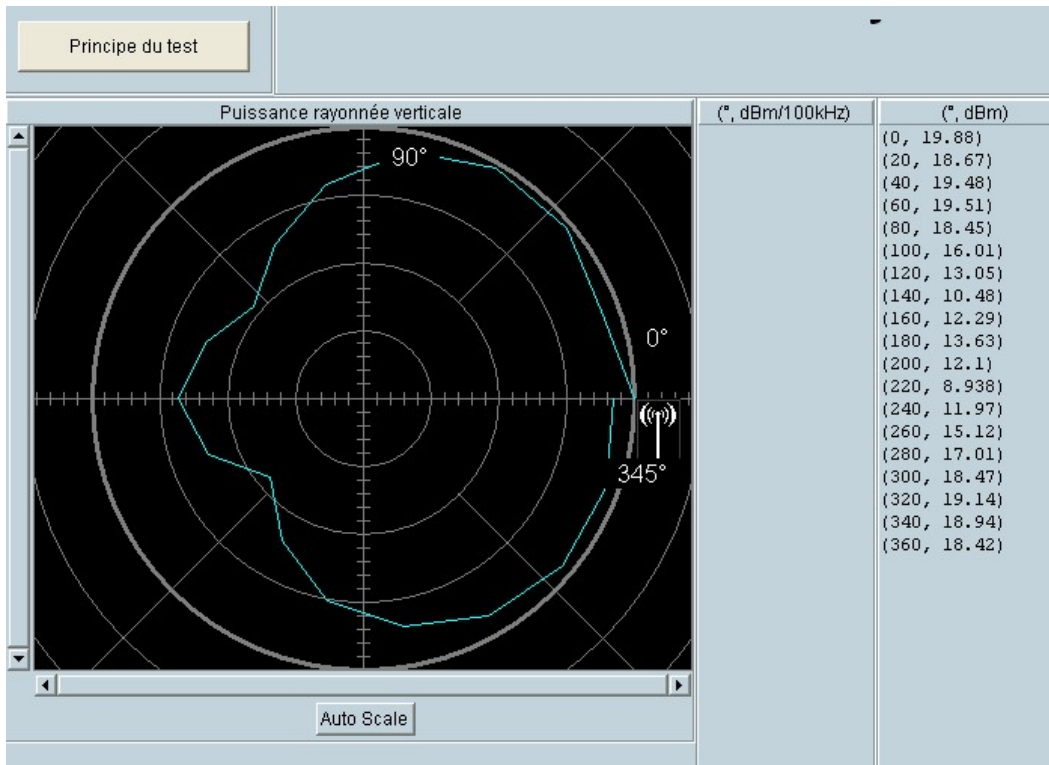

Figure 1 : EIRP for V Polarization – Product Vertical

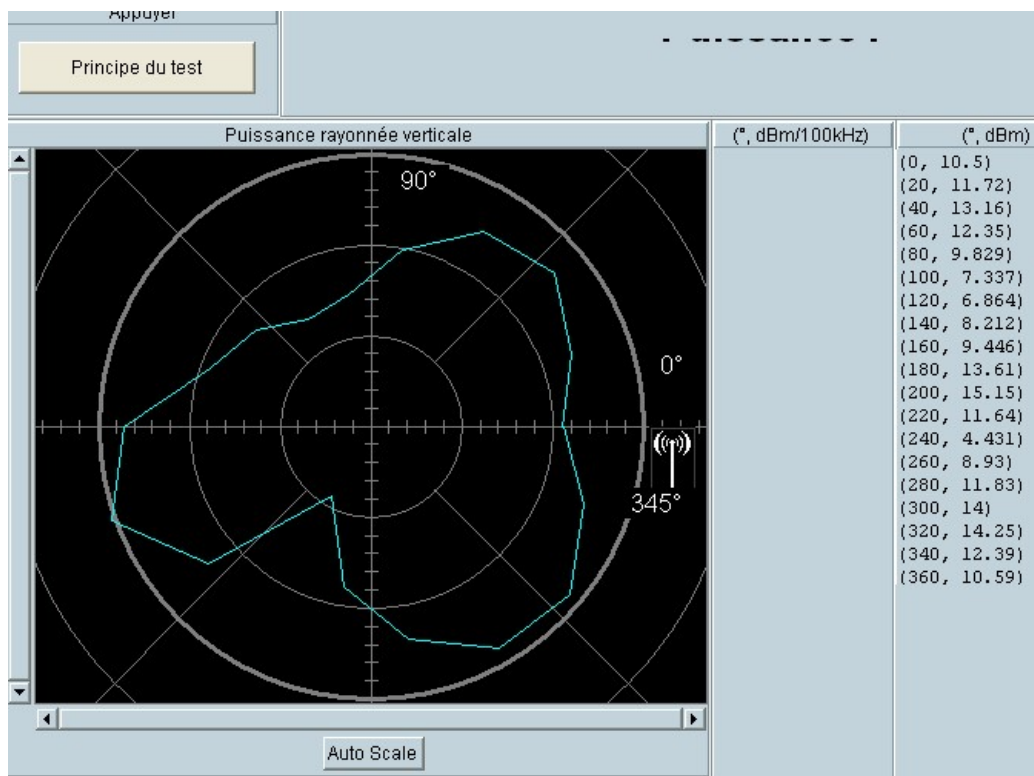

Figure 2 : EIRP for V Polarization – Product Horizontal

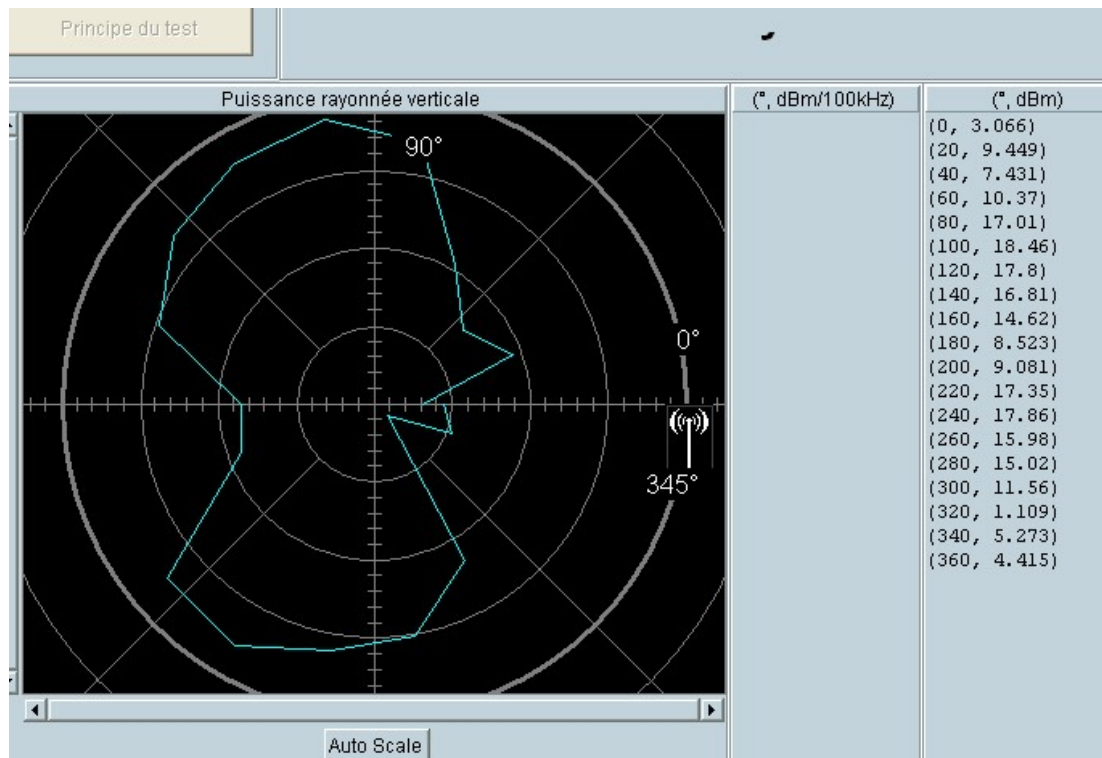

Figure 3 : EIRP for H Polarization – Product Horizontal

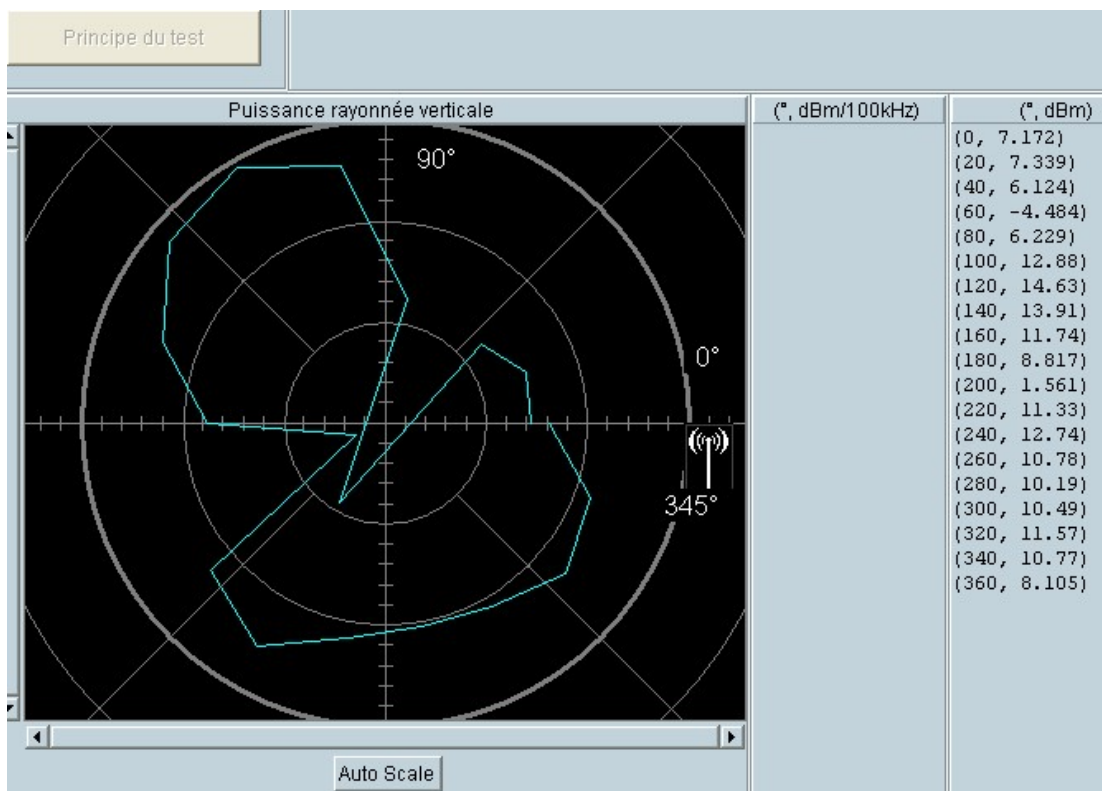

Figure 4 : EIRP for H Polarization – Product Vertical

End of the Report