

承 認 書

SPECIFICATION FOR APPROVAL

客 戶: CUSTOMER:	安信微
客 戶 料 號: CUST P/N:	W12
松 島 料 號: FINE P/N:	G43-6.5uH 单线圈 0.08*24*2P*10TS
產 品 型 號: DESC:	Φ 43.5MMX5.0MMX0.7MM
日 期: DATE:	2023/05/09
版 本: Version:	A.0

擬 制 PREPARED BY	審 核 CHECKED BY	批 准 APPROVED BY	客 戶 承 認 CUSTOMER APPROVE
黄燕铭	宁元安	黄锦华	

深圳市松岛科技有限公司 Shenzhen Songdao Technology Co., Ltd

工廠地址：东莞市东坑镇骏发三路 123 号三甲高新技术产业园 2 栋 8 楼
Factory address: 8th Floor, Building 2, Sanjia High-tech Industrial Park, No.123 Junfa Third Road, Dongkeng Town, Dongguan City

TEL: 13728755750

FAX: 0755-84526500

E-mail: 506388681@qq.com

SPECIFICATION

產品型號: DESC	Φ 20.5x38.5-6.5uH-0.08x24X2P-30mm-43 .5C	版本 Rev: A.0	客戶 CUST: 客戶料号 CUST P/N:	XXX
---------------	---	----------------	----------------------------	------------

一、尺寸 DIMENSION:(mm)

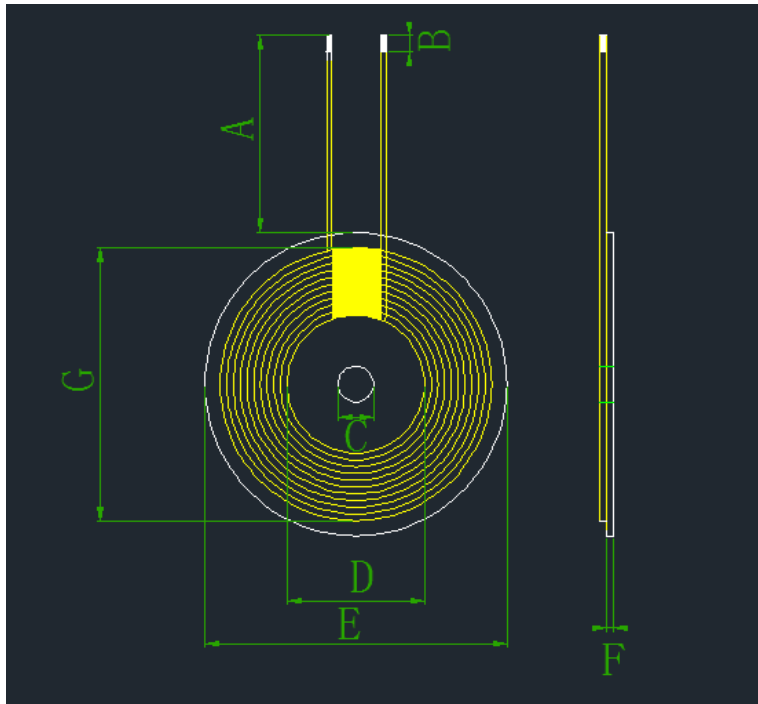

A	35±2
B	4±2
C	5.3±0.5
D	20.5±0.5
E	43±0.5
F	0.8±0.2
G	38.5±0.5

- 注:
- 1.交叉出线;
 - 2.出线位置缠 8mm(ref)宽度高温胶纸 1-2Ts;
 - 3.线圈贴圆形硬磁片, 磁片尺寸 43±0.5mm,内孔 5.3mm,厚度为 0.8±0.2mm。

二、原理图 SCHEMATIC DIAGRAM:

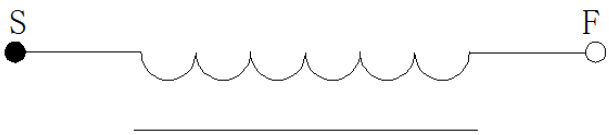

三、绕线参数 Winding Specification:

序号 NO.	端子 TERMINAL		线径 WIRE	圈数 Turns	绕线方向 Winding Direction
1	S	F	自粘漆包线 0.08*24*2 P	10Ts	CCW

四、电气特性 ELECTRICAL CHARACTERISTICS:

温度 TEMPERATURE:25±10 ℃, 湿度 RELATIVE HUMIDITY:65±20%

序号 NO.	项目 ITEM	端子 TERMINAL	标准 SPECIFICATION	测试条件 TEST FREQUENCY	测试仪器 TEST EQUIPMENTS
1	IND.	S-F	4.0uH ±10%单独线圈	100KHz/0.25V	LCZ METER 1062B
2	IND.	S-F	6.5uH ±10%加磁片	100KHz/0.25V	LCZ METER 1062B
3	DCR	S-F	≤85mΩ	100KHz/0.25V	LCZ METER 502B
4	Q 值	S-F	≥33	100KHz/0.25V	LCZ METER 502B

编制/日期 PREPARED BY/DATE 黄燕铭 2023/05/09	审核/日期 CHECKED BY/DATE 黄锦华 2023/05/09
--	---