

User Manual

XORAYA N4000+



© 2022 X2E GmbH

This user manual is copyrighted; all customary rights reserved.
Reproduction of this manual, even in part, is only allowed with permission
of X2E GmbH. Offenders shall be liable to pay compensation and may be
subject to prosecution.

All product names and trademarks used in this manual are the property of
their respective owners.

X2E GmbH
Grosse Ahlmühle 19
76865 Rohrbach
GERMANY

Phone: +49 6349 99599 200
E-Mail: xoraya@x2e.de
Internet: www.x2e.de
Wiki: wiki.x2e.de

Table of contents

1	Introduction.....	5
1.1	About this user manual	5
1.2	Validity of the user manual	6
1.3	Representation conventions	6
1.4	Pictograms	7
1.5	X2E-Wiki.....	8
2	Safety and warranty.....	9
2.1	Intended use	9
2.2	Safety label on the device.....	10
2.3	General safety instructions	10
2.4	Product liability	13
2.5	Terms of use.....	13
2.6	Warranty	13
3	Product description.....	15
3.1	Identification.....	16
3.2	Scope of delivery.....	17
3.3	Connections and controls.....	18
4	Commissioning.....	25
4.1	Unpacking.....	25
4.2	Selecting an installation location	25
4.3	Installing the N4000+	25
4.4	Installing the XORAYASuite	26
4.5	Connecting the N4000+ to the measuring environment.....	27
4.6	Connecting the N4000+ to the PC	30
4.7	Configuring switches	31
5	XORAYASuite.....	32
5.1	Starting	32
5.2	Menu bar	33
5.3	Status bar	36
5.4	Connecting and disconnecting the N4000+	37
5.5	Configuration.....	40
5.6	Resetting to factory defaults	109
5.7	Data recording	110
5.8	Hdd-Download	118
5.9	Viewer.....	124
5.10	Statistic.....	143
5.11	Convert.....	145
5.12	Firmware-Update.....	148
5.13	TK Commandline	150
5.14	Common elements	152
6	Maintenance	166
6.1	Safety measures	166
6.2	Cleaning	167

6.3	Repair	168
7	Storage, transport and disposal	169
7.1	Storage	169
7.2	Transport	169
7.3	Disposal	169
8	Appendix.....	170
8.1	Technical data.....	170
8.2	N4000+ pin assignments	171
8.3	Output formats	178

1 Introduction

1.1 About this user manual

- ▶ Read this user manual completely before using the XORAYA N4000+ for the first time.
- ▶ Please consider this user manual as part of the product and make sure it is easily accessible.
- ▶ Provide this user manual upon transfer of the N4000+ to a third party.
- ▶ Request a replacement user manual upon loss.

This user manual contains important information for safe, proper and efficient operation of the N4000+. Following this user manual strictly helps in avoiding dangers, reduces repair costs and downtime, while increasing the reliability and service life of the N4000+. It should be read, understood and applied by those using the N4000+ according to the user manual.

Pay particular attention to:

- the safety section (→ Safety and warranty)
- the text warnings of each section

Bear in mind that this user manual does not replace your responsibility as a N4000+ user.

Subject to change without prior notice. This applies especially to changes relating to technical enhancements.

1.2 Validity of the user manual

This user manual applies to X2E’s dataloggers of the XORAYA N4000+ series. The exact type specifications can be found on the nameplate.
(→ Identification)

The following instructions are key to operate the N4000+ and must be strictly observed under all circumstances.

Information in this user manual is subject to change without prior notice due to further technical developments and subsequent modifications. New features may not be described yet or may be described incompletely. Please ensure that you have the most current and complete user manual.

Users can change certain properties and functions via the included software, so that the N4000+ behaves differently than described herein. Users may revert to factory defaults at any time by pressing the default button on the front panel or via the supplied software. (→ Resetting to factory defaults)

1.3 Representation conventions

Representation	Meaning
▶ <Instruction>	User-executed action
▶ <Instruction option 1> <i>or</i> ▶ <Instruction option 2>	Instruction options
☑ <Outcome>	Outcome of an action or a series thereof
▪ <Level 1 a> – <Level 2 a> – <Level 2 b> ▪ <Level 1 b>	Maximum two-level enumeration
→ <Cross-reference>	Clickable cross-reference to a section or heading (In most Windows programs, you can return to the previous position by pressing <i>ALT + Left arrow</i>)
<Text>	Housing label, GUI element or other highlighting
#	Placeholder for numbers
(1) or (A)	Reference to numbered markers in graphics

1.4 Pictograms

This manual uses pictograms to highlight and ensure faster recognition of important or especially useful information.

Warning:



This type of symbols indicate warnings which must be observed.

The following subsections contain a description of the basic structure and relevance of different warning levels.

General information:



This symbol indicates general information.

General information includes application tips and particularly useful information excluding warnings or hazards.

Licence information:



This symbol indicates licence information.

Licence information contains either general information about licences for the N4000+ or indicates whether a licence is required for a particular function.

1.4.1 Meaning of warnings

Warnings are systematised according to the severity and probability of their occurrence.



CAUTION

This pictogram in conjunction with the word *Caution* warns of a potentially dangerous situation, or an unsafe procedure.

Ignoring this warning information could result in injury or property and environmental damage.



WARNING

This pictogram used in conjunction with the word *Warning* warns of a potentially imminent danger to the health and lives of people.

Ignoring this warning could cause serious personal injury, including death in the worst case.



DANGER

This pictogram used in conjunction with the word *Danger* warns of an imminent danger to the health and life of people.

Ignoring this warning causes serious personal injury, including death in the worst case.

1.4.2 Structure of warnings

Warnings are separated from the surrounding text by lines set above and below.



SIGNAL
WORD

Danger types and sources

Explanation and consequence of danger

- ▶ Actions to prevent danger

1.5 X2E-Wiki

The X2E-Wiki at <http://wiki.x2e.de> provides the following information:

- Latest software
- Latest firmware
- Latest licence file

For access details, please send an email stating your contact data to wiki@x2e.de. We will send you the appropriate access data. You may request your access details at any time if necessary.

2 Safety and warranty

The XORAYA N4000+ dataloggers were developed according to the latest state of the art and offer outstanding safety levels. During operation, however, this safety level can only be achieved if the user complies with all relevant safety regulations.

Upon measuring, safety regulations of the professional associations must be observed.

Please contact an expert or the service of X2E GmbH when in doubt about the operation, safety, or connection of the N4000+.

2.1 Intended use

The N4000+ is used for real-time acquisition of data communication in automotive bus systems. You can perform, store and transfer measurements to a PC, where you can read and analyse them using the GUI of the XORAYASuite.

- The N4000+ is intended for use only by trained personnel.
- The N4000+ must not be used in residential or living areas. Its use is strictly limited to industrial environments.
- The N4000+ must also not be used in outdoor areas or hazardous areas.
- Always operate the N4000+ within its technical specifications. (→ Technical data)
- The N4000+ may only be used under the conditions and for the purposes for which it was designed.
- Repairs may only be carried out by trained personnel of X2E GmbH.
- Operational safety cannot be guaranteed after modifications or conversions.
- Except for data buses, never perform measurements on live parts.
- The 4-mm plug of the power supply cable delivered must never be introduced in low-voltage sockets.
- The data lines may be extended up to a maximum of 30 m (USB: 3 m, eSATA: 1 m) provided that they are shielded like the supplied cables.
- The voltage supply may be extended up to a maximum of 3 m with sufficient cross-section.

2.2 Safety label on the device

You find the following safety label on the N4000+ top side:



Burning hazard due to hot surfaces

Continuous operation can strongly heat up the N4000+. As a result, it can burn the skin on the hands when touching it.

- ▶ Wear temperature-resistant ESD gloves when in contact with the N4000+.

2.3 General safety instructions



DANGER

Electric shock caused by damage to components

Any damage to the N4000+, power source or connection cable may cause an electric shock.

- ▶ Switch on the N4000+ only if all components appear undamaged.
- ▶ Only commission the N4000+ after a proper installation or repair.
- ▶ Check the connecting cable regularly for defects to prevent damage to the power source.
- ▶ Always install the N4000+ in de-energised status.



WARNING

Defects influencing the environment

The incorrect N4000+ configuration can lead to the temporary or permanent functional failure of connected vehicles.

Connected vehicles being operated on public roads bear an increased risk of injury and damage.

- ▶ If available, use configuration templates provided by the vehicle manufacturer.
- ▶ Use preferably the passive recording modes of the interfaces.



CAUTION

Device damage due to short circuit

Bent connector pins pose a short circuit risk. This can lead to abnormal behaviour or destruction of the N4000+.

Likewise, devices connected to the measurement setup may be also compromised.

- ▶ Make sure that connector pins are not bent.
- ▶ Check the N4000+ regularly for any deficiencies.



CAUTION

Device damage due to electrostatic discharge

Electronic components can be destroyed by electrostatic discharge.

- ▶ Avoid touching connectors and connector pins.
- ▶ Ground yourself before carrying the N4000+ in your hands.
- ▶ Operate the N4000+ in an ESD-compliant environment.



CAUTION

Device damage due to overheating

Overheating can lead to abnormal behaviour or destruction of the N4000+.

- ▶ Do not operate the N4000+ outside the specified temperature range.
- ▶ Never operate the N4000+ near heat sources.
- ▶ Please ensure adequate air circulation for operation.
- ▶ Do not cover the N4000+ with other objects.



CAUTION

Device damage due to shocks

Excessive vibration can lead to abnormal behaviour or destruction of the N4000+.

- ▶ Avoid exposing the N4000+ to excessive vibration.



CAUTION

Device damage due to pollution

Avoid any contamination in plugs and sockets to ensure a reliable contact.

- ▶ Keep the N4000+ clean.



CAUTION

Device damage due to device opening

Unauthorised opening of the N4000+ can lead to abnormal behaviour or destruction of the device.

- ▶ Never open the N4000+.
 - ▶ Contact X2E GmbH should maintenance and repairs be required.
-



CAUTION

Device damage due to penetration of dust or liquids

Dust or moisture inside the N4000+ may cause abnormal behaviour or destruction of the device.

- ▶ Only operate the N4000+ with a closed housing.
- ▶ Do not operate the N4000+ outdoors.
- ▶ Do not operate the N4000+ outside the specified temperature range.
- ▶ Turn off the N4000+ and disconnect it from the power supply before you start cleaning.



CAUTION

Damage due to improper device shutdown

Disconnecting the power supply during operation may cause data loss and destruction of the N4000+.

- ▶ Never disconnect the N4000+ from the power supply while in operation.
- ▶ Ensure proper connector seating and tighten the screws if possible.
- ▶ Only shut down the N4000+ through the XORAYASuite or the power button on the front panel.
- ▶ Pull the black plug connected to ground last when disconnecting the N4000+ from the power supply.



CAUTION

Safety defects due to incorrect accessories and spare parts

Accessories and spare parts that have not been recommended by X2E GmbH negatively affect the safety, functionality and precision of the N4000+.

X2E GmbH shall assume no responsibility whatsoever or honour any warranty for damages arising from non-recommended accessories and spare parts or incorrect use.

- ▶ Use only accessories recommended by X2E GmbH and original spare parts.

2.4 Product liability

In the following cases, the intended protection of the N4000+ may be adversely affected. The liability is then transferred to the user.

- The N4000+ is not used according to the manual.
- The N4000+ is used outside the scope described in this manual.
- The user modifies the N4000+ without proper authorisation.

2.5 Terms of use

If the installation of the N4000+ in a vehicle is intended for operation on public roads, the user and the X2E GmbH must jointly perform a risk analysis beforehand. This analysis must take into account the specific installation requirements and the valid factory standards at the user's site.

Conditions set forth in framework contracts shall apply.

The N4000+ is continuously developed. The development process relies on the cooperation between the user and X2E GmbH.

2.6 Warranty

The warranty period is 12 months. Device batteries, whether internal or external, are excluded from the warranty. The warranty also excludes damages arising from improper handling.

X2E GmbH guarantees that the media on which the software is located are free of material errors under normal operating conditions. Users can return any defective or materially erroneous media to X2E GmbH within a period of 30 days from date of original purchase. Media shall be replaced immediately at no cost.

X2E GmbH guarantees that the software as described herein is basically usable. X2E GmbH, however, shall assume no liability for the correctness and the continued use of the software, given that the current state of the art prevents the production of software suitable for all combinations of hardware and software.

In particular, X2E GmbH cannot guarantee that the software meets any user requirements, or that it is compatible with any programs the latter may have selected. Responsibility for program selection and the consequences of program use lie entirely with the user.

X2E GmbH shall assume no liability for damages arising from faulty recorded data, as well as damage due to incorrect configuration, data entry and data transfer.

After configuring, we recommend to verify the proper operation and plausibility of each sensor using some manual measurement over the entire measuring range.

X2E GmbH shall assume no further liability. This limitation of liability also applies to the personal liability of employees, representatives and organs of X2E GmbH.

2.7 FCC notice

This equipment has been tested and found to comply with the limits for a Class A digital device, pursuant to part 15 of the FCC Rules. These limits are designed to provide reasonable protection against harmful interference when the equipment is operated in a commercial environment. This equipment generates, uses, and can radiate radio frequency energy and, if not installed and used in accordance with the instruction manual, may cause harmful interference to radio communications. Operation of this equipment in a residential area is likely to cause harmful interference in which case the user will be required to correct the interference at his own expense.

Changes or modifications made to this equipment not expressly approved by X2E GmbH may void the FCC authorization to operate this equipment.

3 Product description

The XORAYA dataloggers are processor-controlled storage units, designed to record data from several and different data sources simultaneously. These dataloggers are indeed unique in the automotive industry thanks to their central 100-ns timestamp on all interfaces. Furthermore, its modular design allows for a rapid and flexible adjustment to future demands. This is stressed by the fact that all product phases, i.e. from design and development to programming and production, are completed in-house.

The dataloggers can be equipped with many different interfaces:

- Lowspeed-CAN, Highspeed-CAN and CAN-FD
- FlexRay
- LIN
- RS-232
- PSI5
- Analog
- BroadR-Reach
- MOST25 and MOST150
- Ethernet 100Base-T and 1000Base-T
- GNLog and DLT via Ethernet and RS-232
- CCP and XCP
- GPS

The N4000+, based on the Xilinx Zynq® UltraScale+™ MPSoC, is the new generation of the XORAYA datalogger. The built-in supercapacitor unit is able to bridge power fluctuations and to shut the N4000+ down safely in case of power failures.

Data can be directly saved to the storage medium (internally or externally) or to a computer system via Ethernet interface. Both modes can also be operated in parallel.

Operation can be managed via the graphical user interface XORAYASuite, whereby the N4000+ can be configured, and data recorded and downloaded from the N4000+. Moreover, you can evaluate the recorded data and export them to many popular formats.

3.1 Identification

The bottom side of the N4000+ bears a silver nameplate, which contains the following information:



- **Type** Product variant
- **Config.** First block: Product ID
 0200 XORAYA Datalogger
 Second block: Product variant
 0720 XORAYA N4000+
 Third block: Hardware revision
- **Input** Maximum current consumption at given standard input voltage
- **S/N** Unique serial number for this N4000+
- **DMF** Date of manufacture

Upon device-specific issues, always provide the serial number and configuration.

The interface configuration of a N4000+ is variable and, therefore, not recorded on the nameplate.

3.2 Scope of delivery

The following components are part of the delivery:

- XORAYA N4000+ with impact protection
- Power supply cable
- Software
- User manual
- Cable set, depending on the interface configuration

The following accessories are optionally available:

- Power supply cable with AC adapter (recommended)
- XORAYA External Storage Unit
- Additional cables
- Mounting material
- Device bag

Additionally, we recommend the following third-party accessories:

- USB 3.1 standard cable, screwable, 1 m, from IDS (item number AD00223)
- SFP+ module FTLX8573D3BTL from Finisar

3.3 Connections and controls

The front side of the N4000+ contains ports, buttons and LEDs for operation and elementary functions.

The back side of the N4000+ contains the log interfaces.

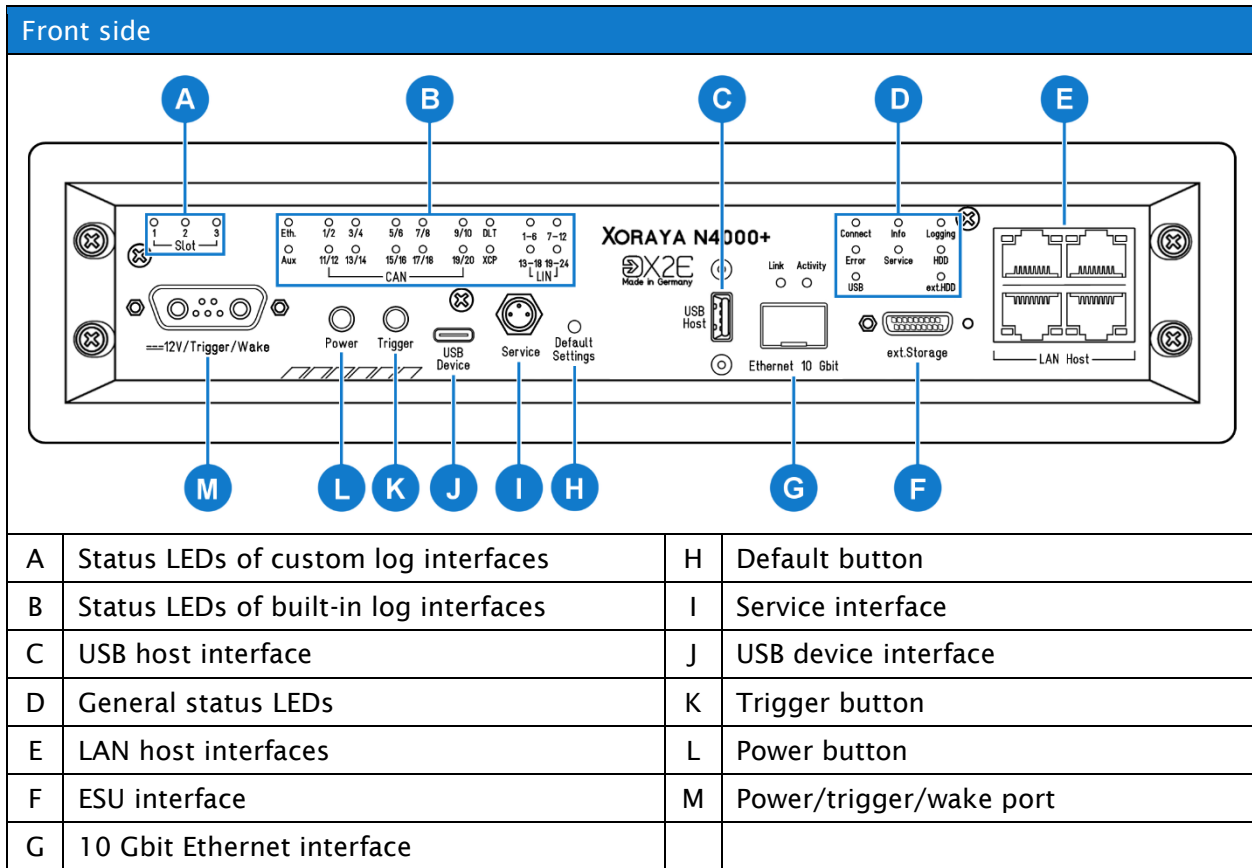

Status LEDs of custom log interfaces (A):

A constantly lit status LED indicates an existing and activated log interface on the corresponding slot. The LED flashes when messages are received.

Status LEDs of built-in log interfaces (B):

A constantly lit status LED indicates an existing and activated log interface or in case of CAN that at least one of both assigned channels is activated. The LED flashes when messages are received.

USB host interface (C):

By using a USB flash drive, the following functions are available:

- Data recording
 - Label the USB flash drive *XORAYALOG* and create the folder *usb_queue* there.
 - Check *Record on USB stick* in the *Hard Disk* category of the system settings. (→ Hard Disk)
 - Start data recording in HDD mode. (→ HDD mode)
- Updating the firmware
 - Create the folder *xoraya_update* on the USB flash drive and copy the firmware archive there.
 - Connect the drive and the firmware is automatically updated.
- Generating the supportfile
 - The supportfile is a set of files that you can send to X2E support to help solve technical issues.
 - Create the folder *xoraya_supportfile* on the USB flash drive.
 - Connect the drive and the supportfile is automatically generated. The *Info* LED flashes during the process.

Additionally, use the trigger input (**M**) or the trigger button (**K**) to safely disconnect the USB flash drive after use. Check the corresponding action of the Button interface. (→ Button)

General status LEDs (D):

These LEDs indicate the operating status of the N4000+.

LED	Meaning
Connect	Connection between N4000+ and XORAYASuite is established
Info	N4000+ is DHCP server
Logging	Logging in progress LED flashes as the logging stops, because the stopping process may take longer depending on the queue fill level
Error	Flashes when restarting after the power supply was interrupted and the N4000+ could not shut down safely In addition, the <i>HDD</i> LED flashes while the file system is being repaired
Service	Lights up constantly when the N4000+ is in firmware update or recovery mode Displays different error codes by flashing
HDD	Flashes when accessing the internal storage medium
USB	Flashes when accessing a connected USB flash drive
ext.HDD	Lights up when XORAYA ESU is connected <ul style="list-style-type: none"> ▪ Red (constantly): connection enabled (locked) ▪ Red (flashing): accessing the XORAYA ESU ▪ Green: connection disabled via button (unlocked)

LAN host interfaces (E):



The N4000+ features four ports to connect to a switch or directly to a PC. This is necessary to control the N4000+ via software and exchange data.

ESU interface (F):

This port is used to connect the additional device XORAYA External Storage Unit (ESU). If the N4000+ detects this device, the measurements in HDD mode are saved there instead of to the internal storage medium.

(➔ HDD mode)

The LEDs in the following table are both on the front and on the back side of the XORAYA ESU.

LED	Meaning
	Lights up when cable connection to N4000+ is established <ul style="list-style-type: none"> Red: connection enabled (locked) Green: connection disabled (unlocked)
	Lights up green when XORAYA ESU is voltage-supplied from the N4000+
	Flashes red when accessing the XORAYA ESU



Remove XORAYA ESU safely

To avoid data loss, always press this button for at least one second before disconnecting the cable connection. When the corresponding LED is lit green, you can pull the cable.

10 Gbit Ethernet interface (G)

This interface can be used for data recording or as a faster alternative to the 1 Gbit host interfaces (E). A plugged-in SFP+ module is required. X2E recommends the module FTLX8573D3BTL from Finisar.

Default button (H):

Press the default button with a pointed object for at least 3 seconds to reset all N4000+ settings to factory defaults.

Service interface (I):

In case of errors, this interface is used as a debugging interface by the X2E support team.

USB device interface (J):

This port has currently no function for the user.

Trigger button (K):

The function of this button depends on the N4000+ state. The following table describes these functions as delivered. Users can configure this behaviour via the XORAYASuite in the settings of the button interface. (→ Button)

State of the N4000+	Function
Sleep mode	N4000+ wakes up
Switched on	Start HDD recording
Switched on, recording active	<ul style="list-style-type: none"> ▪ Short press: Setting a mark (an event) in the recording ▪ Long press (3 seconds at least): Stop current recording

Power button (L):

If you press this button while the N4000+ is operational, the device switches to sleep mode.

If the N4000+ is operational and this button is pressed together with the trigger/wake button (**B**), the N4000+ turns off completely.

You cannot turn off the N4000+ using this button when the device is connected to a PC and the *Connect* LED is lit.

In this case, you can turn off the N4000+ via the *Logger* menu of the XORAYASuite. Here, you may choose between two options, i.e. *Shutdown* and *Shutdown (no wake up)*. (→ *Logger*)

Power/trigger/wake port (M):

By default, the N4000+ must be supplied with 12 V DC voltage. Optionally, it can also operate with power supplies in a certain specified range. Appendix

Trigger input and trigger button offer an analogous operation. A +12 V signal level at the trigger input is equivalent to pressing the trigger button. (→ *Trigger button*)

The wake input allows waking up the N4000+ from sleep. To that end, the wake signal must shift from 0 V to +12 V.

Back side

Configuration 1

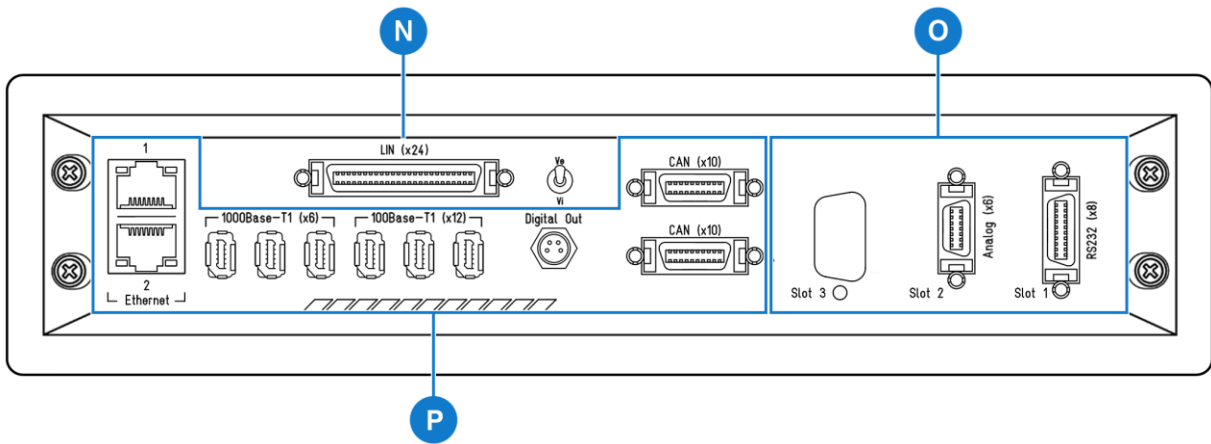

Configuration 2

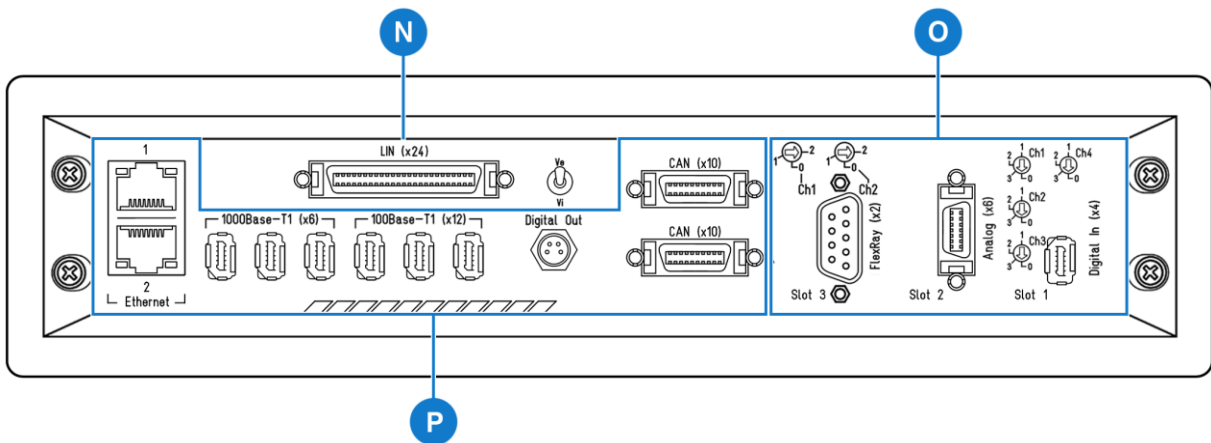

N	24x LIN add-on	P	Built-in interfaces
O	Custom interfaces		

24x LIN add-on (N):

This card adds 24 LIN channels to the available log interfaces of the N4000+.

The switch allows changing between internal and external power supply.

Use the internal power supply of the LIN measurement card only if the connected LIN device uses the N4000+ voltage as a reference voltage. Bear in mind that this is not possible when using the N4000+ in a 24-V electrical system, for example. In this case, connect the external power supply port to the corresponding reference voltage.

Custom interfaces (O):

The slots can be variably equipped with up to three additional interfaces.

Slot and channel number of each hardware interface are also displayed in multiple locations of the XORAYASuite tool *Configuration*:

(→ Interface configuration)

- Main overview for all interfaces
- Main overview for all channels of one interface type
- Settings for the corresponding interface channel

You find the rotary switch assignments in the chapter *Comissioning*.

(→ Configuring switches)

Built-in interfaces (P):

The built-in interfaces of each N4000+ are:

- 2x Gigabit Ethernet
- 6x 100/1000Base-T1
- 12x 100Base-T1
- 20x CAN
- 2x Digital Out

4 Commissioning

4.1 Unpacking

Upon unpacking, check whether the delivery is complete and all components appear in perfect condition. (→ Scope of delivery)

- ▶ Please contact X2E GmbH immediately should the delivery be incomplete or upon damaged components.
- ▶ Do not put any defective component into operation.

X2E GmbH can only accept your complaint and replace the affected component upon prompt notification.



Keep original packaging

Keep the original packaging and packing materials for later storage or further transport.

4.2 Selecting an installation location

The N4000+ installation location must meet the following criteria:

- Location of the DC power supply (12 V by default)
- Distance of at least 4 cm to other devices
- Solid and stable base
- Adequate airflow
- N4000+ front, back and top sides must not be covered

4.3 Installing the N4000+

X2E GmbH provides no special requirements for N4000+ installation. Install the N4000+ in the vehicle so as to avoid a damage risk at any time.

4.4 Installing the XORAYASuite

Zur Konfiguration Ihres N4000+ und zum Auslesen der aufgezeichneten Messwerte installieren Sie die grafische Benutzeroberfläche XORAYASuite auf einem PC mit den folgenden Mindestanforderungen.

Unterstützte Betriebssysteme:

- Microsoft® Windows® 7 (32 Bit oder 64 Bit)
- Microsoft® Windows® 8 (32 Bit oder 64 Bit)
- Microsoft® Windows® 10 (32 Bit oder 64 Bit)

Hardwareanforderungen:

- Prozessorgeschwindigkeit mindestens 1GHz
- Arbeitsspeicher mindestens 2 GB
- Speicherplatz ca. 120 MB verfügbar

Softwareanforderungen:

- Microsoft® .NET Framework Version 4.5 oder höher

Installation:

- ▶ Close all open programs.
 - ▶ Use the XORAYASuite setup wizard from the supplied data medium.
- or*
- ▶ Download the latest version of the XORAYASuite from the X2E-Wiki.
(→ X2E-Wiki)
 - ▶ Start the setup wizard and follow the instructions.

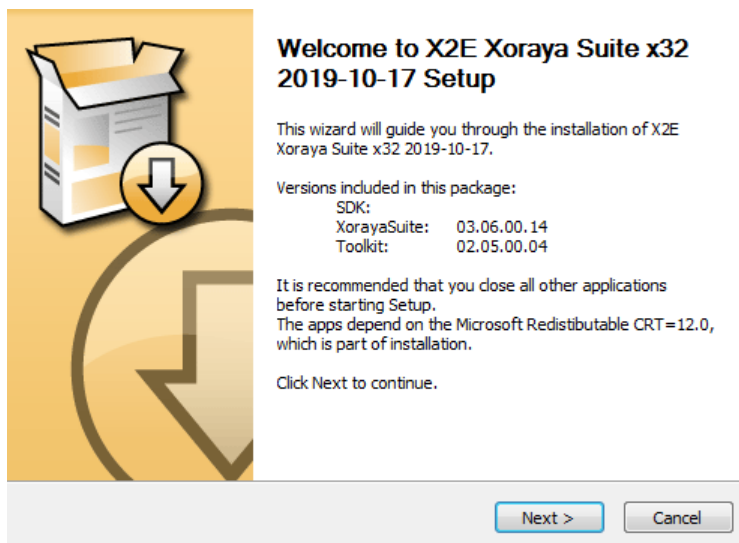

4.5 Connecting the N4000+ to the measuring environment

This section describes how to connect the N4000+ to the measuring environment.



CAUTION

Device damage due to incorrect connection sequence

The incorrect connection sequence can lead to abnormal behaviour or destruction of the N4000+.

- ▶ According to the numbering of the subsections, connect the interfaces first and then the power supply.
- ▶ Please note the correct connection sequence from top to bottom within the subsection.

4.5.1 Interfaces



Observe pin assignments

Please note the port pin assignments when connecting the N4000+ with the measuring environment. Wrong pin assignments lead to measurement errors.

Please note the following sequence:

- ▶ Connect the data cables of all data buses to be monitored in the measuring environment.
- ▶ Connect the data cables to the appropriate N4000+ ports.
- ▶ Wherever possible, tighten the connector screws on the N4000+ and in the measuring environment.

The N4000+ is connected to all data buses to be monitored.



Loss of data due to port disconnections

To avoid data loss, never disconnect the N4000+ during the current recording from connected data buses.

Furthermore, make sure that all connectors are firmly attached and the screws are tightened.

4.5.2 Power supply

This chapter describes the default connection to a DC power supply via the supplied power cable. If you use the optionally available power cable with AC adapter, please note the specifications on the adapter label.



DANGER

Electric shock due to improper connection of the power supply

Introducing the 4-mm plugs of the supplied power cable into low-voltage sockets can be fatal.

- ▶ Never introduce the 4-mm plugs into low-voltage sockets.
- ▶ Connect the supplied power cable only to a power source that meets the prescribed technical conditions.



CAUTION

Damage due to incorrect power supply

Using an incorrect power supply can lead to abnormal behaviour or destruction of the N4000+.

- ▶ Use only the supplied power cable.
- ▶ Please ensure correct polarity upon connection.
- ▶ Make sure that the power supply used meets the prescribed technical conditions.
- ▶ Make sure that the power supply lies within permissible operating voltage of the N4000+.
- ▶ Please note the allowable voltage level when feeding external signals.
- ▶ Please note the technical specifications on the label when using the optionally available power cable with AC adapter.



CAUTION

Damage due to faulty connection

When connecting with live contacts, transient fault currents with entrained mass may arise on interface connections which have been already connected.

- ▶ Please ensure contacts are de-energised when connecting the N4000+ to the power supply.



Continuous current of the DC power supply

A 12 V DC power supply must deliver a continuous current of 7.0 A. Use a regulated power supply or a car battery and note the required voltage and current levels.

Please note the following sequence:

- ▶ Connect the power cable to port **(L)** on the N4000+. (→ Connections and controls)
- ▶ Tighten the connector screws.
- ▶ Connect the black plug of the cable to 0 V or ground.
- ▶ Connect the red plug to the power supply.

The N4000+ is securely connected to the measuring environment.

Once the supply voltage is established, the N4000+ turns on and displays its operational status via the power button LED **(L)**.



CAUTION

Damage due to improper device shutdown

Disconnecting the power supply during operation may cause data loss and the destruction of the N4000+.

- ▶ Never disconnect the N4000+ from the power supply while in operation.
- ▶ Ensure proper connector seating and tighten the screws if possible.
- ▶ Only shut down the N4000+ through the XORAYASuite or the power button on the front panel.
- ▶ Pull the black plug connected to ground last when disconnecting the N4000+ from the power supply.

Der N4000+ ist mit einem intelligenten Energiemanagement ausgestattet, das für ein Absenken der Stromaufnahme auf max. 1 mA (bei 12 V Versorgungsspannung) im Ruhezustand sorgt.

The device goes into sleep mode via the following actions or under the following conditions:

- Pressing and holding the power button (**L**) for at least 2 seconds. Current recording stops automatically.
- If no data reach the log interfaces and no connection to the XORAYASuite is established for 10 minutes, the N4000+ shuts down automatically. This behaviour is configured using the main setting *Automatically Switch Off*. (→ Main Settings)

Users can wake up the N4000+ from sleep mode as follows:

- Pressing the power button (**L**)
- Switching the power supply off and on
- Signal change from 0 V to +12 V at the trigger or wake input (**M**)
- Pressing the trigger/wake button (**K**)
- Activity on a wakeable log interface

4.6 Connecting the N4000+ to the PC

This section describes how to connect the N4000+ to the PC. To do so, you will need a standard network cable.

Proceed as follows to connect:

- ▶ Connect the network cable to a switch.
or
 - ▶ Connect the network cable directly to your PC.
 - ▶ Connect the network cable to one of the LAN host interfaces (**E**) or the 10 Gbit Ethernet interface (**G**). (→ Connections and controls)
- The N4000+ is fully connected.

4.7 Configuring switches

- ▶ Configure the built-in terminators via the rotary switches on the back of the N4000+. (→ Connections and controls)
- ▶ Configure the switching thresholds for the 4 Digital-In interface channels separately.
- ▶ For the LIN interface, select between internal or external power supply via the toggle switch.

4.7.1 2x FlexRay

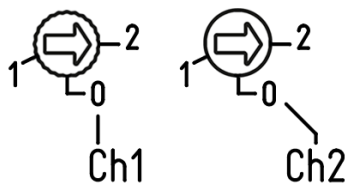

Position	Resistance
0	Open (∞)
1	2.6 k Ω
2	90 Ω

4.7.2 4x Digital-In

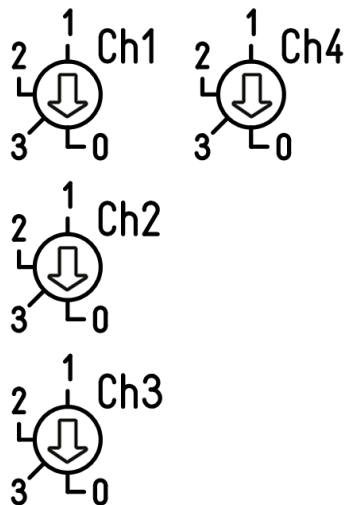

Position	Threshold
0	3.3 V
1	5 V
2	12 V
3	24 V

4.7.3 24x LIN



Position	Power supply
Vi	Internal
Ve	External

Use the internal power supply of the LIN measurement card only if the connected LIN device uses the N4000+ voltage as a reference voltage. Bear in mind that this is not possible when using the N4000+ in a 24-V electrical system, for example. In this case, connect the external power supply port to the corresponding reference voltage.

5 XORAYASuite

This chapter describes the operation of the graphical user interface XORAYASuite.

5.1 Starting

- ▶ Perform all commissioning steps. (→ Commissioning)
- ▶ Start the XORAYASuite by double-clicking the desktop icon.
- or*
- ▶ Start the XORAYASuite from the Windows Start menu.

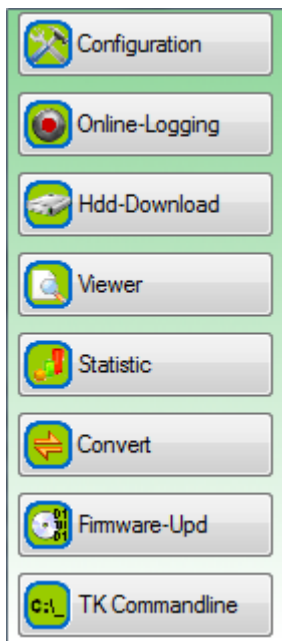

Upon start, XORAYASuite provides access to the various tools.

Tool	Function
Configuration	Customise the N4000+ behaviour
Online-Logging	Start and stop logging
Hdd-Download	Download measurements from the N4000+ storage medium
Viewer	Evaluate measurements
Statistic	Evaluate bus statistics
Convert	Convert log data to other formats
Firmware-Update	Update firmware
TK Commandline	Command line access to the XORAYAToolkit

- The XORAYASuite is started.



Windows notification area

Even after closing the launcher, the XORAYASuite continues to operate in the background. Click the icon in the Windows notification area to access tools or to close the XORAYASuite.

5.2 Menu bar

This section describes the five main menus of the menu bar.



Individual menu commands are not available in every tool.

5.2.1 File

Among other things, you can use the *File* menu to open and save files, or close the tool.

Command	Description
Open configuration	Opens a configuration file (XML)
Save configuration	Saves the current configuration
Save configuration as	Saves the current configuration under a different name
Save interface configuration as	Saves the current interface configuration under a different name The subitem <i>System settings and signals</i> saves everything except the interface configuration
Open	Opens an info file (DLI) and the associated log data Alternatively: ZIP archive containing info file and log data
Close	Closes the open log data
Open SWU/XSWU file	Opens a firmware image
Refresh properties	Reloads the current configuration of a selected interface from the N4000+
Recent files	Displays the most recently opened info files (DLI) and opens them when needed
Export preferences	Exports the output format settings in a preference file (XML)
Import preferences	Imports the output format settings from a preference file (XML)
Exit	Closes the tool

5.2.2 Logger

Among other things, you can use the *Logger* menu to connect or disconnect the N4000+ with the XORAYASuite.

Command	Description
Connect	Connects the selected N4000+
Disconnect	Disconnects the active connection to the N4000+
Offline-Logging > Start	Starts the logging process on the N4000+ storage medium
Offline-Logging > Stop	Stops the logging process on the N4000+ storage medium
Online-Logging > Start	Starts the logging process on the PC
Online-Logging > Stop	Stops the logging process on the PC
Probe-Logging > Start	Starts probe logging (further information in the quick manual XORAYA μ T-Z7/Probe)
Probe-Logging > Stop	Stops probe logging
Save changed configuration permanently	Stores the changed settings permanently on the N4000+
Customer default configuration > Create	Stores the current permanent configuration (profile <i>active</i>) in the <i>customer-default</i> profile
Customer default configuration > Load	Loads the <i>customer-default</i> configuration profile into the <i>active</i> profile
Reset configuration to factory settings > Interfaces	Resets the N4000+ interface configuration to factory defaults
Reset configuration to factory settings > System	Resets the N4000+ system configuration to factory defaults
Format HDD	Formats the N4000+ storage medium
Synchronize time with > Local	Sets the system time of the N4000+ to the current system time of the PC
Synchronize time with > Vehicle	Sets the system time of the N4000+ to the current system time of the connected vehicle
Restart	Restarts the N4000+
Restart and reconnect	Restarts the N4000+ and reconnects
Shutdown	Puts the N4000+ in sleep mode
Shutdown (no wake up)	Shuts down the N4000+ completely

This menu does not appear in the *Viewer* and *Convert* tools.

5.2.3 View

Among other things, you can use the *View* menu to switch between normal and detail view.

Command/Setting	Description
Normal	Normal view
Detail	Detail view that displays all categories and properties in the <i>Configuration</i> and <i>Online-Logging</i> tools
Tab selection	Determines which tabs are shown in the <i>Online-Logging</i> tool
Tile windows vertically/horizontally	Determines whether the elements <i>Export settings</i> and <i>Output formats selection</i> in the <i>Hdd-Download</i> tool are displayed next to or below the list of sessions or measurements
Autosize columns	Adjusts the width of the columns in the <i>Hdd-Download</i> tool to ensure all are visible simultaneously.
1 Comment ... 22 Type spread	Determines which tabs are shown in the <i>Hdd-Download</i> tool
Legend	Determines whether the legend is shown in the <i>Hdd-Download</i> tool

This menu does not appear in the tools *Viewer*, *Convert* and *Firmware-Update*.

5.2.4 Help

Among other things, you can use the *Help* menu to access this manual.

Command	Description
Logger manual	Opens the N4000+ user manual
About	Displays system information on the software and, if connected, on the N4000+
Update software	Opens the X2E-Wiki to download the current XORAYASuite version
Show logfile	Displays a log file for the tool
Supportfile	Generates a set of files that you can send to X2E support to help solve technical issues

5.2.5 Language

Use the *Language* menu to change the language of the XORAYASuite.

Setting	Description
German (Deutsch)	Changes the language of the XORAYASuite to German
English (Englisch)	Changes the language of the XORAYASuite to English



Other menus

The *Edit*, *Download*, *Convert* and *Settings* menus are only available in two tools at the most. Their descriptions can be found in the corresponding sections of this user manual.

5.3 Status bar

The status bar on the bottom of the window provides information about the connected N4000+, for example the storage medium usage. In addition, the user interface is also adjustable for smaller displays there. The following buttons do not appear in the tools *Viewer*, *Statistics* and *Convert*.



1	Show/hide menu bar	3	Show control dialogue
2	Show/hide toolbar	4	Show message queue

The control dialogue (3) allows quick access to the most important commands of the menu or tool bar.

5.4 Connecting and disconnecting the N4000+

The N4000+ is connected and disconnected in the same way regardless of the XORAYASuite tool. This section shows the process for the *Configuration* tool as an example.



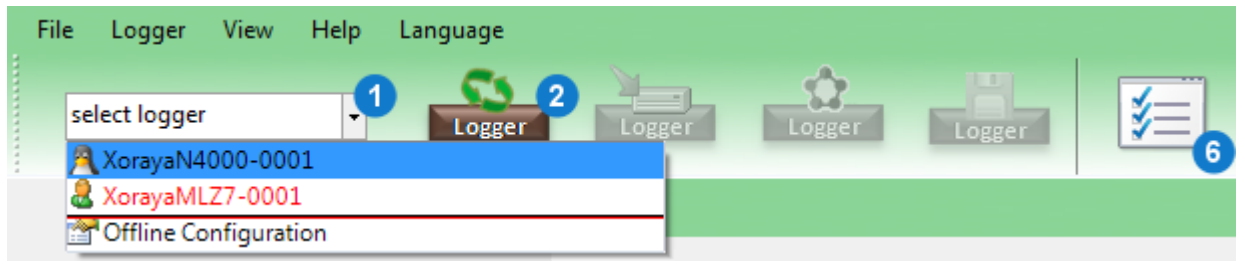



5.4.1 Connecting the N4000+



1	Display available loggers	6	Display settings
2	Establish connection to logger		

- ▶ Connect the N4000+ to the PC. (→ Connecting the N4000+ to the PC)
- ▶ Turn on the N4000+.
- ▶ Start the desired XORAYASuite tool. (→ Starting)
- ▶ Click *Display available loggers* (1) to start scanning for dataloggers.
- ▶ Select the desired N4000+ (alternative name: MLZU) using the assigned name.
- ▶ Click *Establish connection to logger* (2).
- or*
- ▶ In the *Logger* menu, click *Connect*. (→ Logger)
- The N4000+ is connected to the XORAYASuite.

Icons and text colours indicate the status of the N4000+:

-  and name **red** Network error, the N4000+ is located on a different subnet
-  and name **black** Disconnected N4000+
-  and name **red** Another user is connected to the N4000+
-  and name **blue** You are connected to the N4000+
-  Measurements are currently transferred from the N4000+ storage medium to the PC
-  N4000+ is in favourites list (→ Favourites)



Edit the configuration file

You can edit a configuration file (XML) previously created without connecting to the N4000+. To do so, select *Offline Configuration* in the drop-down list *Display available Loggers (1)* in the *Configuration* tool.

5.4.2 Disconnecting the N4000+

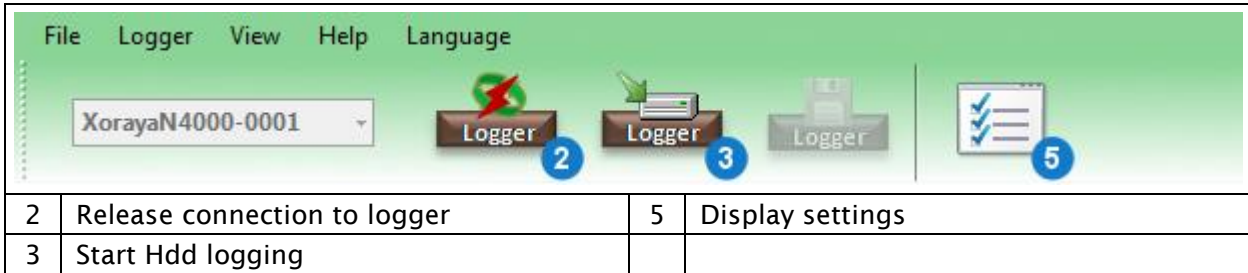

2	Release connection to logger	5	Display settings
3	Start Hdd logging		

- ▶ Click *Release connection to logger (2)*.
- or*
- ▶ In the *Logger* menu, click *Disconnect*. (→ *Logger*)
- N4000+ and XORAYASuite are disconnected.



HDD mode

Start the recording on the internal or external storage medium of the N4000+ via *Start Hdd logging (3)* or autonomously without a PC, as described in the relevant section. (→ *HDD mode*)

5.4.3 Favourites

You access the favourites list via *Display settings* button in the *Configuration*, *Online-Logging* or *Hdd-Download* tools.

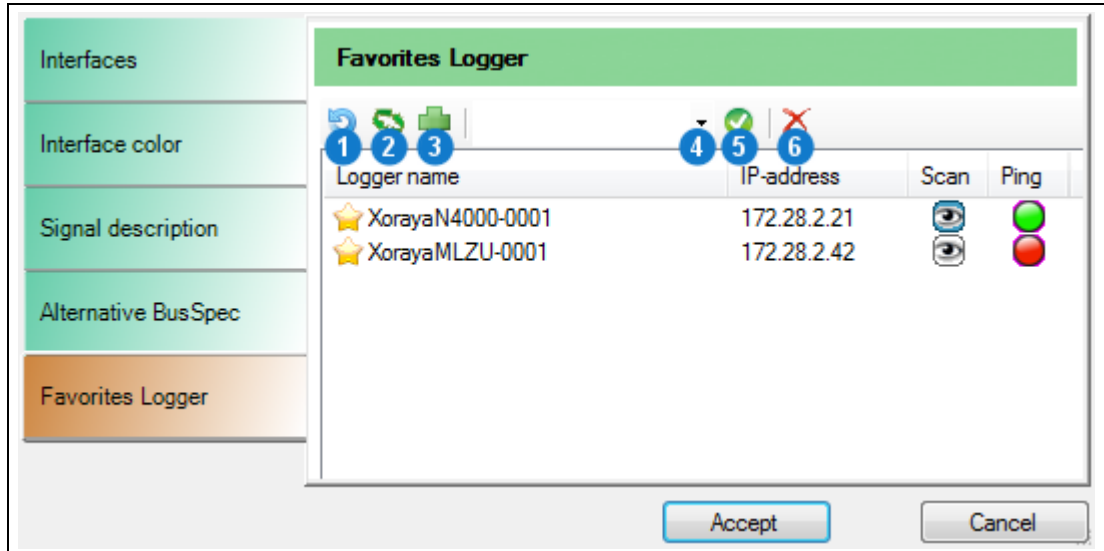

1	Refresh the device list	4	Devices in the network
2	Add currently connected device to favourites	5	Add selected device to favourites
3	Add a device to favourites manually	6	Remove device from favourite list

Save frequently used dataloggers in the favourites list. Favourites are displayed first in the list of available dataloggers and are marked with the star symbol.

Add N4000+ manually:

- ▶ Click *Add a device to favourites manually* (3).
- ▶ Specify *Logger name* and *IP-address*.
- ▶ Click *OK*.





Add N4000+ automatically:

- ▶ Click *Devices in the network* (4) to start scanning for dataloggers.
- ▶ Select the desired N4000+.
- ▶ Click *Add selected device to favourites* (5).

Additionally, you can add the currently connected N4000+ directly via button (2).

The symbols in the columns *Scan* and *Ping* display the current reachability of the dataloggers in the list. *Ping* reaches beyond subnet boundaries.

Meaning of the symbols:

-  and  reachable
 and  not reachable

5.5 Configuration

This tool allows the configuration of the N4000+ and its interfaces.

- ▶ Connect the N4000+ to the PC. (→ Connecting the N4000+ to the PC)
 - ▶ Turn on the N4000+.
 - ▶ Start the *Configuration* tool of the XORAYASuite. (→ Starting)
 - ▶ Connect to the desired N4000+. (→ Connecting the N4000+)
- The configuration can be performed.



WARNING

Defects influencing the environment

The incorrect N4000+ configuration can lead to the temporary, delayed or permanent functional failure of connected vehicles.

Connected vehicles being operated on public roads bear an increased risk of injury and damage.

- ▶ If available, use configuration templates provided by the vehicle manufacturer.
- ▶ Use preferably the passive recording modes of the interfaces.

All settings in the *Configuration* tool are stored permanently in the N4000+. Therefore, you can configure each N4000+ differently to meet the requirements of various application areas.

2	Release connection to logger	5	Display settings
3	Start Hdd logging	6	Save configuration file
4	Save changed configuration permanently	7	Categories

The tree structure on the left side of the window displays system settings, available interfaces and signals at the highest level. Expand the tree at the desired position and to the desired depth to access the sub-items.

The current configuration of the selected sub-item is displayed on the right side of the window. This is where you can perform any changes required and optionally save them as a configuration file (XML) on your PC via button (6). The toolbar (7) allows a quick jump to all categories of this level.

Use the *Default* tab to access the screen for the main default settings.

Use the *Properties* tab to access properties and thereby all available settings. This tab is only visible if the detail view is enabled.



Enabling the detail view

In the *View* menu, click *Detail* to enable the detail view.

You can view the properties sorted either alphabetically or by category. Properties that cannot be modified by the user are greyed out.

Configuration changes can be saved temporarily or permanently.

Save temporarily:

- ▶ Change the desired default setting or property.
 - The configuration is saved temporarily.

Changes to default settings or properties are discarded after the N4000+ restarts.

Save permanently:

- ▶ Click *Save changed configuration permanently (4)*.
or
- ▶ In the *Logger* menu, click *Save changed configuration permanently*.
 - The configuration is saved permanently.

**Delayed change update**

For certain settings, such as *Name* and *IP Address*, changes are not applied immediately but only after a N4000+ restart.

The *Maintenance* symbol indicates whether there is a N4000+ malfunction and, where appropriate, the error source.

**HDD mode**

Start the recording on the internal or external storage medium of the N4000+ via *Start Hdd logging (3)* or autonomously without a PC, as described in the relevant section. (→ HDD mode)

Use *Display settings (5)* to customise the following:

- Colour assignments for the interfaces
- Load signal description file (→ Signal description settings)
- Load configuration template (Busspec)
- Manage logger favourites (→ Favourites)

5.5.1 System configuration

System settings are configured via properties stored on the N4000+.

These properties fall under various categories:

- Main Settings
- Network
- Hard Disk
- Snapshot
- Versions
- Profile

Select the category:

- ▶ Click the root element of *System Settings* to display the main settings of all categories.

or

- ▶ Click a category to view the main settings of this category.

System Settings > Main Settings:

The screenshot shows the 'Main Settings' window with the following details:

- Title Bar:** Main Settings
- Tabs:** Default, Properties (selected)
- Name:** XorayaN4000-0001
- Comment:** (empty)
- System Time:** 18 Dezember 2019 - 10:29:30. Includes 'PC' and 'Vehicle' buttons.
- Power On Time:** 18 Dezember 2019 - 10:22:31
- Automatically Switch Off:** 10 min. Includes an 'Acoustic feedback' checkbox.
- Raw Vehicle Time:** Not available. Includes a 'Reload' button.
- Seen at on Interface:** Not available.

Setting	Description	Default
Name	Freely selectable name of the N4000+	XorayaN4000+<SerialNumber>
Comment	Current system time, internally with a precision of 100 ns Also used as a timestamp during logging	
System Time	Internally used property for the system time	
Automatically Switch Off	Time period after which the N4000+ shuts down, provided: <ul style="list-style-type: none"> ▪ there is no connection to the XORAYASuite ▪ there is no activity on any interface for which <i>Prevent Sleep Mode</i> is activated Values: Never, 1 min, 10 min, 20 min, 30 min, 60 min	10 min
Acoustic feedback	Acoustic feedback when: <ul style="list-style-type: none"> ▪ data recording is starting ▪ N4000+ is shutting down/sleeping 	Off



System Time

Click the appropriate button to synchronise with the PC or the vehicle time.

System Settings > Network:

The sub categories are assigned to the following interfaces
(→ Connections and controls):

- LAN Host eth0 LAN host interfaces (**E**)
- LAN Host eth1 10 Gbit Ethernet interface (**G**)

The screenshot shows the configuration for the LAN Host eth0 interface. It includes fields for dynamic and fixed IP addresses, gateway addresses, and netmasks. It also displays the current IP address (172.28.2.38), current MAC address (00:21:d5:02:00:06), current DHCP mode (1), and max transmit unit (mtu) set to 1500. A connection matrix is shown with columns for Source \ Target, bottom_left, top_left, bottom_right, top_right, and host. A blue box highlights the matrix, and a dropdown menu at the bottom is set to 'Static MAC to IP assignment when DHCP server is active'.

1	Overall view	4	Connection matrix
2	Separate view by ports	5	Open MAC-IP assignments
3	Symmetrical editing		

Setting	Description	Default
dynamic assigned IP-Address	Activate DHCP	On
<DHCP-Server>	N4000+ DHCP mode <i>On</i> : DHCP server <i>Off</i> : DHCP client	On
IP Address	IP address assigned to the N4000+ if: <ul style="list-style-type: none"> ▪ <DHCP-Server> = <i>On</i> or ▪ <i>fixed IP-Address</i> = <i>On</i> 	10.104.2.21
Gateway Address	Gateway address assigned to the N4000+ if: <ul style="list-style-type: none"> ▪ <DHCP-Server> = <i>On</i> or ▪ <i>fixed IP-Address</i> = <i>On</i> 	0.0.0.0
Netmask	Netmask that divides the IP address into network and host part	255.255.255.0
fixed IP-Address	N4000+ with static IP address	Off
max transmit unit (mtu)	maximum packet size on the network layer (in Bytes)	1500

Provided the check box is selected, the N4000+ is only DHCP server if it cannot find another DHCP server within the network. Otherwise, the N4000+ requests the IP address from this server, acting as DHCP client.

Edit connection matrix **(4)**:

- ▶ Activate or deactivate the connections between the front switch ports.
- ▶ Activate or deactivate the ports as hosts.

If the button *Symmetrical editing* **(3)** is enabled, changing a connection automatically changes the opposite direction.

Change between *Overall view* **(1)** and *Separate view by ports* **(2)** as desired.

Static MAC to IP assignment when DHCP server is active:

eth	MAC	IP
! eth0	00:11:22:33:44:55	172.28.1.64
! eth0	66:77:88:99:aa:bb	172.28.1.128

MAC		IP
00:00:00:00:00:00	<->	10 . 104 . 2 . 0
00:00:00:00:00:00	<->	10 . 104 . 2 . 0
00:00:00:00:00:00	<->	10 . 104 . 2 . 0
00:00:00:00:00:00	<->	10 . 104 . 2 . 0
00:00:00:00:00:00	<->	10 . 104 . 2 . 0

5	Close MAC-IP assignments	7	Refresh table of PCs in the network
6	Delete MAC-IP assignment		

DHCP server mode is intended for direct connections to PCs. You can bind MAC addresses of up to five PCs to IP addresses. Type them in manually or double-click in a row of the table that contains the addresses of the PCs in the network.

Red exclamation marks flag PCs outside the IP range.



Special care in network settings

Exercise extreme caution when changing these settings. Under certain circumstances, incorrect network settings of the N4000+ cannot be corrected.

In this case, you should reset the N4000+ back to factory defaults by pressing the default button (**H**) for 3 seconds. (→ Connections and controls)

System Settings > Hard Disk:

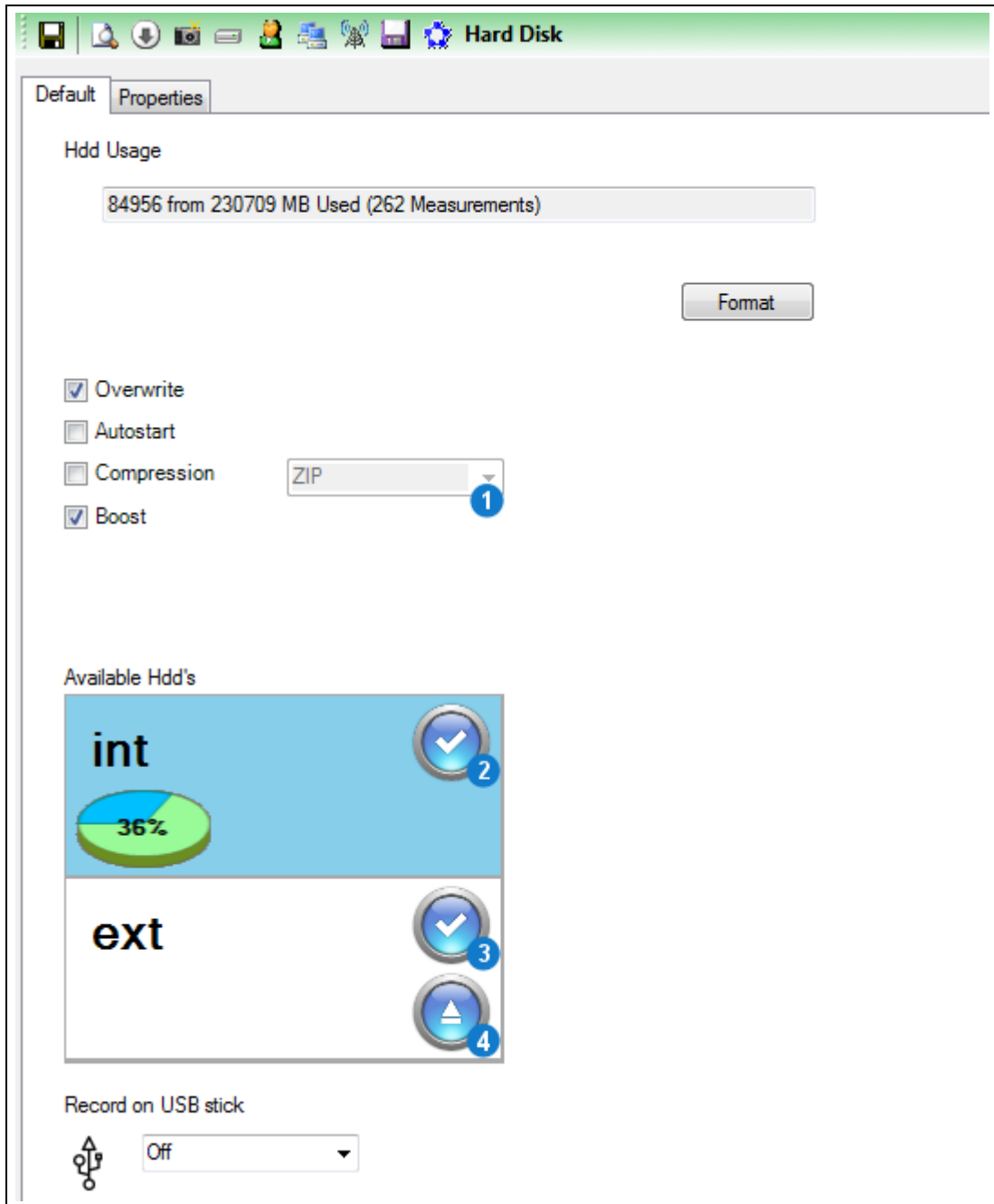

1	Compression method	3	Activate ESU*
2	Activate internal storage medium	4	Remove ESU safely*

* Only with connected XORAYA ESU

These settings and displays refer to the currently active storage medium, represented by the blue background colour.

If a XORAYA ESU is connected to interface (I), you change the active storage medium via the buttons (2) and (3). (→ Connections and controls)

Setting	Description	Default
Overwrite	Control the N4000+ behaviour if the storage medium is full <i>On</i> : Oldest session or measurement is overwritten <i>Off</i> : Recording is terminated	On
Autostart	Immediate recording after switching on the N4000+ or after disconnecting with the XORAYASuite	Off
Compression	Compress data before saving	Off
Boost	Increase write speed on the storage medium when processing the default-queue for packet data	On
Record on USB stick	HDD mode recording on a connected USB flash drive instead of on the internal or external storage medium <i>Off</i> : Disabled <i>Loop</i> : Circular buffer, which contains the most recent minutes of the recording <i>Linear</i> : Ongoing	Off



Compression

Compression reduces the data volume and, as a result, the download time, because data are decompressed on the PC.

After selecting the check box *Compression*, choose the compression method via the drop-down list (1):

- ZIP (slower, higher compression rate)
- LZ4 (faster, lower compression rate)

In addition to the settings, this view presents the usage of the storage medium and the number of stored measurements.

Use the *Format* button to delete all existing data from the storage medium.



Record on USB stick

For this mode, it is required that the connected USB flash drive is named *XORAYALOG* and contains the folder *usb_queue*.

System Settings > Snapshot:

Snapshots can be created during the measurement to track particularly interesting time periods. The moment you raise the corresponding trigger, all data received for a user-definable time before and after this moment, are Measurement data are processed as queues on the log interfaces. In addition to the default-queue for packet data, the N4000+ is able to use the faster stream-queue where Ethernet data are saved directly without creating statistics. You can set snapshots for both queues separately.

Setting the snapshot:

- ▶ Configure the snapshot of the desired queue.
- ▶ Create one or multiple triggers for the action *logger.snapshot*.
(→ Trigger)
or
- ▶ Activate the property *snapshot_on_log_press* of the button interface.
(→ Button)

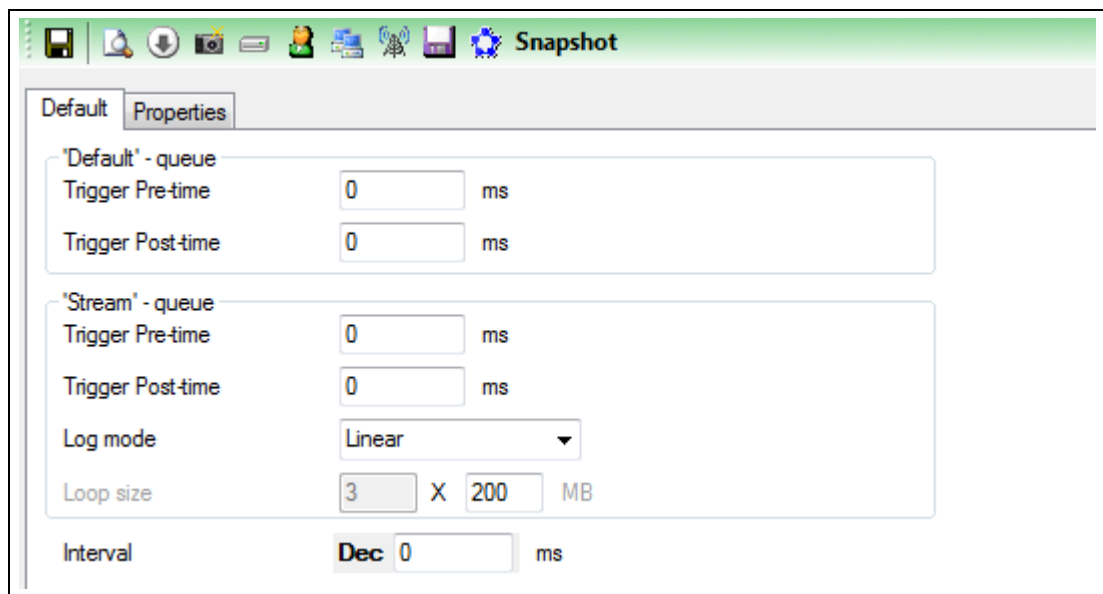

Setting	Description	Default
Trigger Pre-time (Default-queue)	Leading time of the snapshot for the default-queue (in ms)	0
Trigger Post-time (Default-queue)	Trailing time of the snapshot for the default-queue (in ms)	0
Trigger Pre-time (Stream-queue)*	Leading time of the snapshot for the stream-queue (in ms)	0
Trigger Post-time (Stream-queue)*	Trailing time of the snapshot for the stream-queue (in ms)	0
Log mode (Stream-queue)*	Snapshot recording mode for the stream-queue <i>Linear</i> : Ongoing <i>Loop</i> : In a loop that is overwritten as the specified size is reached	Linear
Loop size (Stream-queue)*	Factor determining the size of the loop (in MB, multiplied by a fixed predefined value)	3
Interval	Time range (in ms) during which multiple triggered snapshots are prevented Too many snapshots in very little time may lead to abnormal behaviour of the N4000+	0

System Settings > Profile:

You can save different N4000+ configurations using profiles. The following names are reserved for special profiles:

- active the permanently saved configuration, which is loaded when the N4000+ starts
- default the factory default configuration
- customer-default a customer default configuration

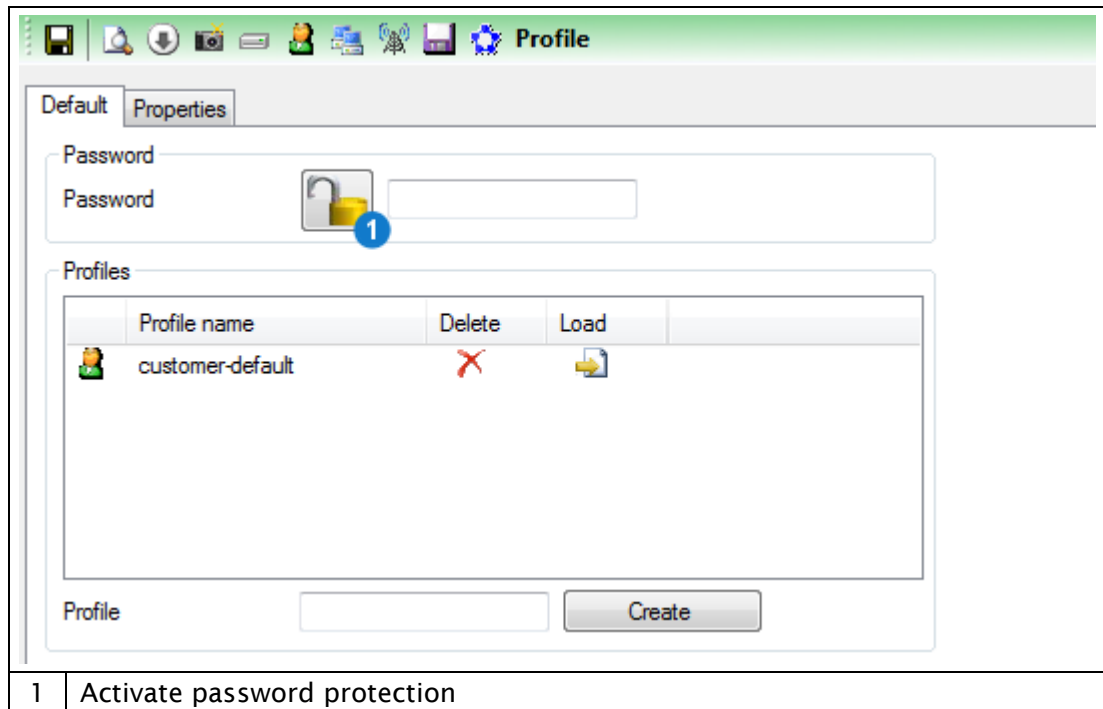

Create *customer-default* profile:

- ▶ Enter *customer-default* in the text box and click *Create*.
or
- ▶ In the *Logger* menu, click *Customer default configuration > Create*.

Load *customer-default* profile:

- ▶ Click *Load* in the row of the *customer-default* profile.
or
- ▶ In the *Logger* menu, click *Customer default configuration > Load*.
or
- ▶ Press the default button (**H**) for at least 1 second, but no more than 3 seconds. (➔ Connections and controls)

Load *default* profile:

- ▶ Press the default button for at least 3 seconds.

Protect *active* profile:

- ▶ Enter a *Password*.
- ▶ Click *Activate password protection (1)*.
- ▶ In the main toolbar, click *Save changed configuration permanently*.
- ▶ Disconnect and reconnect again to the N4000+.

The *active* profile is protected:



With enabled password protection, you can still temporarily save settings and create profiles, without needing to enter the password.

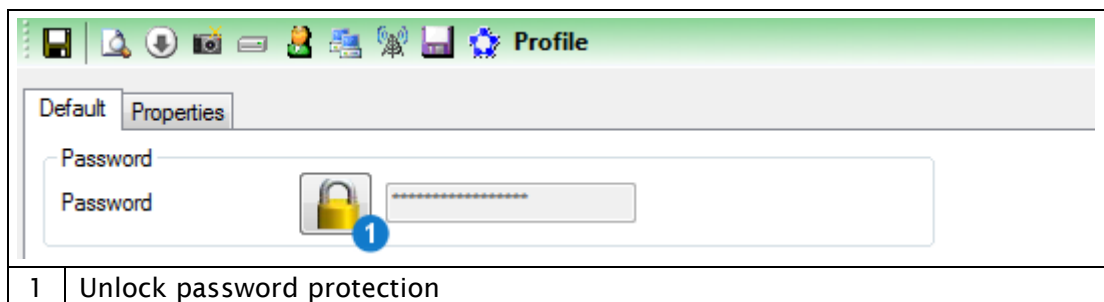

Unlock password protection for *active* profile:

- ▶ Click *Unlock password protection (1)*.
- ▶ In the newly opened window, enter the correct *Password*.
- ▶ Click *OK*.

The password protection is unlocked:



Reset password

If you have forgotten your password, you can reset the N4000+. (→ Resetting to factory defaults)

As you do so, the password as any other configuration changes will be reset.

System Settings > Export:

You can save the export settings and output formats for the *Hdd-Download* tool on the N4000+ itself. This way, the settings are centrally defined and do not depend on the PC used for downloading later.

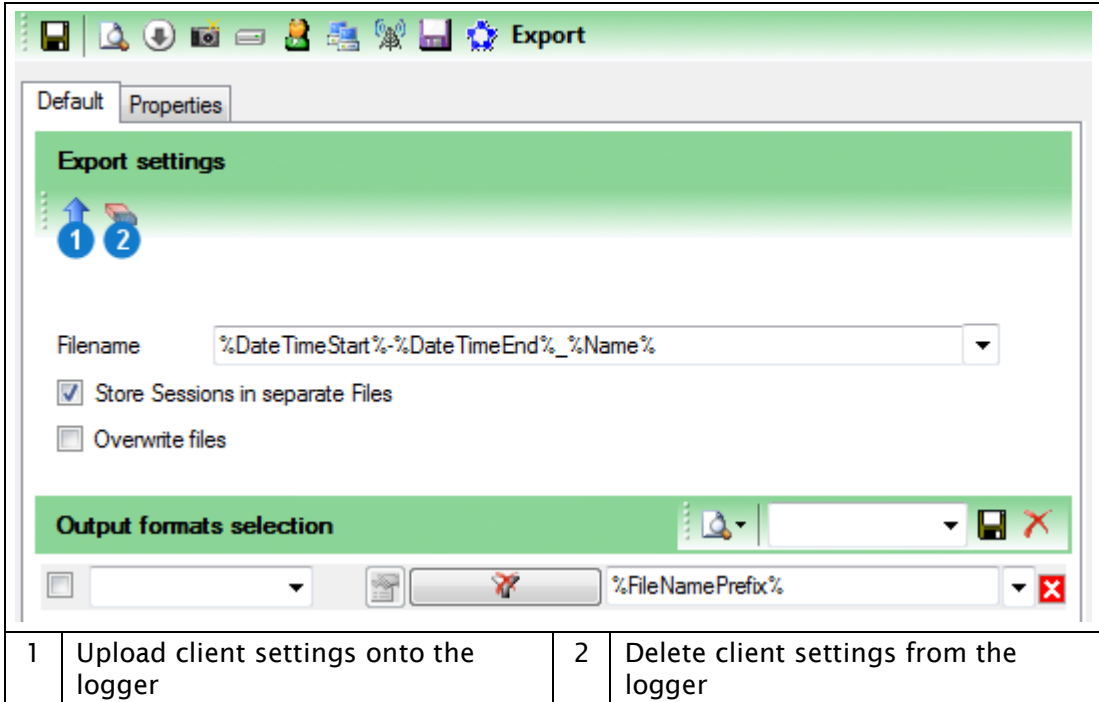

1	Upload client settings onto the logger	2	Delete client settings from the logger
---	--	---	--

Save settings on the N4000+:

- ▶ Specify the export settings. (→ Export settings)
- ▶ Specify the output formats. (→ Output formats selection)
- ▶ Click *Upload client settings onto the logger (1)*.
 - The settings are temporarily or permanently saved on the N4000+ and can be loaded in the *Hdd-Download* tool.

Reset settings:

- ▶ Click *Delete client settings from the logger (2)*.

System Settings > DLN:

Set up a *Distributed Logging Network*, consisting of data sink (master) and one or multiple probes. For further information, see the quick manual for the XORAYA μ T-Z7 probe.

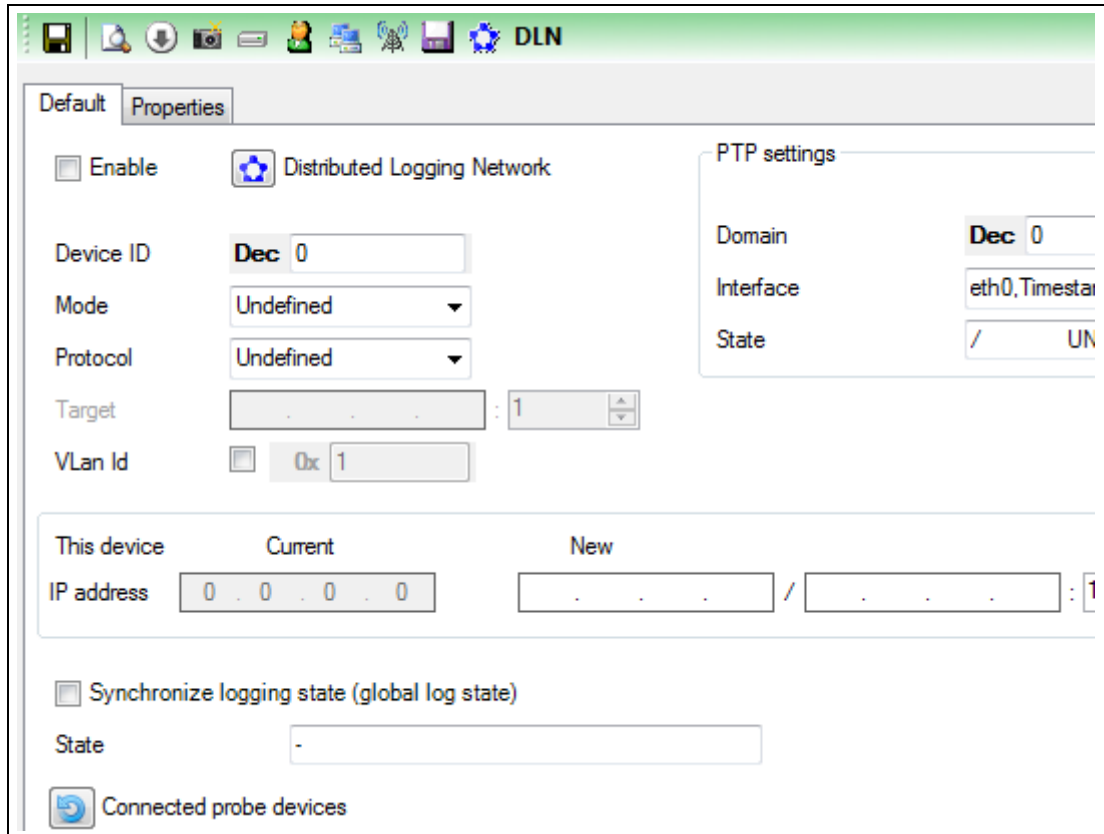

System Settings > Versions:

All properties in this category are immutable and purely informative. Among other things, this displays version numbers for various N4000+ components, as well as additionally activated licences.

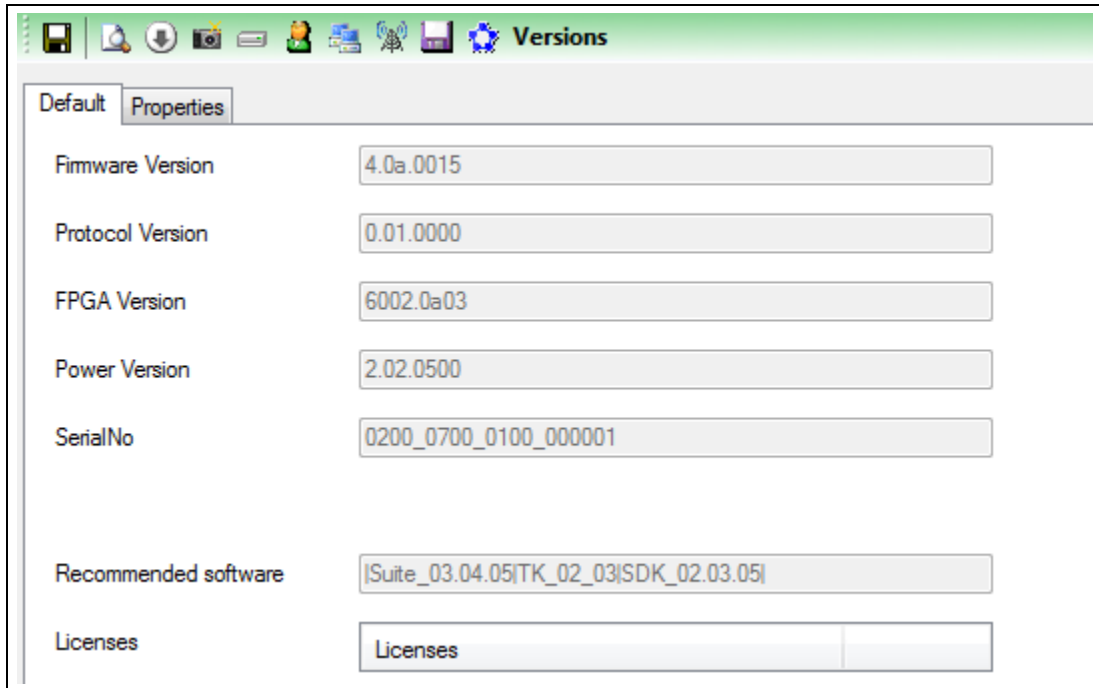

5.5.2 Interface configuration

Interface settings are configured via properties stored on the N4000+.

These properties fall under various categories:

- Settings
- Filter
- Trigger
- Routing
- Other
- Advanced

Interface or channel selection:

- ▶ Click the root element *Interfaces* to display the main settings of all interfaces.

or

- ▶ Click an interface to display the main settings for all channels of this interface.

or

- ▶ Click an interface channel to display the main settings for this channel.

Cross-references to the interfaces		
→ CAN	→ Ethernet	→ Event
→ FlexRay	→ VIDEO	→ Button
→ LIN	→ DiagCCP	
→ RS-232	→ DiagXCP	

Interfaces:

Interfaces										
Default Properties										
Enable	Wake	Prevent Sleep	Acknowledge / Send	Channel	Instance	Alias	Bus-Id	Rate of Transfer [kB]	High level interfaces	Slot
<input type="checkbox"/>	<input type="checkbox"/>	<input type="checkbox"/>	<input type="checkbox"/>							
<input checked="" type="checkbox"/>	<input checked="" type="checkbox"/>	<input checked="" type="checkbox"/>	<input type="checkbox"/>	Can	1	can1		500		
<input checked="" type="checkbox"/>	<input checked="" type="checkbox"/>	<input checked="" type="checkbox"/>	<input type="checkbox"/>	Can	2	can2		500		
<input checked="" type="checkbox"/>	<input checked="" type="checkbox"/>	<input checked="" type="checkbox"/>	<input type="checkbox"/>	Can	3	can3		500		
<input checked="" type="checkbox"/>	<input checked="" type="checkbox"/>	<input checked="" type="checkbox"/>	<input type="checkbox"/>	Can	4	can4		500		
<input checked="" type="checkbox"/>	<input checked="" type="checkbox"/>	<input checked="" type="checkbox"/>	<input type="checkbox"/>	Can	5	can5		500		
<input checked="" type="checkbox"/>	<input checked="" type="checkbox"/>	<input checked="" type="checkbox"/>	<input type="checkbox"/>	Can	6	can6		500		
<input checked="" type="checkbox"/>	<input checked="" type="checkbox"/>	<input checked="" type="checkbox"/>	<input type="checkbox"/>	Can	7	can7		500		
<input checked="" type="checkbox"/>	<input checked="" type="checkbox"/>	<input checked="" type="checkbox"/>	<input type="checkbox"/>	Can	8	can8		500		
<input checked="" type="checkbox"/>	<input checked="" type="checkbox"/>	<input checked="" type="checkbox"/>	<input type="checkbox"/>	Can	9	can9		500		

- ▶ Double-click a row in the table to jump directly to the corresponding interface or to the corresponding channel.



Reducing power consumption of the N4000+

To reduce the N4000+ power consumption, disable all channels unneeded.

CAN:

4 of the 20 CAN channels are always FD-capable. By default, the FD-specific settings are missing on the remaining channels.



CANFD_4PLUS_#

For each of these licences, the number of CAN-FD-capable channels is increased by 4.

Check in category *Versions* of system settings to verify which licences are activated for your XORAYA Z7.

(→ Versions)

CAN > Settings:

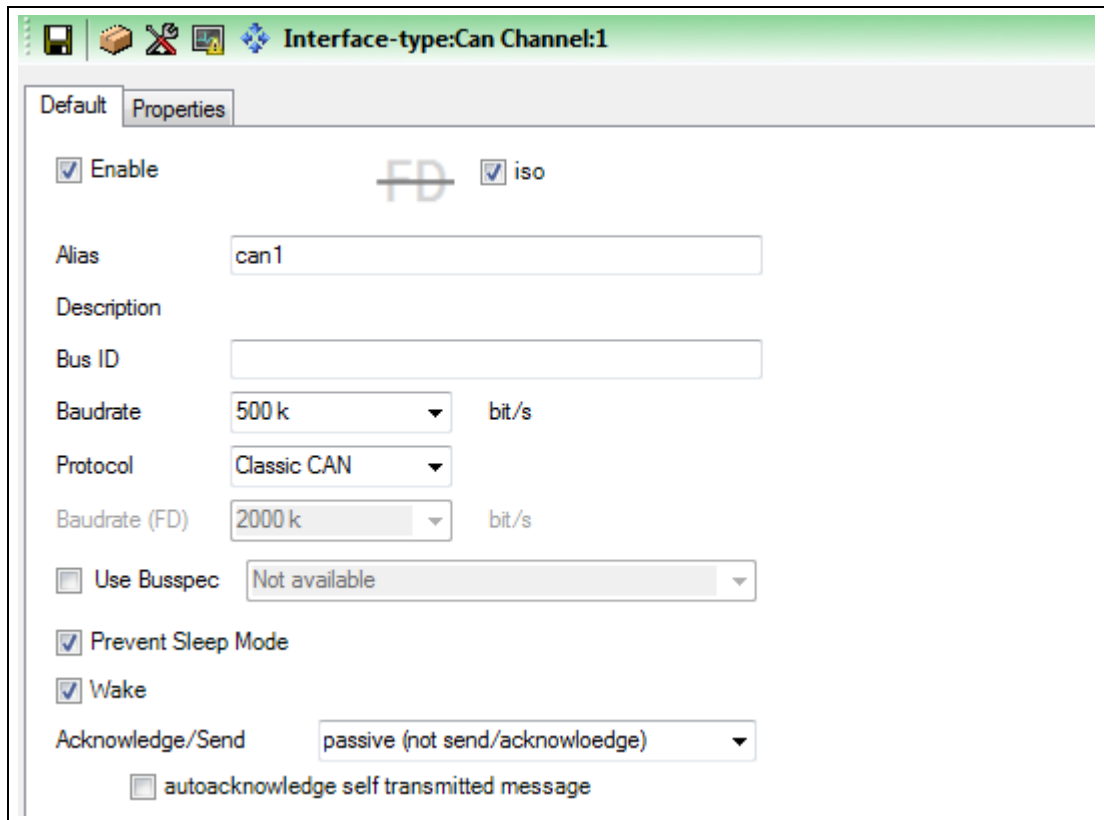

Setting	Description	Default
Enable	Turn on logging for this channel	On
iso	CAN FD standard <i>On:</i> ISO 11898-1 <i>Off:</i> original standard by Bosch	On
Alias	Freely selectable channel name	can#
Bus ID	Additional ID for subsequent evaluation	
Baudrate	Transfer rate (in bit/s) Values: 100 k, 125 k, 200 k, 250 k, 400 k, 500 k, 666 k, 800 k, 1000 k	500 k
Protocol	<i>Classic CAN</i> or <i>CAN-FD</i>	Classic CAN
Baudrate (FD)	Transfer rate for the payload section of a CAN FD message (in bit/s) Values: 500 k, 1000 k, 2000 k	2000 k
Use Busspec	Load configuration template provided by the vehicle manufacturer	Off
Prevent Sleep Mode	N4000+ will not go into sleep mode as long as there is activity on this channel	On
Wake	N4000+ wakes up from sleep mode as soon as there is activity on this channel	On
Acknowledge/Send	Acknowledgment and transmission capacity <i>Send and acknowledge:</i> N4000+ operates in active mode on the CAN bus (transmission possible, acknowledgment of CAN messages, generation of error frames) <i>passive (not send/acknowledge):</i> N4000+ operates in passive mode on the CAN bus (receipt possible, no acknowledgment of CAN messages, no generation of error frames) <i>Send but NOT acknowledge:</i> N4000+ operates in semi-passive mode on the CAN bus (transmission possible, no acknowledgment of CAN messages, no generation of error frames)	passive (not send/acknowledge)
autoacknowledge self transmitted message	Messages sent by the N4000+ are automatically acknowledged	Off

CAN > Trigger:

1	Number of bytes for the trigger	3	Number of bytes for the response
2	8-byte blocks of the trigger	4	Byte values of the response

The following check boxes affect the IDs of the specified CAN messages in this category:

- Extended frame Use 29-bit ID instead of 11-bit ID
- Can FD Activate CAN FD mode
- Bit Rate Switch Transfer payload with CAN FD baudrate
(Requirement: *Can FD* selected)

Configure triggers:

- ▶ Select the check box *Enable Trigger from following CAN message*.
- ▶ Under *Id*, specify the ID of the CAN message that raises a trigger. (→ Changing the numbering system)
- ▶ Select the check boxes *Extended Frame*, *Can FD* and *Bit Rate Switch* as desired.
- ▶ Specify the *Number of bytes for the trigger (1)*.
- ▶ Select one of the *8-byte blocks of the trigger (2)* for editing.
- ▶ Specify the bytes of this payload block. (→ Set bits)
- ▶ Specify further 8-byte blocks of this trigger.
- ▶ Repeat as necessary for up to a total of five triggers.

The following CAN messages are preconfigured as triggers:

ID	Byte 1	Byte 2 (X = "don't care")
1d6	C8	1X
1d6	C4	1X
1d6	F8	DX
1d6	F4	DX
7b7	00	XX

Configure trigger responses:

- ▶ Select the check box *Send as response following CAN message*.
- ▶ Specify the ID of the CAN message that is sent as response to a trigger.
- ▶ Select the check boxes *Extended Frame*, *Can FD* and *Bit Rate Switch* as desired.
- ▶ Specify the *Number of bytes for the response (3)*.
- ▶ Specify the *Byte values of the response (4)*.
- ▶ Repeat as necessary to configure a second trigger response.



CAN trigger responses

Trigger responses are only sent if the setting *Acknowledge/Send* is not set to *passive*.

To test the transmission of a CAN response, click the corresponding button.

CAN > Routing:

Here, you configure the routing of messages received on other CAN channels via the currently selected channel. The payload is not changed while the IDs of source and target message can differ.

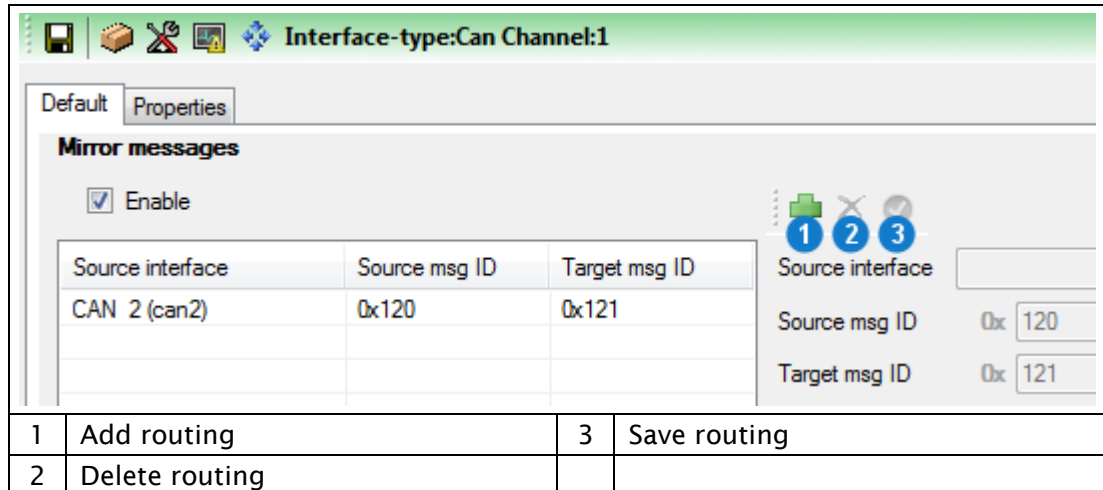

Configure routing:

- ▶ Select the check box *Enable*.
- ▶ Click *Add routing (1)*.
- ▶ Under *Source interface*, choose the receiving CAN channel.
- ▶ Under *Source msg ID*, specify the ID of the source message. (→ Changing the numbering system)
 - Select the check box *Ext. ID* for a 29-bit ID instead of a 11-bit ID.
- ▶ Optional: Under *Target msg ID*, specify content and length of the target message ID.
 - If you do not specify a target message ID, the source message ID is applied.
- ▶ Click *Save routing (3)*.
- ▶ Repeat as necessary for further routings via this channel.

Meaning of the symbols for the available CAN channels:

- ✓ enabled
- ✗ not enabled

CAN > Other:

Here, you specify if the N4000+ sends general system statistics and interface statistics as CAN messages during data recording. These CAN messages contain signals, which hold the specific values.

General system statistics are, for example:

- RAM queue fill level
- CPU load
- Storage medium usage

Interface statistics:

- Transfer speed in kB/s
- Messages per second
- Overflow counter
- Error counter

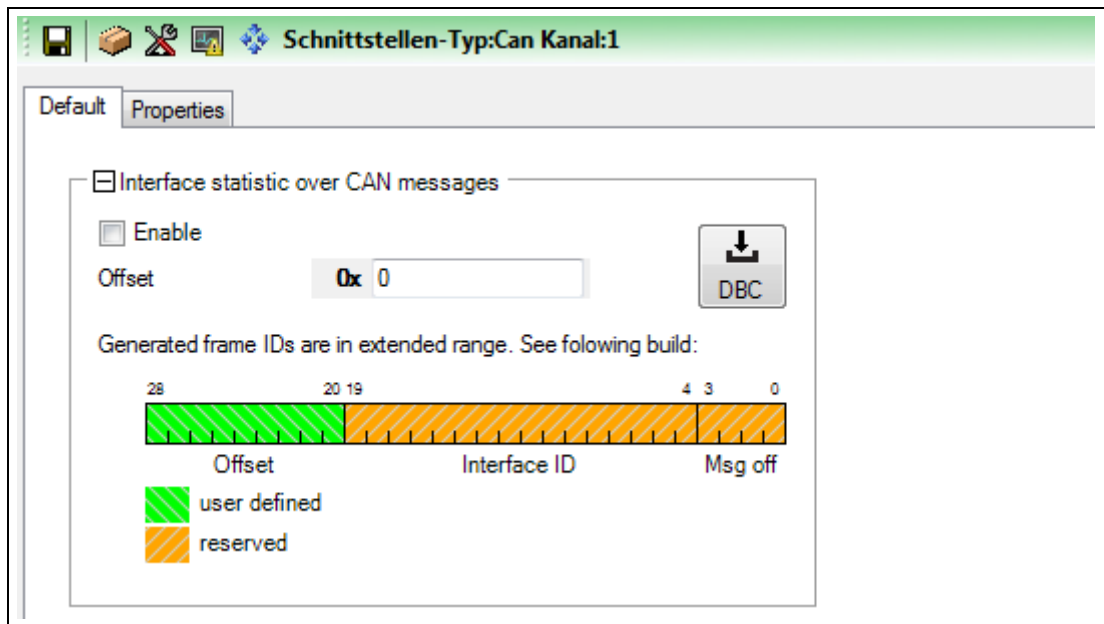

Setting	Description	Default
Enable	Enable interface statistic over CAN messages	Off
Offset	User-defined ID offset of the sent statistic messages	0

The user-defined *Offset* within the 29-bit ID is displayed in green. This offset applies to each generated ID. The rest of the ID in orange is reserved and is automatically adjusted for each interface channel by the software.

Click the *DBC* button to open the generated messages and signals as a DBC file in a text editor and to save them for later analysis.



Restriction of statistic over CAN

Statistic over CAN messages can only be activated on one CAN channel at the same time.

FlexRay:

FlexRay > Settings:

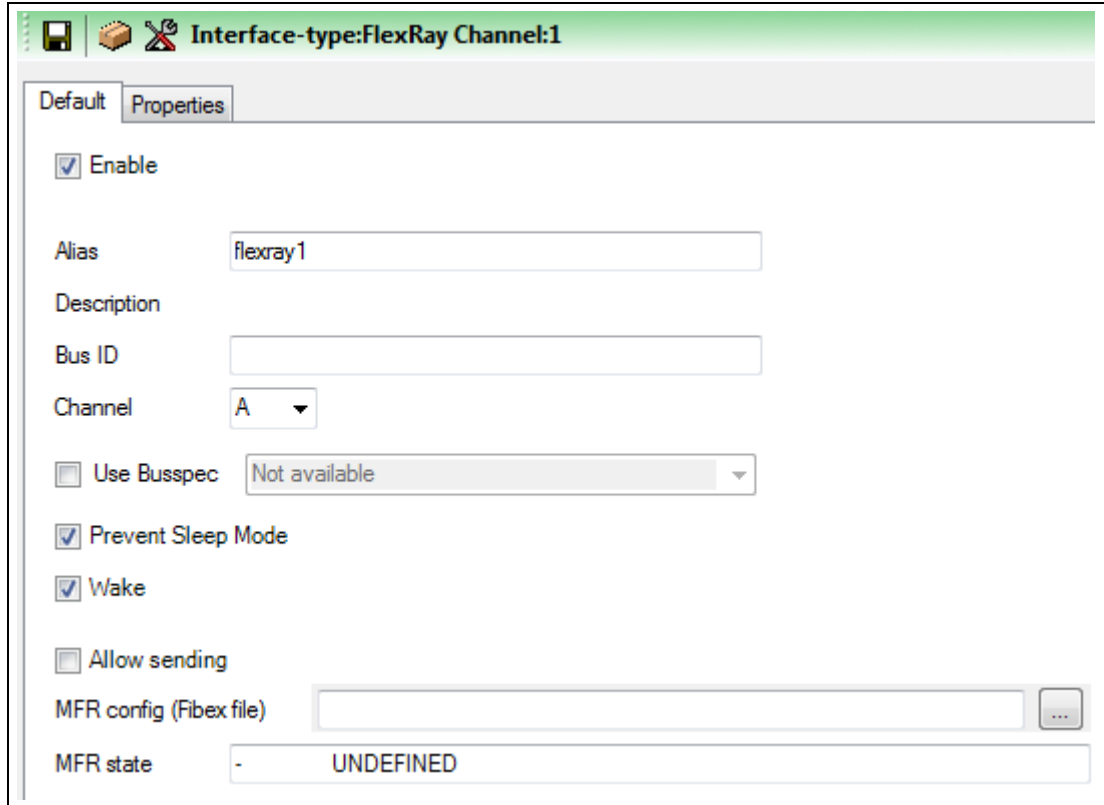

Setting	Description	Default
Enable	Turn on logging for this channel	On
Alias	Freely selectable channel name	flexray#
Bus ID	Additional ID for subsequent evaluation	
Channel	Selection, which one of both bus channels is used Values: A, B	A
Use Busspec	Load configuration template provided by the vehicle manufacturer	Off
Prevent Sleep Mode	N4000+ will not go into sleep mode as long as there is activity on this channel	On
Wake	N4000+ wakes up from sleep mode as soon as there is activity on this channel	On
Allow sending	Allow sending on this channel (requirement for XCP on FlexRay) Additionally, a FIBEX file is required	Off
MFR config (Fibex file)*	Path and name of the FIBEX file for the configuration of the FlexRay controller (MFR)	

* Only for channel 1 of 1x dual

LIN:

LIN > Settings:

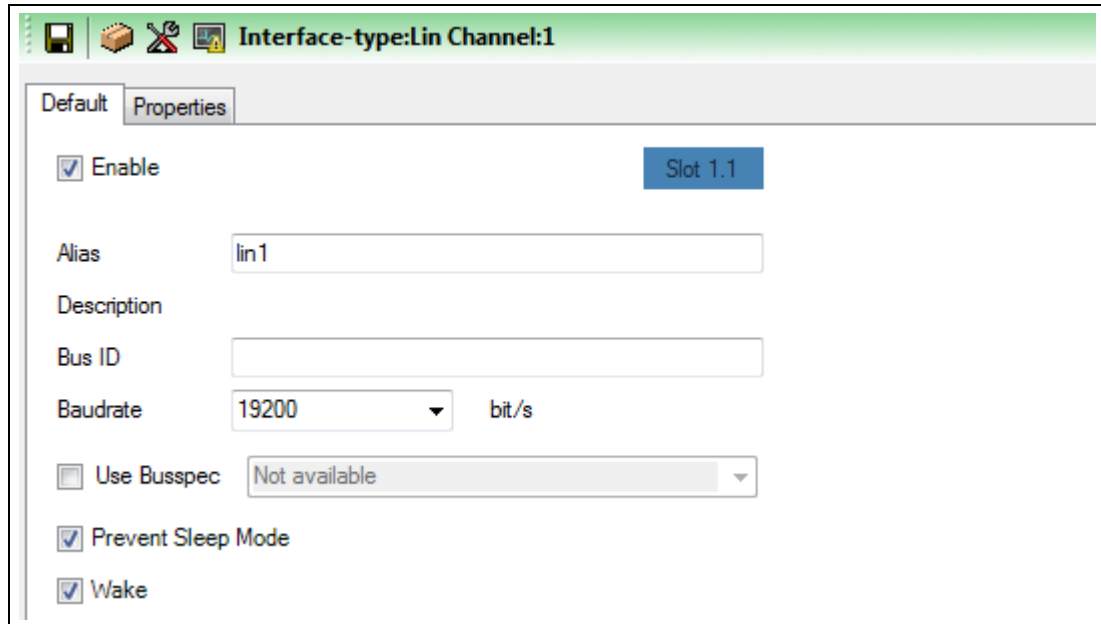

Setting	Description	Default
Enable	Turn on logging for this channel	On
Alias	Freely selectable channel name	lin#
Bus ID	Additional ID for subsequent evaluation	
Baudrate	Transfer rate (in bit/s) Values: 20000, 19200, 9600, 4800, 2400	19200
Use Busspec	Load configuration template provided by the vehicle manufacturer	Off
Prevent Sleep Mode	N4000+ will not go into sleep mode as long as there is activity on this channel	On
Wake	N4000+ wakes up from sleep mode as soon as there is activity on this channel	On

LIN > Trigger:

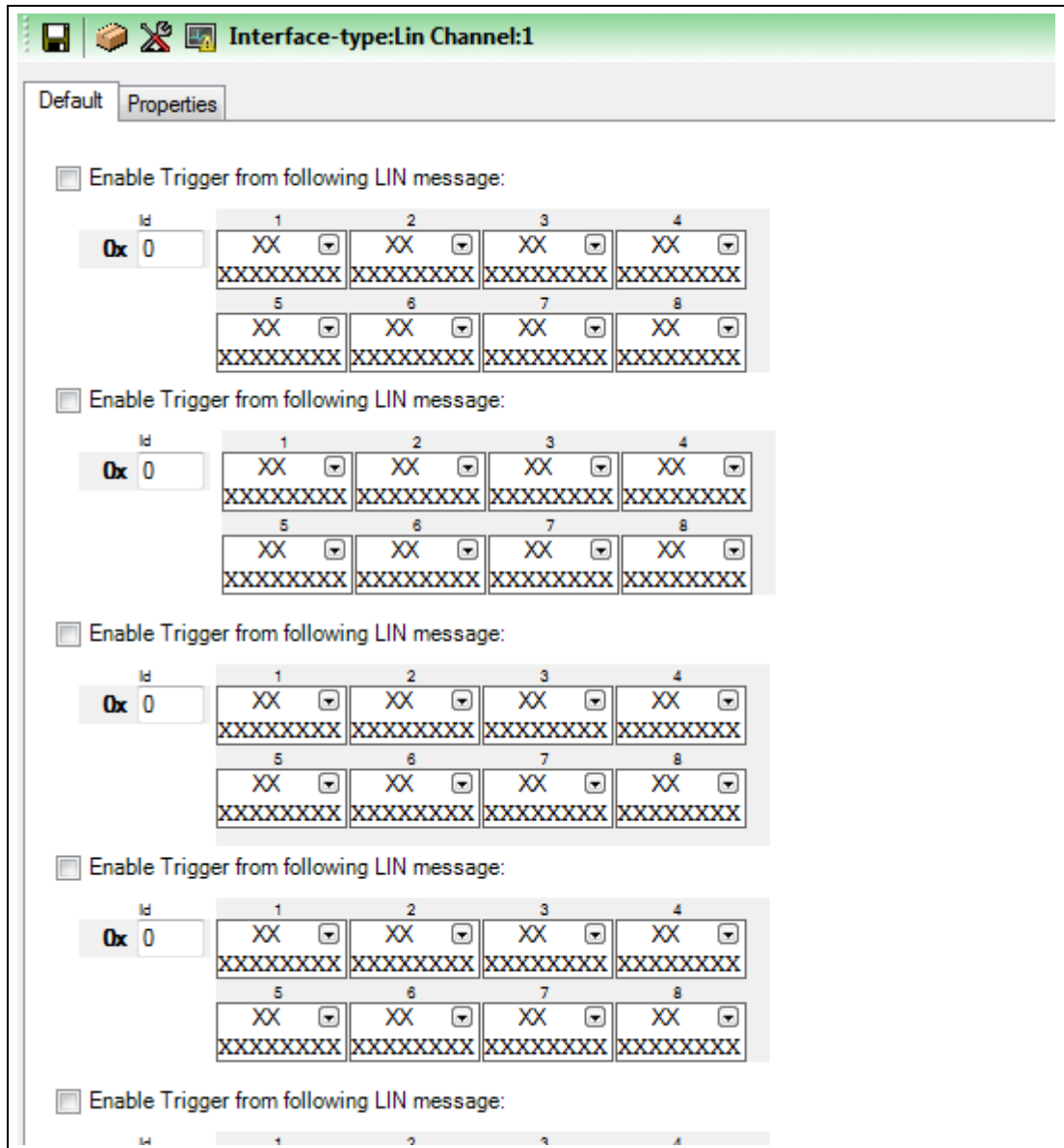

Configure triggers:

- ▶ Select the check box *Enable Trigger from following LIN message*.
- ▶ Under *Id*, specify the ID of the LIN message that raises a trigger. (→ Changing the numbering system)
- ▶ Specify the payload bytes from *1* to *8*. (→ Set bits)
- ▶ Repeat as necessary for up to a total of five triggers.



No trigger response

Because of the missing transmission capability, there are no trigger responses available for the LIN interface.

RS-232:

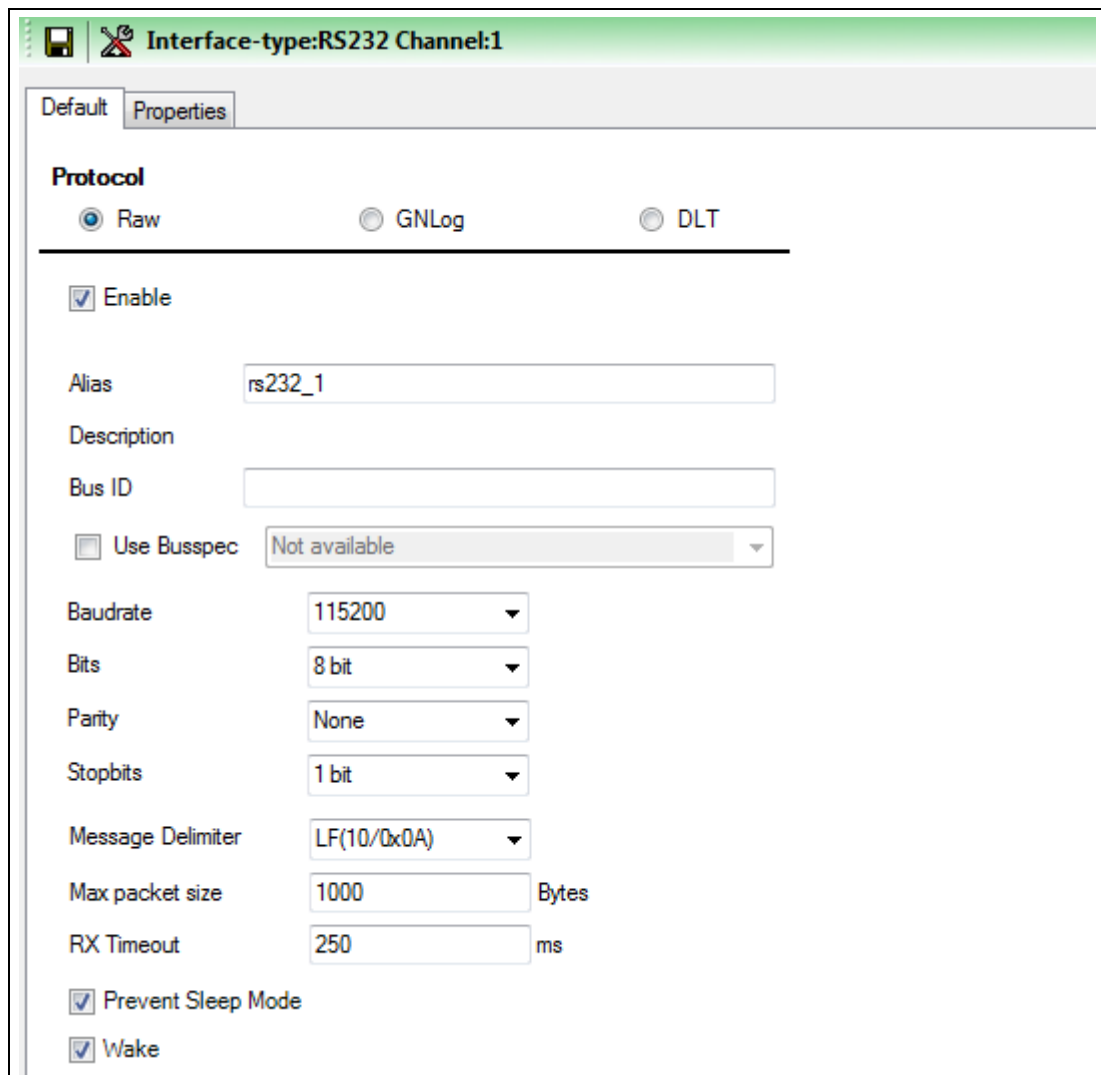

Interface-type:RS232 Channel:1

Default Properties

Protocol

Raw GNLog DLT

Enable

Alias

Description

Bus ID

Use Busspec

Baudrate

Bits

Parity

Stopbits

Message Delimiter

Max packet size Bytes

RX Timeout ms

Prevent Sleep Mode

Wake

Setting	Description	Default
Protocol	<i>Raw, GNLog or DLT</i>	Raw
Enable	Turn on logging for this channel	On
Alias	Freely selectable channel name	rs232_# or gnlog# or DLT#
Bus ID	Additional ID for subsequent evaluation	
Use Busspec	Load configuration template provided by the vehicle manufacturer	Off
Debug level**	Detail level of the debug information GNLog: 0 to 3 (max) DLT: 0 (None) to 6 (Verbose)	GNLog: 2 DLT: 0 (None)
Trace state***	Send trace messages	Off
Verbose mode***	<i>Off</i> : Send only dynamic data <i>On</i> : Send dynamic and static data	Off
Baudrate	Transfer rate (in bit/s) Values: 4800, 9600, 19200, 38400, 57600, 115200, 230400	115200
Bits	Number of data bits of a data block Values: 5 bit, 6 bit, 7 bit, 8 bit	8 bit
Parity	Parity check for error detection Values: None, Odd, Even	None
Stopbits	Number of stop bits that mark the end of a data block Values: 1 bit, 2 bit	1 bit
keep low level data stream**	Underlying RS-232 data are saved	Off
Message Delimiter*	Delimiter that marks the end of a message Values: LF(10/0x0A) = end of line, None	LF(10/0x0A)
Max packet size*	Maximum packet size (in Bytes)	1000
RX Timeout*	If no new character is received during this period (in ms), then the previously received data are interpreted as completed message <i>0</i> : Function disabled	250
Prevent Sleep Mode	N4000+ will not go into sleep mode as long as there is activity on this channel	On
Wake*	N4000+ wakes up from sleep mode as soon as there is activity on this channel	On

* Only for Raw

**Only for GNLog and DLT

***Only for DLT

Ethernet:

Ethernet > Settings:

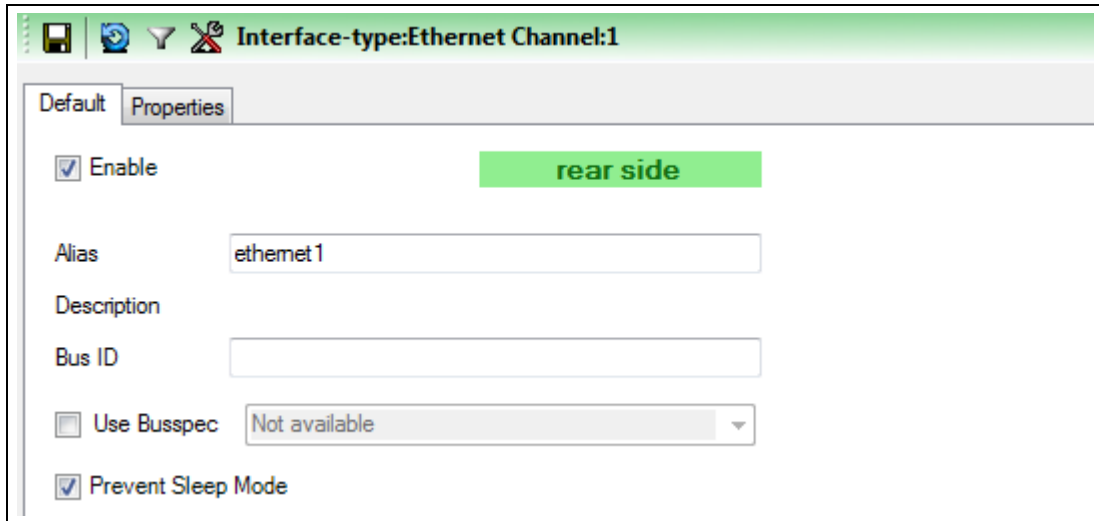

Setting	Description	Default
Enable	Turn on logging for this channel	On
Alias	Freely selectable channel name	ethernet#
Bus ID	Additional ID for subsequent evaluation	
Use Busspec	Load configuration template provided by the vehicle manufacturer	Off
Prevent Sleep Mode	N4000+ will not go into sleep mode as long as there is activity on this channel	On

Ethernet > Filter:

1	Add pre-filter	4	Increase pre-filter priority
2	Delete pre-filter	5	Decrease pre-filter priority
3	Save pre-filter		

The filter is executed in two successive steps:

- Pre-filter MAC address
- Queue dispatching filter EtherType and VLAN

Configure pre-filters:

- ▶ Click *Add pre-filter (1)*.
- ▶ Choose the *Filter type* (only *MAC* is available at the current development stage).
- ▶ Under *Direction*, choose if the filter applies to a participant who is *Source* and/or *Target*.
- ▶ Under *Operator*, choose if the filter is added to the whitelist (==) or the blacklist (!=).
- ▶ Specify the *MAC address*.
- ▶ Click *Save pre-filter (3)*.
- ▶ Repeat as necessary for further pre-filters.



Priorities of pre-filters

Change the priorities of the pre-filters with the buttons (4) and (5).

The XORAYASuite applies the first pre-filter from the top that matches the condition. The other pre-filters are ignored.

The N4000+ processes packet data in Online mode and HDD mode via the so-called default-queue. In the stream-queue, only HDD mode recording is possible, and streaming data are directly stored without creating statistics.

The queue dispatching filter compares *EtherType* and both VLAN tags (*InnerTag*, *OuterTag*) of received Ethernet frames with the bytes specified here. (→ Set bits)

If all selected filter conditions are matched, the Ethernet frame is assigned to the streaming data, otherwise to the packet data. If the Ethernet frame contains no or only one VLAN tag, the filter conditions for the non-existing fields are ignored.

Via *Load presets*, you can configure filter conditions in such way that either all frames are assigned to streaming data (*Streaming logging only*) or all frames to packet data (*Packet logging only*).

Setting	Description	Default
EtherType	Expected result of the check on the EtherType field if matching	0x0
TPID (InnerTag)	Tag protocol identifier of the inner VLAN tag for Ethernet frames (always 0x8100)	0x8100
TCI (InnerTag)	Expected result of the check on the inner VLAN tag if matching	0x0
TPID (OuterTag)	Tag protocol identifier of the outer VLAN tag for Ethernet frames Values: 0x88A8, 0x9100, 0x9200, 0x9300	0x88A8
TCI (OuterTag)	Expected result of the check on the outer VLAN tag if matching	0x0
NOT	Invert filter condition	Off
Enable packet logging	Record filtered packet data	On
Enable streaming logging	Record filtered streaming data	On

Ethernet protocols:

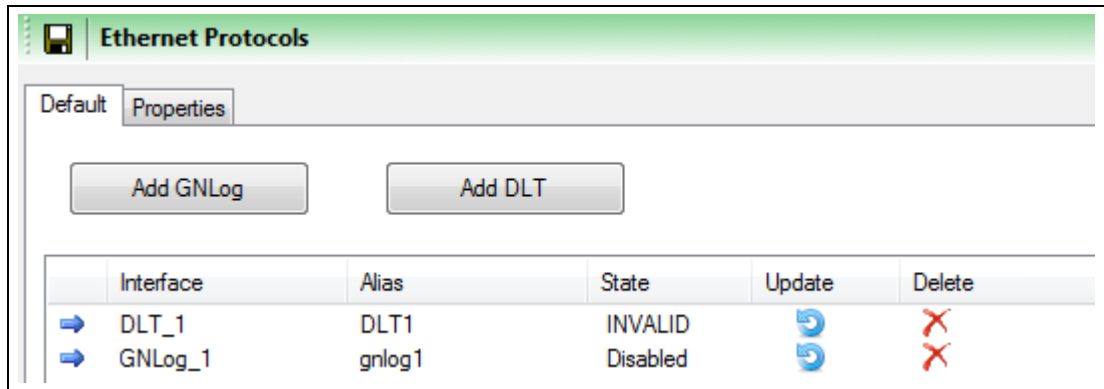

In this configuration section, you can add, update and delete GNLog and DLT channels. Both protocols are recorded via the LAN host ports or the BroadR-Reach interface.

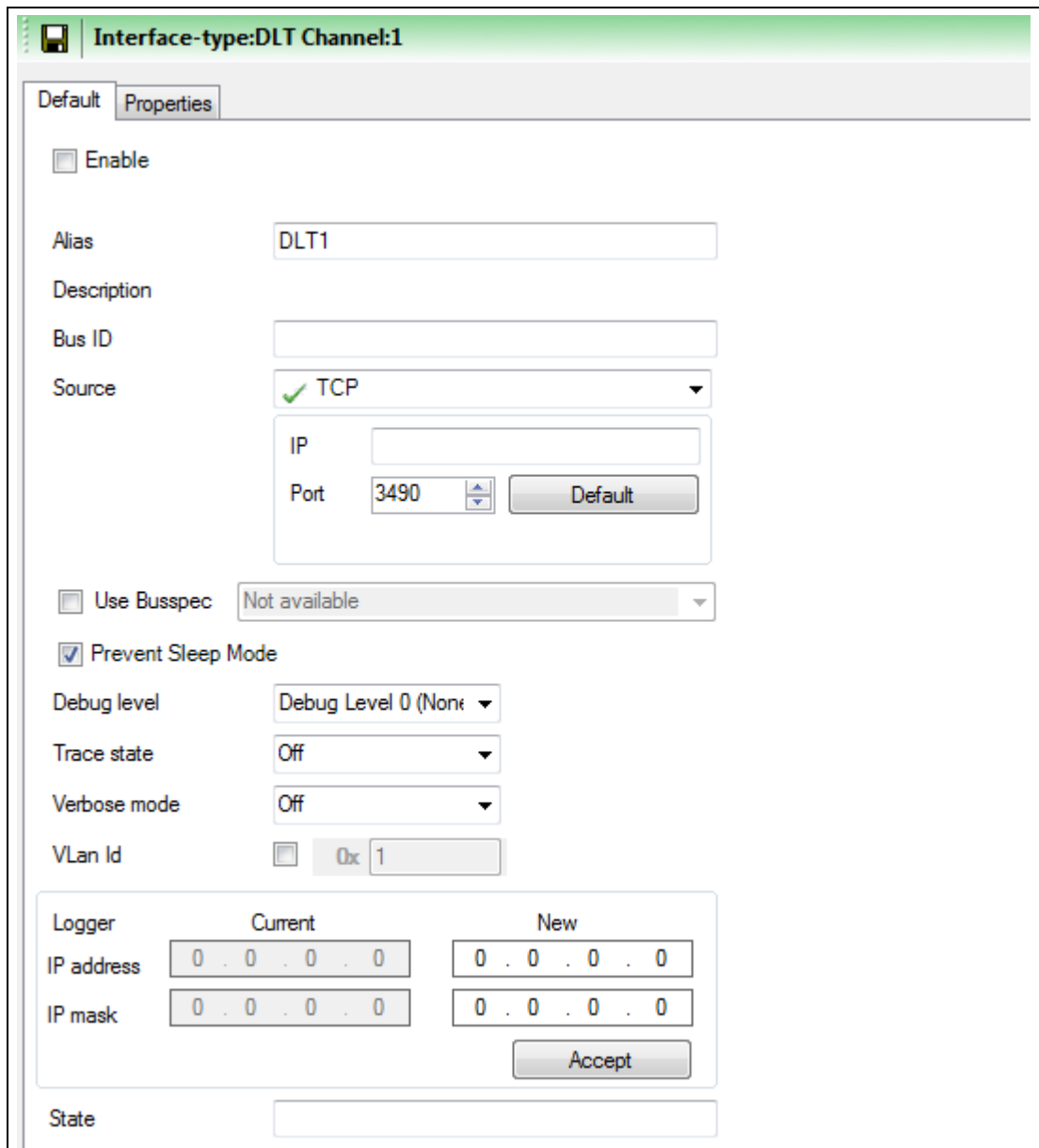

Setting	Description	Default
Enable	Turn on logging for this channel	Off
Alias	Freely selectable channel name	gnlog# or DLT#
Bus ID	Additional ID for subsequent evaluation	
Source	TCP (GNLog, DLT) or UDP (only DLT) IP address and port of the ECU <i>Default</i> sets the port to 851 (GNLog) or 3490 (DLT)	
Use Busspec	Load configuration template provided by the vehicle manufacturer	Off
Prevent Sleep Mode	N4000+ will not go into sleep mode as long as there is activity on this channel	On
Debug level	Detail level of the debug information GNLog: 0 to 3 (max) DLT: 0 (None) to 6 (Verbose)	GNLog: 2 DLT: 0 (None)
Trace state*	Send trace messages	Off
Verbose mode*	<i>Off</i> : Send only dynamic data <i>On</i> : Send dynamic and static data	Off
VLAN Id	Check box activates VLAN ID according to IEEE 802.1Q Values: 1 to 4095	1
IP address	IP address which the N4000+ uses in the communication with the ECU	0.0.0.0
IP mask	Network mask which the N4000+ uses in the communication with the ECU	0.0.0.0

* Only for DLT

VIDEO:

Connect camera:

- ▶ Connect the camera to one of the Ethernet log interfaces (**N/P**).
(→ Connections and controls)
- ▶ Connect another Ethernet log interface (**N/P**) to one of the LAN host ports (**E**).
- ▶ Connect another LAN host port (**E**) to the PC.

Control video recordings:

- ▶ Create one or multiple signal-based triggers of the VIDEO interface.
or
- ▶ Activate one or multiple trigger actions of the button interface that effect the video recording. (→ Button)



INTERFACE_NET_CAMERA

This licence is required for video recordings.

Check in category *Versions* of system settings to verify which licences are activated for your N4000+.
(→ Versions)

VIDEO > Settings:

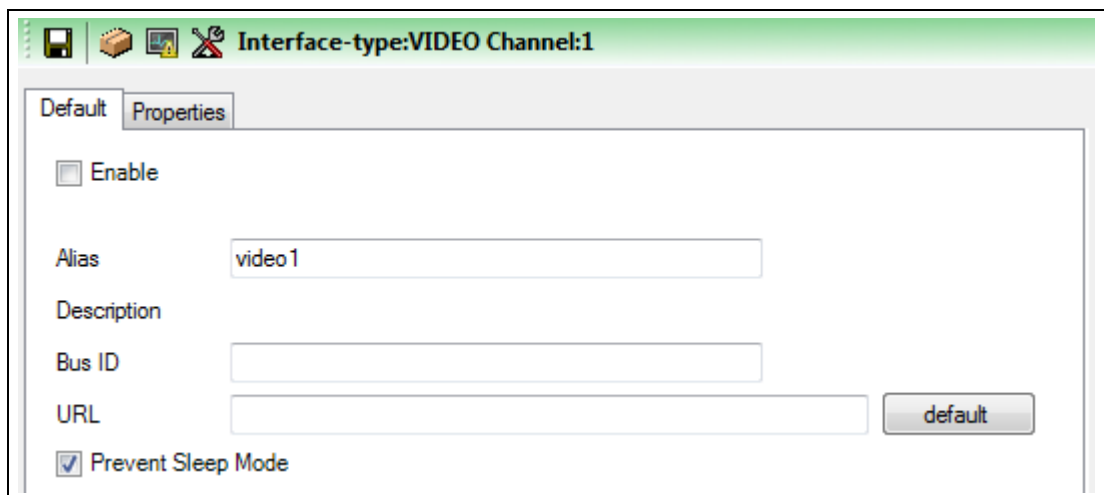

Setting	Description	Default
Enable	Turn on logging for this channel	Off
Alias	Freely selectable channel name	video#
Bus ID	Text box <i>Bus ID</i> Additional ID for subsequent evaluation	
URL	To control an IP camera <i>default</i> enters the sample configuration of a Basler camera	
Prevent Sleep Mode	N4000+ will not go into sleep mode as long as there is activity on this channel	On

VIDEO > Trigger:

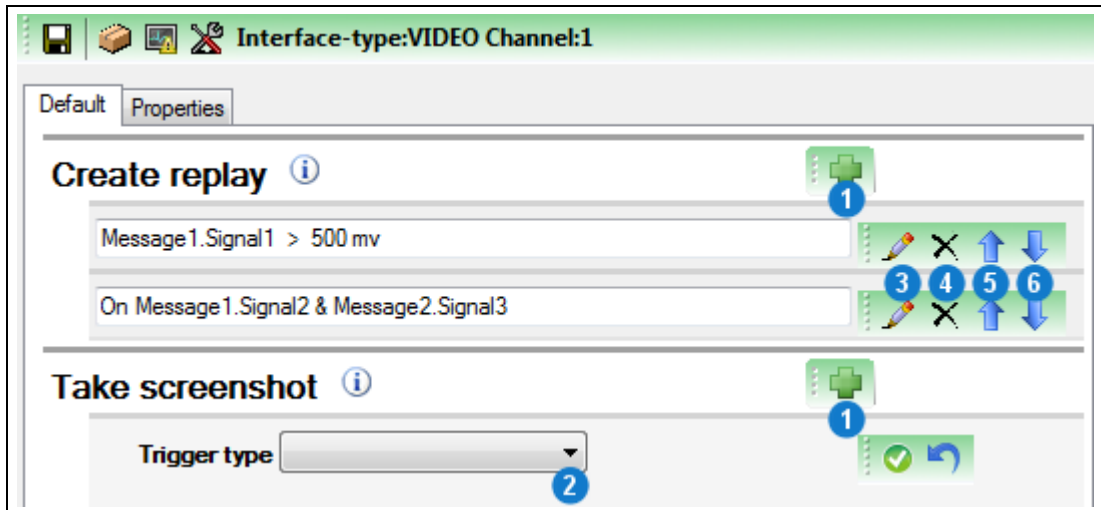

1	Add trigger	4	Delete trigger
2	Trigger type	5	Move trigger up
3	Edit trigger	6	Move trigger down

Here, you create conditions that trigger the following pre-defined actions:

- Create replay (the video stream currently stored in the circular buffer is saved permanently)
- Take screenshot
- Start Stream
- Stop Stream

Configure triggers:

- ▶ On the header of the desired trigger action, click *Add trigger* (1).
- ▶ Select the desired *Trigger type* (2).
- ▶ Create a single condition or multiple combined conditions for this trigger. (→ Create trigger conditions)
- ▶ If required, repeat the above steps for further triggers.



Number of configurable triggers

You can configure a maximum of ten triggers per VIDEO interface channel.

DiagCCP:

DiagCCP > Settings:

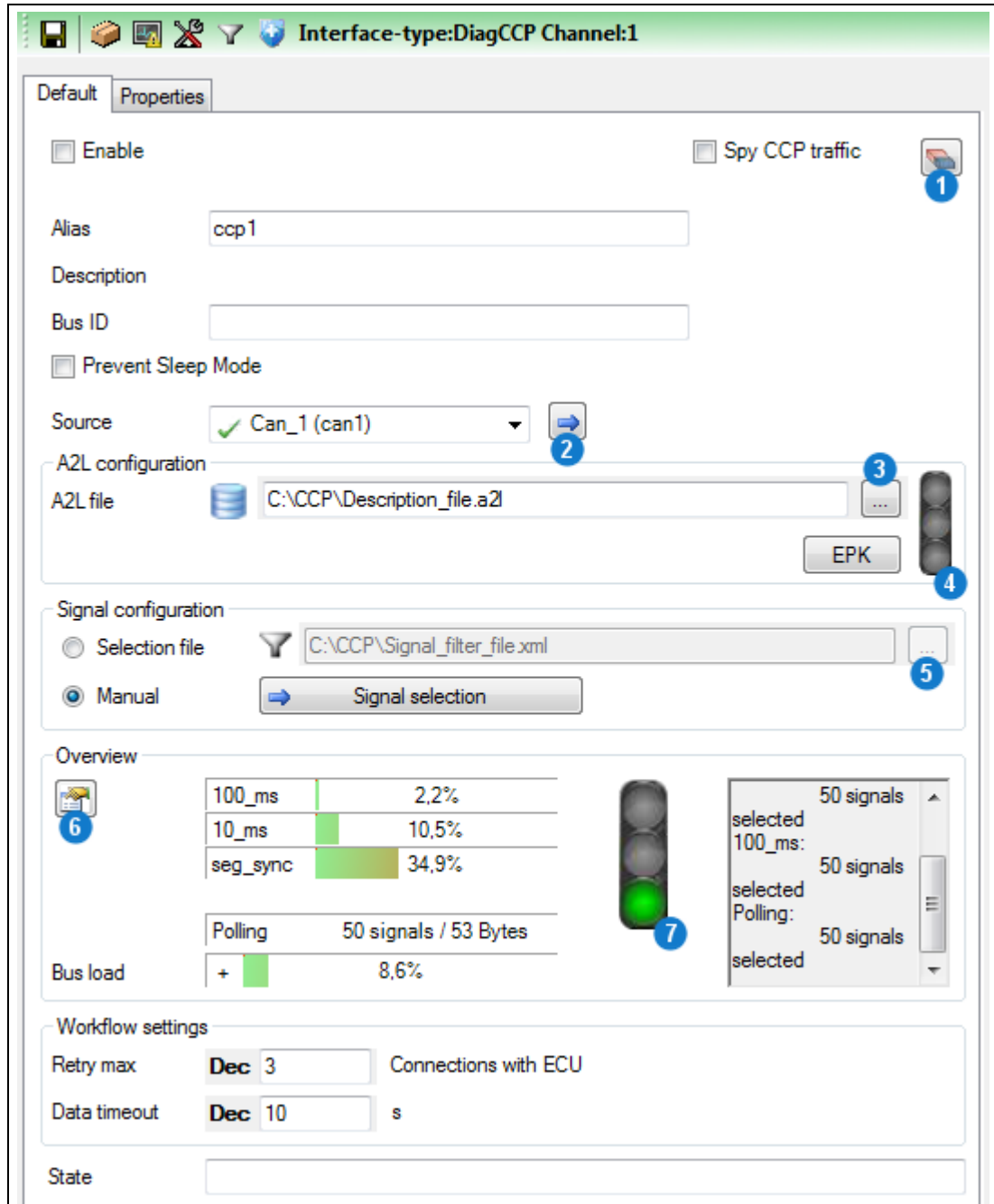

1	Clear all settings	5	Open selection file
2	Edit CAN interface channel	6	Settings
3	Open A2L file	7	Traffic light for the bus load
4	Traffic light for the EPK check		



PROTOCOL_CCP
PROTOCOL_CCP_SPY

The available modes (Master, Spy) depend on the activation of these licences.

Check in category *Versions* of system settings to verify which licences are activated for your N4000+.
(→ Versions)

Setting	Description	Default
Enable	Turn on logging for this channel	Off
Spy CCP traffic	CCP mode <i>On</i> : Spy (external communication is monitored, no sending) <i>Off</i> : Master	Off
Alias	Freely selectable channel name	ccp#
Bus ID	Additional ID for subsequent evaluation	
Prevent Sleep Mode	N4000+ will not go into sleep mode as long as there is activity on this channel	Off
Source	Physical CAN channel to be used	Can_1 (can1)
A2L file	Description file, which is suitable for the ECU and is loaded to configure the CCP connection	
Selection file	Signal filter file (XML, CFG or LAB), which contains a (pre-)selection of the signals to be monitored	
Retry max	Maximum number of retries after unsuccessful connection attempt	3
Data timeout	No data received for this period of time (in s) leads to an error	10

Meaning of the symbols for the physical CAN channels:

- ✓ transmission-capable
- ✓ transmission-capable, but currently set to passive
- ✗ not transmission-capable
- ✗ not enabled

Via *Edit CAN interface channel (2)* button, you can enable it, activate its transmission capability or change its baudrate if necessary.

A2L configuration:

- ▶ Click *Open A2L file* (3) and select the description file that corresponds with the ECU.
- The XORAYASuite reads the A2L file and configures the CCP connection accordingly.
- If *Overwrite alias with ECU name* under *Settings* (6) is activated, *Alias* is also changed.
- If supported by the A2L file, the XORAYASuite automatically runs an EPK version check with the ECU and displays the result via the *Traffic light for the EPK check* (4).

You can also execute this check manually via the *EPK* button.

Levels of the *Traffic light for the EPK check* (4):

- green check successful
- yellow check not possible
- red check not successful

Signal configuration:

- ▶ Click *Open selection file* (5) and select a suitable XML, CFG or LAB file.
or
- ▶ Click *Signal selection* and select the signals manually. (→ Filter)
- The XORAYASuite calculates the expected percentage of the bus load increase.

The result evaluation is displayed via the *Traffic light for the bus load* (7).

Configure the levels of the *Traffic light for the bus load* (7):

- ▶ Right-click on the traffic light and then on *Edit traffic light settings for this interface type*.
- ▶ Specify the percentage limit between green and yellow (standard: 50).
- ▶ Specify the percentage limit between yellow and red (standard: 80).
- ▶ Click *OK*.

DiagCCP > Filter:

The screenshot shows the 'DiagCCP Channel:1' interface. At the top, there are icons for file operations and a search box. Below the search box is a toolbar with icons numbered 1 through 11. The main area contains a table with the following data:

Index	Name	Address	seg_sync	10_ms	100_ms	Polling
0	Signal1	E0010000	<input checked="" type="checkbox"/>	<input type="checkbox"/>	<input type="checkbox"/>	none
1	Signal2	E0020000	<input type="checkbox"/>	<input checked="" type="checkbox"/>	<input type="checkbox"/>	none
2	Signal3	E0030000	<input type="checkbox"/>	<input type="checkbox"/>	<input checked="" type="checkbox"/>	none
3	Signal4	E0040000	<input type="checkbox"/>	<input type="checkbox"/>	<input type="checkbox"/>	1000ms

Below the table is a legend for the numbered callouts:

1	Show all signals	7	Export signals
2	Search box	8	Display CCP main settings
3	Refresh signal list	9	Add polling channel*
4	Display selected signals	10	Status of the signal definition file
5	Clear selected signals	11	Prescaler*
6	Import signals		

* Only if supported by the A2L file

Select signals for the DAQ measurement mode:

- ▶ Select the check box of the signal (row) for the event channel (column).
- or*
- ▶ Highlight one or multiple rows and right-click to activate these signals simultaneously for one event channel.

Select signals for the polling measurement mode:

- ▶ Click *Add polling channel* (9).
The button is inactive if the A2L file does not support polling.
- ▶ In the row of the signal, select the polling cycle from the drop-down list.

Filter signal list:





- ▶ Enter the term or partial term in the search box (2) and click *Refresh signal list* (3).
- or*
- ▶ Click *Display selected signals* (4) to only display signals with selected check boxes or selected polling cycle.

Clear signal list filter:

- ▶ Click *Show all signals* (1).

To allow a later MDF export of the data without A2L file, generate a signal definition file in the *Other* category and save it, optionally encrypted, on the N4000+. (→ Other)

Status of the signal definition file (10) displays the current state of the file and changes its state by clicking:

-  not generated
-  saved on N4000+
-  saved encrypted on N4000+
-  not saved on N4000+

If supported by the A2L file, you can reduce the sampling rate of each event channel by increasing the *Prescaler (11)*.

DiagCCP > Trigger:

1	Add trigger	4	Delete trigger
2	Trigger type	5	Move trigger up
3	Edit trigger	6	Move trigger down

Here, you create conditions that trigger the following pre-defined actions:

- Start CCP logging
- Stop CCP logging



Start and stop without trigger conditions

Even when you do not create trigger conditions, the CCP recording, provided it is activated, starts and stops automatically at the beginning or ending of the data recording in online mode or HDD mode.

Configure triggers:

- ▶ On the header of the desired trigger action, click *Add trigger* (1).
- ▶ Select the desired *Trigger type* (2).
- ▶ Create a single condition or multiple combined conditions for this trigger. (→ Create trigger conditions)
- ▶ If required, repeat the above steps for further triggers.



Number of configurable triggers

You can configure a maximum of ten triggers per DiagCCP interface channel.

DiagCCP > Other:

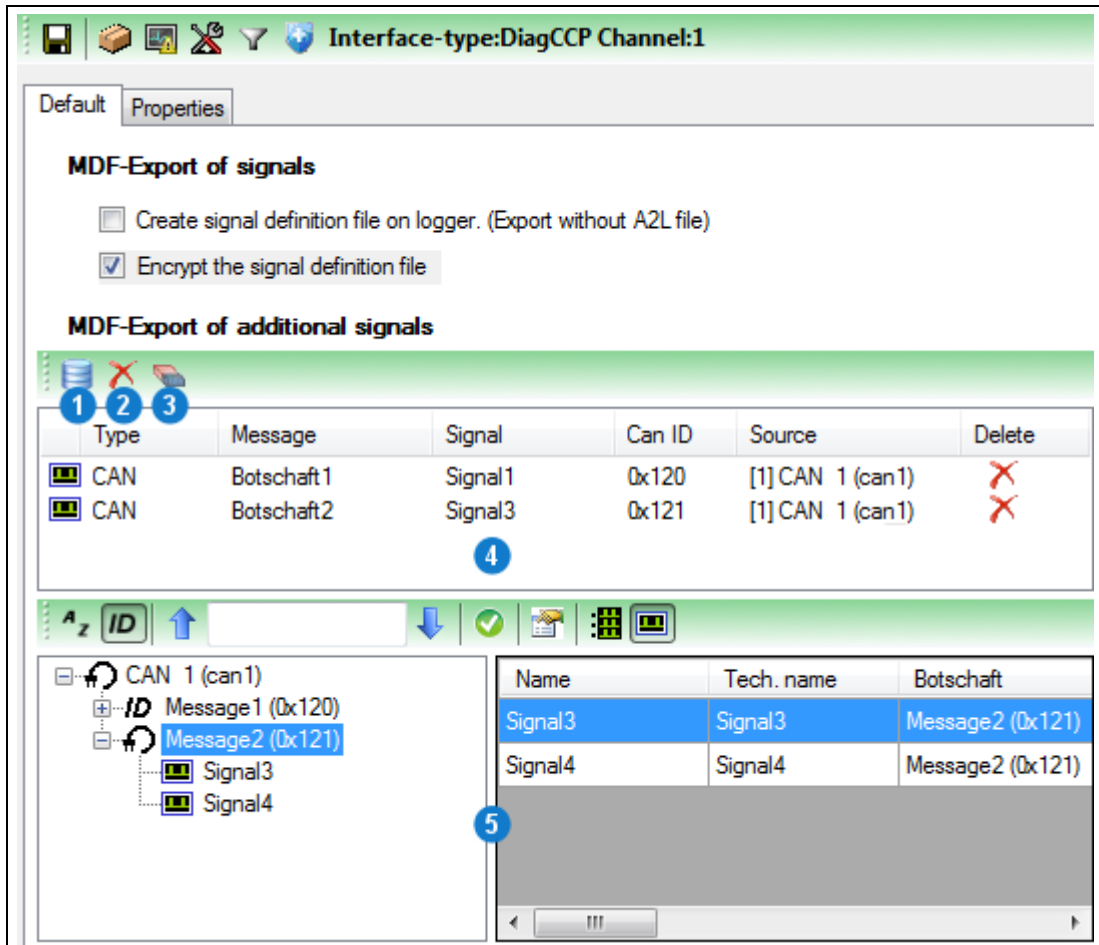

Type	Message	Signal	Can ID	Source	Delete
CAN	Botschaft1	Signal1	0x120	[1] CAN 1 (can1)	X
CAN	Botschaft2	Signal3	0x121	[1] CAN 1 (can1)	X

Name	Tech. name	Botschaft
Signal3	Signal3	Message2 (0x121)
Signal4	Signal4	Message2 (0x121)

1	Show/hide A2L signals	4	Additional signals
2	Delete signal	5	Signal selection
3	Delete signal definition file		

To allow a later MDF export of the data without A2L file, generate a signal definition file as a reduced A2L file and save it, optionally encrypted, on the N4000+.

Create and encrypt the signal definition file by selecting the check boxes under *MDF-Export of signals*.

Add additional signals (4) to the signal definition file by selecting the desired signals (5). (→ Signal selection)

By clicking (1), you also display the signals which are imported from the A2L file.

By clicking (2), you delete the selected signals and with (3) the whole signal definition file.

DiagCCP > Advanced:

Short name	Long name	Number	Rate	Priority	DAQ / STIM
seg_sync	segment synchronous	0	Not Cyclic	3	DAQ
10_ms	10ms time synchronous	1	10 ms	2	DAQ
100_ms	100ms time synchronous	2	100 ms	1	DAQ

1	Add basic structure of the function	3	Execute function
2	Input data		

This category displays an overview of the configured event channels and allows the definition of a seed and key function for the encrypted communication with the ECU.

Create and test the seed and key function:

- ▶ Click *Add basic structure of the function* (1).
- ▶ Insert the algorithm that corresponds with the ECU.
- ▶ Define the *Input data* (2) to test the function.
- ▶ Click *Execute function* (3).

- The XORAYASuite calculates the output data (key) from the input data (seed) and compares it with the key calculated by the ECU.

DiagXCP:

DiagXCP > Settings:

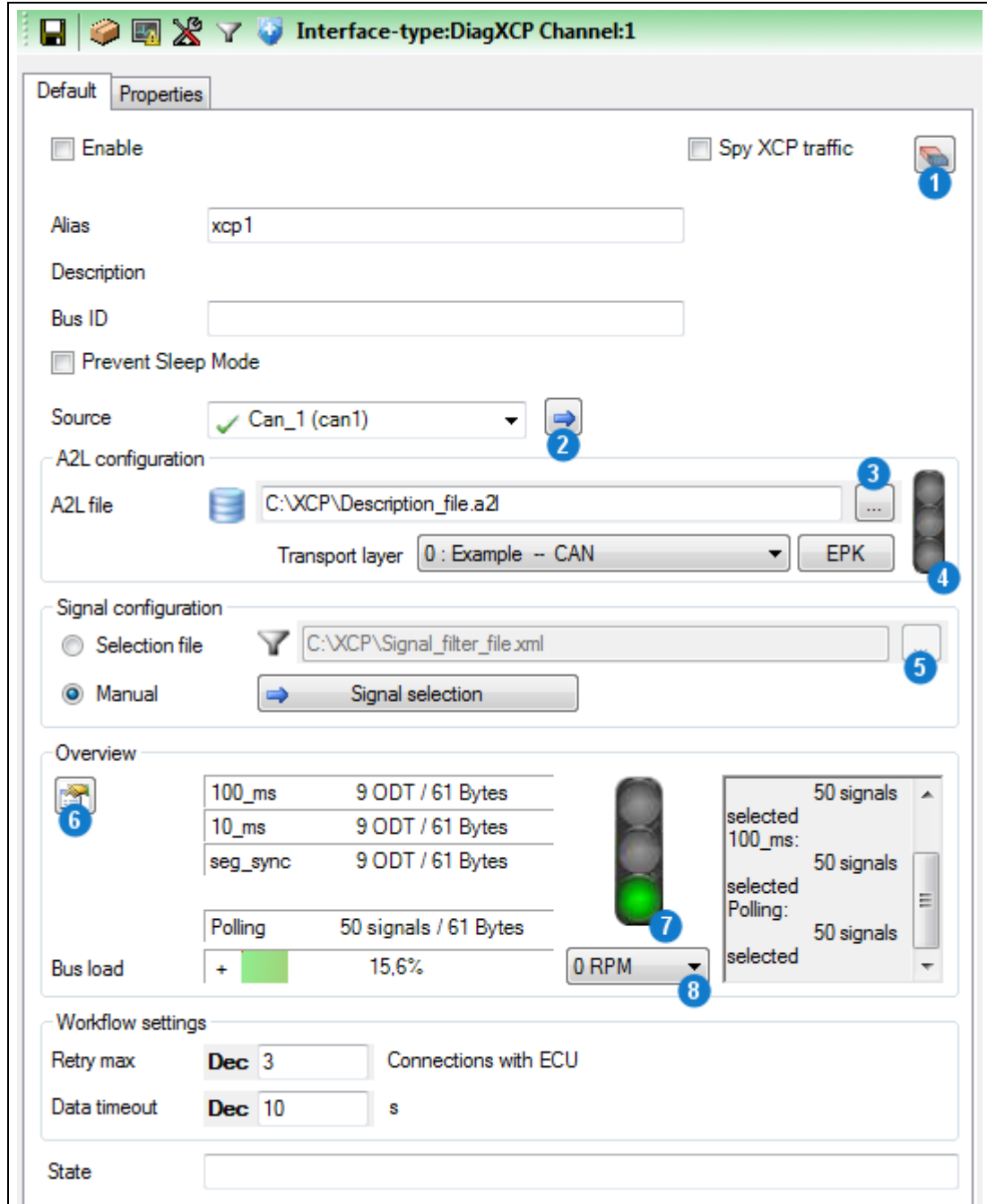

1	Clear all settings	5	Open selection file
2	Edit interface channel	6	Settings
3	Open A2L file	7	Traffic light for the bus load
4	Traffic light for the EPK check	8	Engine RPM*

* Only for angle-synchronous event channels



PROTOCOL_XCP_MASTER
PROTOCOL_XCP_SPY
PROTOCOL_XCP_ON_CAN
PROTOCOL_XCP_ON_FLEXRAY

The available modes (Master, Spy) and physical buses (CAN, FlexRay) depend on the activation of these licences.

Check in category *Versions* of system settings to verify which licences are activated for your N4000+.
 (→ Versions)

Setting	Description	Default
Enable	Turn on logging for this channel	Off
Spy XCP traffic	XCP mode <i>On</i> : Spy (external communication is monitored, no sending) <i>Off</i> : Master	Off
Alias	Freely selectable channel name	xcp#
Bus ID	Additional ID for subsequent evaluation	
Prevent Sleep Mode	N4000+ will not go into sleep mode as long as there is activity on this channel	Off
Source	Physical CAN or FlexRay channel to be used	Can_1 (can1)
A2L file	Description file, which is suitable for the ECU and is loaded to configure the XCP connection	
Transport layer	Selection if the A2L contains multiple transport layer descriptions	
Selection file	Signal filter file (XML, CFG or LAB), which contains a (pre-)selection of the signals to be monitored	
Retry max	Maximum number of retries after unsuccessful connection attempt	3
Data timeout	No data received for this period of time (in s) leads to an error	10

Meaning of the symbols for the available CAN or FlexRay channels:

- ✓ transmission-capable
- ✓ transmission-capable, but currently set to passive
- ✗ not transmission-capable (only for CAN)
- ✗ not enabled

Via *Edit interface channel (2)* button, you can enable it, activate its transmission capability or change its baudrate if necessary.

A2L configuration:

- ▶ Click *Open A2L file (3)* and select the description file that corresponds with the ECU.

- The XORAYASuite reads the A2L file and configures the XCP connection accordingly.

- If *Overwrite alias with ECU name* under *Settings (6)* is activated, *Alias* is also changed.

- ▶ If the A2L contains multiple transport layer descriptions, select the layer from the appearing window.

You can change this selection afterwards via the drop-down list *Transport layer*.

- ▶ If the time value T7 is equal to 0, increase this value in the appearing window to avoid protocol errors with the ECU.

You can change this value and all the other time values in the category *Advanced*. (→ *Advanced*)

- If supported by the A2L file, the XORAYASuite automatically runs an EPK version check with the ECU and displays the result via the *Traffic light for the EPK check (4)*.

You can also execute this check manually via the *EPK* button.

Levels of the *Traffic light for the EPK check (4)*:

- green check successful
- yellow check not possible
- red check not successful

Signal configuration:

- ▶ Click *Open selection file (5)* and select a suitable XML, CFG or LAB file.
or
- ▶ Click *Signal selection* and select the signals manually. (→ Filter)
 - The XORAYASuite calculates the expected percentage of the bus load increase.
The result evaluation is displayed via the *Traffic light for the bus load (7)*.
- ▶ If angle-synchronous (RPM-dependent) event channels are used, select the *Engine RPM (8)*, which influences the bus load calculation.

Configure the levels of the *Traffic light for the bus load (7)*:

- ▶ Right-click on the traffic light and then on *Edit traffic light settings for this interface type*.
- ▶ Specify the percentage limit between green and yellow (standard: 50).
- ▶ Specify the percentage limit between yellow and red (standard: 80).
- ▶ Click *OK*.

DiagXCP > Filter:

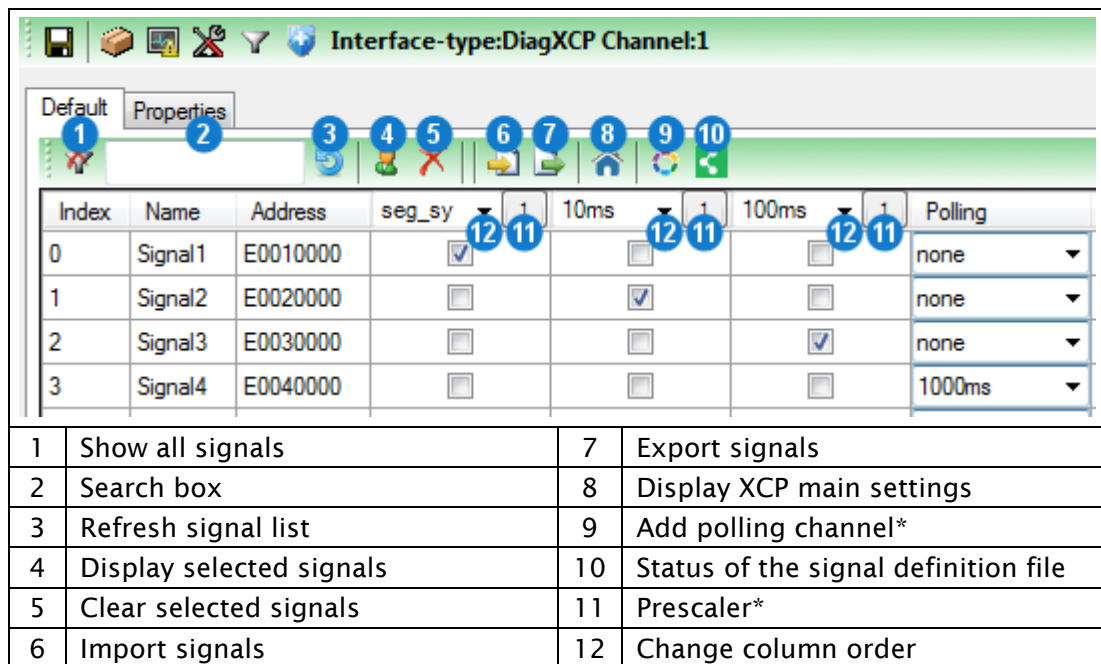

Index	Name	Address	seg_sy	10ms	100ms	Polling
0	Signal1	E0010000	<input checked="" type="checkbox"/>	<input type="checkbox"/>	<input type="checkbox"/>	none
1	Signal2	E0020000	<input type="checkbox"/>	<input checked="" type="checkbox"/>	<input type="checkbox"/>	none
2	Signal3	E0030000	<input type="checkbox"/>	<input type="checkbox"/>	<input checked="" type="checkbox"/>	none
3	Signal4	E0040000	<input type="checkbox"/>	<input type="checkbox"/>	<input type="checkbox"/>	1000ms

1	Show all signals	7	Export signals
2	Search box	8	Display XCP main settings
3	Refresh signal list	9	Add polling channel*
4	Display selected signals	10	Status of the signal definition file
5	Clear selected signals	11	Prescaler*
6	Import signals	12	Change column order

* Only if supported by the A2L file

Select signals for the DAQ measurement mode:

- ▶ Select the check box of the signal (row) for the event channel (column).
- or*
- ▶ Highlight one or multiple rows and right-click to activate these signals simultaneously for one event channel.

Select signals for the polling measurement mode:

- ▶ Click *Add polling channel* (9).
The button is inactive if the A2L file does not support polling.
- ▶ In the row of the signal, select the polling cycle from the drop-down list.

Filter signal list:





- ▶ Enter the term or partial term in the search box (2) and click *Refresh signal list* (3).
- or*
- ▶ Click *Display selected signals* (4) to only display signals with selected check boxes or selected polling cycle.

Clear signal list filter:

- ▶ Click *Show all signals* (1).

To allow a later MDF export of the data without A2L file, generate a signal definition file in the *Other* category and save it, optionally encrypted, on the N4000+. (→ Other)

Status of the signal definition file (10) displays the current state of the file and changes its state by clicking:

-  not generated
-  saved on N4000+
-  saved encrypted on N4000+
-  not saved on N4000+

If supported by the A2L file, you can reduce the sampling rate of each event channel by increasing the *Prescaler (11)*.

The column order of the event channels is adjustable via the drop-down lists (12).

DiagXCP > Trigger:

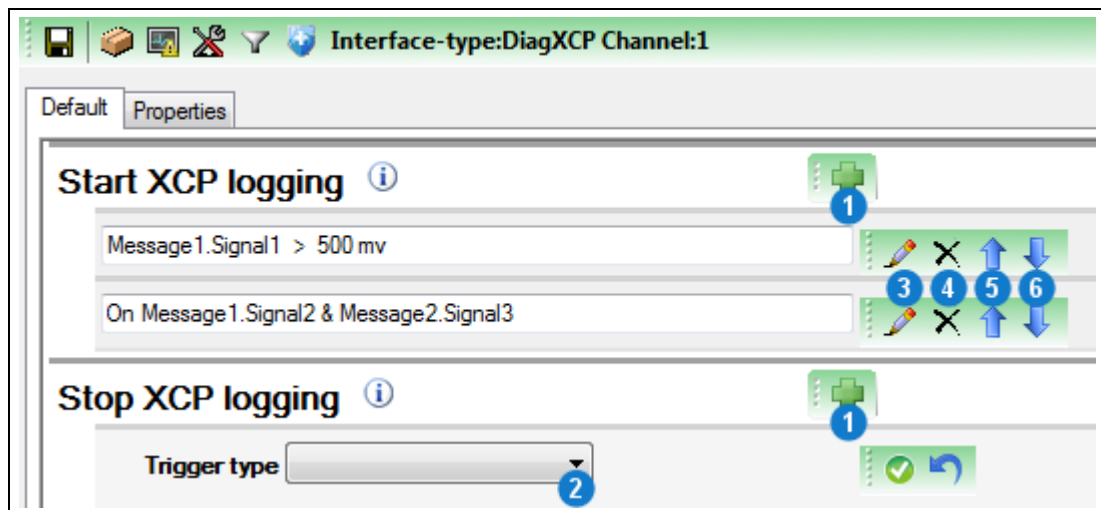

1	Add trigger	4	Delete trigger
2	Trigger type	5	Move trigger up
3	Edit trigger	6	Move trigger down

Here, you create conditions that trigger the following pre-defined actions:

- Start XCP logging
- Stop XCP logging



Start and stop without trigger conditions

Even when you do not create trigger conditions, the XCP recording, provided it is activated, starts and stops automatically at the beginning or ending of the data recording in online mode or HDD mode.

Configure triggers:

- ▶ On the header of the desired trigger action, click *Add trigger* (1).
- ▶ Select the desired *Trigger type* (2).
- ▶ Create a single condition or multiple combined conditions for this trigger. (→ Create trigger conditions)
- ▶ If required, repeat the above steps for further triggers.



Number of configurable triggers

You can configure a maximum of ten triggers per DiagXCP interface channel.

DiagXCP > Other:

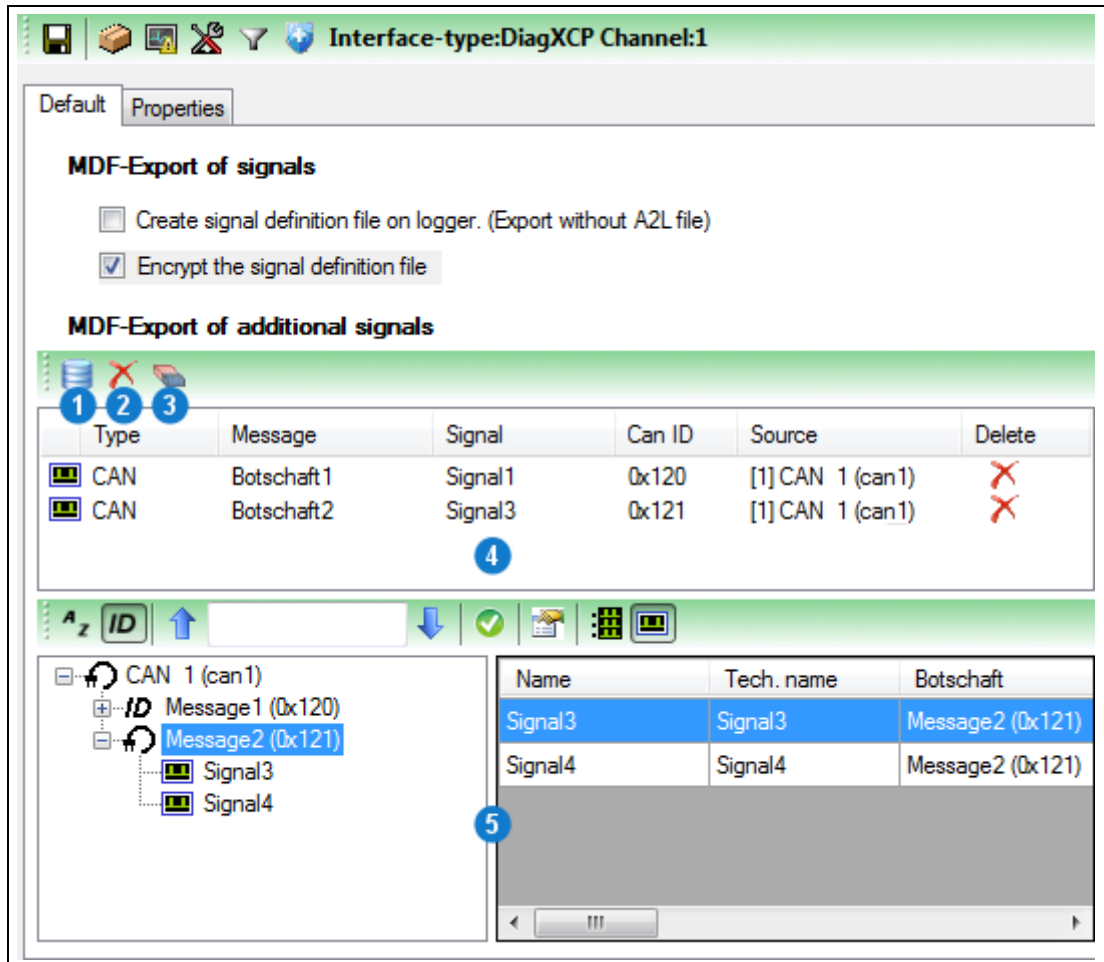

1	Show/hide A2L signals	4	Additional signals
2	Delete signal	5	Signal selection
3	Delete signal definition file		

To allow a later MDF export of the data without A2L file, generate a signal definition file as a reduced A2L file and save it, optionally encrypted, on the N4000+.

Create and encrypt the signal definition file by selecting the check boxes under *MDF-Export of signals*.

Add additional signals (4) to the signal definition file by selecting the desired signals (5). (→ Signal selection)

By clicking (1), you also display the signals which are imported from the A2L file.

By clicking (2), you delete the selected signals and with (3) the whole signal definition file.

DiagXCP > Advanced:

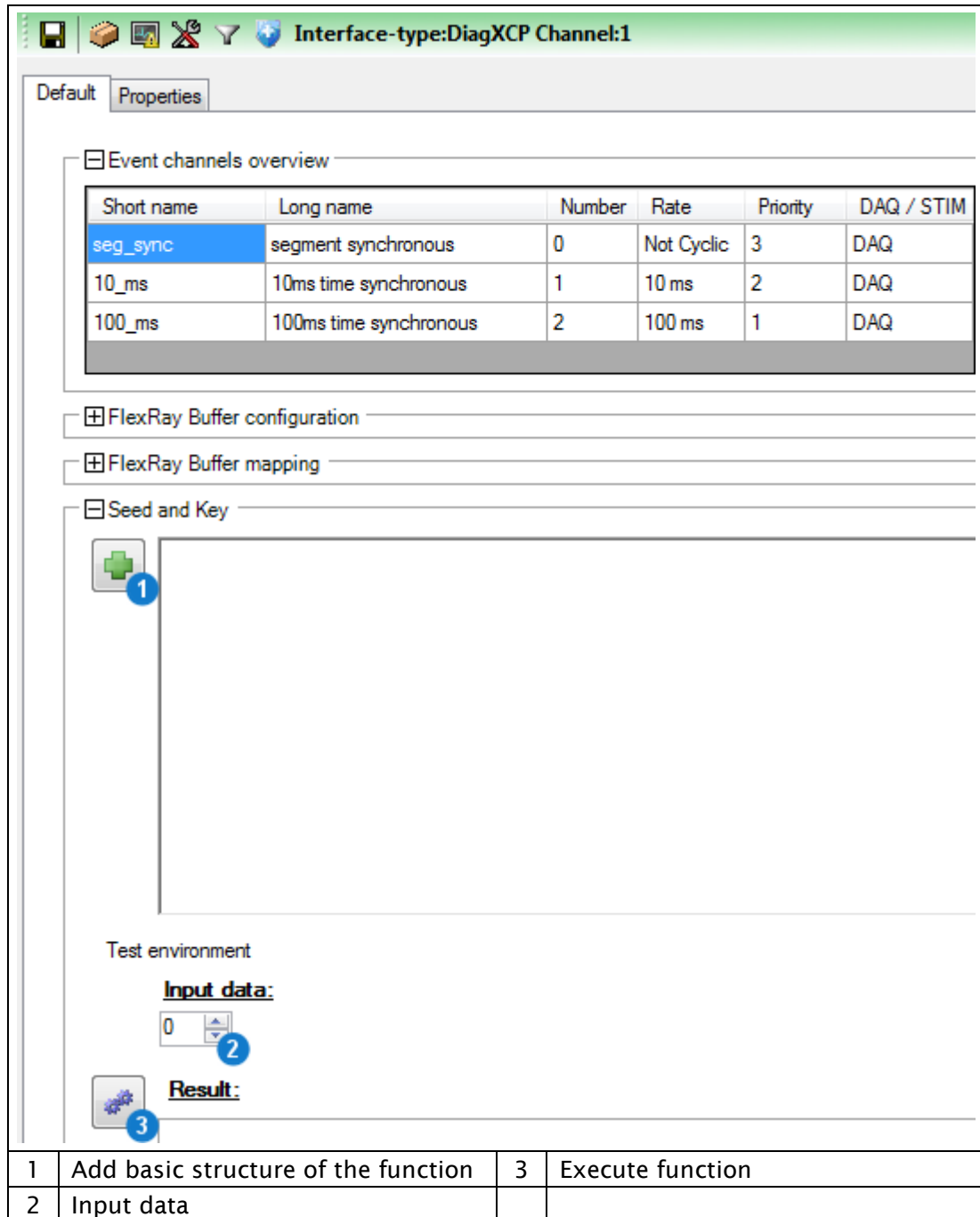

Short name	Long name	Number	Rate	Priority	DAQ / STIM
seg_sync	segment synchronous	0	Not Cyclic	3	DAQ
10_ms	10ms time synchronous	1	10 ms	2	DAQ
100_ms	100ms time synchronous	2	100 ms	1	DAQ

1	Add basic structure of the function	3	Execute function
2	Input data		

This category consists of the following elements:

- Overview of the configured event channels
- Timeout values (changeable)
- FlexRay buffer configuration (partly changeable)
- Mapping of the FlexRay buffers to the event channels (changeable)
- Definition of a seed and key function for the encrypted communication with the ECU

Create and test the seed and key function:

- ▶ Click *Add basic structure of the function (1)*.
 - ▶ Insert the algorithm that corresponds with the ECU.
 - ▶ Define the *Input data (2)* to test the function.
 - ▶ Click *Execute function (3)*.
- The XORAYASuite calculates the output data (key) from the input data (seed) and compares it with the key calculated by the ECU.

Event:

This interface must be activated for proper functioning of:

- Triggers
- Snapshots
- the Button interface

Event > Settings:

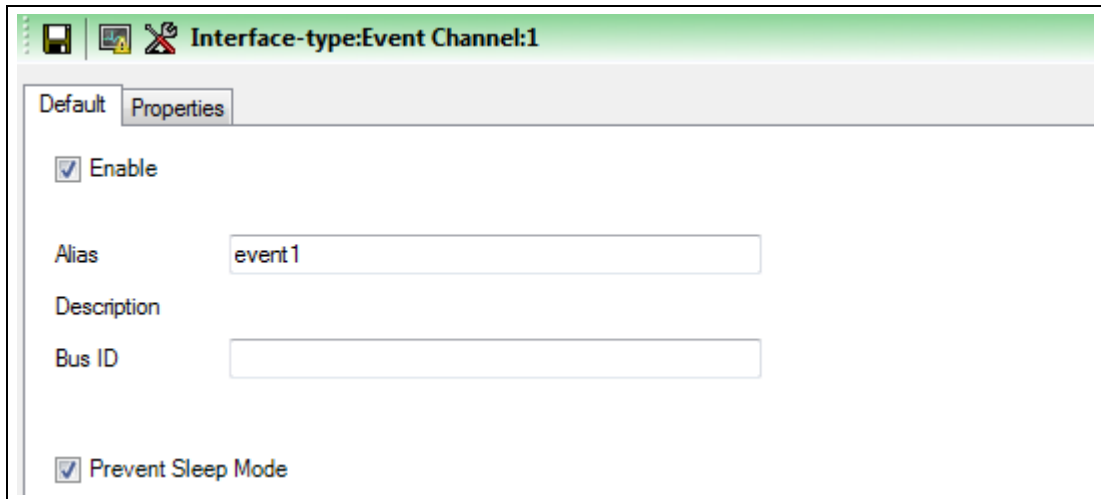

Setting	Description	Default
Enable	Turn on logging for this channel	On
Alias	Freely selectable channel name	event#
Bus ID	Additional ID for subsequent evaluation	
Prevent Sleep Mode	N4000+ will not go into sleep mode as long as there is activity on this channel	On

Event > Trigger:

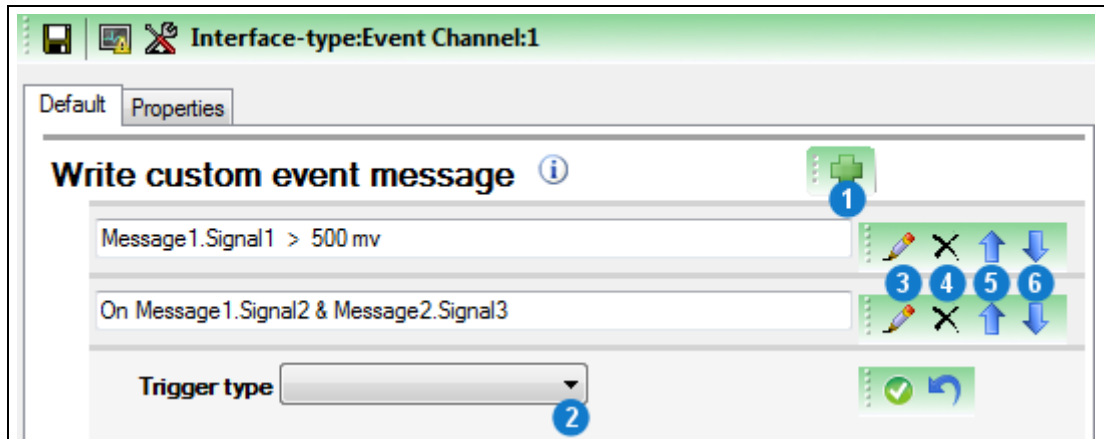

1	Add trigger	4	Delete trigger
2	Trigger type	5	Move trigger up
3	Edit trigger	6	Move trigger down

Here, you create trigger conditions that write custom event messages.

Configure triggers:

- ▶ Click *Add trigger* (1).
- ▶ Select the desired *Trigger type* (2).
- ▶ Create a single condition or multiple combined conditions for this trigger. (→ Create trigger conditions)
- ▶ If required, repeat the above steps for further triggers.



Number of configurable triggers

You can configure a maximum of ten event triggers.

Button:

Use this interface to define which actions are triggered by the following trigger types.

Each trigger type is assigned a channel of the button interface as follows (→ Connections and controls):

- trigger_button Pressing the trigger button **(K)**
- wake_line Signal at the trigger input **(M)**

Actions with a yellow background and a blue outline are enabled.

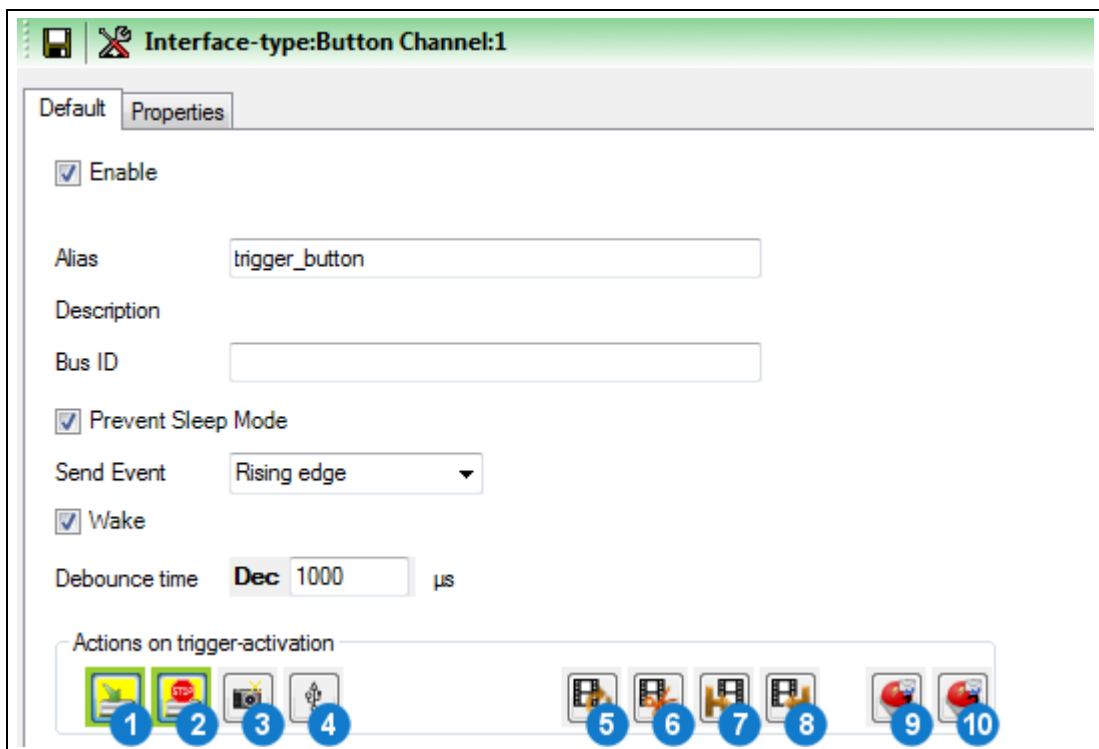

Setting	Description	Default
Enable	Turn on logging for this channel	On
Alias	Freely selectable channel name	trigger_button or wake_line
Bus ID	Additional ID for subsequent evaluation	
Prevent Sleep Mode	N4000+ will not go into sleep mode as long as there is activity on this channel	On
Send Event	Generate an additional event message either at the falling or at the rising edge Values: Falling edge, No event, Rising edge	Rising edge
Wake	N4000+ wakes up from sleep mode as soon as there is activity on this channel	On
Debounce time	Bridging time (in μ s) to prevent undesired multiple events when a trigger is raised	1000
Action (1)	Start logging	On
Action (2)	Stop logging Long press is required (at least 3 s)	On
Action (3)	Create snapshot	Off
Action (4)	Eject USB device Long press is required (at least 3 s)	Off
Action (5)	The video stream currently stored in the circular buffer is saved permanently	Off
Action (6)	Create screenshot	Off
Action (7)	Start video stream	Off
Action (8)	Stop video stream	Off
Action (9)	Send CAN trigger response 1	Off
Action (10)	Send CAN trigger response 2	Off

5.5.3 Signal configuration

In this section, you configure signals and define signal processings and triggers.



Messages and signals

The payload of a message consists of signals with variable bit length.

Messages and signals are assigned names for easier handling.

Settings:

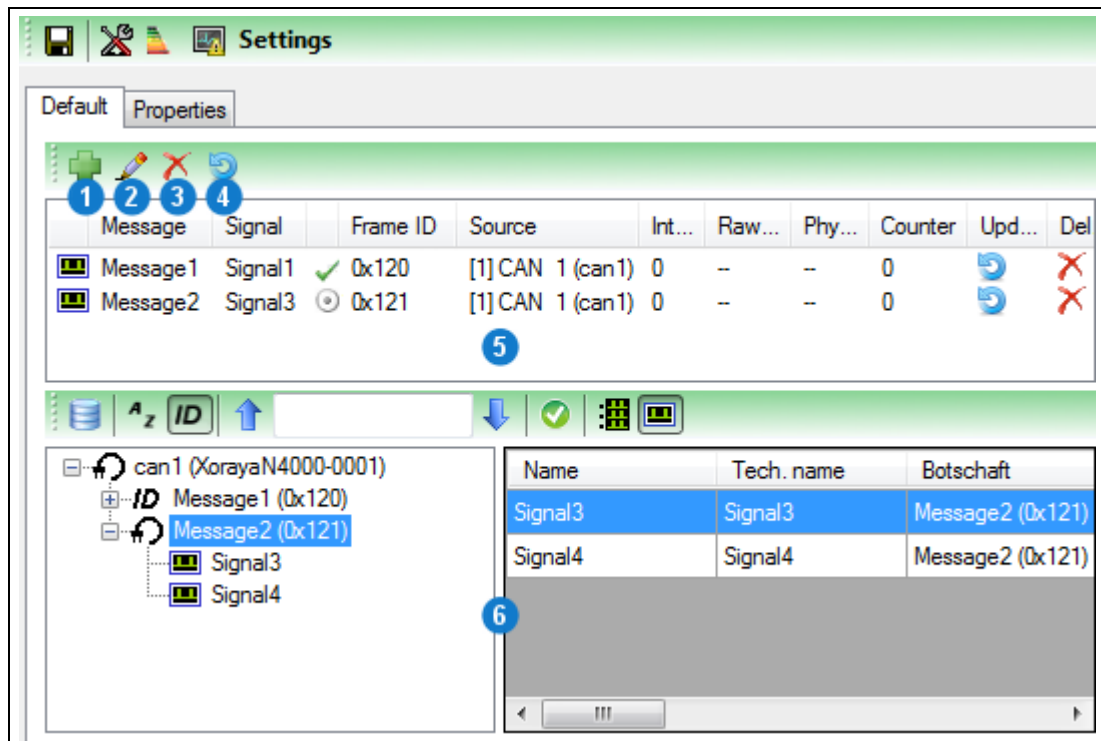

1	Add signal manually	4	Refresh signals
2	Edit signal	5	Configured signals
3	Delete signal	6	Signal selection

Select the desired signals from (6) to add them to the list of configured signals (5). (→ Signal selection)

This list is stored temporarily or permanently on the N4000+.

Click (1) or right-click anywhere in the list (5) to add additional signals manually.

Click (2) or right-click a configured signal in the list (5) to edit this signal.

Signal processing:

Type	Interval	1st signal	2nd signal	Extra	Used / ...	Upd...	Del...
Log	500 ms	Message1.Signal1	--	--	--	↻	✖
Count	1000 ms	Message1.Signal2	--	Binni...	--	↻	✖
Compound	100 ms	Message2.Signal3	Message2.Signal4	Binni...	--	↻	✖

Add the desired signal processing to the list (1).

This list is stored temporarily or permanently on the N4000+.



DATA_BINNING



This licence is required for signal processing.

Check in category *Versions* of system settings to verify which licences are activated for your N4000+. (→ Versions)

Add signal processing:

- ▶ Click *Add signal processing* (2).
- ▶ Select the desired signal processing type.

The following signal processing types are available:

-  Log Only recording, no binning
-  Count Signal binning
-  Compound Combined binning of two signals



Signal binning

Classes reflect signal value ranges. Classification, or binning, allows a quick overview of how often the value of a signal fits into which class during measurement.

Log:

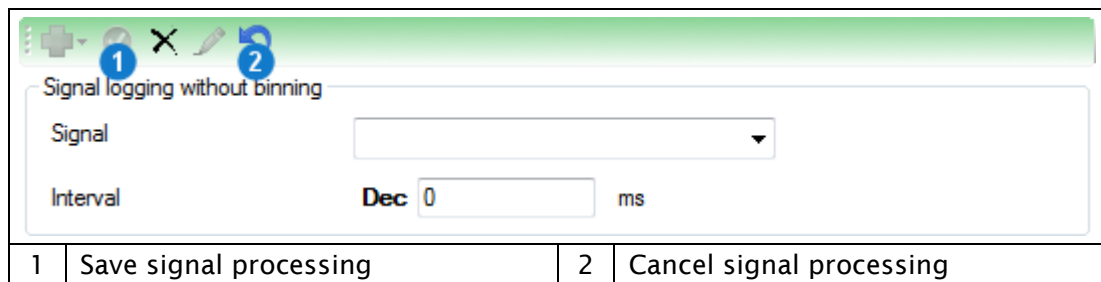

Add signal processing:

- ▶ Select an already configured *Signal*. (→ Settings)
- ▶ Specify the *Interval*.
- ▶ Click *Save signal processing (1)*.

The log signal processing is stored on the N4000+.



Interval of the log signal processing

If you specify an interval, the last measured value of the signal is counted in this time range.

If you do not set an interval (corresponding to a 0 in the text box), the value of the signal is stored on each occurrence.

Count:

Signal logging with simple count binning

Binning name

Signal

Calculation Overview

Assignment way Automatic

	Raw values	Phys. values
Number of classes	Dec 0	unit
Begin	Ox 0	<input type="text"/>
End	Ox 0	<input type="text"/>
Width	Ox 0	<input type="text"/>
Span width	Ox 0	<input type="text"/>

Interval Dec 0 ms

1 Save signal processing 2 Cancel signal processing

Add signal processing count:

- ▶ Specify a *Binning name*.
- ▶ Select an already configured *Signal*. (→ Settings)
- ▶ Select from *Assignment way* which three out of five text boxes, i.e. *Number of classes*, *Begin*, *End*, *Width* and *Span width* you would like to specify.
- or*
- ▶ Select *Automatic* to create classes of constant width uniformly over the entire value range.
- ▶ Complete all active text boxes in the *Calculation* tab.
 - The XORAYASuite calculates the remaining values and fills the text boxes accordingly.
- ▶ Specify the *Interval*.
- ▶ Click *Save signal processing (1)*.
 - The count signal processing is stored on the N4000+.



Interval of count signal processing

If you specify an interval, the first measured value of the signal is counted in this time range.

If you do not set an interval (corresponding to a 0 in the text box), each signal value is counted.

Compound:

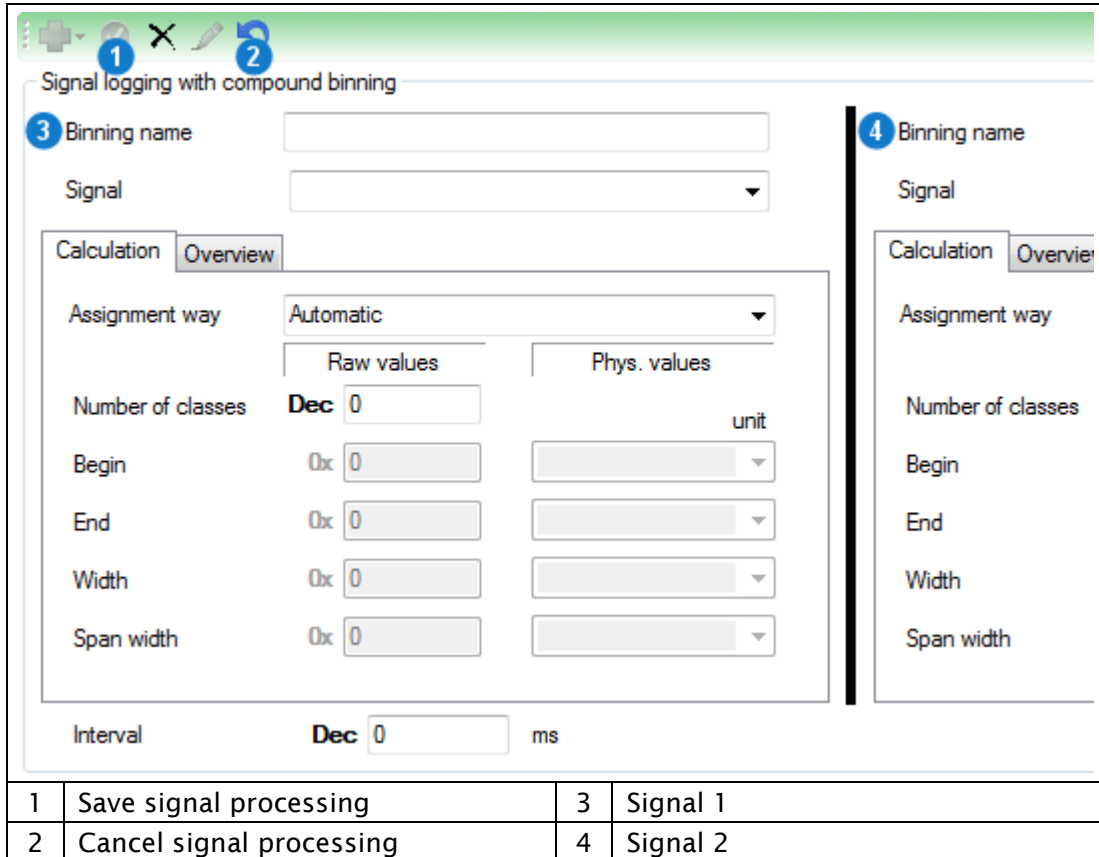

1	Save signal processing	3	Signal 1
2	Cancel signal processing	4	Signal 2

The compound signal processing corresponds to a combined count-signal processing for two signals and is processed by the XORAYASuite as a two-dimensional matrix. Therefore, the total class count is a product of the number of classes for both signals.

Add compound signal processing:

- ▶ Configure the binning for the first signal (3).
- ▶ Configure the binning for the second signal (4).
- ▶ Specify the *Interval*.
- ▶ Click *Save signal processing* (1).

The compound signal processing is stored on the N4000+.

Edit or delete signal processing:

Type	Interval	1st signal	2nd signal	Extra	Used / ...	Upd...	Del...
Log	500 ms	Message 1.Signal1	--	--	--		
Count	1000 ms	Message 1.Signal2	--	Binni...	--		
Compound	100 ms	Message 2.Signal3	Message 2.Signal4	Binni...	--		

Signal logging without binning

Signal:

Interval: Dec ms

1	Configured signal processing	3	Edit signal processing
2	Delete signal processing		

Edit signal processing:

- ▶ Select the signal processing in the list (1).
- ▶ Click *Edit signal processing* (3).
- or*
- ▶ Right-click the signal processing and then click *Edit signal processing*.

Delete signal processing:

- ▶ Select the signal processing in the list (1).
- ▶ Click *Delete signal processing* (2).

Trigger:

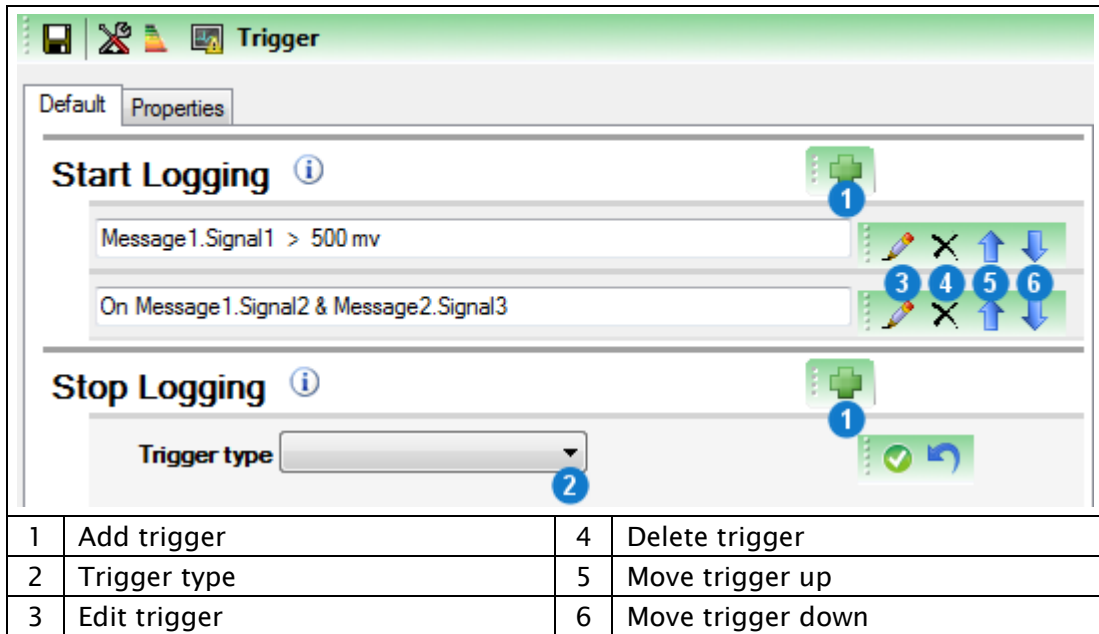

1	Add trigger	4	Delete trigger
2	Trigger type	5	Move trigger up
3	Edit trigger	6	Move trigger down

Here, you create conditions that trigger the following actions:

- Start Logging
- Stop Logging
- Shutdown Logger
- Shut down logger without wake up
- Create Snapshot (→ Snapshot)

Add trigger:

- ▶ On the header of the desired trigger action, click *Add trigger* (1).
- ▶ Select the desired *Trigger type* (2).
- ▶ Create a single condition or multiple combined conditions for this trigger. (→ Create trigger conditions)
- ▶ If required, repeat the above steps for further triggers.



Number of configurable triggers

You can configure a maximum of five general signal triggers.

5.6 Resetting to factory defaults

For unwanted or defective system or interface configurations, it is recommended to reset the N4000+ back to its factory defaults.

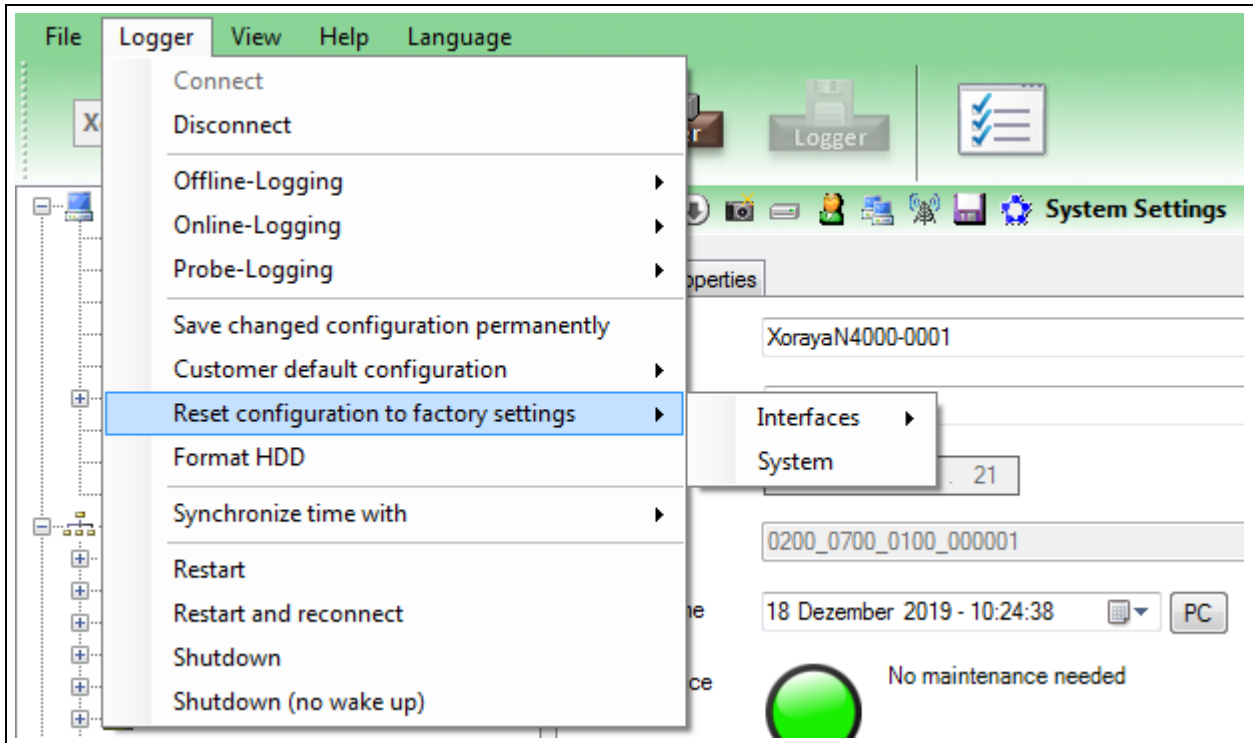

- ▶ In the *Logger* menu, click *Reset configuration to factory settings* to reset the system configuration or one or all interfaces to their factory defaults.

or

- ▶ Press the default button (**D**) for at least 3 seconds to reset all N4000+ settings. (→ Connections and controls)

The N4000+ goes into idle state by way of confirmation.

- The configuration is reset.



Updating the firmware

Factory setting are automatically restored whenever features are added or eliminated upon a firmware update. (→ Firmware-Update)

Therefore, you should check your configuration status after each firmware update.

5.7 Data recording

Data may be recorded in two ways:

- Online mode

The N4000+ transmits received messages directly to a PC, where they are stored in log files. To do so, the N4000+ must be connected to the PC.

- HDD mode

Received messages are stored on the internal N4000+ storage medium, on a USB flash drive or on the XORAYA ESU. No PC is required in this case, as the N4000+ is fully autonomous in this mode. HDD logging may still be started and stopped from the PC.



Simultaneous recording modes

Both modes can be operated in parallel, but separately controlled.

5.7.1 Online mode

The *Online-Logging* tool enables data recording in online mode.

- ▶ Connect the N4000+ to the measurement environment.
(→ Connecting the N4000+ to the measuring environment)
- ▶ Connect the N4000+ to the PC. (→ Connecting the N4000+ to the PC)
- ▶ Turn on the N4000+.
- ▶ Start the *Online-Logging* tool of the XORAYASuite. (→ Starting)
- ▶ Connect to the desired N4000+. (→ Connecting the N4000+)

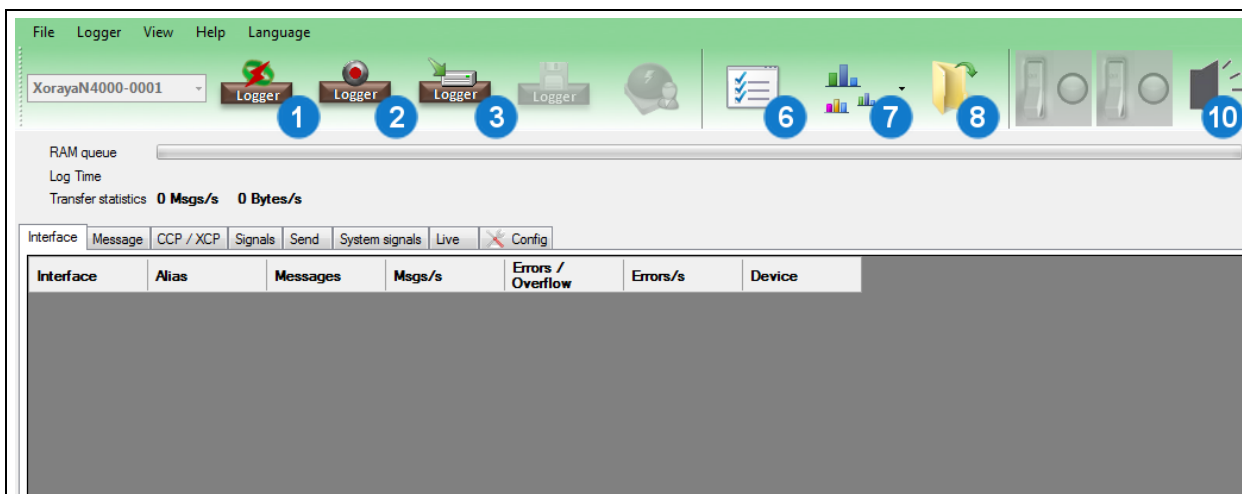

1	Release connection to logger	8	Open the latest created session or measurement in the <i>Viewer</i> tool
2	Start online logging		
3	Start Hdd logging	10	Trigger acoustic signal to identify N4000+
6	Display settings		
7	Displays the current bus traffic		

Use *Display settings* (6) to customise the following:

- Path and filename (→ Export settings)
- Output format (→ Output formats)
- Acoustic warning or executing a script if a bus error is detected
- Buses to be recorded
- Colour assignments for the interfaces
- Signal description (→ Signal description settings)
- Load configuration template (Busspec)
- Manage logger favourites (→ Favourites)

Store data on the PC:

- ▶ Click *Start online logging* (2).

Data received via interfaces are recorded on the PC.



HDD mode

Start the recording on the internal or external storage medium of the N4000+ via *Start Hdd logging* (3) or autonomously without a PC, as described in the relevant section. (→ HDD mode)

Both modes can be operated simultaneously.

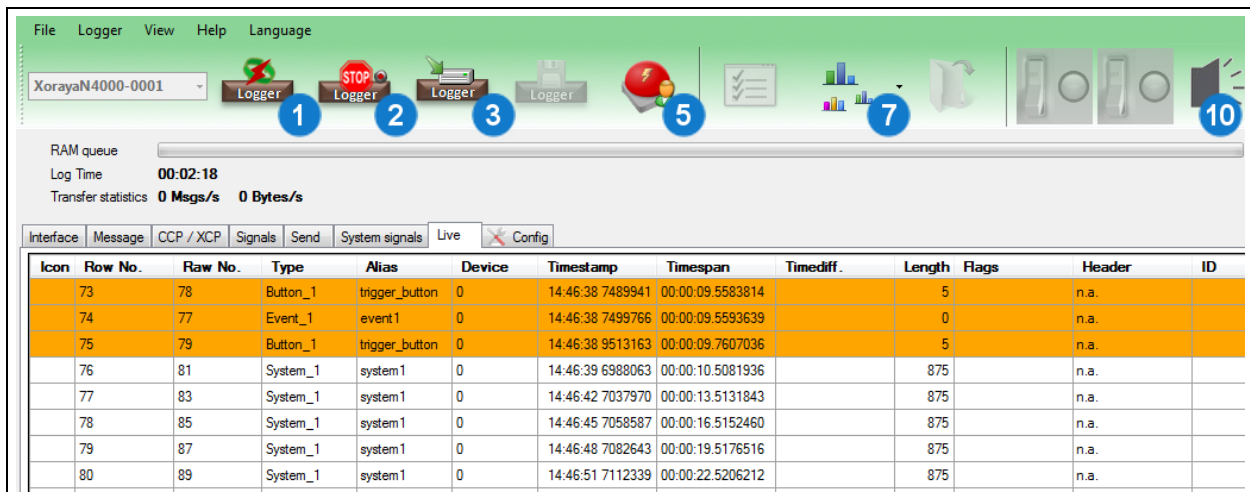

Icon	Row No.	Raw No.	Type	Alias	Device	Timestamp	Timespan	Timediff.	Length	Flags	Header	ID
	73	78	Button_1	trigger_button	0	14:46:38 7489941	00:00:09.5583814		5		n.a.	
	74	77	Event_1	event1	0	14:46:38 7499766	00:00:09.5593639		0		n.a.	
	75	79	Button_1	trigger_button	0	14:46:38 9513163	00:00:09.7607036		5		n.a.	
	76	81	System_1	system1	0	14:46:39 6988063	00:00:10.5081936		875		n.a.	
	77	83	System_1	system1	0	14:46:42 7037970	00:00:13.5131843		875		n.a.	
	78	85	System_1	system1	0	14:46:45 7058587	00:00:16.5152460		875		n.a.	
	79	87	System_1	system1	0	14:46:48 7082643	00:00:19.5176516		875		n.a.	
	80	89	System_1	system1	0	14:46:51 7112339	00:00:22.5206212		875		n.a.	

1	Release connection to logger	7	Displays the current bus traffic
2	Stop online logging	10	Trigger acoustic signal to identify N4000+
3	Start Hdd logging		
5	Set Trigger for later evaluation		

Online logging information is distributed over several tabs.

The following table describes the general function of each tab and the options offered in the context menu when right-clicking.

Tab	Function and context menu
Interface	Summary of recorded messages and errors grouped by interfaces and channels Context menu: <ul style="list-style-type: none"> Show or hide columns Hide inactive interfaces or channels
Message	Summary of recorded messages and errors grouped by messages Context menu: <ul style="list-style-type: none"> Fix selected rows Filter data by interfaces or channels Legend of the error flags
CCP / XCP	Summary of recorded CCP / XCP signals Context menu: <ul style="list-style-type: none"> Fix selected rows Hide selected messages Accelerate ECU registration of signals Represent data graphically (→ Graph View) Display physical properties
Signals	Monitoring of defined signals (→ Signal selection) Context menu: <ul style="list-style-type: none"> Show or hide columns Hide selected signals Save, load and delete signal lists
Send	Send user-defined CAN, RS-232 or Ethernet UDP messages once or cyclically
System signals	Display of system signals (core temperature, for example) as widgets
Live	Live view of the current recording, where a row corresponds to a message Context menu: <ul style="list-style-type: none"> Show or hide columns Filter data by interfaces, channels or CAN/FlexRay IDs Set Timemaster Freeze display Free up display area: Delete displayed rows Set the number of rows displayed (default: 500) Set details of the selected row: Specify whether the detail view will jump to new incoming messages or remains constant Represent data graphically (→ Graph View)
Config	Current N4000+ configuration



Messages and signals

The payload of a message consists of signals with variable bit length.

Messages and signals are assigned names for easier handling.



Timemaster

An additional column *Timediff.* is displayed when you set the Timemasters on a particular record. This column contains the time difference of each record to the Timemaster.

Represent data in graphical form:

- ▶ Click *Displays the current bus traffic (7)*.
- ▶ Choose among *Bus statistics*, *Message statistics* and *Interface statistics* the desired source data for graphical output. (→ Graph View)

Stop data recording:

- ▶ Click *Stop online logging (2)*.

5.7.2 HDD mode

In this mode, the N4000+ saves to one of the following media:

- Internal storage medium (default)
- USB flash drive if *Record on USB stick* in the *Hard Disk* category is checked and the conditions described there are met (→ Hard Disk)
- Additional device XORAYA ESU (automatically if detected by the N4000+)

Start data recording:

- ▶ Connect the N4000+ to the measurement environment.
(→ Connecting the N4000+ to the measuring environment)
- ▶ Optionally:
Connect a USB flash drive to the USB host interface (C).
(→ Connections and controls)
- ▶ Optionally:
Connect a XORAYA ESU to the corresponding interface (F).
- ▶ Turn on the N4000+.
- ▶ Start the HDD recording by pressing the trigger button (K) on the N4000+.

Data received via the interfaces are recorded.

Stop data recording:

- ▶ Press the trigger button (K) for at least 3 seconds.



Configuration of trigger button

The behaviour of the trigger button can be configured via the button interface. (→ Button)



HDD mode in the XORAYASuite

You can also start and stop the HDD mode from the *Configuration*, *Online-Logging*, *Hdd-Download* and *Firmware-Update* tools.

Data recorded on the storage medium is stored as sessions. Sessions always contain complete messages and are limited to a maximum size which defaults to 1000 MB.

New sessions are created under the following conditions:

- The HDD recording is started manually by a trigger or via the XORAYASuite.
- The N4000+ is turned on or woken up and *Autostart* in the *Hard Disk* category is checked. (→ Hard Disk)
- The session size exceeds the maximum size specified. In this case, the current session is closed, and a new session for the current measurement starts.

Sessions are closed under the following conditions:

- Recording is stopped manually
- The N4000+ goes into sleep mode
- The maximum size is exceeded

Existing sessions and measurements on the storage medium can be displayed, downloaded or deleted in the *Hdd-Download* tool of the XORAYASuite. (→ Hdd-Download)

5.7.3 Log data

The storage location for log data to be recorded is specified in the text boxes *Path* and *Filename*. This applies both to the online logging as well as to log data downloaded from the storage medium.

Log data in *X2E-Native* format are stored in various files with the same base name but different file extensions. (→ X2E-Nativ)

The master file with the file extension DLI serves as link. This file contains information about the included log interfaces and references to the corresponding binary files.

File	Format	Meaning
<name>.dli	ASCII	Master file: <ul style="list-style-type: none"> Contains information about log interfaces and references to the binary files
<name>.dlm	Binary	Meta file: <ul style="list-style-type: none"> Contains index information for faster search within binary data
<name>_0000.dlf <name>_0001.dlf ...	Binary	Binary file: <ul style="list-style-type: none"> Contains recorded data for all log interfaces To limit the file size, data are spread across multiple sequentially numbered files as needed
<name>.dls	ASCII	Statistics file: <ul style="list-style-type: none"> optionally created if the property <i>WriteStatistics</i> is checked

5.8 Hdd-Download

This tool allows downloading log data stored on the datalogger storage medium or a USB flash drive.

- ▶ Connect the N4000+ to the PC. (→ Connecting the N4000+ to the PC)
- ▶ Optionally:
Connect a XORAYA ESU to the corresponding interface (F).
(→ Connections and controls)
- ▶ Turn on the N4000+.
- ▶ Start the *Hdd-Download* tool of the XORAYASuite. (→ Starting)

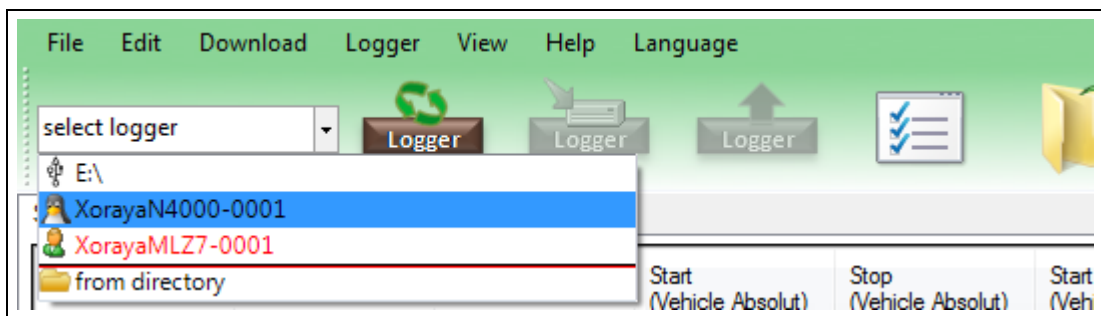

- ▶ Connect to the desired N4000+. (→ Connecting the N4000+)
- or*
- ▶ Connect to a USB flash drive that contains recorded measurements.
- or*
- ▶ Connect to a directory on your PC that contains a measurement recorded via USB.



USB flash drive in list

The connected USB flash drive is only available in the list if it is named *XORAYALOG* and contains the folder *usb_queue*.

The following descriptions refer to the connection with a N4000+. Connecting with a USB flash drive or a directory works principally in the same way.

1	Release connection to logger	5	Display settings
2	Start Hdd logging	6	Open last used path in Windows Explorer
3	Start download	7	Show download statistics
4	Change disk*		

* Only with connected XORAYA ESU

Click *Change disk* (4) to change between the internal storage medium and a connected XORAYA ESU.

Use *Display settings* (5) or the *Settings* command in the *Download* menu to customise the following:

- Miscellaneous settings, for example, enable/disable time groups or eject the USB flash drive automatically after disconnecting
- Colour assignments for the interfaces
- Manage logger favourites (→ Favourites)



Change temporary download folder

When downloading measurements that include a stream queue part, by default, the XORAYASuite saves data in the Windows temporary folder. If there is not sufficient disk space available on this drive, it is possible to specify an alternative path in the user or system environment variable `X2E_XORAYA_SHADOW_DIR`.

Please note that restarting Windows might be necessary after setting the environment variable. For further questions, contact your system administrator.

There are different ways to select the log data to download:

- *Edit menu: Select all or Select none*
- *Sessions and Measurements tabs*
- *Calendar tab*
- *Time range tab*

Sessions/Measurements:

You can show and hide the *Sessions* tab in the settings.

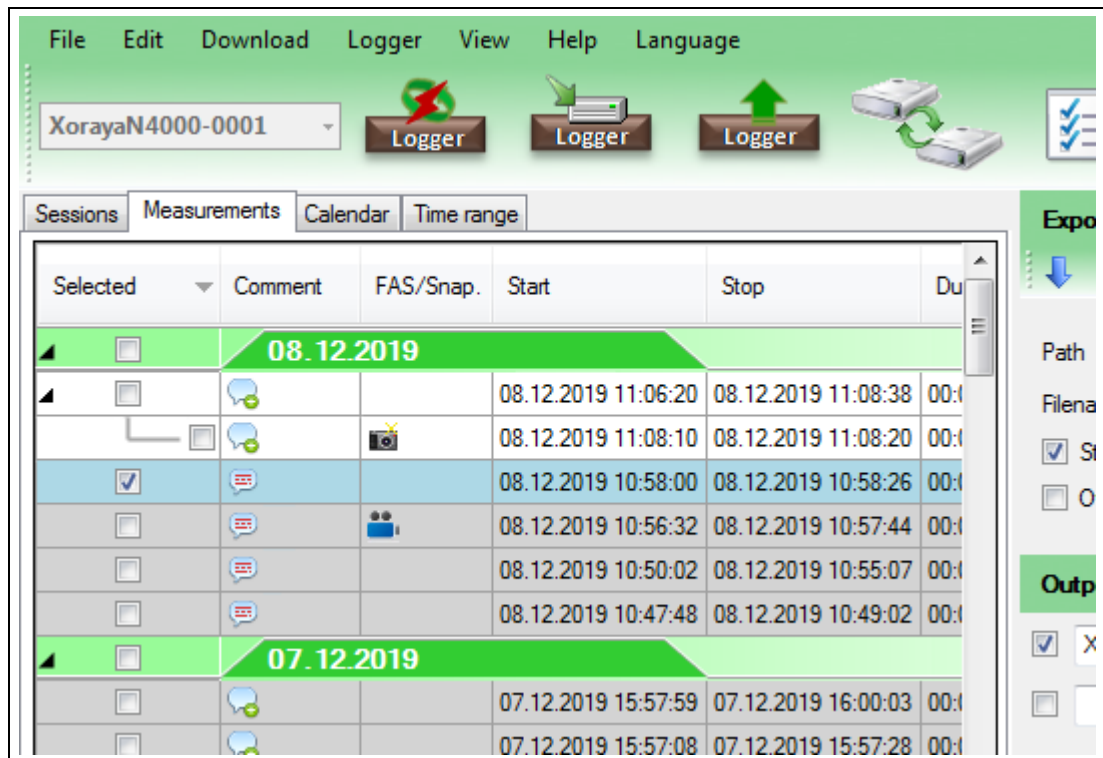

- ▶ Select the check boxes in the *Selected* column.

or

- ▶ Right-click to access the advanced selection options in the context menu.

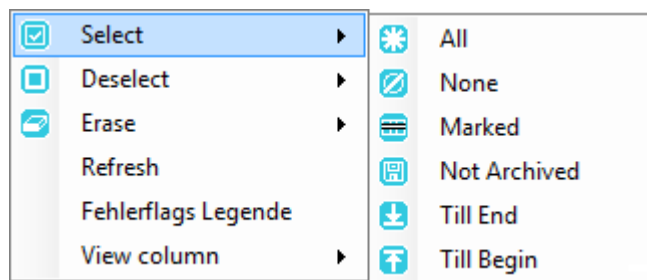

Calendar:

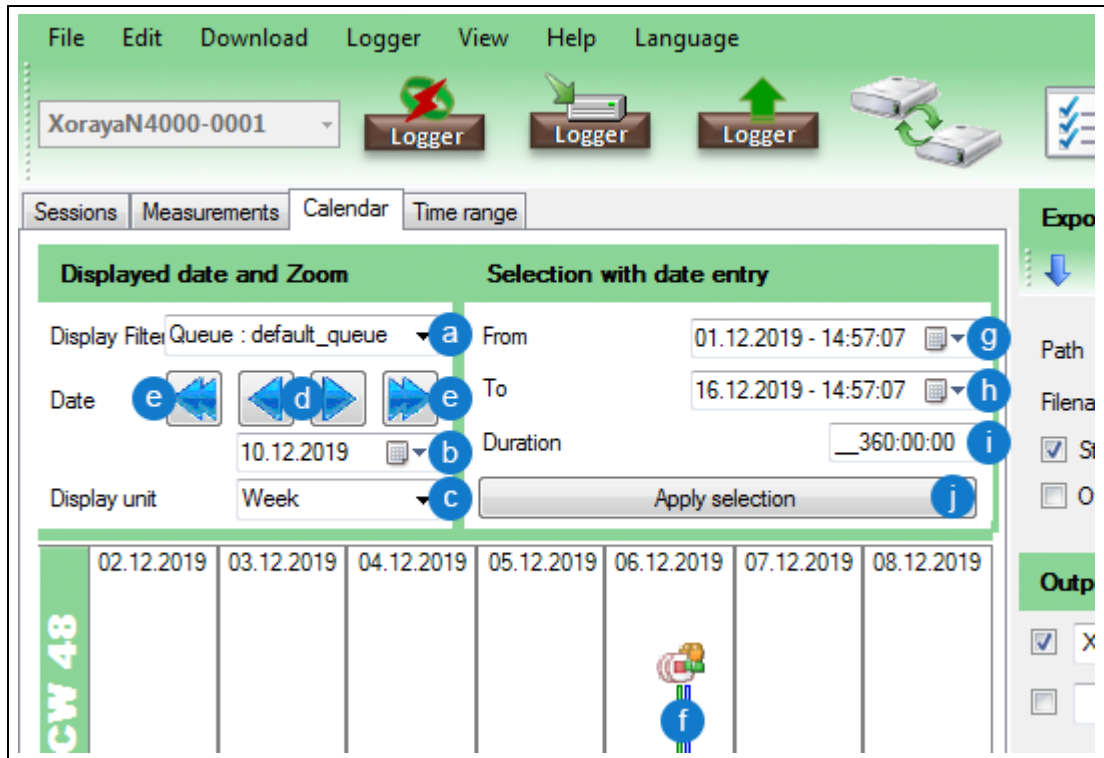

Displayed date and Zoom:

- ▶ Filter the displayed measurements, for example, by default or streaming queue **(a)**.
 - ▶ Specify a start date **(b)**.
 - ▶ Choose between *Week* and *Day* **(c)** as the displayed time unit.
 - ▶ Click the single arrows **(d)** to jump one day or one week forward or backward.
 - ▶ Click the double arrows **(e)** to jump three days or three weeks forward or backward.
 - ▶ Click the graphical representation of a measurement **(f)** to select it.
- or*
- ▶ Click and drag to select all measurements in this time range.

Select with date entry:

- ▶ Specify start date and start time **(g)**.
 - ▶ Specify end date and end time **(h)**.
- or*
- ▶ Enter the duration **(i)**.
 - ▶ Click *Apply selection* **(j)**.

Time range:

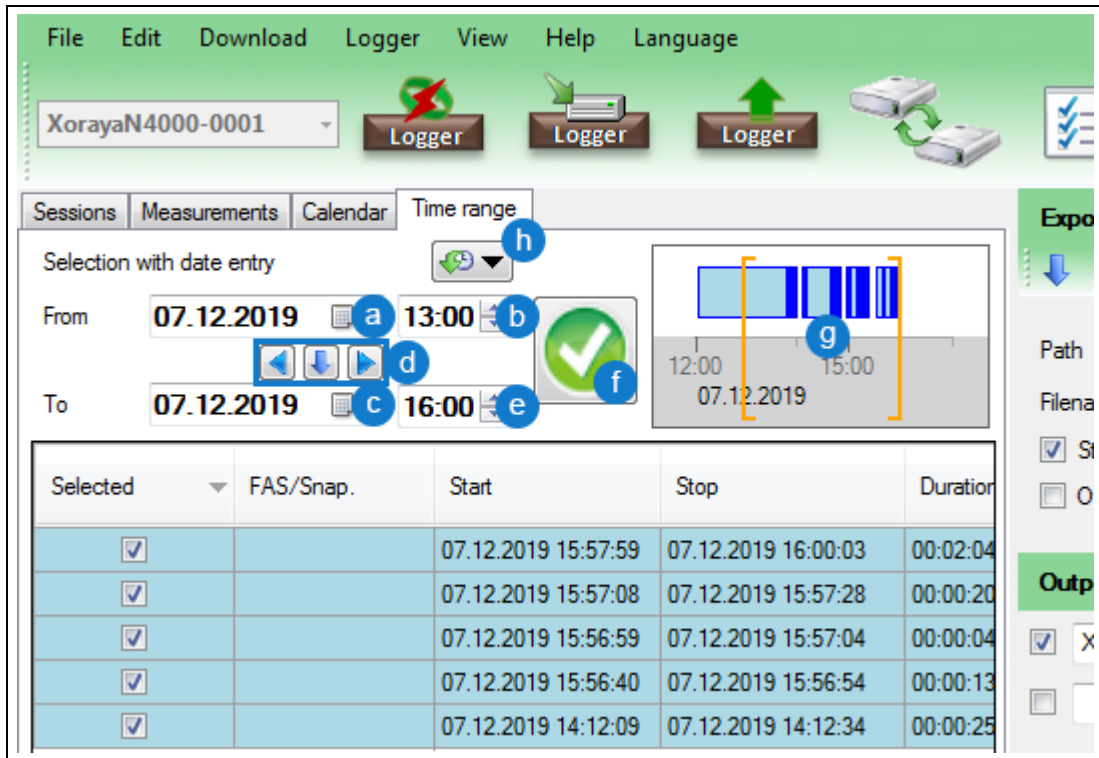

Selected	FAS/Snap.	Start	Stop	Duration
<input checked="" type="checkbox"/>		07.12.2019 15:57:59	07.12.2019 16:00:03	00:02:04
<input checked="" type="checkbox"/>		07.12.2019 15:57:08	07.12.2019 15:57:28	00:00:20
<input checked="" type="checkbox"/>		07.12.2019 15:56:59	07.12.2019 15:57:04	00:00:04
<input checked="" type="checkbox"/>		07.12.2019 15:56:40	07.12.2019 15:56:54	00:00:13
<input checked="" type="checkbox"/>		07.12.2019 14:12:09	07.12.2019 14:12:34	00:00:25

- ▶ Specify start date (a) and start time (b) of the desired time range.
- ▶ Specify the end date (c). Use the arrows (d) optionally to apply the start date or to jump one day forward or backward.
- ▶ Specify the end time (e).
- ▶ Click *Apply* (f).
- ▶ Limit the time range further by clicking and dragging inside the graphical representation (g).



History

The time ranges defined since starting the tool can be selected again via the *History* button (h).

Settings:

- ▶ Specify the *Export settings*. (→ Export settings)
- ▶ Specify the *Output formats*. (→ Output formats selection)



Load settings from N4000+

If you have previously used the *Export* category to save client settings on the N4000+, then you can load these via this button. (→ Export)

Additionally, you are asked if you want to apply the settings when connecting to the N4000+.

Download log data:

- ▶ Click *Start download (3)*.
- or*
- ▶ In the *Download* menu, click *Start*.

The selected sessions or measurements are transmitted to the PC.

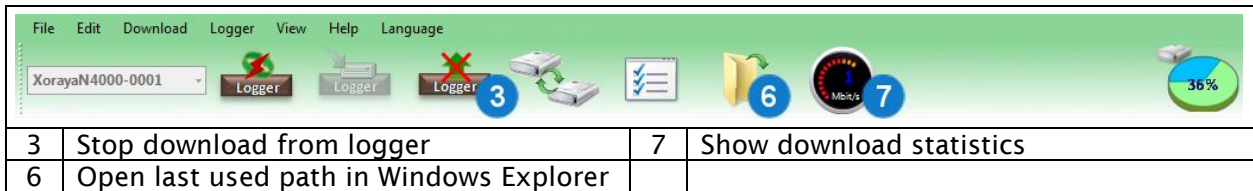

Statistical data

Click the arrow behind *Show download statistics (7)* to switch between different statistics.

The symbol displays the current value during download and the average as the process completes.

Click *Show download statistics (7)* to show statistical data graphically. (→ Graph View)

Cancel download:

- ▶ Click *Stop download from logger (3)*.
- or*
- ▶ In the *Download* menu, click *Cancel*.

5.9 Viewer

This tool allows display and analysis of records. No N4000+ connection is necessary to do this.

- ▶ Start the *Viewer* tool of the XORAYASuite. (→ Starting)

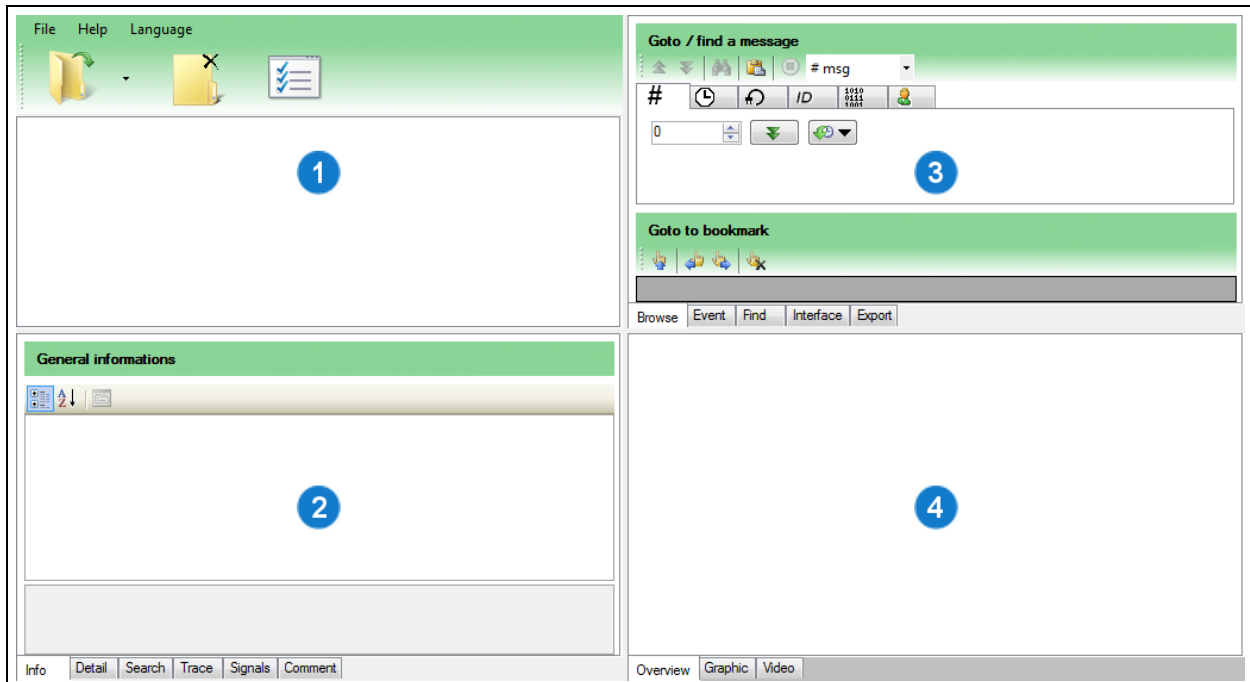

The subsequent view is divided into four panels, which can be resized at will:

- Data (1)
- Information (2)
- Search, filter and export (3)
- Graphical output (4)

5.9.1 Data

This panel displays the record set of the opened measurement.

Icon	Row No.	Raw No.	Type	Alias	Device	Timestamp	Times
	75	75	Button_1	trigger_button	0	14:46:38 7489941	00:00:0
!	76	76	Event_1	event1	0	14:46:38 7499766	00:00:0
	77	77	Button_1	trigger_button	0	14:46:38 9513163	00:00:0
	78	78	System_1	system 1	0	14:46:39 6988063	00:00:1
	79	79	System_1	system 1	0	14:46:42 7037970	00:00:1
	80	80	System_1	system 1	0	14:46:45 7058587	00:00:1
	81	81	System_1	system 1	0	14:46:48 7082643	00:00:1
	02	02	System_1	system 1	0	14:46:51 7112220	00:00:2

1	Open measurement	3	Display settings
2	Close selected measurement	4	Opened measurements

Open measurement:

- ▶ Click *Open measurement* (1) and select the DLI file.
or
- ▶ In the *File* menu, click *Open* and select the DLI file.
or
- ▶ Drag-and-drop the DLI file from the Windows Explorer into the *Data* panel.

Display recently opened measurements:

- ▶ Click the arrow behind *Open measurement* (1).
or
- ▶ In the *File* menu, click *Recent files*.



Opened measurements and filter

Each open measurement is represented by a tab (4).

A filter icon in the respective tab identifies a configured interface filter. (→ Interface)

To delete the filter, right-click the desired tab and select *Cancel filter*.

Close measurement:

- ▶ Click *Close selected measurement (2)*.
or
- ▶ In the *File* menu, click *Close*.
or
- ▶ Right click the desired measurement tab and then on *Close the file*.

Right-click the desired record to view further options in the context menu:

- Set timemaster
- Set custom region
 - by manually selecting the start and stop row
 - automatically a certain time span before and after the selected row
- Add record to bookmarks
- Set time format (with date, 100 nanoseconds or standard)
- Show or hide columns
- Draw record signal in the *Graphic* tab of the *Graphical output* panel (→ Graphic)



Timemaster

An additional column *Timediff*. is displayed when you set the timemaster on a particular record. This column contains the time difference of each record to the Timemaster.



Custom region

Use a custom region to restrict your export scope. To do so, select the appropriate option in the source region selection. (→ Export)

In addition, the start and stop rows will be automatically added to the bookmarks.



Bookmarks

Adding records to the bookmarks allows jumping to a favourite record position immediately. (→ Browse)



On the right edge of the panel, there are two scroll bars that can be adjusted independently.

Left-click (1) to specify whether scrolling is by row numbers or time.

Right-click (1) to specify how many rows or how much time is scrolled per click on the double-arrow buttons (2).

Left-click the single-arrow buttons (3) to move only one row at a time.



Fine zone

If a Fine zone is specified in the *Overview* tab of the *Graphical output*, the left scroll bar refers to this zone. (→ Overview)

5.9.2 Information

This panel displays information about active measurement and search results.

Tabs:

- Info
- Detail
- Search
- Trace
- Signals
- Comment

Info:

This tab displays general information about all records for the open measurement.

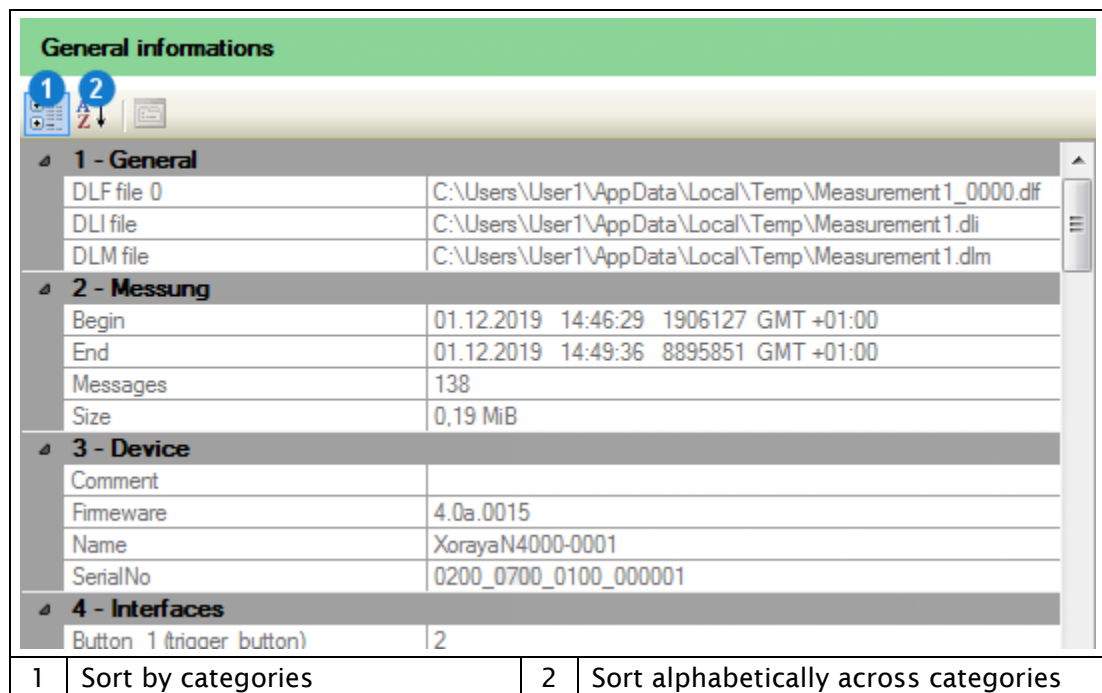

General informations	
1 - General	
DLF file 0	C:\Users\User1\AppData\Local\Temp\Measurement1_0000.dlf
DLI file	C:\Users\User1\AppData\Local\Temp\Measurement1.dli
DLM file	C:\Users\User1\AppData\Local\Temp\Measurement1.dlm
2 - Messung	
Begin	01.12.2019 14:46:29 1906127 GMT +01:00
End	01.12.2019 14:49:36 8895851 GMT +01:00
Messages	138
Size	0,19 MiB
3 - Device	
Comment	
Firmware	4.0a.0015
Name	XorayaN4000-0001
SerialNo	0200_0700_0100_000001
4 - Interfaces	
Button 1 (trigger button)	2

1 Sort by categories	2 Sort alphabetically across categories
------------------------	---

Detail:

This tab displays detailed information about the currently selected record. The display changes depending on the interface type.

Detail # 0 System_2 18.12.2019 09:59:40 6164661 GMT +01:00

System

1 Data
SYS_INFO
Version 2
1 of 1
Application GXHddGet
SKD_Version 2.5.0.16
SDK_BuildDate "Nov 18 2019" "00:41:51"
RawMsgProcessing 1.0

Flags

Raw Length: 129 Global Flags: 0x0
Timestamp: 0x3803A2A657F6B5 Interface: 0x2000211

2 Raw Data

0000	53 59 53 5F 49 4E 46 4F	SYS_INFO
0008	0A 56 65 72 73 69 6F 6E	.Version
0016	20 32 0A 31 20 6F 66 20	2.1 of
0024	31 0A 41 70 70 6C 69 63	1.Applic
0032	61 74 69 6F 6E 20 47 58	ation GX
0040	48 64 64 47 65 74 0A 53	HddGet.S

1	Data	3	Data values
2	Raw data	4	Raw data values

Right-click anywhere on the white or green background part of the user interface to select whether the underlying raw data (2) is also displayed alongside the data (1).

Right-click anywhere on the data values (3) or raw data values (4) to change the display between:

- Hexadecimal (base 16)
- Decimal (base 10)
- Octal (base 8)
- Binary (base 2)
- ASCII
- Automatically selected display

Search:

This tab displays records found by search processes using the button *All since cursor*.

The button *All since cursor* can be found in the following panels and tabs:

- *Information panel, Signals tab*
- *Search, filter and export panel, Browse tab*
- *Search, filter and export panel, Find tab*

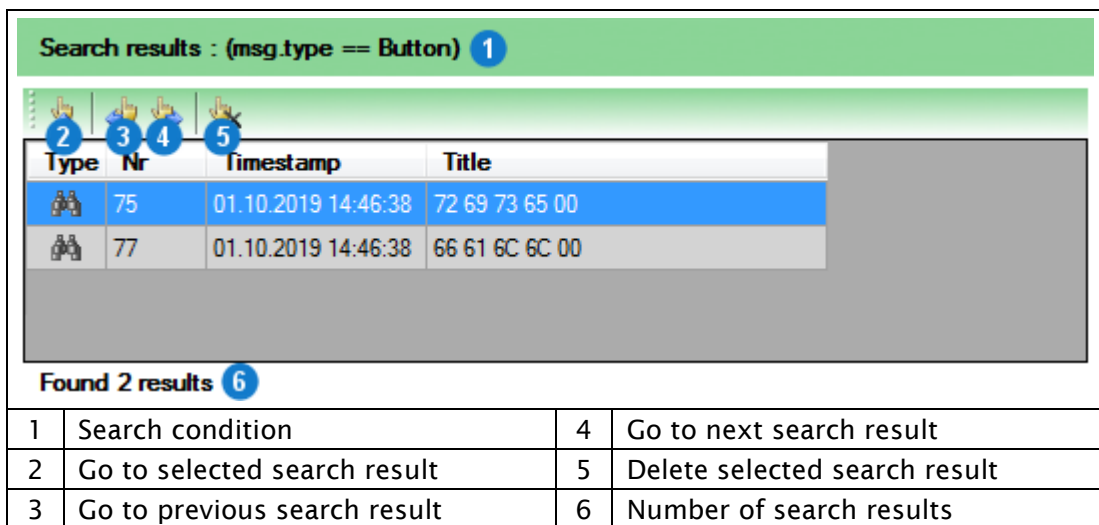

Type	Nr	Timestamp	Title
	75	01.10.2019 14:46:38	72 69 73 65 00
	77	01.10.2019 14:46:38	66 61 6C 6C 00

1	Search condition	4	Go to next search result
2	Go to selected search result	5	Delete selected search result
3	Go to previous search result	6	Number of search results

Trace:

This tab displays status and error messages.

Signals:

Use this tab to search for specific signals in the records of the opened measurement. The right-side view is different depending on whether *Show signal details (13)* or *Manage signal lists (12)* is activated.

Show signal details (13) is activated:

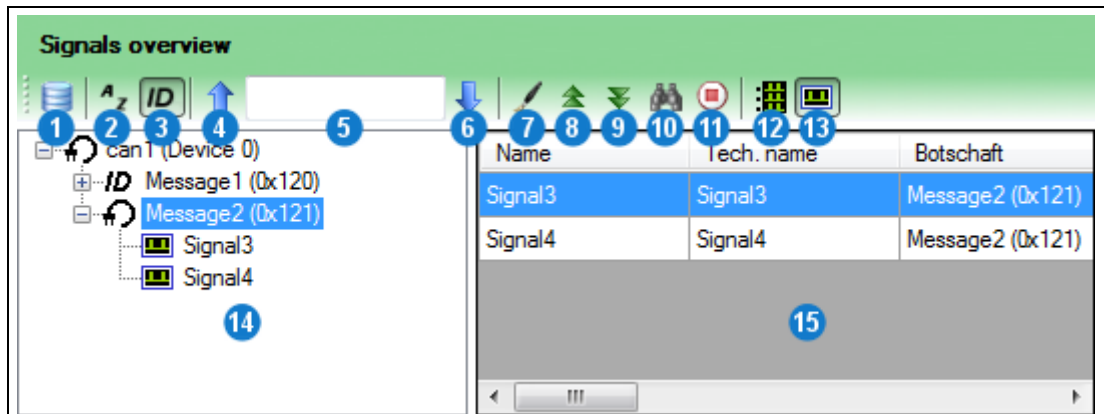

1	Signal description settings	9	Next
2	Sort alphabetically	10	All since cursor
3	Sort by ID	11	Cancel
4	Find previous	12	Manage signal lists
5	Search box	13	Show signal details
6	Find next	14	Signals overview
7	Draw selected signals	15	Signal details
8	Previous		

Add signals to signals overview (14):

- ▶ Click *Signal description settings (1)*.
- ▶ Add one or more description files to the current signal group.
(→ Signal description settings)

Sort the signals overview (14):

- ▶ Click *Sort alphabetically (2)* to sort by message name.
or
- ▶ Click *Sort by ID (3)* to sort by message ID.

Search by message, signal or ID in the signals overview (14):

- ▶ Enter the term or partial term in the search box (5).
- ▶ Click *Find previous (4)*.
or
- ▶ Click *Find next (6)*.

Display signal details (15):

- ▶ Select a message in the signals overview (14) to view details for all signals of this message.

or

- ▶ Select a signal to view details for this signal.

Display signals graphically:

- ▶ Select a signal in the signal details (15).

or

- ▶ Select multiple signals by using the Shift key or the Ctrl key.
- ▶ Click *Draw selected signals* (7) to display the graphical representation in the *Graphic* tab. (→ Graphic)

Search message in open log data:

- ▶ In the signals overview (14), select the message to be searched for.
- ▶ Click *Previous* (8) to move to the previous record of this message.

or

- ▶ Click *Next* (9) to move to the next record of this message.

or

- ▶ Click *All since cursor* (10) to display all records of this message, starting at the current position, in a list. (→ Search)

Cancel search:

- ▶ Click *Cancel* (11).

Manage signal lists (12) is activated:

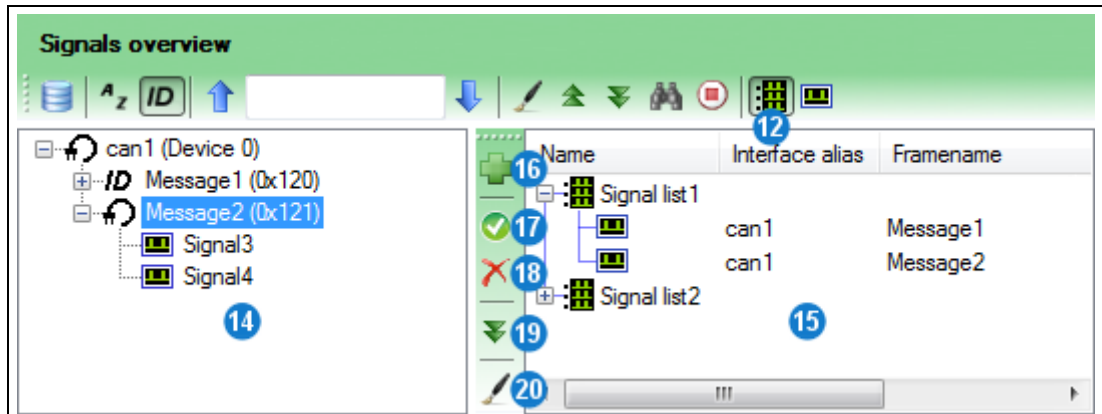

12	Manage signal lists	17	Add signal to list
14	Signals overview	18	Delete signal from list
15	Signal lists	19	Find signal
16	Add new signal list	20	Draw signal

Create new signal list:

- ▶ Click *Add new signal list* (16).

Add signal to signal list:

- ▶ Select the signal list (15).
- ▶ Select the signal in the signals overview (14).
- ▶ Click *Add signal to list* (17).

Delete signal from signal list:

- ▶ Select the signal in the signal list (15).
- ▶ Click *Delete signal from list* (18).

Delete signal list:

- ▶ Select the signal list (15).
- ▶ Click *Delete signal from list* (18).

Display signal from signal list (15) in the signals overview (14):

- ▶ Select the signal in the signal list (15).
- ▶ Click *Find signal* (19).

5.9.3 Search, filter and export

Use this panel to search the open measurement according to different criteria, filter records and export them to other output formats.

Tabs:

- Browse
- Event
- Find
- Interface
- Export

Browse:

Use this tab to specify search criteria to move to the corresponding records in the *Data* panel. In addition, you can manage the bookmarks list.

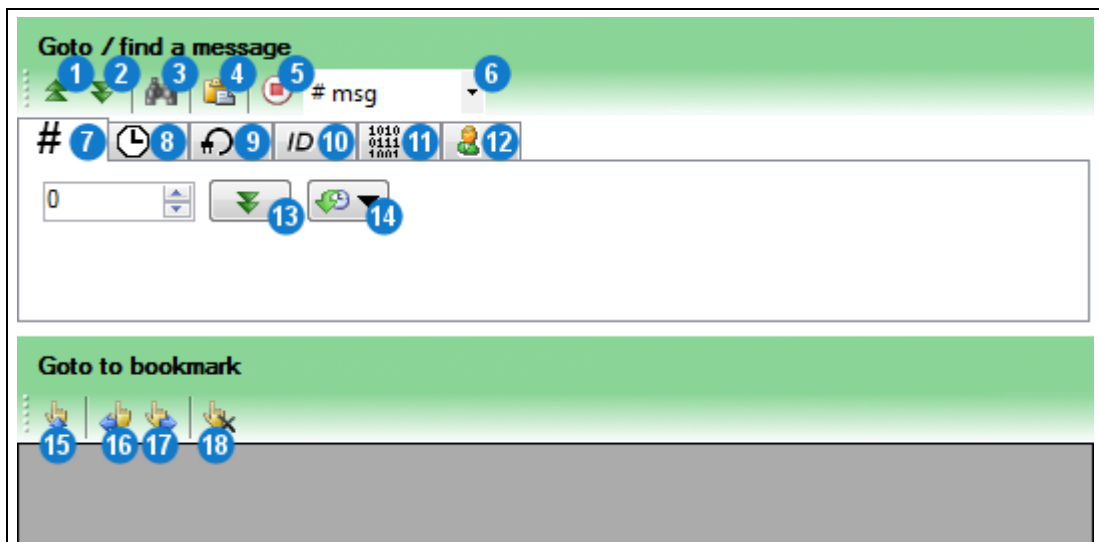

1	Previous	11	Search message by payload
2	Next	12	Search message by Interface, ID and payload
3	All since cursor		
4	Paste current selection value	13	Go to message
5	Cancel	14	History
6	Search criterion	15	Go to selected bookmark
7	Search message by number	16	Go to previous bookmark
8	Search message by date and time	17	Go to next bookmark
9	Search message by interface	18	Delete selected bookmark
10	Search message by ID		

Depending on the search criteria, the search condition is either unique or not.

You will find one record at the most when searching by:

- Message number **(7)**
- Date and time **(8)**

In certain circumstances, you may find multiple records in the search for:

- Messages of certain interfaces **(9)**
- Message IDs **(10)**
- Message payloads **(11)**
- Combination of the previous three **(12)**

To go to the (next) record that meets the desired search condition:

- ▶ Select search criteria from the tabs **(7)** to **(12)**.
or
- ▶ Select the corresponding criterion from the drop-down list **(6)**.
- ▶ Specify the search condition.
or
- ▶ Click *Paste current selection value* **(4)** to apply the value of the currently selected record.
- ▶ Click *Go to message* **(13)**.

Navigate between records:

- ▶ Click *Previous* **(1)** to go to the previous record found.
or
- ▶ Click *Next* **(2)** to go to the next record found.
or
- ▶ Click *All since cursor* **(3)** to display all records of this message, starting at the current position, in a list. (→ Search)

Cancel search:

- ▶ Click *Cancel* **(5)**.



History

Click *History* (14) to access the latest search conditions. This list is reset every time you exit the tool.



Bookmarks

To add a record to the bookmarks, right-click it in the *Data* panel and select the appropriate option.

Use the *Browse* tab to navigate between bookmarks or to delete them.

Event

This tab displays all events generated by the user or by the N4000+ itself. For example, events are triggered and stored by pressing the trigger button (K). (→ Connections and controls)

Event overview

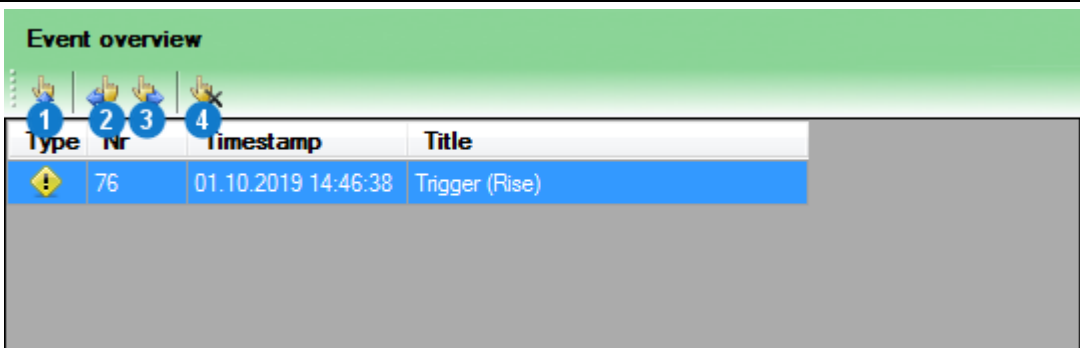

Type	Nr	Timestamp	Title
	76	01.10.2019 14:46:38	Trigger (Rise)

1	Go to selected event	3	Go to next event
2	Go to previous event	4	Delete selected event

Search:

User this tab to build complex searches.

1	Field	6	Next
2	Relation	7	All since cursor
3	Value	8	Previous
4	Add constraint	9	Cancel
5	Constraint expression		

- ▶ Select the *Field* (1) that you would like to add to your search.
- ▶ Select the *Relation* (2) between field and value.
- ▶ Specify the *Value* (3). Depending on the field, this is either presented as a text box or as a drop-down list with all available values.
- ▶ Click *Add constraint* (4).
 - The condition is added to the *Constraint expression* (5).
- ▶ Repeat the above steps to add further constraints to the constraint expression.

Navigate between records:

- ▶ Click *Previous* (8) to go to the previous record found.
or
- ▶ Click *Next* (6) to go to the next record found.
or
- ▶ Click *All since cursor* (7) to display all records of this message, starting at the current position, in a list. (→ Search)

Cancel search:

- ▶ Click *Cancel* (9).

Interface:

Use this tab to filter the displayed records in the *Data* panel.

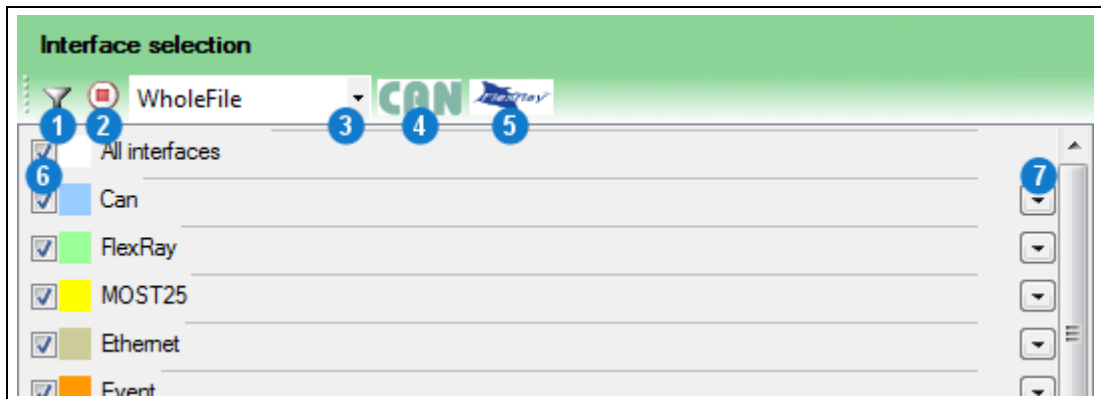

1	Start	5	Select FlexRay IDs
2	Cancel	6	Interfaces
3	Filter region	7	Interface channels
4	Select CAN IDs		

Filter options:

- Filter region (3)
 - WholeFile All records
 - FineZone Zone specified in the *Overview* tab of the *Graphical output* panel (→ Overview)
 - ScreenWide Records that are currently visible on the screen
- CAN IDs (4) and FlexRay IDs (5)
- Interfaces (6) and interface channels (7)

Apply filter:

- ▶ Add the desired filter.
- ▶ Click *Start* (1).
- Records in the *Data* panel are filtered.

Cancel filter:

- ▶ Click *Cancel* (2).

Export:

Use this tab to export the records to various output formats.

1	Export settings	3	Source region selection
2	Output formats selection	4	Start

Source region selection:

- Whole measurements All records
- Fine zone Zone specified in the *Overview* tab of the *Graphical output* panel (→ Overview)
- Custom region Region specified in the *Data* panel (→ Data)
- Selection Selected records
- Pre-/post-triggers (sec.) Period before and after raised triggers



Pre-/post-triggers

If this option is selected, you can double-click to change the time period before and after a trigger is raised.

Default values are configured in the *Hdd-Download* tool settings. (→ Hdd-Download)

Export records:

- ▶ Specify the export settings (1). (→ Export settings)
 - ▶ Select the output formats (2). (→ Output formats selection)
 - ▶ Select the source region (3).
 - ▶ Click *Start* (4).
- Selected records are exported.



Cancel export:

- ▶ Click *Cancel* (5).

5.9.4 Graphical output

This panel displays the open measurement graphically.

Tabs:

- Overview
- Graphic
- Video

Overview:

This tab displays the timeline of the opened measurement. Icons represent events, bookmarks and search results. You can also specify a Fine zone to filter the records to display and export.

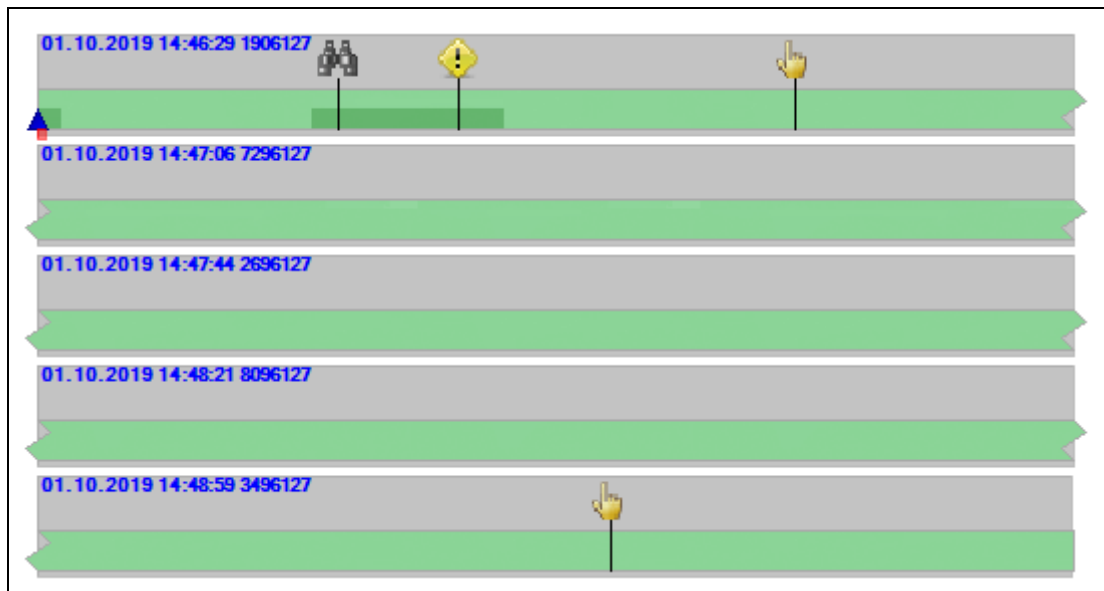

Set Fine zone:

- ▶ Click and drag over the area of the desired Fine zone.
 - ▶ Confirm your choice by clicking *<Set Fine Zone>*.
- The Fine zone is set.

Graphic:

This tab shows selected values of the open measurement as time curves.

Display data graphically:

- ▶ In the *Data* panel, right-click a record of the interface channel that you would like to see in graphical format. (→ Data)
- ▶ Point to *Draw signal*.
- ▶ Select the desired value.
 - The time curve of the value is displayed graphically. (→ Graph View)
- ▶ Repeat the above steps to add further values to the chart.

**Draw message signals**

Choose individual message signals in the *Signals* tab of the *Information* panel. (→ Signals)

5.10 Statistic

This tool allows the evaluation of statistical data during N4000+ operation, also simultaneous to data recording.

- ▶ Connect the N4000+ to the PC. (→ Connecting the N4000+ to the PC)
- ▶ Turn on the N4000+.
- ▶ Start the *Statistic* tool of the XORAYASuite. (→ Starting)
- ▶ Connect to the desired N4000+. (→ Connecting the N4000+)

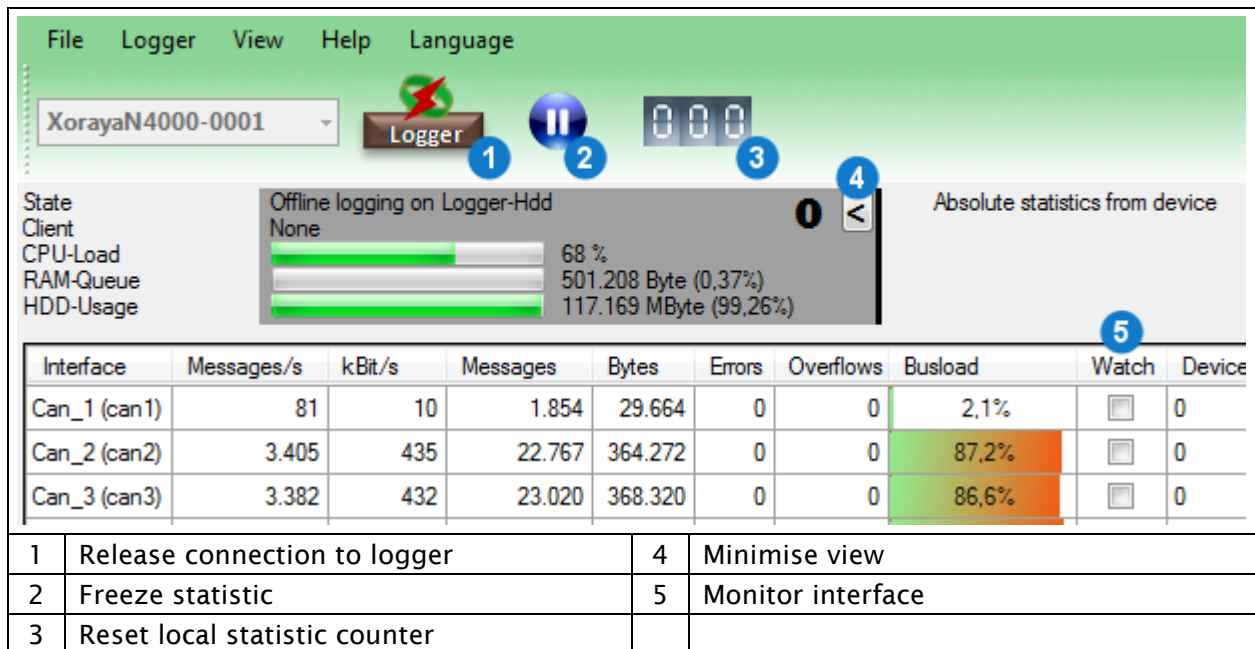

Interface	Messages/s	kBit/s	Messages	Bytes	Errors	Overflows	Busload	Watch	Device
Can_1 (can1)	81	10	1.854	29.664	0	0	2,1%	<input type="checkbox"/>	0
Can_2 (can2)	3.405	435	22.767	364.272	0	0	87,2%	<input checked="" type="checkbox"/>	0
Can_3 (can3)	3.382	432	23.020	368.320	0	0	86,6%	<input checked="" type="checkbox"/>	0

1	Release connection to logger	4	Minimise view
2	Freeze statistic	5	Monitor interface
3	Reset local statistic counter		

Monitor a specific interface individually:

- ▶ In the corresponding row, click the check box *Watch* (5).
 - The row is highlighted when messages are received.
 - The buttons in the toolbar change to reflect the current state of the statistic display:



Freeze statistic



Continue statistic



Display remote statistic counter

Statistic since the start of the tool and connection to the N4000+



Display local statistic counter

Statistic since last click on *Reset local statistic counter* (3)

5.11 Convert

This tool allows converting the log data recorded in the *X2E-Native* output format into various formats. (→ Output formats)

No N4000+ connection is necessary to do this.

- ▶ Start the *Convert* tool of the XORAYASuite. (→ Starting)

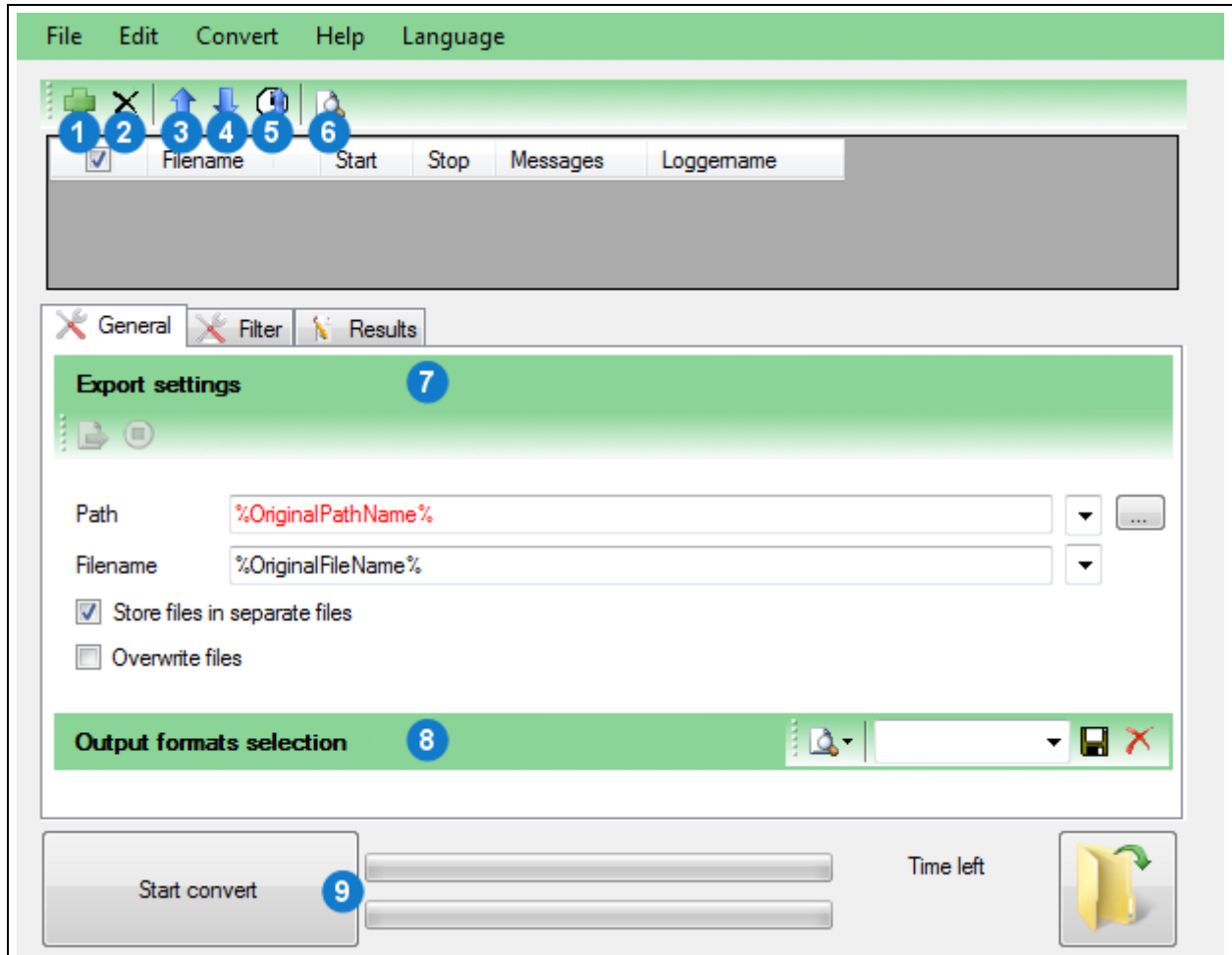

1	Add DLI file to list	6	Open selection in Viewer
2	Remove selected DLI files from list	7	Export settings
3	Move selection up	8	Output formats selection
4	Move selection down	9	Start convert
5	Auto sort by start time		

Add log files to the list:

- ▶ Click *Add DLI file to list* (1).
- ▶ Select the desired DLI file.
- ▶ Repeat as necessary for further log files.

Manually sort log files in the list:

- ▶ Select a row in the list.
- ▶ Click *Move selection up* (3).
- or*
- ▶ Click *Move selection down* (4).



Automatic sorting

Start and stop times of log files are displayed in red colour if shown out of chronological order in the list.

Click *Auto sort by start time* (5) to sort the log files in chronological order.

View log files in the *Viewer* tool:

- ▶ Select one or multiple rows in the list by using the Shift and Ctrl key.
- ▶ Click *Open selection in Viewer* (6).

Select or deselect log files in the list:

- ▶ Select the relevant check boxes.
- or*
- ▶ Select or clear the check box in the table header to select all log files or none.
- or*
- ▶ In the *Edit* menu, click *Select all* or *Select none*.

Delete log files from the list:

- ▶ Select the log files to be deleted.
- ▶ Click *Remove selected DLI files from list* (2).



Filter messages

If necessary, you can reduce the number of messages to be converted using the *Filter* tab.

Convert log files:

- ▶ Select the log files to be converted.
- ▶ Specify the export settings (7). (→ Export settings)
- ▶ Select the output formats (8). (→ Output formats selection)
- ▶ Click *Start convert* (9).

or

- ▶ In the *Convert* menu, click *Start*.

Recorded log files are converted.

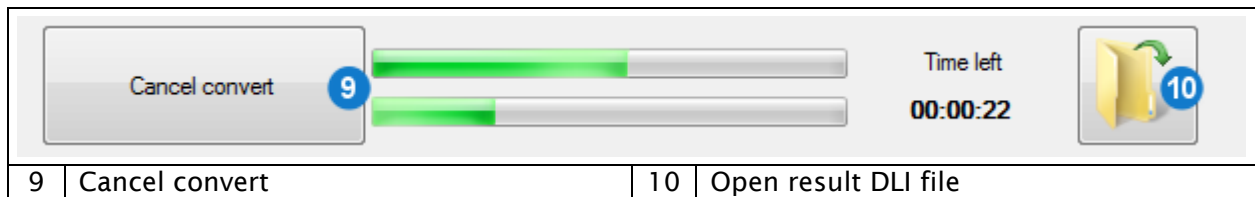

Cancel conversion:

- ▶ Click *Cancel convert* (9).
- or
- ▶ In the *Convert* menu, click *Cancel*.



Open converted files

After the successful conversion, click *Open result DLI file* (10) to open the path of the converted files in the Windows Explorer.

If you select the output format *X2E-Native*, you have the choice between opening the DLI files in the Explorer or directly in the *Viewer* tool for analysis purposes.

5.12 Firmware-Update

Use this tool to update the N4000+ firmware. The firmware update expands the N4000+ functionality and performs any required bug fixing.

- ▶ Connect the N4000+ to the PC. (→ Connecting the N4000+ to the PC)
- ▶ Turn on the N4000+.
- ▶ Start the *Firmware-Update* tool of the XORAYASuite. (→ Starting)
- ▶ Connect to the desired N4000+. (→ Connecting the N4000+)

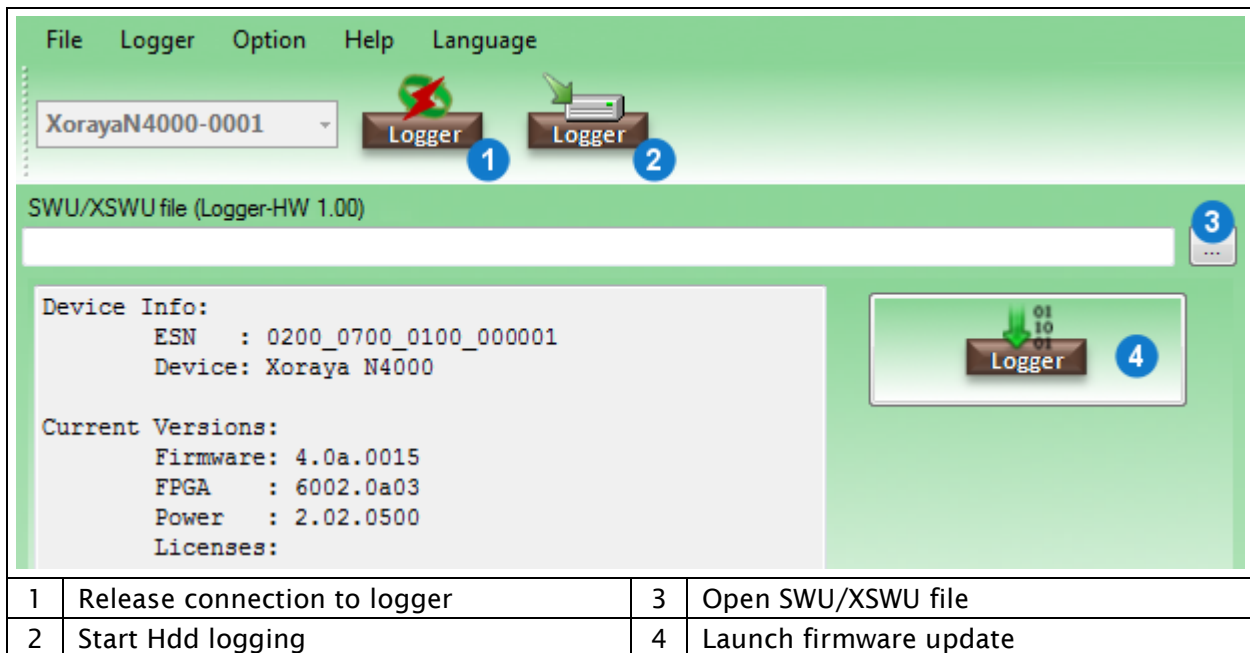

1	Release connection to logger	3	Open SWU/XSWU file
2	Start Hdd logging	4	Launch firmware update

Perform firmware update

- ▶ Download the latest firmware version from the X2E-Wiki. (→ X2E-Wiki)
- ▶ Click *Open SWU/XSWU file (3)*.

or

- ▶ In the *File* menu, click *Open SWU/XSWU file*.
- ▶ Select the firmware file.
- ▶ Make sure that the file corresponds to the N4000+.
- ▶ Click *Launch firmware update (4)*.

- The firmware is updated.



CAUTION

Do not interrupt the update process

Power supply interruptions can destroy the N4000+.

- ▶ Do not interrupt the N4000+ power supply while updating the firmware.

- ▶ Confirm the N4000+ restart twice, if *Ask before restart* in the *Option* menu is activated.
- ▶ Confirm the formatting of the N4000+ storage medium that may be necessary for compatibility reasons.

- If *Skip restoring the configuration* in the *Option* menu is not activated, the tool tries to restore the last N4000+ configuration.



Repeat the firmware update:

- ▶ If the update fails, click button (5) to reset the user interface to the initial state.



Activate licences

Activating and updating additionally acquired licences for the N4000+ works in the same way. Instead of the firmware file, select the provided licence file.



Firmware update via USB flash drive

Alternatively, you can also update the N4000+ firmware without the XORAYASuite. Connect a USB flash drive that contains the firmware archive in the *xoraya_update* folder to the USB host interface (C).
(→ Connections and controls)

The N4000+ automatically updates the firmware and disconnects the USB flash drive afterwards.

5.13 TK Commandline

This tool provides access to the XORAYAToolkit, a collection of commands optimised for script-oriented application.

- ▶ Connect the N4000+ to the PC. (→ Connecting the N4000+ to the PC)
 - ▶ Turn on the N4000+.
 - ▶ Start the *TK Commandline* tool of the XORAYASuite. (→ Starting)
- You can access the XORAYAToolkit via TK Commandline.

```
Setting environment for using Xoraya-Cmdline tools
-----
XHelp      - Display list of available commands
XScan     - Search for Loggers in network
XLogfile  - Do online logging
XConvFile - Convert/Filter data files
XJoinFile - Join data files
XFileInfo - Display info about log file
XCmpFile  - Compare data between 2 interfaces
XHddDir   - Show contents of Logger hdd (sessions)
XHddGet   - Download Logger hdd (sessions)
XHddErase - Delete Logger hdd (sessions)
XHddLog   - Start/Stop offline logging on Logger hdd
XConfig   - Administrate Logger settings
XSend     - Send message(s) via Logger
XStat     - Show interface statistics of (used) Logger
XShutdown - Shutdown/Restart Logger
XFWUpdate - Update Logger firmware
XDateTime - Convert date/time formats
XHddDirM  - Show contents of Logger hdd (measurement)
XHddGetM  - Download Logger hdd (measurement)
XHddEraseM - Delete Logger hdd (measurement)
XLinuxation - Install Linux OS on Logger
XProfile  - Handle user profiles from Logger
use Option -? on each command to get help

C:\ProgramData\Microsoft\Windows\Start Menu\Programs\X2E\Xoraya_x32\Documenta
```

The following commands are available:

Tool	Function
XHelp	Displays the available commands
XScan	Scans the network for dataloggers
XLogFile	Starts data recording in online mode and writes log data in various output formats
XConvFile	Filters X2E-Native log files and converts them into different output formats
XJoinFile	Joins X2E-Native log files
XFileInfo	Displays information about X2E-Native log files
XCmpFile	Compares two X2E-Native log files
XHddDir	Displays the sessions on the N4000+ storage medium
XHddGet	Downloads sessions from N4000+ in various output formats
XHddErase	Deletes sessions from N4000+ or formats the storage medium
XHddLog	Starts/stops data recording in HDD mode or sets a snapshot
XConfig	Reads/overwrites the N4000+ configuration or compares two configurations
XSend	Sends CAN messages via the N4000+
XStat	Displays N4000+ statistics
XShutdown	Shuts down or restarts the N4000+
XFWUpdate	Performs a firmware update
XDateTime	Converts between different date and time formats or compares PC time with N4000+ time
XHddDirM	Displays the measurements on the N4000+ storage medium
XHddGetM	Downloads measurements from the N4000+ in various output formats
XHddEraseM	Deletes measurements from the N4000+ or formats the storage medium
XLinuxation	Performs a system recovery of the N4000+
XProfile	Manages the user profiles of the N4000+

5.14 Common elements

This section describes GUI elements used in different parts of the XORAYASuite albeit in substantially the same way.

This manual makes reference to subsections of this section as required.

5.14.1 Changing the numbering system

For numerical values in text boxes, you can switch the display between three numbering systems. Already entered values are converted accordingly if possible.



- ▶ Click the symbol of the numbering system **(1)**.

or

- ▶ Right-click in the text box **(2)** and select the numbering system.

Abbreviations stand for the following numbering systems:

- 0x hexadecimal (base 16)
- Dec decimal (base 10)
- Bin Binary (base 2)

5.14.2 Set bits

In certain interface configuration categories, you specify the bytes of messages:

- CAN Trigger
- LIN Trigger
- Ethernet Filter

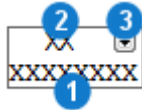

- ▶ Click an *X* in the bottom row of a byte (1) once or twice to set the desired bit to 0 or 1.
- ▶ Highlight an *X* in the top row of a byte (2) and enter one hexadecimal digit to specify the half-byte.
- ▶ Highlight *XX* in the top row of a byte (2) and enter two hexadecimal digits to specify the byte.
- ▶ If a byte is not fully defined, click the arrow (3) to display all possible values remaining for this byte.

5.14.3 Export settings

This control element can be found in the following tools: *Configuration*, *Online-Logging*, *Hdd-Download*, *Viewer* and *Convert*.

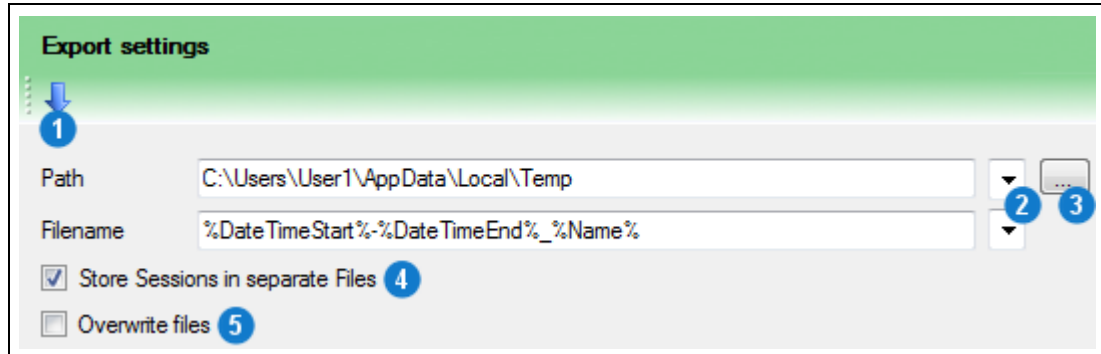

1	Download from N4000+*	4	Store sessions in separate files**
2	Attributes	5	Overwrite files
3	Browse for folder		

* Only in *Hdd-Download* ** Only in *Hdd-Download* and *Convert*

- ▶ Click *Browse for folder* (3) to select the *Path*.
(Path is not available in the *Configuration* tool, because the settings are saved on the N4000+ itself.)
- ▶ Enter the desired *Filename*.



Special attributes

You can automatically name the path and filename using special attributes. Select the desired attribute from the respective drop-down list (2).

Repeat the process to combine multiple attributes.

- ▶ Specify whether all selected sessions or DLI files are stored as separate files (4).
- ▶ Specify whether existing files with the same file name are overwritten (5).

5.14.4 Output formats selection

This control element can be found in the following tools: *Configuration*, *Hdd-Download*, *Viewer* and *Convert*.

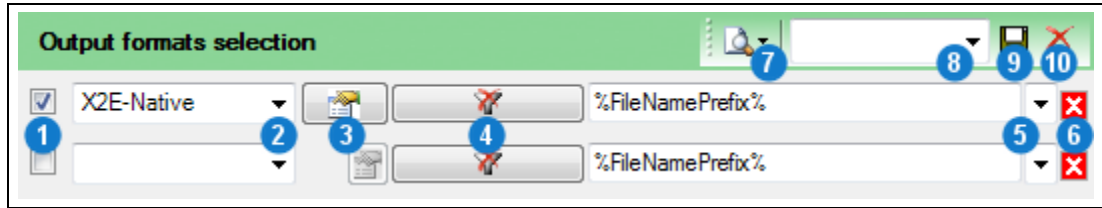

1	Activate	6	Delete
2	Output format	7	Show log file of export filter
3	Filter settings	8	Export settings
4	Interface filter	9	Save this export setting
5	Attributes	10	Delete this export setting

Create export filters:

- ▶ Select the desired output format (2). (→ Output formats)
- ▶ Check the settings of the selected output format (3).
- ▶ Filter the exported interface channels (4).



Special attributes

You can also separately change the original filename for each export filter by means of special attributes. Select the desired attribute from the respective drop-down list (5).

Repeat the process to combine multiple attributes.

Create further export filters:

- ▶ Repeat as necessary for further table rows.
- ▶ Select the check boxes (1) for all export filters you want to apply.

Delete export filters:

- ▶ Click *Delete* (6).

In case of failure, open the log file of the export filter:

- ▶ Select the desired log file from *Show log file of export filter* (7).

Save export setting for later reuse:

- ▶ Enter a name in the text box *Export settings* (8).
- ▶ Click *Save this export setting* (9).

Load export setting:

- ▶ Select the desired export setting in *Export settings* (8).

Delete export setting:

- ▶ Select the desired export setting in *Export settings* (8).
- ▶ Click *Delete this export setting* (10).

5.14.5 Signal selection

This control element can be found in the following tools: *Configuration* and *Online-Logging*. The right-side view is different depending on whether *Show signal details* (9) or *Manage signal lists* (8) is activated.

Show signal details (9) is activated:

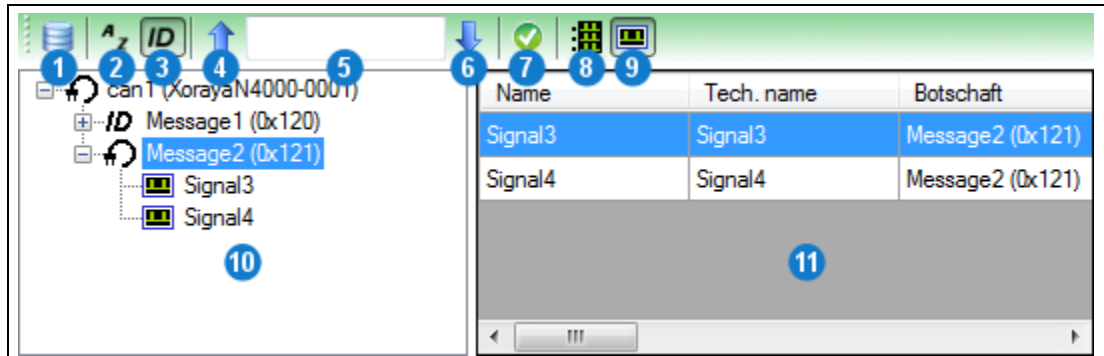

1	Signal description settings	7	Add this signal
2	Sort alphabetically	8	Manage signal lists
3	Sort by ID	9	Show signal details
4	Find previous	10	Signals overview
5	Search box	11	Signal details
6	Find next		

Add signals to signals overview (10):

- ▶ Click *Signal description settings* (1).
- ▶ Add one or more description files to the current signal group. (→ Signal description settings)

Sort the signals overview (10):

- ▶ Click *Sort alphabetically* (2) to sort by message name.
or
- ▶ Click *Sort by ID* (3) to sort by message ID.

Search by message, signal or ID in the signals overview (10):

- ▶ Enter the term or partial term in the search box (5).
- ▶ Click *Find previous* (4).
or
- ▶ Click *Find next* (6).

Display signal details (11):

- ▶ Select a message in the signals overview (10) to view details for all signals of this message.

or

- ▶ Select a signal to view details for this signal.

Add signal:

- ▶ Select the signal in the signal overview (10).

or

- ▶ Select the signal in the signal details (11).
- ▶ Click *Add this signal* (7).

Manage signal lists (8) is activated:

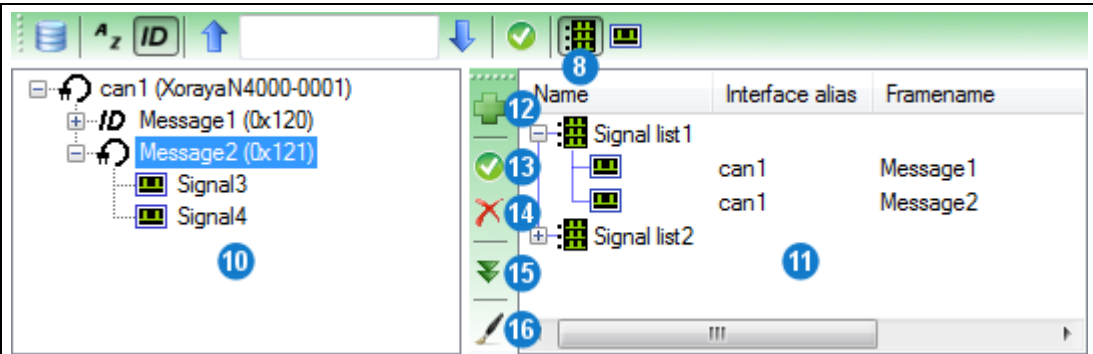

8	Manage signal lists	13	Add signal to list
10	Signals overview	14	Delete signal from list
11	Signal lists	15	Find signal
12	Add new signal list	16	Draw signal

Create new signal list:

- ▶ Click *Add new signal list* (12).

Add signal to signal list:

- ▶ Select the signal list (11).
- ▶ Select the signal in the signals overview (10).
- ▶ Click *Add signal to List* (13).

Delete signal from signal list:

- ▶ Select the signal in the Signal List (11).
- ▶ Click *Delete signal from list* (14).

Delete signal list:

- ▶ Select the signal list (11).
- ▶ Click *Delete signal from list* (14).

Display signal from signal list (11) in the signals overview (10):

- ▶ Select the signal in the signal list (11).
- ▶ Click *Find signal* (15).



Storage location for signals, signals overview and signal lists

Added signals are stored on the connected N4000+.

The signals overview and signal lists are stored on your PC, being thus available for the configuration of other dataloggers.

5.14.6 Signal description settings

This control element can be found in the following tools: *Configuration*, *Online-Logging* and *Viewer*.

Here, load description files and assign them to signal groups.

Supported description file types:

- DBC
- LDF
- FIBEX (XML)
- A2L
- AUTOSAR (ARXML)

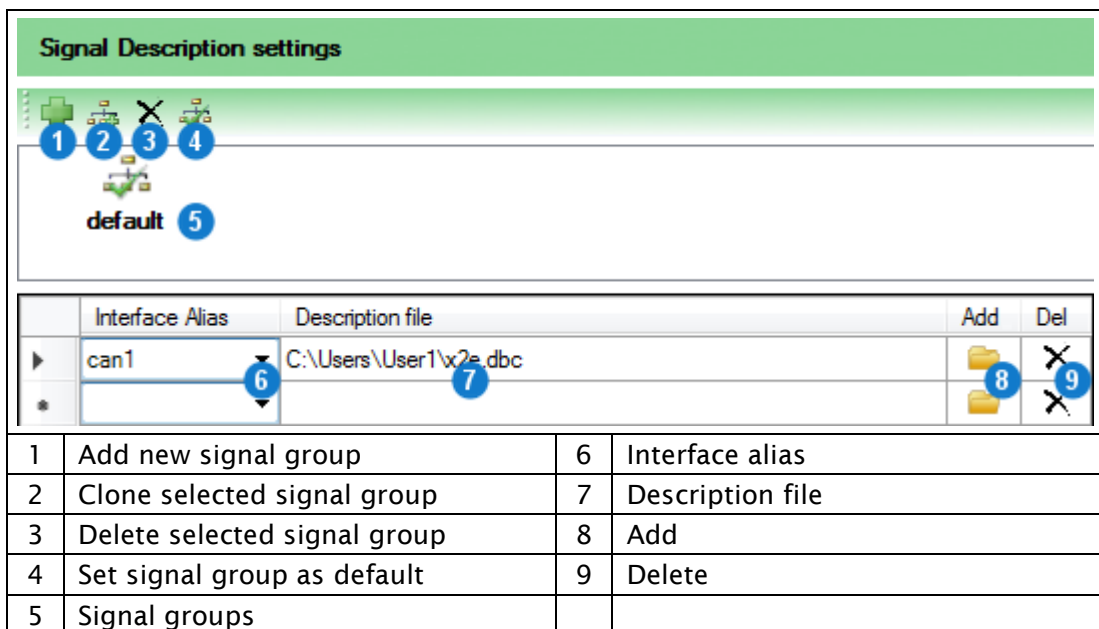

	Interface Alias	Description file	Add	Del
	can1	C:\Users\User1\w2e.dbc		

1	Add new signal group	6	Interface alias
2	Clone selected signal group	7	Description file
3	Delete selected signal group	8	Add
4	Set signal group as default	9	Delete
5	Signal groups		

5.14.7 Create trigger conditions

You use this control element to configure general signal triggers or triggers of the VIDEO, DiagCCP, DiagXCP and Event interfaces.

The following trigger types are available:

- Value compare Raise trigger if a single condition or combined conditions are met
- Signal list Raise trigger if the N4000+ detects one of these signals on the data buses

Value compare:

1	Apply trigger	7	Parenthesise selection
2	Cancel trigger configuration	8	Clear selection
3	Add condition	9	Signal
4	Remove condition	10	Relation
5	Move selection to right	11	Relation type
6	Move selection to left	12	Operator

The following *Relation types* (11) are available:

- $\begin{matrix} 011 \\ 101 \end{matrix}$ Signal value
- # Number of occurrences of this signal
- ⌚ Time since the last occurrence of this signal (in ms)

Add condition:

- ▶ Select an already configured *Signal (9)*. (→ Settings)
- ▶ Select the *Relation (10)* between signal and value.
- ▶ Select the *Relation type (11)*.
- ▶ Depending on the relation type, specify the *Raw value* or the time (in ms). (→ Changing the numbering system)

Combine multiple conditions:

- ▶ Click *Add condition (3)*.
- ▶ Configure this condition as described above.
- ▶ Select the *Operator (12)* that combines this and the previous condition.
- ▶ If required, repeat the above steps to combine further conditions.



Operator precedence

According to the rules of Boolean algebra, the AND operator (&&) precedes the OR operator (||). You can influence precedence by parentheses.

Add parentheses:

- ▶ Click the desired conditions and operators to mark them blue.
- ▶ Click *Parenthesise selection (7)*.
or
- ▶ Click *Move selection to right (5)*.

Remove parentheses:

- ▶ Click the desired conditions and operators to mark them blue.
- ▶ Click *Move selection to left (6)*.



Visualisation of parentheses

The GUI displays conditions of the same precedence level, meaning parenthesised conditions, also on the same horizontal level. The corresponding operator is connected to the left border.

Being further to the right is equivalent to a higher precedence. Therefore, *Parenthesise selection (7)* and *Move selection to right (5)* have the same effect.

Apply conditions:

- ▶ Select the *Execution time*.
 - ▶ If necessary, change the automatically generated *Description*.
 - ▶ Only for event triggers:
Under *Arguments*, specify the payload (32 bit) and the ID (8 bit) of the event message to be sent.
 - ▶ Click *Apply trigger (1)*.
- The value compare trigger is stored on the N4000+.

Signal list:

Trigger type Signal list

Description: On Message1.Signal2 & Message2.Signal3

Signal:

- Message1.Signal1
- Message1.Signal2
- Message2.Signal3
- Message2.Signal4

Arguments:

payload	0x 0
msg_id	0x 0

1 Apply trigger 2 Cancel trigger configuration

Add signal list trigger:

- ▶ Select the check boxes of the desired signals.
 - ▶ If required, change the automatically generated *Description*.
 - ▶ Only for event triggers:
Under *Arguments*, specify the payload (32 bit) and the ID (8 bit) of the event message to be sent.
 - ▶ Click *Apply Trigger (1)*.
- The signal list trigger is stored on the N4000+.

5.14.8 Graph View

This control can be found in the following tools: *Online-Logging*, *Hdd-Download* and *Viewer*.

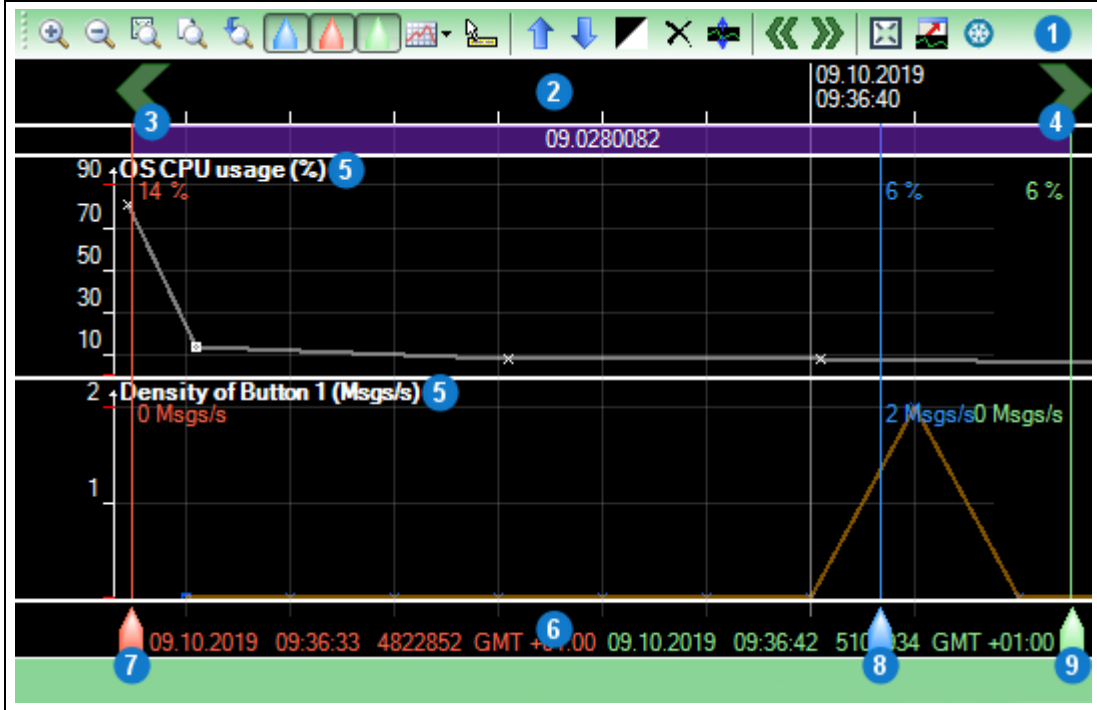





















1	Toolbar	6	Time pointer area
2	Timeline	7	Red time pointer
3	To the left	8	Blue time pointer*
4	To the right	9	Green time pointer
5	Graph name		

* Only in *Viewer*

- ▶ Click and drag over an area to zoom in.
- ▶ Double-click to jump to the corresponding period in the *Data* panel of the *Viewer* tool.
- ▶ Click the timeline (2) to display arrows, which allow you to move in small steps to the left (3) and right (4).
- ▶ Click the respective graph title (5) to select that graph.
- ▶ Left-click in the time pointer area (6) to set the red time pointer (7).
- ▶ Right-click in the time pointer area (6) to set the green time pointer (9).

The blue time pointer (8) represents the currently selected record in the *Data* panel of the *Viewer* tool.

The following table describes the control elements on the toolbar (1) from left to right.

Symbol	Function
	Zoom in
	Zoom out
	Adjust the zoom level so that the Fine zone is visible
	Adjust the zoom level so that the entire measurement is visible
	Switch between previous and current zoom level
	Change the visibility of the blue time pointer, which represents the current position in the <i>Data</i> panel*
	Change the visibility of the red time pointer, which represents the left-clicked position.
	Change the visibility of the green time pointer, which represents the right-clicked position.
	Connect the graph points as lines, curves, stairs or do not connect Draw the graph points or not
	Display the time and value of the current mouse position next to the mouse pointer
	Move the selected graphs up
	Move the selected graphs down
	Switch colour of background and labelling
	Close the selected graphs
	Display graphs over the full height of the window
	Move to previous time area
	Move to next time area
	Defines the currently visible time area as the Fine zone
	Open Graph View in separate window*
	Freeze graph drawing**

* Only in *Viewer* ** Only in *Online-Logging*

6 Maintenance

6.1 Safety measures



DANGER

Electric shock caused by damage to components

Any damage to the N4000+, power source or power supply cable may cause an electric shock.

- ▶ Switch on the N4000+ only if all components appear undamaged.
- ▶ Only commission the N4000+ after a proper installation or repair.
- ▶ Check the power cable regularly for defects to prevent damage to the power source.
- ▶ Always install the N4000+ in de-energised status.



CAUTION

Device damage due to short circuit

Bent connector pins pose a short circuit risk. This can lead to abnormal behaviour or destruction of the N4000+.

Likewise, devices connected to the measurement setup may be also compromised.

- ▶ Make sure that connector pins are not bent.
- ▶ Check the N4000+ regularly for any deficiencies.



CAUTION

Safety defects due to incorrect accessories and spare parts

Accessories and spare parts that have not been recommended by X2E GmbH negatively affect the safety, functionality and precision of the N4000+.

X2E GmbH shall assume no responsibility whatsoever or honour any warranty for damages arising from non-recommended accessories and spare parts or incorrect use.

- ▶ Use only accessories recommended by X2E GmbH and original spare parts.

6.2 Cleaning



CAUTION

Device damage due to pollution

Avoid any contamination in plugs and sockets to ensure a reliable contact.

- ▶ Keep the N4000+ clean.



CAUTION

Device damage due to penetration of dust or liquids

Dust or moisture inside the N4000+ may cause abnormal behaviour or destruction of the device.

- ▶ Only operate the N4000+ with a closed housing.
 - ▶ Do not operate the N4000+ outdoors.
 - ▶ Do not operate the N4000+ outside the specified temperature range.
 - ▶ Turn off the N4000+ and disconnect it from the power supply before you start cleaning.
-

Observe the following instructions to prevent damage to the N4000+:

- ▶ If necessary, clean the N4000+ with a damp, soft, lint-free cloth.
- ▶ Make sure that no moisture penetrates into the housing.
- ▶ Use only clear water and a mild detergent to moisten the cloth. Avoid sprays, solvents, alcohol or abrasive cleaners.
- ▶ Only reconnect the N4000+ to the power supply if the housing appears completely dry.

6.3 Repair



CAUTION

Device damage due to device opening

Unauthorised opening of the N4000+ can lead to abnormal behaviour or destruction of the device.

- ▶ Never open the N4000+.
 - ▶ Contact X2E GmbH should maintenance and repairs be required.
-

Upon malfunction or defect, return the N4000+ without any accessories to X2E GmbH. You can find the address on page 2 of this manual.

Before submission, please take the following measures:

- ▶ Clean the N4000+. (→ Cleaning)
- ▶ Pack the N4000+ safely in its original packaging.
- ▶ Include the completed return form. You can download this form from the X2E Wiki or receive via email upon request to xoraya-return@x2e.de.

7 Storage, transport and disposal

7.1 Storage

If the N4000+ will remain unused for an extended time, we recommend storing it in the original packaging.

Adopt the following precautions to avoid damage to the N4000+:

- ▶ Protect the N4000+ from intense sun, heat, as well as from severe shocks.
- ▶ Do not place heavy objects on the N4000+.
- ▶ Store the N4000+ in a dry, dust-free and ESD safe area.

7.2 Transport

Transport the N4000+ only in the original packaging.

7.3 Disposal

Please observe local legal requirements should you need to dispose of the N4000+.



Within the European Union, the disposal is regulated by national regulations for electrical devices, which are based on the Directive 2012/19 / EU of the European Parliament and of the Council on electrical and electronic equipment waste.

Therefore, electrical and electronic equipment must not be disposed of with household waste.



The N4000+ requires batteries. Used batteries may not be disposed with household waste because, amongst other, they contain lead, cadmium or mercury.

8 Appendix

8.1 Technical data

The following table provides an overview of technical data and properties of the N4000+.

Property	Value/Characteristic
Timestamp resolution	100 ns for all interfaces
Storage capacity	256 GB (internal) 1 TB (external)
Operating temperature range*	-40 to +65 °C
Air humidity range	10 to 95 % (non-condensing)
Supply voltage	12 V DC (temporarily from 6 to 32 V)
Current consumption	(12 V, standard configuration, everything connected) <ul style="list-style-type: none"> ▪ PCAPs are charged: 7.0 A ▪ PCAPs are not charged: 4.5 A (until about 10 s after power on)
Standby current consumption	Max. 1 mA (at 12 V)
Dimensions (H x W x D)	70 x 255 x 207 mm (with impact protection)
Housing protection type	IP 20, NEMA Type 1
Pollution degree	Pollution degree 3
Altitude	Max. 2000 m
Automatic sleep mode	Wakeable interfaces and signals: <ul style="list-style-type: none"> ▪ CAN ▪ FlexRay ▪ LIN ▪ RS-232 ▪ Wake input ▪ Trigger
Recording modes	<ul style="list-style-type: none"> ▪ Over TCP/IP on the PC ▪ On internal storage medium or externally on XORAYA ESU ▪ Combination of both modes
Allowed voltage on additional ports	<ul style="list-style-type: none"> ▪ Digital In: 0 to 24 V DC ▪ Analog: 0 to 60 V DC ▪ USB Host: 0 to 6 V DC ▪ eSATA: 0 V DC

* Are the internal temperatures too high, for example due to insufficient air flow, the data logger automatically switches off for safety reasons.

8.2 N4000+ pin assignments

The following tables show the pin assignments of the interfaces and of the power/trigger/wake port. Figures show the external view of the N4000+ contacts.

8.2.1 6x 1000Base-T1

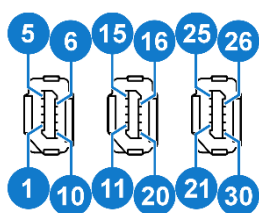

3x HARTING ix Industrial type A

Pin	Function
1	CH 2 P
2	CH 2 N
3	GND
4	-
5	-
6	CH 1 P
7	CH 1 N
8	GND
9	-
10	-
11	CH 4 P
12	CH 4 N
13	GND
14	-
15	-
16	CH 3 P
17	CH 3 N
18	GND
19	-
20	-
21	CH 6 P
22	CH 6 N
23	GND
24	-
25	-
26	CH 5 P
27	CH 5 N
28	GND
29	-
30	-

8.2.2 12x 100Base-T1

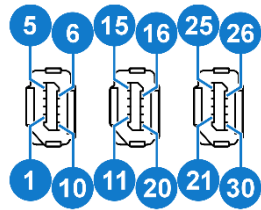

3x HARTING ix Industrial type A

Pin	Function
1	CH 2 P
2	CH 2 N
3	GND
4	CH 4 P
5	CH 4 N
6	CH 1 P
7	CH 1 N
8	GND
9	CH 3 P
10	CH 3 N
11	CH 6 P
12	CH 6 N
13	GND
14	CH 8 P
15	CH 8 N
16	CH 5 P
17	CH 5 N
18	GND
19	CH 7 P
20	CH 7 N
21	CH 10 P
22	CH 10 N
23	GND
24	CH 12 P
25	CH 12 N
26	CH 9 P
27	CH 9 N
28	GND
29	CH 11 P
30	CH 11 N

8.2.3 2x Digital Out

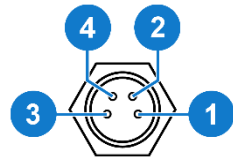

Binder M8 Series 718, F

Pin	Function
1	D 1
2	GND
3	D 2
4	GND

8.2.4 10x CAN

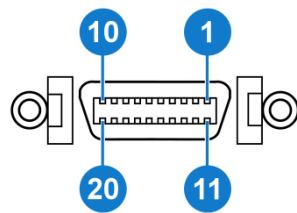

3M, 10220-M218 PE

Pin	Function
1	CAN 1 High
2	CAN 1 Low
3	CAN 2 High
4	CAN 2 Low
5	CAN 3 High
6	CAN 3 Low
7	CAN 4 High
8	CAN 4 Low
9	CAN 10 High
10	CAN 10 Low
11	CAN 5 High
12	CAN 5 Low
13	CAN 6 High
14	CAN 6 Low
15	CAN 7 High
16	CAN 7 Low
17	CAN 8 High
18	CAN 8 Low
19	CAN 9 High
20	CAN 9 Low

8.2.5 24x LIN

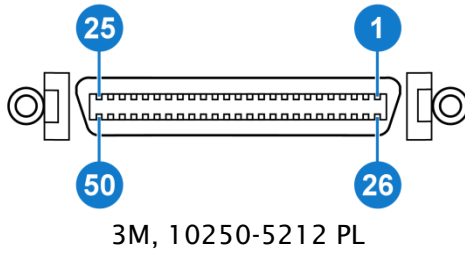

Pin	Function
1	LIN 1
2	LIN 2
3	LIN 3
4	LIN 4
5	LIN 5
6	LIN 6
7	LIN 7
8	LIN 8
9	LIN 9
10	LIN 10
11	LIN 11
12	LIN 12
13	LIN 13
14	LIN 14
15	LIN 15
16	LIN 16
17	LIN 17
18	LIN 18
19	LIN 19
20	LIN 20
21	LIN 21
22	LIN 22
23	LIN 23
24	LIN 24
33	VBAT
34	VBAT
35	GND
36	GND

8.2.6 4x Digital In

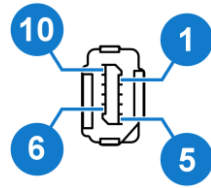

HARTING ix Industrial type B

Pin	Function
1	D 4
2	-
3	D 1
4	-
5	D 2
6	D 3
7	-
8	-
9	GND
10	-

8.2.7 8x RS-232

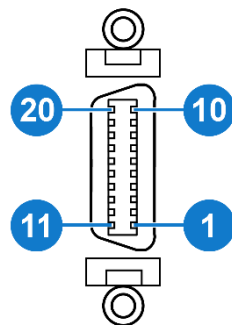

3M, 10220-5212PL

Pin	Function
1	RX 8
2	TX 8
3	RX 7
4	TX 7
5	RX 6
6	TX 6
7	RX 5
8	TX 5
9	RX 4
10	TX 4
11	GND
12	TX 1
14	RX 1
16	TX 2
18	RX 2
19	RX 3
20	TX 3

8.2.8 6x Analog

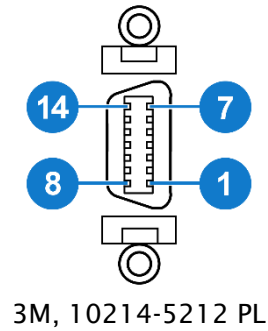

Pin	Function
1	A 6 N
2	A 5 N
3	A 6 P
4	A 5 P
5	A 4 N
6	-
7	A 4 P
8	A 3 N
9	A 2 N
10	A 3 P
11	A 2 P
12	A 1 N
13	-
14	A 1 P

8.2.9 2x FlexRay

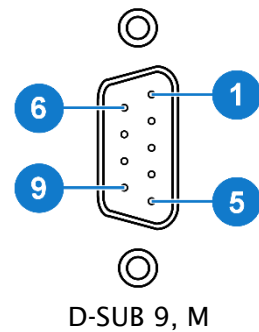

Pin	Function
1	-
2	FR BM A
3	GND
4	FR BM B
5	-
6	-
7	FR BP A
8	FR BP B
9	-

8.2.10 Power/trigger/wake

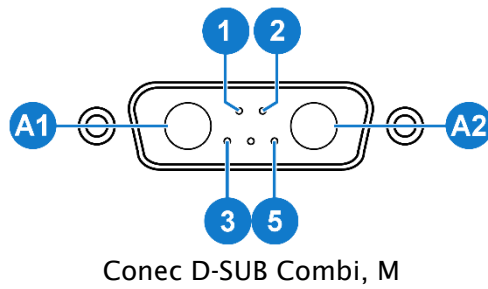

Pin	Function
A1	GND
A2	VIN
1	-
2	Wake
3	Trigger/Wake GND
4	Trigger
5	-

8.3 Output formats

Die folgende Tabelle zeigt eine Übersicht aller für den N4000+ relevanten Ausgabeformate, die Sie beim Herunterladen und beim Konvertieren von Logdaten wählen können.

Ausgabeformat	Dateiendung	Exportierte Nachrichtentypen
X2E-Nativ	DLI/DLM/DLF/DLS	alle
X2E Ascii	DLASC	alle
Carmen-Journal (V3.0)	JRL	alle
Wireshark PCAP	PCAP	Ethernet
Vector BLF	BLF/DBC	alle
Vector ASC	ASC	alle
XAA für GNLog	XAA	GNLog, RS-232, Event, System
DLT-Autosar (V4.0)	DLT	DLT, Event, System
System Events	TXT	Event, System
Raw für RS232/RawSocket	RAW	RS-232, RawSocket, Event
CSV für Analog/CCP/PSI5	CSV	Analog, DiagCCP, DiagXCP, PSI5
CSV für Signale	SCSV/IFF	CAN- und FlexRay-Signale
Video extrahieren	JPG/MP4/H264	Video, Ethernet
MDF Export (V4.1)	MF4	DiagCCP- und DiagXCP-Signale, Event



Eigene Ausgabeformate

Mit dem XORAYASDK (Software Development Kit) können Sie eigene Ausgabeformate schreiben und in die XORAYASuite importieren.

Für weitere Informationen und Beispielcode kontaktieren Sie bitte X2E.

In den folgenden Unterkapiteln finden Sie für jedes Ausgabeformat Beschreibungen der jeweiligen Eigenschaften.

8.3.1 X2E-Native

Einstellung	Beschreibung	Standard
NewDLIonMaxFileSizeReached	neue Infodatei (DLI) für jede Binärdatei (DLF) anlegen	aus
MaxFileSize_MB (x)	maximale Dateigröße einer Binärdatei (DLF) in MB	100
WriteStatistics	Statistikdatei (DLS) anlegen	aus
CreateZIP	Logdateien als komprimiertes ZIP-Archiv speichern	aus

8.3.2 X2E Ascii

Einstellung	Beschreibung	Standard
ShowTimestamp	Zeitstempel für jede Nachricht ausgeben	ein
ShowCounter	Zähler für jede Nachricht ausgeben	ein
ShowTimestampDelta	Differenz zum Zeitstempel der vorherigen Nachricht ausgeben	aus
ShowDebug	Debug-Informationen ausgeben	aus
ShowSystem	Nachrichten der System-Schnittstelle ausgeben	aus
ShowMediaConfig	komplette Konfiguration der Schnittstellenkanäle ausgeben	ein
ShowFormatDescription	prinzipieller Nachrichtenaufbau jeder Schnittstelle ausgeben	ein
ShowInterfaces	Auflistung der Schnittstellenkanäle mit interner ID, Alias und BUS-ID ausgeben	ein

8.3.3 Carmen-Journal

Einstellung	Beschreibung	Standard
Ein Journal schreiben für alle Sessions	alle gewählten Sessions zusammen in einer Datei ausgeben	aus

8.3.4 Wireshark PCAP

Einstellung	Beschreibung	Standard
FileFormat(TcpDump)	Zeitstempel mit Mikrosekunden-Auflösung verwenden	ein
FileFormat(NanoSecond)	Zeitstempel mit Nanosekunden-Auflösung verwenden	aus
NewPCAPonMaxFileSizeReached	neue Datei anlegen, wenn maximale Dateigröße erreicht wird	aus
MaxFileSize_MB (x)	maximale Dateigröße in MB	100

8.3.5 Vector BLF

Einstellung	Beschreibung	Standard
UseCommonStartTimeStamp	einheitlichen Start-Zeitstempel verwenden	aus
WriteCANmsg4Trigger (x)	Trigger als virtuelle CAN-Nachrichten ausgeben: <ul style="list-style-type: none"> ▪ benutzerdefiniert oder ▪ automatisch generiert (kompatibel mit CANoe) 	

8.3.6 Vector ASC

Einstellung	Beschreibung	Standard
NewASConMaxFileSizeReached	neue Datei anlegen, wenn maximale Dateigröße erreicht wird	aus
MaxFileSize_MB (x)	maximale Dateigröße in MB	100
WriteCarmenBusMapping	Nummer und zugehörigen Alias der Schnittstellenkanäle zur Weiterverarbeitung mit CARMEN ausgeben	aus
UseEcosCompatMode	fallende Flanken von Button-Triggern nicht ausgeben (aus Kompatibilitätsgründen unter Umständen erwünscht)	aus
WriteOneFilePerInterface	eigene Datei für jeden Schnittstellenkanal ausgeben	aus
WriteCANmsg4Trigger (x)	Trigger als virtuelle CAN-Nachrichten ausgeben: <ul style="list-style-type: none"> ▪ benutzerdefiniert oder ▪ automatisch generiert (kompatibel mit CANoe) 	

8.3.7 XAA for GNLog

Einstellung	Beschreibung	Standard
NewXAAonMaxFileSizeReached	neue Datei anlegen, wenn maximale Dateigröße erreicht wird	aus
MaxFileSize_MB (x)	maximale Dateigröße in MB	100

8.3.8 DLT-Autosar

Einstellung	Beschreibung	Standard
ConnectionEvents	TCP-Connection-Events ausgeben	aus
NewDLTonMaxFileSizeReached	neue Datei anlegen, wenn maximale Dateigröße erreicht wird	aus
MaxFileSize_MB (x)	maximale Dateigröße in MB	100

8.3.9 System Events

Einstellung	Beschreibung	Standard
Ein Journal schreiben für alle Sessions	alle gewählten Sessions zusammen in einer Datei ausgeben	aus

8.3.10 Raw for RS232/RawSocket

Einstellung	Beschreibung	Standard
NewRAWonMaxFileSizeReached	neue Datei anlegen, wenn maximale Dateigröße erreicht wird	aus
MaxFileSize_MB (x)	maximale Dateigröße in MB	100
Extension (x)	Dateiendung	raw
TimestampPrefix	Zeitstempel-Präfix für jede Nachricht ausgeben	aus
AllowMarker	Events als Marker ausgeben Voraussetzungen: <ul style="list-style-type: none"> ▪ <i>TimestampPrefix</i> ist ein ▪ Event-Nachrichtentyp ist im Schnittstellenfilter aktiviert 	aus

8.3.11 CSV for Analog/CCP/PSI5

Einstellung	Beschreibung	Standard
WriteTrigger	Trigger ausgeben	aus
WriteButtonFallAsTrigger	fallende Flanken von Button-Triggern ausgeben	aus
WriteButtonRiseAsTrigger	steigende Flanken von Button-Triggern ausgeben	aus
WriteOneFile	alle Nachrichten einer Schnittstelle in einer Datei ausgeben statt getrennt für jeden Kanal	aus

8.3.12 CSV for Signale

Einstellung	Beschreibung	Standard
Raster	wenn innerhalb dieser Rasterzeit (in ms) mehrere Nachrichten eines Signals auftreten, wird der letzte Wert verwendet 0: Raster deaktiviert	0
AddSignalDefinition (x)	selbst erstellte Signalliste hinzufügen (➔ Signal selection)	
NewSCSVonMaxFileSizeReached	neue Datei anlegen, wenn maximale Dateigröße erreicht wird	aus
IFF-Format	IFF- statt SCSV-Dateiformat verwenden	aus
ExportRawValue	Rohdatenwerte der Signale ausgeben	ein

8.3.13 Video Extractor

Einstellung	Beschreibung	Standard
DoJPEG	Bilder im JPEG-Format ausgeben	ein
DoMPEG	Videos im MPEG-2-Format ausgeben	ein
DoH264	Videos im MPEG-4-/H.264-Format ausgeben	aus

8.3.14 MDF Export

Einstellung	Beschreibung	Standard
a2l_file_alternative_path (x)	Alternativ-Pfad für A2L-Datei	
TimezoneOffsets_min (x)	Zeitverschiebung zur UTC in Minuten: <Zeitzone> <Sommerzeit>	0 0
NewFileOnMaxFileSizeReached	neue Datei anlegen, wenn maximale Dateigröße erreicht wird	aus
MaxPartFileSizeMegaBytes (x)	maximale Dateigröße in MB	100
DTBlockSizeMegaBytes (x)	Größe eines Datenblocks in MB	1
compression	Kompression aktivieren	aus
AddSignalDefinition (x)	selbst erstellte Signalliste hinzufügen (➔ Signal selection)	
AddSignalDefinitionToFiles	für jedes Signal der hinzugefügten Signalliste eine eigene Datei ausgeben	aus

Declaration of conformity



X2E GmbH
Entwicklungszentrum
Große Ahlmühle 19
76865 Rohrbach
Tel. +49 6349 99599 100
Fax +49 6349 99599 109

Declares the conformity for the product

Product name:

DATENLOGGER XORAYA N4000+

According to the following requirements:

EMC Directive 2014/30/EU

OF THE EUROPEAN PARLIAMENT AND OF THE COUNCIL

of 26 February 2014 on the harmonisation of the laws of the Member States relating to electromagnetic compatibility and repealing Directive 2004/108/EC.

The following standards have been applied:

DIN EN 61326-2-1 :2013

DIN EN 55011 :2016 + A1:2017

DIN EN 61000-4-2 :2009

DIN EN 61000-4-3 :2006 + A1:2008 + A2:2010

DIN EN 61000-4-4 :2012

DIN EN 61000-4-6 :2009

IEC 61010-1:2010, IEC 61010-1:2010/AMD1:2016

K. Wenz CEO
Signature: / Position in company:

Rohrbach, 01.12.2021
Place and date:



X2E GmbH
Grosse Ahlmühle 19
76865 Rohrbach
GERMANY

Phone	+49 6349 99599 200
E-mail	xoraya@x2e.de
Internet	www.x2e.de
Wiki	wiki.x2e.de