

IQC Check Dimension 重点管控尺寸	
①	3.8±0.05
②	3 ^{+0.2} ₀
③	
④	
⑤	

REVISIONS 更改说明			
REV	DESCRIPTION 描述	DATE 日期	APPROVED 批准
00			

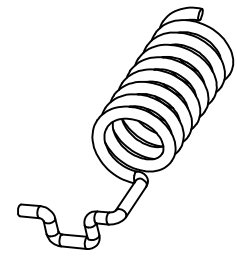
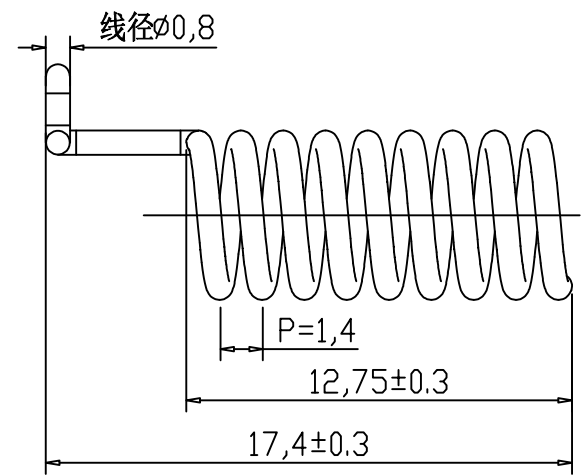
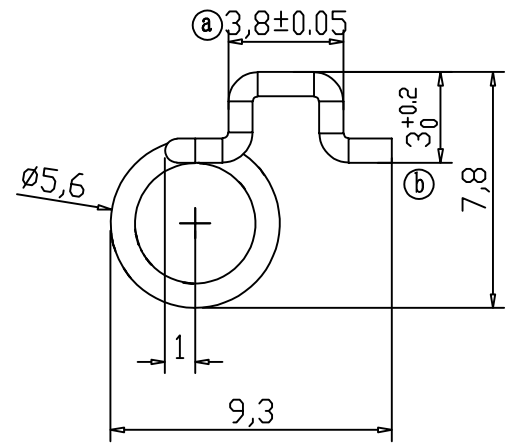

比例 2:1

NOTES:

- 带圈"O"序号为重点检控尺寸;
The serial number with circle "o" is the key prosecution size
- 表面要求光滑, 无脏污, 平整、无变形等缺陷; 边缘不得有尖锐毛刺;
The surface shall be smooth, free of dirt, flatness and deformation;
Edges shall be free from sharp burrs.
- 材质: 黄铜, 盐雾测试48小时以上
Material: brass, salt spray test for more than 48 hours
- 所用材料需符合ROHS绿色环保标准;
ROHS green standards for materials used
- 未注尺寸以3D图为准;
Dimensions not noted shall be 3D drawing;
- Gain: 1dbi;
- 生产地址: 广东省东莞市茶山镇茶山村塘环岭工业区D栋;
Production address: Building D, Tanghuanling Industrial Zone, Chashan Village,
Chashan Town, Dongguan City, Guangdong Province;

APPROVED MFG LIST	
MFG	MPN
① AOXIANG HARDWARE (DONGGUAN) CO., LTD	Y. 1. 33. 010027
② _____	_____
③ _____	_____
④ _____	_____

ANY MFG NOT LISTED ABOVE MUST
BE APPROVED IN WRITING BY X-SENSE

TOLERANCES (UNLESS OTHERWISE STATED)		
DECIMALS	ANGLES	
尺寸范围	重点管控	非重点管控
X>200mm	±0.25mm	±0.50mm
100<X≤200mm	±0.20mm	±0.40mm
50<X≤100mm	±0.15mm	±0.30mm
10<X≤50mm	±0.10mm	±0.20mm
X≤10mm	±0.05mm	±0.10mm

X-SENSE		深圳市安室智能有限公司 X-Sense innovations Co., Ltd.	
PART NAME: 零件名称:	Spring Antenna	DESIGN 设计:	江 健
MODEL NAME: 产品型号:	STH51	CHECK 审核:	
INTERNAL NUMBER 物料编号:	Y. 1. 33. 010027	APPROVE 批准:	
VERSION 版本:	V1	DATE 日期:	20230625
		MATERIAL 材质:	Brass
		UNIT 单位:	MM
		VIEW 视角:	
		SCALE 比例:	2:1