

# FCC Radio Test Report

## FCC ID: 2AU49-DA16200ME

This report concerns: **Original Grant**

**Project No.** : 1910C137  
**Equipment** : WiFi Module  
**Brand Name** : Dialog  
**Test Model** : DA16200MOD-AAE4WA32  
**Series Model** : N/A  
**Applicant** : Dialog Semiconductor Korea Inc.  
**Address** : 7th SiliconPark, 35, Pangyo-ro 255 beon-gil, Bundang-gu, Seongnam-si, Gyeonggi-do (Zip 13486), Korea  
**Manufacturer** : Iton Technology Corp.  
**Address** : 7 Floor East, Building C, Shenzhen International InnovationCenter, No. 1006 Shennan Road, Futian District, Shenzhen, China  
**Factory** : Iton Technology Corp.  
**Address** : 7 Floor East, Building C, Shenzhen International InnovationCenter, No. 1006 Shennan Road, Futian District, Shenzhen, China  
**Date of Receipt** : Nov. 07, 2019  
**Date of Test** : Nov. 08, 2019 ~ Nov. 28, 2019  
**Issued Date** : Dec. 13, 2019  
**Report Version** : R00  
**Test Sample** : Engineering Sample No.: DG2019110653  
**Standard(s)** : FCC Part15, Subpart C (15.247)  
ANSI C63.10-2013  
KDB 558074 D01 15.247 Meas Guidance v05r02

The above equipment has been tested and found compliance with the requirement of the relative standards by BTL Inc.

*Vincent Tan*

Prepared by : Vincent Tan

*Ethan Ma*

Approved by : Ethan Ma



Certificate #5123.02

Add: No.3, Jinshagang 1st Road, Shixia, Dalang Town, Dongguan, Guangdong, China.

Tel: +86-769-8318-3000

Web: [www.newbtl.com](http://www.newbtl.com)

**Declaration**

**BTL** represents to the client that testing is done in accordance with standard procedures as applicable and that test instruments used has been calibrated with standards traceable to international standard(s) and/or national standard(s).

**BTL's** reports apply only to the specific samples tested under conditions. It is manufacture's responsibility to ensure that additional production units of this model are manufactured with the identical electrical and mechanical components. **BTL** shall have no liability for any declarations, inferences or generalizations drawn by the client or others from **BTL** issued reports.

The report must not be used by the client to claim product certification, approval, or endorsement by NVLAP, NIST, A2LA, or any agency of the U.S. Government.

This report is the confidential property of the client. As a mutual protection to the clients, the public and ourselves, the test report shall not be reproduced, except in full, without our written approval.

**BTL's** laboratory quality assurance procedures are in compliance with the **ISO/IEC 17025** requirements, and accredited by the conformity assessment authorities listed in this test report.

**BTL** is not responsible for the sampling stage, so the results only apply to the sample as received.

The information, data and test plan are provided by manufacturer which may affect the validity of results, so it is manufacturer's responsibility to ensure that the apparatus meets the essential requirements of applied standards and in all the possible configurations as representative of its intended use.

**Limitation**

For the use of the authority's logo is limited unless the Test Standard(s)/Scope(s)/Item(s) mentioned in this test report is (are) included in the conformity assessment authorities acceptance respective.

Please note that the measurement uncertainty is provided for informational purpose only and are not use in determining the Pass/Fail results.

**Table of Contents****Page**

<b>REPORT ISSUED HISTORY</b>	<b>6</b>
<b>1 . SUMMARY OF TEST RESULTS</b>	<b>7</b>
1.1 TEST FACILITY	8
1.2 MEASUREMENT UNCERTAINTY	8
1.3 TEST ENVIRONMENT CONDITIONS	8
<b>2 . GENERAL INFORMATION</b>	<b>9</b>
2.1 GENERAL DESCRIPTION OF EUT	9
2.2 DESCRIPTION OF TEST MODES	10
2.3 PARAMETERS OF TEST SOFTWARE	12
2.4 DUTY CYCLE	13
2.5 BLOCK DIAGRAM SHOWING THE CONFIGURATION OF SYSTEM TESTED	14
2.6 SUPPORT UNITS	14
<b>3 . AC POWER LINE CONDUCTED EMISSIONS TEST</b>	<b>15</b>
3.1 LIMIT	15
3.2 TEST PROCEDURE	15
3.3 DEVIATION FROM TEST STANDARD	15
3.4 TEST SETUP	16
3.5 EUT OPERATION CONDITIONS	16
3.6 TEST RESULTS	16
<b>4 . RADIATED EMISSIONS TEST</b>	<b>17</b>
4.1 LIMIT	17
4.2 TEST PROCEDURE	18
4.3 DEVIATION FROM TEST STANDARD	18
4.4 TEST SETUP	19
4.5 EUT OPERATION CONDITIONS	20
4.6 TEST RESULTS - 9 KHZ TO 30 MHZ	20
4.7 TEST RESULTS - 30 MHZ TO 1000 MHZ	20
4.8 TEST RESULTS - ABOVE 1000 MHZ	20
<b>5 . BANDWIDTH TEST</b>	<b>21</b>
5.1 LIMIT	21
5.2 TEST PROCEDURE	21
5.3 DEVIATION FROM STANDARD	21

<b>Table of Contents</b>	<b>Page</b>
5.4 TEST SETUP	21
5.5 EUT OPERATION CONDITIONS	21
5.6 TEST RESULTS	21
<b>6 . MAXIMUM OUTPUT POWER TEST</b>	<b>22</b>
6.1 LIMIT	22
6.2 TEST PROCEDURE	22
6.3 DEVIATION FROM STANDARD	22
6.4 TEST SETUP	22
6.5 EUT OPERATION CONDITIONS	22
6.6 TEST RESULTS	22
<b>7 . CONDUCTED SPURIOUS EMISSIONS</b>	<b>23</b>
7.1 LIMIT	23
7.2 TEST PROCEDURE	23
7.3 DEVIATION FROM STANDARD	23
7.4 TEST SETUP	23
7.5 EUT OPERATION CONDITIONS	23
7.6 TEST RESULTS	23
<b>8 . POWER SPECTRAL DENSITY TEST</b>	<b>24</b>
8.1 LIMIT	24
8.2 TEST PROCEDURE	24
8.3 DEVIATION FROM STANDARD	24
8.4 TEST SETUP	24
8.5 EUT OPERATION CONDITIONS	24
8.6 TEST RESULTS	24
<b>9 . MEASUREMENT INSTRUMENTS LIST</b>	<b>25</b>
<b>10 . EUT TEST PHOTO</b>	<b>27</b>
<b>APPENDIX A - AC POWER LINE CONDUCTED EMISSIONS</b>	<b>31</b>
<b>APPENDIX B - RADIATED EMISSION - 9 KHZ TO 30 MHZ</b>	<b>34</b>
<b>APPENDIX C - RADIATED EMISSION - 30 MHZ TO 1000 MHZ</b>	<b>39</b>
<b>APPENDIX D - RADIATED EMISSION- ABOVE 1000 MHZ</b>	<b>42</b>
<b>APPENDIX E - BANDWIDTH</b>	<b>79</b>
<b>APPENDIX F - MAXIMUM OUTPUT POWER</b>	<b>83</b>

**Table of Contents****Page****APPENDIX G - CONDUCTED SPURIOUS EMISSIONS****85****APPENDIX H - POWER SPECTRAL DENSITY****89**

**REPORT ISSUED HISTORY**

Report Version	Description	Issued Date
R00	Original Issue.	Dec. 13, 2019

## 1. SUMMARY OF TEST RESULTS

Test procedures according to the technical standard(s):

FCC Part15, Subpart C (15.247)				
Standard(s) Section	Test Item	Test Result	Judgment	Remark
15.207	AC Power Line Conducted Emissions	APPENDIX A	PASS	-----
15.247(d) 15.205(a) 15.209(a)	Radiated Emissions	APPENDIX B APPENDIX C APPENDIX D	PASS	-----
15.247(a)(2)	Bandwidth	APPENDIX E	PASS	-----
15.247(b)(3)	Maximum Output Power	APPENDIX F	PASS	-----
15.247(d)	Conducted Spurious Emissions	APPENDIX G	PASS	-----
15.247(e)	Power Spectral Density	APPENDIX H	PASS	-----
15.203	Antenna Requirement	-----	PASS	Note(2)

Note:

- (1) "N/A" denotes test is not applicable in this test report.
- (2) The device what use a permanently attached antenna were considered sufficient to comply with the provisions of 15.203.

### 1.1 TEST FACILITY

The test facilities used to collect the test data in this report is at the location of No.3,Jinshagang 1st Road, Shixia, Dalang Town, Dongguan, Guangdong, China.

BTL's Test Firm Registration Number for FCC: 357015

BTL's Designation Number for FCC: CN1240

### 1.2 MEASUREMENT UNCERTAINTY

ISO/IEC 17025 requires that an estimate of the measurement uncertainties associated with the emissions test results be included in the report. The measurement uncertainties given below are based on a 95% confidence level (based on a coverage factor (k=2))

The BTL measurement uncertainty as below table:

#### A. AC power line conducted emissions test:

Test Site	Method	Measurement Frequency Range	U, (dB)
DG-C02	CISPR	150kHz ~ 30MHz	2.60

#### B. Radiated emissions test:

Test Site	Method	Measurement Frequency Range	Ant. H / V	U, (dB)
DG-CB03	CISPR	9kHz ~ 30MHz	V	3.79
		9kHz ~ 30MHz	H	3.57
		30MHz ~ 200MHz	V	4.88
		30MHz ~ 200MHz	H	4.14
		200MHz ~ 1,000MHz	V	4.62
		200MHz ~ 1,000MHz	H	4.80
		1GHz ~ 6GHz	-	4.58
		6GHz ~ 18GHz	-	5.18
		18GHz ~ 26.5GHz	-	3.62
		26.5GHz ~ 40GHz	-	4.00

Note: Unless specifically mentioned, the uncertainty of measurement has not been taken into account to declare the compliance or non-compliance to the specification.

### 1.3 TEST ENVIRONMENT CONDITIONS

Test Item	Temperature	Humidity	Test Voltage	Tested By
AC Power Line Conducted Emissions	25°C	53%	AC 120V/60Hz	Laughing Zhang
Radiated Emissions-9K-30MHz	25°C	60%	DC 3.3V	Laughing Zhang
Radiated Emissions-30 MHz to 1GHz	24°C	68%	DC 3.3V	Laughing Zhang
Radiated Emissions-Above 1000 MHz	24°C	68%	DC 3.3V	Laughing Zhang
Bandwidth	24°C	66%	DC 3.3V	Jonas Chen
Maximum output power	24°C	66%	DC 3.3V	Laughing Zhang
Conducted Spurious Emissions	24°C	66%	DC 3.3V	Jonas Chen
Power Spectral Density	24°C	66%	DC 3.3V	Jonas Chen



## 2. GENERAL INFORMATION

### 2.1 GENERAL DESCRIPTION OF EUT

Equipment	WiFi Module
Brand Name	Dialog
Test Model	DA16200MOD-AAE4WA32
Series Model	N/A
Model Difference(s)	N/A
Software Version	RTOS-GEN01-01-8803-000000
Hardware Version	DA16200E_V1.0
Power Source	DC voltage supplied from external power supply.
Power Rating	DC 3.3V
Operation Frequency	2412 MHz ~ 2462 MHz
Modulation Type	IEEE 802.11b: DSSS IEEE 802.11g: OFDM IEEE 802.11n: OFDM
Bit Rate of Transmitter	IEEE 802.11b: 11/5.5/2/1 Mbps IEEE 802.11g: 54/48/36/24/18/12/9/6 Mbps IEEE 802.11n: up to 72.2 Mbps
Maximum Output Power	IEEE 802.11b: 17.55 dBm (0.0569 W) IEEE 802.11g: 16.95 dBm (0.0496 W) IEEE 802.11n (HT20): 16.00 dBm (0.0398 W)

Note:

- For a more detailed features description, please refer to the manufacturer's specifications or the user's manual.
- Channel List:

CH01 - CH11 for IEEE 802.11b, IEEE 802.11g, IEEE 802.11n (HT20)							
Channel	Frequency (MHz)	Channel	Frequency (MHz)	Channel	Frequency (MHz)	Channel	Frequency (MHz)
01	2412	04	2427	07	2442	10	2457
02	2417	05	2432	08	2447	11	2462
03	2422	06	2437	09	2452		

### 3. Antenna Specification:

Ant.	Brand	Model Name	Antenna Type	Connector	Gain (dBi)
1	N/A	N/A	Dipole	N/A	2

## 2.2 DESCRIPTION OF TEST MODES

The test system was pre-tested based on the consideration of all possible combinations of EUT operation mode.

Pretest Mode	Description
Mode 1	TX B Mode Channel 01/06/11
Mode 2	TX G Mode Channel 01/06/11
Mode 3	TX N-20 MHz Mode Channel 01/06/11
Mode 4	TX B Mode Channel 11

Following mode(s) as (were) found to be the worst case(s) and selected for the final test.

<b>AC power line conducted emissions test</b>	
Final Test Mode:	Description
Mode 4	TX B Mode Channel 11

<b>Radiated emissions test - Below 1GHz</b>	
Final Test Mode:	Description
Mode 4	TX B Mode Channel 11

<b>Radiated emissions test- Above 1GHz</b>	
Final Test Mode:	Description
Mode 1	TX B Mode Channel 01/06/11
Mode 2	TX G Mode Channel 01/06/11
Mode 3	TX N-20 MHz Mode Channel 01/06/11

<b>Conducted test</b>	
Final Test Mode:	Description
Mode 1	TX B Mode Channel 01/06/11
Mode 2	TX G Mode Channel 01/06/11
Mode 3	TX N-20 MHz Mode Channel 01/06/11

**NOTE:**

- (1) The measurements are performed at the high, middle, low available channels.
- (2) For radiated emission below 1 GHz test, the IEEE 802.11b Channel 11 is found to be the worst case and recorded.
- (3) For radiated emission above 1 GHz test, 1GHz~26.5GHz have been pre-tested and in this report only recorded the worst case. The remaining spurious points are all below the limit value of 20dB.
- (4) For AC Power Line Conducted Emissions are tested at the AC power supply and USB power supply, the USB power supply is found to be the worst case and recorded.

**2.3 PARAMETERS OF TEST SOFTWARE**

Test Software	DA16200_AT_GUI_1.0.0.0		
Frequency (MHz)	2412	2437	2462
IEEE 802.11b	4	3	2
IEEE 802.11g	4	1	5
IEEE 802.11n (HT20)	6	2	2

## 2.4 DUTY CYCLE

If duty cycle is  $\geq 98\%$ , duty factor is not required.  
 If duty cycle is  $< 98\%$ , duty factor shall be considered.  
 The output power = measured power + duty factor.

**IEEE 802.11b**

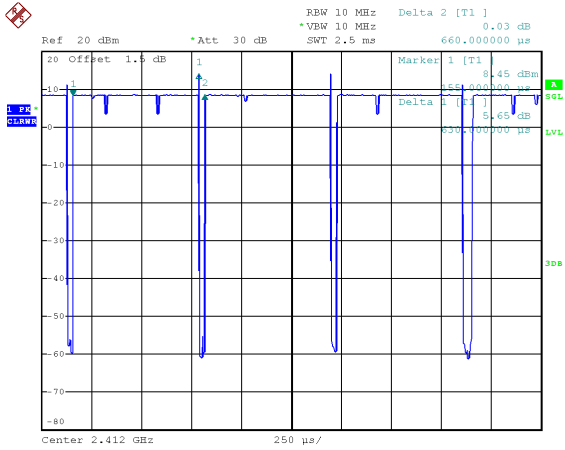

Date: 7.NOV.2019 20:06:59

Duty cycle =  $0.630 \text{ ms} / 0.660 \text{ ms} = 95.45\%$   
 Duty Factor =  $10 \log(1/\text{Duty cycle}) = 0.20$

**IEEE 802.11g**

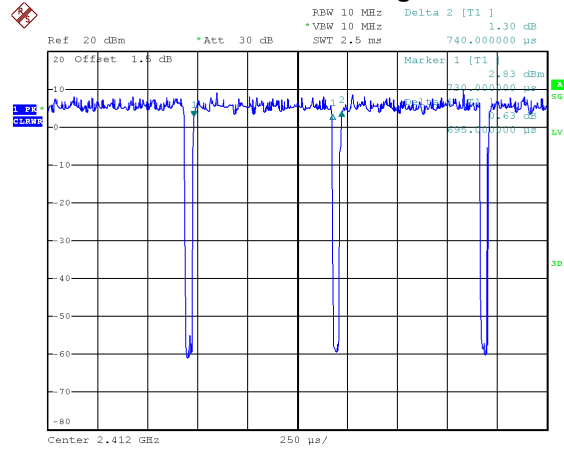

Date: 7.NOV.2019 20:07:20

Duty cycle =  $0.695 \text{ ms} / 0.740 \text{ ms} = 93.92\%$   
 Duty Factor =  $10 \log(1/\text{Duty cycle}) = 0.27$

**IEEE 802.11n (HT20)**

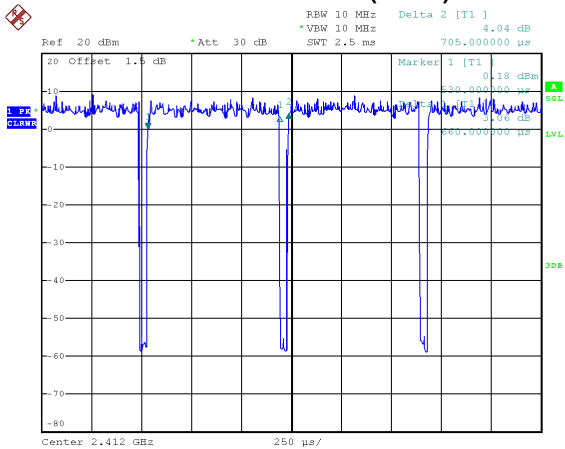

Date: 7.NOV.2019 20:07:34

Duty cycle =  $0.660 \text{ ms} / 0.705 \text{ ms} = 93.62\%$   
 Duty Factor =  $10 \log(1/\text{Duty cycle}) = 0.29$

**NOTE:**

For IEEE 802.11g and IEEE 802.11n (HT20):  
 For radiated emissions frequency above 1 GHz, the resolution bandwidth of test receiver/spectrum analyzer is 1 MHz and the video bandwidth is 1 kHz (Duty cycle  $< 98\%$ ).

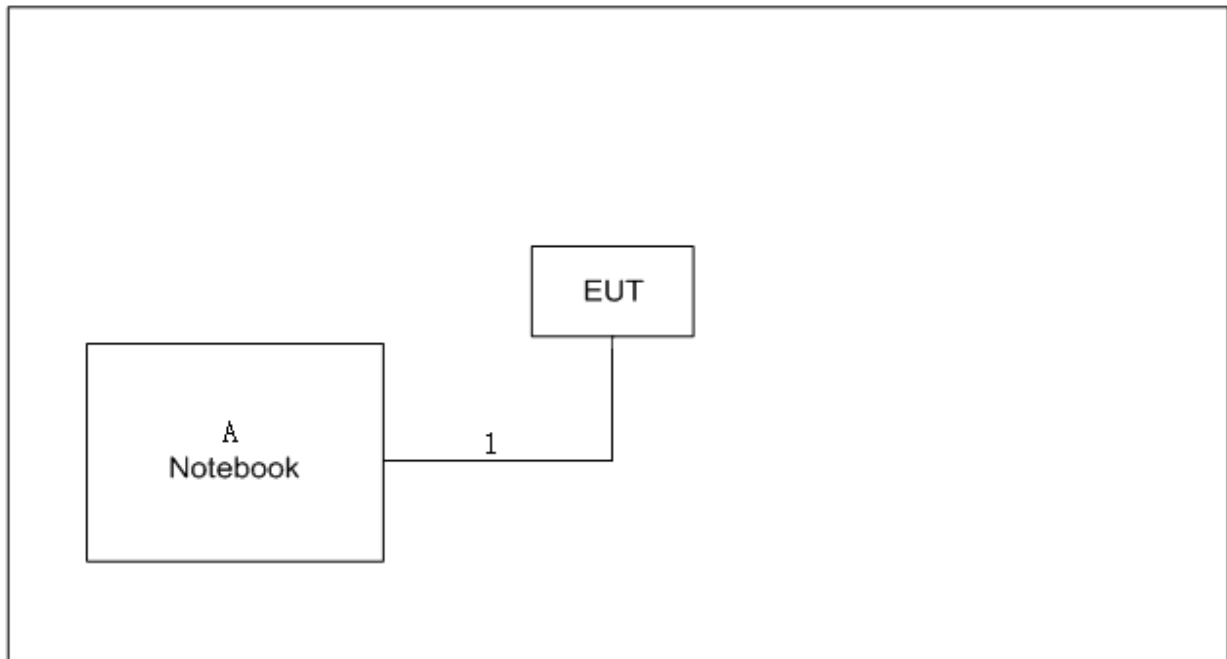
**2.5 BLOCK DIAGRAM SHOWING THE CONFIGURATION OF SYSTEM TESTED****2.6 SUPPORT UNITS**

Item	Equipment	Brand	Model No.	Series No.
A	Notebook	Dell	Inspiron 15-7559	N/A

Item	Cable Type	Shielded Type	Ferrite Core	Length
1	USB Cable	NO	NO	0.8m

### 3. AC POWER LINE CONDUCTED EMISSIONS TEST

#### 3.1 LIMIT

Frequency of Emission (MHz)	Limit (dB $\mu$ V)	
	Quasi-peak	Average
0.15 - 0.50	66 to 56*	56 to 46*
0.50 - 5.0	56	46
5.0 - 30.0	60	50

**NOTE:**

- (1) The tighter limit applies at the band edges.
- (2) The limit of " \* " marked band means the limitation decreases linearly with the logarithm of the frequency in the range.

The following table is the setting of the receiver

Receiver Parameters	Setting
Attenuation	10 dB
Start Frequency	0.15 MHz
Stop Frequency	30 MHz
IF Bandwidth	9 kHz

#### 3.2 TEST PROCEDURE

- a. The EUT was placed 0.8 meters from the horizontal ground plane with EUT being connected to the power mains through a line impedance stabilization network (LISN). All other support equipment powered from additional LISN(s). The LISN provide 50 Ohm/ 50uH of coupling impedance for the measuring instrument.
- b. Interconnecting cables that hang closer than 40 cm to the ground plane shall be folded back and forth in the center forming a bundle 30 to 40 cm long.
- c. I/O cables that are not connected to a peripheral shall be bundled in the center. The end of the cable may be terminated, if required, using the correct terminating impedance. The overall length shall not exceed 1 m.
- d. LISN at least 80 cm from nearest part of EUT chassis.
- e. For the actual test configuration, please refer to the related Item -EUT Test Photos.

#### 3.3 DEVIATION FROM TEST STANDARD

No deviation

### 3.4 TEST SETUP

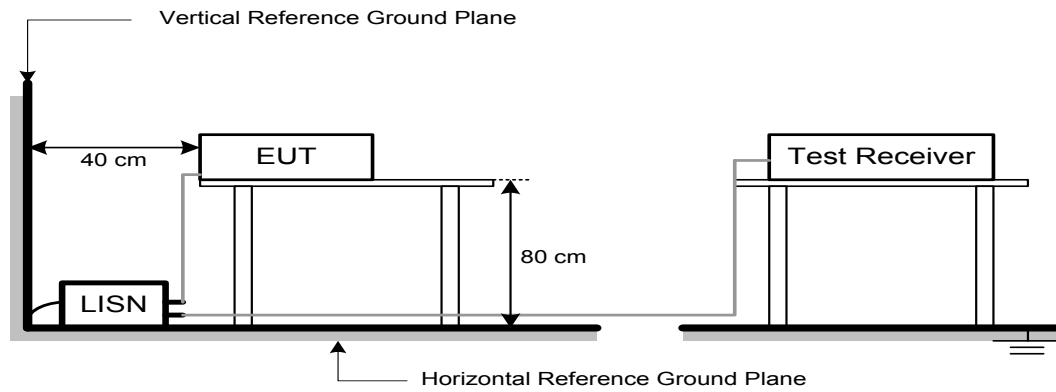

### 3.5 EUT OPERATION CONDITIONS

EUT was programmed to be in continuously transmitting mode.

### 3.6 TEST RESULTS

Please refer to the APPENDIX A.



## 4. RADIATED EMISSIONS TEST

### 4.1 LIMIT

In case the emission fall within the restricted band specified on 15.205(a), then the 15.209(a) limit in the table below has to be followed.

#### LIMITS OF RADIATED EMISSION MEASUREMENT (9 kHz-1000 MHz)

Frequency (MHz)	Field Strength (microvolts/meter)	Measurement Distance (meters)
0.009-0.490	2400/F(kHz)	300
0.490-1.705	24000/F(kHz)	30
1.705-30.0	30	30
30-88	100	3
88-216	150	3
216-960	200	3
Above 960	500	3

#### LIMITS OF RADIATED EMISSION MEASUREMENT (Above 1000 MHz)

Frequency (MHz)	(dBuV/m at 3 m)	
	Peak	Average
Above 1000	74	54

#### NOTE:

- (1) The limit for radiated test was performed according to FCC PART 15C.
- (2) The tighter limit applies at the band edges.
- (3) Emission level (dBuV/m)=20log Emission level (uV/m).

Spectrum Parameter	Setting
Attenuation	Auto
Start Frequency	1000 MHz
Stop Frequency	10th carrier harmonic
RBW / VBW (Emission in restricted band)	1 MHz / 3 MHz for Peak, 1 MHz / 1/T for Average

Receiver Parameter	Setting
Attenuation	Auto
Start ~ Stop Frequency	9 kHz~90 kHz for PK/AVG detector
Start ~ Stop Frequency	90 kHz~110 kHz for QP detector
Start ~ Stop Frequency	110 kHz~490 kHz for PK/AVG detector
Start ~ Stop Frequency	490 kHz~30 MHz for QP detector
Start ~ Stop Frequency	30 MHz~1000 MHz for QP detector

#### 4.2 TEST PROCEDURE

- a. The measuring distance of 3 m shall be used for measurements. The EUT was placed on the top of a rotating table 0.8 meter above the ground at a 3 meter semi-anechoic chamber. The table was rotated 360 degrees to determine the position of the highest radiation.(below 1 GHz)
- b. The measuring distance of 3 m shall be used for measurements. The EUT was placed on the top of a rotating table 1.5 meter above the ground at a 3 meter semi-anechoic chamber. The table was rotated 360 degrees to determine the position of the highest radiation.(above 1 GHz)
- c. The height of the equipment or of the substitution antenna shall be 0.8m or 1.5m; the height of the test antenna shall vary between 1 m to 4 m. Both horizontal and vertical polarizations of the antenna are set to make the measurement.
- d. For each suspected emission, the EUT was arranged to its worst case and then the antenna was tuned to heights find the maximum reading (used Bore sight function).
- e. The receiver system was set to peak and average detect function and specified bandwidth with maximum hold mode when the test frequency is above 1 GHz.
- f. The initial step in collecting radiated emission data is a receiver peak detector mode pre-scanning the measurement frequency range. Significant peaks are then marked and then Quasi Peak detector mode re-measured.
- g. All readings are Peak unless otherwise stated QP in column of Note. Peak denotes that the Peak reading compliance with the QP Limits and then QP Mode measurement didn't perform.  
(below 1 GHz)
- h. All readings are Peak Mode value unless otherwise stated AVG in column of Note. If the Peak Mode Measured value compliance with the Peak Limits and lower than AVG Limits, the EUT shall be deemed to meet both Peak & AVG Limits and then only Peak Mode was measured, but AVG Mode didn't perform. (above 1 GHz)
- i. For the actual test configuration, please refer to the related Item -EUT Test Photos.

#### 4.3 DEVIATION FROM TEST STANDARD

No deviation

**4.4 TEST SETUP**

9 kHz-30 MHz

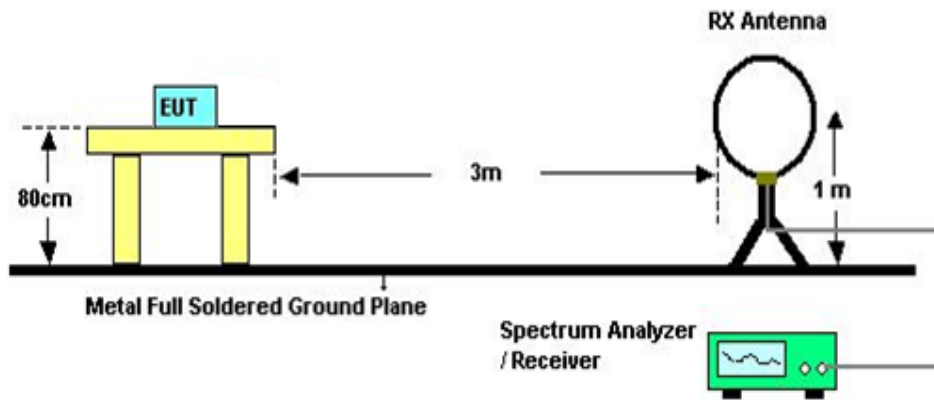

30 MHz to 1 GHz

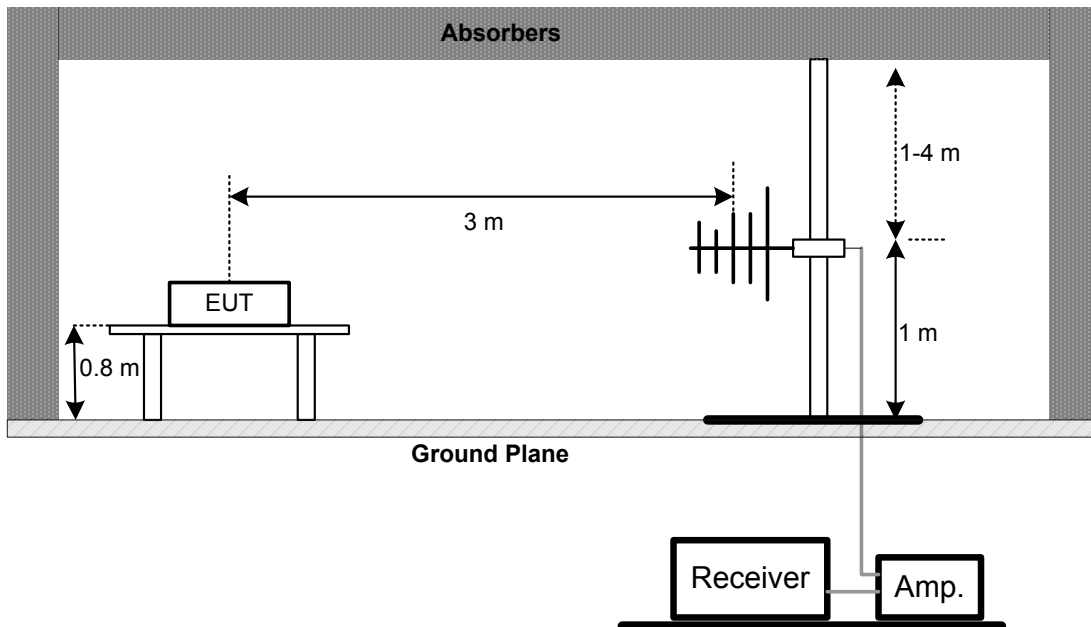

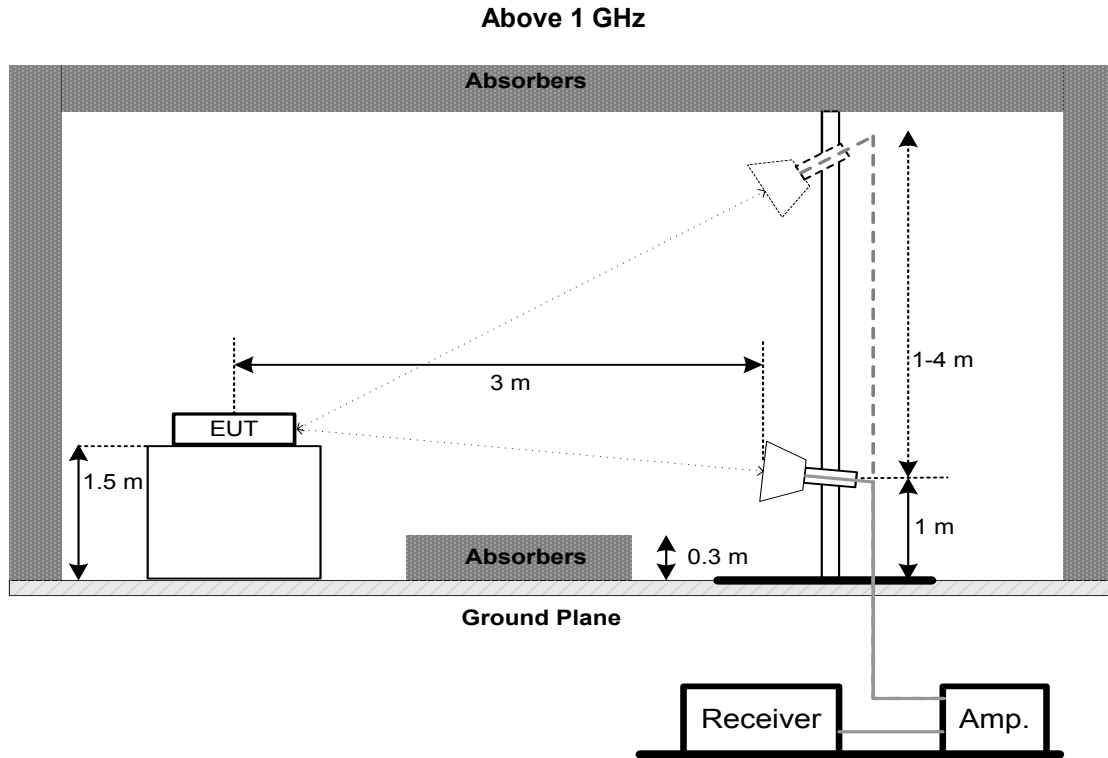

#### 4.5 EUT OPERATION CONDITIONS

The EUT was programmed to be in continuously transmitting mode.

#### 4.6 TEST RESULTS - 9 KHZ TO 30 MHZ

Please refer to the APPENDIX B

Remark:

- (1) Distance extrapolation factor =  $40 \log (\text{specific distance} / \text{test distance})$  (dB).
- (2) Limit line = specific limits (dBuV) + distance extrapolation factor.

#### 4.7 TEST RESULTS - 30 MHZ TO 1000 MHZ

Please refer to the APPENDIX C.

#### 4.8 TEST RESULTS - ABOVE 1000 MHZ

Please refer to the APPENDIX D.

Remark:

- (1) No limit: This is fundamental signal, the judgment is not applicable.  
For fundamental signal judgment was referred to Peak output test.

## 5. BANDWIDTH TEST

### 5.1 LIMIT

FCC Part15, Subpart C (15.247)		
Section	Test Item	Limit
15.247(a)(2)	6 dB Bandwidth	Minimum 500 kHz
	99% Emission Bandwidth	-

### 5.2 TEST PROCEDURE

- The EUT was directly connected to the spectrum analyzer and antenna output port as show in the block diagram below.
- Spectrum Setting:
  - For 6 dB Bandwidth : RBW= 100 kHz, VBW=300 kHz, Sweep time = 2.5 ms.
  - For 99% Emission Bandwidth B/G/N-20 Mode: RBW= 300 KHz, VBW=1 MHz, Sweep time = 2.5 ms.
- The bandwidth was performed in accordance with method 11.8.1 of ANSI C63.10-2013.

### 5.3 DEVIATION FROM STANDARD

No deviation.

### 5.4 TEST SETUP

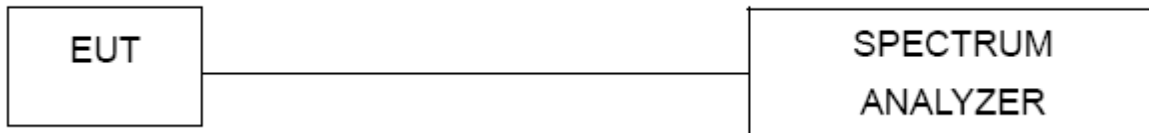

### 5.5 EUT OPERATION CONDITIONS

The EUT was programmed to be in continuously transmitting mode.

### 5.6 TEST RESULTS

Please refer to the APPENDIX E.

## 6. MAXIMUM OUTPUT POWER TEST

### 6.1 LIMIT

FCC Part15, Subpart C (15.247)		
Section	Test Item	Limit
15.247(b)(3)	Maximum Output Power	1 Watt or 30dBm

### 6.2 TEST PROCEDURE

- The EUT was directly connected to the power meter and antenna output port as show in the block diagram below.
- The maximum conducted output power was performed in accordance with method 11.9.2.3.1 of ANSI C63.10-2013.

### 6.3 DEVIATION FROM STANDARD

No deviation.

### 6.4 TEST SETUP

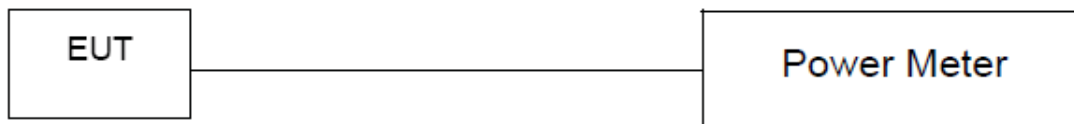

### 6.5 EUT OPERATION CONDITIONS

The EUT was programmed to be in continuously transmitting mode.

### 6.6 TEST RESULTS

Please refer to the APPENDIX F.

## 7. CONDUCTED SPURIOUS EMISSIONS

### 7.1 LIMIT

In any 100 kHz bandwidth outside the frequency band in which the spread spectrum or digitally modulated intentional radiator is operating, the radio frequency power that is produced by the intentional radiator shall be at least 20 dB below that in the 100 kHz bandwidth within the band that contains the highest level of the desired power, based on either an RF conducted or a radiated measurement, provided the transmitter demonstrates compliance with the peak Output Power limits. If the transmitter complies with the Output Power limits based on the use of RMS averaging over a time interval, as permitted under paragraph (b)(3) of this section, the attenuation required under this paragraph shall be 30 dB instead of 20 dB. Attenuation below the general limits specified in Section 15.209(a) is not required.

### 7.2 TEST PROCEDURE

- a. The EUT was directly connected to the spectrum analyzer and antenna output port as show in the block diagram below.
- b. Spectrum Setting: RBW= 100 kHz, VBW=300 kHz, Sweep time = Auto.

### 7.3 DEVIATION FROM STANDARD

No deviation.

### 7.4 TEST SETUP



### 7.5 EUT OPERATION CONDITIONS

The EUT was programmed to be in continuously transmitting mode.

### 7.6 TEST RESULTS

Please refer to the APPENDIX G.

## 8. POWER SPECTRAL DENSITY TEST

### 8.1 LIMIT

FCC Part15, Subpart C (15.247)		
Section	Test Item	Limit
15.247(e)	Power Spectral Density	8 dBm (in any 3 kHz)

### 8.2 TEST PROCEDURE

- The EUT was directly connected to the spectrum analyzer and antenna output port as show in the block diagram below.
- Spectrum Setting: RBW=3 kHz, VBW=10 kHz, Sweep time = Auto.
- The Power Spectral Density was performed in accordance with method 11.10.2 of ANSI C63.10-2013.

### 8.3 DEVIATION FROM STANDARD

No deviation.

### 8.4 TEST SETUP



### 8.5 EUT OPERATION CONDITIONS

The EUT was programmed to be in continuously transmitting mode.

### 8.6 TEST RESULTS

Please refer to the APPENDIX H.



## 9. MEASUREMENT INSTRUMENTS LIST

AC Power Line Conducted Emissions					
Item	Kind of Equipment	Manufacturer	Type No.	Serial No.	Calibrated until
1	EMI Test Receiver	R&S	ESCI	100382	Mar. 10, 2020
2	LISN	EMCO	3816/2	52765	Mar. 10, 2020
3	TWO-LINE V-NETWORK	R&S	ENV216	101447	May. 19, 2020
4	50Ω Terminator	SHX	TF5-3	15041305	Mar. 10, 2020
5	Measurement Software	Farad	EZ-EMC Ver.NB-03A1-01	N/A	N/A
6	Cable	N/A	RG223	12m	Mar. 12, 2020

Radiated Emissions - 9 kHz to 30 MHz					
Item	Kind of Equipment	Manufacturer	Type No.	Serial No.	Calibrated until
1	Loop Antenna	EM	EM-6876-1	230	Jan. 15, 2020
2	Cable	N/A	RG 213/U	C-102	May 31, 2020
3	EMI Test Receiver	R&S	ESCI	100895	Mar. 10, 2020
4	Measurement Software	Farad	EZ-EMC Ver.NB-03A1-01	N/A	N/A

Radiated Emissions - 30 MHz to 1 GHz					
Item	Kind of Equipment	Manufacturer	Type No.	Serial No.	Calibrated until
1	Antenna	Schwarzbeck	VULB9160	9160-3232	Mar. 09, 2020
2*	Amplifier*	HP	8447D	2944A09673	Aug. 11, 2021
3	Receiver	Agilent	N9038A	MY52130039	Aug. 03, 2020
4	Cable	emci	LMR-400(30MHz-1 GHz)(8m+5m)	N/A	May 24, 2020
5	Controller	CT	SC100	N/A	N/A
6	Controller	MF	MF-7802	MF780208416	N/A
7	Measurement Software	Farad	EZ-EMC Ver.NB-03A1-01	N/A	N/A

Radiated Emissions - Above 1 GHz					
Item	Kind of Equipment	Manufacturer	Type No.	Serial No.	Calibrated until
1	Double Ridged Guide Antenna	ETS	3115	75789	Mar. 09, 2020
2	Broad-Band Horn Antenna	Schwarzbeck	BBHA 9170	9170319	Jun. 23, 2020
3	Amplifier	Agilent	8449B	3008A02333	Mar. 10, 2020
4	Microwave Preamplifier With Adaptor	EMC INSTRUMENT	EMC2654045	980039 & HA01	Mar. 10, 2020
5	Receiver	Agilent	N9038A	MY52130039	Aug. 03, 2020
6	Controller	CT	SC100	N/A	N/A
7	Controller	MF	MF-7802	MF780208416	N/A
8	Cable	mitron	B10-01-01-12M	18072744	Jun. 29, 2020
9	Measurement Software	Farad	EZ-EMC Ver.NB-03A1-01	N/A	N/A

Bandwidth & Antenna Conducted Spurious Emissions & Power Spectral Density					
Item	Kind of Equipment	Manufacturer	Type No.	Serial No.	Calibrated until
1	Spectrum Analyzer	R&S	FSP40	100185	Aug. 03, 2020

Maximum Output Power					
Item	Kind of Equipment	Manufacturer	Type No.	Serial No.	Calibrated until
1	Peak Power Analyzer	Keysight	8990B	MY51000506	Aug. 03, 2020
2	Wideband power sensor	Keysight	N1923A	MY58310004	Aug. 03, 2020

Remark: "N/A" denotes no model name, serial no. or calibration specified.

"\*\*" calibration period of equipment list is three year.

Except \* item, all calibration period of equipment list is one year.

**10. EUT TEST PHOTO****AC Power Line Conducted Emissions Test Photos**

**Radiated Emissions Test Photos****9 kHz to 30 MHz**

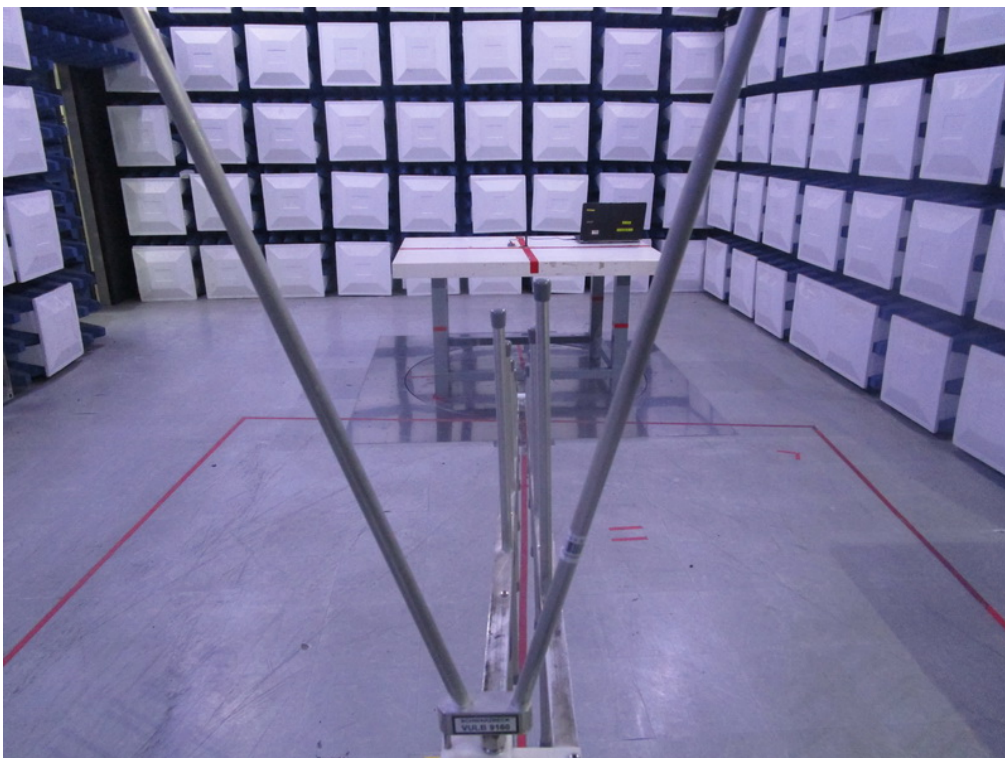
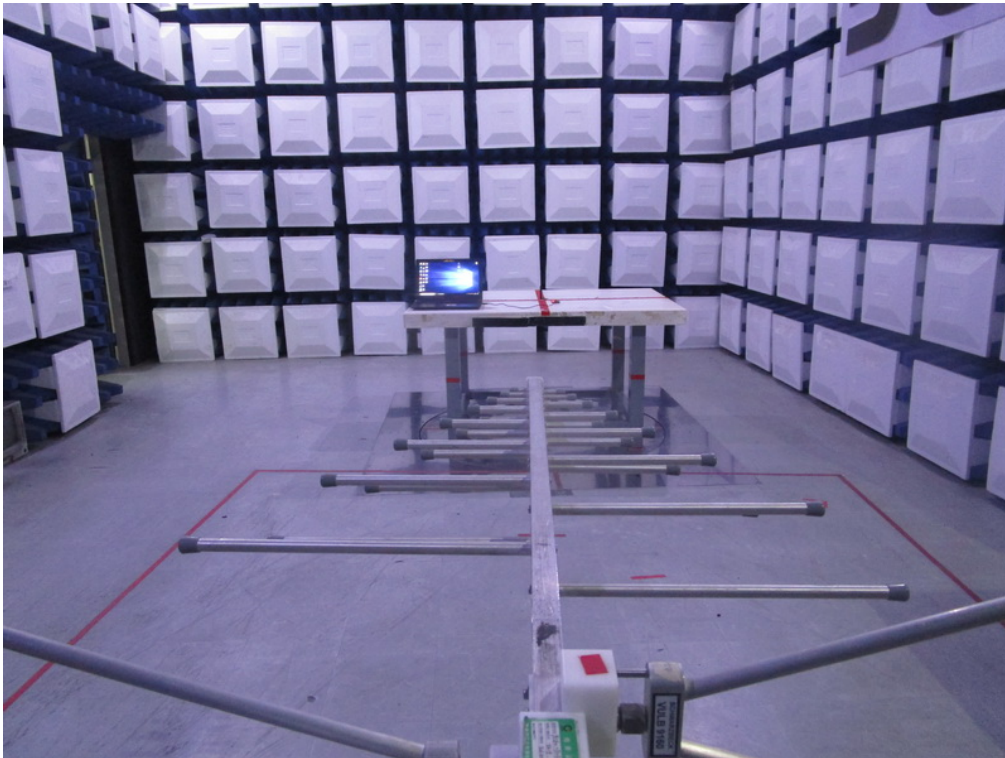

**Radiated Emissions Test Photos****30 MHz to 1 GHz**

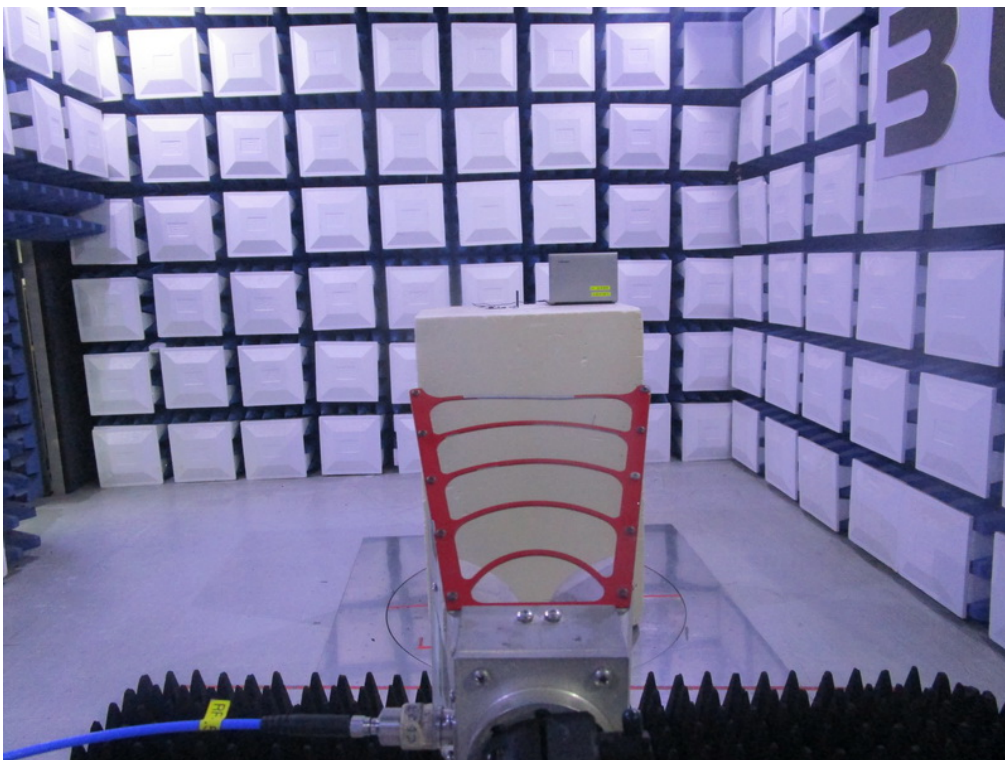
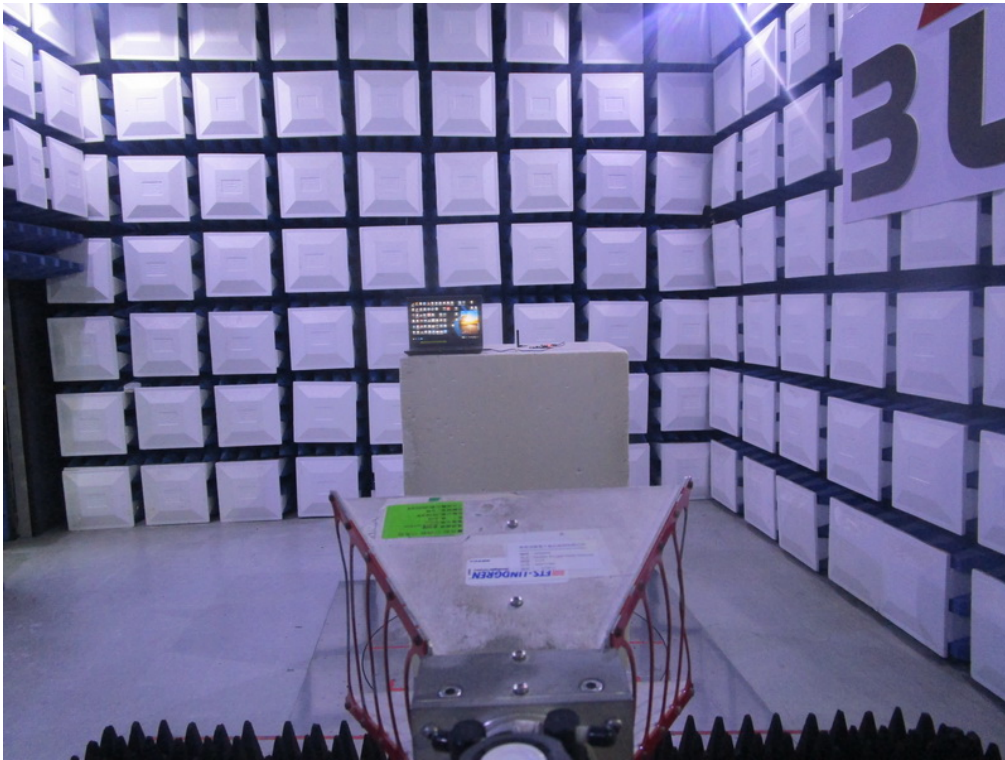
**Radiated Emissions Test Photos****Above 1 GHz**

## **APPENDIX A - AC POWER LINE CONDUCTED EMISSIONS**

Test Mode: TX B Mode Channel 11 (USB Support)

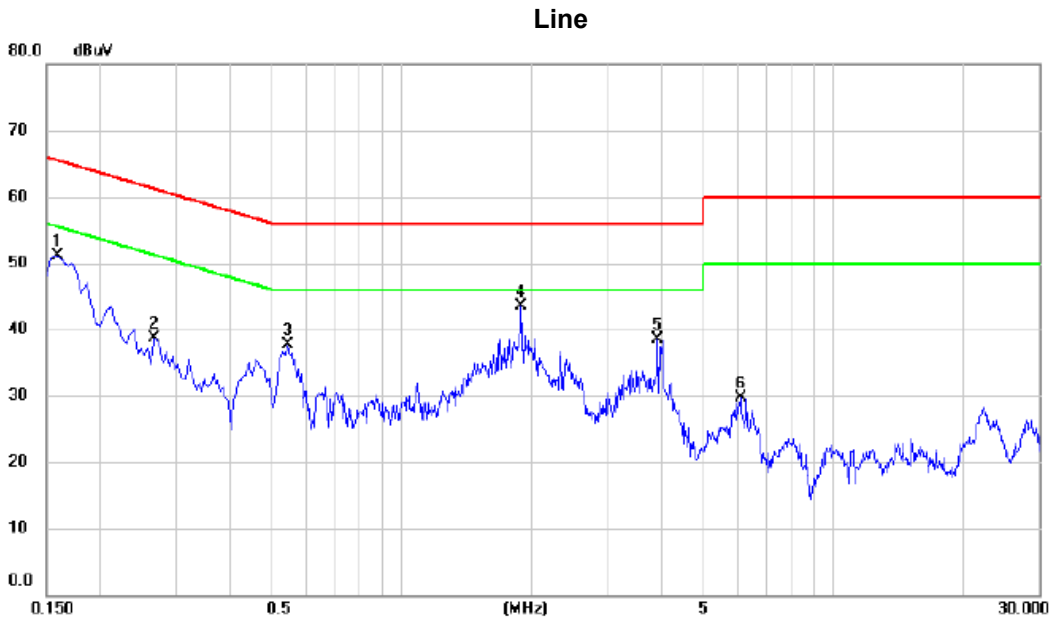

No.	Mk.	Freq.	Reading Level	Correct Factor	Measurement	Limit	Margin	Detector	Comment
		MHz	dBuV	dB	dBuV	dBuV	dB		
1		0.1590	51.07	0.06	51.13	65.52	-14.39	peak	
2		0.2670	38.63	0.07	38.70	61.21	-22.51	peak	
3		0.5460	37.54	0.10	37.64	56.00	-18.36	peak	
4	*	1.8915	43.40	0.20	43.60	56.00	-12.40	peak	
5		3.9075	38.20	0.30	38.50	56.00	-17.50	peak	
6		6.0810	29.25	0.38	29.63	60.00	-30.37	peak	

**REMARKS:**

- (1) Measurement Value = Reading Level + Correct Factor.
- (2) Margin Level = Measurement Value - Limit Value.



Test Mode: TX B Mode Channel 11 (USB Support)

### Neutral

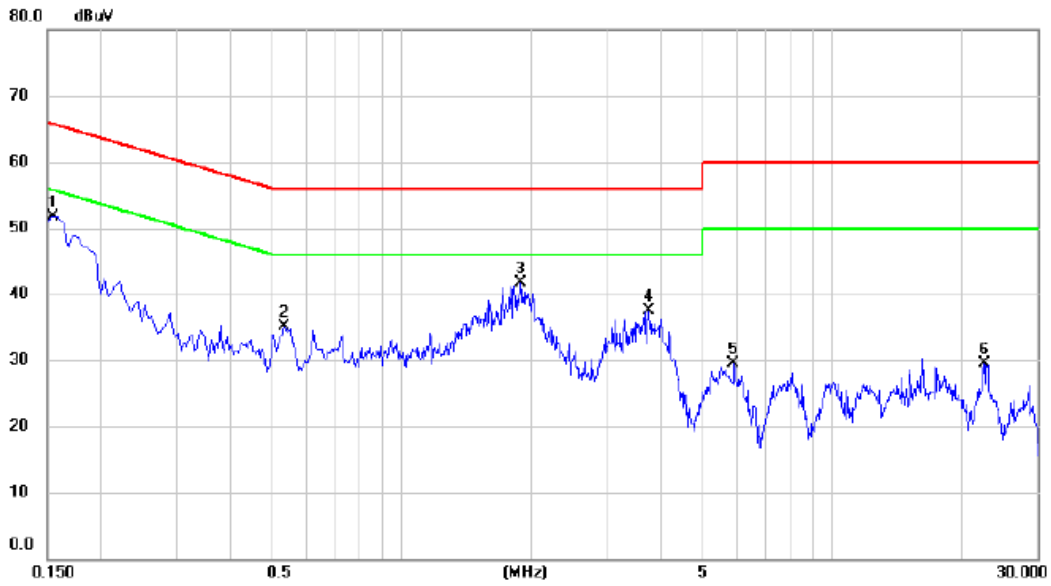

No.	Mk.	Freq. MHz	Reading Level dBuV	Correct Factor dB	Measure- ment dBuV	Limit dBuV	Margin dB	Detector	Comment
1	*	0.1545	51.72	0.06	51.78	65.75	-13.97	peak	
2		0.5325	35.09	0.10	35.19	56.00	-20.81	peak	
3		1.8870	41.54	0.20	41.74	56.00	-14.26	peak	
4		3.7500	37.30	0.29	37.59	56.00	-18.41	peak	
5		5.9055	29.07	0.37	29.44	60.00	-30.56	peak	
6		22.5195	28.76	0.75	29.51	60.00	-30.49	peak	

**REMARKS:**

- (1) Measurement Value = Reading Level + Correct Factor.
- (2) Margin Level = Measurement Value - Limit Value.

## **APPENDIX B - RADIATED EMISSION - 9 KHZ TO 30 MHZ**

Test Mode: TX B Mode Channel 11

Ant 0°

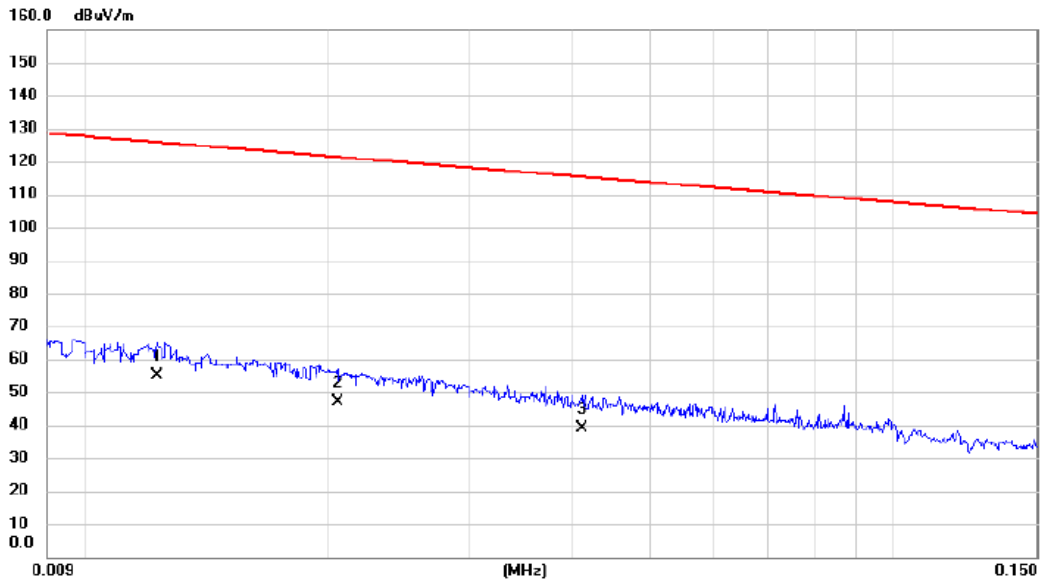

No.	Mk.	Freq.	Reading Level	Correct Factor	Measurement	Limit	Margin	Detector	Comment
		MHz	dBuV	dB	dBuV/m	dBuV/m	dB		
1	*	0.012	38.92	16.13	55.05	125.81	-70.76	AVG	
2		0.021	32.99	13.82	46.81	121.33	-74.52	AVG	
3		0.041	25.14	13.90	39.04	115.31	-76.27	AVG	

REMARKS:

- (1) Measurement Value = Reading Level + Correct Factor.
- (2) Margin Level = Measurement Value - Limit Value.

Test Mode: TX B Mode Channel 11

Ant 0°

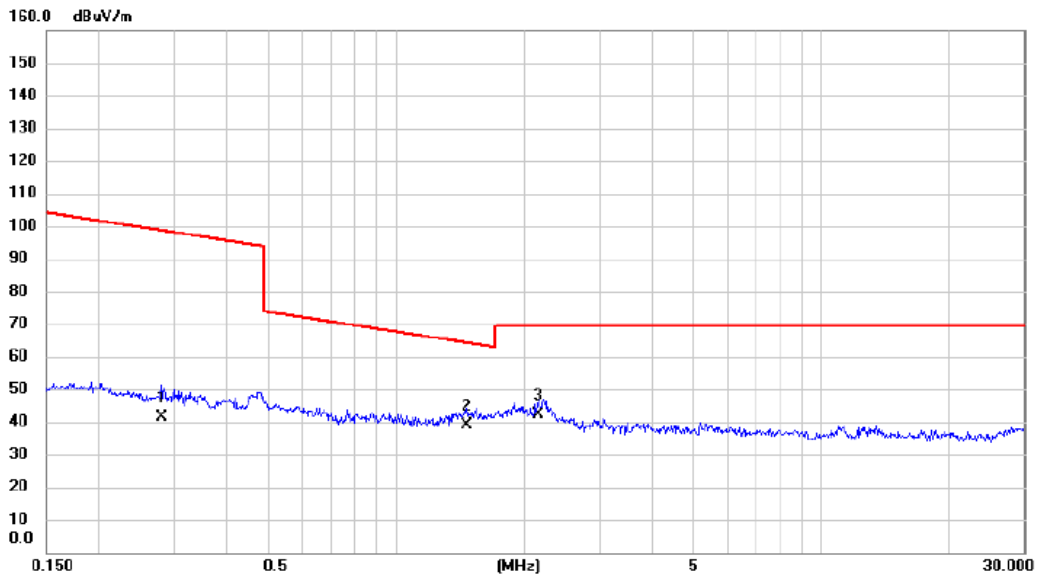

No.	Mk.	Freq.	Reading Level	Correct Factor	Measurement	Limit	Margin	Detector	Comment
		MHz	dBuV	dB	dBuV/m	dBuV/m	dB		
1		0.280	27.75	13.59	41.34	98.66	-57.32	AVG	
2	*	1.464	26.88	12.19	39.07	64.29	-25.22	QP	
3		2.155	30.30	11.73	42.03	69.54	-27.51	QP	

REMARKS:

- (1) Measurement Value = Reading Level + Correct Factor.
- (2) Margin Level = Measurement Value - Limit Value.

Test Mode: TX B Mode Channel 11

**Ant 90°**

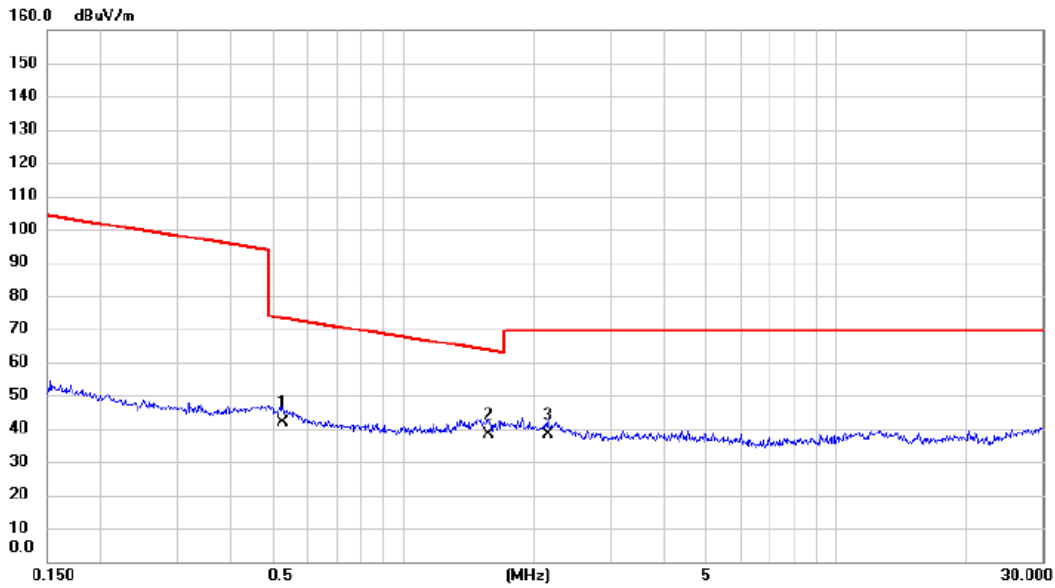

No.	Mk.	Freq.	Reading Level	Correct Factor	Measurement	Limit	Margin	Detector	Comment
		MHz	dBuV	dB	dBuV/m	dBuV/m	dB		
1		0.526	28.79	13.01	41.80	73.18	-31.38	QP	
2	*	1.568	25.90	12.11	38.01	63.70	-25.69	QP	
3		2.155	26.50	11.73	38.23	69.54	-31.31	QP	

**REMARKS:**

- (1) Measurement Value = Reading Level + Correct Factor.
- (2) Margin Level = Measurement Value - Limit Value.

Test Mode: TX B Mode Channel 11

**Ant 90°**

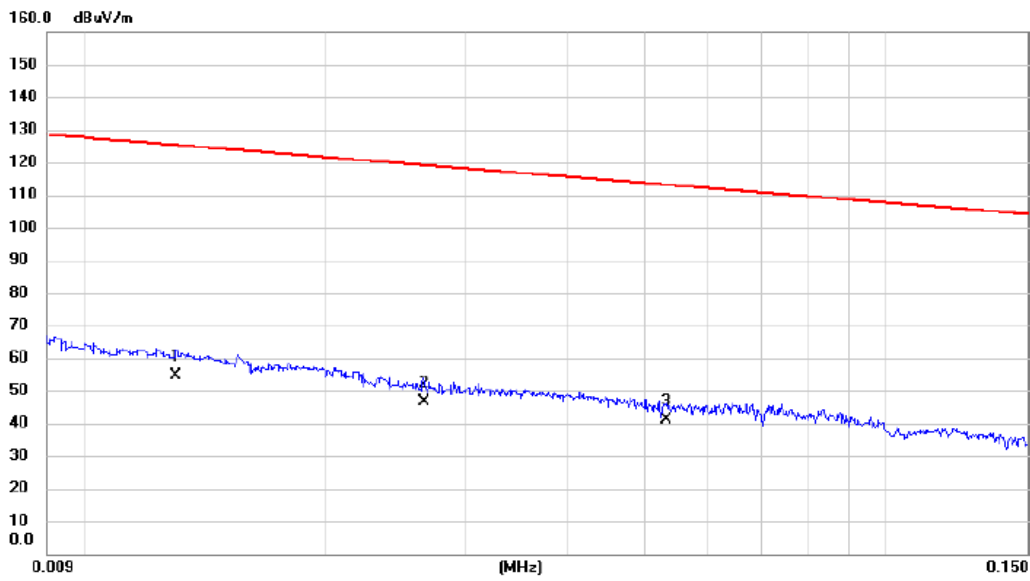

No.	Mk.	Freq.	Reading Level	Correct Factor	Measurement	Limit	Margin	Detector	Comment
		MHz	dBuV	dB	dBuV/m	dBuV/m	dB		
1	*	0.013	38.66	15.92	54.58	125.33	-70.75	AVG	
2		0.027	32.83	13.84	46.67	119.11	-72.44	AVG	
3		0.053	27.30	13.88	41.18	113.10	-71.92	AVG	

**REMARKS:**

- (1) Measurement Value = Reading Level + Correct Factor.
- (2) Margin Level = Measurement Value - Limit Value.

**APPENDIX C - RADIATED EMISSION - 30 MHZ TO 1000 MHZ**

Test Mode: TX B Mode Channel 11

### Vertical

80 dBuV/m

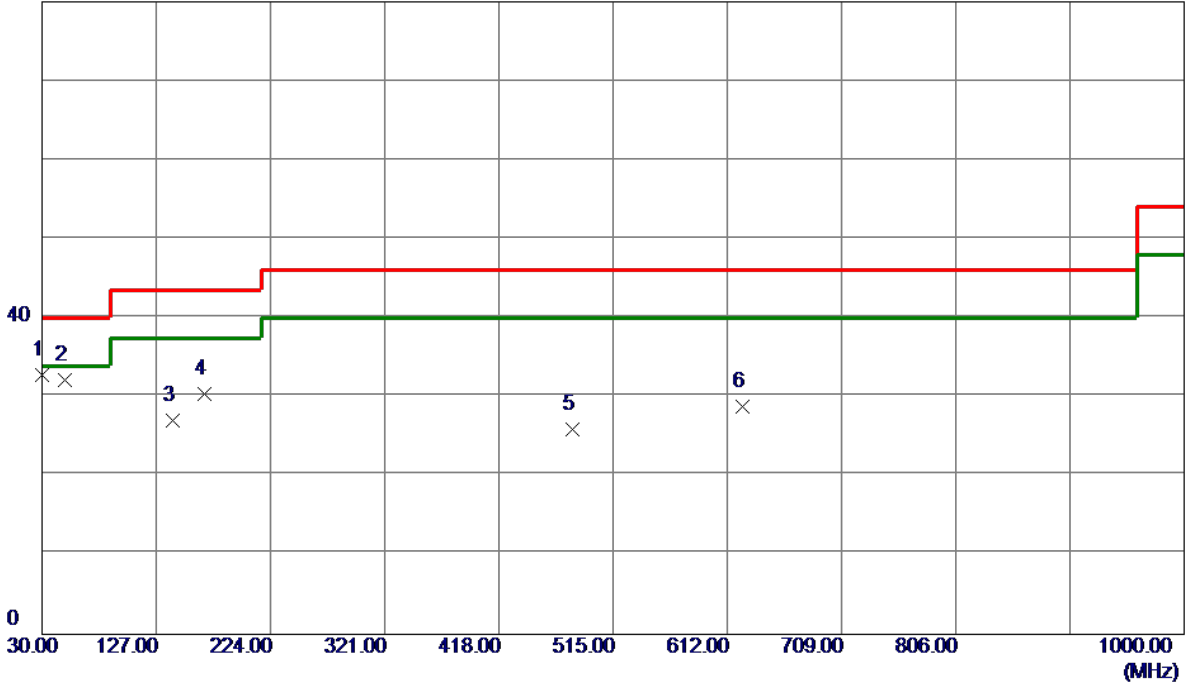

No.	Freq. MHz	Reading Level dBuV/m	Correct Factor dB	Measure ment dBuV/m	Limit dBuV/m	Margin dB	Detector	Comment
1 *	30.0000	47.88	-15.02	32.86	40.00	-7.14	Peak	
2	49.4000	46.14	-13.98	32.16	40.00	-7.84	Peak	
3	140.5800	40.00	-12.90	27.10	43.50	-16.40	Peak	
4	167.7400	42.59	-12.17	30.42	43.50	-13.08	Peak	
5	480.0800	33.81	-7.91	25.90	46.00	-20.10	Peak	
6	624.6100	34.00	-5.27	28.73	46.00	-17.27	Peak	

**REMARKS:**

- (1) Measurement Value = Reading Level + Correct Factor.
- (2) Margin Level = Measurement Value - Limit Value.



Test Mode: TX B Mode Channel 11

### Horizontal

80 dBuV/m

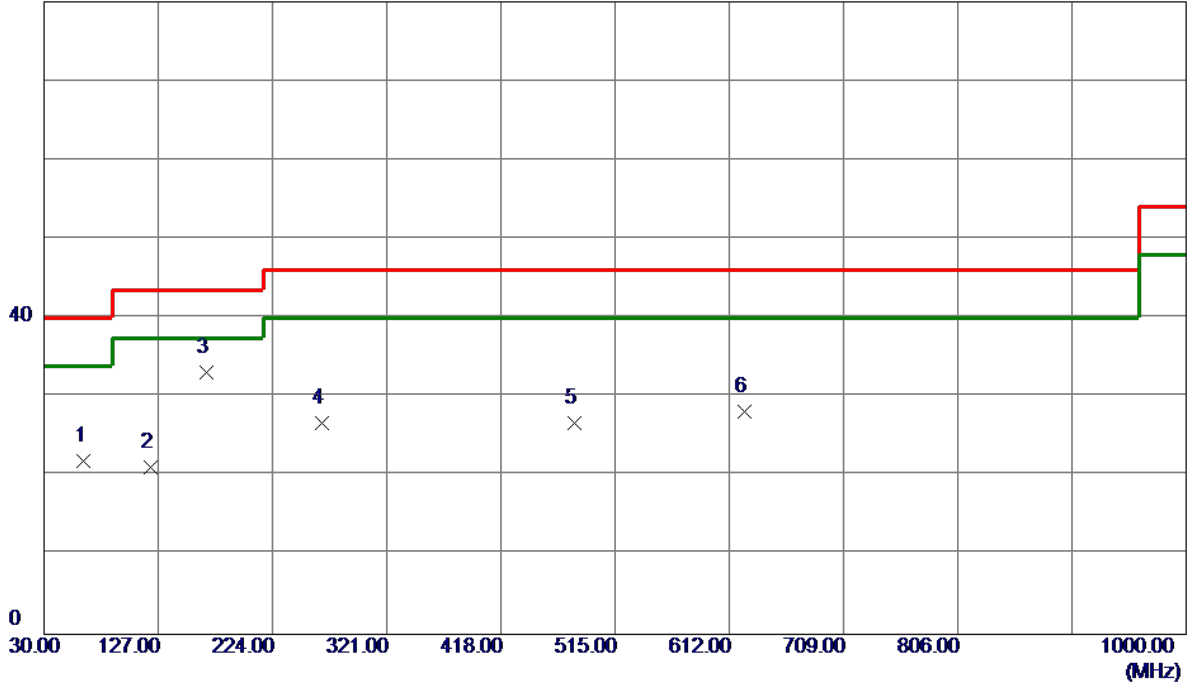

No.	Freq. MHz	Reading Level dBuV/m	Correct Factor dB	Measure ment dBuV/m	Limit dBuV/m	Margin dB	Detector	Comment
1	63.9500	37.01	-15.12	21.89	40.00	-18.11	Peak	
2	120.2100	34.15	-13.10	21.05	43.50	-22.45	Peak	
3 *	167.7400	45.27	-12.17	33.10	43.50	-10.40	Peak	
4	265.7100	39.68	-12.97	26.71	46.00	-19.29	Peak	
5	480.0800	34.62	-7.91	26.71	46.00	-19.29	Peak	
6	624.6100	33.49	-5.27	28.22	46.00	-17.78	Peak	

**REMARKS:**

(1) Measurement Value = Reading Level + Correct Factor.

(2) Margin Level = Measurement Value - Limit Value.

## **APPENDIX D - RADIATED EMISSION- ABOVE 1000 MHZ**

Test Mode: TX B Mode 2412 MHz

### Vertical

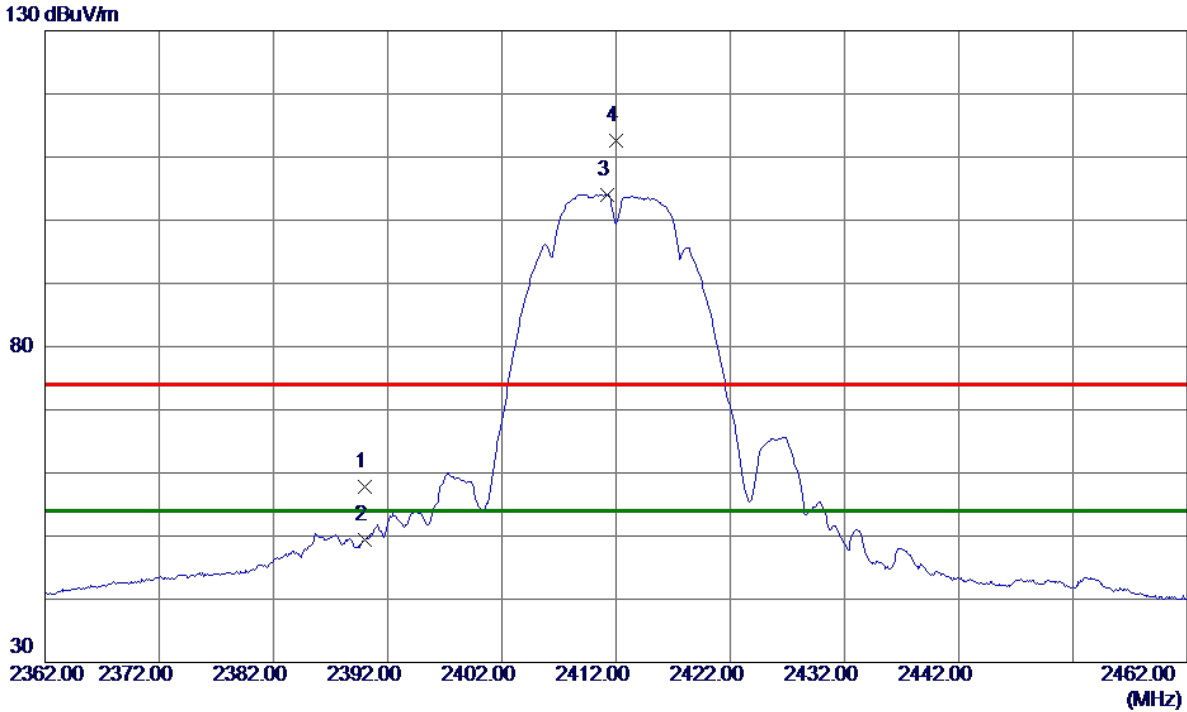

No.	Freq. MHz	Reading Level dBuV/m	Correct Factor dB	Measure ment dBuV/m	Limit dBuV/m	Margin dB	Detector	Comment
1	2390.0000	51.35	6.53	57.88	74.00	-16.12	Peak	
2	2390.0000	42.96	6.53	49.49	54.00	-4.51	AVG	
3 *	2411.2000	97.56	6.51	104.07	54.00	50.07	AVG	No Limit
4	2412.0000	106.18	6.51	112.69	74.00	38.69	Peak	No Limit

**REMARKS:**

- (1) Measurement Value = Reading Level + Correct Factor.
- (2) Margin Level = Measurement Value - Limit Value.

Test Mode: TX B Mode 2412 MHz

### Vertical

80 dBuV/m

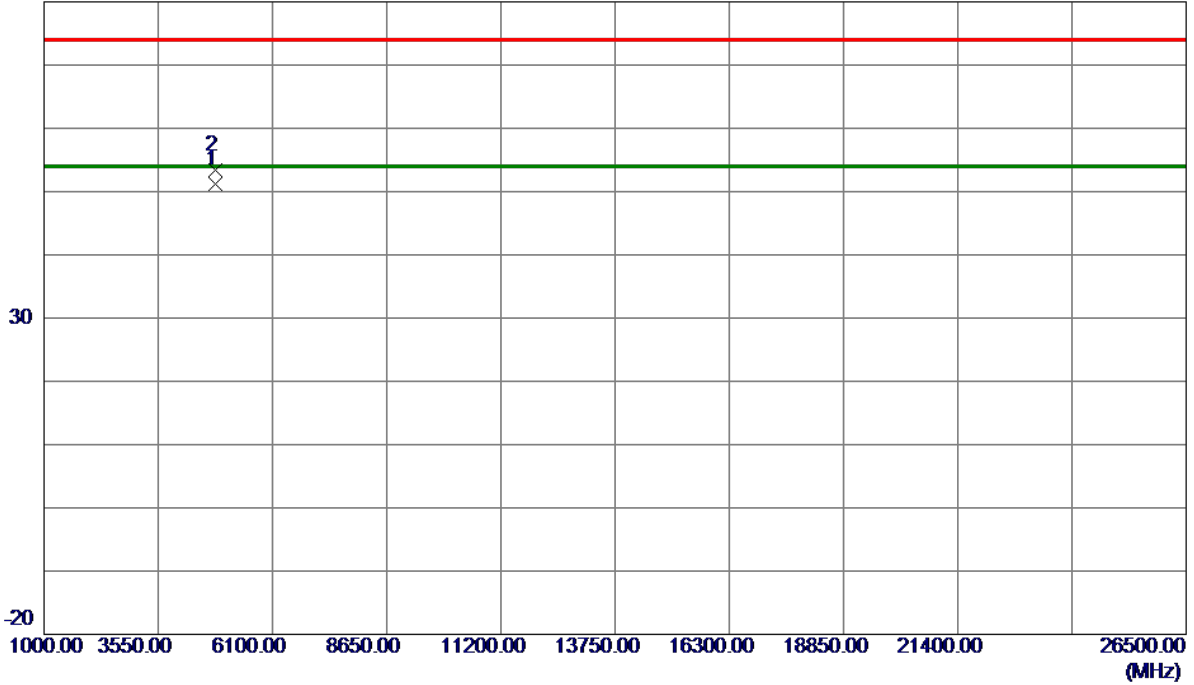

No.	Freq. MHz	Reading Level dBuV/m	Correct Factor dB	Measure ment dBuV/m	Limit dBuV/m	Margin dB	Detector	Comment
1 *	4823.9950	47.78	3.43	51.21	54.00	-2.79	AVG	
2	4824.0200	49.91	3.43	53.34	74.00	-20.66	Peak	

**REMARKS:**

- (1) Measurement Value = Reading Level + Correct Factor.
- (2) Margin Level = Measurement Value - Limit Value.

Test Mode: TX B Mode 2412 MHz

### Horizontal

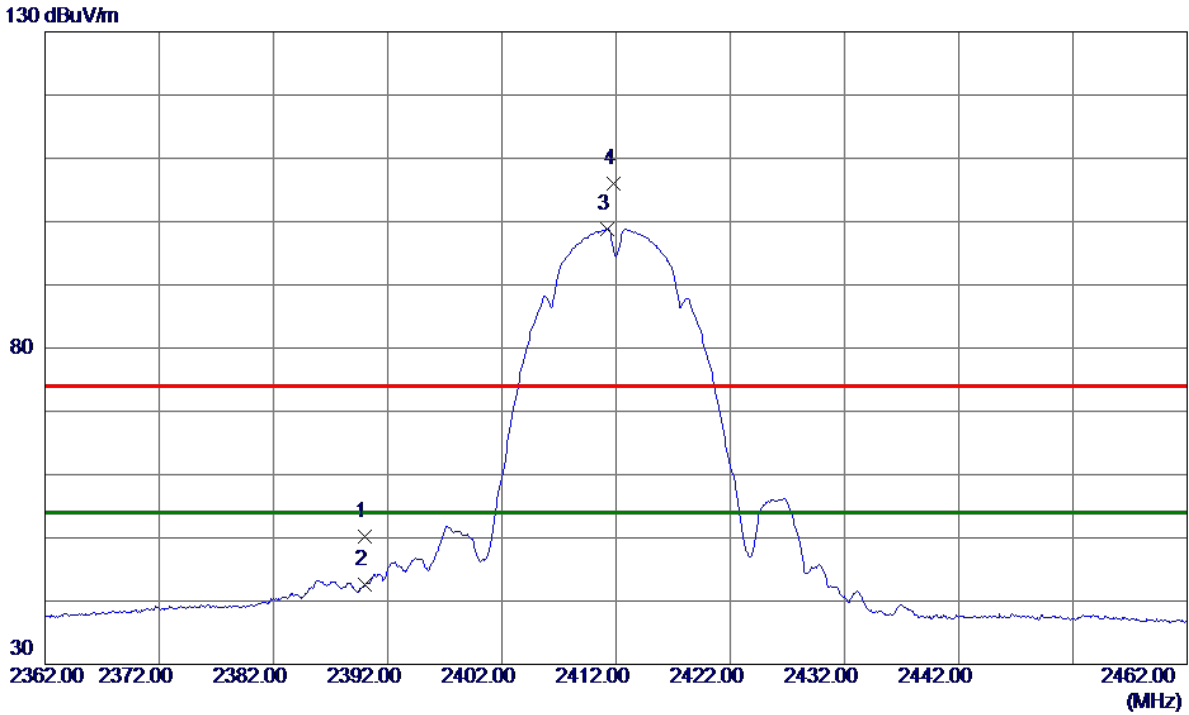

No.	Freq. MHz	Reading Level dBuV/m	Correct Factor dB	Measure ment dBuV/m	Limit dBuV/m	Margin dB	Detector	Comment
1	2390.0000	43.74	6.53	50.27	74.00	-23.73	Peak	
2	2390.0000	36.07	6.53	42.60	54.00	-11.40	AVG	
3 *	2411.2000	92.35	6.51	98.86	54.00	44.86	AVG	No Limit
4	2411.8000	99.56	6.51	106.07	74.00	32.07	Peak	No Limit

**REMARKS:**

- (1) Measurement Value = Reading Level + Correct Factor.
- (2) Margin Level = Measurement Value - Limit Value.

Test Mode: TX B Mode 2412 MHz

### Horizontal

80 dBuV/m

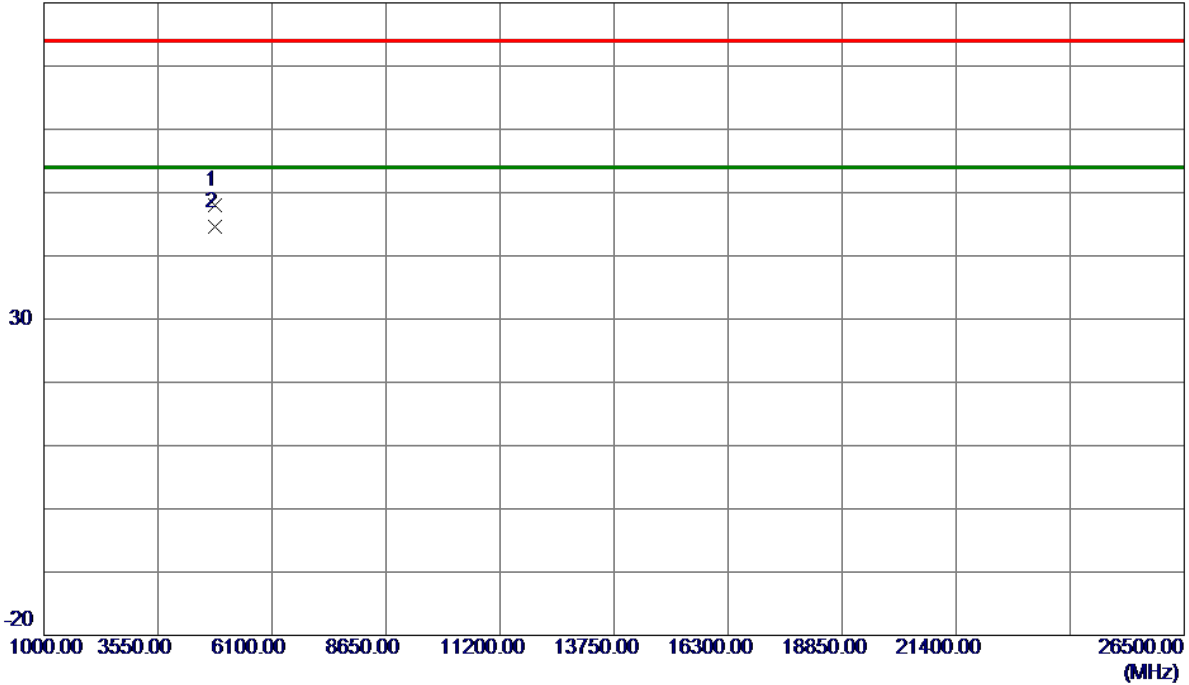

No.	Freq. MHz	Reading Level dBuV/m	Correct Factor dB	Measure ment dBuV/m	Limit dBuV/m	Margin dB	Detector	Comment
1	4823.9450	44.62	3.43	48.05	74.00	-25.95	Peak	
2 *	4823.9900	41.25	3.43	44.68	54.00	-9.32	AVG	

**REMARKS:**

(1) Measurement Value = Reading Level + Correct Factor.

(2) Margin Level = Measurement Value - Limit Value.

Test Mode: TX B Mode 2437 MHz

### Vertical

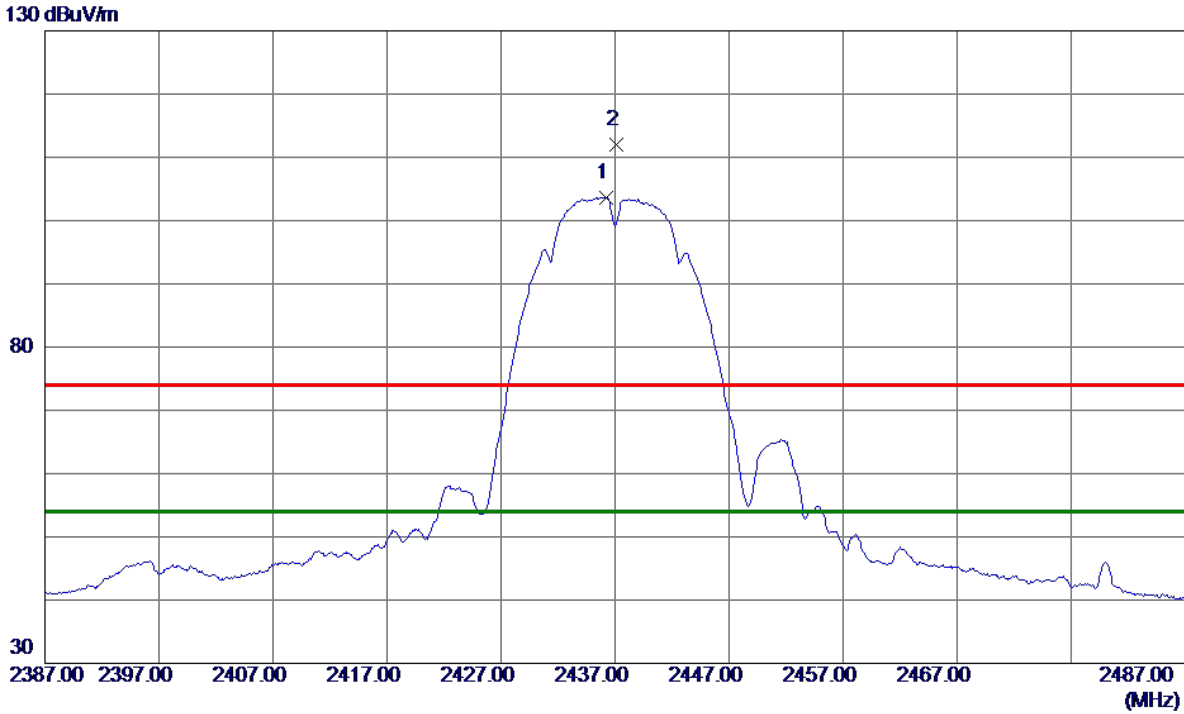

No.	Freq. MHz	Reading Level dBuV/m	Correct Factor dB	Measure ment dBuV/m	Limit dBuV/m	Margin dB	Detector	Comment
1 *	2436.2000	97.21	6.48	103.69	54.00	49.69	AVG	No Limit
2	2437.1000	105.53	6.48	112.01	74.00	38.01	Peak	No Limit

**REMARKS:**

- (1) Measurement Value = Reading Level + Correct Factor.
- (2) Margin Level = Measurement Value - Limit Value.

Test Mode: TX B Mode 2437 MHz

### Vertical

80 dBuV/m

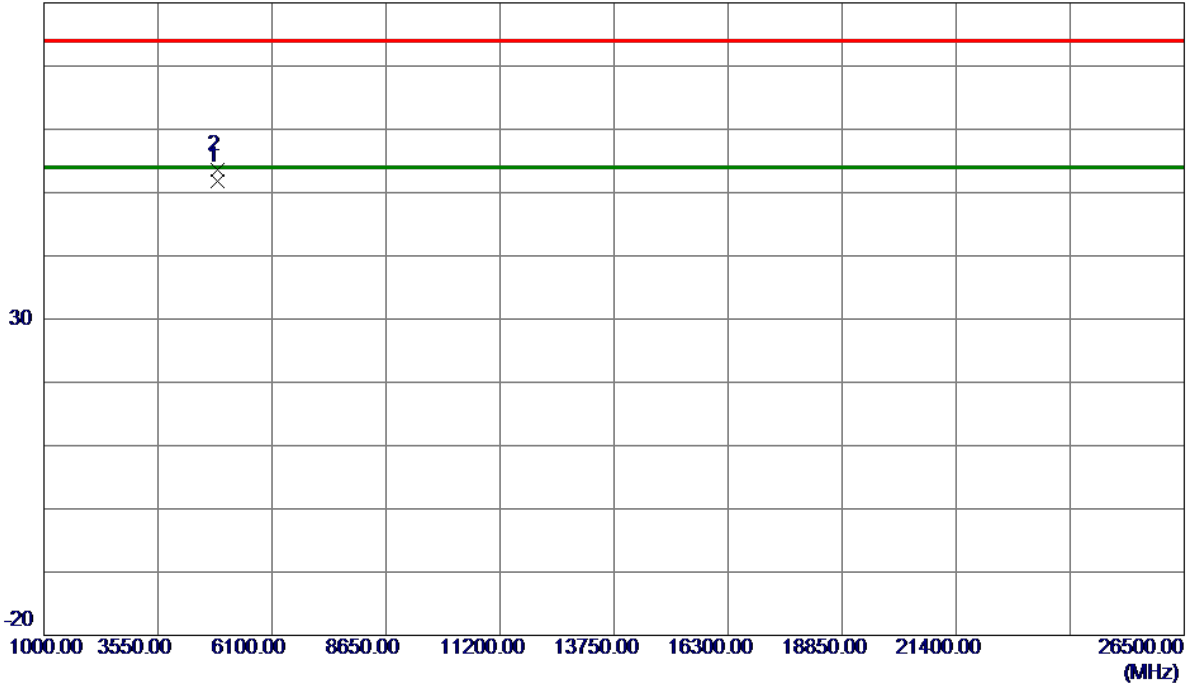

No.	Freq. MHz	Reading Level dBuV/m	Correct Factor dB	Measure ment dBuV/m	Limit dBuV/m	Margin dB	Detector	Comment
1 *	4873.9850	48.25	3.58	51.83	54.00	-2.17	AVG	
2	4874.0950	50.02	3.58	53.60	74.00	-20.40	Peak	

**REMARKS:**

- (1) Measurement Value = Reading Level + Correct Factor.
- (2) Margin Level = Measurement Value - Limit Value.



Test Mode: TX B Mode 2437 MHz

### Horizontal

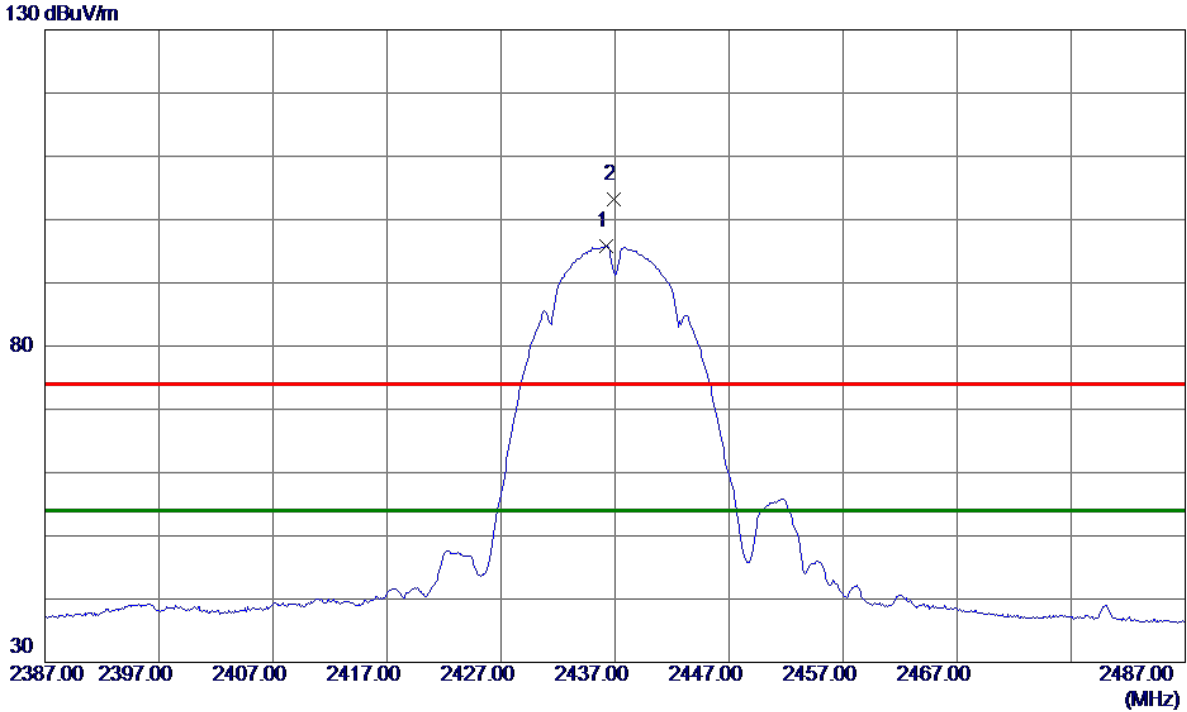

No.	Freq. MHz	Reading Level dBuV/m	Correct Factor dB	Measure ment dBuV/m	Limit dBuV/m	Margin dB	Detector	Comment
1 *	2436.2000	89.32	6.48	95.80	54.00	41.80	AVG	No Limit
2	2436.9000	96.75	6.48	103.23	74.00	29.23	Peak	No Limit

**REMARKS:**

- (1) Measurement Value = Reading Level + Correct Factor.
- (2) Margin Level = Measurement Value - Limit Value.

Test Mode: TX B Mode 2437 MHz

### Horizontal

80 dBuV/m

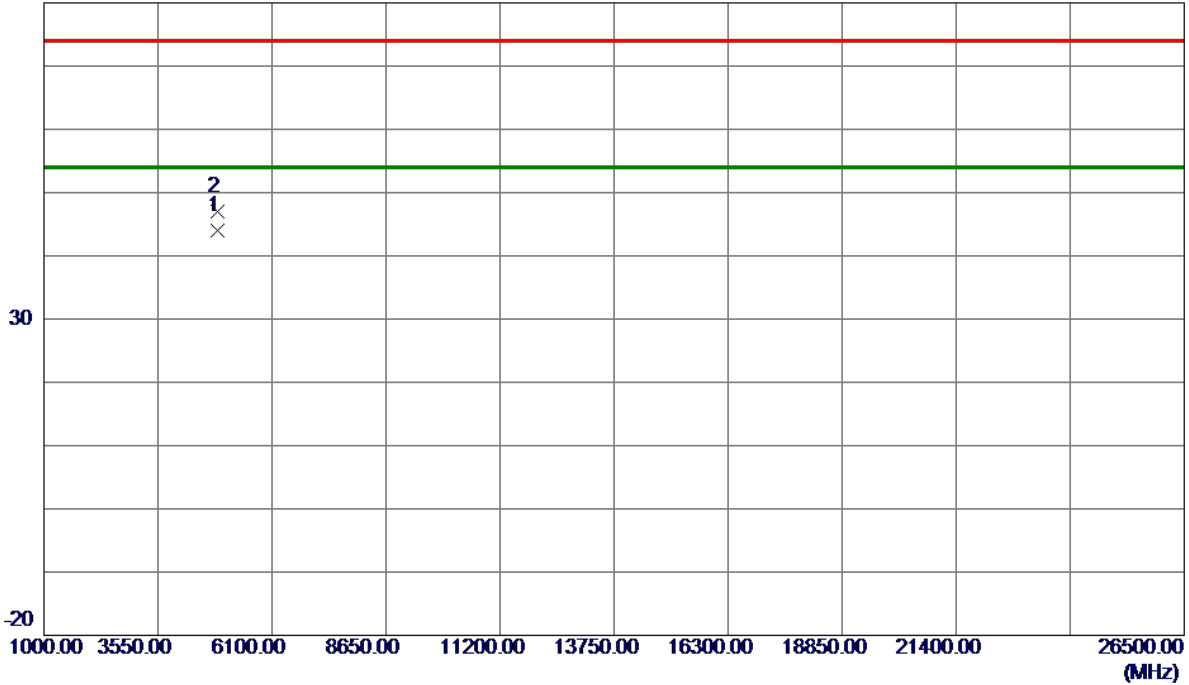

No.	Freq. MHz	Reading Level dBuV/m	Correct Factor dB	Measure ment dBuV/m	Limit dBuV/m	Margin dB	Detector	Comment
1 *	4873.9450	40.41	3.58	43.99	54.00	-10.01	AVG	
2	4874.1349	43.51	3.58	47.09	74.00	-26.91	Peak	

**REMARKS:**

(1) Measurement Value = Reading Level + Correct Factor.

(2) Margin Level = Measurement Value - Limit Value.

Test Mode: TX B Mode 2462 MHz

### Vertical

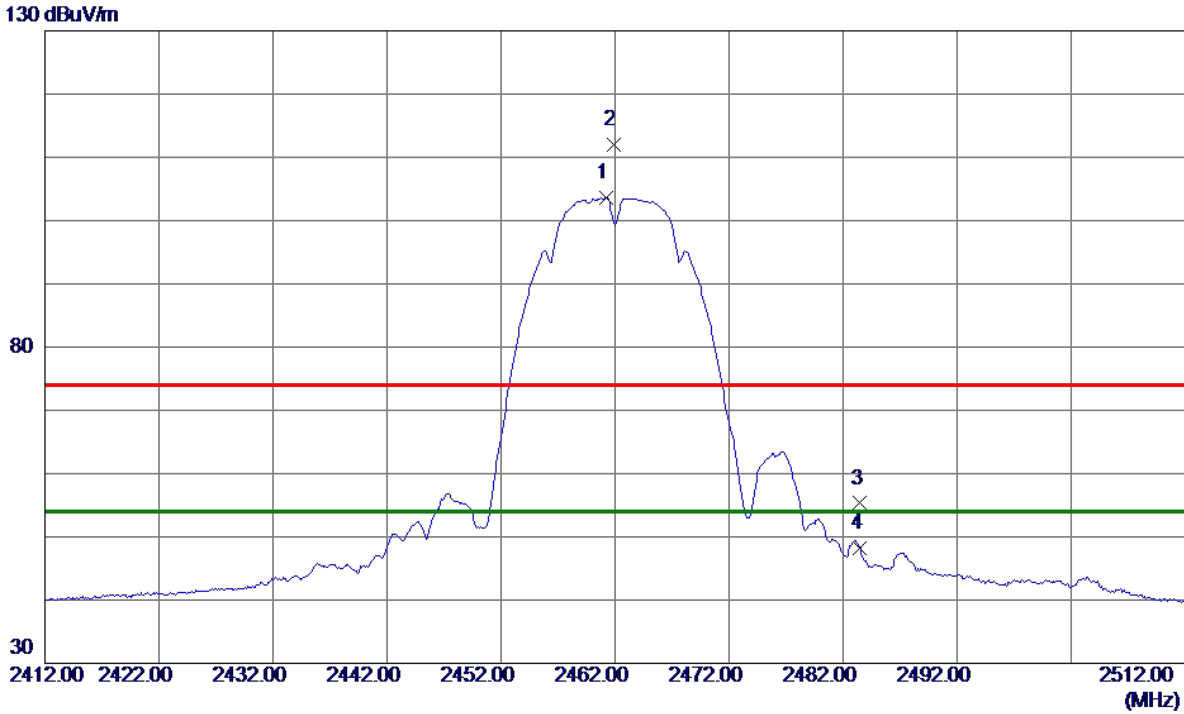

No.	Freq. MHz	Reading Level dBuV/m	Correct Factor dB	Measure ment dBuV/m	Limit dBuV/m	Margin dB	Detector	Comment
1 *	2461.2000	97.14	6.45	103.59	54.00	49.59	AVG	No Limit
2	2461.9000	105.46	6.45	111.91	74.00	37.91	Peak	No Limit
3	2483.5000	48.88	6.42	55.30	74.00	-18.70	Peak	
4	2483.5000	41.72	6.42	48.14	54.00	-5.86	AVG	

**REMARKS:**

- (1) Measurement Value = Reading Level + Correct Factor.
- (2) Margin Level = Measurement Value - Limit Value.

Test Mode: TX B Mode 2462 MHz

### Vertical

80 dBuV/m

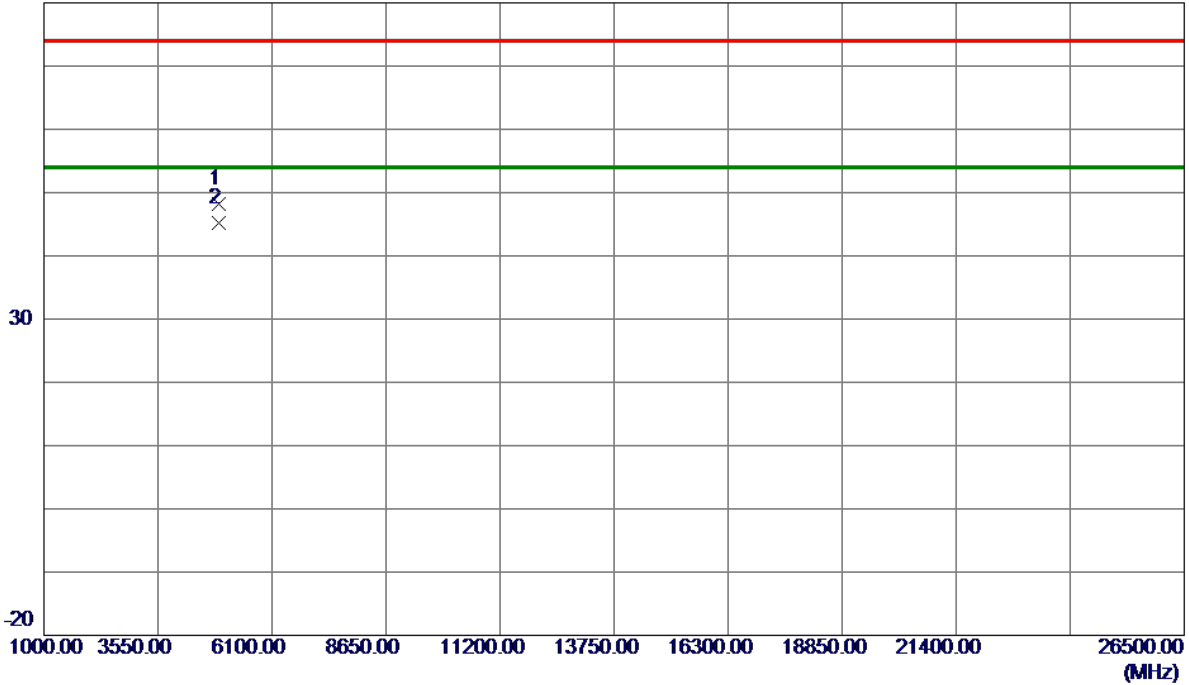

No.	Freq. MHz	Reading Level dBuV/m	Correct Factor dB	Measure ment dBuV/m	Limit dBuV/m	Margin dB	Detector	Comment
1	4923.9100	44.40	3.73	48.13	74.00	-25.87	Peak	
2 *	4923.9800	41.47	3.73	45.20	54.00	-8.80	AVG	

**REMARKS:**

- (1) Measurement Value = Reading Level + Correct Factor.
- (2) Margin Level = Measurement Value - Limit Value.

Test Mode: TX B Mode 2462 MHz

### Horizontal

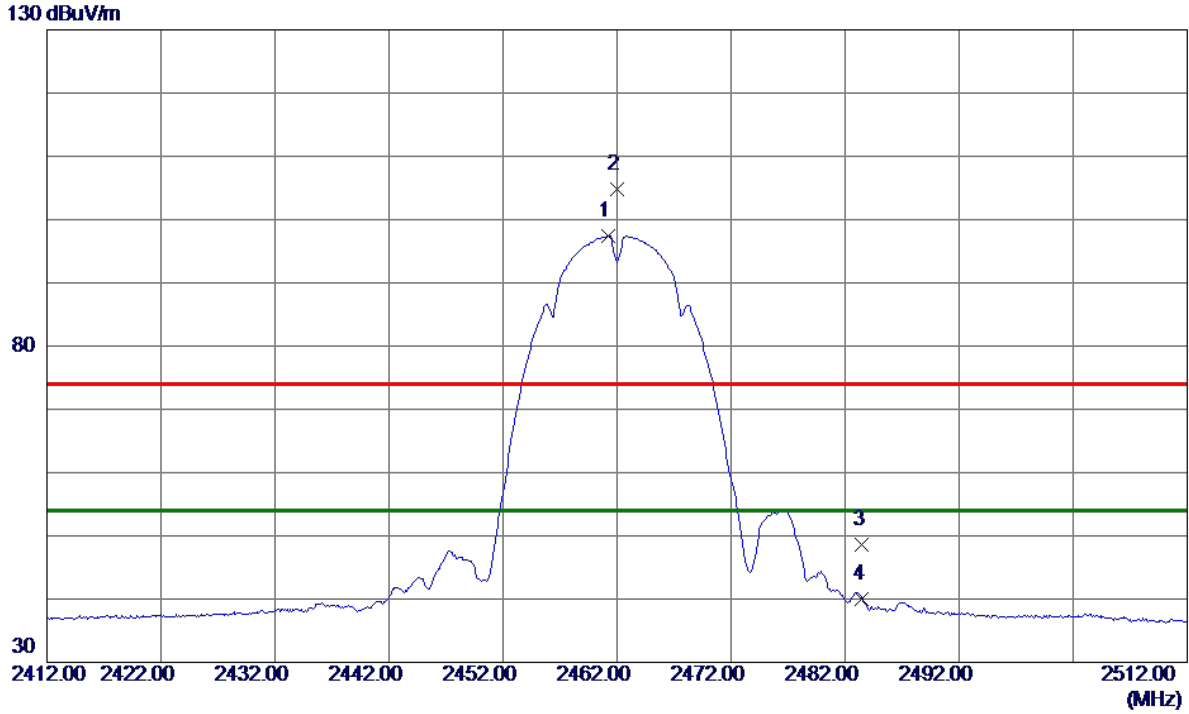

No.	Freq. MHz	Reading Level dBuV/m	Correct Factor dB	Measure ment dBuV/m	Limit dBuV/m	Margin dB	Detector	Comment
1 *	2461.2000	91.03	6.45	97.48	54.00	43.48	AVG	No Limit
2	2462.0000	98.31	6.45	104.76	74.00	30.76	Peak	No Limit
3	2483.5000	42.12	6.42	48.54	74.00	-25.46	Peak	
4	2483.5000	33.60	6.42	40.02	54.00	-13.98	AVG	

**REMARKS:**

- (1) Measurement Value = Reading Level + Correct Factor.
- (2) Margin Level = Measurement Value - Limit Value.

Test Mode: TX B Mode 2462 MHz

### Horizontal

80 dBuV/m

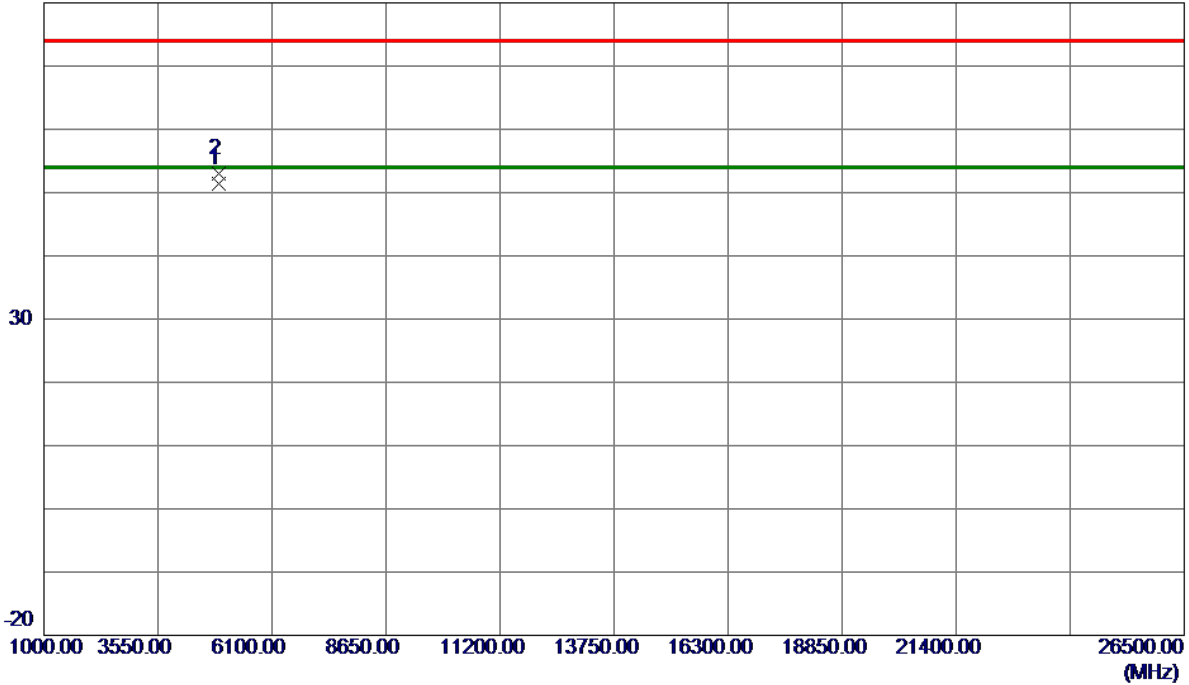

No.	Freq. MHz	Reading Level dBuV/m	Correct Factor dB	Measure ment dBuV/m	Limit dBuV/m	Margin dB	Detector	Comment
1 *	4924.0099	47.58	3.73	51.31	54.00	-2.69	AVG	
2	4924.0150	49.20	3.73	52.93	74.00	-21.07	Peak	

**REMARKS:**

- (1) Measurement Value = Reading Level + Correct Factor.
- (2) Margin Level = Measurement Value - Limit Value.

Test Mode: TX G Mode 2412 MHz

### Vertical

130 dBuV/m

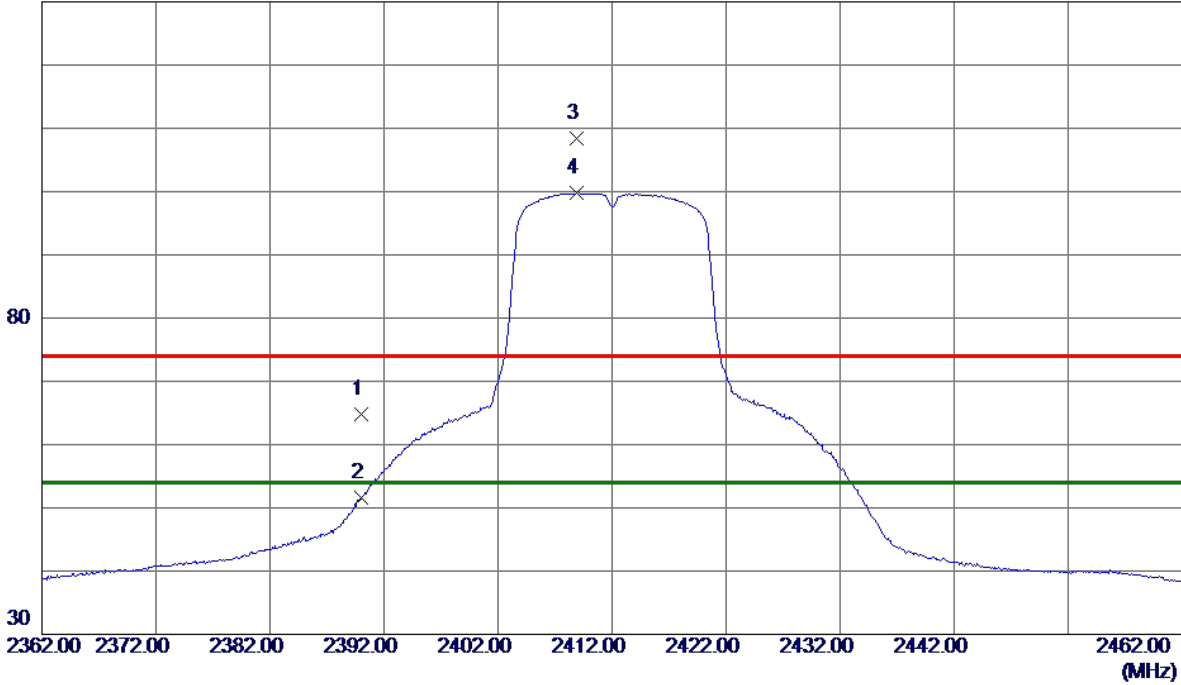

No.	Freq. MHz	Reading Level dBuV/m	Correct Factor dB	Measure ment dBuV/m	Limit dBuV/m	Margin dB	Detector	Comment
1	2390.0000	58.27	6.53	64.80	74.00	-9.20	Peak	
2	2390.0000	45.02	6.53	51.55	54.00	-2.45	AVG	
3	2408.9000	101.90	6.51	108.41	74.00	34.41	Peak	No Limit
4 *	2408.9000	93.21	6.51	99.72	54.00	45.72	AVG	No Limit

**REMARKS:**

- (1) Measurement Value = Reading Level + Correct Factor.
- (2) Margin Level = Measurement Value - Limit Value.

Test Mode: TX G Mode 2412 MHz

### Vertical

80 dBuV/m

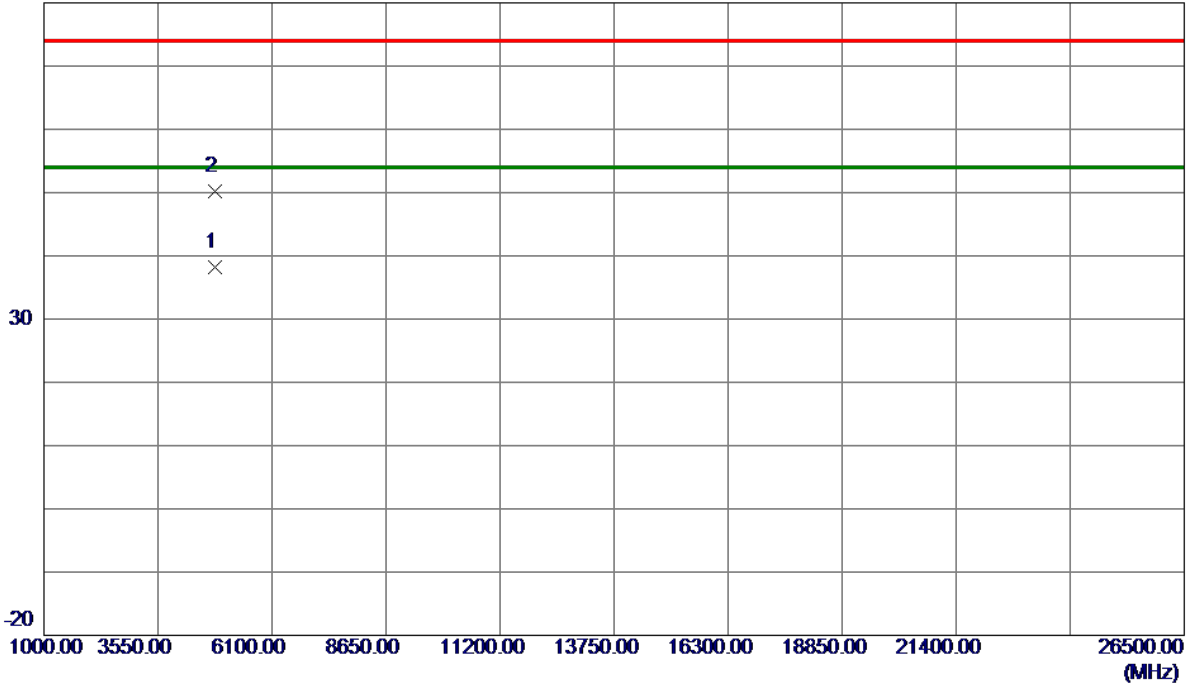

No.	Freq. MHz	Reading Level dBuV/m	Correct Factor dB	Measure ment dBuV/m	Limit dBuV/m	Margin dB	Detector	Comment
1 *	4824.0200	34.78	3.43	38.21	54.00	-15.79	AVG	
2	4824.6950	46.70	3.43	50.13	74.00	-23.87	Peak	

**REMARKS:**

- (1) Measurement Value = Reading Level + Correct Factor.
- (2) Margin Level = Measurement Value - Limit Value.



Test Mode: TX G Mode 2412 MHz

### Horizontal

130 dBuV/m

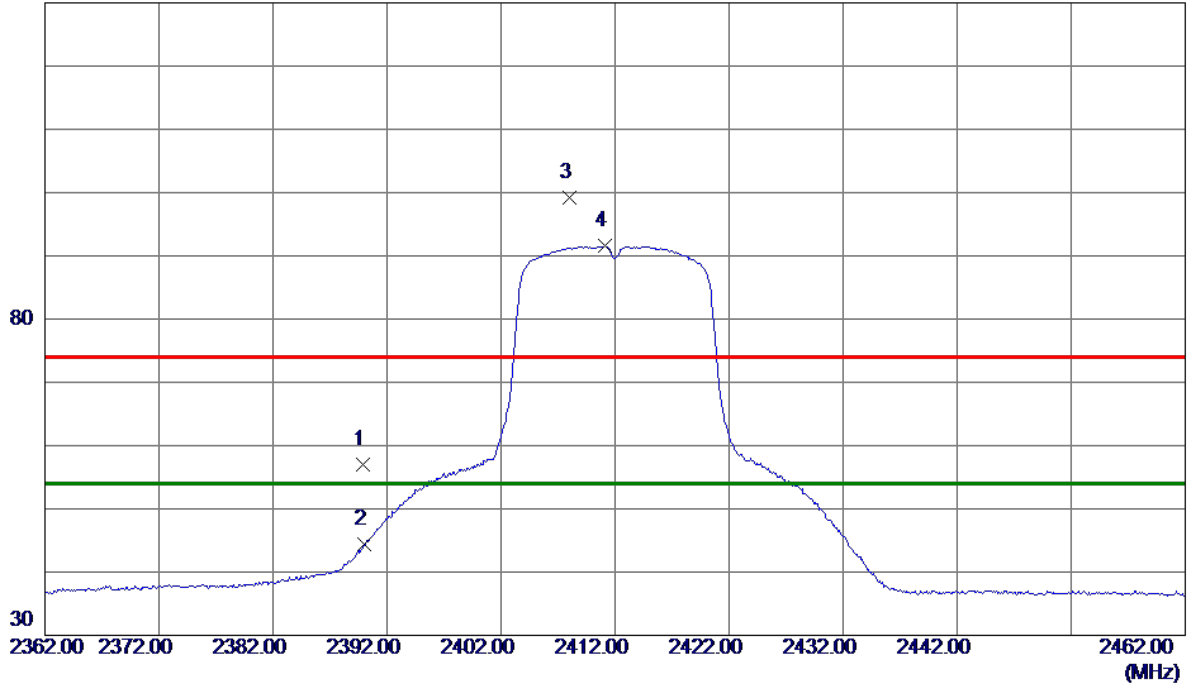

No.	Freq. MHz	Reading Level dBuV/m	Correct Factor dB	Measure ment dBuV/m	Limit dBuV/m	Margin dB	Detector	Comment
1	2389.9000	50.41	6.53	56.94	74.00	-17.06	Peak	
2	2390.0000	37.96	6.53	44.49	54.00	-9.51	AVG	
3	2408.0000	92.77	6.51	99.28	74.00	25.28	Peak	No Limit
4 *	2411.1000	85.00	6.51	91.51	54.00	37.51	AVG	No Limit

**REMARKS:**

- (1) Measurement Value = Reading Level + Correct Factor.
- (2) Margin Level = Measurement Value - Limit Value.

Test Mode: TX G Mode 2412 MHz

### Horizontal

80 dBuV/m

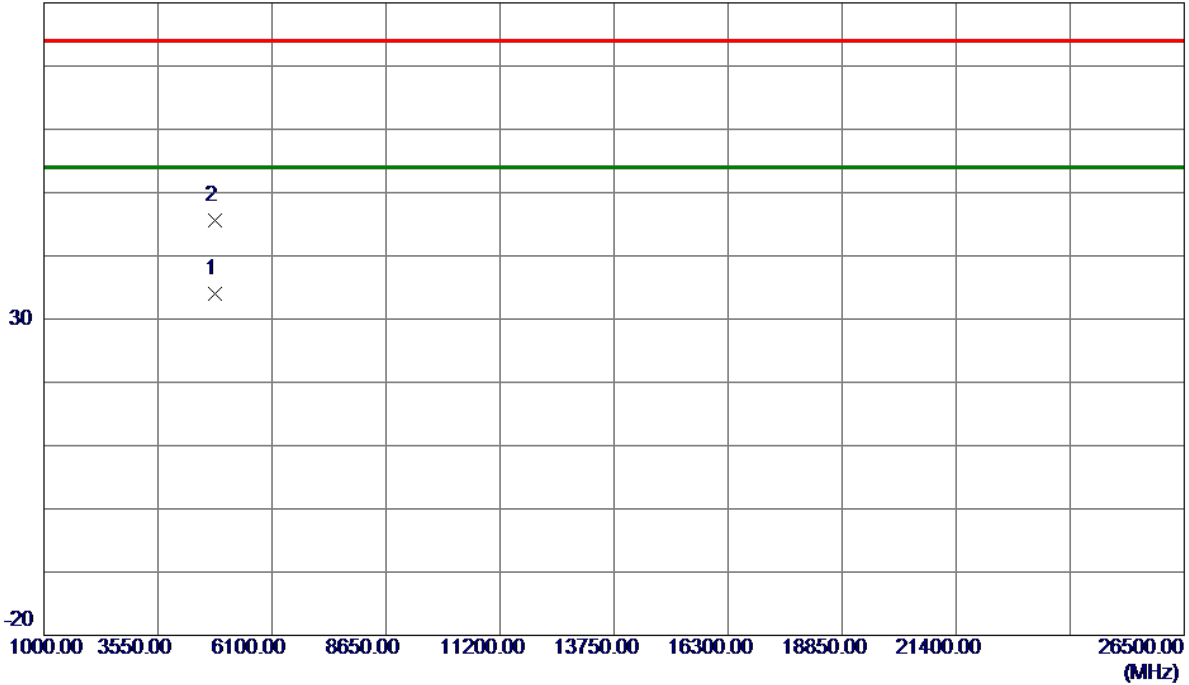

No.	Freq. MHz	Reading Level dBuV/m	Correct Factor dB	Measure ment dBuV/m	Limit dBuV/m	Margin dB	Detector	Comment
1 *	4823.8400	30.59	3.43	34.02	54.00	-19.98	AVG	
2	4824.7900	42.17	3.43	45.60	74.00	-28.40	Peak	

**REMARKS:**

- (1) Measurement Value = Reading Level + Correct Factor.
- (2) Margin Level = Measurement Value - Limit Value.

Test Mode: TX G Mode 2437 MHz

**Vertical**

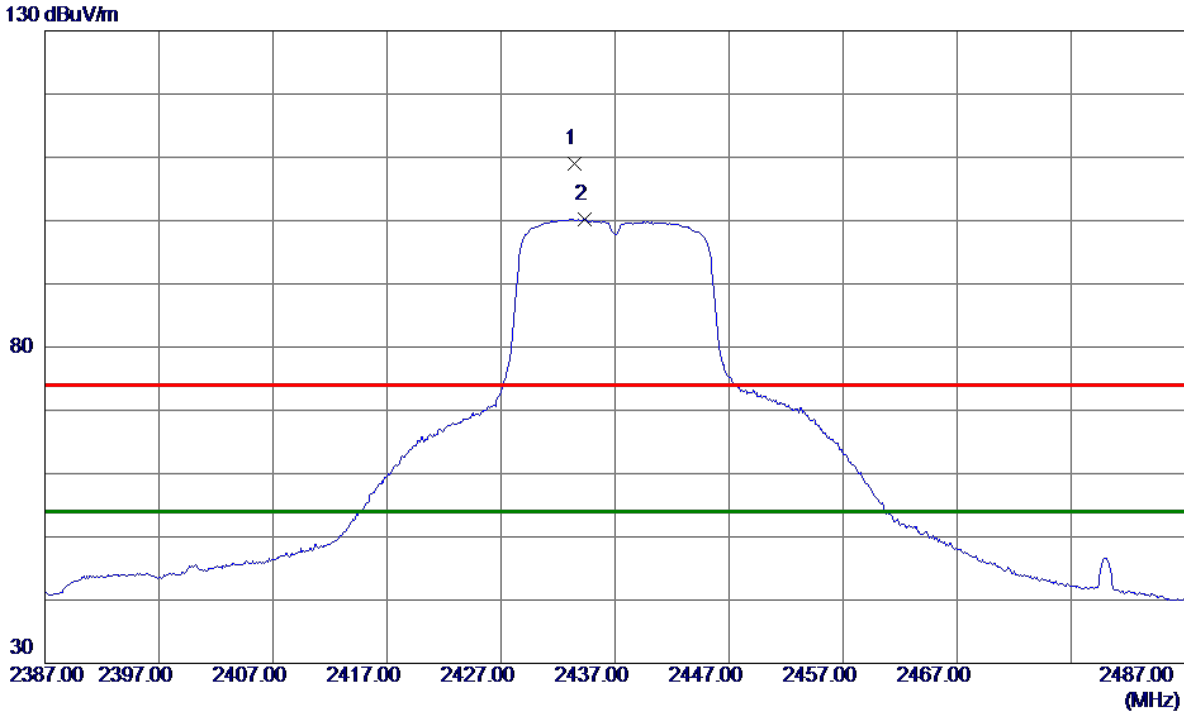

No.	Freq. MHz	Reading Level dBuV/m	Correct Factor dB	Measure ment dBuV/m	Limit dBuV/m	Margin dB	Detector	Comment
1	2433.4000	102.58	6.48	109.06	74.00	35.06	Peak	No Limit
2 *	2434.3000	93.68	6.48	100.16	54.00	46.16	AVG	No Limit

**REMARKS:**

- (1) Measurement Value = Reading Level + Correct Factor.
- (2) Margin Level = Measurement Value - Limit Value.

Test Mode: TX G Mode 2437 MHz

### Vertical

80 dBuV/m

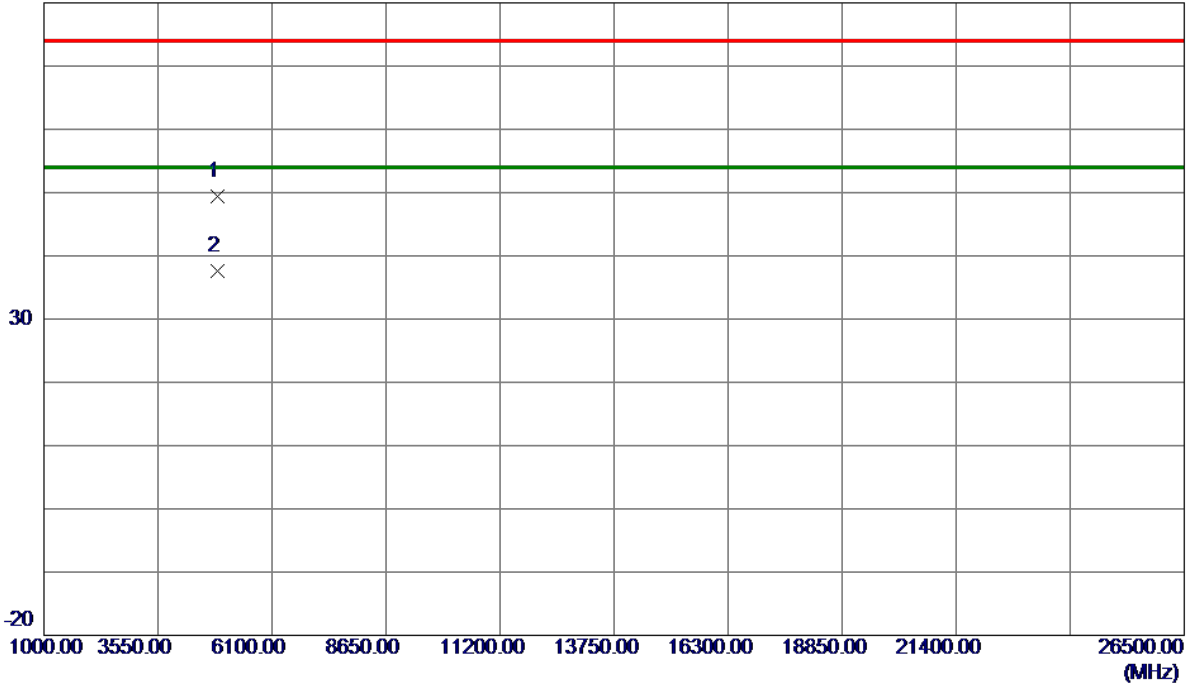

No.	Freq. MHz	Reading Level dBuV/m	Correct Factor dB	Measure ment dBuV/m	Limit dBuV/m	Margin dB	Detector	Comment
1	4873.5550	45.73	3.58	49.31	74.00	-24.69	Peak	
2 *	4873.8700	33.97	3.58	37.55	54.00	-16.45	AVG	

**REMARKS:**

- (1) Measurement Value = Reading Level + Correct Factor.
- (2) Margin Level = Measurement Value - Limit Value.

Test Mode: TX G Mode 2437 MHz

### Horizontal

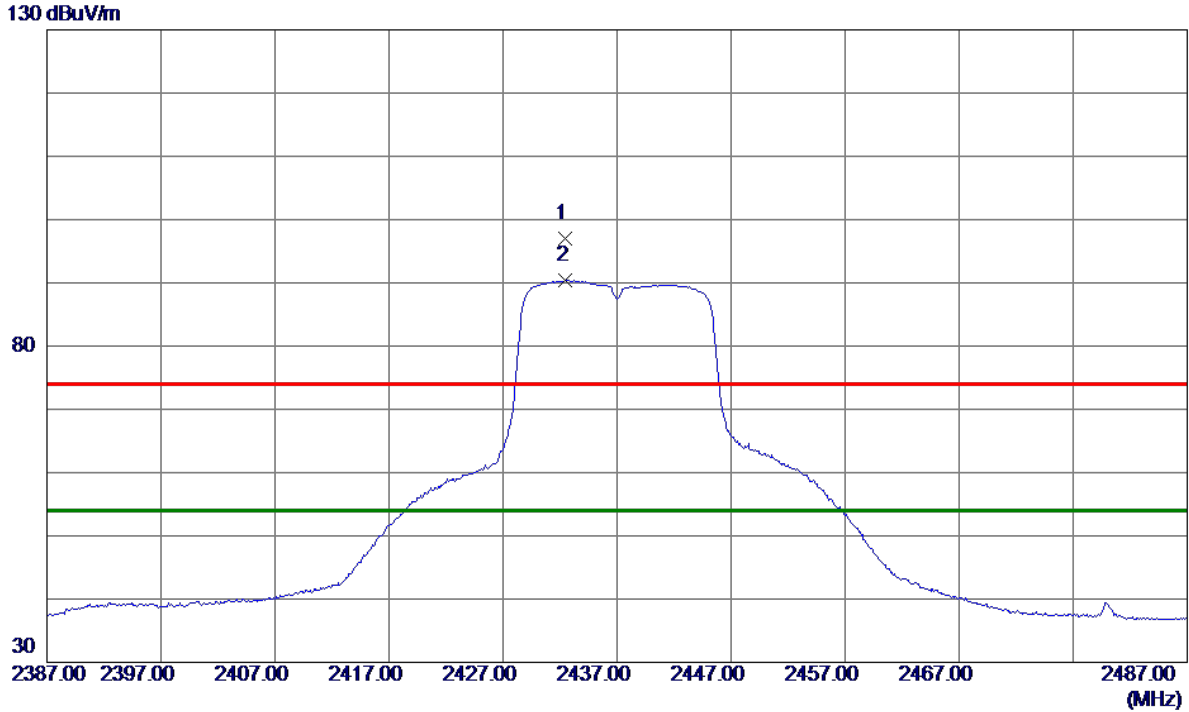

No.	Freq. MHz	Reading Level dBuV/m	Correct Factor dB	Measure ment dBuV/m	Limit dBuV/m	Margin dB	Detector	Comment
1	2432.4000	90.55	6.48	97.03	74.00	23.03	Peak	No Limit
2 *	2432.5000	83.88	6.48	90.36	54.00	36.36	AVG	No Limit

**REMARKS:**

(1) Measurement Value = Reading Level + Correct Factor.

(2) Margin Level = Measurement Value - Limit Value.

Test Mode: TX G Mode 2437 MHz

### Horizontal

80 dBuV/m

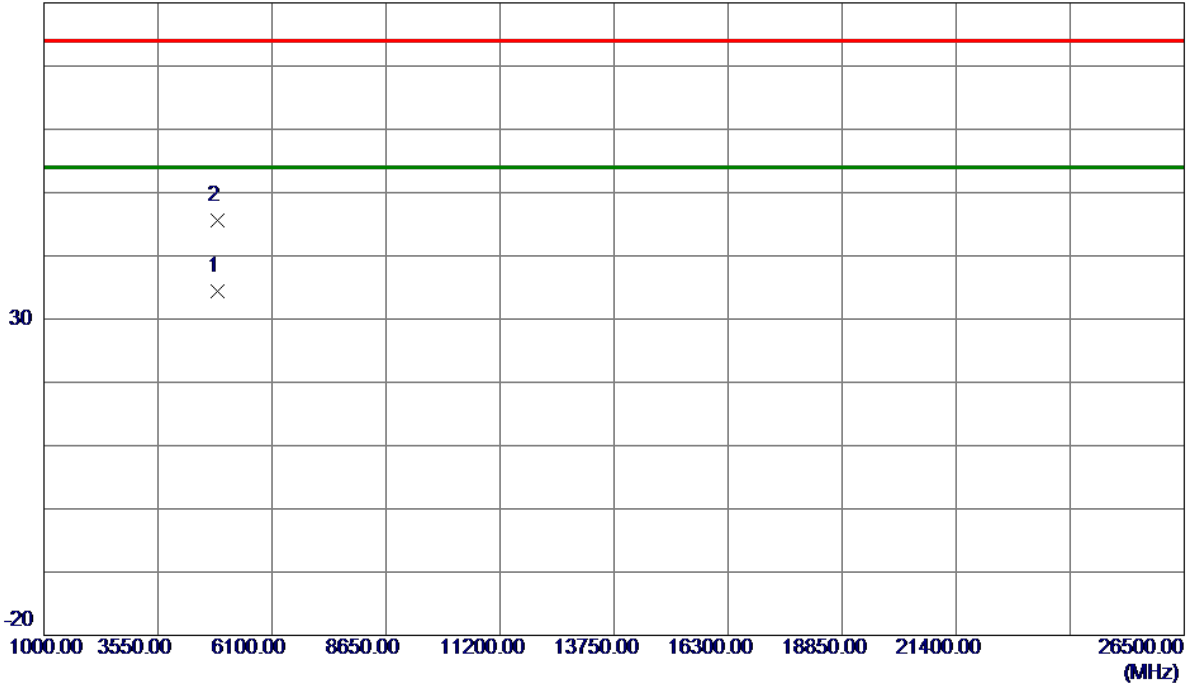

No.	Freq. MHz	Reading Level dBuV/m	Correct Factor dB	Measure ment dBuV/m	Limit dBuV/m	Margin dB	Detector	Comment
1 *	4873.8050	30.84	3.58	34.42	54.00	-19.58	AVG	
2	4874.5950	41.94	3.58	45.52	74.00	-28.48	Peak	

**REMARKS:**

- (1) Measurement Value = Reading Level + Correct Factor.
- (2) Margin Level = Measurement Value - Limit Value.

Test Mode: TX G Mode 2462 MHz

### Vertical

130 dBuV/m

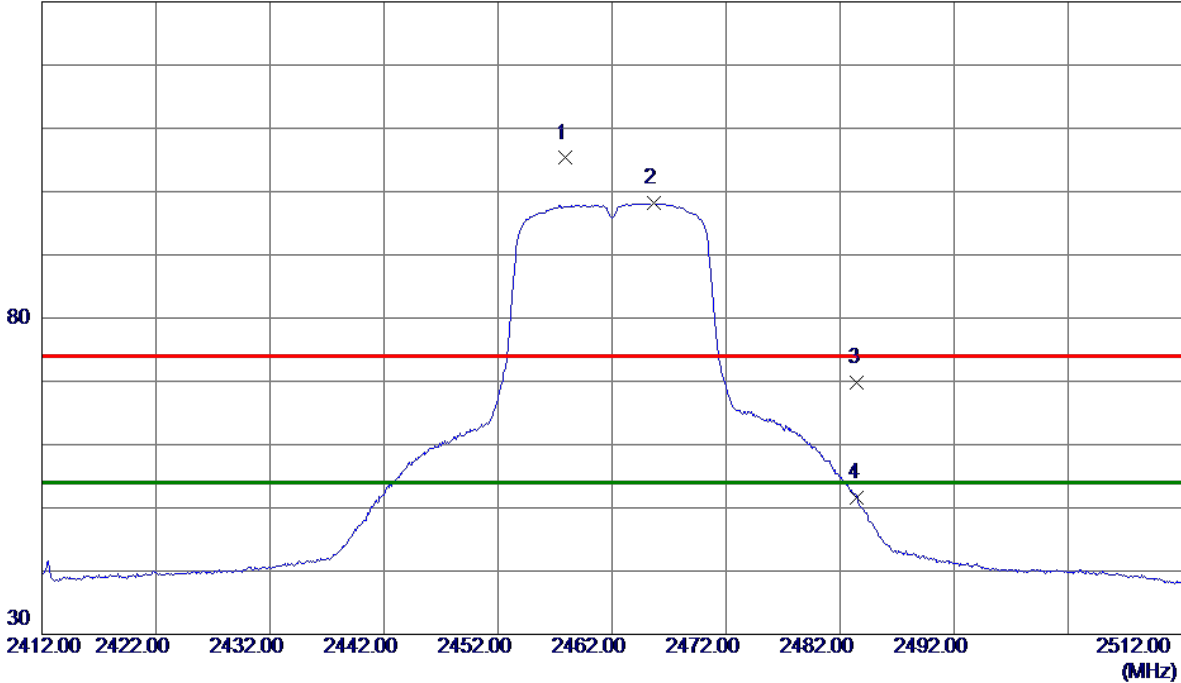

No.	Freq. MHz	Reading Level dBuV/m	Correct Factor dB	Measure ment dBuV/m	Limit dBuV/m	Margin dB	Detector	Comment
1	2457.9000	98.85	6.45	105.30	74.00	31.30	Peak	No Limit
2 *	2465.7000	91.69	6.44	98.13	54.00	44.13	AVG	No Limit
3	2483.5000	63.47	6.42	69.89	74.00	-4.11	Peak	
4	2483.5000	45.20	6.42	51.62	54.00	-2.38	AVG	

**REMARKS:**

- (1) Measurement Value = Reading Level + Correct Factor.
- (2) Margin Level = Measurement Value - Limit Value.

Test Mode: TX G Mode 2462 MHz

### Vertical

80 dBuV/m

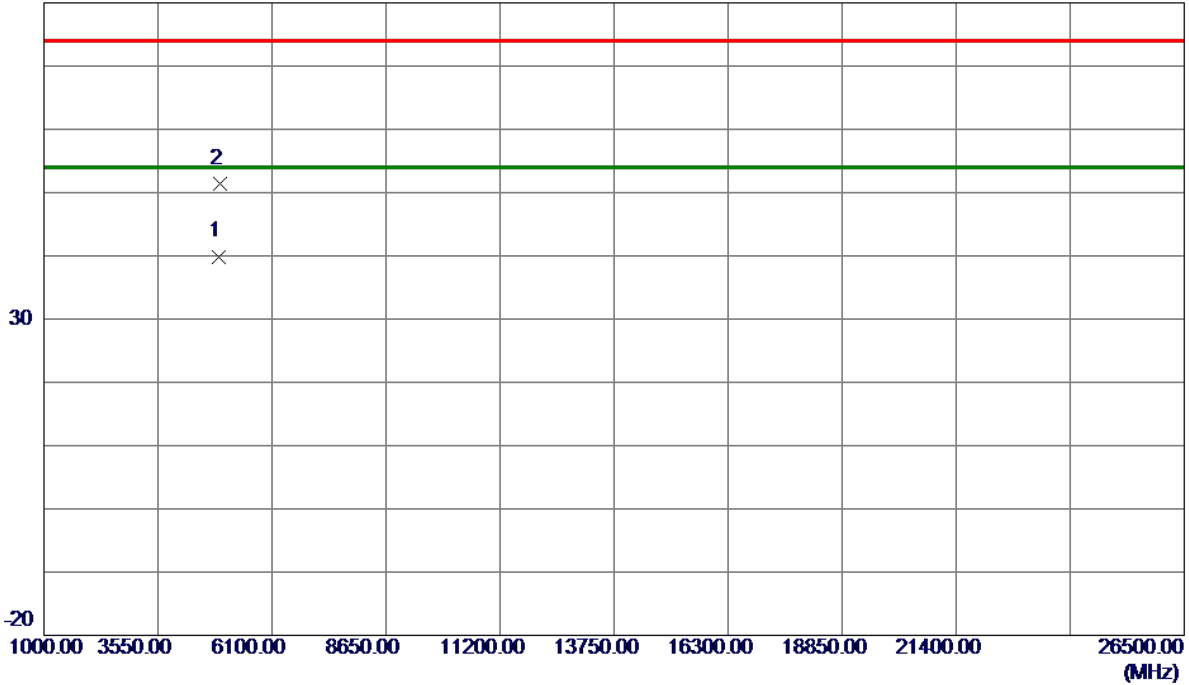

No.	Freq. MHz	Reading Level dBuV/m	Correct Factor dB	Measure ment dBuV/m	Limit dBuV/m	Margin dB	Detector	Comment
1 *	4923.7100	36.17	3.73	39.90	54.00	-14.10	AVG	
2	4924.4450	47.65	3.73	51.38	74.00	-22.62	Peak	

**REMARKS:**

- (1) Measurement Value = Reading Level + Correct Factor.
- (2) Margin Level = Measurement Value - Limit Value.



Test Mode: TX G Mode 2462 MHz

### Horizontal

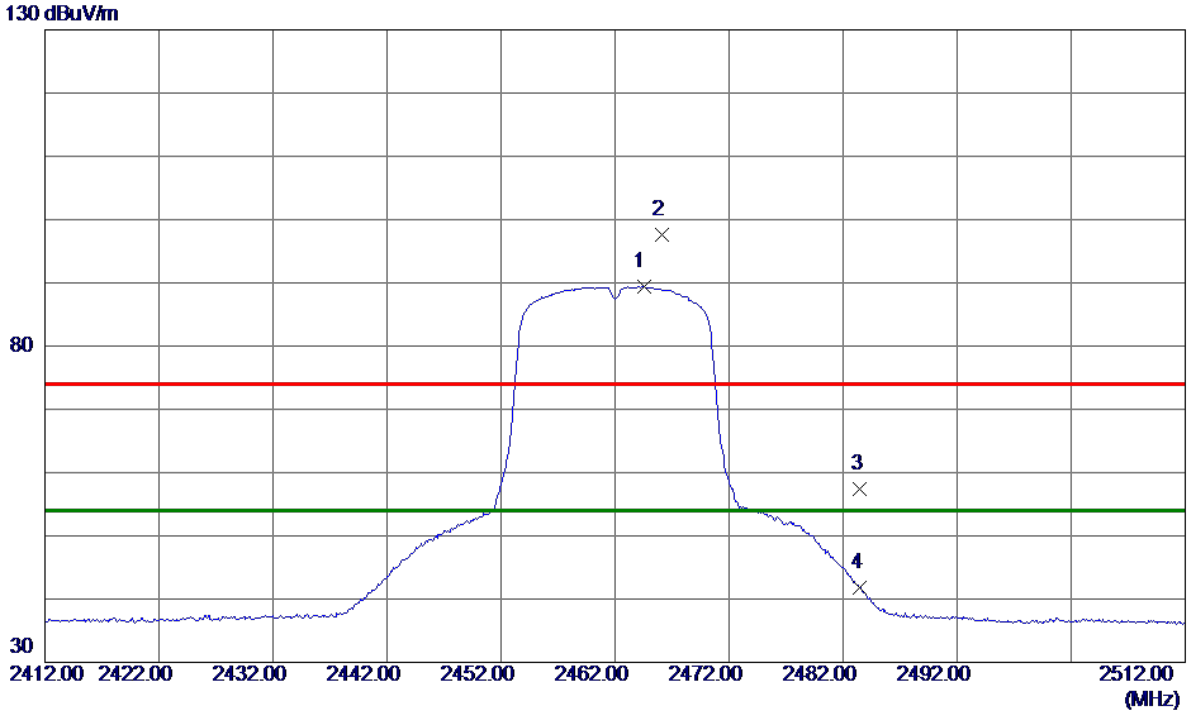

No.	Freq. MHz	Reading Level dBuV/m	Correct Factor dB	Measure ment dBuV/m	Limit dBuV/m	Margin dB	Detector	Comment
1 *	2464.5000	82.98	6.45	89.43	54.00	35.43	AVG	No Limit
2	2466.1000	91.21	6.44	97.65	74.00	23.65	Peak	No Limit
3	2483.5000	50.96	6.42	57.38	74.00	-16.62	Peak	
4	2483.5000	35.37	6.42	41.79	54.00	-12.21	AVG	

**REMARKS:**

- (1) Measurement Value = Reading Level + Correct Factor.
- (2) Margin Level = Measurement Value - Limit Value.

Test Mode: TX G Mode 2462 MHz

### Horizontal

80 dBuV/m

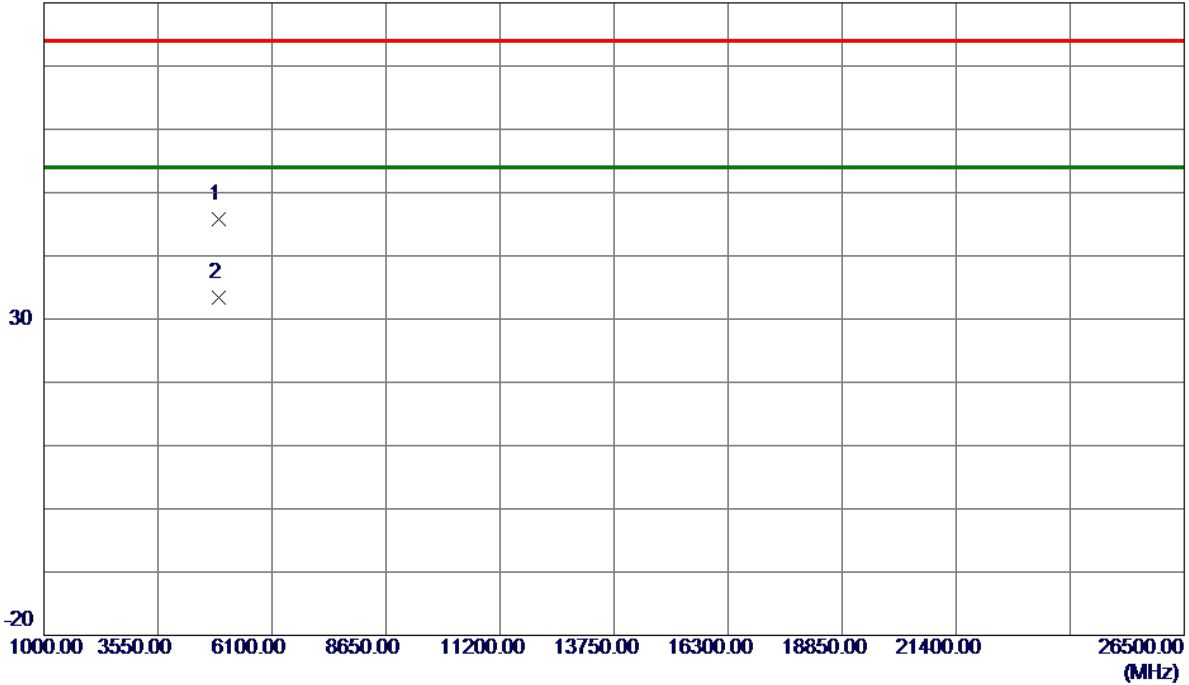

No.	Freq. MHz	Reading Level dBuV/m	Correct Factor dB	Measure ment dBuV/m	Limit dBuV/m	Margin dB	Detector	Comment
1	4922.9600	42.00	3.73	45.73	74.00	-28.27	Peak	
2 *	4923.9400	29.72	3.73	33.45	54.00	-20.55	AVG	

**REMARKS:**

- (1) Measurement Value = Reading Level + Correct Factor.
- (2) Margin Level = Measurement Value - Limit Value.

Test Mode: TX N-20M Mode 2412 MHz

### Vertical

130 dBuV/m

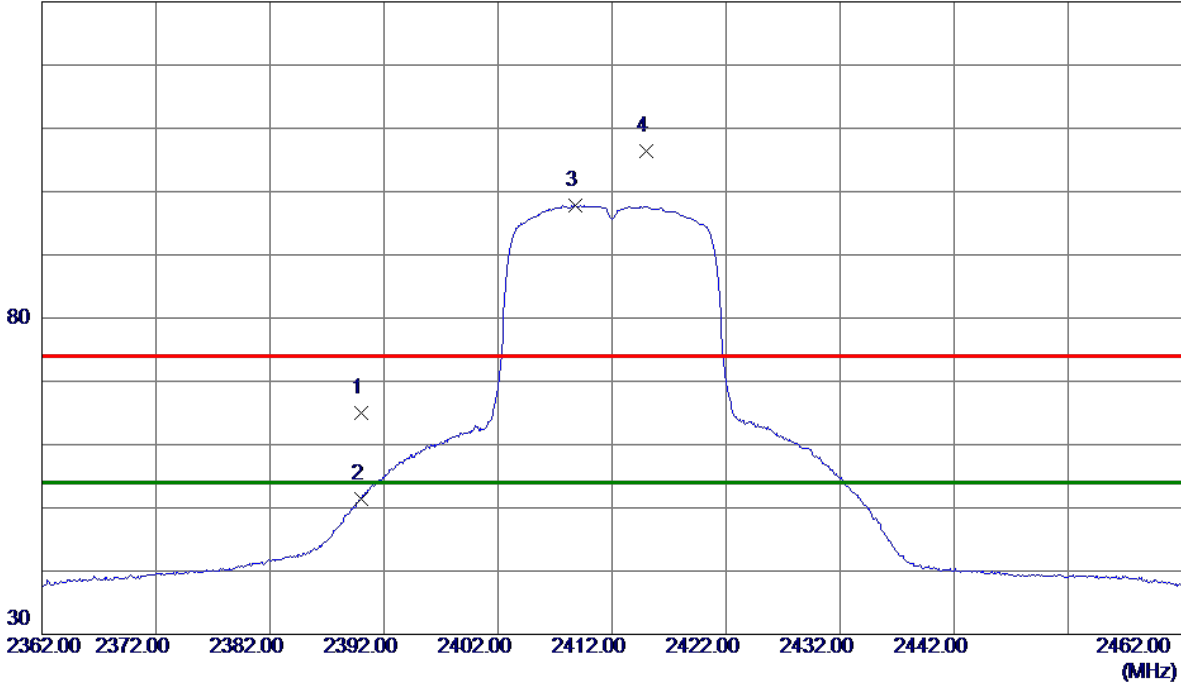

No.	Freq. MHz	Reading Level dBuV/m	Correct Factor dB	Measure ment dBuV/m	Limit dBuV/m	Margin dB	Detector	Comment
1	2390.0000	58.51	6.53	65.04	74.00	-8.96	Peak	
2	2390.0000	44.84	6.53	51.37	54.00	-2.63	AVG	
3 *	2408.8000	91.35	6.51	97.86	54.00	43.86	AVG	No Limit
4	2415.0000	99.99	6.50	106.49	74.00	32.49	Peak	No Limit

**REMARKS:**

- (1) Measurement Value = Reading Level + Correct Factor.
- (2) Margin Level = Measurement Value - Limit Value.

Test Mode: TX N-20M Mode 2412 MHz

### Vertical

80 dBuV/m

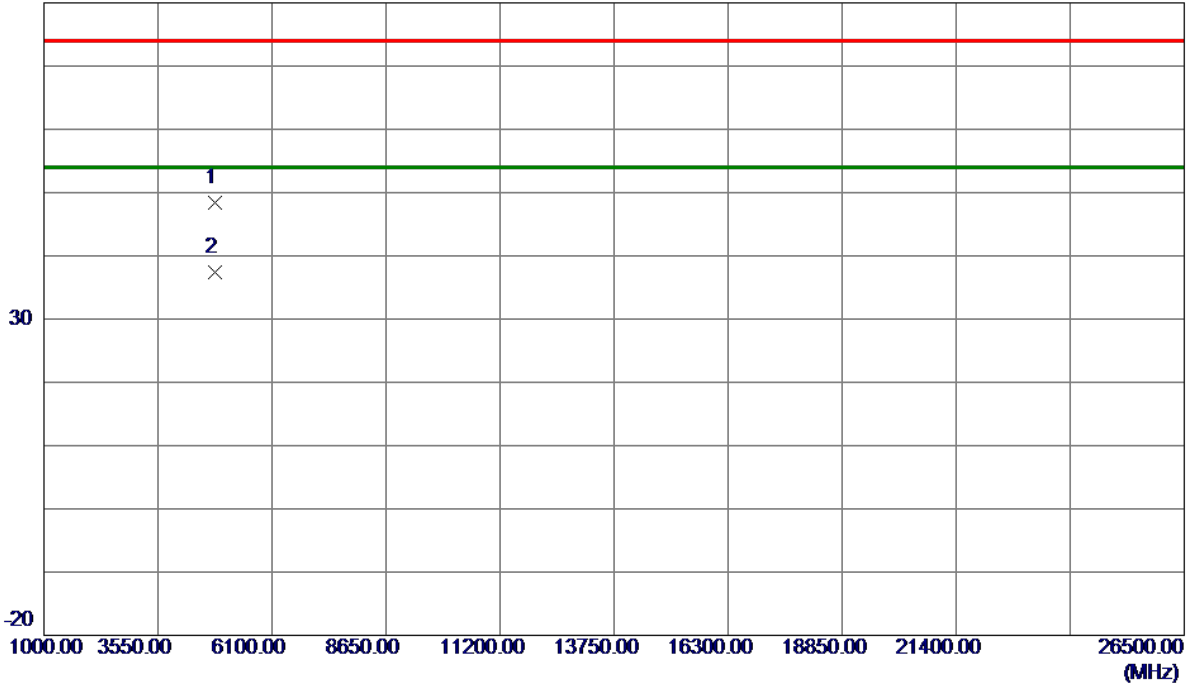

No.	Freq. MHz	Reading Level dBuV/m	Correct Factor dB	Measure ment dBuV/m	Limit dBuV/m	Margin dB	Detector	Comment
1	4823.3550	44.94	3.43	48.37	74.00	-25.63	Peak	
2 *	4823.7750	33.95	3.43	37.38	54.00	-16.62	AVG	

**REMARKS:**

- (1) Measurement Value = Reading Level + Correct Factor.
- (2) Margin Level = Measurement Value - Limit Value.

Test Mode: TX N-20M Mode 2412 MHz

### Horizontal

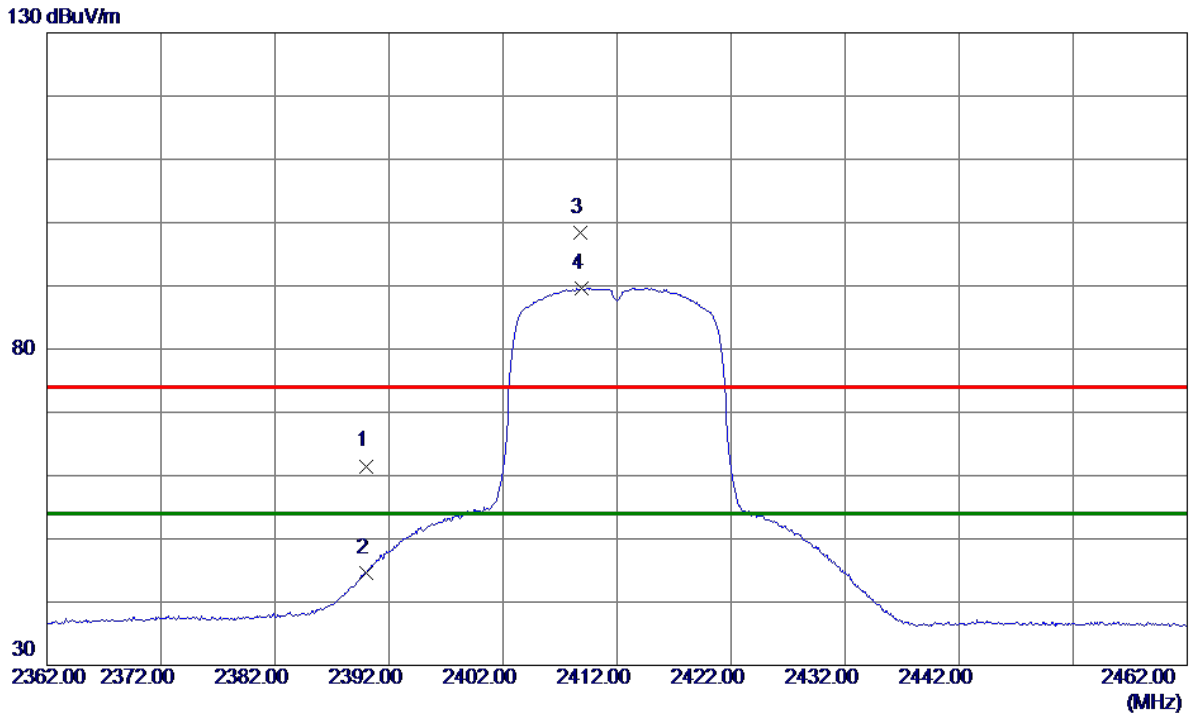

No.	Freq. MHz	Reading Level dBuV/m	Correct Factor dB	Measure ment dBuV/m	Limit dBuV/m	Margin dB	Detector	Comment
1	2390.0000	54.97	6.53	61.50	74.00	-12.50	Peak	
2	2390.0000	38.01	6.53	44.54	54.00	-9.46	AVG	
3	2408.8000	91.84	6.51	98.35	74.00	24.35	Peak	No Limit
4 *	2408.9000	83.10	6.51	89.61	54.00	35.61	AVG	No Limit

**REMARKS:**

- (1) Measurement Value = Reading Level + Correct Factor.
- (2) Margin Level = Measurement Value - Limit Value.

Test Mode: TX N-20M Mode 2412 MHz

### Horizontal

80 dBuV/m

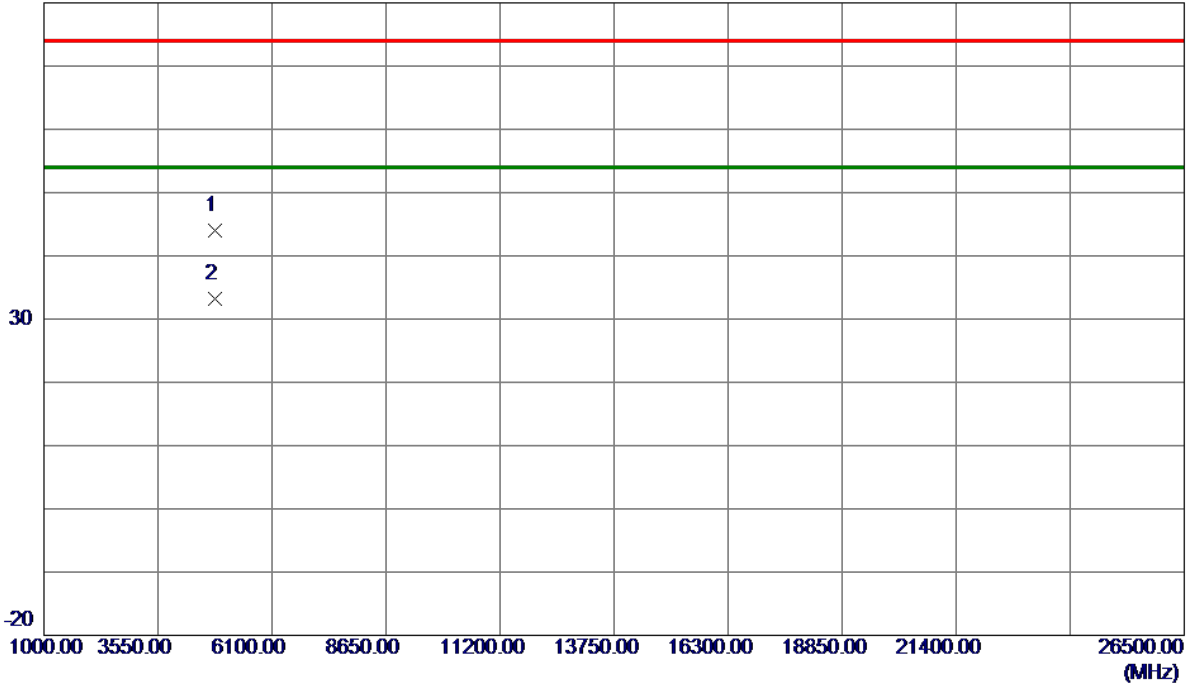

No.	Freq. MHz	Reading Level dBuV/m	Correct Factor dB	Measure ment dBuV/m	Limit dBuV/m	Margin dB	Detector	Comment
1	4821.8100	40.60	3.42	44.02	74.00	-29.98	Peak	
2 *	4823.6950	29.76	3.43	33.19	54.00	-20.81	AVG	

**REMARKS:**

- (1) Measurement Value = Reading Level + Correct Factor.
- (2) Margin Level = Measurement Value - Limit Value.

Test Mode: TX N-20M Mode 2437 MHz

### Vertical

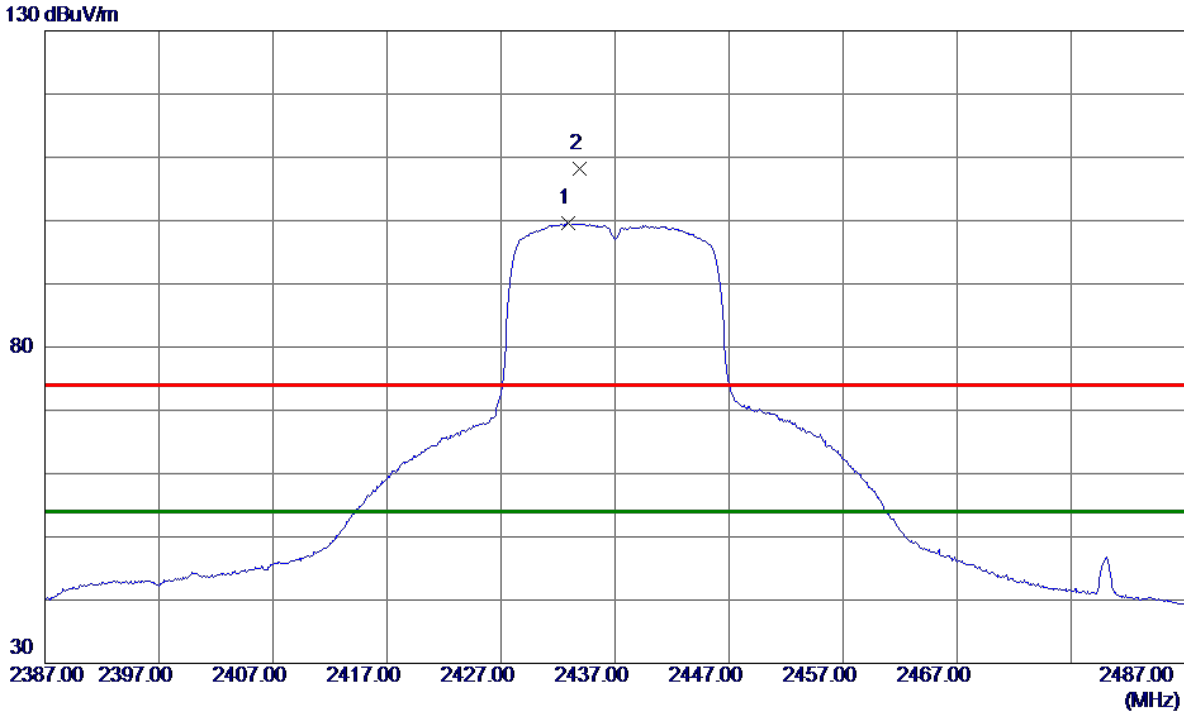

No.	Freq. MHz	Reading Level dBuV/m	Correct Factor dB	Measure ment dBuV/m	Limit dBuV/m	Margin dB	Detector	Comment
1 *	2432.9000	93.16	6.48	99.64	54.00	45.64	AVG	No Limit
2	2433.9000	101.79	6.48	108.27	74.00	34.27	Peak	No Limit

**REMARKS:**

- (1) Measurement Value = Reading Level + Correct Factor.
- (2) Margin Level = Measurement Value - Limit Value.

Test Mode: TX N-20M Mode 2437 MHz

### Vertical

80 dBuV/m

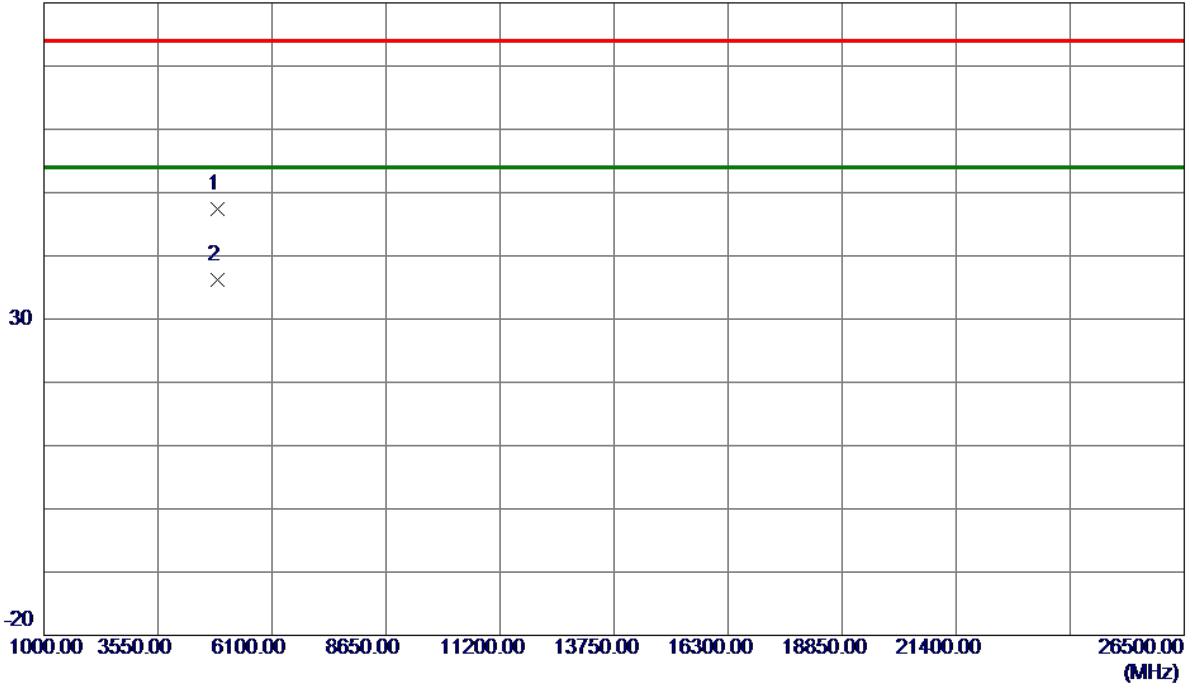

No.	Freq. MHz	Reading Level dBuV/m	Correct Factor dB	Measure ment dBuV/m	Limit dBuV/m	Margin dB	Detector	Comment
1	4872.2200	43.81	3.58	47.39	74.00	-26.61	Peak	
2 *	4873.9350	32.65	3.58	36.23	54.00	-17.77	AVG	

**REMARKS:**

- (1) Measurement Value = Reading Level + Correct Factor.
- (2) Margin Level = Measurement Value - Limit Value.



Test Mode: TX N-20M Mode 2437 MHz

### Horizontal

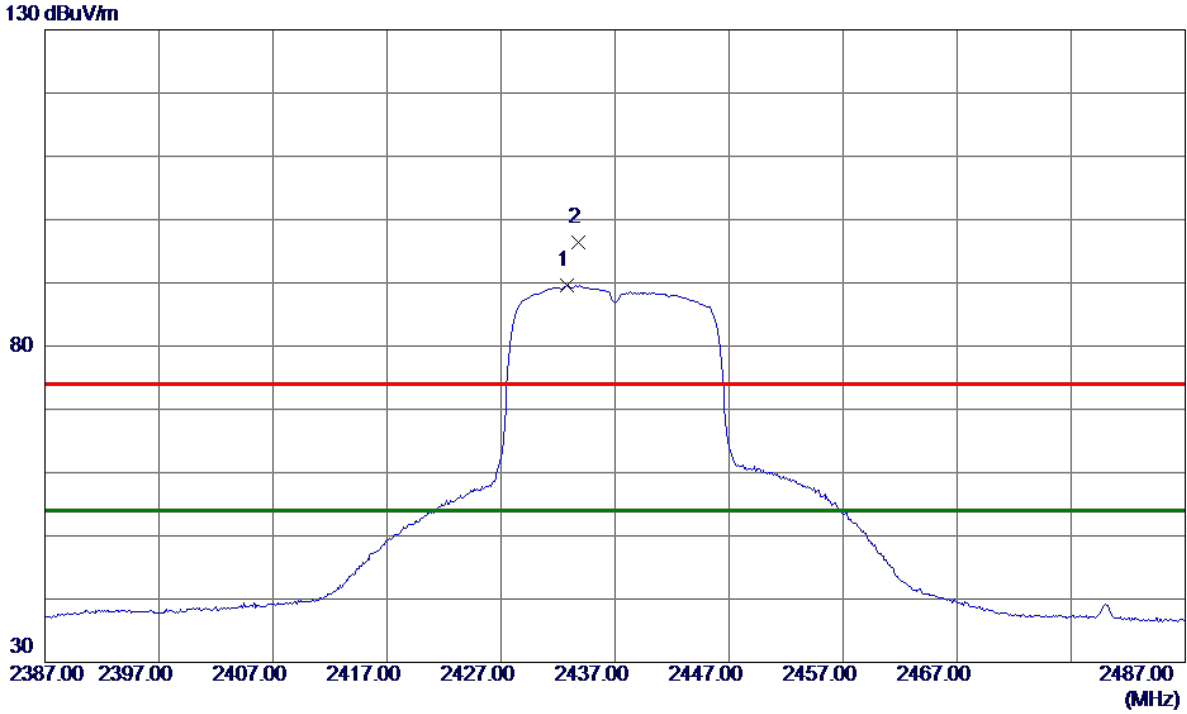

No.	Freq. MHz	Reading Level dBuV/m	Correct Factor dB	Measure ment dBuV/m	Limit dBuV/m	Margin dB	Detector	Comment
1 *	2432.8000	83.07	6.48	89.55	54.00	35.55	AVG	No Limit
2	2433.8000	89.98	6.48	96.46	74.00	22.46	Peak	No Limit

**REMARKS:**

- (1) Measurement Value = Reading Level + Correct Factor.
- (2) Margin Level = Measurement Value - Limit Value.

Test Mode: TX N-20M Mode 2437 MHz

### Horizontal

80 dBuV/m

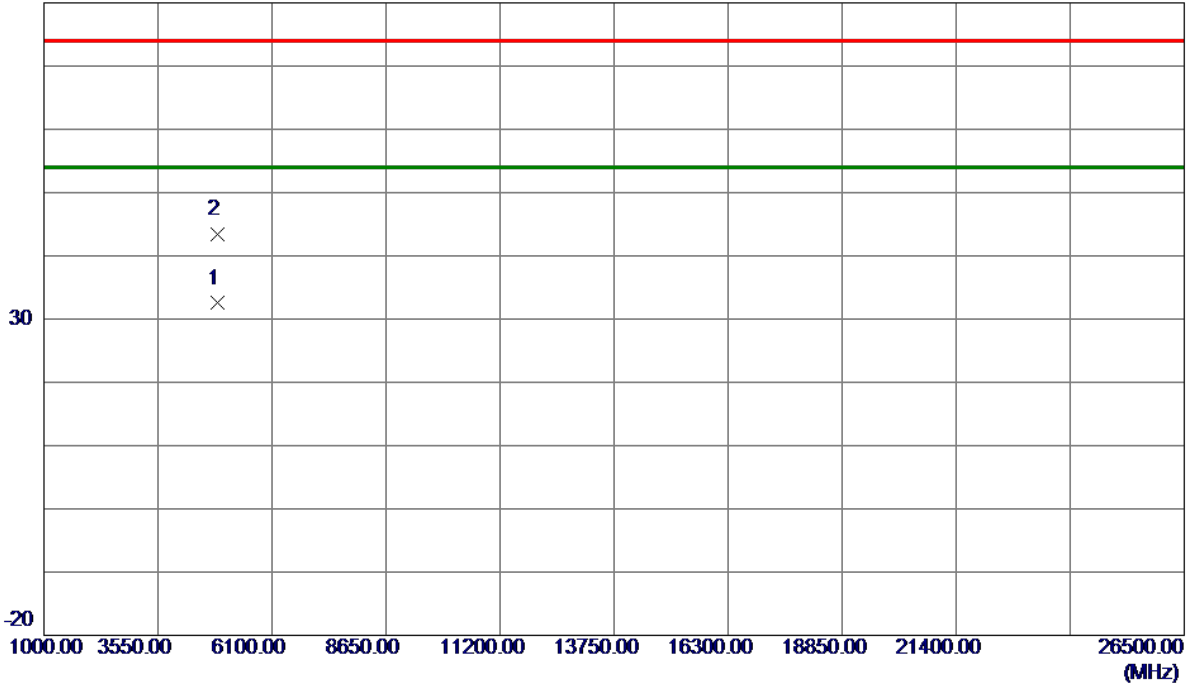

No.	Freq. MHz	Reading Level dBuV/m	Correct Factor dB	Measure ment dBuV/m	Limit dBuV/m	Margin dB	Detector	Comment
1 *	4873.9850	28.92	3.58	32.50	54.00	-21.50	AVG	
2	4875.3650	39.77	3.58	43.35	74.00	-30.65	Peak	

**REMARKS:**

- (1) Measurement Value = Reading Level + Correct Factor.
- (2) Margin Level = Measurement Value - Limit Value.

Test Mode: TX N-20M Mode 2462 MHz

### Vertical

130 dBuV/m

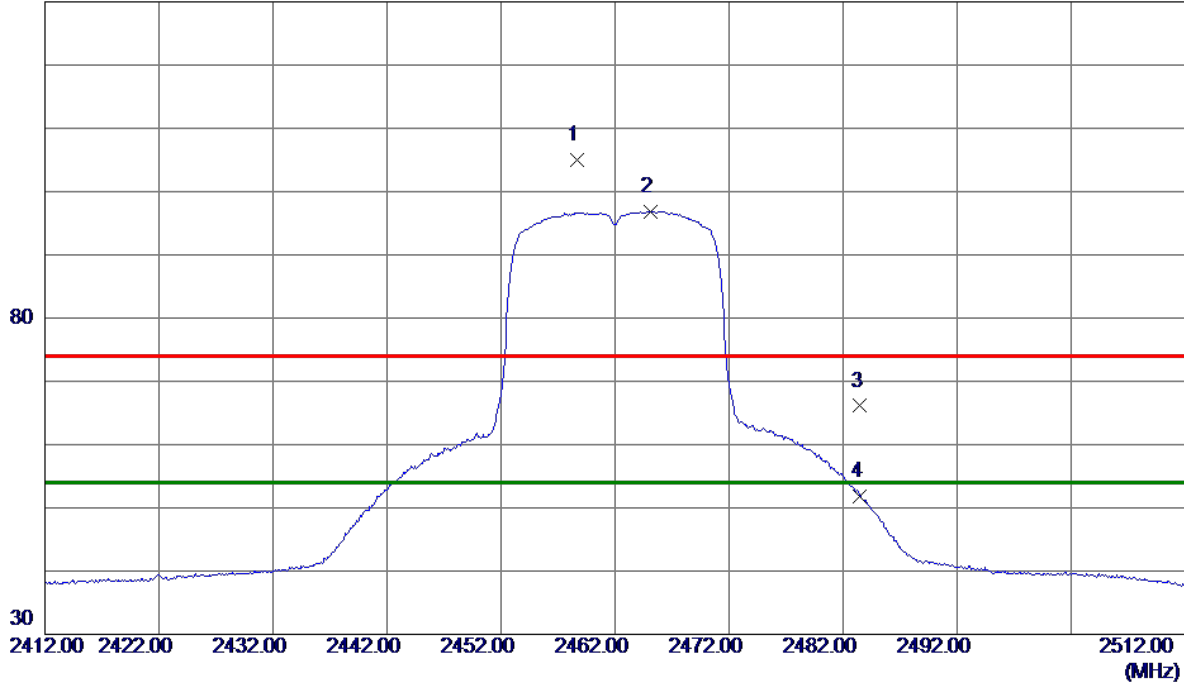

No.	Freq. MHz	Reading Level dBuV/m	Correct Factor dB	Measure ment dBuV/m	Limit dBuV/m	Margin dB	Detector	Comment
1	2458.7000	98.52	6.45	104.97	74.00	30.97	Peak	No Limit
2 *	2465.1000	90.44	6.45	96.89	54.00	42.89	AVG	No Limit
3	2483.5000	59.68	6.42	66.10	74.00	-7.90	Peak	
4	2483.5000	45.33	6.42	51.75	54.00	-2.25	AVG	

**REMARKS:**

- (1) Measurement Value = Reading Level + Correct Factor.
- (2) Margin Level = Measurement Value - Limit Value.

Test Mode: TX N-20M Mode 2462 MHz

### Vertical

80 dBuV/m

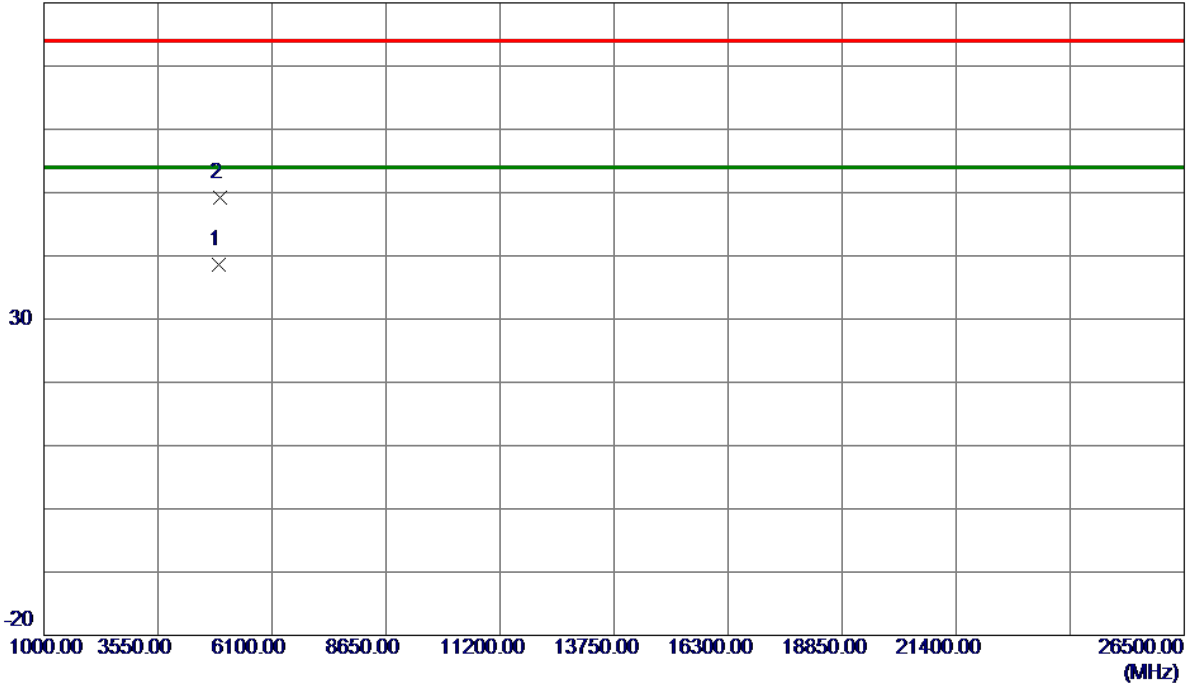

No.	Freq. MHz	Reading Level dBuV/m	Correct Factor dB	Measure ment dBuV/m	Limit dBuV/m	Margin dB	Detector	Comment
1 *	4923.7000	34.82	3.73	38.55	54.00	-15.45	AVG	
2	4928.4000	45.52	3.74	49.26	74.00	-24.74	Peak	

**REMARKS:**

- (1) Measurement Value = Reading Level + Correct Factor.
- (2) Margin Level = Measurement Value - Limit Value.

Test Mode: TX N-20M Mode 2462 MHz

### Horizontal

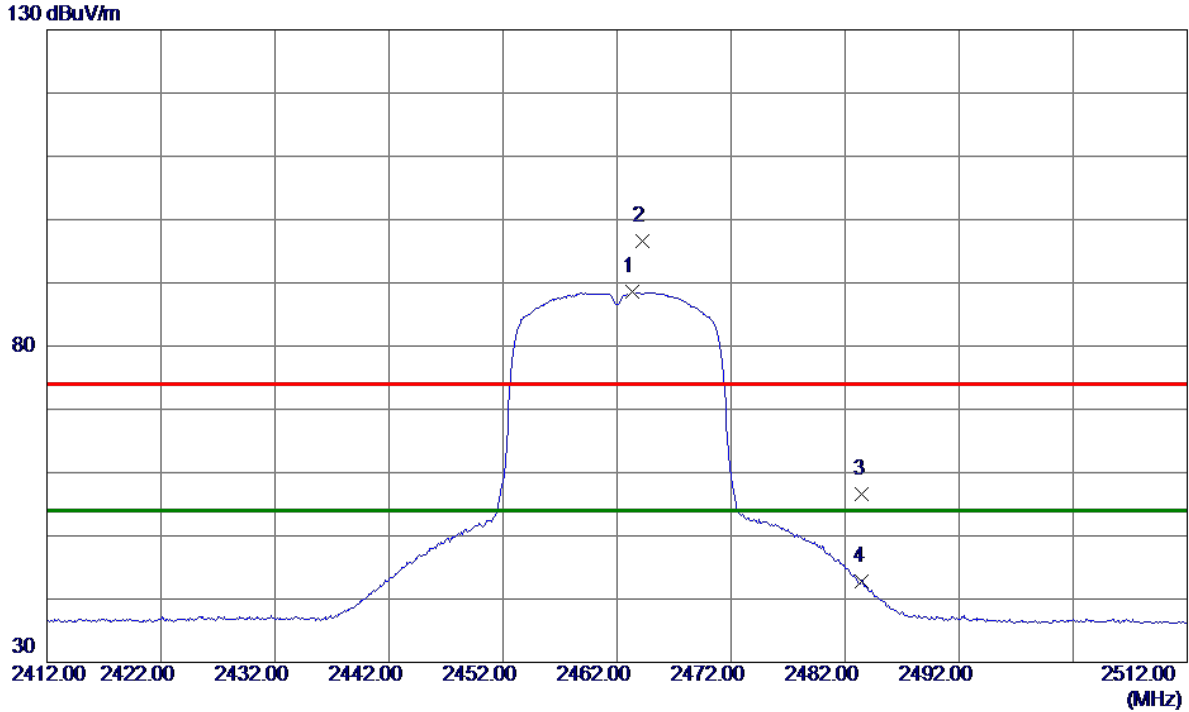

No.	Freq. MHz	Reading Level dBuV/m	Correct Factor dB	Measure ment dBuV/m	Limit dBuV/m	Margin dB	Detector	Comment
1 *	2463.3000	82.08	6.45	88.53	54.00	34.53	AVG	No Limit
2	2464.2000	90.22	6.45	96.67	74.00	22.67	Peak	No Limit
3	2483.5000	50.09	6.42	56.51	74.00	-17.49	Peak	
4	2483.5000	36.33	6.42	42.75	54.00	-11.25	AVG	

**REMARKS:**

- (1) Measurement Value = Reading Level + Correct Factor.
- (2) Margin Level = Measurement Value - Limit Value.

Test Mode: TX N-20M Mode 2462 MHz

### Horizontal

80 dBuV/m

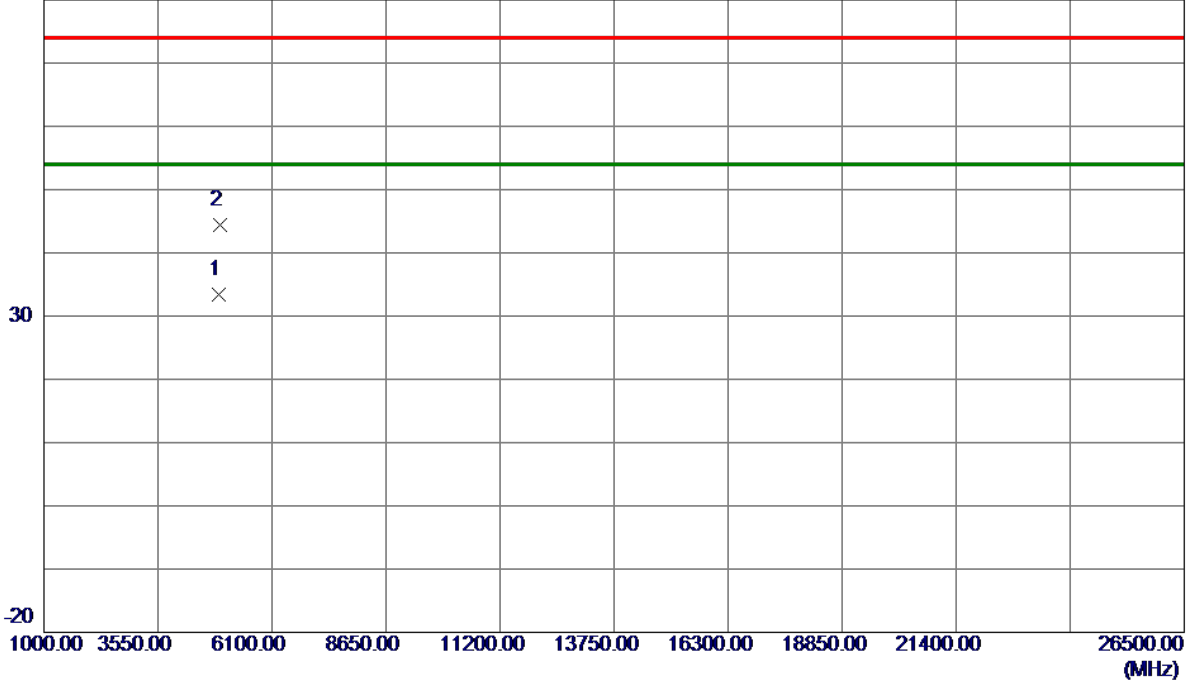

No.	Freq. MHz	Reading Level dBuV/m	Correct Factor dB	Measure ment dBuV/m	Limit dBuV/m	Margin dB	Detector	Comment
1 *	4924.0350	29.58	3.73	33.31	54.00	-20.69	AVG	
2	4924.3600	40.58	3.73	44.31	74.00	-29.69	Peak	

**REMARKS:**

- (1) Measurement Value = Reading Level + Correct Factor.
- (2) Margin Level = Measurement Value - Limit Value.

# APPENDIX E - BANDWIDTH

Test Mode	TX B Mode
-----------	-----------

Channel	Frequency (MHz)	6 dB Bandwidth (MHz)	6 dB Bandwidth Min. Limit (kHz)	Result
01	2412	7.65	13.60	Complies
06	2437	8.64	13.44	Complies
11	2462	9.60	13.44	Complies

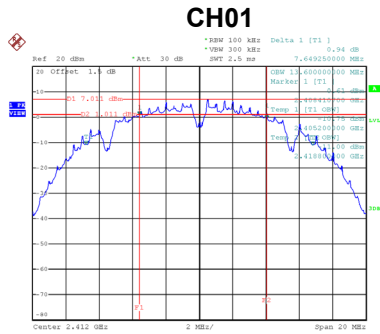

Date: 25.NOV.2019 09:21:18

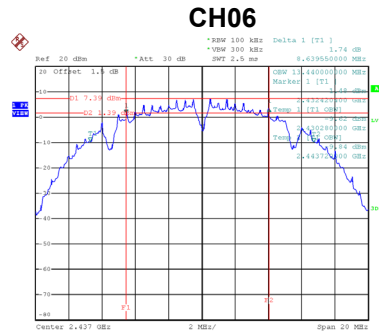

Date: 25.NOV.2019 09:24:27

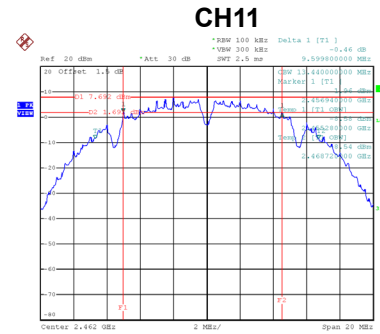

Date: 25.NOV.2019 09:27:130

Channel	Frequency (MHz)	99 % Emission Bandwidth (MHz)	Result
01	2412	13.50	Complies
06	2437	13.40	Complies
11	2462	13.30	Complies

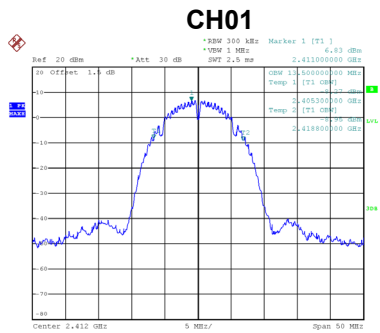

Date: 25.NOV.2019 09:22:139

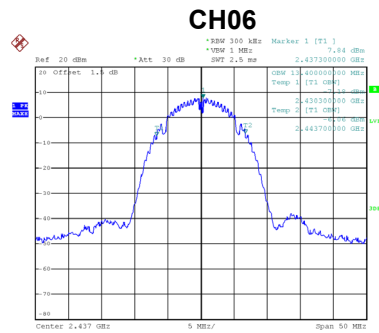

Date: 25.NOV.2019 09:23:103

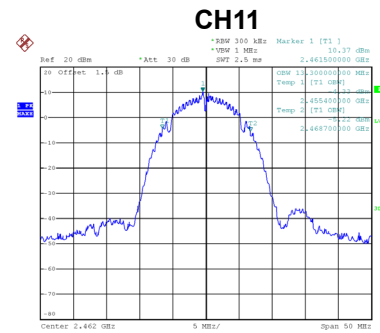

Date: 25.NOV.2019 09:28:25



Test Mode	TX G Mode
-----------	-----------

Channel	Frequency (MHz)	6 dB Bandwidth (MHz)	6 dB Bandwidth Min. Limit (kHz)	Result
01	2412	15.19	16.32	Complies
06	2437	15.36	16.32	Complies
11	2462	15.22	16.32	Complies

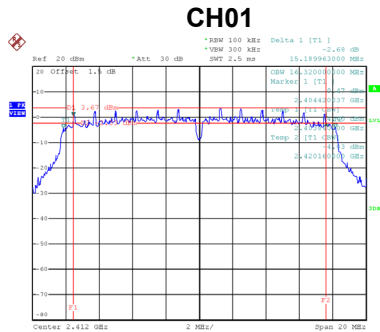

Date: 25.NOV.2019 09:29:19

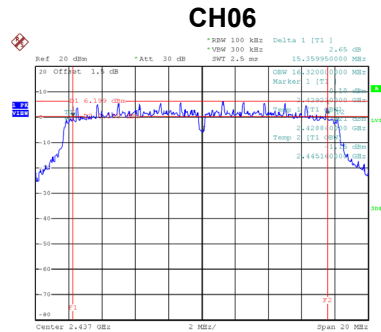

Date: 25.NOV.2019 09:30:43

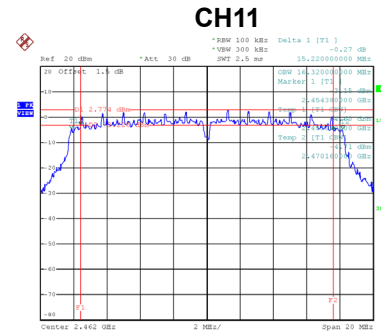

Date: 25.NOV.2019 09:32:29

Channel	Frequency (MHz)	99 % Emission Bandwidth (MHz)	Result
01	2412	16.60	Complies
06	2437	16.80	Complies
11	2462	16.60	Complies

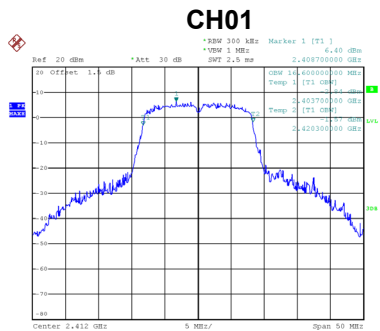

Date: 25.NOV.2019 09:28:48

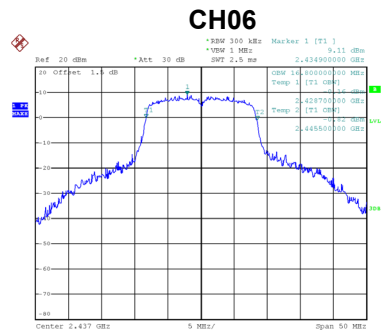

Date: 25.NOV.2019 09:31:43

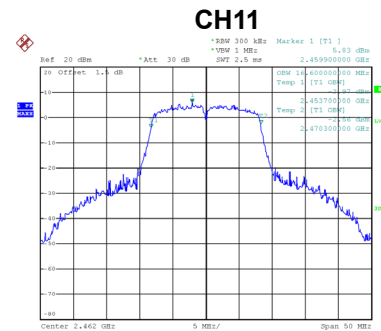

Date: 25.NOV.2019 09:32:00

Test Mode	TX N-20M Mode
-----------	---------------

Channel	Frequency (MHz)	6 dB Bandwidth (MHz)	6 dB Bandwidth Min. Limit (kHz)	Result
01	2412	15.18	17.52	Complies
06	2437	15.17	17.48	Complies
11	2462	15.15	17.48	Complies

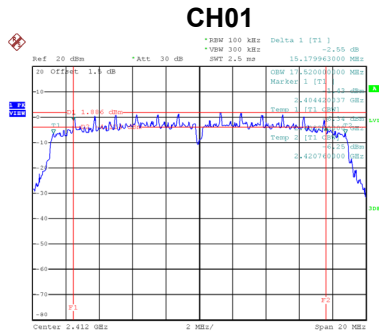

Date: 25.NOV.2019 09:15:45

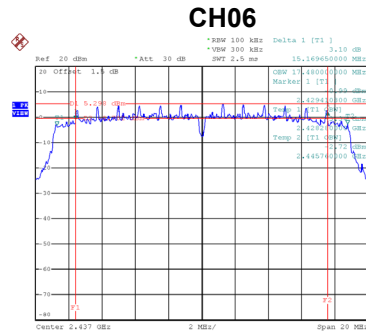

Date: 25.NOV.2019 09:17:12

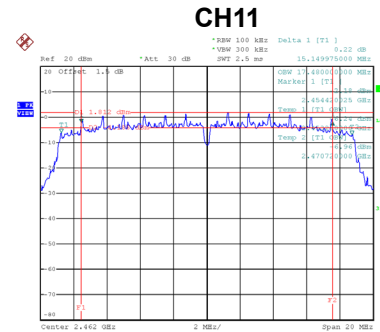

Date: 25.NOV.2019 09:14:13

Channel	Frequency (MHz)	99 % Emission Bandwidth (MHz)	Result
01	2412	17.70	Complies
06	2437	17.70	Complies
11	2462	17.70	Complies

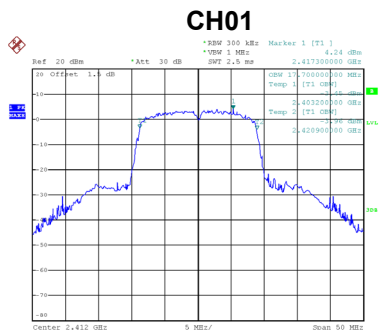

Date: 25.NOV.2019 09:16:42

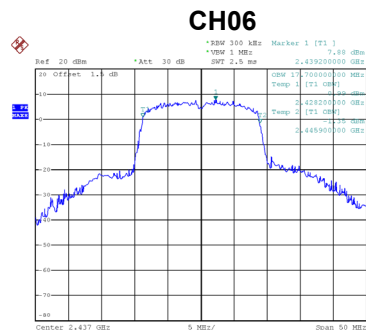

Date: 25.NOV.2019 09:17:01

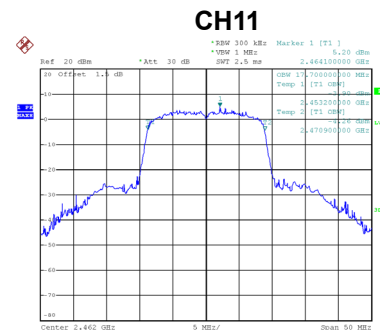

Date: 25.NOV.2019 09:14:16

## **APPENDIX F - MAXIMUM OUTPUT POWER**

Test Mode	TX B Mode
-----------	-----------

Channel	Frequency (MHz)	Output Power (dBm)	Duty Factor	Output Power + Duty Factor (dBm)	Max. Limit (dBm)	Max. Limit (W)	Result
01	2412	16.51	0.20	16.71	30.00	1.0000	Complies
06	2437	17.21	0.20	17.41	30.00	1.0000	Complies
11	2462	17.35	0.20	17.55	30.00	1.0000	Complies

Test Mode	TX G Mode
-----------	-----------

Channel	Frequency (MHz)	Output Power (dBm)	Duty Factor	Output Power + Duty Factor (dBm)	Max. Limit (dBm)	Max. Limit (W)	Result
01	2412	15.02	0.27	15.29	30.00	1.0000	Complies
06	2437	16.68	0.27	16.95	30.00	1.0000	Complies
11	2462	14.13	0.27	14.40	30.00	1.0000	Complies

Test Mode	TX N-20M Mode
-----------	---------------

Channel	Frequency (MHz)	Output Power (dBm)	Duty Factor	Output Power + Duty Factor (dBm)	Max. Limit (dBm)	Max. Limit (W)	Result
01	2412	13.34	0.29	13.63	30.00	1.0000	Complies
06	2437	15.71	0.29	16.00	30.00	1.0000	Complies
11	2462	13.19	0.29	13.48	30.00	1.0000	Complies

## **APPENDIX G - CONDUCTED SPURIOUS EMISSIONS**

Test Mode TX B Mode

### Bandedge-CH01

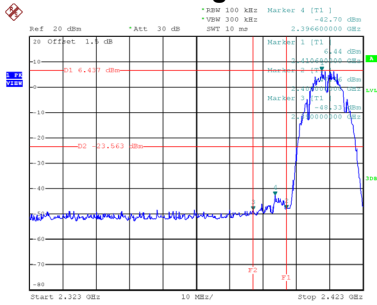

Date: 25.NOV.2019 09:21:25

### Bandedge-CH11

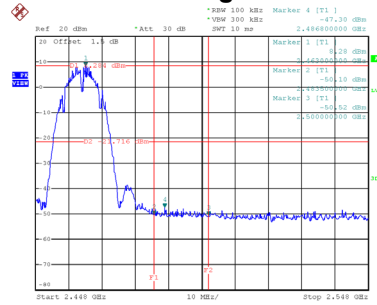

Date: 25.NOV.2019 09:27:38

### CH01 – 10th Harmonic of the fundamental frequency

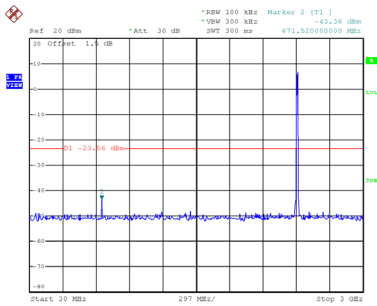

Date: 25.NOV.2019 09:21:38

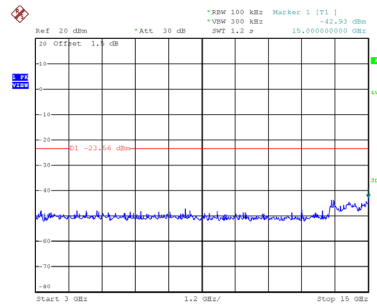

Date: 25.NOV.2019 09:21:45

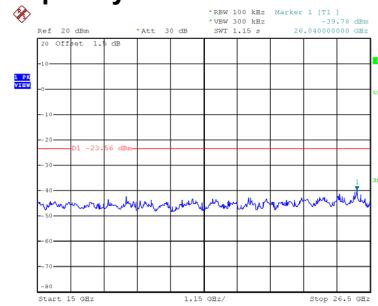

Date: 25.NOV.2019 09:21:52

### CH06 – 10th Harmonic of the fundamental frequency

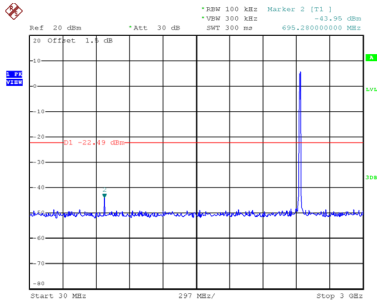

Date: 25.NOV.2019 09:24:49

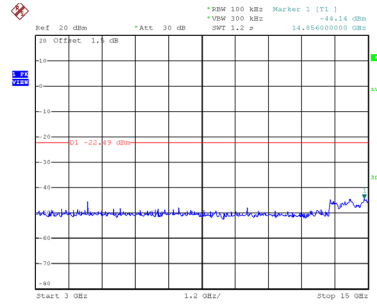

Date: 25.NOV.2019 09:24:57

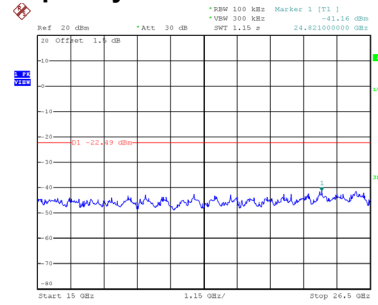

Date: 25.NOV.2019 09:25:05

### CH11 – 10th Harmonic of the fundamental frequency

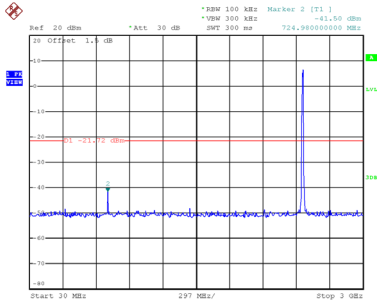

Date: 25.NOV.2019 09:27:52

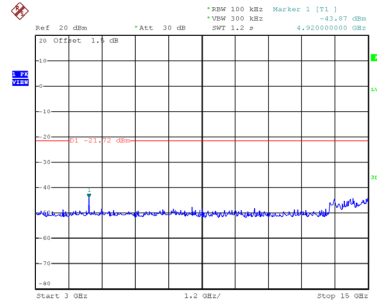

Date: 25.NOV.2019 09:28:00

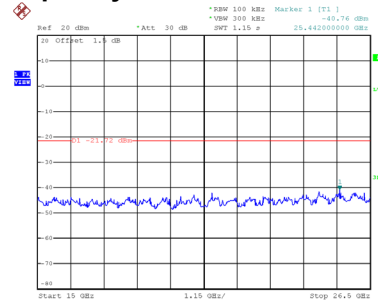

Date: 25.NOV.2019 09:28:08

Test Mode TX G Mode

### Bandedge-CH01

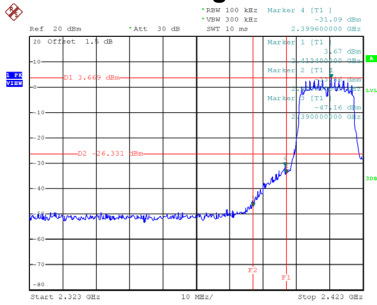

Date: 25.NOV.2019 09:29:27

### Bandedge-CH11

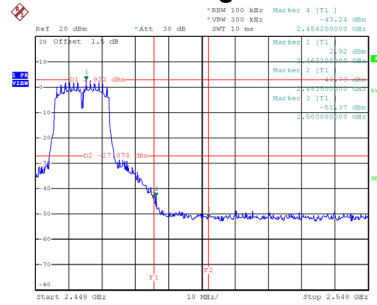

Date: 25.NOV.2019 09:32:37

### CH01 – 10th Harmonic of the fundamental frequency

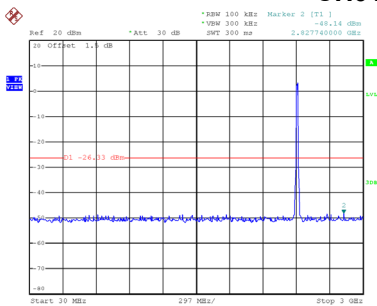

Date: 25.NOV.2019 09:29:41

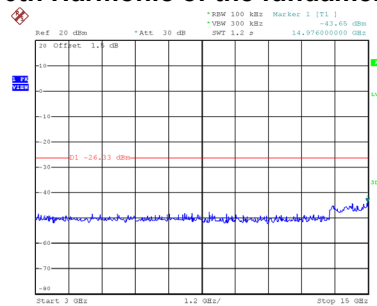

Date: 25.NOV.2019 09:29:49

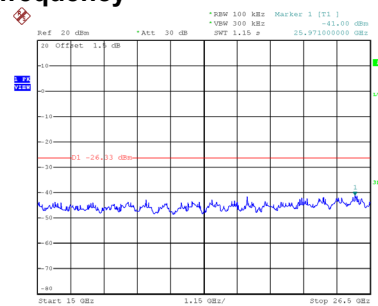

Date: 25.NOV.2019 09:29:57

### CH06 – 10th Harmonic of the fundamental frequency

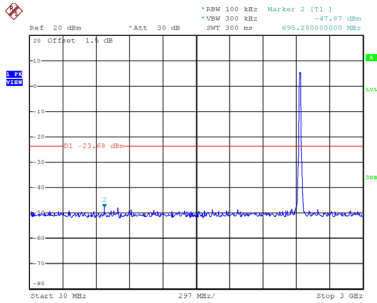

Date: 25.NOV.2019 09:31:05

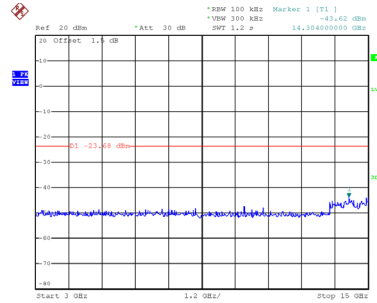

Date: 25.NOV.2019 09:31:13

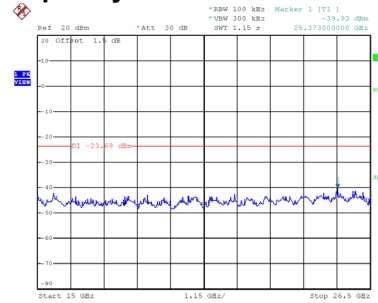

Date: 25.NOV.2019 09:31:22

### CH11 – 10th Harmonic of the fundamental frequency

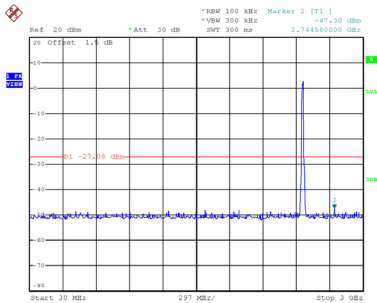

Date: 25.NOV.2019 09:32:51

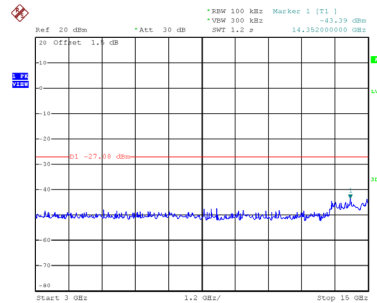

Date: 25.NOV.2019 09:32:59

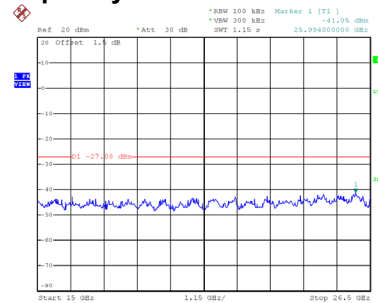

Date: 25.NOV.2019 09:33:07

Test Mode TX N-20M Mode

### Bandedge-CH01

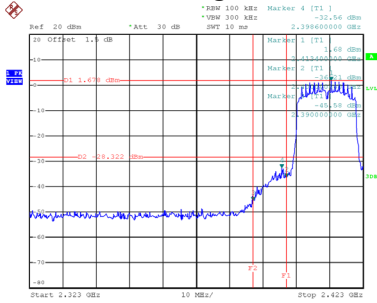

Date: 25.NOV.2019 09:35:53

### Bandedge-CH11

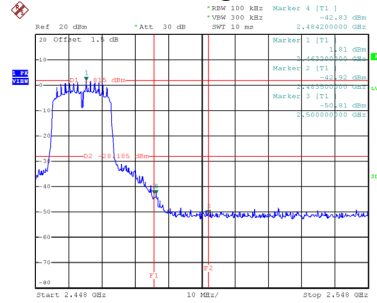

Date: 25.NOV.2019 09:40:40

### CH01 – 10th Harmonic of the fundamental frequency

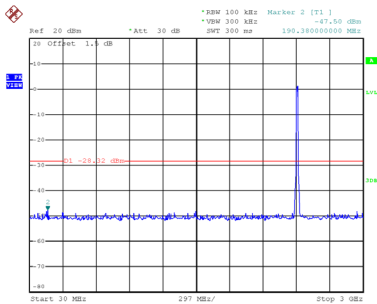

Date: 25.NOV.2019 09:36:07

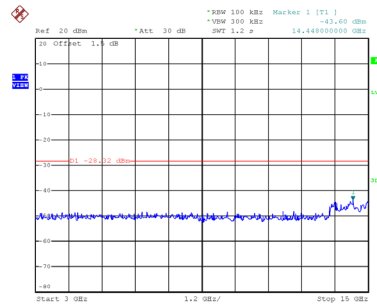

Date: 25.NOV.2019 09:36:15

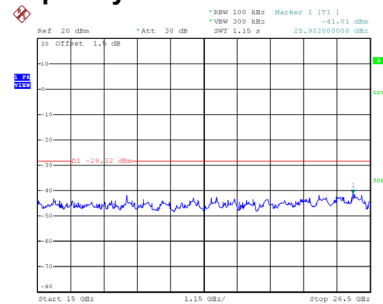

Date: 25.NOV.2019 09:36:23

### CH06 – 10th Harmonic of the fundamental frequency

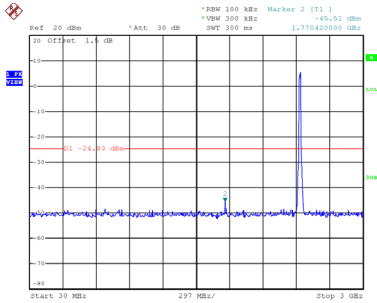

Date: 25.NOV.2019 09:37:55

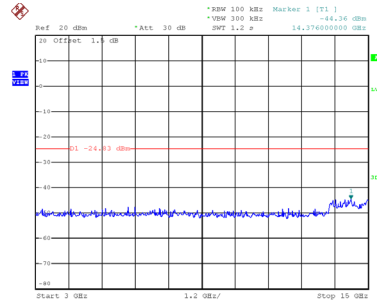

Date: 25.NOV.2019 09:38:03

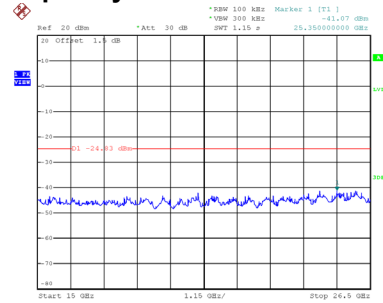

Date: 25.NOV.2019 09:38:11

### CH11 – 10th Harmonic of the fundamental frequency

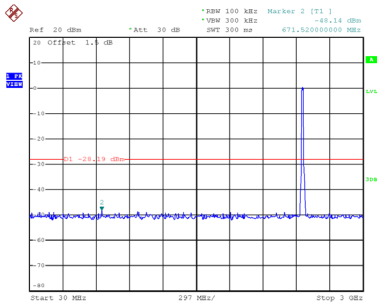

Date: 25.NOV.2019 09:40:54

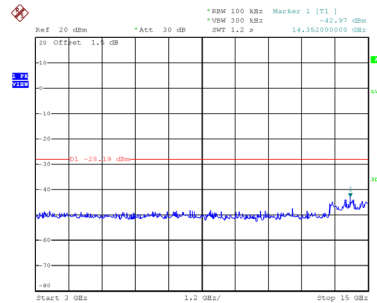

Date: 25.NOV.2019 09:41:02

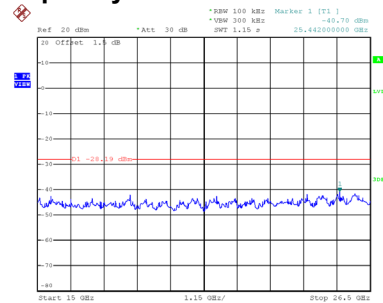

Date: 25.NOV.2019 09:41:10



## APPENDIX H - POWER SPECTRAL DENSITY

Test Mode	TX B Mode
-----------	-----------

Channel	Frequency (MHz)	Power Spectral Density (dBm/3kHz)	Max. Limit (dBm/3kHz)	Result
01	2412	-7.94	8	Complies
06	2437	-7.91	8	Complies
11	2462	-7.19	8	Complies

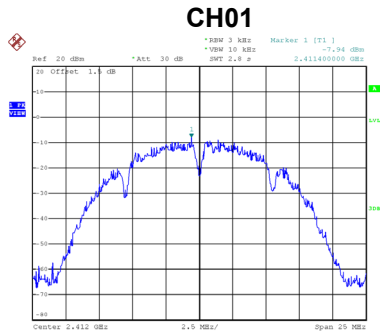

Date: 25.NOV.2019 09:20:49

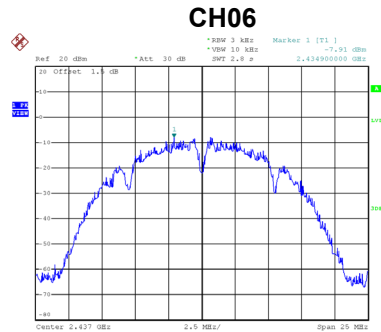

Date: 25.NOV.2019 09:49:12

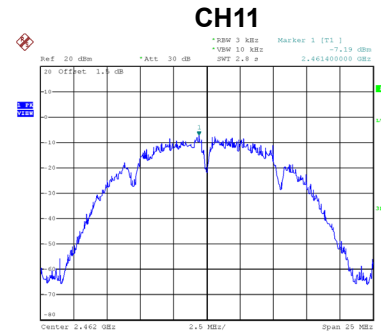

Date: 25.NOV.2019 09:12:102

Test Mode	TX G Mode
-----------	-----------

Channel	Frequency (MHz)	Power Spectral Density (dBm/3kHz)	Max. Limit (dBm/3kHz)	Result
01	2412	-11.39	8	Complies
06	2437	-8.53	8	Complies
11	2462	-12.54	8	Complies

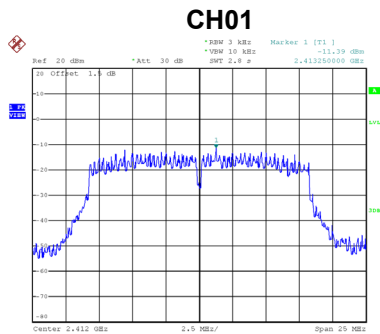

Date: 25.NOV.2019 09:29:00

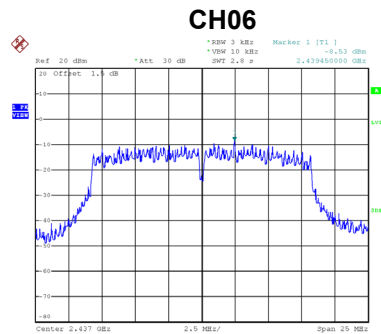

Date: 25.NOV.2019 09:30:26

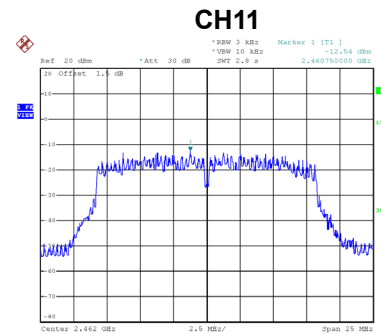

Date: 25.NOV.2019 09:32:12

Test Mode	TX N-20M Mode
-----------	---------------

Channel	Frequency (MHz)	Power Spectral Density (dBm/3kHz)	Max. Limit (dBm/3kHz)	Result
01	2412	-12.72	8	Complies
06	2437	-10.46	8	Complies
11	2462	-13.29	8	Complies

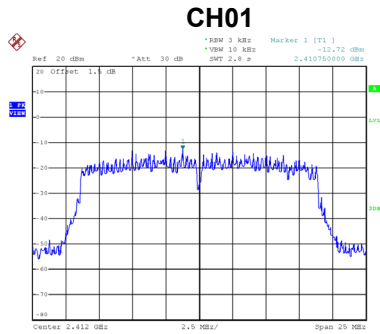

Date: 25.NOV.2019 09:46:26

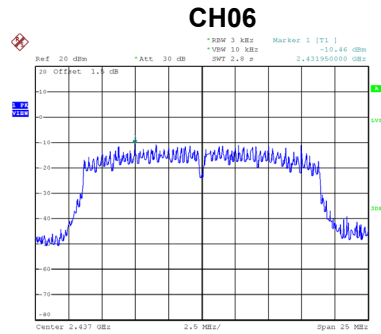

Date: 25.NOV.2019 09:37:16

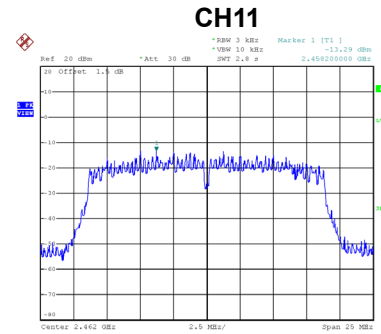

Date: 25.NOV.2019 09:40:16

**End of Test Report**