

www.gsmoutdoors.com



GSM, LLC

PO Box 535189, Grand Prairie, TX 75053-5189

Toll Free: 877-269-8490

REMOTE BEACON ILLUMINATOR



MUD-RBI

USER MANUAL

IC STATEMENT

This device complies with Canada ICES-005(B)/NMB-005(B)

This device contains license-exempt transmitter(s)/receiver(s) that comply with Innovation, Science and Economic Development Canada's license-exempt RSS(s). Operation is subject to the following two conditions:

(1) This device may not cause interference; and

(2) This device must accept any interference, including interference that may cause undesired operation of the device.

Cet appareil contient des émetteurs / récepteurs exemptés de licence conformes aux RSS (RSS) d'Innovation, Sciences et Développement économique Canada. L'exploitation est autorisée aux deux conditions suivantes :

(1) l'appareil ne doit pas produire de brouillage, et

(2) l'utilisateur de l'appareil doit accepter tout brouillage radio électrique subi, même si le brouillage est susceptible d'en compromettre le fonctionnement.

INCLUDED ITEMS

1. Remote Beacon Illuminator (RBI) Unit
2. Remote Activator
3. Mounting Clamp
4. Clamp Spacers
5. User Manual
6. AA 1.5V Battery (x4, for RBI unit)
7. CR2032 3V Lithium Battery (in remote)

ABOUT

The Remote Beacon Indicator (RBI) is intended to be mounted to a tree stand to illuminate the tree stand steps for safety. It can also assist in locating a well-hidden tree stand.

FCC STATEMENT

This device complies with part 15 of the FCC Rules. Operation is subject to the following two conditions: (1) This device may not cause harmful interference, and (2) this device must accept any interference received, including interference that may cause undesired operation. Changes or modifications to the device could void the warranty and the user's authority to operate the device.

RF warning statement: The device has been evaluated to meet general RF exposure requirement. The device can be used in portable exposure condition without restriction.

NOTE: This equipment has been tested and found to comply with the limits for a Class B digital device, pursuant to part 15 of the FCC Rules. These limits are designed to provide reasonable protection against harmful interference in a residential installation. This equipment generates, uses and can radiate radio frequency energy and, if not installed and used in accordance with the instructions, may cause harmful interference to radio communications. However, there is no guarantee that interference will not occur in a particular installation. If this equipment does cause harmful interference to radio or television reception, which can be determined by turning the equipment off and on, the user is encouraged to try to correct the interference by one or more of the following measures:

- Reorient or relocate the receiving antenna.
- Increase the separation between the equipment and receiver.
- Connect the equipment into an outlet on a circuit different from that to which the receiver is connected.
- Consult the dealer or an experienced radio/TV technician for help.

WARNINGS & DISCLOSURES

1. Batteries included are not rechargeable. Trying to recharge can cause damage to battery and unit.
2. If handled improperly, the battery may break or leak causing possible corrosion of the device or clothes.
3. It is recommended that the same model battery is used for battery replacement.
4. Batteries should not come into contact with other metal objects, such as: keys, coins, etc. as this may cause the battery to overheat or short circuit.

Warning! For California Customers: Proposition 65 Warning. This product contains chemicals known to the State of California to cause cancer and birth defects or other reproductive harm. www.p65warning.ca.gov



PRODUCT IDENTIFICATION

1. Battery Compartment
2. Clamp
3. Clamp Spacers
4. LED
5. Power/Pairing Button

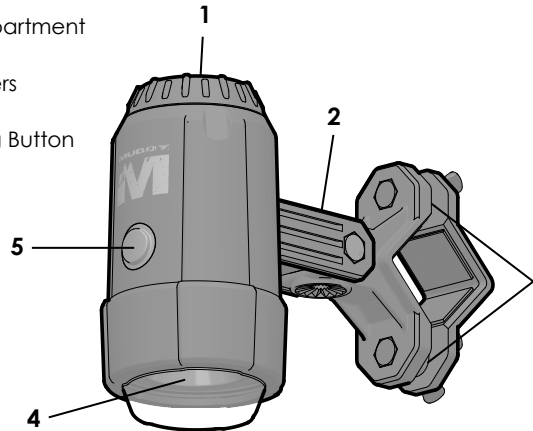

SETUP

Installing batteries

Remove battery cap by turning the cap clockwise.

Insert the included AA batteries in the proper orientation (refer to (+) and (-) marks on the RBI).

Reinstall the battery cap by turning clockwise.



WARRANTY

This MUDDY product is covered by a one-year limited warranty. This warranty covers product with manufacturer defects. Normal wear & tear as well as product abuse are not covered by the warranty. The warranty is valid only for the original owner of the product purchased from an authorized retailer.

Tampering with or altering the unit will void the warranty. Any unauthorized service will void the warranty. Original sales receipt must be produced for any warranty service and a Return Authorization (RA) number must be obtained from customer service at **877-269-8490** prior to returning the product.

For more information go to www.gomuddy.com

OPERATION

Pressing the button on the RBI remote will cause all paired RBI units within range to illuminate.

The remote activator functions at a range of up to 150 yards.

The light on the RBI units will turn off automatically after 3 minutes.

Light may be turned off manually by pressing the button on the RBI unit.

REMOTE PAIRING

The remote activator can be paired to additional RBI units by following these steps:

1. With RBI unit OFF, press and hold the power button until main light begins to flash.
2. Once flashing, press the button on the remote.
3. The light on the RBI unit will turn solid when paired.

(Note: 1 remote activator can be paired with multiple RBI units)

INSTALLATION

The RBI is designed for installation on square tubing used on MUDDY brand tree stands ($\frac{3}{4}$ " – 1"; 20-25mm)

The RBI will also clamp onto round tubing ($\frac{3}{4}$ " – 1"; 20-25mm)

Add or remove clamp spacers (included) as needed)

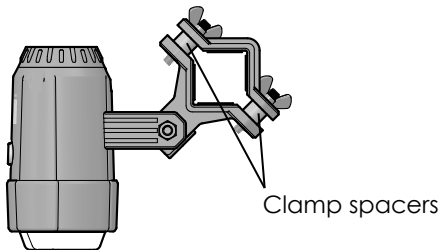

CLAMP ADJUSTMENT

Adjustable clamp can be mounted on horizontal or vertical tubing, with a wide range of adjustments possible in either orientation.

Remove the center thumbscrew to change the orientation of the clamp.

