

FCC Test Report

Report No.: RWAZ202300123E

Applicant: Shenzhen Youmi Intelligent Technology Co., Ltd.

Address: 406-407 Jinqi Zhigu Building, 4/F, 1 Tangling Road, Nanshan District, Shenzhen City, China

Product Name: Smart phone

Product Model: PG3N BG7YA

Multiple Models: N/A

Trade Mark: UMIDIGI

FCC ID: 2ATZ4-G7

Standards: FCC CFR Title 47 Part 2, 22H, 24E, 27

Test Date: 2024-01-10~2024-03-13

Test Result: Complied

Issue Date: 2024-03-13

Reviewed by: *Abel chen*

Approved by: *Jacob Kong*

Abel Chen
Project Engineer

Jacob Kong
Manager

Prepared by:

World Alliance Testing and Certification (Shenzhen) Co., Ltd

No. 1002, East Block, Laobing Building, Xingye Road 3012, Xixiang street, Bao'an District, Shenzhen, Guangdong, People's Republic of China



This report may contain data that are not covered by the NVLAP accreditation and shall be marked with an asterisk “★”

Announcement

1. This test report shall not be reproduced in full or partial, without the written approval of World Alliance Testing and Certification (Shenzhen) Co., Ltd
2. The results in this report apply only to the sample tested.
3. This sample tested is in compliance with the limits of the above regulation.
4. This report must not be used by the client to claim product certification, approval, or endorsement by NVLAP, NIST, or any agency of the U.S. Government.
5. The information marked “#” is provided by the applicant, the laboratory is not responsible for its authenticity and this information can affect the validity of the result in the test report. Customer model name, addresses, names, trademarks etc. are included.

Revision History

Version No.	Issued Date	Description
00	2024-03-13	Original

Contents

1	General Information	4
1.1	Client Information	4
1.2	Product Description of EUT	4
1.3	Related Submittal(s)/Grant(s).....	5
1.4	Measurement Uncertainty	5
1.5	Laboratory Location.....	5
1.6	Test Methodology	5
2	Description of Measurement.....	6
2.1	Test Frequency of Low/Middle/High Channels.....	6
2.2	Test Configuration for LTE bands	6
2.3	Test Auxiliary Equipment	7
2.4	Test Setup.....	8
2.5	Test Procedure.....	10
2.6	Measurement Method.....	11
2.7	Measurement Equipment	12
3	Test Results	13
3.1	Test Summary.....	13
3.2	Limit	14
3.3	RF Conducted Test Data	19
3.3.1	RF Output Power&ERP/EIRP	19
3.3.2	Peak-to-average ratio (PAR)	31
3.3.3	26dB and 99% Bandwidth	33
3.3.4	Conducted Spurious Emissions.....	37
3.3.5	Out of band emission, Band Edge.....	37
3.3.6	FREQUENCY STABILITY	38
3.4	Radiated Spurious emission Test Data.....	46
4	Test Setup Photo.....	55
5	E.U.T Photo.....	56

1 General Information

1.1 Client Information

Applicant:	Shenzhen Youmi Intelligent Technology Co., Ltd.
Address:	406-407 Jinqi Zhigu Building, 4/F, 1 Tangling Road, Nanshan District, Shenzhen City, China
Manufacturer:	Shenzhen Youmi Intelligent Technology Co., Ltd.
Address:	406-407 Jinqi Zhigu Building, 4/F, 1 Tangling Road, Nanshan District, Shenzhen City, China

1.2 Product Description of EUT

The EUT is Smart phone that contains Classic Bluetooth(BDR/EDR), BLE, 2.4G/5G WLAN, GSM/GPRS/WCDMA/LTE and NFC radios, this report covers the full testing of the GSM/GPRS/WCDMA/LTE radios.

Sample Serial number	36-2 for CE&RE test, 36-1 for RF test conducted test (assigned by WATC)				
Sample Received Date	2023-12-15				
Sample Status	Good Condition				
Frequency Range	Band	TX Frequency (MHz)	RX Frequency (MHz)	Max. Conducted Power (dBm)	Antenna Gain [#] (dBi)
Maximum Conducted Power	GSM850	824-849	869-894	32.38	-2.53
Antenna Gain	PCS1900	1850-1910	1920-1980	30.26	0.87
	WCDMA B2	1850-1910	1920-1980	22.70	0.87
	WCDMA B5	824-849	869-894	22.99	-2.53
	LTE B2	1850-1910	1920-1980	23.20	0.87
	LTE B5	824-849	869-894	23.12	-2.53
	LTE B7	2500-2570	2620-2690	23.06	-1.49
	LTE B12	699-716	729-746	23.51	-2.9
	LTE B41	2535-2655	2535-2655	23.70	-1.59
Modulation Technology	GMSK, BPSK, QPSK, 16QAM				
Power Supply	DC 3.87V from battery or DC 5V from adapter				
Adapter 1 Information	Model: HF-0502000U Input: AC 100-240V~50/60Hz, 0.3A Output: DC 5.0V, 2.0A				
Adapter 2 Information	Model: HJ-0502000W2-US Input: AC 100-240V~50/60Hz, 0.3A Output: DC 5.0V, 2.0A				
Modification	Sample No Modification by the test lab				

1.3 Related Submittal(s)/Grant(s)

FCC Part 15, Subpart C, Equipment Class: DSS, FCC ID: 2ATZ4-G7
FCC Part 15, Subpart C, Equipment Class: DTS, FCC ID: 2ATZ4-G7
FCC Part 15, Subpart C, Equipment Class: DXX, FCC ID: 2ATZ4-G7
FCC Part 15, Subpart E, Equipment Class: NII, FCC ID: 2ATZ4-G7

1.4 Measurement Uncertainty

Parameter		Expanded Uncertainty (Confidence of 95%(U = 2Uc(y)))
Emissions, Radiated	Below 30MHz	±2.78dB
	Below 1GHz	±4.84dB
	Above 1GHz	±5.44dB
Emissions, Conducted		1.75dB
Conducted Power		0.74dB
Frequency Error		150Hz
Bandwidth		0.34%

Note 1: The extended uncertainty given in this report is obtained by combining the standard uncertainty times the coverage factor K with the 95% confidence interval. Otherwise required by the applicant or Product Regulations, Decision Rule in this report did not consider the uncertainty.

Note 2: The Decision Rule is based on simple acceptance with ISO Guide 98-4:2012 Clause 8.2 (Measurement uncertainty is not taken into account when stating conformity with a specified requirement.)

1.5 Laboratory Location

<p>World Alliance Testing and Certification (Shenzhen) Co., Ltd</p> <p>No. 1002, East Block, Laobing Building, Xingye Road 3012, Xixiang street, Bao'an District, Shenzhen, Guangdong, People's Republic of China</p> <p>Tel: +86-755-29691511, Email: qa@watc.com.cn</p> <p>The lab has been recognized as the FCC accredited lab under the KDB 974614 D01 and is listed in the FCC Public Access Link (PAL) database, FCC Registration No. : 463912, the FCC Designation No. : CN5040.</p> <p>The lab has been recognized by Innovation, Science and Economic Development Canada to test to Canadian radio equipment requirements, the CAB identifier: CN0160.</p>
--

1.6 Test Methodology

FCC CFR Title 47 Part 2, 22H, 24E, 27

ANSI C63.26-2015

FCC KDB 971168 D01 Power Meas License Digital Systems v03r01

FCC KDB 412172 D01 Determining ERP and EIRP v01r01

2 Description of Measurement

2.1 Test Frequency of Low/Middle/High Channels

Band	Bandwidth (MHz)	Low Channel (MHz)	Middle Channel (MHz)	High Channel (MHz)
GSM850	0.2	824.2	836.6	848.8
PCS1900	0.2	1850.2	1880	1909.8
WCDMA B2	4.8	1852.4	1880	1907.6
WCDMA B5	4.8	826.4	836.6	846.6
LTE B2	1.4	1850.7	1880	1909.3
	3	1851.5	1880	1908.5
	5	1852.5	1880	1907.5
	10	1855	1880	1905
	15	1857.5	1880	1902.5
	20	1860	1880	1900
LTE B5	1.4	824.7	836.5	848.3
	3	825.5	836.5	847.5
	5	826.5	836.5	846.5
	10	829	836.5	844
LTE B7	5	2502.5	2535	2567.5
	10	2505	2535	2565
	15	2507.5	2535	2562.5
	20	2510	2535	2560
LTE B12	1.4	699.7	707.5	715.3
	3	700.5	707.5	714.5
	5	701.5	707.5	713.5
	10	704	707.5	711
LTE B41	5	2537.5	2595	2652.5
	10	2540	2595	2650
	15	2542.5	2595	2647.5
	20	2545	2595	2645

2.2 Test Configuration for LTE bands

Test Items	Band	Bandwidth (MHz)						Modulation		RB#			Test Channel		
		1.4	3	5	10	15	20	QPSK	16QAM	1	Half	Full	L	M	H
RF Output Power ERP/EIRP	2	√	√	√	√	√	√	√	√	√	√	√	√	√	√
	5	√	√	√	√	-	-	√	√	√	√	√	√	√	√
	7	-	-	√	√	√	√	√	√	√	√	√	√	√	√
	12	√	√	√	√	-	-	√	√	√	√	√	√	√	√
	41	-	-	√	√	√	√	√	√	√	√	√	√	√	√
Peak-to-Average Ratio	2						√	√	√	√		√	√	√	√
	5				√	-	-	√	√	√		√	√	√	√
	7	-	-				√	√	√	√		√	√	√	√
	12				√	-	-	√	√	√		√	√	√	√
	41	-	-				√	√	√	√		√	√	√	√
26dB and 99% Bandwidth	2	√	√	√	√	√	√	√	√			√		√	
	5	√	√	√	√	-	-	√	√			√		√	
	7	-	-	√	√	√	√	√	√			√		√	
	12	√	√	√	√	-	-	√	√			√		√	
	41	-	-	√	√	√	√	√	√			√		√	

Band Edge	2	√	√	√	√	√	√	√	√	√	√	√	√	√	√
	5	√	√	√	√	-	-	√	√	√	√	√	√	√	√
	7	-	-	√	√	√	√	√	√	√	√	√	√	√	√
	12	√	√	√	√	-	-	√	√	√	√	√	√	√	√
	41	-	-	√	√	√	√	√	√	√	√	√	√	√	√
Conducted Spurious Emission	2	√	√	√	√	√	√	√	√	√	√	√	√	√	√
	5	√	√	√	√	-	-	√	√	√	√	√	√	√	√
	7	-	-	√	√	√	√	√	√	√	√	√	√	√	√
	12	√	√	√	√	-	-	√	√	√	√	√	√	√	√
	41	-	-	√	√	√	√	√	√	√	√	√	√	√	√
Frequency Stability	2				√			√	√			√	√		√
	5				√	-	-	√	√			√		√	
	7	-	-		√			√	√			√	√		√
	12				√	-	-	√	√			√	√		√
	41	-	-		√			√	√			√	√		√
Radiated Spurious Emission	2	√						√		√			√	√	√
	5	√				-	-	√		√			√	√	√
	7	-	-	√				√		√			√	√	√
	12	√				-	-	√		√			√	√	√
	41	-	-	√				√		√			√	√	√

Note:

1. "√" means the configuration was chosen for testing
2. "-" means the not support the bandwidth

Worst-Case Configuration:

For radiated emissions, EUT was investigated in three orthogonal orientation, the worst-case orientation was recorded in report

For radiated emissions, measurement was investigated from 30MHz to 10 times of fundamental, the worst case bandwidth, RB size and modulation test data was recorded.

2.3 Test Auxiliary Equipment

Manufacturer	Description	Model	Serial Number
/	/	/	/

2.4 Test Setup

1) Radiated emission measurement:

30MHz-1GHz (3m SAC)

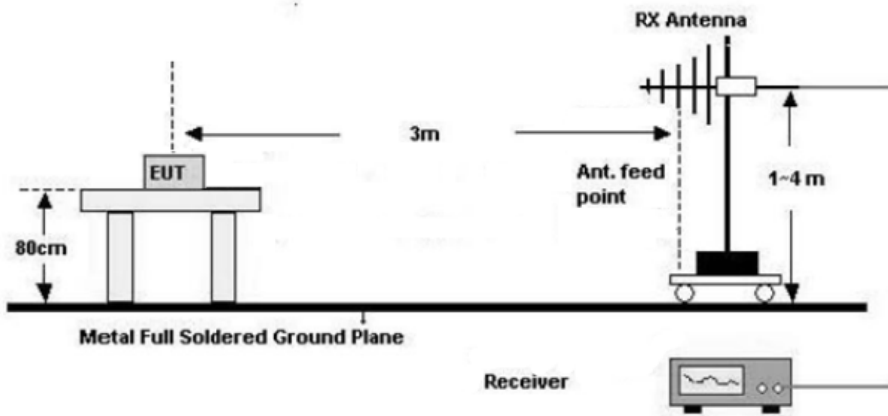

Above 1GHz (3m FAC)

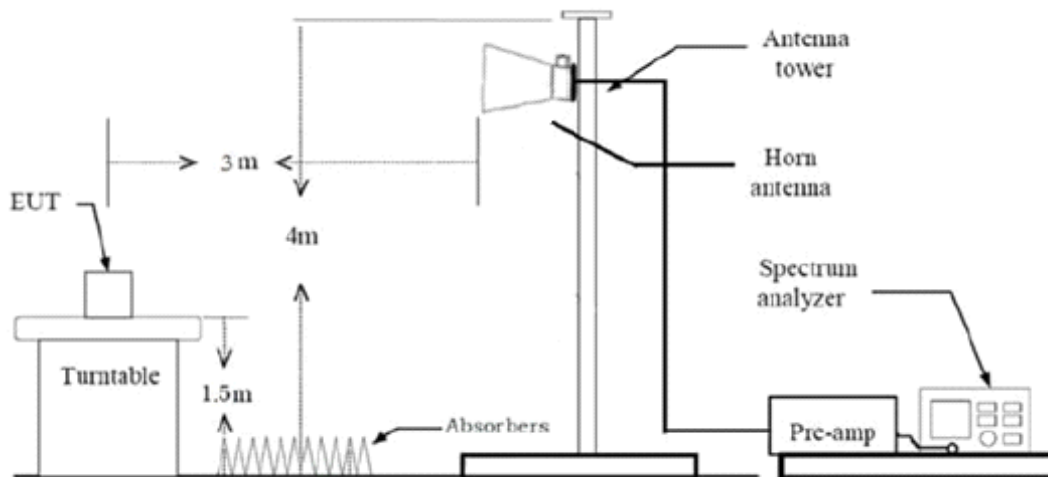

2) RF Conducted Test

For RF Output Power test

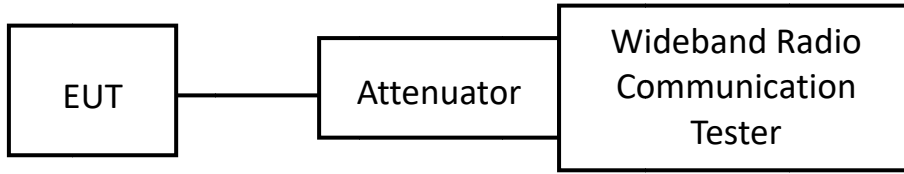

For Bandwidth/Band edge/ PAR/Conducted spurious emissions Test

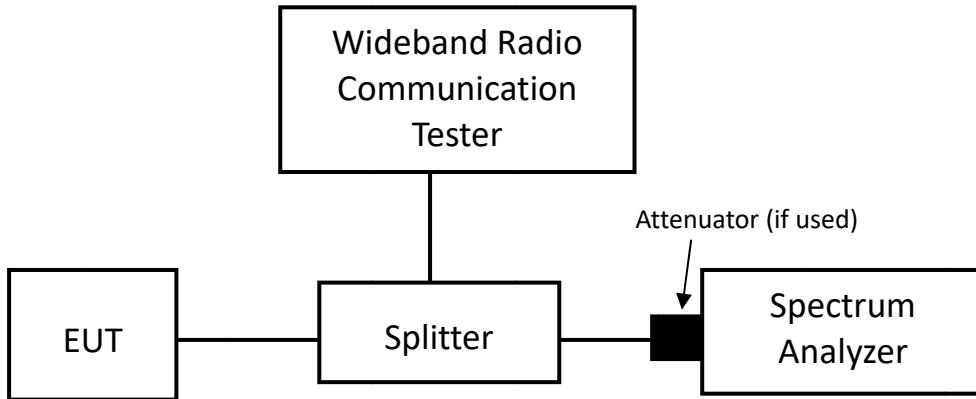

For Frequency Stability test

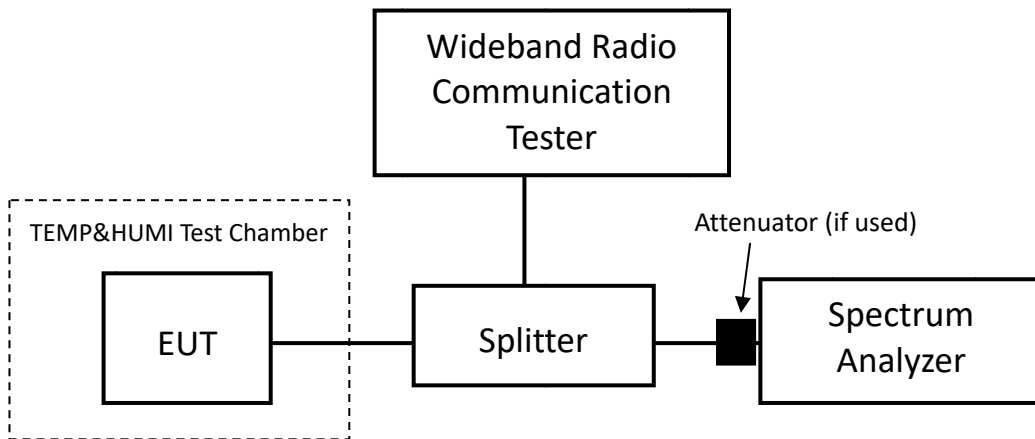

2.5 Test Procedure

Radiated Emission Procedure:

a) For 30MHz-1GHz:

1. The EUT was placed on the tabletop of a rotating table 0.8 m the ground at a 3 m semi anechoic chamber. The measurement distance from the EUT to the receiving antenna is 3 m.
2. EUT works in each mode of operation that needs to be tested. The highest signal levels relative to the limit shall be determined by rotating the EUT from 0° to 360° and with varying the measurement antenna height between 1 m and 4 m in vertical and horizontal polarizations.

b) For above 1GHz:

1. The EUT was placed on the tabletop of a rotating table 1.5 m the ground at a 3 m fully anechoic room. The measurement distance from the EUT to the receiving antenna is 3 m.
2. EUT works in each mode of operation that needs to be tested, and having the EUT continuously working. The highest signal levels relative to the limit shall be determined by rotating the EUT from 0° to 360° and with varying the measurement antenna height between 1 m and 4 m in vertical and horizontal polarizations.
3. Open the test software to control the test antenna and test turntable. Perform the test, save the test results, and export the test data.

RF Conducted Test:

1. The antenna port of EUT was connected to the RF port of the test equipment (Wideband Radio Communication Tester or Spectrum analyzer) through Attenuator and RF cable.
2. The cable assembly insertion loss (including Splitter, attenuator and cable loss) was entered as an offset in the power meter. Note: Actual cable loss was unavailable at the time of testing, therefore the loss used was assumed as worst case. This was later verified to be true by laboratory. (if the RF cable provided by client, the cable loss declared by client)
3. The EUT is keeping in continuous transmission mode and tested in all modulation modes.

2.6 Measurement Method

Description of Test	Measurement Method
RF Output Power	ANSI C63.26-2015 section 5.2
ERP/EIRP	ANSI C63.26-2015 section 5.2.5.5
Peak-to-Average Ratio	ANSI C63.26-2015 section 5.2.3.4
26dB and 99% Bandwidth	ANSI C63.26-2015 section 5.4
Band Edge	ANSI C63.26-2015 section 5.7.3
Conducted Spurious Emissions	ANSI C63.26-2015 section 5.7.4
Frequency Stability	ANSI C63.26-2015 section 5.6
Radiated Spurious Emissions	ANSI C63.26-2015 section 5.5.4

2.7 Measurement Equipment

Manufacturer	Description	Model	Management No.	Calibration Date	Calibration Due Date
Radiated Emission Test					
R&S	EMI test receiver	ESR3	102758	2023/7/3	2024/7/2
ROHDE& SCHWARZ	SPECTRUM ANALYZER	FSV40-N	101608	2023/7/3	2024/7/2
SONOMA INSTRUMENT	Low frequency amplifier	310	186014	2023/7/12	2024/7/11
COM-POWER	preamplifier	PAM-118A	18040152	2023/8/21	2024/8/20
COM-POWER	Amplifier	PAM-840A	461306	2023/8/8	2024/8/7
SCHWARZBECK	Log - periodic wideband antenna	VULB 9163	9163-872	2023/7/7	2024/7/6
Astro Antenna Ltd	Horn antenna	AHA-118S	3015	2023/7/6	2024/7/5
Ducommun technologies	Horn Antenna	ARH-4223-02	1007726-03	2023/7/10	2024/7/9
Ducommun technologies	Horn Antenna	ARH-2823-02	1007726-03	2023/7/10	2024/7/9
N/A	Coaxial Cable	N/A	NO.9	2023/8/8	2024/8/7
N/A	Coaxial Cable	N/A	NO.10	2023/8/8	2024/8/7
N/A	Coaxial Cable	N/A	NO.11	2023/8/8	2024/8/7
Audix	Test Software	E3	191218 V9	/	/
RF Conducted Test					
R&S	Spectrum Analyzer	FSV40	101419	2023/9/12	2024/9/11
R&S	Sepctrum Analyzer	FSU	200982	2023/10/25	2024/10/24
MARCONI	10dB Attenuator	1692595	2942	2023/10/25	2024/10/24
HP	Power Splitter	11667A	1610A	2023/7/26	2024/7/25
R&S	Wideband Radio Communication tester	CMW500	146520	2023/10/25	2024/10/24
BACL	TEMP&HUMI Test Chamber	BTH-150	30022	2023/7/12	2024/7/11
FLUKE	Digital Multimeter	15B+	N/A	2023/7/12	2024/7/11

Note: All equipment is calibrated with valid calibrations. Each measurement data is traceable to the national or International standards.

3 Test Results

3.1 Test Summary

FCC Rules	Description of Test	Result
FCC§2.1046; § 22.913; § 24.232; §27.50	RF Output Power	Compliance
FCC§ 2.1047	Modulation Characteristics	Compliance
FCC§ 2.1049; § 22.905; § 22.917; § 24.238; §27.53;	26dB and 99% Bandwidth	Compliance
FCC§ 2.1051; § 22.917; § 24.238; §27.53	Conducted Spurious Emissions	Compliance
FCC§ 22.917; § 24.238; §27.53	Out of band emission, Band Edge	Compliance
FCC§ 2.1055; § 22.355; § 24.235; §27.54	Frequency stability	Compliance
FCC§ 2.1053; § 22.917; § 24.238; §27.53	Radiated Spurious Emissions	Compliance

3.2 Limit

Test items	Limit																																
RF Output Power	<p>FCC §22.913:</p> <p>(a)(5) The ERP of mobile transmitters and auxiliary test transmitters must not exceed 7watts.</p> <p>(d) Power measurement. Measurement of the ERP of Cellular base transmitters and repeaters must be made using an average power measurement technique. The peak-to average ratio (PAR) of the transmission must not exceed 13 dB. Power measurements for base transmitters and repeaters must be made in accordance with either of the following:</p> <p>(1) A Commission-approved average power technique (see FCC Laboratory's Knowledge Database); or</p> <p>(2) For purposes of this section, peak transmit power must be measured over an interval of continuous transmission using instrumentation calibrated in terms of an rms equivalent voltage. The measurement results shall be properly adjusted for any instrument limitations, such as detector response times, limited resolution bandwidth capability when compared to the emission bandwidth, sensitivity, etc., so as to obtain a true peak measurement for the emission in question over the full bandwidth of the channel.</p>																																
Unwanted Emissions (Out of band emission and spurious)	<p>FCC §22.917:</p> <p>(a) Out of band emissions. The power of any emission outside of the authorized operating frequency ranges must be attenuated below the transmitting power (P) by a factor of at least $43 + 10 \log(P)$ dB.</p> <p>(b) Measurement procedure. Compliance with these rules is based on the use of measurement instrumentation employing a reference bandwidth as follows:</p> <p>(1) In the spectrum below 1 GHz, instrumentation should employ a reference bandwidth of 100 kHz or greater. In the 1 MHz bands immediately outside and adjacent to the frequency block, a resolution bandwidth of at least one percent of the emission bandwidth of the fundamental emission of the transmitter may be employed. A narrower resolution bandwidth is permitted in all cases to improve measurement accuracy, provided that the measured power is integrated over the full required reference bandwidth (i.e., 100 kHz or 1 percent of emission bandwidth, as specified). The emission bandwidth is defined as the width of the signal between two points, one below the carrier center frequency and one above the carrier center frequency, outside of which all emissions are attenuated at least 26 dB below the transmitter power.</p> <p>(2) In the spectrum above 1 GHz, instrumentation should employ a reference bandwidth of 1 MHz</p>																																
Frequency stability	<p>FCC §22.355:</p> <p>Except as otherwise provided in this part, the carrier frequency of each transmitter in the Public Mobile Services must be maintained within the tolerances given in Table C-1 of this section.</p> <div style="border: 1px solid #ccc; padding: 5px; margin: 10px 0;"> <p style="text-align: center; font-size: small;">Table C-1—Frequency Tolerance for Transmitters in the Public Mobile Services</p> <table border="1" style="width: 100%; border-collapse: collapse;"> <thead> <tr> <th style="text-align: center;">Frequency range (MHz)</th> <th style="text-align: center;">Base, fixed (ppm)</th> <th style="text-align: center;">Mobile >3 watts (ppm)</th> <th style="text-align: center;">Mobile ≤3 watts (ppm)</th> </tr> </thead> <tbody> <tr> <td style="text-align: center;">25 to 50</td> <td style="text-align: center;">20.0</td> <td style="text-align: center;">20.0</td> <td style="text-align: center;">50.0</td> </tr> <tr> <td style="text-align: center;">50 to 450</td> <td style="text-align: center;">5.0</td> <td style="text-align: center;">5.0</td> <td style="text-align: center;">50.0</td> </tr> <tr> <td style="text-align: center;">450 to 512</td> <td style="text-align: center;">2.5</td> <td style="text-align: center;">5.0</td> <td style="text-align: center;">5.0</td> </tr> <tr> <td style="text-align: center;">821 to 896</td> <td style="text-align: center;">1.5</td> <td style="text-align: center;">2.5</td> <td style="text-align: center;">2.5</td> </tr> <tr> <td style="text-align: center;">928 to 929</td> <td style="text-align: center;">5.0</td> <td style="text-align: center;">n/a</td> <td style="text-align: center;">n/a</td> </tr> <tr> <td style="text-align: center;">929 to 960</td> <td style="text-align: center;">1.5</td> <td style="text-align: center;">n/a</td> <td style="text-align: center;">n/a</td> </tr> <tr> <td style="text-align: center;">2110 to 2220</td> <td style="text-align: center;">10.0</td> <td style="text-align: center;">n/a</td> <td style="text-align: center;">n/a</td> </tr> </tbody> </table> </div>	Frequency range (MHz)	Base, fixed (ppm)	Mobile >3 watts (ppm)	Mobile ≤3 watts (ppm)	25 to 50	20.0	20.0	50.0	50 to 450	5.0	5.0	50.0	450 to 512	2.5	5.0	5.0	821 to 896	1.5	2.5	2.5	928 to 929	5.0	n/a	n/a	929 to 960	1.5	n/a	n/a	2110 to 2220	10.0	n/a	n/a
Frequency range (MHz)	Base, fixed (ppm)	Mobile >3 watts (ppm)	Mobile ≤3 watts (ppm)																														
25 to 50	20.0	20.0	50.0																														
50 to 450	5.0	5.0	50.0																														
450 to 512	2.5	5.0	5.0																														
821 to 896	1.5	2.5	2.5																														
928 to 929	5.0	n/a	n/a																														
929 to 960	1.5	n/a	n/a																														
2110 to 2220	10.0	n/a	n/a																														

Test items	Limit
RF Output Power	<p>FCC §24.232:</p> <p>(c) Mobile and portable stations are limited to 2 watts EIRP and the equipment must employ a means for limiting power to the minimum necessary for successful communications.</p> <p>(d) Power measurements for transmissions by stations authorized under this section may be made either in accordance with a Commission-approved average power technique or in compliance with paragraph (e) of this section. In both instances, equipment employed must be authorized in accordance with the provisions of § 24.51. In measuring transmissions in this band using an average power technique, the peak-to-average ratio (PAR) of the transmission may not exceed 13 dB.</p>
Unwanted Emissions (Out of band emission and spurious)	<p>FCC §24.238:</p> <p>The rules in this section govern the spectral characteristics of emissions in the Broadband Personal Communications Service.</p> <p>(a) Out of band emissions. The power of any emission outside of the authorized operating frequency ranges must be attenuated below the transmitting power (P) by a factor of at least $43 + 10 \log(P)$ dB.</p> <p>(b) Measurement procedure. Compliance with these rules is based on the use of measurement instrumentation employing a resolution bandwidth of 1 MHz or greater. However, in the 1 MHz bands immediately outside and adjacent to the frequency block a resolution bandwidth of at least one percent of the emission bandwidth of the fundamental emission of the transmitter may be employed. A narrower resolution bandwidth is permitted in all cases to improve measurement accuracy provided the measured power is integrated over the full required measurement bandwidth (i.e. 1 MHz or 1 percent of emission bandwidth, as specified). The emission bandwidth is defined as the width of the signal between two points, one below the carrier center frequency and one above the carrier center frequency, outside of which all emissions are attenuated at least 26 dB below the transmitter power.</p> <p>(c) Alternative out of band emission limit. Licensees in this service may establish an alternative out of band emission limit to be used at specified band edge(s) in specified geographical areas, in lieu of that set forth in this section, pursuant to a private contractual arrangement of all affected licensees and applicants. In this event, each party to such contract shall maintain a copy of the contract in their station files and disclose it to prospective assignees or transferees and, upon request, to the FCC.</p> <p>(d) Interference caused by out of band emissions. If any emission from a transmitter operating in this service results in interference to users of another radio service, the FCC may require a greater attenuation of that emission than specified in this section.</p>
Frequency stability	<p>FCC §24.235:</p> <p>The frequency stability shall be sufficient to ensure that the fundamental emission stays within the authorized frequency block.</p>

Test items	Limit
RF Output Power	<p>FCC §27.50:</p> <p>(a)(3) Mobile and portable stations.</p> <p>(i) For mobile and portable stations transmitting in the 2305-2315 MHz band or the 2350-2360 MHz band, the average EIRP must not exceed 50 milliwatts within any 1 megahertz of authorized bandwidth, except that for mobile and portable stations compliant with 3GPP LTE standards or another advanced mobile broadband protocol that avoids concentrating energy at the edge of the operating band the average EIRP must not exceed 250 milliwatts within any 5 megahertz of authorized bandwidth but may exceed 50 milliwatts within any 1 megahertz of authorized bandwidth. For mobile and portable stations using time division duplexing (TDD) technology, the duty cycle must not exceed 38 percent in the 2305-2315 MHz and 2350-2360 MHz bands. Mobile and portable stations using FDD technology are restricted to transmitting in the 2305-2315 MHz band. Power averaging shall not include intervals in which the transmitter is off.</p> <p>(ii) Mobile and portable stations are not permitted to transmit in the 2315-2320 MHz and 2345-2350 MHz bands.</p> <p>(iii) Automatic transmit power control. Mobile and portable stations transmitting in the 2305-2315 MHz band or in the 2350-2360 MHz band must employ automatic transmit power control when operating so the stations operate with the minimum power necessary for successful communications.</p> <p>(iv) Prohibition on external vehicle-mounted antennas. The use of external vehicle-mounted antennas for mobile and portable stations transmitting in the 2305-2315 MHz band or the 2350-2360 MHz band is prohibited.</p> <p>(b)(10) Portable stations (hand-held devices) transmitting in the 746-757 MHz, 776-788 MHz, and 805-806 MHz bands are limited to 3 watts ERP.</p> <p>(c)(10) Portable stations (hand-held devices) in the 600 MHz uplink band and the 698-746 MHz band, and fixed and mobile stations in the 600 MHz uplink band are limited to 3 watts ERP.</p> <p>(d)(4) Fixed, mobile, and portable (hand-held) stations operating in the 1710-1755 MHz band and mobile and portable stations operating in the 1695-1710 MHz and 1755-1780 MHz bands are limited to 1 watt EIRP. Fixed stations operating in the 1710-1755 MHz band are limited to a maximum antenna height of 10 meters above ground. Mobile and portable stations operating in these bands must employ a means for limiting power to the minimum necessary for successful communications.</p> <p>(h) The following power limits shall apply in the BRS and EBS: (2) Mobile and other user stations. Mobile stations are limited to 2.0 watts EIRP. All user stations are limited to 2.0 watts transmitter output power.</p>

<p>Unwanted Emissions (Out of band emission and spurious)</p>	<p>FCC §27.53:</p> <p>(a) For operations in the 2305-2320 MHz band and the 2345-2360 MHz band, the power of any emission outside a licensee's frequency band(s) of operation shall be attenuated below the transmitter power P (with averaging performed only during periods of transmission) within the licensed band(s) of operation, in watts, by the following amounts:</p> <p>(4) For mobile and portable stations operating in the 2305-2315 MHz and 2350-2360 MHz bands:</p> <p>(i) By a factor of not less than: $43 + 10 \log (P)$ dB on all frequencies between 2305 and 2320 MHz and on all frequencies between 2345 and 2360 MHz that are outside the licensed band(s) of operation, not less than $55 + 10 \log (P)$ dB on all frequencies between 2320 and 2324 MHz and on all frequencies between 2341 and 2345 MHz, not less than $61 + 10 \log (P)$ dB on all frequencies between 2324 and 2328 MHz and on all frequencies between 2337 and 2341 MHz, and not less than $67 + 10 \log (P)$ dB on all frequencies between 2328 and 2337 MHz;</p> <p>(ii) By a factor of not less than $43 + 10 \log (P)$ dB on all frequencies between 2300 and 2305 MHz, $55 + 10 \log (P)$ dB on all frequencies between 2296 and 2300 MHz, $61 + 10 \log (P)$ dB on all frequencies between 2292 and 2296 MHz, $67 + 10 \log (P)$ dB on all frequencies between 2288 and 2292 MHz, and $70 + 10 \log (P)$ dB below 2288 MHz;</p> <p>(iii) By a factor of not less than $43 + 10 \log (P)$ dB on all frequencies between 2360 and 2365 MHz, and not less than $70 + 10 \log (P)$ dB above 2365 MHz.</p> <p>(c) For operations in the 746-758 MHz band and the 776-788 MHz band, the power of any emission outside the licensee's frequency band(s) of operation shall be attenuated below the transmitter power (P) within the licensed band(s) of operation, measured in watts, in accordance with the following:</p> <p>(1) On any frequency outside the 746-758 MHz band, the power of any emission shall be attenuated outside the band below the transmitter power (P) by at least $43 + 10 \log (P)$ dB;</p> <p>(2) On any frequency outside the 776-788 MHz band, the power of any emission shall be attenuated outside the band below the transmitter power (P) by at least $43 + 10 \log (P)$ dB;</p> <p>(3) On all frequencies between 763-775 MHz and 793-805 MHz, by a factor not less than $76 + 10 \log (P)$ dB in a 6.25 kHz band segment, for base and fixed stations;</p> <p>(4) On all frequencies between 763-775 MHz and 793-805 MHz, by a factor not less than $65 + 10 \log (P)$ dB in a 6.25 kHz band segment, for mobile and portable stations;</p> <p>(5) Compliance with the provisions of paragraphs (c)(1) and (c)(2) of this section is based on the use of measurement instrumentation employing a resolution bandwidth of 100 kHz or greater. However, in the 100 kHz bands immediately outside and adjacent to the frequency block, a resolution bandwidth of at least 30 kHz may be employed;</p> <p>(6) Compliance with the provisions of paragraphs (c)(3) and (c)(4) of this section is based on the use of measurement instrumentation such that the reading taken with any resolution bandwidth setting should be adjusted to indicate spectral energy in a 6.25 kHz segment.</p>
--	---

	<p>(f) For operations in the 746-758 MHz, 775-788 MHz, and 805-806 MHz bands, emissions in the band 1559-1610 MHz shall be limited to -70 dBW/MHz equivalent isotropically radiated power (EIRP) for wideband signals, and -80 dBW EIRP for discrete emissions of less than 700 Hz bandwidth. For the purpose of equipment authorization, a transmitter shall be tested with an antenna that is representative of the type that will be used with the equipment in normal operation.</p> <p>(g) For operations in the 600 MHz band and the 698-746 MHz band, the power of any emission outside a licensee's frequency band(s) of operation shall be attenuated below the transmitter power (P) within the licensed band(s) of operation, measured in watts, by at least $43 + 10 \log (P)$ dB. Compliance with this provision is based on the use of measurement instrumentation employing a resolution bandwidth of 100 kilohertz or greater. However, in the 100 kilohertz bands immediately outside and adjacent to a licensee's frequency block, a resolution bandwidth of at least 30 kHz may be employed.</p> <p>(h) AWS emission limits (1) <i>General protection levels.</i> Except as otherwise specified below, for operations in the 1695-1710 MHz, 1710-1755 MHz, 1755-1780 MHz, 1915-1920 MHz, 1995-2000 MHz, 2000-2020 MHz, 2110-2155 MHz, 2155-2180 MHz, and 2180-2200 bands, the power of any emission outside a licensee's frequency block shall be attenuated below the transmitter power (P) in watts by at least $43 + 10 \log_{10} (P)$ dB.</p> <p>(m)(4) For mobile digital stations, the attenuation factor shall be not less than $40 + 10 \log (P)$ dB on all frequencies between the channel edge and 5 megahertz from the channel edge, $43 + 10 \log (P)$ dB on all frequencies between 5 megahertz and X megahertz from the channel edge, and $55 + 10 \log (P)$ dB on all frequencies more than X megahertz from the channel edge, where X is the greater of 6 megahertz or the actual emission bandwidth as defined in paragraph (m)(6) of this section. In addition, the attenuation factor shall not be less than $43 + 10 \log (P)$ dB on all frequencies between 2490.5 MHz and 2496 MHz and $55 + 10 \log (P)$ dB at or below 2490.5 MHz. Mobile Satellite Service licensees operating on frequencies below 2495 MHz may also submit a documented interference complaint against BRS licensees operating on channel BRS Channel 1 on the same terms and conditions as adjacent channel BRS or EBS licensees.</p>
Frequency stability	<p>FCC §27.54:</p> <p>The frequency stability shall be sufficient to ensure that the fundamental emissions stay within the authorized bands of operation.</p>

3.3 RF Conducted Test Data

Test Date:	2024-01-10~2024-03-13	Test By:	Ryan Zhang
Environment condition:	Temperature: 25~26.5°C; Relative Humidity: 48~50%; ATM Pressure: 101~101.2kPa		

3.3.1 RF Output Power&ERP/EIRP

Cellular Band

Test Mode	Conducted Peak Output Power(dBm)			Maximum ERP (dBm)	ERP Limit (dBm)
	Lowest Channel	Middle Channel	Highest Channel		
GSM	32.3	32.23	32.38	27.7	38.45
GPRS 1 Slot	32.16	32.19	32.3	27.62	38.45
GPRS 2 Slots	30.34	30.19	30.16	25.66	38.45
GPRS 3 Slots	28.21	28.38	28.3	23.7	38.45
GPRS 4 Slots	26.19	26.42	26.33	21.74	38.45

Note: ERP=Conducted Power(dBm) - LC(dB) + GT(dBd)
GT=-2.53dBi=-4.68dBd(0dBi=2.15dBd), LC=0dB

Test Mode	Conducted Average Output Power(dBm)			Maximum ERP (dBm)	ERP Limit (dBm)
	Lowest Channel	Middle Channel	Highest Channel		
WCDMA R99	22.95	22.99	22.91	18.31	38.45
HSDPA Subtest 1	21.66	21.5	21.61	16.98	38.45
HSDPA Subtest 2	21.45	21.49	21.48	16.81	38.45
HSDPA Subtest 3	21.23	21.15	21.29	16.61	38.45
HSDPA Subtest 4	21.51	21.57	21.47	16.89	38.45
HSUPA Subtest 1	21.24	21.16	21.14	16.56	38.45
HSUPA Subtest 2	20.16	20.19	20.26	15.58	38.45
HSUPA Subtest 3	20.2	20.22	20.01	15.54	38.45
HSUPA Subtest 4	20.14	20.27	20.01	15.59	38.45
HSUPA Subtest 5	20.15	20.28	20.17	15.6	38.45

Note: ERP=Conducted Power(dBm) - LC(dB) + GT(dBd)
GT=-2.53dBi=-4.68dBd(0dBi=2.15dBd), LC=0dB

PCS Band

Test Mode	Conducted Peak Output Power(dBm)			Maximum EIRP (dBm)	EIRP Limit (dBm)
	Lowest Channel	Middle Channel	Highest Channel		
GSM	30.21	30.14	30.26	31.13	33
GPRS 1 Slot	29.02	29.18	29.01	30.05	33
GPRS 2 Slots	27	27.2	27.28	28.15	33
GPRS 3 Slots	25.3	25.24	25.04	26.17	33
GPRS 4 Slots	23.12	23.19	23.07	24.06	33
Note: EIRP=Conducted Power(dBm) - LC(dB) + GT(dBi) GT=0.87dBi, LC=0dB					

Test Mode	Conducted Average Output Power(dBm)			Maximum EIRP (dBm)	EIRP Limit (dBm)
	Lowest Channel	Middle Channel	Highest Channel		
WCDMA R99	22.6	22.61	22.7	23.57	33
HSDPA Subtest 1	21.57	21.55	21.68	22.55	33
HSDPA Subtest 2	21.04	21.28	21.12	22.15	33
HSDPA Subtest 3	21.05	21.12	21.19	22.06	33
HSDPA Subtest 4	21.04	21.03	21.24	22.11	33
HSUPA Subtest 1	21.26	21.24	21.06	22.13	33
HSUPA Subtest 2	20.12	20.14	20.07	21.01	33
HSUPA Subtest 3	20	20.24	20.26	21.13	33
HSUPA Subtest 4	20.29	20.05	20.18	21.16	33
HSUPA Subtest 5	20.07	20.15	20.06	21.02	33
Note: EIRP=Conducted Power(dBm) - LC(dB) + GT(dBi) GT=0.87dBi, LC=0dB					

LTE Band 2

Test Bandwidth & Modulation	Resource Block & RB offset	Conducted Average Output Power(dBm)			Maximum EIRP (dBm)	EIRP Limit (dBm)
		Lowest Channel	Middle Channel	Highest Channel		
1.4MHz QPSK	RB1#0	22.5	22.67	22.97	23.99	33
	RB1#3	22.7	22.86	23.12		
	RB1#5	22.49	22.68	22.94		
	RB3#0	22.59	22.81	23.04		
	RB3#3	22.56	22.73	23.07		
	RB6#0	21.58	21.74	22.01		
1.4MHz 16QAM	RB1#0	21.67	21.66	21.95	23.16	33
	RB1#3	21.82	21.92	22.06		
	RB1#5	21.64	21.72	21.99		
	RB3#0	21.64	21.84	22.29		
	RB3#3	21.58	21.83	22.25		
	RB6#0	20.58	20.71	21.08		
3MHz QPSK	RB1#0	22.5	22.67	22.97	23.99	33
	RB1#8	22.7	22.86	23.12		
	RB1#14	22.49	22.68	22.94		
	RB6#0	22.59	22.81	23.04		
	RB6#9	22.56	22.73	23.07		
	RB15#0	21.58	21.74	22.01		
3MHz 16QAM	RB1#0	21.67	21.66	21.95	23.16	33
	RB1#8	21.82	21.92	22.06		
	RB1#14	21.64	21.72	21.99		
	RB6#0	21.64	21.84	22.29		
	RB6#9	21.58	21.83	22.25		
	RB15#0	20.58	20.71	21.08		
5MHz QPSK	RB1#0	22.48	22.59	22.91	23.96	33
	RB1#13	22.59	22.71	23.09		
	RB1#24	22.41	22.61	22.93		
	RB15#0	21.51	21.78	22.05		
	RB15#10	21.52	21.8	22.06		
	RB25#0	21.52	21.77	22.02		
5MHz 16QAM	RB1#0	21.8	21.7	21.81	22.84	33
	RB1#13	21.88	21.84	21.97		
	RB1#24	21.71	21.76	21.86		
	RB15#0	20.46	20.77	21.11		
	RB15#10	20.52	20.84	21.12		
	RB25#0	20.5	20.77	21.11		
10MHz QPSK	RB1#0	22.48	22.59	22.91	23.96	33
	RB1#25	22.59	22.71	23.09		
	RB1#49	22.41	22.61	22.93		
	RB25#0	21.51	21.78	22.05		

	RB25#25	21.52	21.8	22.06		
	RB50#0	21.52	21.77	22.02		
10MHz 16QAM	RB1#0	21.8	21.7	21.81	22.84	33
	RB1#25	21.88	21.84	21.97		
	RB1#49	21.71	21.76	21.86		
	RB25#0	20.46	20.77	21.11		
	RB25#25	20.52	20.84	21.12		
	RB50#0	20.5	20.77	21.11		
15MHz QPSK	RB1#0	22.4	22.53	22.68	23.79	33
	RB1#38	22.58	22.75	22.92		
	RB1#74	22.37	22.54	22.79		
	RB36#0	21.55	21.79	22.01		
	RB36#39	21.61	21.82	22.07		
	RB75#0	21.58	21.79	22.04		
15MHz 16QAM	RB1#0	21.55	21.96	22.29	23.43	33
	RB1#38	21.77	22.19	22.56		
	RB1#74	21.5	22.01	22.44		
	RB36#0	20.51	20.7	20.96		
	RB36#39	20.57	20.74	21.07		
	RB75#0	20.61	20.72	21.03		
20MHz QPSK	RB1#0	22.25	22.4	22.54	23.99	33
	RB1#50	22.75	22.89	23.12		
	RB1#99	22.21	22.44	22.68		
	RB50#0	21.59	21.76	22.04		
	RB50#50	21.61	21.8	21.99		
	RB100#0	21.59	21.82	22.04		
20MHz 16QAM	RB1#0	21.87	21.74	21.74	23.17	33
	RB1#50	22.27	22.23	22.3		
	RB1#99	21.85	21.76	21.9		
	RB50#0	20.58	20.78	21.02		
	RB50#50	20.59	20.79	20.98		
	RB100#0	20.58	20.82	21.03		
<p>Note: EIRP=Conducted Power(dBm) - LC(dB) + GT(dBi) GT=0.87dBi, LC=0dB</p>						

LTE Band 5

Test Bandwidth & Modulation	Resource Block & RB offset	Conducted Average Output Power(dBm)			Maximum ERP (dBm)	ERP Limit (dBm)
		Lowest Channel	Middle Channel	Highest Channel		
1.4MHz QPSK	RB1#0	22.92	22.97	22.95	18.51	38.45
	RB1#3	23.14	23.14	23.19		
	RB1#5	22.94	22.99	22.98		
	RB3#0	23.05	23.07	23.06		
	RB3#3	23.08	23.14	23.15		
	RB6#0	21.97	22.03	22.05		
1.4MHz 16QAM	RB1#0	21.94	22.11	21.99	17.62	38.45
	RB1#3	22.1	22.3	22.14		
	RB1#5	21.99	22.13	22.06		
	RB3#0	22.16	21.98	22.19		
	RB3#3	22.16	22.1	22.18		
	RB6#0	21.01	21.08	20.99		
3MHz QPSK	RB1#0	23.06	23.09	23.08	18.45	38.45
	RB1#8	23.13	23.08	23.1		
	RB1#14	23.09	23.07	23.05		
	RB6#0	22.01	21.98	22.04		
	RB6#9	22.04	22.03	22.02		
	RB15#0	22.07	22.06	22.12		
3MHz 16QAM	RB1#0	22.18	22.15	22.64	17.98	38.45
	RB1#8	22.22	22.12	22.65		
	RB1#14	22.24	22.07	22.66		
	RB6#0	21.06	21.02	21.11		
	RB6#9	21.11	21.01	21.15		
	RB15#0	21.01	21.15	21.19		
5MHz QPSK	RB1#0	22.89	22.93	22.94	18.41	38.45
	RB1#13	23.04	23.02	23.09		
	RB1#24	22.94	22.91	22.96		
	RB15#0	22.01	22.06	22.07		
	RB15#10	22	21.97	21.93		
	RB25#0	21.98	21.96	21.96		
5MHz 16QAM	RB1#0	22.18	22.03	21.88	17.64	38.45
	RB1#13	22.32	22.11	21.97		
	RB1#24	22.24	21.98	21.9		
	RB15#0	20.99	21.1	21.1		
	RB15#10	20.97	21.01	21		
	RB25#0	20.99	21	21.04		
10MHz QPSK	RB1#0	22.89	23.01	22.98	18.52	38.45
	RB1#25	23.13	23.2	23.16		
	RB1#49	22.94	23.01	23.04		
	RB25#0	22.06	22.08	22.09		
	RB25#25	22.08	22.01	21.95		

	RB50#0	22.04	22.01	22.04		
10MHz 16QAM	RB1#0	22.48	22.14	21.99	17.96	38.45
	RB1#25	22.64	22.37	22.23		
	RB1#49	22.54	22.16	22.08		
	RB25#0	21.11	21.12	21.17		
	RB25#25	21.1	21.04	21.06		
	RB50#0	21.07	21.08	21.07		
<p>Note: ERP=Conducted Power(dBm) - LC(dB) + GT(dBd) GT=-2.53dBi=-4.68dBd(0dBi=2.15dBd), LC=0dB</p>						

LTE Band 7

Test Bandwidth & Modulation	Resource Block & RB offset	Conducted Average Output Power(dBm)			Maximum EIRP (dBm)	EIRP Limit (dBm)
		Lowest Channel	Middle Channel	Highest Channel		
5MHz QPSK	RB1#0	22.81	22.68	22.63	21.41	33
	RB1#13	22.9	22.78	22.78		
	RB1#24	22.77	22.68	22.68		
	RB15#0	21.85	21.79	21.78		
	RB15#10	21.86	21.75	21.77		
	RB25#0	21.86	21.71	21.73		
5MHz 16QAM	RB1#0	22.08	21.67	21.51	20.71	33
	RB1#13	22.2	21.81	21.64		
	RB1#24	22.06	21.68	21.51		
	RB15#0	20.93	20.83	20.85		
	RB15#10	20.89	20.78	20.8		
	RB25#0	20.92	20.75	20.81		
10MHz QPSK	RB1#0	22.83	22.78	22.66	21.55	33
	RB1#25	23.04	23.01	22.89		
	RB1#49	22.83	22.76	22.73		
	RB25#0	21.97	21.85	21.85		
	RB25#25	21.93	21.8	21.81		
	RB50#0	21.95	21.86	21.8		
10MHz 16QAM	RB1#0	21.97	21.76	22.28	21.02	33
	RB1#25	22.2	22	22.51		
	RB1#49	22	21.68	22.24		
	RB25#0	21.08	20.98	20.91		
	RB25#25	21.02	20.93	20.89		
	RB50#0	21.01	20.91	20.85		
15MHz QPSK	RB1#0	22.72	22.62	22.56	21.41	33
	RB1#38	22.90	22.79	22.76		
	RB1#74	22.66	22.60	22.56		
	RB36#0	21.91	21.85	21.80		
	RB36#39	21.86	21.82	21.84		
	RB75#0	21.89	21.83	21.80		
15MHz 16QAM	RB1#0	21.87	22.02	22.16	20.84	33
	RB1#38	22.03	22.09	22.33		
	RB1#74	21.82	21.86	22.13		
	RB36#0	20.95	20.76	20.78		
	RB36#39	20.90	20.74	20.75		
	RB75#0	20.97	20.76	20.79		
20MHz QPSK	RB1#0	22.54	22.50	22.37	21.57	33
	RB1#50	23.06	22.93	22.86		
	RB1#99	22.57	22.48	22.44		
	RB50#0	21.91	21.78	21.82		
	RB50#50	21.84	21.68	21.73		

	RB100#0	21.85	21.74	21.81		
20MHz 16QAM	RB1#0	21.89	21.71	21.96	20.99	33
	RB1#50	22.37	21.98	22.48		
	RB1#99	21.91	21.62	21.98		
	RB50#0	20.97	20.83	20.88		
	RB50#50	20.87	20.72	20.76		
	RB100#0	20.94	20.81	20.84		
Note: EIRP=Conducted Power(dBm) - LC(dB) + GT(dBi) GT=-1.49dBi, LC=0dB						

LTE Band 12

Test Bandwidth & Modulation	Resource Block & RB offset	Conducted Average Output Power(dBm)			Maximum ERP (dBm)	ERP Limit (dBm)
		Lowest Channel	Middle Channel	Highest Channel		
1.4MHz QPSK	RB1#0	23.51	22.88	22.89	18.46	34.77
	RB1#3	23.15	23.05	23.03		
	RB1#5	22.91	22.85	22.87		
	RB3#0	23.07	22.98	22.98		
	RB3#3	23.09	22.91	22.93		
	RB6#0	22.05	21.98	21.98		
1.4MHz 16QAM	RB1#0	22.00	21.96	21.98	17.18	34.77
	RB1#3	22.01	22.13	22.16		
	RB1#5	22.02	21.96	21.97		
	RB3#0	22.16	22.23	21.94		
	RB3#3	22.13	22.21	21.89		
	RB6#0	20.98	21.02	21.06		
3MHz QPSK	RB1#0	23.06	23.01	23.03	18.01	34.77
	RB1#8	23.04	23.01	23.02		
	RB1#14	23.00	23.00	22.99		
	RB6#0	22.04	22.02	21.93		
	RB6#9	22.10	21.95	21.97		
	RB15#0	22.10	22.06	22.01		
3MHz 16QAM	RB1#0	22.63	22.25	22.16	17.62	34.77
	RB1#8	22.67	22.19	22.11		
	RB1#14	22.63	22.14	22.11		
	RB6#0	21.11	21.07	21.02		
	RB6#9	21.16	21.08	21.08		
	RB15#0	21.15	21.09	21.07		
5MHz QPSK	RB1#0	22.94	22.86	22.83	18	34.77
	RB1#13	23.05	22.96	22.95		
	RB1#24	22.92	22.87	22.81		
	RB15#0	21.95	22.01	21.93		
	RB15#10	22.07	21.94	21.95		
	RB25#0	21.97	21.96	21.94		
5MHz 16QAM	RB1#0	22.23	22.00	21.77	17.33	34.77
	RB1#13	22.38	22.10	21.84		
	RB1#24	22.29	21.96	21.72		
	RB15#0	20.95	21.07	21.03		
	RB15#10	21.06	21.03	21.04		
	RB25#0	20.98	21.02	21.08		
10MHz QPSK	RB1#0	22.91	22.90	22.91	18.09	34.77
	RB1#25	23.12	23.13	23.14		
	RB1#49	22.87	22.92	22.89		
	RB25#0	21.96	22.10	22.02		
	RB25#25	21.99	21.99	22.02		

	RB50#0	22.02	22.07	22.07		
10MHz 16QAM	RB1#0	22.52	22.09	21.97	17.7	34.77
	RB1#25	22.75	22.35	22.16		
	RB1#49	22.47	22.04	21.88		
	RB25#0	21.01	21.13	21.20		
	RB25#25	21.07	21.09	21.21		
	RB50#0	21.00	21.10	21.15		
<p>Note: ERP=Conducted Power(dBm) - LC(dB) + GT(dBd) GT=-2.9dBi=-5.05dBd(0dBi=2.15dBd), LC=0dB</p>						

LTE Band 41

Test Bandwidth & Modulation	Resource Block & RB offset	Conducted Average Output Power(dBm)			Maximum EIRP (dBm)	EIRP Limit (dBm)
		Lowest Channel	Middle Channel	Highest Channel		
5MHz QPSK	RB1#0	23.39	23.18	23.00	22.11	33
	RB1#13	23.70	23.50	23.34		
	RB1#24	23.34	23.11	22.96		
	RB15#0	22.39	22.20	22.06		
	RB15#10	22.37	22.17	21.98		
	RB25#0	22.36	22.19	22.04		
5MHz 16QAM	RB1#0	22.20	22.21	22.13	20.99	33
	RB1#13	22.58	22.56	22.49		
	RB1#24	22.21	22.16	22.14		
	RB15#0	21.40	21.22	21.05		
	RB15#10	21.42	21.18	20.93		
	RB25#0	21.37	21.20	20.99		
10MHz QPSK	RB1#0	23.19	23.00	22.83	21.76	33
	RB1#25	23.35	23.14	22.98		
	RB1#49	23.12	22.89	22.52		
	RB25#0	22.31	22.11	21.58		
	RB25#25	22.31	22.07	21.62		
	RB50#0	22.30	22.11	21.76		
10MHz 16QAM	RB1#0	22.04	22.18	21.73	20.74	33
	RB1#25	22.23	22.33	21.86		
	RB1#49	21.98	22.10	21.65		
	RB25#0	21.19	21.14	20.69		
	RB25#25	21.20	21.09	20.57		
	RB50#0	21.19	21.09	20.64		
15MHz QPSK	RB1#0	22.43	22.10	22.32	21.31	33
	RB1#38	22.90	22.66	22.87		
	RB1#74	22.25	22.05	22.25		
	RB36#0	21.60	21.52	21.69		
	RB36#39	21.49	21.40	21.45		
	RB75#0	21.54	21.48	21.60		
15MHz 16QAM	RB1#0	21.64	21.19	21.28	20.54	33
	RB1#38	22.13	21.73	21.81		
	RB1#74	21.47	21.11	21.21		
	RB36#0	20.69	20.50	20.73		
	RB36#39	20.58	20.40	20.49		
	RB75#0	20.62	20.45	20.60		
20MHz QPSK	RB1#0	22.50	22.67	22.97	21.53	33
	RB1#50	22.70	22.86	23.12		
	RB1#99	22.49	22.68	22.94		
	RB50#0	22.59	22.81	23.04		
	RB50#50	22.56	22.73	23.07		

	RB100#0	21.58	21.74	22.01		
20MHz 16QAM	RB1#0	21.67	21.66	21.95	20.7	33
	RB1#50	21.82	21.92	22.06		
	RB1#99	21.64	21.72	21.99		
	RB50#0	21.64	21.84	22.29		
	RB50#50	21.58	21.83	22.25		
	RB100#0	20.58	20.71	21.08		
Note: EIRP=Conducted Power(dBm) - LC(dB) + GT(dBi) GT=-1.59dBi, LC=0dB						

3.3.2 Peak-to-average ratio (PAR)

Cellular Band

Test Mode	Peak-to-average Ratio(dB)			Limit (dB)
	Lowest Channel	Middle Channel	Highest Channel	
WCDMA R99	7.77	6.84	7.93	13
HSDPA	9.61	7.25	9.58	13
HSUPA	6.04	6.32	7.47	13

PCS Band

Test Mode	Peak-to-average Ratio(dB)			Limit (dB)
	Lowest Channel	Middle Channel	Highest Channel	
WCDMA R99	7.98	6.23	6.69	13
HSDPA	7.68	8.18	8.76	13
HSUPA	6.75	7.21	6.23	13

LTE Band 2 20MHz Bandwidth

Test Bandwidth & Modulation	Resource Block & RB offset	Peak-to-average Ratio(dB)			Limit (dB)
		Lowest Channel	Middle Channel	Highest Channel	
20MHz QPSK	RB1#0	8.91	6.48	7.83	13
	RB100#0	8.67	9.97	7.86	13
20MHz 16QAM	RB1#0	9.05	6.96	9.34	13
	RB100#0	9.86	7.96	8.98	13

LTE Band 5 10MHz Bandwidth

Test Bandwidth & Modulation	Resource Block & RB offset	Peak-to-average Ratio(dB)			Limit (dB)
		Lowest Channel	Middle Channel	Highest Channel	
10MHz QPSK	RB1#0	6.39	6.31	9.31	13
	RB50#0	6.21	8.36	7.45	13
10MHz 16QAM	RB1#0	9.94	6.89	8.86	13
	RB50#0	6.92	8.55	9.69	13

LTE Band 7 20MHz Bandwidth

Test Bandwidth & Modulation	Resource Block & RB offset	Peak-to-average Ratio(dB)			Limit (dB)
		Lowest Channel	Middle Channel	Highest Channel	
20MHz QPSK	RB1#0	6.67	7.6	8.89	13
	RB100#0	7.9	6.99	7.71	13
20MHz 16QAM	RB1#0	7.75	8.79	9.37	13
	RB100#0	9.24	8.43	7.4	13

LTE Band 12 10MHz Bandwidth

Test Bandwidth & Modulation	Resource Block & RB offset	Peak-to-average Ratio(dB)			Limit (dB)
		Lowest Channel	Middle Channel	Highest Channel	
10MHz QPSK	RB1#0	9.09	8.73	8.12	13
	RB50#0	7.86	6.75	9.3	13
10MHz 16QAM	RB1#0	9.39	6.64	9.26	13
	RB50#0	6.66	6.31	7.27	13

LTE Band 41 20MHz Bandwidth

Test Bandwidth & Modulation	Resource Block & RB offset	Peak-to-average Ratio(dB)			Limit (dB)
		Lowest Channel	Middle Channel	Highest Channel	
20MHz QPSK	RB1#0	6	9.58	9.04	13
	RB100#0	8.83	9.44	7.61	13
20MHz 16QAM	RB1#0	8.85	6.92	8.96	13
	RB100#0	9.83	8.62	6.44	13

3.3.3 26dB and 99% Bandwidth

Cellular Band

Operation Mode	99% Occupied Bandwidth (MHz)			26 dB Occupied Bandwidth (MHz)		
	Low Channel	Middle channel	High Channel	Low Channel	Middle Channel	High Channel
GSM	0.243	0.245	0.244	0.317	0.317	0.315

Operation Mode	99% Occupied Bandwidth (MHz)			26 dB Occupied Bandwidth (MHz)		
	Low Channel	Middle channel	High Channel	Low Channel	Middle Channel	High Channel
WCDMA R99	4.166	4.166	4.156	4.715	4.725	4.715
HSDPA	4.196	4.206	4.196	5.115	5.914	4.875
HSUPA	4.226	4.206	4.196	5.455	5.544	5.155

PCS Band

Operation Mode	99% Occupied Bandwidth (MHz)			26 dB Occupied Bandwidth (MHz)		
	Low Channel	Middle channel	High Channel	Low Channel	Middle Channel	High Channel
GSM	0.243	0.244	0.243	0.316	0.313	0.315

Operation Mode	99% Occupied Bandwidth (MHz)			26 dB Occupied Bandwidth (MHz)		
	Low Channel	Middle channel	High Channel	Low Channel	Middle Channel	High Channel
WCDMA R99	4.156	4.176	4.166	4.715	4.735	4.745
HSDPA	4.196	4.186	4.236	4.865	4.725	7.023
HSUPA	4.216	4.186	4.246	5.395	4.955	6.184

LTE Band 2

Operation Mode	99% Occupied Bandwidth (MHz)			26 dB Occupied Bandwidth (MHz)		
	Low Channel	Middle channel	High Channel	Low Channel	Middle Channel	High Channel
1.4MHz QPSK	1.102	1.096	1.102	1.284	1.296	1.314
1.4MHz 16QAM	1.089	1.096	1.096	1.290	1.320	1.296
3MHz QPSK	2.683	2.683	2.683	2.892	2.880	2.880
3MHz 16QAM	2.683	2.683	2.683	2.868	2.892	2.880
5MHz QPSK	4.491	4.511	4.511	4.940	4.960	4.920
5MHz 16QAM	4.511	4.511	4.511	4.960	5.060	4.940
10MHz QPSK	8.942	8.942	8.942	9.560	9.600	9.680
10MHz 16QAM	8.942	8.982	8.942	9.680	9.680	9.600
15MHz QPSK	13.473	13.533	13.473	14.700	14.760	14.580
15MHz 16QAM	13.533	13.533	13.533	14.580	14.640	14.640
20MHz QPSK	17.884	17.964	17.884	19.280	19.520	19.120
20MHz 16QAM	18.044	18.044	17.964	19.360	19.440	19.200

LTE Band 5

Operation Mode	99% Occupied Bandwidth (MHz)			26 dB Occupied Bandwidth (MHz)		
	Low Channel	Middle channel	High Channel	Low Channel	Middle Channel	High Channel
1.4MHz QPSK	1.102	1.096	1.102	1.308	1.290	1.314
1.4MHz 16QAM	1.102	1.096	1.090	1.308	1.314	1.278
3MHz QPSK	2.683	2.683	2.683	2.892	2.868	2.868
3MHz 16QAM	2.683	2.683	2.683	2.868	2.892	2.868
5MHz QPSK	4.491	4.491	4.471	4.960	4.960	4.920
5MHz 16QAM	4.471	4.511	4.491	4.920	4.960	4.980
10MHz QPSK	8.942	8.942	8.942	9.640	9.680	9.640
10MHz 16QAM	8.982	8.942	8.942	9.600	9.600	9.640

LTE Band 7

Operation Mode	99% Occupied Bandwidth (MHz)			26 dB Occupied Bandwidth (MHz)		
	Low Channel	Middle channel	High Channel	Low Channel	Middle Channel	High Channel
5MHz QPSK	4.511	4.491	4.511	4.980	4.940	4.960
5MHz 16QAM	4.511	4.511	4.491	4.980	5.000	4.940
10MHz QPSK	8.942	8.982	8.982	9.560	9.680	9.640
10MHz 16QAM	8.942	8.982	8.942	9.640	9.600	9.520
15MHz QPSK	13.473	13.533	13.413	14.700	14.760	14.640
15MHz 16QAM	13.473	13.533	13.473	14.700	14.700	14.700
20MHz QPSK	17.964	17.964	17.964	19.360	19.200	19.120
20MHz 16QAM	18.044	17.964	17.964	19.360	19.280	19.520

LTE Band 12

Operation Mode	99% Occupied Bandwidth (MHz)			26 dB Occupied Bandwidth (MHz)		
	Low Channel	Middle channel	High Channel	Low Channel	Middle Channel	High Channel
1.4MHz QPSK	1.102	1.096	1.102	1.290	1.296	1.326
1.4MHz 16QAM	1.096	1.096	1.090	1.290	1.320	1.278
3MHz QPSK	2.683	2.683	2.683	2.880	2.856	2.868
3MHz 16QAM	2.683	2.683	2.683	2.880	2.880	2.880
5MHz QPSK	4.491	4.551	4.511	5.140	5.220	5.180
5MHz 16QAM	4.531	4.511	4.551	5.220	5.140	5.220
10MHz QPSK	8.942	8.982	8.942	9.920	9.960	9.880
10MHz 16QAM	8.942	8.942	8.942	9.840	9.760	9.960

LTE Band 41

Operation Mode	99% Occupied Bandwidth (MHz)			26 dB Occupied Bandwidth (MHz)		
	Low Channel	Middle channel	High Channel	Low Channel	Middle Channel	High Channel
5MHz QPSK	4.511	4.511	4.511	5.040	5.020	5.000
5MHz 16QAM	4.511	4.491	4.511	5.300	4.940	4.940
10MHz QPSK	8.942	8.942	8.942	9.680	9.680	9.920
10MHz 16QAM	8.942	8.942	8.942	9.520	9.640	9.640
15MHz QPSK	13.533	13.473	13.473	14.640	15.360	14.700
15MHz 16QAM	13.533	13.533	13.533	14.700	15.240	14.580
20MHz QPSK	17.964	17.964	17.964	19.840	19.120	19.360
20MHz 16QAM	17.964	17.884	17.884	19.360	19.280	19.200

Note: Test Plots of 26dB and 99% bandwidth please refer Appendix A

3.3.4 Conducted Spurious Emissions

Band	Result	Limit	Verdict
GSM850	Refer test plot	Refer test plot	Pass
PCS1900	Refer test plot	Refer test plot	Pass
WCDMA B2	Refer test plot	Refer test plot	Pass
WCDMA B4	Refer test plot	Refer test plot	Pass
LTE B2	Refer test plot	Refer test plot	Pass
LTE B5	Refer test plot	Refer test plot	Pass
LTE B7	Refer test plot	Refer test plot	Pass
LTE B12	Refer test plot	Refer test plot	Pass
LTE B41	Refer test plot	Refer test plot	Pass

Note: Test Plots of Conducted Spurious Emissions please refer Appendix B

3.3.5 Out of band emission, Band Edge

Band	Result	Limit	Verdict
GSM850	Refer test plot	Refer test plot	Pass
PCS1900	Refer test plot	Refer test plot	Pass
WCDMA B2	Refer test plot	Refer test plot	Pass
WCDMA B4	Refer test plot	Refer test plot	Pass
LTE B2	Refer test plot	Refer test plot	Pass
LTE B5	Refer test plot	Refer test plot	Pass
LTE B7	Refer test plot	Refer test plot	Pass
LTE B12	Refer test plot	Refer test plot	Pass
LTE B41	Refer test plot	Refer test plot	Pass

Note: Test Plots of Band Edge please refer Appendix C

3.3.6 FREQUENCY STABILITY

Cellular Band

GSM Mode

Test Modulation:	GMSK		Test Channel:	836.6	MHz
Test Item	Temperature (°C)	Voltage (V _{DC})	Frequency Error		Limit
			(Hz)	(ppm)	(ppm)
Frequency Stability vs. Temperature	-30	3.45	100.296	0.120	2.5
	-20	3.45	112.193	0.134	2.5
	-10	3.45	104.788	0.125	2.5
	0	3.45	105.461	0.126	2.5
	10	3.45	116.996	0.140	2.5
	20	3.45	108.516	0.130	2.5
	30	3.45	103.617	0.124	2.5
	40	3.45	114.050	0.136	2.5
	50	3.45	107.315	0.128	2.5
Frequency Stability vs. Voltage	20	3.87	100.334	0.120	2.5
	20	4.4	102.303	0.122	2.5

WCDMA Mode

Test Modulation:	WCDMA R99		Test Channel:	836.6	MHz
Test Item	Temperature (°C)	Voltage (V _{DC})	Frequency Error		Limit
			(Hz)	(ppm)	(ppm)
Frequency Stability vs. Temperature	-30	3.45	102.591	0.123	2.5
	-20	3.45	104.401	0.125	2.5
	-10	3.45	119.711	0.143	2.5
	0	3.45	105.301	0.126	2.5
	10	3.45	109.866	0.131	2.5
	20	3.45	102.665	0.123	2.5
	30	3.45	106.317	0.127	2.5
	40	3.45	109.966	0.131	2.5
	50	3.45	114.632	0.137	2.5
Frequency Stability vs. Voltage	20	3.87	118.141	0.141	2.5
	20	4.4	115.986	0.139	2.5

**PCS Band
GSM Mode**

Test Mode:	GMSK	Test Channel: Lowest for Lower Edge, Highest for Upper Edge				
Test Item	Temperature (°C)	Voltage (V _{DC})	Lower Edge (MHz)		Upper Edge (MHz)	
			Result	Limit	Result	Limit
Frequency Stability vs. Temperature	-30	3.45	1850.020	1850.000	1909.998	1910.000
	-20	3.45	1850.012	1850.000	1909.995	1910.000
	-10	3.45	1850.022	1850.000	1909.982	1910.000
	0	3.45	1850.030	1850.000	1909.996	1910.000
	10	3.45	1850.005	1850.000	1909.985	1910.000
	20	3.45	1850.015	1850.000	1909.991	1910.000
	30	3.45	1850.019	1850.000	1909.975	1910.000
	40	3.45	1850.006	1850.000	1909.970	1910.000
Frequency Stability vs. Voltage	20	3.87	1850.011	1850.000	1909.975	1910.000
	20	4.4	1850.013	1850.000	1909.976	1910.000

WCDMA Mode

Test Mode:	WCDMA R99	Test Channel: Lowest for Lower Edge, Highest for Upper Edge				
Test Item	Temperature (°C)	Voltage (V _{DC})	Lower Edge (MHz)		Upper Edge (MHz)	
			Result	Limit	Result	Limit
Frequency Stability vs. Temperature	-30	3.45	1850.015	1850.000	1909.999	1910.000
	-20	3.45	1850.028	1850.000	1909.973	1910.000
	-10	3.45	1850.024	1850.000	1909.997	1910.000
	0	3.45	1850.027	1850.000	1909.220	1910.000
	10	3.45	1850.018	1850.000	1909.985	1910.000
	20	3.45	1850.023	1850.000	1909.980	1910.000
	30	3.45	1850.012	1850.000	1909.991	1910.000
	40	3.45	1850.014	1850.000	1909.980	1910.000
Frequency Stability vs. Voltage	20	3.87	1850.024	1850.000	1909.983	1910.000
	20	4.4	1850.006	1850.000	1909.996	1910.000

LTE:
QPSK:
Band 2

Test Mode:	20M QPSK	Test Channel: Lowest for Lower Edge, Highest for Upper Edge				
Test Item	Temperature (°C)	Voltage (V _{DC})	Lower Edge (MHz)		Upper Edge (MHz)	
			Result	Limit	Result	Limit
Frequency Stability vs. Temperature	-30	3.45	1850.028	1850.000	1909.732	1910.000
	-20	3.45	1850.007	1850.000	1909.654	1910.000
	-10	3.45	1850.023	1850.000	1909.453	1910.000
	0	3.45	1850.231	1850.000	1909.781	1910.000
	10	3.45	1850.025	1850.000	1909.541	1910.000
	20	3.45	1850.008	1850.000	1909.538	1910.000
	30	3.45	1850.007	1850.000	1909.768	1910.000
	40	3.45	1850.020	1850.000	1909.547	1910.000
Frequency Stability vs. Voltage	50	3.45	1850.006	1850.000	1909.638	1910.000
	20	3.87	1850.001	1850.000	1909.785	1910.000
	20	4.4	1850.026	1850.000	1909.463	1910.000

Band 5

Test Modulation:	10 MHz QPSK		Test Channel:	836.5	MHz
Test Item	Temperature (°C)	Voltage (V _{DC})	Frequency Error		Limit
			(Hz)	(ppm)	(ppm)
Frequency Stability vs. Temperature	-30	3.45	110.721	0.132	2.5
	-20	3.45	117.867	0.141	2.5
	-10	3.45	107.585	0.129	2.5
	0	3.45	112.266	0.134	2.5
	10	3.45	116.845	0.140	2.5
	20	3.45	112.958	0.135	2.5
	30	3.45	109.629	0.131	2.5
	40	3.45	116.394	0.139	2.5
Frequency Stability vs. Voltage	50	3.45	113.198	0.135	2.5
	20	3.87	118.514	0.142	2.5
	20	4.4	113.066	0.135	2.5

Band 7

Test Mode:	20M QPSK	Test Channel: Lowest for Lower Edge, Highest for Upper Edge				
Test Item	Temperature (°C)	Voltage (V _{DC})	Lower Edge (MHz)		Upper Edge (MHz)	
			Result	Limit	Result	Limit
Frequency Stability vs. Temperature	-30	3.45	2500.027	2500.00	2569.987	2570
	-20	3.45	2500.032	2500.00	2569.987	2570
	-10	3.45	2500.021	2500.00	2569.979	2570
	0	3.45	2500.029	2500.00	2569.981	2570
	10	3.45	2500.026	2500.00	2569.978	2570
	20	3.45	2500.021	2500.00	2569.962	2570
	30	3.45	2500.020	2500.00	2569.962	2570
	40	3.45	2500.034	2500.00	2569.968	2570
Frequency Stability vs. Voltage	50	3.45	2500.031	2500.00	2569.988	2570
	20	3.87	2500.010	2500.00	2569.982	2570
	20	4.4	2500.033	2500.00	2569.987	2570

Band 12

Test Mode:	10M QPSK	Test Channel: Lowest for Lower Edge, Highest for Upper Edge				
Test Item	Temperature (°C)	Voltage (V _{DC})	Lower Edge (MHz)		Upper Edge (MHz)	
			Result	Limit	Result	Limit
Frequency Stability vs. Temperature	-30	3.45	699.011	699.00	715.983	716.00
	-20	3.45	699.018	699.00	715.967	716.00
	-10	3.45	699.036	699.00	715.982	716.00
	0	3.45	699.022	699.00	715.984	716.00
	10	3.45	699.026	699.00	715.973	716.00
	20	3.45	699.040	699.00	715.984	716.00
	30	3.45	699.023	699.00	715.982	716.00
	40	3.45	699.025	699.00	715.975	716.00
Frequency Stability vs. Voltage	50	3.45	699.018	699.00	715.980	716.00
	20	3.87	699.020	699.00	715.980	716.00
	20	4.4	699.040	699.00	715.986	716.00

Band 41

Test Mode:	20M QPSK	Test Channel: Lowest for Lower Edge, Highest for Upper Edge				
Test Item	Temperature (°C)	Voltage (V _{DC})	Lower Edge (MHz)		Upper Edge (MHz)	
			Result	Limit	Result	Limit
Frequency Stability vs. Temperature	-30	3.45	2535.009	2535.00	2654.977	2655
	-20	3.45	2535.021	2535.00	2654.365	2655
	-10	3.45	2535.026	2535.00	2654.981	2655
	0	3.45	2535.009	2535.00	2654.971	2655
	10	3.45	2535.009	2535.00	2654.972	2655
	20	3.45	2535.010	2535.00	2654.973	2655
	30	3.45	2535.231	2535.00	2654.993	2655
	40	3.45	2535.324	2535.00	2654.987	2655
Frequency Stability vs. Voltage	50	3.45	2535.028	2535.00	2654.981	2655
	20	3.87	2535.009	2535.00	2654.984	2655
	20	4.4	2535.024	2535.00	2654.996	2655

16QAM:

Band 2

Test Mode:	20M 16QAM	Test Channel: Lowest for Lower Edge, Highest for Upper Edge				
Test Item	Temperature (°C)	Voltage (V _{DC})	Lower Edge (MHz)		Upper Edge (MHz)	
			Result	Limit	Result	Limit
Frequency Stability vs. Temperature	-30	3.45	1850.022	1850.000	1909.988	1910.000
	-20	3.45	1850.012	1850.000	1909.986	1910.000
	-10	3.45	1850.021	1850.000	1909.983	1910.000
	0	3.45	1850.004	1850.000	1909.985	1910.000
	10	3.45	1850.021	1850.000	1909.976	1910.000
	20	3.45	1850.007	1850.000	1909.971	1910.000
	30	3.45	1850.009	1850.000	1909.973	1910.000
	40	3.45	1850.016	1850.000	1909.961	1910.000
Frequency Stability vs. Voltage	20	3.87	1850.002	1850.000	1909.987	1910.000
	20	4.4	1850.012	1850.000	1909.981	1910.000

Band 5

Test Modulation:	10 MHz 16QAM		Test Channel:	836.5	MHz
Test Item	Temperature (°C)	Voltage (V _{DC})	Frequency Error		Limit
			(Hz)	(ppm)	(ppm)
Frequency Stability vs. Temperature	-30	3.45	100.795	0.120	2.5
	-20	3.45	105.411	0.126	2.5
	-10	3.45	108.771	0.130	2.5
	0	3.45	110.977	0.133	2.5
	10	3.45	108.106	0.129	2.5
	20	3.45	115.942	0.139	2.5
	30	3.45	107.475	0.128	2.5
	40	3.45	104.949	0.125	2.5
Frequency Stability vs. Voltage	20	3.87	103.039	0.123	2.5
	20	4.4	114.968	0.137	2.5

Band 7

Test Mode:	20M 16QAM	Test Channel: Lowest for Lower Edge, Highest for Upper Edge				
Test Item	Temperature (°C)	Voltage (V _{DC})	Lower Edge (MHz)		Upper Edge (MHz)	
			Result	Limit	Result	Limit
Frequency Stability vs. Temperature	-30	3.45	2500.028	2500.00	2569.962	2570
	-20	3.45	2500.004	2500.00	2569.972	2570
	-10	3.45	2500.029	2500.00	2569.978	2570
	0	3.45	2500.026	2500.00	2569.979	2570
	10	3.45	2500.020	2500.00	2569.968	2570
	20	3.45	2500.026	2500.00	2569.989	2570
	30	3.45	2500.028	2500.00	2569.963	2570
	40	3.45	2500.023	2500.00	2569.969	2570
Frequency Stability vs. Voltage	50	3.45	2500.026	2500.00	2569.964	2570
	20	3.87	2500.018	2500.00	2569.964	2570
	20	4.4	2500.006	2500.00	2569.974	2570

Band 12

Test Mode:	10M 16QAM	Test Channel: Lowest for Lower Edge, Highest for Upper Edge				
Test Item	Temperature (°C)	Voltage (V _{DC})	Lower Edge (MHz)		Upper Edge (MHz)	
			Result	Limit	Result	Limit
Frequency Stability vs. Temperature	-30	3.45	699.016	699.00	715.970	716.00
	-20	3.45	699.019	699.00	715.978	716.00
	-10	3.45	699.027	699.00	715.989	716.00
	0	3.45	699.021	699.00	715.985	716.00
	10	3.45	699.031	699.00	715.971	716.00
	20	3.45	699.025	699.00	715.961	716.00
	30	3.45	699.027	699.00	715.988	716.00
	40	3.45	699.037	699.00	715.987	716.00
Frequency Stability vs. Voltage	50	3.45	699.035	699.00	715.989	716.00
	20	3.87	699.020	699.00	715.969	716.00
	20	4.4	699.024	699.00	715.989	716.00

Band 41

Test Mode:	20M 16QAM	Test Channel: Lowest for Lower Edge, Highest for Upper Edge				
Test Item	Temperature (°C)	Voltage (V _{DC})	Lower Edge (MHz)		Upper Edge (MHz)	
			Result	Limit	Result	Limit
Frequency Stability vs. Temperature	-30	3.45	2535.024	2535.00	2654.979	2655
	-20	3.45	2535.006	2535.00	2654.973	2655
	-10	3.45	2535.017	2535.00	2654.984	2655
	0	3.45	2535.012	2535.00	2654.985	2655
	10	3.45	2535.013	2535.00	2654.979	2655
	20	3.45	2535.014	2535.00	2654.995	2655
	30	3.45	2535.154	2535.00	2654.993	2655
	40	3.45	2535.164	2535.00	2654.980	2655
Frequency Stability vs. Voltage	50	3.45	2535.073	2535.00	2654.979	2655
	20	3.87	2535.064	2535.00	2654.996	2655
	20	4.4	2535.052	2535.00	2654.987	2655

3.4 Radiated Spurious emission Test Data

Test Date:	2024-02-04	Test By:	Luke Li
Environment condition:	Temperature: 24°C; Relative Humidity: 68%; ATM Pressure: 100.2kPa		

Frequency (MHz)	Reading level (dBμV)	Polar (H/V)	Corrected Factor (dB/m)	Corrected Amplitude (dBμV/m)	EIRP CF	Corrected Reading (dBm)	Limit (dBm)	Margin (dB)	Remark
GSM 850									
Low Channel									
1648.4	56.95	Horizontal	-2.55	54.4	-95.2	-40.8	-13	-27.8	Peak
1648.4	57.05	Vertical	-2.55	54.5	-95.2	-40.7	-13	-27.7	Peak
2472.6	57.96	Horizontal	-1.76	56.2	-95.2	-39	-13	-26	Peak
2472.6	59.06	Vertical	-1.76	57.3	-95.2	-37.9	-13	-24.9	Peak
3296.8	49.95	Horizontal	-1.85	48.1	-95.2	-47.1	-13	-34.1	Peak
3296.8	50.75	Vertical	-1.85	48.9	-95.2	-46.3	-13	-33.3	Peak
Middle Channel									
1673.2	58.16	Horizontal	-2.46	55.7	-95.2	-39.5	-13	-26.5	Peak
1673.2	58.06	Vertical	-2.46	55.6	-95.2	-39.6	-13	-26.6	Peak
2509.8	59.04	Horizontal	-1.74	57.3	-95.2	-37.9	-13	-24.9	Peak
2509.8	59.74	Vertical	-1.74	58	-95.2	-37.2	-13	-24.2	Peak
3346.4	50.1	Horizontal	-1.8	48.3	-95.2	-46.9	-13	-33.9	Peak
3346.4	51.6	Vertical	-1.8	49.8	-95.2	-45.4	-13	-32.4	Peak
High Channel									
1697.6	58.67	Horizontal	-2.37	56.3	-95.2	-38.9	-13	-25.9	Peak
1697.6	58.67	Vertical	-2.37	56.3	-95.2	-38.9	-13	-25.9	Peak
2546.4	58.97	Horizontal	-1.77	57.2	-95.2	-38	-13	-25	Peak
2546.4	60.27	Vertical	-1.77	58.5	-95.2	-36.7	-13	-23.7	Peak
3395.2	51.15	Horizontal	-1.75	49.4	-95.2	-45.8	-13	-32.8	Peak
3395.2	52.05	Vertical	-1.75	50.3	-95.2	-44.9	-13	-31.9	Peak

Frequency (MHz)	Reading level (dB μ V)	Polar (H/V)	Corrected Factor (dB/m)	Corrected Amplitude (dB μ V/m)	EIRP CF	Corrected Reading (dBm)	Limit (dBm)	Margin (dB)	Remark
PCS 1900									
Low Channel									
3700.4	50.58	Horizontal	-1.58	49	-95.2	-46.2	-13	-33.2	Peak
3700.4	50.08	Vertical	-1.58	48.5	-95.2	-46.7	-13	-33.7	Peak
5550.6	54.58	Horizontal	1.72	56.3	-95.2	-38.9	-13	-25.9	Peak
5550.6	55.28	Vertical	1.72	57	-95.2	-38.2	-13	-25.2	Peak
Middle Channel									
3760	51.95	Horizontal	-1.75	50.2	-95.2	-45	-13	-32	Peak
3760	51.25	Vertical	-1.75	49.5	-95.2	-45.7	-13	-32.7	Peak
5640	55.09	Horizontal	1.91	57	-95.2	-38.2	-13	-25.2	Peak
5640	55.99	Vertical	1.91	57.9	-95.2	-37.3	-13	-24.3	Peak
High Channel									
3819.6	52.99	Horizontal	-1.89	51.1	-95.2	-44.1	-13	-31.1	Peak
3819.6	52.49	Vertical	-1.89	50.6	-95.2	-44.6	-13	-31.6	Peak
5729.4	56.66	Horizontal	2.04	58.7	-95.2	-36.5	-13	-23.5	Peak
5729.4	57.26	Vertical	2.04	59.3	-95.2	-35.9	-13	-22.9	Peak

Frequency (MHz)	Reading level (dBμV)	Polar (H/V)	Corrected Factor (dB/m)	Corrected Amplitude (dBμV/m)	EIRP CF	Corrected Reading (dBm)	Limit (dBm)	Margin (dB)	Remark
WCDMA 1900									
Low Channel									
3704.8	46.29	Horizontal	-1.59	44.7	-95.2	-50.5	-13	-37.5	Peak
3704.8	46.29	Vertical	-1.59	44.7	-95.2	-50.5	-13	-37.5	Peak
5557.2	47.55	Horizontal	1.75	49.3	-95.2	-45.9	-13	-32.9	Peak
5557.2	47.55	Vertical	1.75	49.3	-95.2	-45.9	-13	-32.9	Peak
Middle Channel									
3760	47.35	Horizontal	-1.75	45.6	-95.2	-49.6	-13	-36.6	Peak
3760	47.35	Vertical	-1.75	45.6	-95.2	-49.6	-13	-36.6	Peak
5640	47.69	Horizontal	1.91	49.6	-95.2	-45.6	-13	-32.6	Peak
5640	47.59	Vertical	1.91	49.5	-95.2	-45.7	-13	-32.7	Peak
High Channel									
3815.2	48.09	Horizontal	-1.89	46.2	-95.2	-49	-13	-36	Peak
3815.2	48.59	Vertical	-1.89	46.7	-95.2	-48.5	-13	-35.5	Peak
5722.8	48.97	Horizontal	2.03	51	-95.2	-44.2	-13	-31.2	Peak
5722.8	49.17	Vertical	2.03	51.2	-95.2	-44	-13	-31	Peak

Frequency (MHz)	Reading level (dB μ V)	Polar (H/V)	Corrected Factor (dB/m)	Corrected Amplitude (dB μ V/m)	EIRP CF	Corrected Reading (dBm)	Limit (dBm)	Margin (dB)	Remark
WCDMA 850									
Low Channel									
1652.8	50.22	Horizontal	-2.52	47.7	-95.2	-47.5	-13	-34.5	Peak
1652.8	48.02	Vertical	-2.52	45.5	-95.2	-49.7	-13	-36.7	Peak
2479.2	45.95	Horizontal	-1.75	44.2	-95.2	-51	-13	-38	Peak
2479.2	45.65	Vertical	-1.75	43.9	-95.2	-51.3	-13	-38.3	Peak
3305.6	45.34	Horizontal	-1.84	43.5	-95.2	-51.7	-13	-38.7	Peak
3305.6	45.14	Vertical	-1.84	43.3	-95.2	-51.9	-13	-38.9	Peak
Middle Channel									
1673.2	51.06	Horizontal	-2.46	48.6	-95.2	-46.6	-13	-33.6	Peak
1673.2	50.06	Vertical	-2.46	47.6	-95.2	-47.6	-13	-34.6	Peak
2509.8	46.35	Horizontal	-1.75	44.6	-95.2	-50.6	-13	-37.6	Peak
2509.8	46.15	Vertical	-1.75	44.4	-95.2	-50.8	-13	-37.8	Peak
3346.4	45.6	Horizontal	-1.8	43.8	-95.2	-51.4	-13	-38.4	Peak
3346.4	45.5	Vertical	-1.8	43.7	-95.2	-51.5	-13	-38.5	Peak
High Channel									
1693.2	51.89	Horizontal	-2.39	49.5	-95.2	-45.7	-13	-32.7	Peak
1693.2	49.69	Vertical	-2.39	47.3	-95.2	-47.9	-13	-34.9	Peak
2539.8	46.86	Horizontal	-1.76	45.1	-95.2	-50.1	-13	-37.1	Peak
2539.8	47.66	Vertical	-1.76	45.9	-95.2	-49.3	-13	-36.3	Peak
3386.4	46.65	Horizontal	-1.75	44.9	-95.2	-50.3	-13	-37.3	Peak
3386.4	46.35	Vertical	-1.75	44.6	-95.2	-50.6	-13	-37.6	Peak

Frequency (MHz)	Reading level (dBμV)	Polar (H/V)	Corrected Factor (dB/m)	Corrected Amplitude (dBμV/m)	EIRP CF	Corrected Reading (dBm)	Limit (dBm)	Margin (dB)	Remark
LTE Band 2									
Low Channel									
3701.4	47.58	Horizontal	-1.58	46	-95.2	-49.2	-13	-36.2	Peak
3701.4	48.08	Vertical	-1.58	46.5	-95.2	-48.7	-13	-35.7	Peak
5552.1	55.58	Horizontal	1.72	57.3	-95.2	-37.9	-13	-24.9	Peak
5552.1	54.38	Vertical	1.72	56.1	-95.2	-39.1	-13	-26.1	Peak
Middle Channel									
3760	48.85	Horizontal	-1.75	47.1	-95.2	-48.1	-13	-35.1	Peak
3760	48.25	Vertical	-1.75	46.5	-95.2	-48.7	-13	-35.7	Peak
5640	56.09	Horizontal	1.91	58	-95.2	-37.2	-13	-24.2	Peak
5640	54.59	Vertical	1.91	56.5	-95.2	-38.7	-13	-25.7	Peak
High Channel									
3818.6	50.1	Horizontal	-1.9	48.2	-95.2	-47	-13	-34	Peak
3818.6	49.5	Vertical	-1.9	47.6	-95.2	-47.6	-13	-34.6	Peak
5727.9	57.36	Horizontal	2.04	59.4	-95.2	-35.8	-13	-22.8	Peak
5727.9	55.96	Vertical	2.04	58	-95.2	-37.2	-13	-24.2	Peak

Frequency (MHz)	Reading level (dB μ V)	Polar (H/V)	Corrected Factor (dB/m)	Corrected Amplitude (dB μ V/m)	EIRP CF	Corrected Reading (dBm)	Limit (dBm)	Margin (dB)	Remark
LTE B5									
Low Channel									
1649.4	48.84	Horizontal	-2.54	46.3	-95.2	-48.9	-13	-35.9	Peak
1649.4	47.94	Vertical	-2.54	45.4	-95.2	-49.8	-13	-36.8	Peak
2474.1	46.47	Horizontal	-1.77	44.7	-95.2	-50.5	-13	-37.5	Peak
2474.1	45.97	Vertical	-1.77	44.2	-95.2	-51	-13	-38	Peak
3298.8	45.95	Horizontal	-1.85	44.1	-95.2	-51.1	-13	-38.1	Peak
3298.8	45.75	Vertical	-1.85	43.9	-95.2	-51.3	-13	-38.3	Peak
Middle Channel									
1673	49.56	Horizontal	-2.46	47.1	-95.2	-48.1	-13	-35.1	Peak
1673	48.46	Vertical	-2.46	46	-95.2	-49.2	-13	-36.2	Peak
2509.5	46.25	Horizontal	-1.75	44.5	-95.2	-50.7	-13	-37.7	Peak
2509.5	46.15	Vertical	-1.75	44.4	-95.2	-50.8	-13	-37.8	Peak
3346	46.4	Horizontal	-1.8	44.6	-95.2	-50.6	-13	-37.6	Peak
3346	46.2	Vertical	-1.8	44.4	-95.2	-50.8	-13	-37.8	Peak
High Channel									
1696.6	50.79	Horizontal	-2.39	48.4	-95.2	-46.8	-13	-33.8	Peak
1696.6	49.49	Vertical	-2.39	47.1	-95.2	-48.1	-13	-35.1	Peak
2544.9	47.56	Horizontal	-1.76	45.8	-95.2	-49.4	-13	-36.4	Peak
2544.9	47.06	Vertical	-1.76	45.3	-95.2	-49.9	-13	-36.9	Peak
3393.2	47.35	Horizontal	-1.75	45.6	-95.2	-49.6	-13	-36.6	Peak
3393.2	46.95	Vertical	-1.75	45.2	-95.2	-50	-13	-37	Peak

Frequency (MHz)	Reading level (dB μ V)	Polar (H/V)	Corrected Factor (dB/m)	Corrected Amplitude (dB μ V/m)	EIRP CF	Corrected Reading (dBm)	Limit (dBm)	Margin (dB)	Remark
LTE Band 7									
Low Channel									
5005	46.78	Horizontal	1.22	48	-95.2	-47.2	-25	-22.2	Peak
5005	46.98	Vertical	1.22	48.2	-95.2	-47	-25	-22	Peak
7507.5	51.67	Horizontal	3.23	54.9	-95.2	-40.3	-25	-15.3	Peak
7507.5	51.77	Vertical	3.23	55	-95.2	-40.2	-25	-15.2	Peak
Middle Channel									
5070	47.33	Horizontal	1.37	48.7	-95.2	-46.5	-25	-21.5	Peak
5070	47.43	Vertical	1.37	48.8	-95.2	-46.4	-25	-21.4	Peak
7605	52.49	Horizontal	3.31	55.8	-95.2	-39.4	-25	-14.4	Peak
7605	52.49	Vertical	3.31	55.8	-95.2	-39.4	-25	-14.4	Peak
High Channel									
5135	48.07	Horizontal	1.53	49.6	-95.2	-45.6	-25	-20.6	Peak
5135	48.07	Vertical	1.53	49.6	-95.2	-45.6	-25	-20.6	Peak
7702.5	52.6	Horizontal	3.8	56.4	-95.2	-38.8	-25	-13.8	Peak
7702.5	52.9	Vertical	3.8	56.7	-95.2	-38.5	-25	-13.5	Peak

Frequency (MHz)	Reading level (dB μ V)	Polar (H/V)	Corrected Factor (dB/m)	Corrected Amplitude (dB μ V/m)	EIRP CF	Corrected Reading (dBm)	Limit (dBm)	Margin (dB)	Remark
LTE B12									
Low Channel									
1399.4	47.25	Horizontal	-3.95	43.3	-95.2	-51.9	-13	-38.9	Peak
1399.4	45.75	Vertical	-3.95	41.8	-95.2	-53.4	-13	-40.4	Peak
2099.1	46.06	Horizontal	-2.76	43.3	-95.2	-51.9	-13	-38.9	Peak
2099.1	46.16	Vertical	-2.76	43.4	-95.2	-51.8	-13	-38.8	Peak
2798.8	44.39	Horizontal	-1.39	43	-95.2	-52.2	-13	-39.2	Peak
2798.8	45.19	Vertical	-1.39	43.8	-95.2	-51.4	-13	-38.4	Peak
Middle Channel									
1415	47.66	Horizontal	-3.86	43.8	-95.2	-51.4	-13	-38.4	Peak
1415	46.06	Vertical	-3.86	42.2	-95.2	-53	-13	-40	Peak
2122.5	46.29	Horizontal	-2.69	43.6	-95.2	-51.6	-13	-38.6	Peak
2122.5	46.29	Vertical	-2.69	43.6	-95.2	-51.6	-13	-38.6	Peak
2830	45.13	Horizontal	-1.43	43.7	-95.2	-51.5	-13	-38.5	Peak
2830	45.63	Vertical	-1.43	44.2	-95.2	-51	-13	-38	Peak
High Channel									
1430.6	48.48	Horizontal	-3.78	44.7	-95.2	-50.5	-13	-37.5	Peak
1430.6	47.18	Vertical	-3.78	43.4	-95.2	-51.8	-13	-38.8	Peak
2145.9	47.02	Horizontal	-2.62	44.4	-95.2	-50.8	-13	-37.8	Peak
2145.9	47.12	Vertical	-2.62	44.5	-95.2	-50.7	-13	-37.7	Peak
2861.2	46	Horizontal	-1.5	44.5	-95.2	-50.7	-13	-37.7	Peak
2861.2	46.9	Vertical	-1.5	45.4	-95.2	-49.8	-13	-36.8	Peak

Frequency (MHz)	Reading level (dBμV)	Polar (H/V)	Corrected Factor (dB/m)	Corrected Amplitude (dBμV/m)	EIRP CF	Corrected Reading (dBm)	Limit (dBm)	Margin (dB)	Remark
LTE Band 41									
Low Channel									
5075	47.63	Horizontal	1.37	49	-95.2	-46.2	-25	-21.2	Peak
5075	47.33	Vertical	1.37	48.7	-95.2	-46.5	-25	-21.5	Peak
7612.5	51.49	Horizontal	3.31	54.8	-95.2	-40.4	-25	-15.4	Peak
7612.5	51.69	Vertical	3.31	55	-95.2	-40.2	-25	-15.2	Peak
Middle Channel(2595MHz)									
5190	47.93	Horizontal	1.67	49.6	-95.2	-45.6	-25	-20.6	Peak
5190	47.73	Vertical	1.67	49.4	-95.2	-45.8	-25	-20.8	Peak
7785	52.09	Horizontal	3.81	55.9	-95.2	-39.3	-25	-14.3	Peak
7785	52.19	Vertical	3.81	56	-95.2	-39.2	-25	-14.2	Peak
High Channel(2652.5MHz)									
5305	49.55	Horizontal	1.45	51	-95.2	-44.2	-25	-19.2	Peak
5305	49.15	Vertical	1.45	50.6	-95.2	-44.6	-25	-19.6	Peak
7957.5	52.85	Horizontal	4.05	56.9	-95.2	-38.3	-25	-13.3	Peak
7957.5	53.25	Vertical	4.05	57.3	-95.2	-37.9	-25	-12.9	Peak

Remark:

Corrected Amplitude= Reading level + corrected Factor

Corrected Factor = Antenna factor + Cable loss – Amplifier gain

Margin = Corrected Reading – Limit

According to ANSI C63.26-2.15 section 5.2.7:

$EIRP (dBm) = E (dB\mu V/m) + 20\log(D) - 104.8$; where D is the measurement distance (in the far field region) in m.

Test was performed on 3meters distance, so

Corrected Reading = Corrected Amplitude + $20\log(3) - 104.8$

= Corrected Amplitude - 95.2

The emission levels of other frequencies that were lower than the limit 20dB, not show in test report.

4 Test Setup Photo

Please refer to the attachment RWAZ202300123E Test Setup photo.

5 E.U.T Photo

Please refer to the attachment RWAZ202300123 External photo and RWAZ202300123 Internal photo.

---End of Report---