

3.6. Band edge and Spurious Emission (conducted)

LIMIT

FCC CFR Title 47 Part 15 Subpart C Section 15.247 (d):

In any 100 kHz bandwidth outside the frequency band in which the spread spectrum intentional radiator is operating, the radio frequency power that is produced by the intentional radiator shall be at least 20 dB below that in the 100 kHz bandwidth within the band that contains the highest level of the desired power, based on either an RF conducted or a radiated measurement.

TEST CONFIGURATION

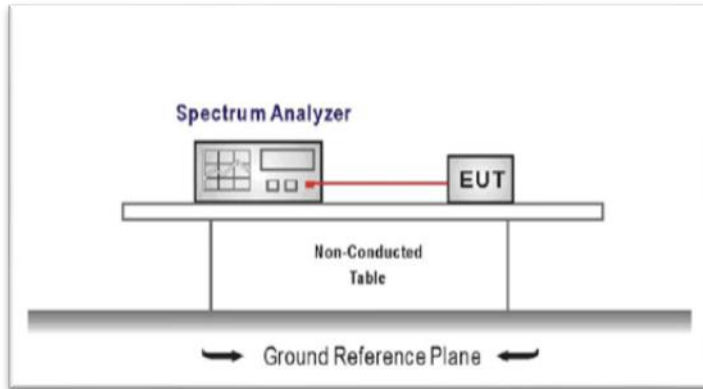

TEST PROCEDURE

1. Connect the antenna port(s) to the spectrum analyzer input.
2. Establish a reference level by using the following procedure
 - Center frequency=DTS channel center frequency
 - The span = 1.5 times the DTS bandwidth.
 - RBW = 100 kHz, VBW $\geq 3 \times$ RBW
 - Detector = peak, Sweep time = auto couple, Trace mode = max hold
 - Allow trace to fully stabilize
 - Use the peak marker function to determine the maximum PSD level

Note: the channel found to contain the maximum PSD level can be used to establish the reference level.
3. Emission level measurement
 - Set the center frequency and span to encompass frequency range to be measured
 - RBW = 100 kHz, VBW $\geq 3 \times$ RBW
 - Detector = peak, Sweep time = auto couple, Trace mode = max hold
 - Allow trace to fully stabilize
 - Use the peak marker function to determine the maximum amplitude level.
4. Place the radio in continuous transmit mode, allow the trace to stabilize, view the transmitter waveform on the spectrum analyzer.
5. Ensure that the amplitude of all unwanted emissions outside of the authorized frequency band excluding restricted frequency bands) are attenuated by at least the minimum requirements specified (at least 20 dB relative to the maximum in-band peak PSD level in 100 kHz). Report the three highest emissions relative to the limit.

TEST MODE:

Please refer to the clause 2.3.

TEST RESULTS

802.11b

CH01-Bandedge

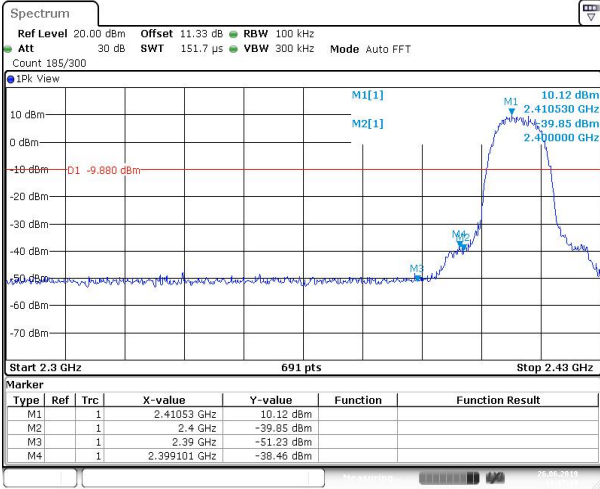

Date: 26 JUN 2019 13:17:19

CH11-Bandedge

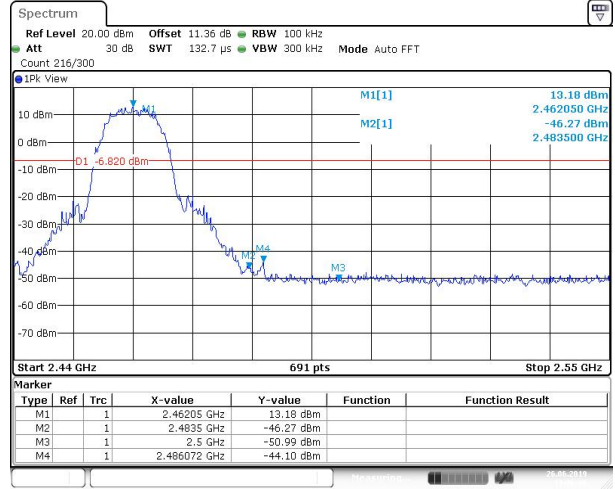

Date: 26 JUN 2019 13:26:25

802.11b

CH01-SE

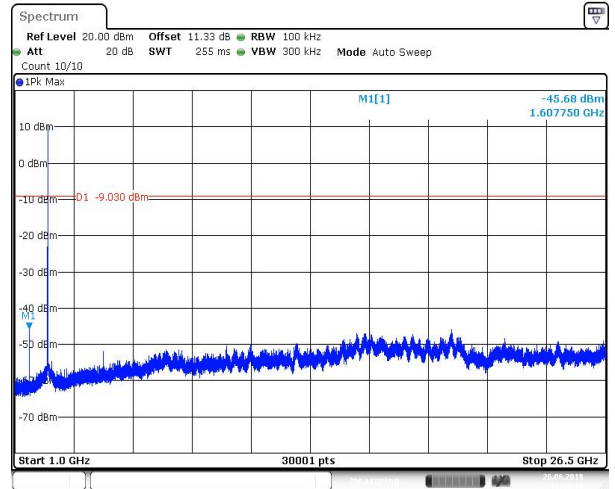
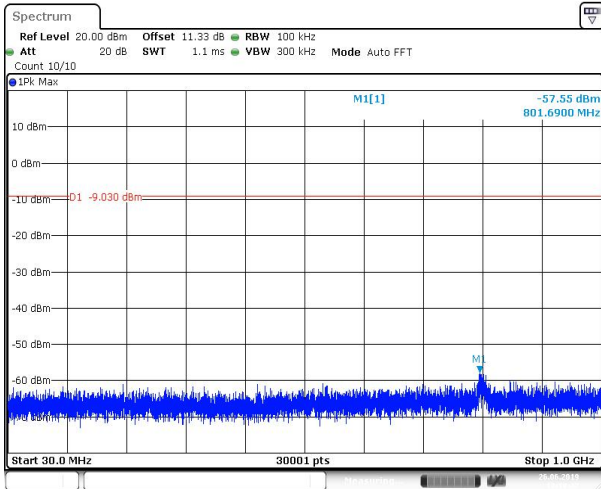

CH06-SE

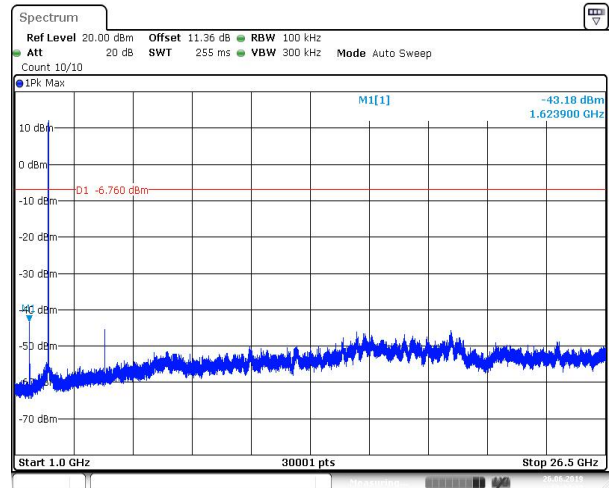
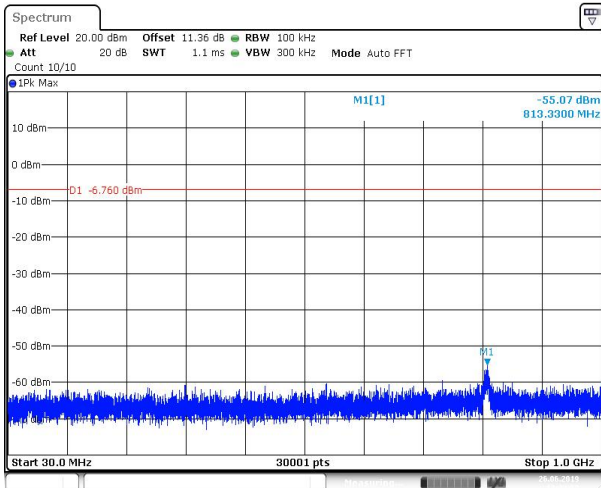

CH11-SE

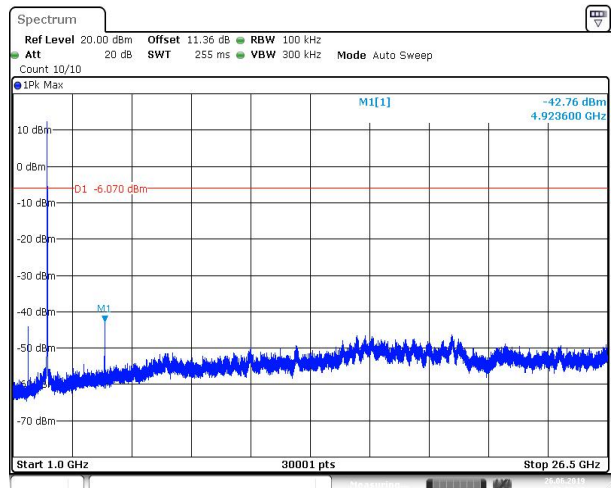
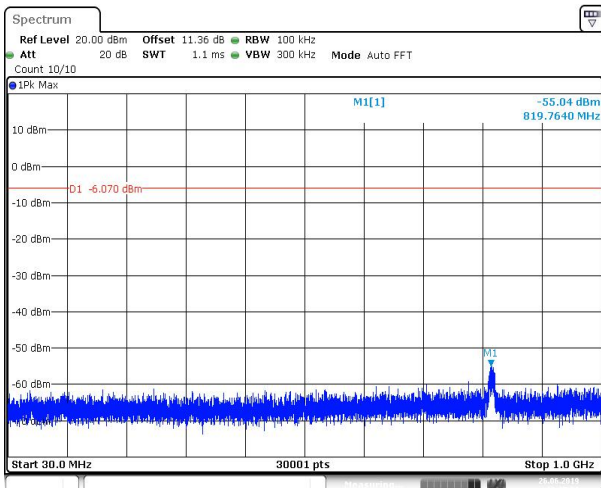

802.11g

CH01-Bandedge

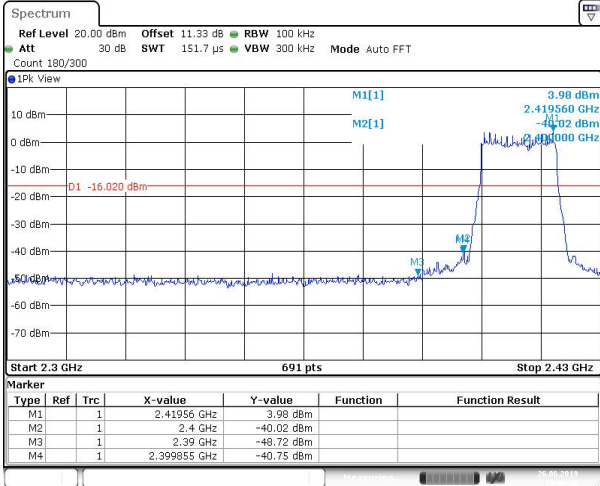

Date: 26 JUN 2019 13:36:29

CH11-Bandedge

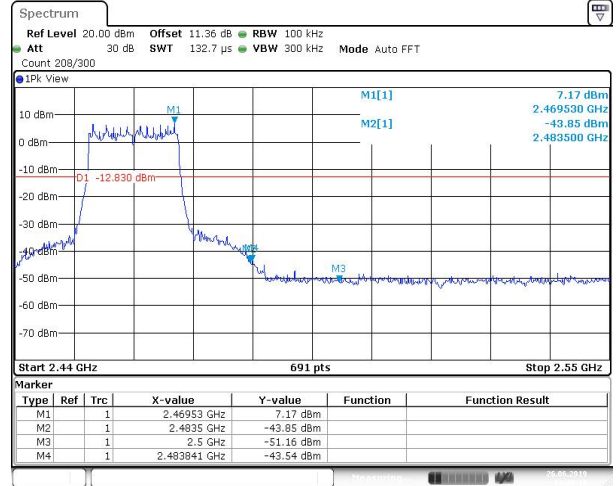

Date: 26 JUN 2019 13:48:19

802.11g

CH01-SE

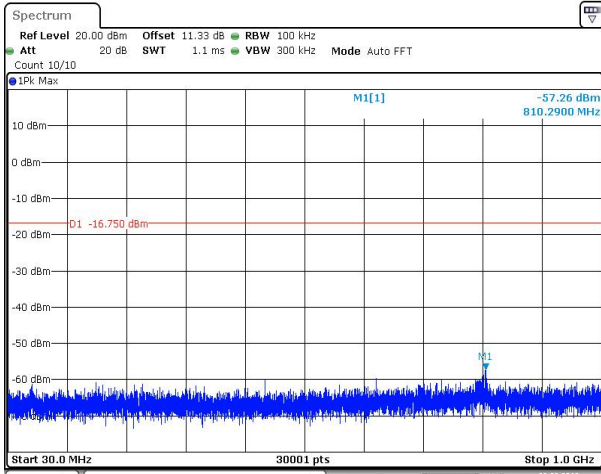

Date: 26 JUN. 2019 13:37:58

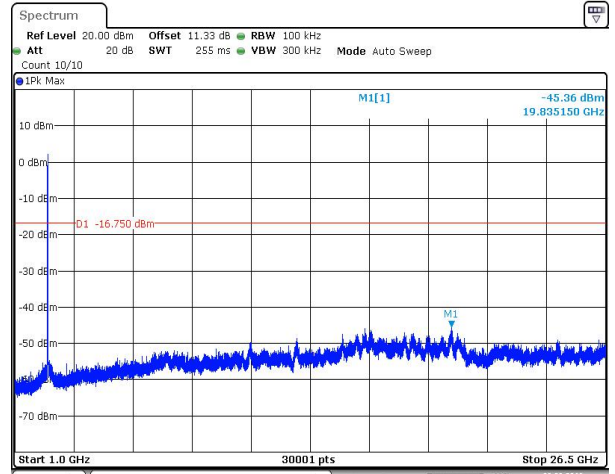

Date: 26 JUN. 2019 13:38:29

CH06-SE

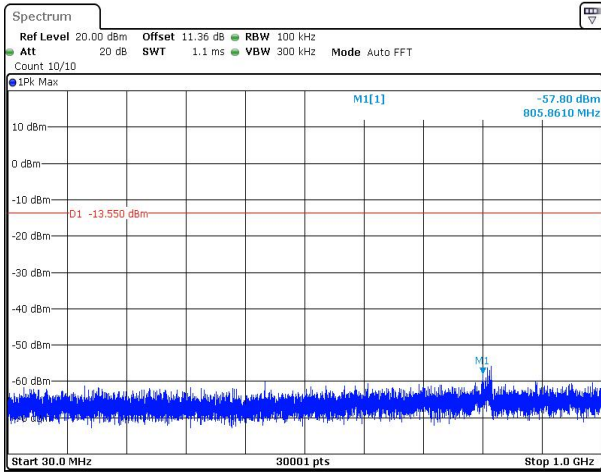

Date: 26 JUN. 2019 13:45:48

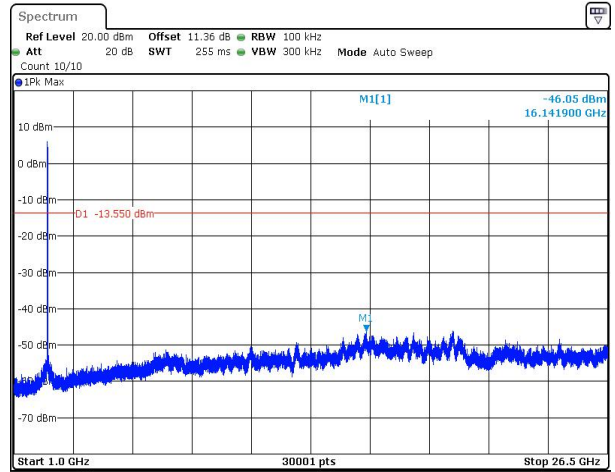

Date: 26 JUN. 2019 13:46:19

CH11-SE

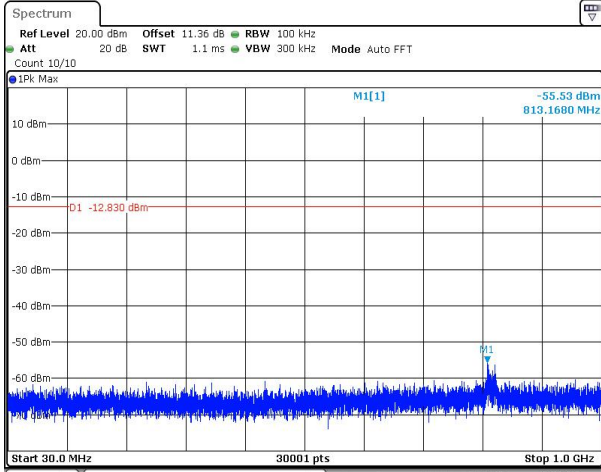

Date: 26 JUN. 2019 13:49:45

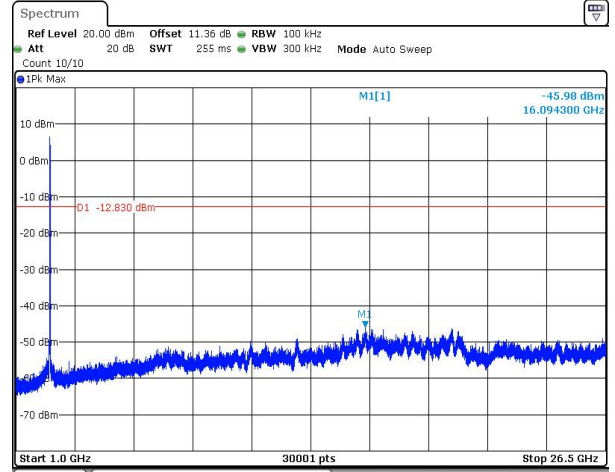

Date: 26 JUN. 2019 13:50:17

802.11n20

CH01-Bandedge

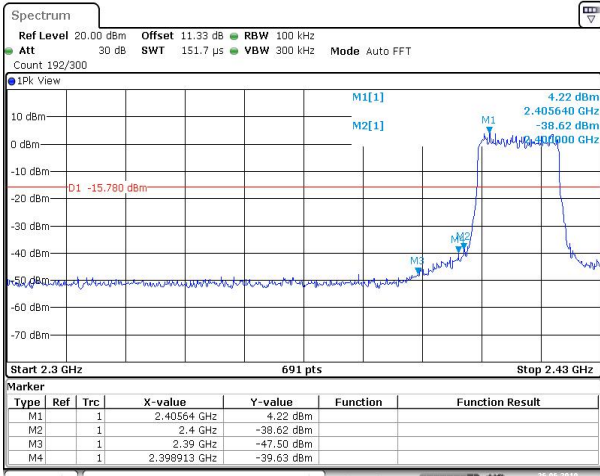

Date: 26 JUN 2019 13:52:22

CH11-Bandedge

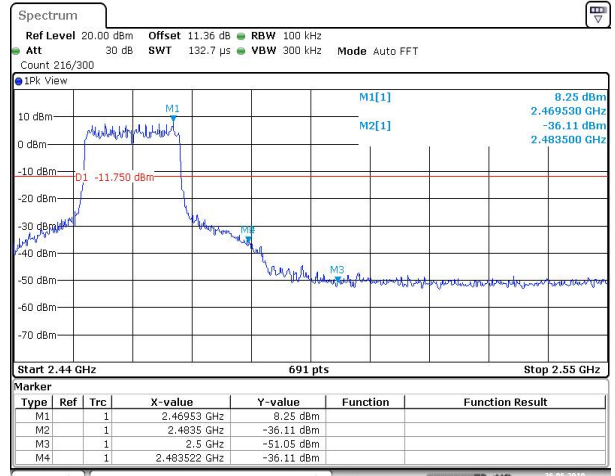

Date: 26 JUN 2019 14:00:42

802.11n20

CH01-SE

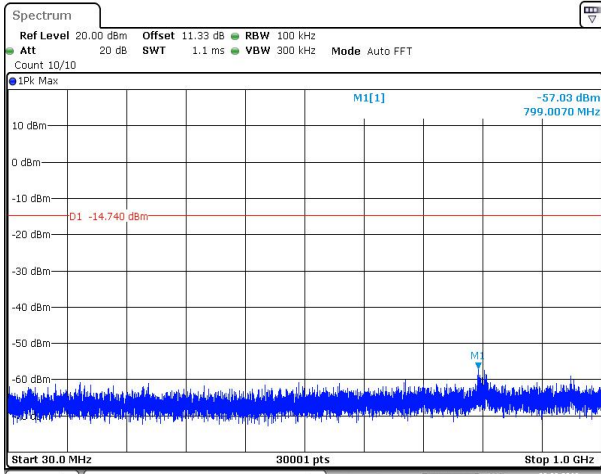

Date: 26 JUN.2019 13:53:50

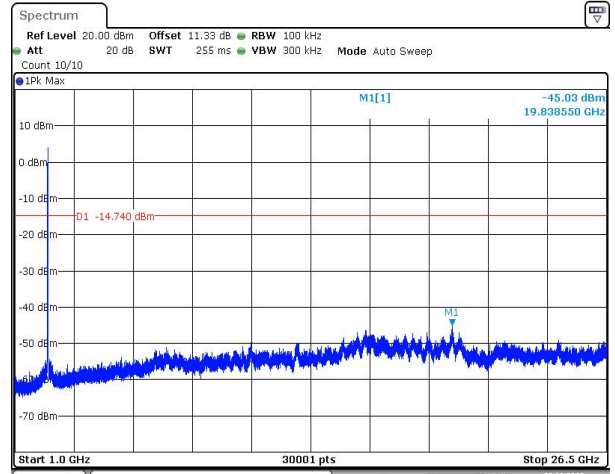

Date: 26 JUN.2019 13:54:22

CH06-SE

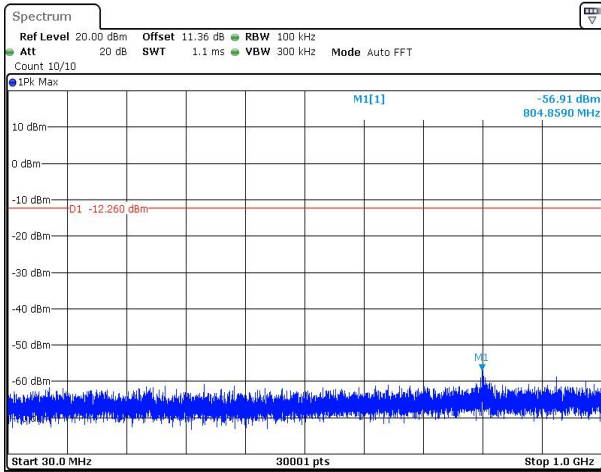

Date: 26 JUN.2019 13:58:06

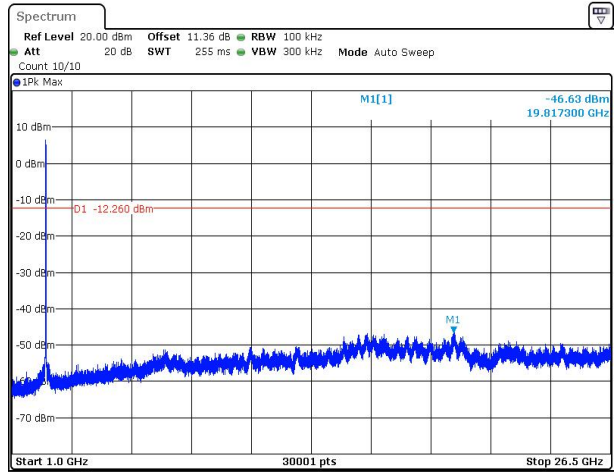

Date: 26 JUN.2019 13:58:37

CH11-SE

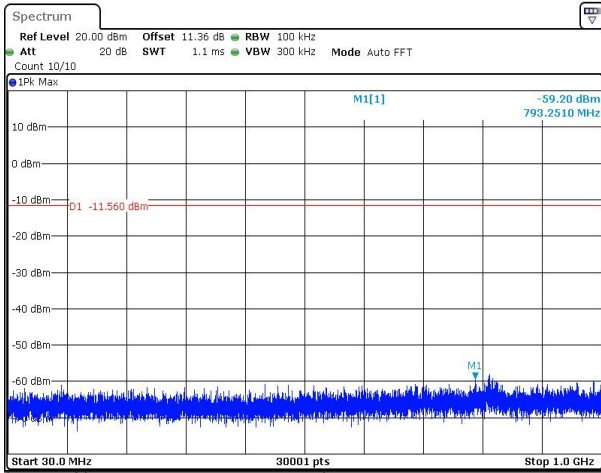

Date: 26 JUN.2019 14:02:08

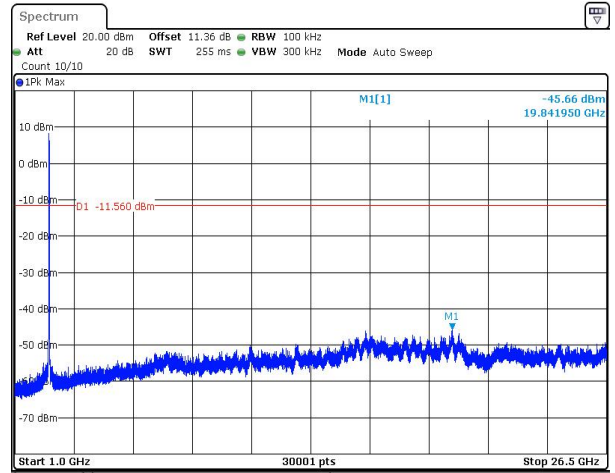

Date: 26 JUN.2019 14:02:39

802.11n40

CH03-Bandedge

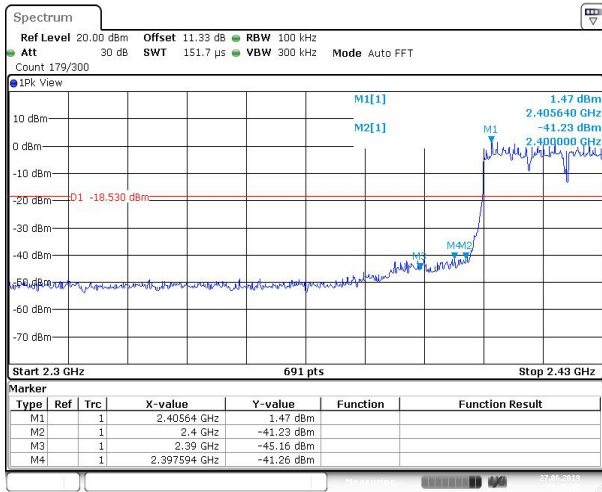

CH09-Bandedge

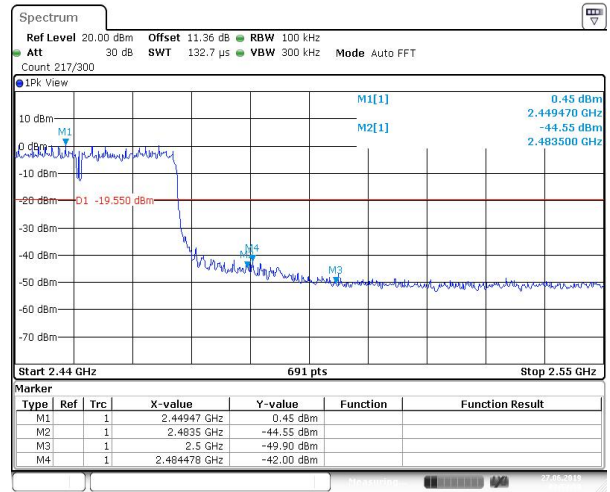

802.11n40

CH03-SE

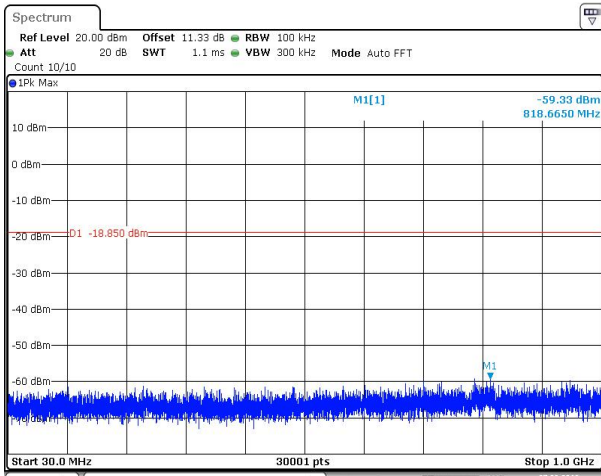

Date: 27 JUN 2019 03:47:07

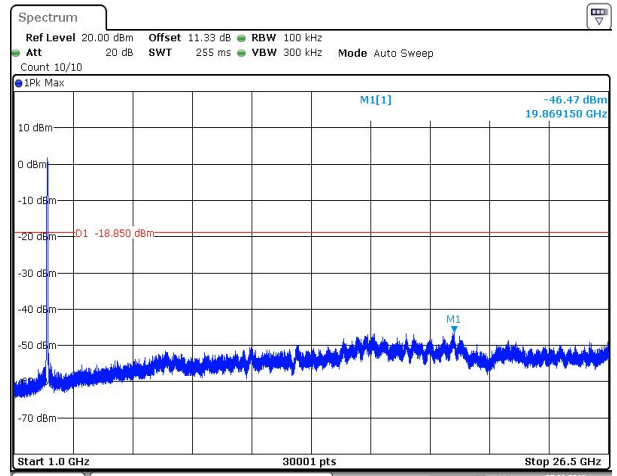

Date: 27 JUN 2019 03:47:39

CH06-SE

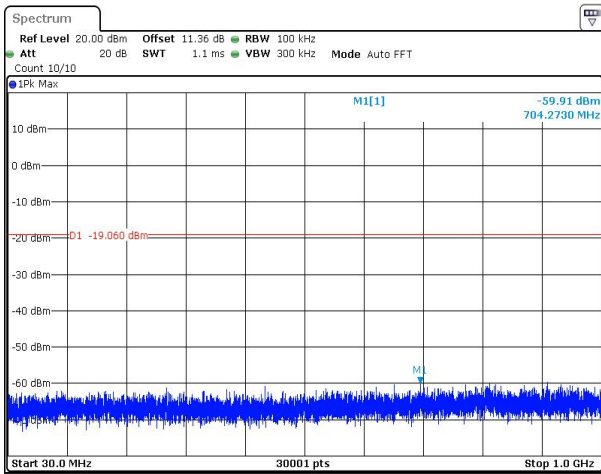

Date: 27 JUN 2019 03:51:24

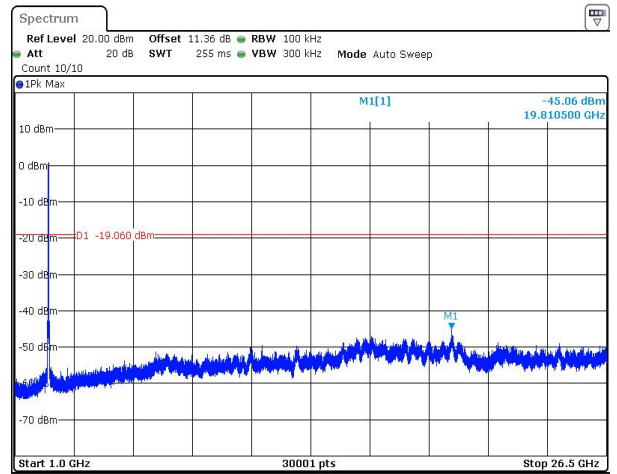

Date: 27 JUN 2019 03:51:56

CH09-SE

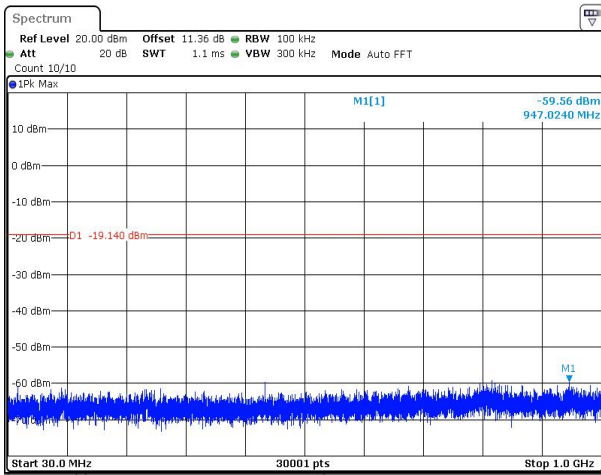

Date: 27 JUN 2019 03:55:27

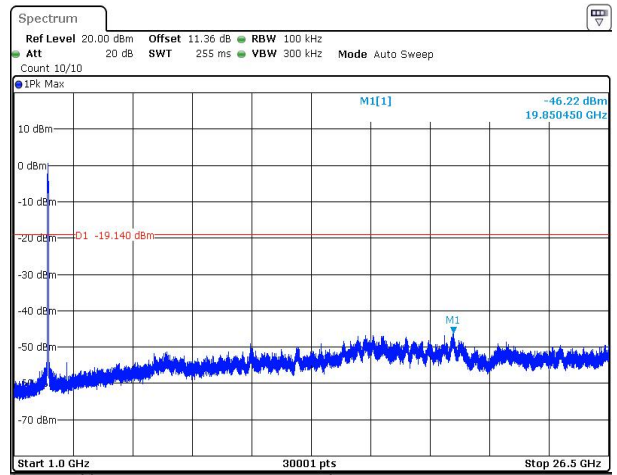

Date: 27 JUN 2019 03:55:58

3.7. Band Edge Emissions

Limit

Restricted Frequency Band (MHz)	(dBuV/m)(at 3m)	
	Peak	Average
2310 ~2390	74	54
2483.5 ~2500	74	54

Note: All restriction bands have been tested, only the worst case is reported.

Test Configuration

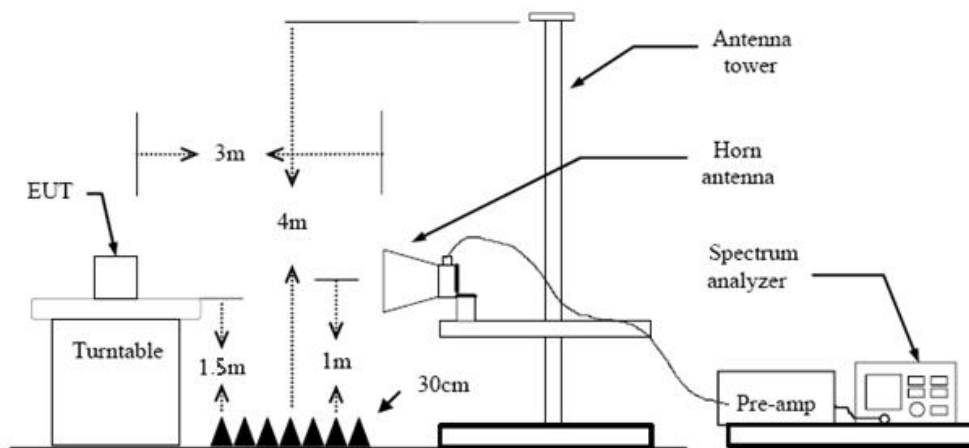

Test Procedure

1. The EUT was setup and tested according to ANSI C63.10:2013 requirements.
2. The EUT is placed on a turn table which is 1.5 meter above ground. The turn table is rotated 360 degrees to determine the position of the maximum emission level.
3. The EUT was positioned such that the distance from antenna to the EUT was 3 meters.
4. The antenna is scanned from 1 meter to 4 meters to find out the maximum emission level. This is repeated for both horizontal and vertical polarization of the antenna. In order to find the maximum emission, all of the interface cables were manipulated according to ANSI C63.10:2013 on radiated measurement.
5. The receiver set as follow:
 RBW=1MHz, VBW=3MHz PEAK detector for Peak value.
 RBW=1MHz, VBW=10Hz with PEAK Detector for Average Value.

Test Mode

Please refer to the clause 2.3.

Test Results **Passed** **Not Applicable**

Note:

- 1) Final level= Read level + Antenna Factor + Cable Loss - Preamp Factor
- 2) The amplitude of spurious emissions which are attenuated by more than 20dB below the permissible value has no need to be reported.

802.11b					CH01				
Frequency (MHz)	Read Level (dBuV)	Antenna Factor (dB/m)	Cable Loss (dB)	Preamp Factor (dB)	Level (dBuV/m)	Limit Line (dBuV/m)	Margin (dB)	Polarization	Test value
2310	19.68	26.01	4.52	0	50.21	74	-23.79	Vertical	Peak
2390	20.72	26.84	4.89	0	52.45	74	-21.55	Vertical	
2310	14.28	26.01	4.52	0	44.81	54	-9.19	Vertical	Average
2390	14.26	26.84	4.89	0	45.99	54	-8.01	Vertical	
2310	18.64	26.11	4.52	0	49.27	74	-24.73	Horizontal	Peak
2390	18.2	26.75	4.89	0	49.84	74	-24.16	Horizontal	
2310	15.41	26.11	4.52	0	46.04	54	-7.96	Horizontal	Average
2390	15.8	26.75	4.89	0	47.44	54	-6.56	Horizontal	

802.11b					CH11				
Frequency (MHz)	Read Level (dBuV)	Antenna Factor (dB/m)	Cable Loss (dB)	Preamp Factor (dB)	Level (dBuV/m)	Limit Line (dBuV/m)	Margin (dB)	Polarization	Test value
2483.76	21.2	26.01	4.52	0	51.73	74	-22.27	Vertical	Peak
2500	20.91	26.84	4.89	0	52.64	74	-21.36	Vertical	
2483.56	15.2	26.01	4.52	0	45.73	54	-8.27	Vertical	Average
2500	15.12	26.84	4.89	0	46.85	54	-7.15	Vertical	
2483.61	19.75	26.11	4.52	0	50.38	74	-23.62	Horizontal	Peak
2500	20.13	26.75	4.89	0	51.77	74	-22.23	Horizontal	
2483.66	15.42	26.11	4.52	0	46.05	54	-7.95	Horizontal	Average
2500	15.59	26.75	4.89	0	47.23	54	-6.77	Horizontal	

802.11g					CH01				
Frequency (MHz)	Read Level (dBuV)	Antenna Factor (dB/m)	Cable Loss (dB)	Preamplifier Factor (dB)	Level (dBuV/m)	Limit Line (dBuV/m)	Margin (dB)	Polarization	Test value
2310	23.1	26.01	4.52	0	53.63	74	-20.37	Vertical	Peak
2390	22.31	26.84	4.89	0	54.04	74	-19.96	Vertical	
2310	18.13	26.01	4.52	0	48.66	54	-5.34	Vertical	Average
2390	16.2	26.84	4.89	0	47.93	54	-6.07	Vertical	
2310	19.69	26.11	4.52	0	50.32	74	-23.68	Horizontal	Peak
2390	20.25	26.75	4.89	0	51.89	74	-22.11	Horizontal	
2310	18.41	26.11	4.52	0	49.04	54	-4.96	Horizontal	Average
2390	15.56	26.75	4.89	0	47.2	54	-6.8	Horizontal	

802.11g					CH11				
Frequency (MHz)	Read Level (dBuV)	Antenna Factor (dB/m)	Cable Loss (dB)	Preamplifier Factor (dB)	Level (dBuV/m)	Limit Line (dBuV/m)	Margin (dB)	Polarization	Test value
2483.54	19.49	26.01	4.52	0	50.02	74	-23.98	Vertical	Peak
2500	20.18	26.84	4.89	0	51.91	74	-22.09	Vertical	
2483.85	15.7	26.01	4.52	0	46.23	54	-7.77	Vertical	Average
2500	15.55	26.84	4.89	0	47.28	54	-6.72	Vertical	
2483.67	19.6	26.11	4.52	0	50.23	74	-23.77	Horizontal	Peak
2500	20.36	26.75	4.89	0	52	74	-22	Horizontal	
2483.52	16.55	26.11	4.52	0	47.18	54	-6.82	Horizontal	Average
2500	16.79	26.75	4.89	0	48.43	54	-5.57	Horizontal	

802.11n(H20)					CH01				
Frequency (MHz)	Read Level (dBuV)	Antenna Factor (dB/m)	Cable Loss (dB)	Preamplifier Factor (dB)	Level (dBuV/m)	Limit Line (dBuV/m)	Margin (dB)	Polarization	Test value
2310	19.36	26.01	4.52	0	49.89	74	-24.11	Vertical	Peak
2390	20.48	26.84	4.89	0	52.21	74	-21.79	Vertical	
2310	20.32	26.01	4.52	0	50.85	54	-3.15	Vertical	Average
2390	19.3	26.84	4.89	0	51.03	54	-2.97	Vertical	
2310	19.4	26.11	4.52	0	50.03	74	-23.97	Horizontal	Peak
2390	20.38	26.75	4.89	0	52.02	74	-21.98	Horizontal	
2310	14.1	26.11	4.52	0	44.73	54	-9.27	Horizontal	Average
2390	14.31	26.75	4.89	0	45.95	54	-8.05	Horizontal	

802.11n(H20)					CH11				
Frequency (MHz)	Read Level (dBuV)	Antenna Factor (dB/m)	Cable Loss (dB)	Preamplifier Factor (dB)	Level (dBuV/m)	Limit Line (dBuV/m)	Margin (dB)	Polarization	Test value
2483.90	20.3	26.01	4.52	0	50.83	74	-23.17	Vertical	Peak
2500	20.59	26.84	4.89	0	52.32	74	-21.68	Vertical	
2483.73	16.2	26.01	4.52	0	46.73	54	-7.27	Vertical	Average
2500	16.1	26.84	4.89	0	47.83	54	-6.17	Vertical	
2483.64	18.44	26.11	4.52	0	49.07	74	-24.93	Horizontal	Peak
2500	20.3	26.75	4.89	0	51.94	74	-22.06	Horizontal	
2483.67	15.71	26.11	4.52	0	46.34	54	-7.66	Horizontal	Average
2500	15.49	26.75	4.89	0	47.13	54	-6.87	Horizontal	

802.11n(N40)					CH03				
Frequency (MHz)	Read Level (dBuV)	Antenna Factor (dB/m)	Cable Loss (dB)	Preamplifier Factor (dB)	Level (dBuV/m)	Limit Line (dBuV/m)	Margin (dB)	Polarization	Test value
2310	20.6	26.01	4.52	0	51.13	74	-22.87	Vertical	Peak
2390	20.31	26.84	4.89	0	52.04	74	-21.96	Vertical	
2310	15.2	26.01	4.52	0	45.73	54	-8.27	Vertical	Average
2390	14.1	26.84	4.89	0	45.83	54	-8.17	Vertical	
2310	20.82	26.11	4.52	0	51.45	74	-22.55	Horizontal	Peak
2390	21.4	26.75	4.89	0	53.04	74	-20.96	Horizontal	
2310	14.62	26.11	4.52	0	45.25	54	-8.75	Horizontal	Average
2390	15.3	26.75	4.89	0	46.94	54	-7.06	Horizontal	

802.11n(H40)					CH09				
Frequency (MHz)	Read Level (dBuV)	Antenna Factor (dB/m)	Cable Loss (dB)	Preamplifier Factor (dB)	Level (dBuV/m)	Limit Line (dBuV/m)	Margin (dB)	Polarization	Test value
2483.60	20.3	26.01	4.52	0	50.83	74	-23.17	Vertical	Peak
2500	20.61	26.84	4.89	0	52.34	74	-21.66	Vertical	
2483.60	14.62	26.01	4.52	0	45.15	54	-8.85	Vertical	Average
2500	14.8	26.84	4.89	0	46.53	54	-7.47	Vertical	
2483.60	20.41	26.11	4.52	0	51.04	74	-22.96	Horizontal	Peak
2500	21.51	26.75	4.89	0	53.15	74	-20.85	Horizontal	
2483.60	15.3	26.11	4.52	0	45.93	54	-8.07	Horizontal	Average
2500	15.65	26.75	4.89	0	47.29	54	-6.71	Horizontal	

3.8. Spurious Emission (Radiated)

Limit

Radiated Emission Limits (9 kHz~1000 MHz)

Frequency (MHz)	Field Strength (microvolt/meter)	Measurement Distance (meters)
0.009~0.490	2400/F(KHz)	300
0.490~1.705	24000/F(KHz)	30
1.705~30.0	30	30
30~88	100	3
88~216	150	3
216~960	200	3
Above 960	500	3

Radiated Emission Limit (Above 1000MHz)

Frequency (MHz)	Distance Meters(at 3m)	
	Peak	Average
Above 1000	74	54

Note:

- (1) The tighter limit applies at the band edges.
- (2) Emission Level (dBuV/m)=20log Emission Level (uV/m).

Test Configuration

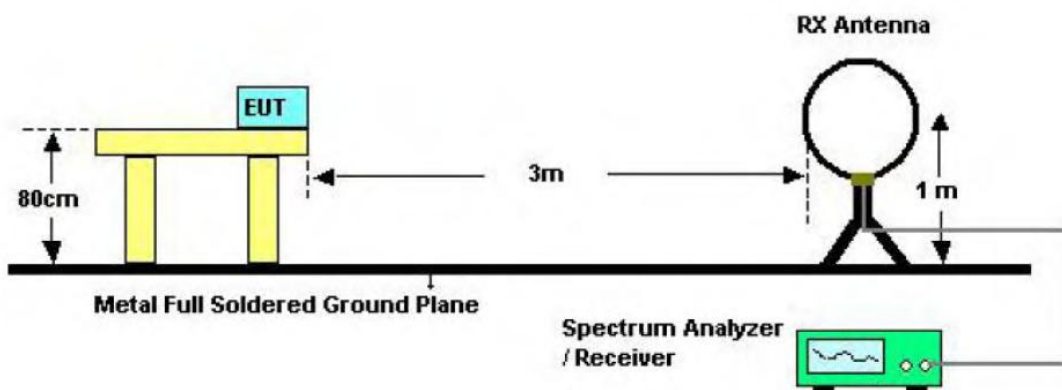

Below 30MHz Test Setup

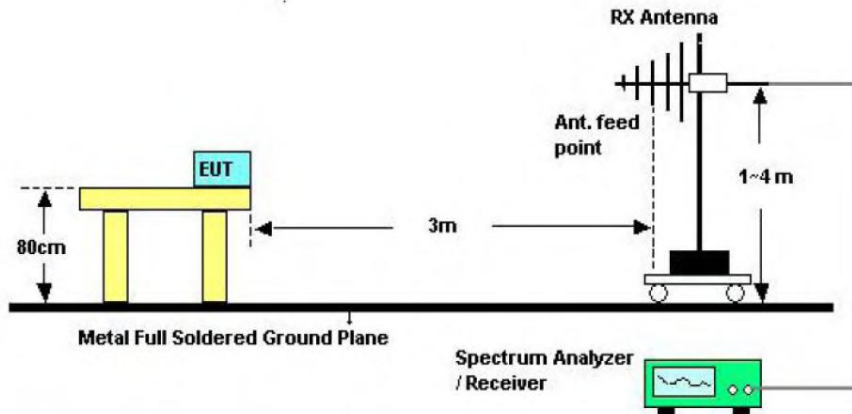

Below 1000MHz Test Setup

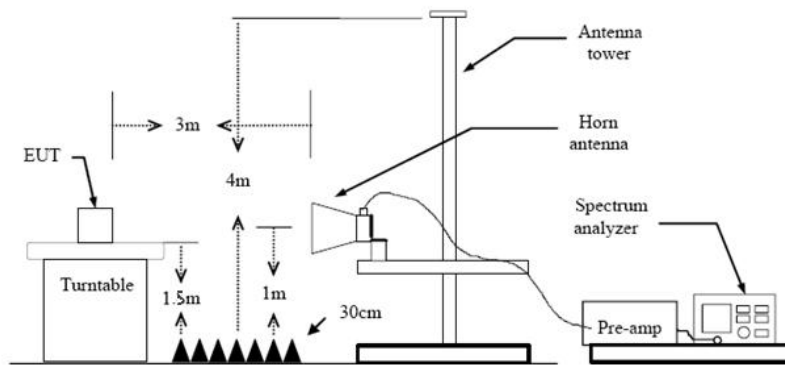

Above 1GHz Test Setup

Test Procedure

1. The EUT was setup and tested according to ANSI C63.10:2013
2. The EUT is placed on a turn table which is 0.8meter above ground for below 1 GHz, and 1.5m for above 1 GHz. The turn table is rotated 360 degrees to determine the position of the maximum emission level.
3. The EUT was set 3 meters from the receiving antenna, which was mounted on the top of a variable height antenna tower.
4. For each suspected emission, the EUT was arranged to its worst case and then tune the Antenna tower (from 1 m to 4 m) and turntable (from 0 degree to 360 degrees) to find the maximum reading. A pre-amp and a high pass filter are used for the test in order to get better signal level to comply with the guidelines.
5. Set to the maximum power setting and enable the EUT transmit continuously.
6. Use the following spectrum analyzer settings
 - (1) Span shall wide enough to fully capture the emission being measured;
 - (2) Below 1 GHz:
RBW=120 kHz, VBW=300 kHz, Sweep=auto, Detector function=peak, Trace=max hold;
If the emission level of the EUT measured by the peak detector is 3 dB lower than the applicable limit, the peak emission level will be reported. Otherwise, the emission measurement will be repeated using the quasi-peak detector and reported.
 - (3) From 1 GHz to 10th harmonic:
RBW=1MHz, VBW=3MHz Peak detector for Peak value.
RBW=1MHz, VBW=10Hz RMS detector for Average value.

Test Mode

Please refer to the clause 2.3.

Test Result

9 KHz~30 MHz and 18GHz~25GHz

From 9 KHz~30 MHz and 18GHz~25GHz: Conclusion: PASS

Note:

- 1) Final Level =Receiver Read level + Antenna Factor + Cable Loss – Preamplifier Factor
- 2) The emission levels of other frequencies are very lower than the limit and not show in test report.
- 3) The amplitude of spurious emissions which are attenuated by more than 20dB below the permissible value has no need to be reported.

30MHz-1GHz

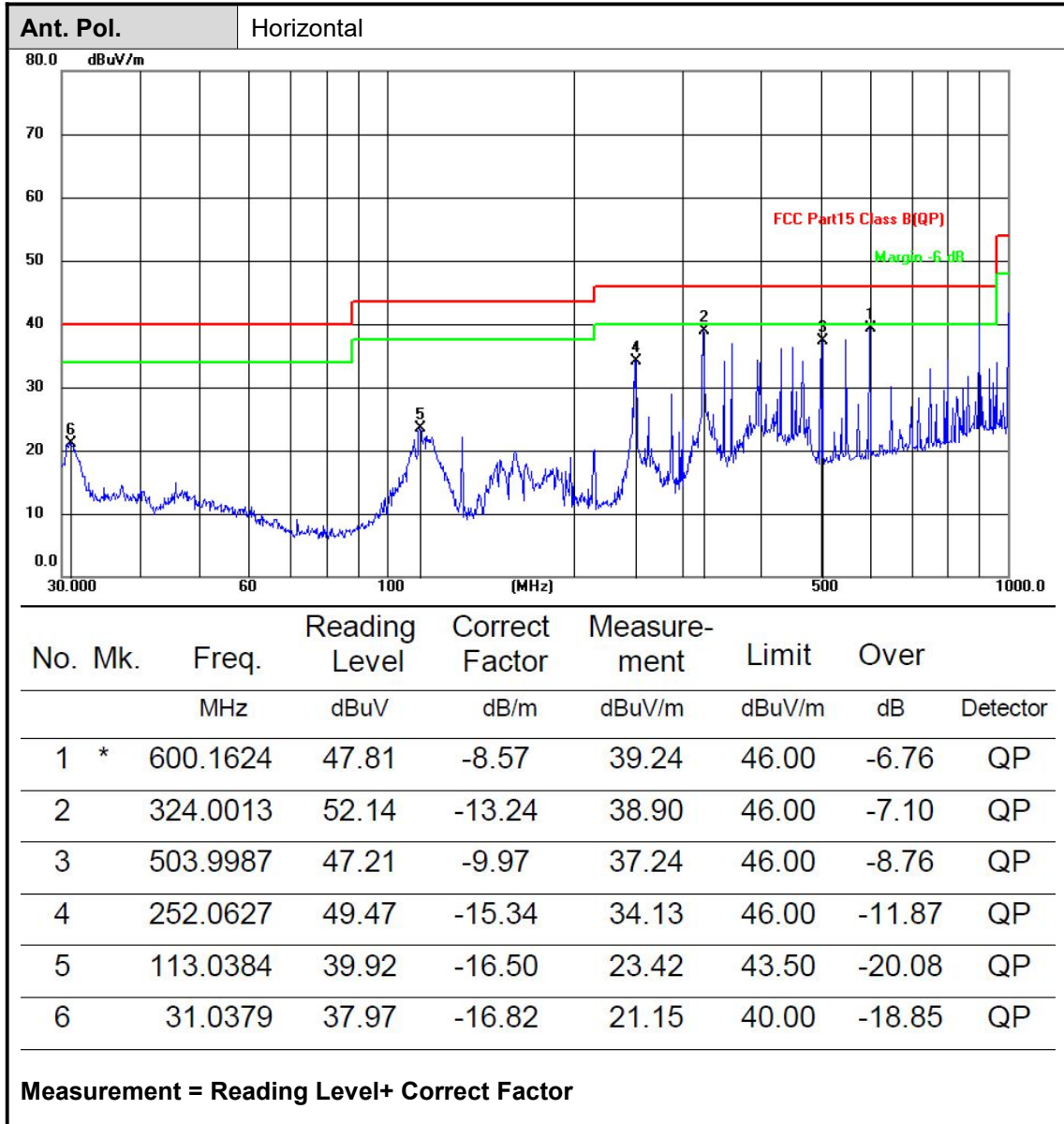

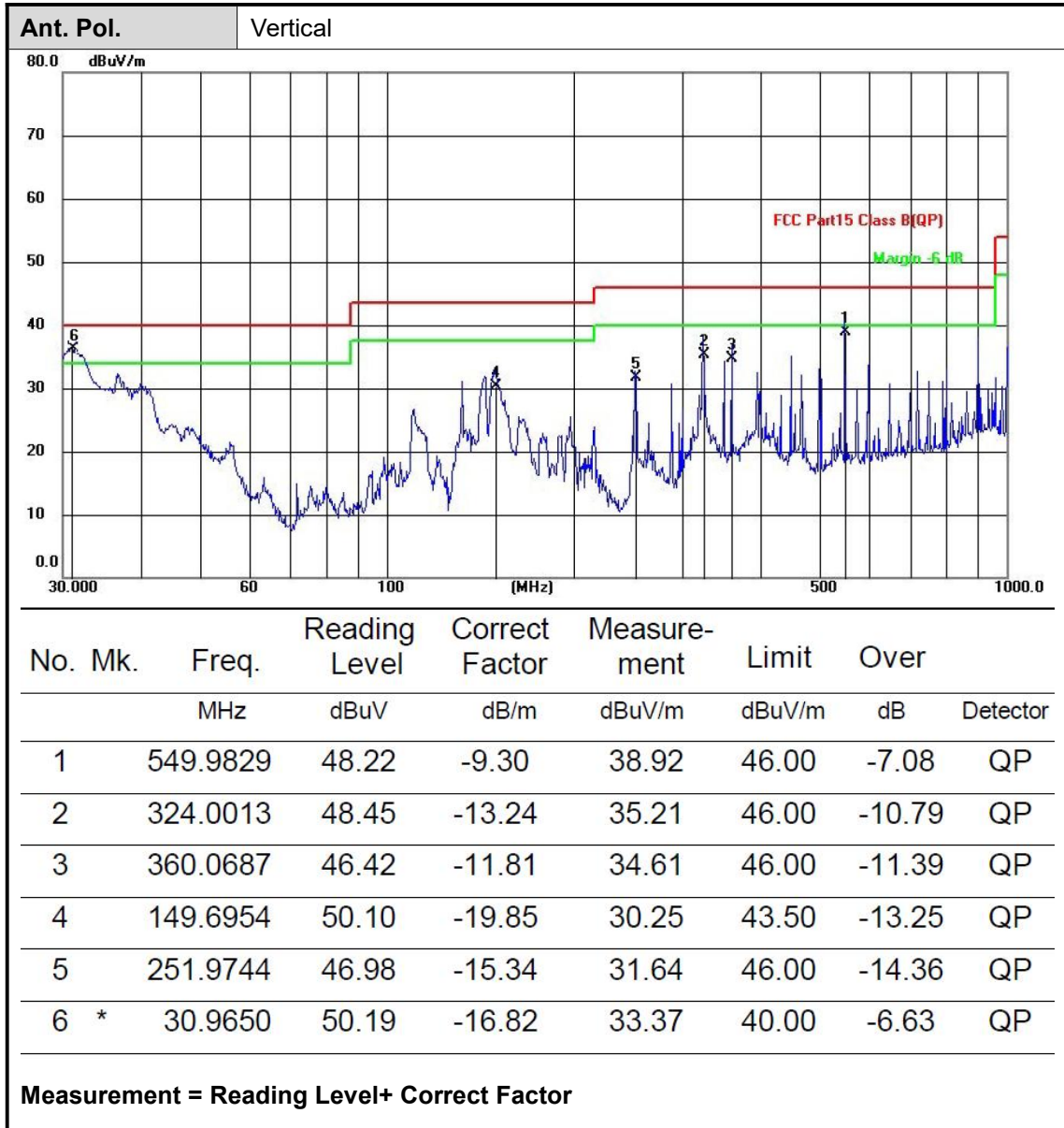

Adobe 1GHz

802.11b					CH01				
Frequency (MHz)	Read Level (dBuV)	Antenna Factor (dB/m)	Cable Loss (dB)	Preamplifier Factor (dB)	Final Level (dBuV/m)	Limit Line (dBuV/m)	Margin (dB)	Polarization	Test value
1593.45	41.25	24.99	3.36	26.38	43.22	74	-30.78	Vertical	Peak
2135.72	42.3	26.94	3.74	37.33	35.65	74	-38.35	Vertical	
4824.61	39.62	31.74	6.27	36.26	41.37	74	-32.63	Vertical	
6729.29	38.39	34.14	6.5	35.12	43.91	74	-30.09	Vertical	
1752.43	37.58	25.3	3.39	37.04	29.23	74	-44.77	Horizontal	
2126.70	39.64	26.94	3.68	37.33	32.93	74	-41.07	Horizontal	
4826.39	41.33	31.44	5.8	37.01	41.56	74	-32.44	Horizontal	
6628.14	40.52	34.2	6.74	35.31	46.15	74	-27.85	Horizontal	

802.11b					CH06				
Frequency (MHz)	Read Level (dBuV)	Antenna Factor (dB/m)	Cable Loss (dB)	Preamplifier Factor (dB)	Final Level (dBuV/m)	Limit Line (dBuV/m)	Margin (dB)	Polarization	Test value
1441.32	40.78	24.99	3.36	26.38	42.75	74	-31.25	Vertical	Peak
2120.74	41.53	26.94	3.74	37.33	34.88	74	-39.12	Vertical	
4874.48	37.67	31.74	6.27	36.26	39.42	74	-34.58	Vertical	
7586.22	39.3	34.14	6.5	35.12	44.82	74	-29.18	Vertical	
1750.82	39.14	25.3	3.39	37.04	30.79	74	-43.21	Horizontal	
2129.74	40.76	26.94	3.68	37.33	34.05	74	-39.95	Horizontal	
3578.61	38.89	31.44	5.8	37.01	39.12	74	-34.88	Horizontal	
4874.29	42.36	34.2	6.74	35.31	47.99	74	-26.01	Horizontal	

802.11b					CH11				
Frequency (MHz)	Read Level (dBuV)	Antenna Factor (dB/m)	Cable Loss (dB)	Preamplifier Factor (dB)	Final Level (dBuV/m)	Limit Line (dBuV/m)	Margin (dB)	Polarization	Test value
1209.42	41.67	24.99	3.36	26.38	43.64	74	-30.36	Vertical	Peak
2125.32	40.76	26.94	3.74	37.33	34.11	74	-39.89	Vertical	
4923.55	38.15	31.74	6.27	36.26	39.9	74	-34.1	Vertical	
7612.03	39.58	34.14	6.5	35.12	45.1	74	-28.9	Vertical	
1259.41	38.63	25.3	3.39	37.04	30.28	74	-43.72	Horizontal	
1706.39	40.75	26.94	3.68	37.33	34.04	74	-39.96	Horizontal	
3217.27	39.32	31.44	5.8	37.01	39.55	74	-34.45	Horizontal	
4923.58	42.93	34.2	6.74	35.31	48.56	74	-25.44	Horizontal	

802.11g					CH01				
Frequency (MHz)	Read Level (dBuV)	Antenna Factor (dB/m)	Cable Loss (dB)	Preamplifier Factor (dB)	Final Level (dBuV/m)	Limit Line (dBuV/m)	Margin (dB)	Polarization	Test value
1583.66	40.74	24.99	3.36	26.38	42.71	74	-31.29	Vertical	Peak
2133.73	40.21	26.94	3.74	37.33	33.56	74	-40.44	Vertical	
4824.83	38.73	31.74	6.27	36.26	40.48	74	-33.52	Vertical	
5633.21	39.82	34.14	6.5	35.12	45.34	74	-28.66	Vertical	
1592.57	39.39	25.3	3.39	37.04	31.04	74	-42.96	Horizontal	
2126.31	42.55	26.94	3.68	37.33	35.84	74	-38.16	Horizontal	
4824.2	41.4	31.44	5.8	37.01	41.63	74	-32.37	Horizontal	
6696.38	42.31	34.2	6.74	35.31	47.94	74	-26.06	Horizontal	

802.11g					CH06				
Frequency (MHz)	Read Level (dBuV)	Antenna Factor (dB/m)	Cable Loss (dB)	Preamplifier Factor (dB)	Final Level (dBuV/m)	Limit Line (dBuV/m)	Margin (dB)	Polarization	Test value
1644.31	41.21	24.99	3.36	26.38	43.18	74	-30.82	Vertical	Peak
2134.27	40.63	26.94	3.74	37.33	33.98	74	-40.02	Vertical	
4824.43	39.51	31.74	6.27	36.26	41.26	74	-32.74	Vertical	
5527.69	38.32	34.14	6.5	35.12	43.84	74	-30.16	Vertical	
1598.77	40.26	25.3	3.39	37.04	31.91	74	-42.09	Horizontal	
2120.63	41.58	26.94	3.68	37.33	34.87	74	-39.13	Horizontal	
4824.7	42.64	31.44	5.8	37.01	42.87	74	-31.13	Horizontal	
5112.83	43.19	34.2	6.74	35.31	48.82	74	-25.18	Horizontal	

802.11g					CH11				
Frequency (MHz)	Read Level (dBuV)	Antenna Factor (dB/m)	Cable Loss (dB)	Preamplifier Factor (dB)	Final Level (dBuV/m)	Limit Line (dBuV/m)	Margin (dB)	Polarization	Test value
1588.23	42.32	24.99	3.36	26.38	44.29	74	-29.71	Vertical	Peak
3181.45	41.23	26.94	3.74	37.33	34.58	74	-39.42	Vertical	
4824.3	39.42	31.74	6.27	36.26	41.17	74	-32.83	Vertical	
6592.1	38.93	34.14	6.5	35.12	44.45	74	-29.55	Vertical	
1588.73	40.23	25.3	3.39	37.04	31.88	74	-42.12	Horizontal	
1684.66	41.55	26.94	3.68	37.33	34.84	74	-39.16	Horizontal	
2119.47	42.71	31.44	5.8	37.01	42.94	74	-31.06	Horizontal	
4824.31	43.22	34.2	6.74	35.31	48.85	74	-25.15	Horizontal	

802.11n(H20)					CH01				
Frequency (MHz)	Read Level (dBuV)	Antenna Factor (dB/m)	Cable Loss (dB)	Preamplifier Factor (dB)	Final Level (dBuV/m)	Limit Line (dBuV/m)	Margin (dB)	Polarization	Test value
1684.25	42.52	24.99	3.36	26.38	44.49	74	-29.51	Vertical	Peak
2145.39	41.66	26.94	3.74	37.33	35.01	74	-38.99	Vertical	
4824.67	38.38	31.74	6.27	36.26	40.13	74	-33.87	Vertical	
6954.18	38.62	34.14	6.5	35.12	44.14	74	-29.86	Vertical	
1705.23	40.24	25.3	3.39	37.04	31.89	74	-42.11	Horizontal	
3184.85	41.4	26.94	3.68	37.33	34.69	74	-39.31	Horizontal	
4824.66	42.76	31.44	5.8	37.01	42.99	74	-31.01	Horizontal	
6997.39	41.33	34.2	6.74	35.31	46.96	74	-27.04	Horizontal	

802.11n(H20)					CH06				
Frequency (MHz)	Read Level (dBuV)	Antenna Factor (dB/m)	Cable Loss (dB)	Preamp Factor (dB)	Level (dBuV/m)	Limit Line (dBuV/m)	Margin (dB)	Polarization	Test value
1749.38	41.36	24.99	3.36	26.38	43.33	74	-30.67	Vertical	Peak
2253.75	42.88	26.94	3.74	37.33	36.23	74	-37.77	Vertical	
4824.45	39.42	31.74	6.27	36.26	41.17	74	-32.83	Vertical	
7238.44	38.31	34.14	6.5	35.12	43.83	74	-30.17	Vertical	
1758.67	40.53	25.3	3.39	37.04	32.18	74	-41.82	Horizontal	
3157.79	42.41	26.94	3.68	37.33	35.7	74	-38.3	Horizontal	
4824.48	40.76	31.44	5.8	37.01	40.99	74	-33.01	Horizontal	
6974.44	42.55	34.2	6.74	35.31	48.18	74	-25.82	Horizontal	

802.11n(H20)					CH11				
Frequency (MHz)	Read Level (dBuV)	Antenna Factor (dB/m)	Cable Loss (dB)	Preamplifier Factor (dB)	Final Level (dBuV/m)	Limit Line (dBuV/m)	Margin (dB)	Polarization	Test value
2196.72	40.63	24.99	3.36	26.38	42.6	74	-31.4	Vertical	Peak
3188.69	41.64	26.94	3.74	37.33	34.99	74	-39.01	Vertical	
4824.17	39.51	31.74	6.27	36.26	41.26	74	-32.74	Vertical	
6881.23	38.27	34.14	6.5	35.12	43.79	74	-30.21	Vertical	
1238.35	40.38	25.3	3.39	37.04	32.03	74	-41.97	Horizontal	
1664.46	42.6	26.94	3.68	37.33	35.89	74	-38.11	Horizontal	
4824.55	41.23	31.44	5.8	37.01	41.46	74	-32.54	Horizontal	
6994.46	42.37	34.2	6.74	35.31	48	74	-26	Horizontal	

802.11n(H40)					CH03				
Frequency (MHz)	Read Level (dBuV)	Antenna Factor (dB/m)	Cable Loss (dB)	Preamplifier Factor (dB)	Final Level (dBuV/m)	Limit Line (dBuV/m)	Margin (dB)	Polarization	Test value
1684.39	41.43	24.99	3.36	26.38	43.4	74	-30.6	Vertical	Peak
2146.44	39.49	26.94	3.74	37.33	32.84	74	-41.16	Vertical	
4824.58	36.26	31.74	6.27	36.26	38.01	74	-35.99	Vertical	
6953.46	38.38	34.14	6.5	35.12	43.9	74	-30.1	Vertical	
1707.77	41.47	25.3	3.39	37.04	33.12	74	-40.88	Horizontal	
3184.23	42.35	26.94	3.68	37.33	35.64	74	-38.36	Horizontal	
4824.5	39.56	31.44	5.8	37.01	39.79	74	-34.21	Horizontal	
6997.78	42.29	34.2	6.74	35.31	47.92	74	-26.08	Horizontal	

802.11n(H40)					CH06				
Frequency (MHz)	Read Level (dBuV)	Antenna Factor (dB/m)	Cable Loss (dB)	Preamplifier Factor (dB)	Final Level (dBuV/m)	Limit Line (dBuV/m)	Margin (dB)	Polarization	Test value
1748.28	40.52	24.99	3.36	26.38	42.49	74	-31.51	Vertical	Peak
2250.44	39.6	26.94	3.74	37.33	32.95	74	-41.05	Vertical	
4824.73	37.31	31.74	6.27	36.26	39.06	74	-34.94	Vertical	
7237.52	38.17	34.14	6.5	35.12	43.69	74	-30.31	Vertical	
1758.61	40.25	25.3	3.39	37.04	31.9	74	-42.1	Horizontal	
3157.59	41.29	26.94	3.68	37.33	34.58	74	-39.42	Horizontal	
4824.34	37.33	31.44	5.8	37.01	37.56	74	-36.44	Horizontal	
6974.26	40.27	34.2	6.74	35.31	45.9	74	-28.1	Horizontal	

802.11n(H40)					CH09				
Frequency (MHz)	Read Level (dBuV)	Antenna Factor (dB/m)	Cable Loss (dB)	Preamplifier Factor (dB)	Final Level (dBuV/m)	Limit Line (dBuV/m)	Margin (dB)	Polarization	Test value
2198.45	40.48	24.99	3.36	26.38	42.45	74	-31.55	Vertical	Peak
3189.38	39.96	26.94	3.74	37.33	33.31	74	-40.69	Vertical	
4824.67	37.73	31.74	6.27	36.26	39.48	74	-34.52	Vertical	
6882.23	38.58	34.14	6.5	35.12	44.1	74	-29.9	Vertical	
1249.75	41.67	25.3	3.39	37.04	33.32	74	-40.68	Horizontal	
1665.39	41.42	26.94	3.68	37.33	34.71	74	-39.29	Horizontal	
4824.26	37.78	31.44	5.8	37.01	38.01	74	-35.99	Horizontal	
6994.88	42.6	34.2	6.74	35.31	48.23	74	-25.77	Horizontal	

Remark:

1. Final Level = Read level + Antenna Factor + Cable Loss - Preamplifier Factor
2. The peak level is lower than average limit(54 dBuV/m), this data is the too weak instrument of signal is unable to test.
3. The emission levels of other frequencies are very lower than the limit and not show in test report.

4.EUT TEST PHOTOS

Reference to the document No.: Test Photos.

5. PHOTOGRAPHS OF EUT CONSTRUCTIONAL

Reference to the document No.: External Photos and Internal Photos.

*****THE END*****