



# SEREONIC<sup>®</sup>

## TV-SOUNDBOX

### OPERATING GUIDE

---

Thank you for purchasing this product.  
Please read before use.

Keep this manual for future reference.

## MODEL BT-200PRO



---

Thank you for purchasing the SEREONIC TV-SoundBox. Please read this operating guide carefully before use and keep it for future reference. If you have any questions, please free to contact our Customer Support Department

**Toll-Free Help Line: 866-376-9271 (8AM-5PM PST; M-F)**

## **IMPORTANT SAFETY INSTRUCTIONS:**

Please read these instructions carefully before using the SEREONIC TV-SoundBox.

- Always keep the system dry. Do not immerse in water.
- For your safety, do not attempt to open the unit. Attempting to open the unit violates your warranty.
- SEREONIC TV-SoundBox use a standard 18650 type Lithium-Ion battery. Please observe the safety and handling instructions for the lithium-ion batteries. Please dispose of the unit/used batteries properly, following local regulations. Do not dispose of the unit/used batteries in the household trash. Do not incinerate. Take the equipment to a nearby recycle center.
- Do not unplug by pulling on power cord. To unplug, grasp the plug, not the power cord. Unplug from outlet before servicing or cleaning. Do not operate any device with a

damaged cord or plug, or after the device malfunctions, or is dropped or damaged in any manner. Return device to the nearest authorized service facility for examination, repair or electrical or mechanical adjustment.

## **INTRODUCTION:**

This installation guide will provide you with clear and concise steps to connect the wireless TV speaker base to your audio source, such as a TV or Satellite/Cable box. Please follow the instructions on page 4 carefully to ensure proper setup and functionality of your wireless speaker system.

# PACKAGE CONTENT CHECK:

Wireless Receiver (Speaker)



Transmitter Base



Digital Optical Cord\*  
\*(Please remove plastic cap from Optical cord tips)



Analog Audio Cord  
(3.5mm male to male)



RCA to 3.5mm adapter



AC Adapter



Operating Guide

# PRODUCT FEATURES:

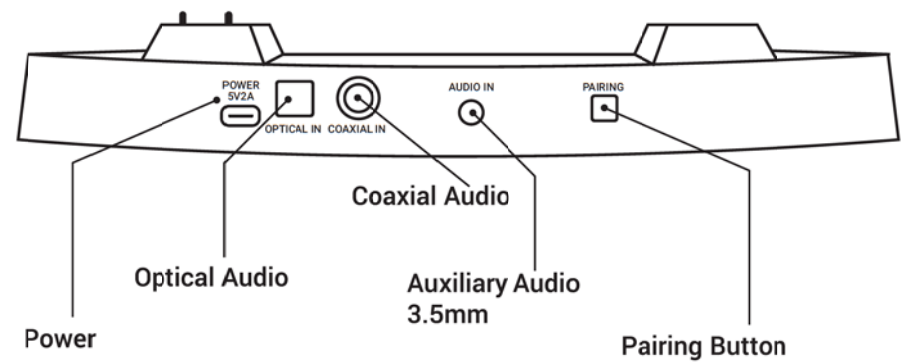
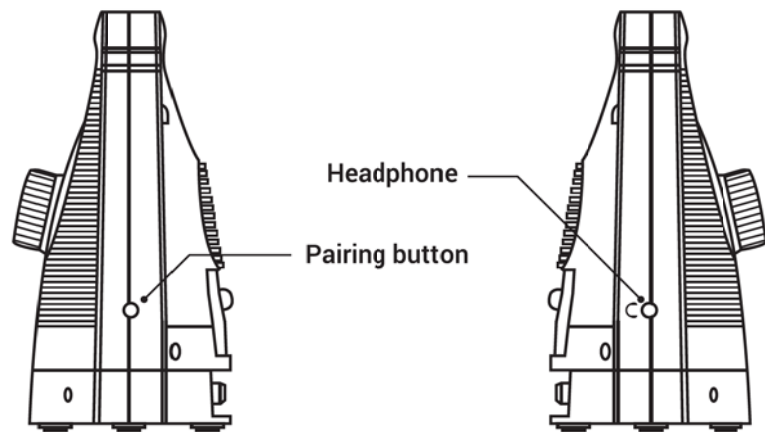
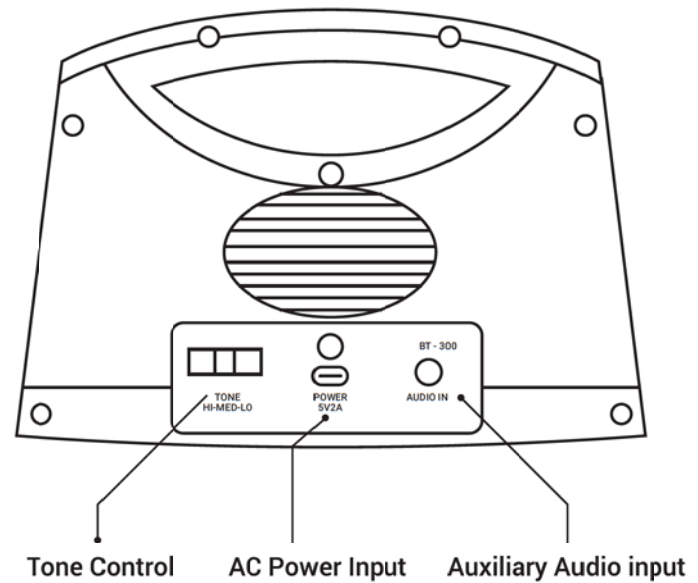
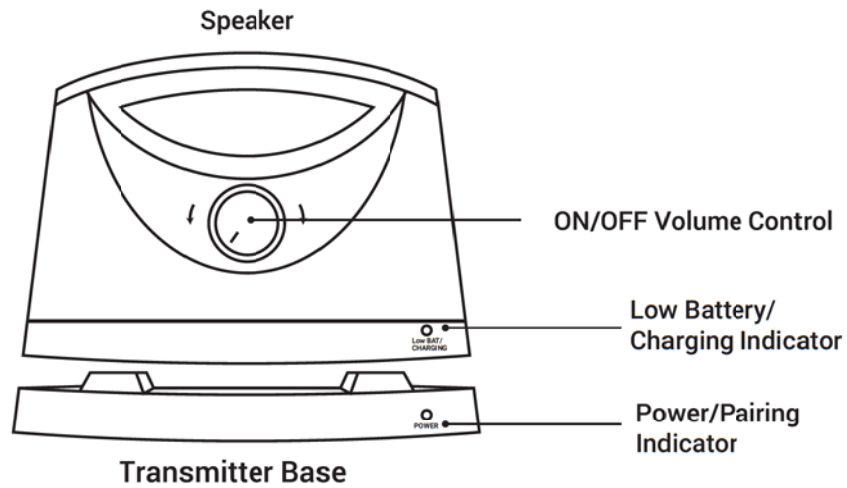

## CONNECTION & SETUP:

Please follow step 1 & 2 below to identify the type of connection available on the back of your TV or Satellite/Cable box to connect your Wireless TV Speaker. Please use only 1 type of connection from the options listed below.

### 01 Identify your audio source's output options

Before you begin, you will need to identify which audio output is available on your device (TV or Satellite/Cable box). Look for the following output options on your device:

- Optical output (also known as TOSLINK or S/PDIF)  
**Note: If Optical output is taken up by another device, you may use an optical splitter (sold separately) to connect your wireless TV speaker base. Refer to page 5 section A2**
- Coaxial output
- Analog audio output (Red & White RCA connection)  
**Note: If RCA output is taken up by another device, you may use an RCA splitter (sold separately) to connect your wireless TV speaker base. Refer to page 7 section C2**
- 3.5 mm audio output (also known as an auxiliary or headphone jack)

### 02 Select the appropriate input on the base

Once you have identified your audio source's output option in step 1, select the corresponding input on the base of your wireless TV speaker system. The base has the following input options:

- Optical input (for TOSLINK or S/PDIF)
- Coaxial input
- 3.5mm audio input

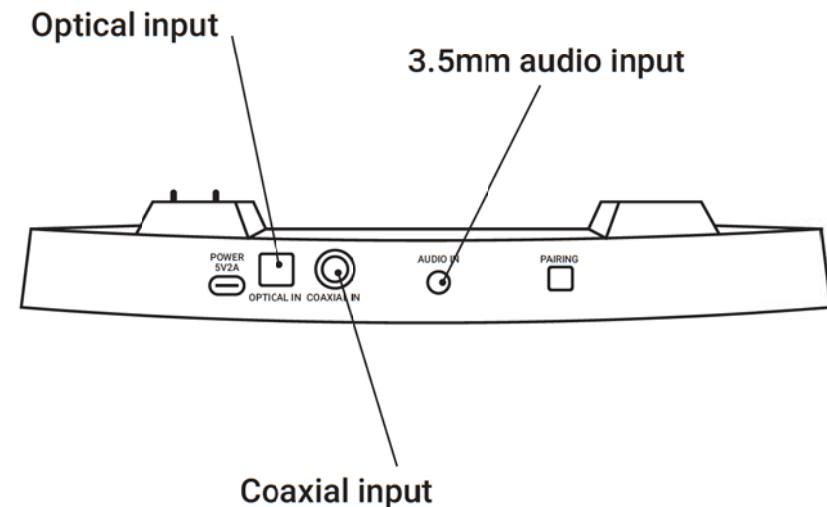

### 03 Connect the audio source to the base:

Now that you have identified the appropriate output on your audio source and the corresponding input on the base, it's time to connect them. Use the appropriate cable and connection type for your connection. *Only use one connection type.*

#### A1 Optical connection:

1. Locate the optical cable that is included in the box.
2. Remove the plastic caps on both ends of the cable.
3. Connect the optical cable as shown below.

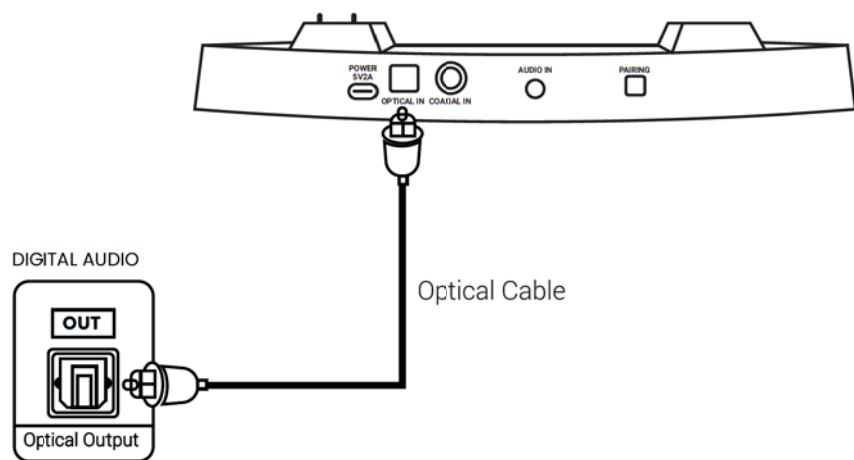

Back of your TV or  
Satellite/Cable box

#### A2 Optical connection using optical splitter

If your optical output from your TV or Satellite/Cable box is already connected to another device, you will require an optical splitter as shown below (Optical splitter is sold separately).

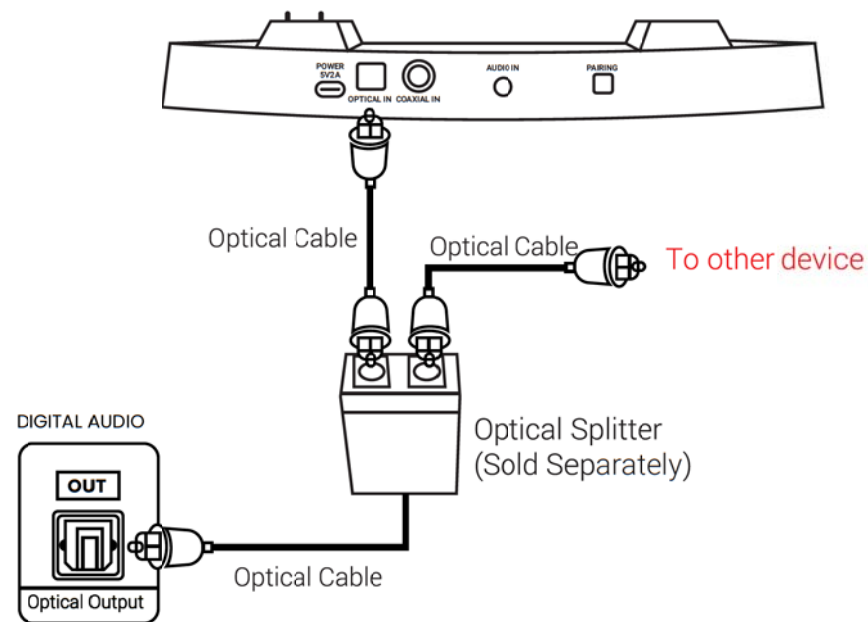

Back of your TV or  
Satellite/Cable box

## B Coaxial Connection

1. Coaxial cable is not included, you need to purchase Coaxial cable separately.
2. Connect one end of the coaxial cable to the coaxial output of your TV or Satellite/Cable box.
3. Connect the other end of the coaxial cable to coaxial input on the base.

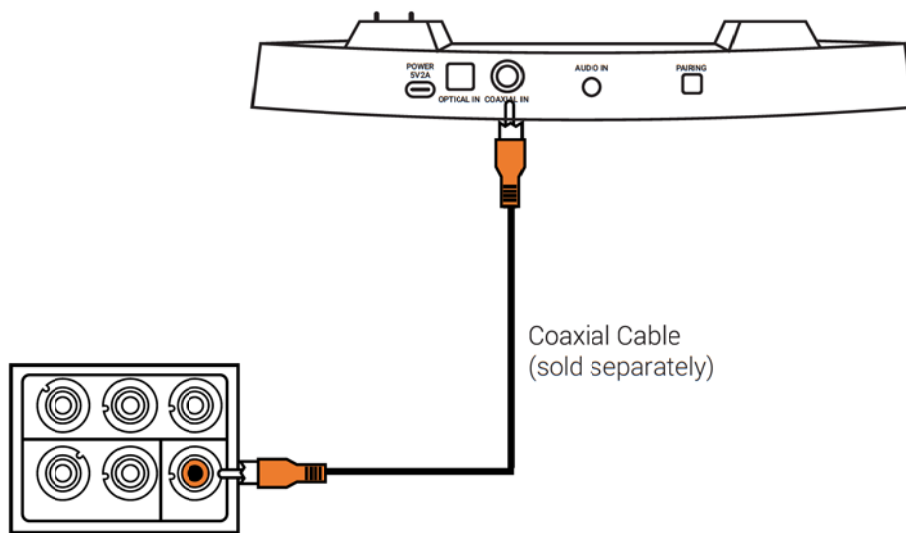

Orange connector on Back of your TV or Satellite/Cable Box

## C1 Analog audio RCA connection:

1. Locate the "RCA to 3.5mm adapter" (see picture below) and the "3.5mm male to male cable" that are included in the box.
2. Connect one end of the "3.5mm male to male cable" to the "RCA to 3.5mm adapter" (see picture below).
3. Connect the Red and White RCA connectors to RCA analog audio output on the back of your TV or Satellite/Cable box.
4. Connect the 3.5mm end of the cable to the Audio In on the base as shown below.

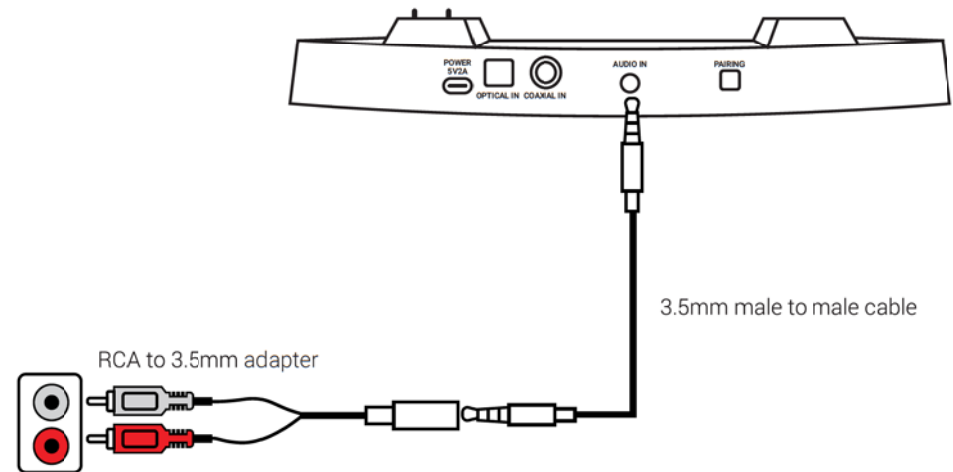

RCA audio out on Back of your TV or Satellite/Cable Box

## C2 Analog audio RCA connection using RCA splitters:

1. If the RCA analog audio output on the back of your TV is taken up by another device, you'll need to purchase **two** "RCA male to female splitters". These are not included in the package.



RCA male to female splitters  
(two are required)

2. Inside the box, you'll find an "RCA to 3.5mm adapter" and "3.5mm male to male cable" as shown below.



RCA to 3.5mm adapter



Analog Audio Cord (3.5mm male to male)

3. Remove the existing RCA connection and take the "RCA male to female splitters" and plug them into the RCA analog audio output on the back of your TV or Satellite/Cable box as shown below.

4. Now take the "RCA to 3.5mm adapter" from the box and connect it to the "RCA male to female splitters" as shown below.
5. Take the "3.5mm male to male cable" and connect one end of it to the "RCA to 3.5mm adapter".
6. Finally, connect the other end of the 3.5mm cable into the Audio IN on the base.
7. Reconnect your other device to the unused ports on the "RCA male to female splitters" as shown below

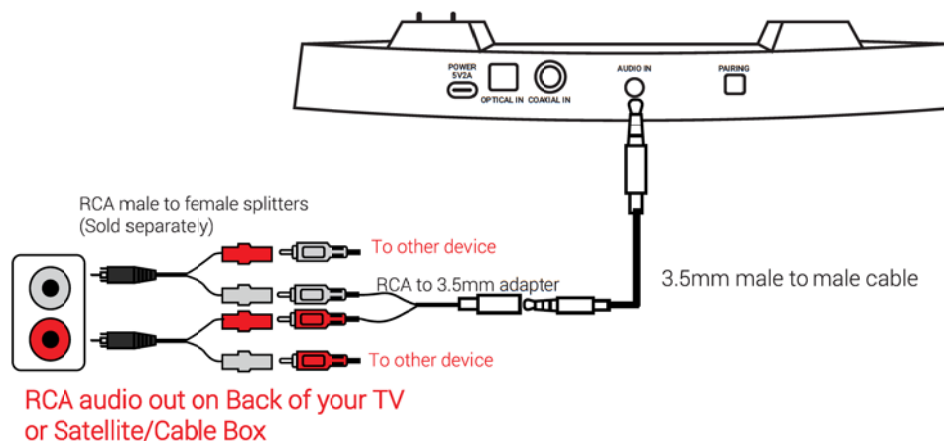



## D 3.5mm audio connection

1. Locate the 3.5mm male to male cable that is included in the box.
2. Connect one end of the 3.5mm male to male cable to the auxiliary output on the back of your TV or Satellite/Cable box.
3. Connect the other end of the 3.5mm audio cable to the Audio IN on the base as shown below.

**Note:** Using the 3.5mm connection on your TV may mute the TV speaker. Please refer to you TV audio settings to enable TV speaker while using the 3.5mm Auxiliary input on your TV.

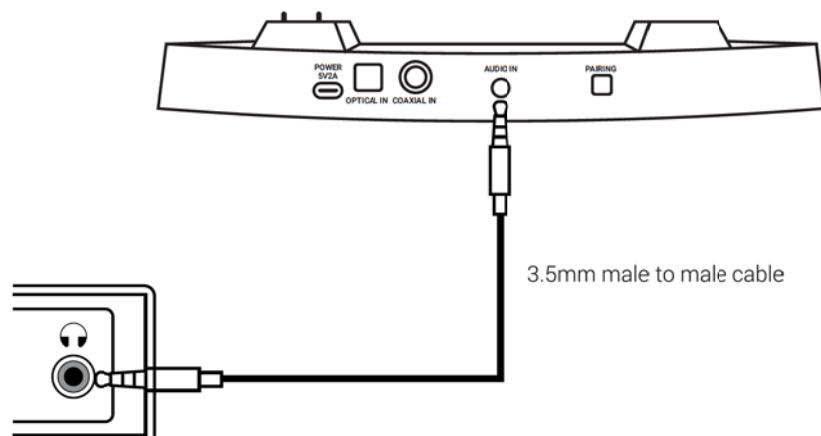

Auxiliary audio out on Back of your TV or audio source

## 04 Power on the base and the audio source:

Connect the TV Speaker base to power outlet using the included power adapter as shown below and ensure that your audio source (i.e TV or Satellite/Cable box) are turned on.

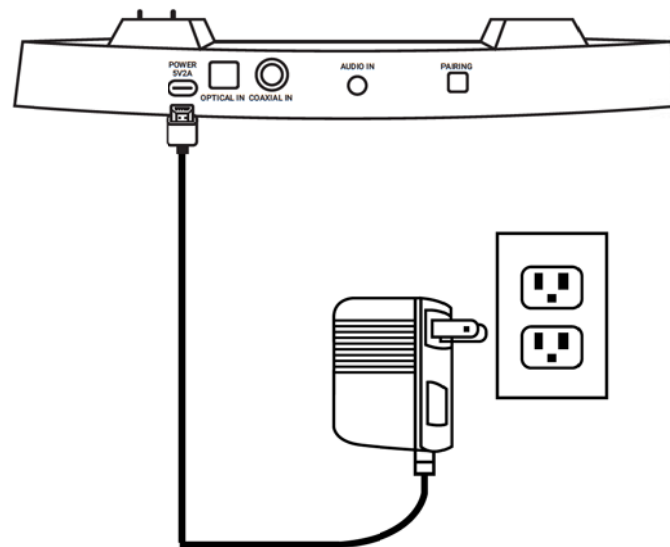

## CHARGING:

Place the Speaker on the Base as shown below for 4+ hours before first use. During charging, the low battery/charge green LED indicator blinks. When the Speaker is fully charged, the green LED will stop blinking and stay steadily lit. A fully charged battery will provide you about 8 hours of listening time at moderate volume.

When the Speaker is not in use or when the low battery indicator blinks, place the Speaker back on the Base for recharging.

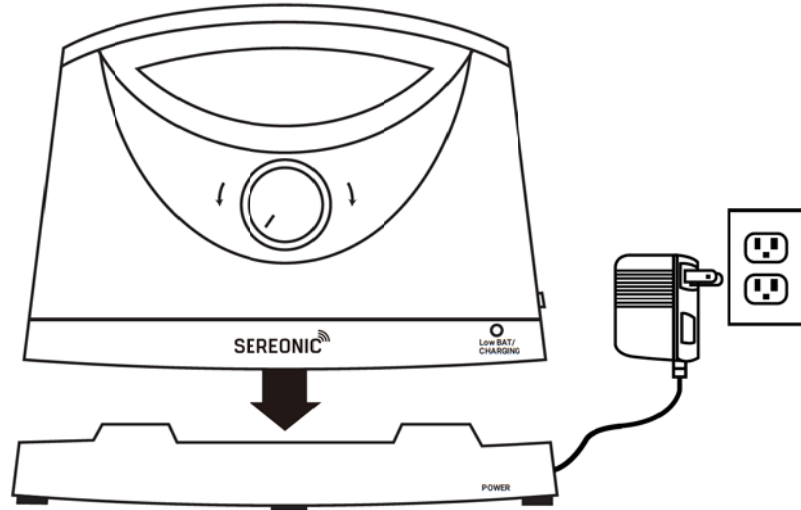

## CHARGING YOUR SPEAKER WITHOUT THE BASE:

Purchase an additional AC adapter (available from Serene Innovations) and plug it into the Speaker as shown below. This way, you can place and keep the Speaker at the same location without the need to return it to the Base for recharging.

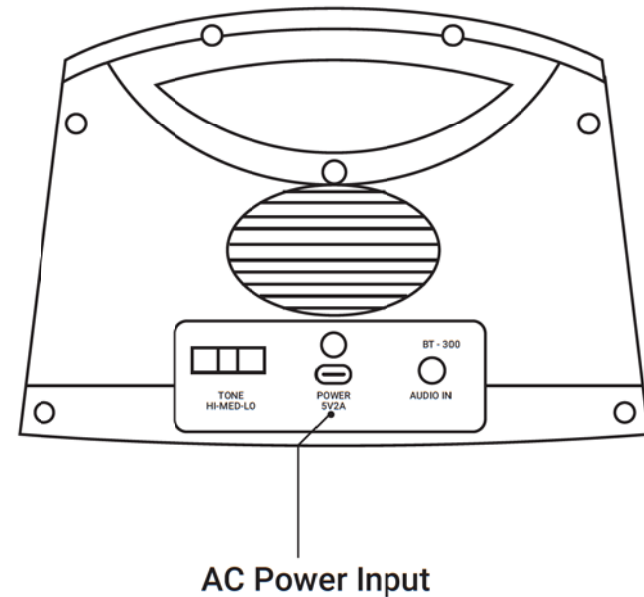

## OPERATIONS:

1. Rotate the knob clockwise to turn Speaker ON and to adjust volume, the blue ring light will turn on. Rotate the knob counter clockwise to turn speaker OFF.

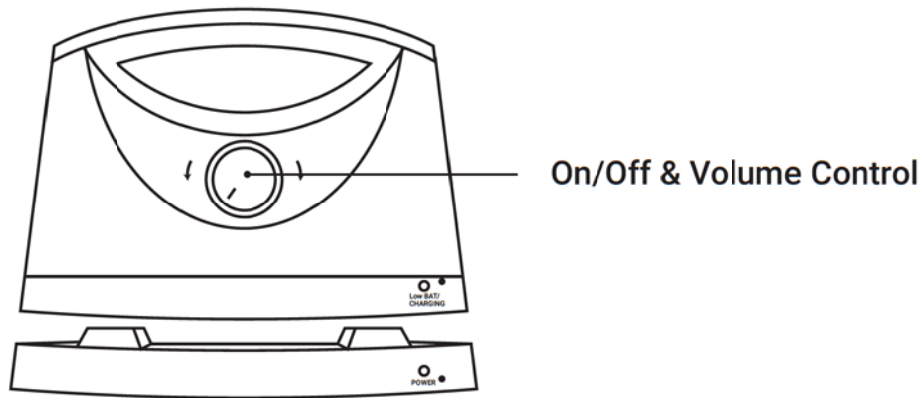

2. The wireless speaker volume control works independently from your TV speakers, you can turn down your TV speakers to low or off.

3. Set the Tone Control Hi, Med, or Low on the back of the Speaker to a position that enables you to hear and best understand the audio dialog.

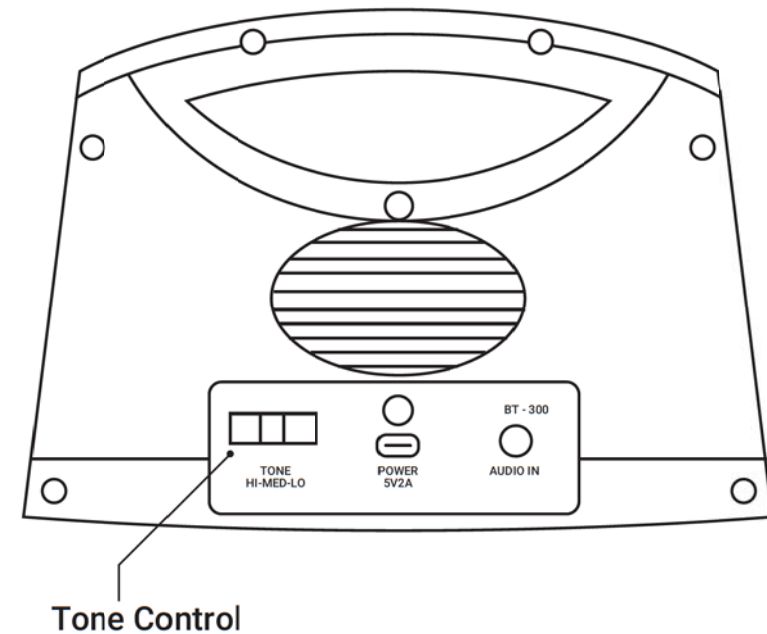

## PAIRING:

Your SEREONIC TV-SoundBox has already been paired and ready to go right out of the box. In case that a re-pairing between the Speaker and the Base is needed or you need to pair additional Speakers please follow the steps described below.

## SPEAKERS PAIRING PROCEDURE:

You can add up to 10 Speaker to work with your Base. If you need to re-pair your existing Speaker or pair additional Speaker to the Base, please follow the steps below.

Make sure the Speaker is fully charged.

Make sure the Base is properly connected and the green LED on the base is NOT blinking and is steadily lit.

### To pair a Speaker to the Base

1. Turn on the Speaker.

2. Press and hold the PAIRING button on the side of the Speaker until the volume knob indicator starts blinking.

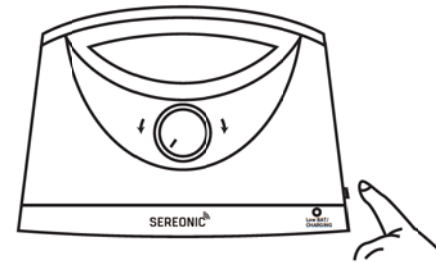

3. Press and hold the PAIRING button on the back of the Base until the green LED starts blinking.

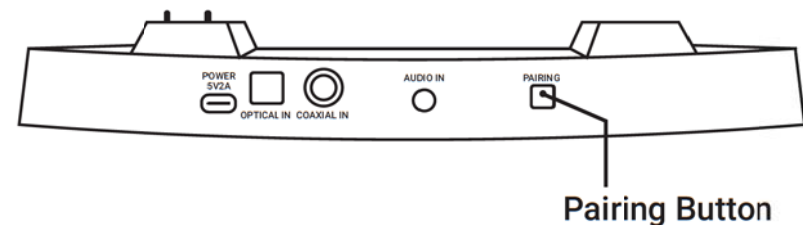

4. As soon as pairing is successful the audio sounds will start playing.
5. Repeat the steps again if pairing was not successful.

**Note:** If you are pairing multiple speaker, you can only pair one speaker at a time.

---

## USING A HEADPHONE:

Plug in your headphone to the Headphone jack on the side of the Speaker as shown below. No sound will be emitted from the Speaker while the Headphone jack is plugged in. Adjust the headphone volume by rotating the Volume knob on the Speaker.

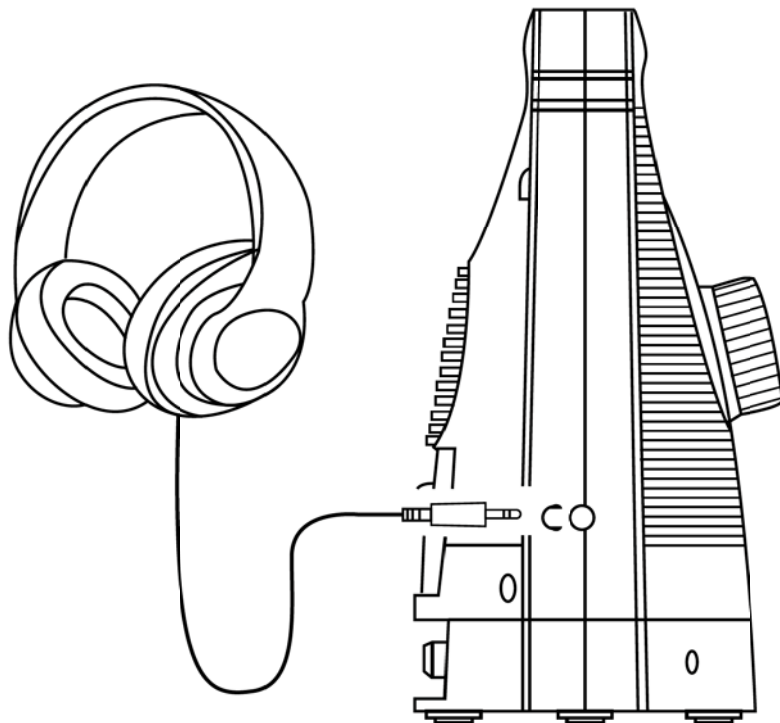

## TROUBLESHOOTING:

### No sound from the Speaker:

A blinking green LED on the base indicates that audio is NOT detected by the base. Please check all connections to ensure that all the cords are firmly connected at the back of the base and TV Also, confirm that the Speaker is not more than 100 feet away from the base.

### There is sound from the TV, but no sound from the Speaker.

Check your TV speaker setting by going into the TV Menu, using your TV remote and ensuring the TV is sending audio signals to external speaker

### The low Battery/Charging indicator keep blinking on the speaker:

This indicates that the battery is low and needs to be placed on the base for recharging. When fully charged, the blinking will stop. If the blinking does not stop, check to make sure the Speaker is firmly connected and properly seated on to the Base.

## CLEANING AND MAINTENANCE:

Unplug the AC adapter from the wall. Use dry, soft cloth to clean and dust the outside surfaces and the charging contacts. Do not immerse the Speaker or the Base in water.

## OPTIONAL ACCESSORIES:

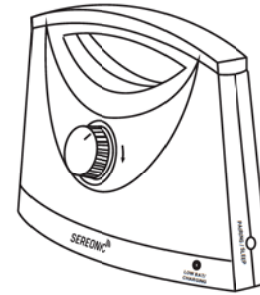

### **BT-200RX**

Extra receiver for added Convenience and mobility

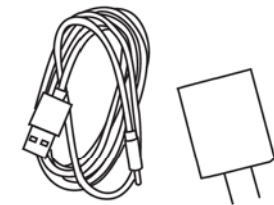

### **BT-200 APTR**

Extra adapter to charge your Speaker without the base.

## SPECIFICATIONS:

RF Transmission	2.4GHz Frequency
Speakers	2 X 5W Class D
Frequency Response	20Hz -20KHz
Battery	1 X 18650
Charge Time	4+ hours
Receiver Range	up to 100 ft (30m) open field
AC Adapter	Input 100-240VAC/50-60 Hz Output 5VDC / 2000 mA
Listening Time	about 8 hours @ 50% level
Dimensions	9"X7"x3.25" (24X11X8 cm)
Weight	about 1.7 lbs (800g)

Specifications are subject to change without notice.

## WARRANTY/SERVICE INFORMATION:

Your SEREONIC TV-SoundBox comes with one-year limited warranty. We warrant during the warranty period from the date of purchase to the original consumer that the SEREONIC TV-SoundBox will be free from defects in materials and workmanship under intended home use. If the SEREONIC TV-SoundBox fails to function properly within one year of original purchase due to defects in material or workmanship, return the unit (freight prepaid) with proof of purchase (sales receipt or packing slip, no exceptions) to Serene Innovations.

Serene Innovations will either repair or replace the unit and return it to you at no cost. There will be a nominal additional shipping charges if it is shipped to outside the 48 Continental U.S.A.

This warranty does not apply to any product that has been accidentally damaged due to abuse, misuse, negligent use or electrical frequency or voltage other than marked on product and/or described in this manual. Defects or errors caused by unauthorized alterations, repairs and/or tampering are also not covered by this warranty.

Any authorized returned product must be accompanied with proof of purchase and a brief description of the problem. For out of warranty repair and service, please contact our Customer Care Department for further details.

---

### **Incidental of Consequential Damages:**

---

Neither Serene Innovations nor the retailer, dealer or selling distributor has the responsibility for any incidental or consequential damages, including, without limitation, commercial loss of profit or for any incidental expenses, loss of time or inconvenience. Some states do not allow exclusion or limitation of incidental or consequential damage, so the above limitation or exclusion may not apply to you.

This warranty does not apply to any product that has been accidentally damaged, abused, misused or neglected, used on electrical frequency or voltage other than marked on product and/or described in the manual. Defects or errors caused by unauthorized alterations, repairs and/or tampering, are also not covered by this warranty.

This Warranty gives you specific legal rights and you may also have other legal rights that vary from state to state.

If a defect covered by this warranty should occur, promptly contact a Customer Care Representative by phone, or log onto [www.sereneinnovations.com](http://www.sereneinnovations.com) to obtain a Return Merchandise Authorization Number (RMA) and shipping instructions before shipping the product to Serene Innovations. Any shipment without an RMA number, will not be accepted and will be returned to you at your expense. Any authorized returned product must be accompanied by a proof of purchase and a brief explanation of the problem.

For out-of-warranty repair and service, please contact our Customer Care Department for directions.

### **FCC Rules Information**

#### **Part 15 of FCC Rules Information**

---

This device complies with Part 15 of the FCC rules. Operation is subject to the following two conditions: (1) this device may not cause harmful interference, and (2) this device must accept any interference received, including interference that may cause undesired operation. This equipment has been tested and found to comply with the limits of a Class B digital device, pursuant to Part 15 of FCC rules. These limits are designed to provide reasonable protection against harmful interference in residential installation.

This equipment generates, uses, and can radiate radio frequency energy and, if not installed and used in accordance with the instructions, may cause harmful interference to radio communications. However, there is no guarantee that interference will not occur in a particular installation. If this equipment does cause harmful interference to radio or television reception, which can be determined by turning the equipment off and on, the user is encouraged to try correcting the interference by one or more of the following measures:

01. Reorient the receiving antenna.

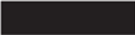

- 
- 
02. Increase the separation between the equipment and receiver.
  03. Connect the equipment into an outlet on a circuit different from that to which the receiver is connected.
  04. Consult the dealer or an experienced radio/TV technician for help.

Changes or modification not expressly approved by the party responsible for compliance could void your authority to operate the equipment.

This device should be installed and operated with minimum distance 0mm between the radiator&your body.

#### IC warning

This device complies with Industry Canada licence-exempt RSS standard(s). Operation is subject to the following two conditions:

(1) This device may not cause interference and (2) this device must accept any interference, including interference that may cause undesired operation of the device.

Le présent appareil est conforme aux CNR d'Industrie Canada applicables aux appareils radio exempts de licence. L'exploitation est autorisée aux deux conditions suivantes :

- (1) l'appareil ne doit pas produire de brouillage, et
- (2) l'utilisateur de l'appareil doit accepter tout brouillage ra

Under Industry Canada regulations, this radio transmitter may only operate using an antenna of a type and maximum (or lesser) gain approved for the transmitter by Industry Canada. To reduce potential radio interference to other users, the antenna type and its gain should be so chosen that the equivalent isotropically radiated power (e.i.r.p.) is not more than that necessary for successful communication.

Conformément à la réglementation d'Industrie Canada, le présent émetteur radio peut fonctionner avec une antenne d'un type et d'un gain maximal (ou inférieur) approuvé pour l'émetteur par Industrie Canada. Dans le but de réduire les risques de brouillage radioélectrique à l'intention des autres utilisateurs, il faut choisir le type d'antenne et son gain de sorte que la puissance isotrope rayonnée équivalente (p.i.r.e.) ne dépasse pas l'intensité nécessaire à l'établissement d'une communication satisfaisante.

This radio transmitter (identify the device by certification number, or model number if Category II) has been approved by Industry Canada to operate with the antenna types listed below with the maximum permissible gain and required antenna impedance for each antenna type indicated. Antenna types not included in this list, having a gain greater than the maximum gain indicated for that type, are strictly prohibited for use with this device.

Le présent émetteur radio (identifier le dispositif par son numéro de certification ou son numéro de modèle s'il fait partie du matériel de catégorie I) a été approuvé par Industrie Canada pour fonctionner avec les types d'antenne énumérés ci-dessous et ayant un gain admissible maximal et l'impédance requise pour chaque type d'antenne. Les types d'antenne non inclus dans cette liste, ou dont le gain est supérieur au gain maximal indiqué, sont strictement interdits pour l'exploitation de l'émetteur.

La distance minimale généralement utilisée est d'au moins 0 mm.



**Serene Group, Inc**



3401 E University Drive, Denton, TX 76208



Toll Free: 866-376-9271, Fax: 562-483-2087



Website: [www.sereneinnovations.com](http://www.sereneinnovations.com)



Email: [CS@Sereneinnovations.com](mailto:CS@Sereneinnovations.com)