

User Guide

PR-OCTO: telemetry device for coolers remote control and tracking



Content	1. Introduction.....	2
	2. Layout	2
	3. Compatibility.....	4
	4. Connections and wires	4
	5. Choosing the position in the cooler	5
	6. Installation in the coolers	7
	7. Prosa mandatory settings.....	8
	8. Technical specification.....	8
	9. Dimensions	9
	10. Warnings.....	10

1. Introduction

The PR-OCTO is one of the telemetry device that Danfoss uses in order to create an Internet Of Things. The PR-OCTO is able to communicate a specified set of alarms raised on the cooler. To this aim, the PR-OCTO has to work in conjunction with the electronic thermostat of the cooler, which controls the compressor of the cooler. The PR-OCTO contains a modem and uses a Machine to Machine (M2M) SIM in order to communicate with the Danfoss Infrastructure through the mobile network.

It contains also a Wi-Fi module used for hot spot discovery (Wi-Fi scanning). The mobile network and Wi-Fi hot spot are also exploited by the PR-OCTO in order to compute a trilateration. When the cooler is installed in a position defined by the owner of the equipment, the PR-OCTO has to learn that the visible mobile antennas and the resulting computed position correspond to the "authorized position". If the cooler is moved in a new position, once it is switched-on the PR-OCTO will spend some hours to compute the new position. If such a new position is computed to be at least one kilometer far from the authorized position, the PR-OCTO sends a warning to the Danfoss main system.

2. Layout

The diagram illustrates the layout of the OCTO device. It has only two connectors. The COMM connector allows the communication with the electronic thermostat, while the power supply connector is a two-pin fast-on connector to power the device at 100 – 240 V AC, 50/60 Hz.

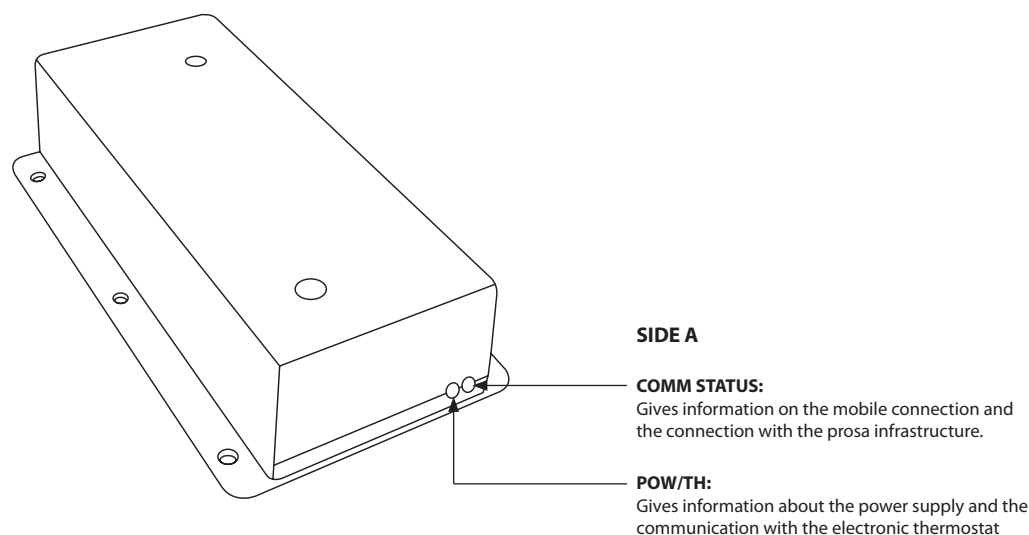

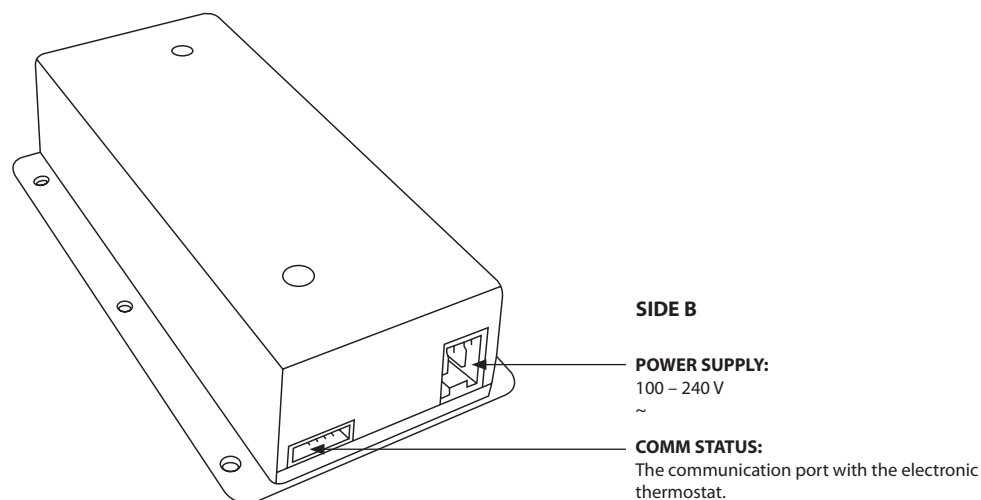

On SIDE A the OCTO for SLOT 2020 device presents two LEDs. The red one, on the right, gives information about the power supply and about the communication with the electronic thermostat, while the green one, on the left, gives information about the GPRS network and about the communication with the Danfoss infrastructure. The behavior of the LEDs is the following:

- RED LED OFF : The device is not correctly powered.
- RED LED blinking : The device is powered and the communication with the electronic thermostat is not established yet.
- RED LED ON : The device is powered and the communication with the electronic thermostat is correctly established.
- RED LED fast blinking : The device is powered while the communication with the electronic thermostat has been interrupted.

3. Compatibility

The device PR-OCTO gives the possibility to perform the block command and to grasp diagnostic information only in conjunction with an electronic thermostat. The current version of the PR-OCTO includes the compatibility with the Danfoss ERC 111 and 112 thermostats. For other models and brands please contact your commercial contact.

4. Connections and wires

The PR-OCTO requires two connections, one for the power supply, the other with the electronic thermostat.

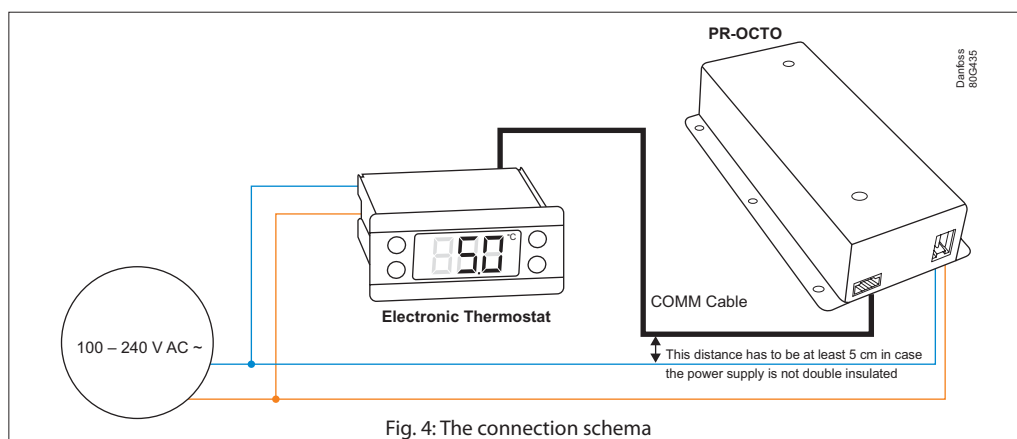

The power supply can be shared with the electronic thermostat: the PR-OCTO device does not require additional power adapter.

Note: All the cables have to be assembled by the Cooler Manufacturer following the instructions here below.

For the POWER SUPPLY connector of the OCTO, either two standard fast-on connectors or one connector with screw terminal can be used. Fig. 5 on the right, illustrates the Lumberg 3611 02 K1, an easy plug connector with lift clamp and protection against misplacing and fast assembling. Neither the standard fast-on connectors nor the easy plug connector are included in the OCTO package.

Note: If the power supply cable is not double insulated, it has to be physically separated from the COMM cable.

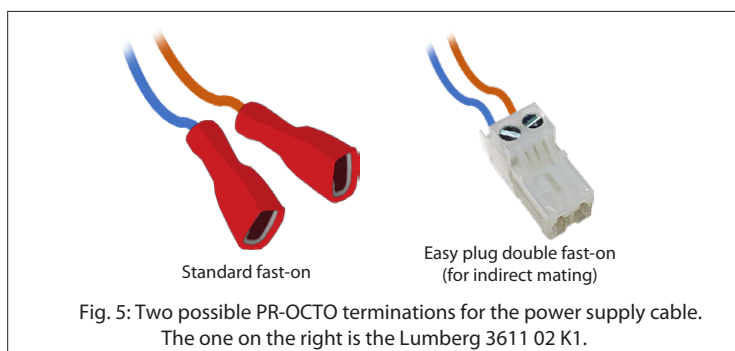

Concerning the COMM Cable (the communication cable between the PR-OCTO and the electronic thermostat) a specified cable has to be used depending on the specified thermostat. The COMM Cable could be either assembled by the cooler manufacturer or could be purchased from Prosa (please refer to "PR-OCTO: COMM Cable document").

Note: The COMM Cable for Danfoss thermostats have to be purchased from Danfoss.

5. Choosing the position in the cooler

The most important requirement for the PR-OCTO installation is to find the location inside the cooler where the mobile network signal is stronger and the device protected. The diagram below suggests the recommended positions for coolers:

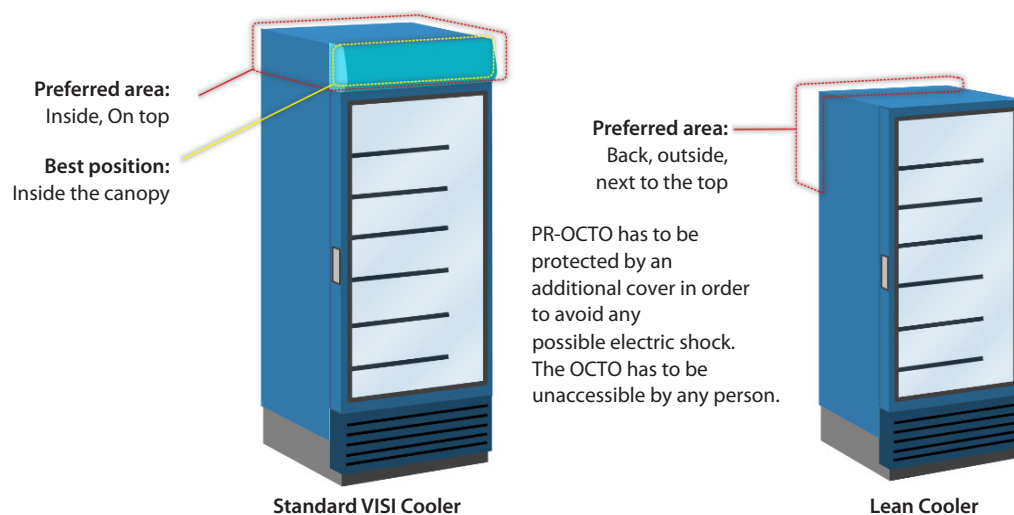

On standard visi coolers the best area is inside the canopy, since the canopy usually does not have metal plates that could decrease the mobile network signal. On lean cooler, since the lack of the canopy and the presence of metallic plates all around the cooler, the OCTO can only be installed outside the cooler, in the back area, next to the top.

Note: In case of installation on the back side of the cooler, the OCTO has to be protected with an additional box to protect people from electric shock.

Prosa has developed a specific PC software to help discovering the right position of the OCTO in the cooler. To exploit such software, follow these steps:

- Step 1: Download the VBCKSignalTester application from this URL: http://area.riservata.it/vbctksignaltester-1.0.0-setup-x86_32.exe
- Step 2: Install the VBCKSignalTester application in a Windows PC.
- Step 3: Connect the 'Test Cable' (see Fig. 6) to the PC and to the OCTO.
- Step 4: Power on the OCTO (see Section 4 for the power supply cable).
- Step 5: Run VBCKSignalTester and select the appropriate Serial COM port to which the 'Test Cable' is connected, as shown in Fig. 7a.
- Step 6: If the program shows "No Connection" as in Fig. 7b, try to change the COM port listed in the combo or check the cable connection.
- Step 7: When the system is finally connected to the device, it starts to display the Antenna Signal Level of the OCTO's internal antenna. Such level could be low (like in Fig. 7e), medium intensity (like in Fig. 7f) or almost the best signal level (like in Fig. 7d).
- Step 8: Try to change the position of the OCTO in the cooler in order to discover the highest possible Antenna Signal Level.
- Step 9: Power off the OCTO and disconnect the PC 'test cable'.



Fig. 6: PC Test Cable for monitoring the OCTO GPRS transmission signal level.



Fig. 7: VBCTKSignalTester application screenshots.

Once discovered the best position with respect to the Antenna Signal Level, it is possible to decide if it is the case to protect the Side B (the one with the connectors) of the OCTO. To this aim, it can be adopted the same approach that the cooler manufacturer uses to protect the connector side of the electronic thermostat, hence a piece of plastic with an appropriate shape can be used. If a piece of plastic is not available, a metallic plate can be used but the covered area of the OCTO has to be as small as possible (the limit should be 5 cm from the front of the OCTO, as illustrated in Fig. 8).

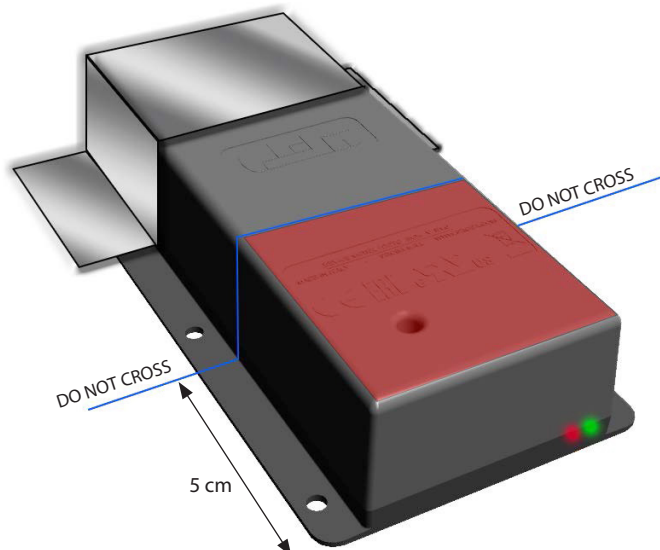

Fig 8: In case of metallic protection, do not cross the indicated line otherwise the signal of the internal antenna results corrupted.

6. Installation in the coolers

During the industrial production of the coolers, there should be a phase in which the electronic thermostat is installed. In the same phase, also the OCTO device has to be installed. The following pre-conditions have to be satisfied:

- Pre-condition 1: The installation position has to be determined during the analysis performed as described in Section 5.
- Pre-condition 2: One COMM CABLE for each cooler has been correctly assembled for the corresponding thermostat model with the appropriate length with respect to the position of both the OCTO and the electronic thermostat.
- Pre-condition 3: A power supply cable has been prepared using one of the connectors illustrated in Fig. 5.
- Pre-condition 4: A protection, if any, has been prepared, and in case of metallic protection it satisfies the constraint illustrated in Fig. 8.

For the installation, the following steps have to be performed:

- Step 1: While the cooler is off, put the OCTO unplugged inside the cooler in the appropriate position.
- Step 2: Connect the COMM cable to the thermostat and to the OCTO.
- Step 3: Connect the power supply cable to the OCTO while such cable is not powered, as illustrated in Fig. 4.
- Step 4: Install the protection, if any.
- Step 5: Power on the cooler (and consequently the OCTO). The red led of the OCTO starts blinking. Wait until the red led stops blinking. If it results always on, then the device is powered and the communication with the electronic thermostat is correctly established.
- Step 6: Wait until the green led remains always on.
- Step 7: In case of success in STEP 6, and only in such case, the cooler code and the OCTO code have to be associated. This association is illustrated in Fig. 9. Both the cooler serial number and the OCTO Device Code have to be read using a bar code reader and to be traced in a special document where the cooler model, the cooler serial number and the OCTO device code must be written.

Note: In case STEP 7 is not properly executed, the future owner of the cooler will not recognize the cooler through the Prosa infrastructure.



9. Dimensions

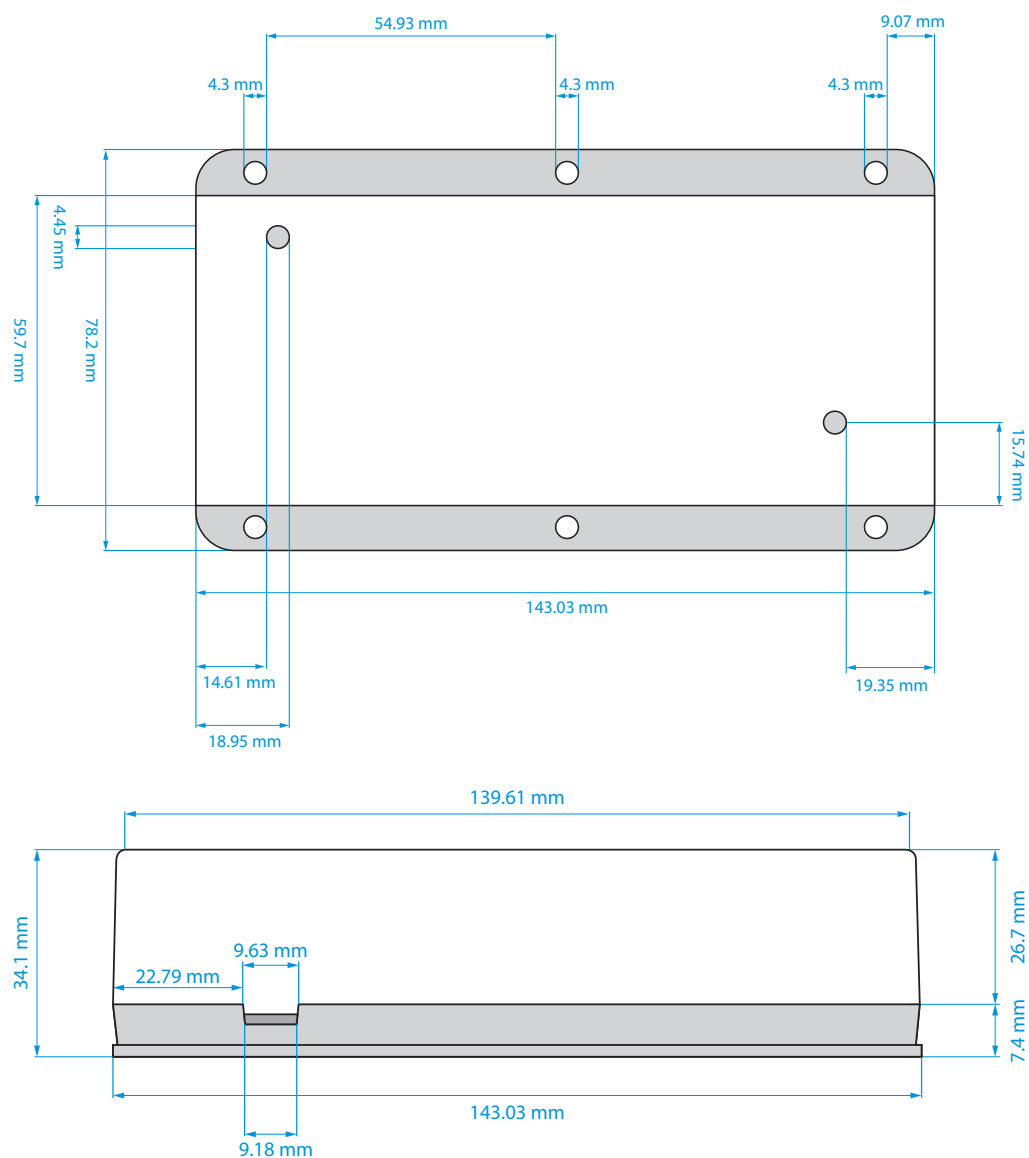

Fig 10. Size of the OCTO plastic box

10. Warnings



The installation of the OCTO has to be performed only and exclusively by qualified and skilled technicians.



The installation of the OCTO should be performed while the cooler is switched-off.



Inside the device there is a GPRS antenna. For this reason, while the OCTO is working it must be at the minimum distance of 9.5 cm (4") from the people. The installation must be done to ensure this distance.



The OCTO has to be installed in a protected position. The OCTO has to be embedded in the cooler and not accessible. In case of installation on the back side of the cooler, the OCTO has to be protected with an additional box to protect people from electric shock.



If the power supply cable of the OCTO is not double insulated, it has to be physically separated from the COMM cable (the communication cable with the thermostat).



The OCTO input power supply is protected by over-currents by the F002 device, with this characteristics: delayed fuse 250 V 400 mA.



Any document related to the conformity declaration of the OCTO can be downloaded from www.prosa.com.



This equipment is not suitable for use in locations where children are likely to be present.

Cet équipement ne convient pas à une utilisation dans des lieux où des enfants sont susceptibles d'être présents.