

Prüfbericht-Nr.: <i>Test report no.:</i>	ULR-TC568822300000092F IN22C7ZR 001	Auftrags-Nr.: <i>Order no.:</i>	146711779 010	Seite 1 von 53 Page 1 of 53
Kunden-Referenz-Nr.: <i>Client reference no.:</i>	2009322	Auftragsdatum: <i>Order date:</i>	2022.08.24	
Auftraggeber: <i>Client:</i>	ABMRC, LLC 860 Blue Gentian Road Suite 200 Eagan, MN, 55121-1567			
Prüfgegenstand: <i>Test item:</i>	BiWave Clear	Serien-Nr.: Serial No.:	CLR-PRT-019	
Bezeichnung: <i>Identification.:</i>	PRTN-1463077491-181			
Auftrags-Inhalt: <i>Order content:</i>	Testing and issue of Test report with Grant Certificate			
Prüfgrundlage: <i>Test specification:</i>	FCC Part 15 Subpart C 15.247, 15.207, 15.205 & 15.209			
Wareneingangsdatum: <i>Date of sample receipt:</i>	2022.08.24			
Prüfmuster-Nr <i>Test sample no</i>	A003324163-001 A003324163-002			
Prüfzeitraum: <i>Testing period:</i>	2022.08.24 - 2022.09.13			
Ort der Prüfung: <i>Place of testing:</i>	Wireless laboratory, Bangalore			
Prüflaboratorium: <i>Testing laboratory:</i>	TÜV Rheinland (India) Pvt.Ltd., 27/B, 2nd Cross, Electronic City Phase1 Bangalore -560 100, India FCC Test site registration number: 496599 ISED Test site registration number: 3466E-1			
Prüfergebnis*: <i>Test result*:</i>	Pass			
geprüft von: <i>tested by:</i>	Yogesh V Engineer		genehmigt von: <i>authorized by:</i>	Madhu K.N Senior Engineer
Datum: <i>Date:</i>	2022.08.24		Ausstellatum: <i>Issue date:</i>	2022.12.19
Sonstiges / Other:	FCC ID: 2ATX9-BK181			
Zustand des Prüfgegenstandes bei Anlieferung: <i>Condition of the test item at delivery:</i>	Prüfmuster vollständig und unbeschädigt Test item complete and undamaged			
* Legende:	1 = sehr gut P(ass) = entspricht o.g. Prüfgrundlage(n)	2 = gut F(ail) = entspricht nicht o.g. Prüfgrundlage(n)	3 = befriedigend N/A = nicht anwendbar	4 = ausreichend N/T = nicht
* Legend:	1 = very good P(ass) = passed a.m. test specification(s)	2 = good F(ail) = failed a.m. test specification(s)	3 = satisfactory N/A = not applicable	4 = sufficient N/T = not
<p>Dieser Prüfbericht bezieht sich nur auf das o.g. Prüfmuster und darf ohne Genehmigung der Prüfstelle nicht auszugsweise vervielfältigt werden. Dieser Bericht berechtigt nicht zur Verwendung eines Prüfzeichens. <i>This test report only relates to the a. m. test sample. Without permission of the test center this test report is not permitted to be duplicated in extracts. This test report does not entitle to carry any test mark.</i></p>				



Prüfbericht - Nr.:
Test Report No.:

ULR-TC568822300000092F

Seite 2 von 53
Page 2 of 53

TEST SUMMARY

Test Item	Applicable Standard	Result
	FCC	
Maximum conducted (average) output power	FCC 15.247(b)(3)	Pass
Maximum Power Spectral Density	FCC 15.247(e)	*N/T
DTS Bandwidth	FCC 15.247(a)(2)	*N/T
Emissions in non-restricted frequency bands	FCC 15.247(d)	*N/T
Spurious Radiated Emissions and Restricted Bands of Operation	FCC 15.209 / FCC 15.205	Pass
Conducted Emissions on a.c Power Lines	FCC 15.207	Pass

Note:

*N/T: Not tested – These test cases are not tested, the product uses certified RF module **WiFi+BT Combo Module WL1831MOD**, with **FCC ID: Z64-WL18SBMOD & IC : WL1831MOD**.

Product Category: Electronics Testing
Test Discipline: EMC Test Facility

Prüfbericht - Nr.:
Test Report No.:

ULR-TC568822300000092F

Seite 3 von 53
Page 3 of 53

REVISION HISTORY OF THIS REPORT

Report Number	Version	Description	Issue date
ULR-TC568822300000092F	01	Initial issue of report	2022.12.19

Table of Contents

1	GENERAL REMARKS	5
1.1	Attachments	5
2	TEST SITES	6
2.1	Testing Facilities.....	6
2.2	List of Test and Measurement Instruments.....	6
3	GENERAL PRODUCT INFORMATION.....	8
3.1	Product Function and Intended Use.....	8
3.2	Measurement Uncertainty:	9
4	TEST SET-UP AND OPERATION MODE	10
4.1	Principle of Configuration Selection	10
4.2	Test Operation and Test Software	10
4.3	Special Accessories and Auxiliary Equipment	10
4.4	Simultaneous Transmission	10
4.5	Countermeasures to achieve EMC Compliance	10
4.6	List of frequencies	11
4.7	Report references.....	12
5	Operational Description	13
6	TEST METHODOLOGY	14
6.1	Conducted Spurious Emission Test on AC Power Line.....	14
6.1.1	Test Setup Configuration	14
6.2	Radiated Emission Test	15
6.2.1	Test Setup Configuration	15
7	TEST RESULTS FOR Wi-Fi.....	17
7.1	Maximum Average Conducted Output Power.....	17
7.2	Spurious Radiated Emissions & Restricted Bands of Operation	19
8	TEST RESULTS FOR BLUETOOTH LOW ENERGY	36
8.1	Maximum Peak Conducted Output Power	36
8.2	Spurious Radiated Emissions & Restricted Bands of Operation	38
9	Conducted Spurious Emission Test on AC Power Line	49
10	LIST OF TABLES.....	53

1 GENERAL REMARKS

1.1 Attachments

All attachments are part of this test report and are issued in separate document

- 1: TEST SETUP PHOTOS
- 2: EUT EXTERNAL PHOTOS
- 3: EUT INTERNAL PHOTOS
- 4: FCC LABEL AND LABEL LOCATION
- 5: BLOCK DIAGRAM
- 6: SPECIFICATION OF EUT
- 7: SCHEMATIC DIAGRAM
- 8: BILL OF MATERIAL
- 9: USER MANUAL
- 10: MAXIMUM PERMISSIBLE EXPOSURE INFORMATION

2 TEST SITES

2.1 Testing Facilities

- | | |
|--|---|
| <p>1. TÜV Rheinland (India) Pvt.Ltd.,
27/B, 2nd Cross,
ElectronicCityPhase1
Bangalore – 560 100,
India</p> | <p>2. TUV Rheinland (India) Pvt.Ltd.,
108 , Beside ISBR Business School,
Electronic city Phase I
Bangalore - 560 100.
India</p> |
|--|---|

Radiated Measurement site type :
Fully anechoic chamber (used for above 1 GHz
measurements)

Radiated Measurement site type :
Semi anechoic chamber (used for below 1 GHz
measurements)

2.2 List of Test and Measurement Instruments

Table 1: List of test and measurement instruments

Equipment	Manufacturer	Model Name	Serial Number	Firmware Versions	Calibration Due Date	Periodicity	Test Facility
Active loop antenna	Frankonia	LAX-10	LAX-10-800	-	31-01-2023	Yearly	Radiated Spurious Emission
Baloon and Biconical Antenna	Schwarzbeck Mess-Elektronik	VHBB-9124 / BBA-9106	1028	-	03-02-2023	Yearly	
Log - Periodical Antenna	Schwarzbeck Mess-Elektronik	VUSLP 9111B	9111B-111	-	04-02-2023	Yearly	
Horn Antenna	Frankonia	HAX-18	HAX18-802	-	20-05-2023	Yearly	
Semi Anechoic Chamber	Frankonia	-	-	-	-	-	
Fully Anechoic Chamber	Albatross	-	-	-	-	-	
EMI Receiver	Rohde & Schwarz	ESW 44	101732	4.73.SP5	04-08-2023	Yearly	
EMI Receiver	Rohde & Schwarz	ESW44	101773	1.72SP1	12-02-2023	Yearly	
Signal Analyser	Rohde & Schwarz	FSV7	101644	FW 3.40	25-01-2023	Yearly	Antenna-Port Conducted test
Spectrum Analyzer	Agilent	E4407B	US41192772	A.14.06	15-12-2022	Yearly	
Signal Analyser	Anritsu	MS2830 A	6261983953	-	14-09-2022	Yearly	
EMI Receiver	Rohde & Schwarz	ESR7	101133	3.48 SP3	22-07-2023	Yearly	Conducted AC Power line Test
Pulse Limiter	Rohde & Schwarz	ESH3-Z2	100811	-	12-07-2023	Yearly	
LISN	Rohde & Schwarz	ENV216	100022	-	07-10-2022	Yearly	

Prüfbericht - Nr.:
Test Report No.:

ULR-TC568822300000092F

Seite 7 von 53
Page 7 of 53

Table 2: Instrument application Software versions

SL. No.	Test Type	Application software	Version
1	Radiated spurious emission measurement in 10mtr-SAC	BAT EMC	3.20.0.17
2	Radiated spurious emission measurement in 3mtr-FAC	EMC 32	10.60.20

3 GENERAL PRODUCT INFORMATION

3.1 Product Function and Intended Use

BiWaze Clear System will enhance airway clearance by providing a therapy that will improve lung mechanics and gas exchange to help prevent or treat atelectasis. It will provide lung expansion therapy by delivering continuous positive expiratory pressure. It will also provide high-frequency oscillations to break up the mucus and help move the mucus up the mucociliary escalator. During both treatments, the device can deliver nebulizer medication to keep the airways moist. The nebulizer can also be run alone to provide medication deep into the lung's airways.

Device Intended Use:

BiWaze Clear System is intended for the mobilization of secretions, lung expansion therapy, the treatment and prevention of pulmonary atelectasis and has the ability to provide supplemental oxygen when used with an oxygen supply.

Table 3: Ratings and System Details as declared by Client*

Radio Protocol	Wi-Fi	BLE
Operating Frequency Range	2412MHz to 2462MHz	2402MHz to 2480MHz
No. of Channels	11 (Refer Table 5)	40 (Refer Table 6)
Channel Spacing	5MHz	2MHz
Maximum Measured Power(dBm)	14.70dBm @ 2412MHz 802.11b	5.87 dBm @ 1Mbps
Modulation	802.11b: DSSS, 802.11g/n: OFDM, 802.11ax: OFDMA	GFSK
Number of antennas	One	One
Antenna Gain	2 dBi (Peak Gain)	2 dBi (Peak gain)
Antenna Type	SMD Chip Antenna	SMD Chip Antenna
Supply Voltage to Product	110V AC 60 Hz Power Supply	
Environmental conditions	Storage	5°C to +60°C Relative Humidity 10% < to <90%
	Operating	5°C to +40°C Relative Humidity 15%< to <90%
EUT Dimension(L x W x H) in mm	275 mm x 240 mm x 95 mm	

***Disclaimer:** The information/data is supplied by the client and the same is considered to arrive at the final value. Any changes made apart from the specified specification, can directly impact on the tests results. Refer the products user manual for more details.

3.2 Measurement Uncertainty:

Reported uncertainties represent expanded uncertainties expressed at approximately the 95% confidence level using a coverage factor of $k = 2$

Table 4: Measurement Uncertainty

Parameter	Uncertainty
Occupied Channel Bandwidth	±5 %
RF output power, conducted	±1.5 dB
Power Spectral Density, conducted	±3 dB
Unwanted Emissions, conducted	±3 dB
All emissions, radiated	±6 dB
Temperature	±3 °C
Supply Voltages	±3 %
Time	±5 %

Note: The Listed Measurement Uncertainties are the worst-case uncertainty, for the respective test cases. Above Table is for reporting purpose only and not used in determining Final Pass/Fail verdict.

4 TEST SET-UP AND OPERATION MODE

4.1 Principle of Configuration Selection

Transmission was enabled with highest possible duty cycle on low, mid and high channel.

4.2 Test Operation and Test Software

PCBA Versions:

- 1) PCBA_CLEAR_MCB (PRTN-247461987-33) - Version 3.2
- 2) PMB ASSEMBLED BOARD (PRTN-2037351818-229) - Version 3.5
- 3) UIB ASSEMBLED BOARD(PRTN-2037351818-247) - Version 3.1
- 4) PCBA_SNB(PRTN-247461987-2) - Version 1.2
- 5) SYSTEM ON SWITCH ASSEMBLED BOARD(PRTN-2037351818-251) - Version 1.3
- 6) PCBA_AerogenConBoard(PRTN-247461987-28) - Version 1.0

Firmware Versions:

1. MCB Blower Driver Firmware Clear (PRTN-247461987-41)- Version 1.2.0
2. MCB Stepper Driver Firmware Clear (PRTN-247461987-40)- Version 1.2.0
3. MCB Main Microcontroller Firmware Clear (PRTN-247461987-42)- Version 1.2.0
4. MCBBootLoader Clear (PRTN-247461987-43)- Version 1.2.0

UI Software Version: Version 1.1.0

WiFi & BT/BLE module firmware:

BT/BLE module Firmware version (TlInit_11.8.32.bts) : 11.8.32
Wifi module Firmware version (wl18xx-fw-4.bin) : 8.9.0.0.76

EUT Configuration:

Power Supply: 1 phase, 110VAC/60Hz (Battery charging mode).
Set Therapy Mode: AUTO Mode
Cycle configuration:
Inhale Pressure: 70 cmH₂O with Nebulizer function
Accessories : Breathing circuit, Nebulizer and SpO₂ connected
(SpO₂ is optional accessories)
Oscillation: High
Cycle Duration: 30mins
Number of cycles: 7

4.3 Special Accessories and Auxiliary Equipment

- Device Accessories: Breathing Circuit, Handset, Nebulizer and SpO₂ sensor

4.4 Simultaneous Transmission

This product supports Simultaneous transmission

4.5 Countermeasures to achieve EMC Compliance

- No

4.6 List of frequencies

Frequency Band (MHz)	Channel No.	Channel Frequency (MHz)
2412 – 2462	1	2412
	2	2417
	3	2422
	4	2427
	5	2432
	6	2437
	7	2442
	8	2447
	9	2452
	10	2457
	11	2462

Table 5: List of Wi-Fi center Frequencies

Channel used for Wi-Fi 2.4GHz testing

Protocol: WLAN 802.11b

Channel Low : 2412 MHz
Channel Mid : 2437 MHz
Channel High : 2462 MHz

Protocol: WLAN 802.11g

Channel Low : 2412 MHz
Channel Mid : 2437 MHz
Channel High : 2462 MHz

Protocol: WLAN 802.11n_20MHz

Channel Low : 2412 MHz
Channel Mid : 2437 MHz
Channel High : 2462 MHz

Frequency Band (GHz)	Channel No.	Frequency (MHz)
BLE (2.4-2.4835)	0	2402
	1	2404
	2	2406
	3	2408
	:	:
	:	:
	18	2438
	19	2440
	20	2442
	:	:
	:	:
	36	2474
	37	2476
	38	2478
	39	2480

Table 6: List of BLE Center frequencies

Channel used for BLE testing

Channel low : 2402MHz
Channel mid : 2440MHz
Channel High : 2480MHz

Note:

TUV Sample Identification number : A003324163-001 (Radiated sample) &
A003324163-002 (Conducted sample)

Prüfbericht - Nr.:
Test Report No.:

ULR-TC56882230000092F

Seite 12 von 53
Page 12 of 53

4.7 Report references

Note: Product **BiWaze Clear System** has multiple protocols. All the supported wireless protocols and their respective test results are issued in separate test reports, following table lists the report numbers.

Radio Protocol	Report Number
RF test report for Wi-Fi (2.4GHz) & BLE (2.4GHz) – (This report)	ULR-TC56882230000092F
RF test report for Bluetooth (2.4GHz)	ULR-TC56882230000093F

5 Operational Description

The mucociliary escalator and cough reflex maintain optimal function of the respiratory system by removing mucus and preventing airway obstruction. Healthy lungs produce and clear 10 to 100 mL of mucus by the centripetal movement of the mucociliary escalator and with the aid of transient increases in expiratory air flow.

There are many factors which interfere with the body's natural mechanisms to mobilize and evacuate mucus from the airways. Pulmonary disorders such as cystic fibrosis mucus and mucociliary clearance disorders such as primary ciliary dyskinesia reduce the efficacy of ciliary structure and function. Airway obstruction and damage to the lung result from recurring mucus retention, infection, and inflammatory changes. As a result, airway clearance techniques (ACTs) and devices that deliver airway clearance are used to aid in mucus mobilization and evacuation.

BiWaze Clear System

The BiWaze Clear System will enhance airway clearance by providing therapies that will improve lung mechanics and gas exchange to help prevent or treat atelectasis. Additionally, it will deliver positive expiratory pressure for lung expansion therapy. In addition, it will produce high-frequency oscillations to help break up mucus and move it up the mucociliary escalator. The device can deliver nebulized medication to keep the airways moist during treatments and assist in delivering nebulized medication deep into the lungs during oscillation and positive expiratory pressure phases. The nebulizer can also be used independently to deliver aerosol medication. BiWaze Clear delivers three therapies: Positive Expiratory Pressure (PEP), Oscillation (OSC), and nebulizer (NEB).

The BiWaze Clear System shall be prescription use only.

The BiWaze Clear System will enhance airway clearance by combining 3 respiratory therapies:

- **Positive Expiratory Pressure (PEP):** During PEP, the device delivers a programmed positive pressure which the patient exhales against which opens and expands the patient's airways. The nebulizer can also deliver medicated aerosol during PEP therapy to help move the medication into the lower airways.
- **Oscillation (OSC):** During OSC, the device oscillates the airways with pulses of positive pressure to thin and mobilize secretions from the lower airways to the upper airways so they can be coughed or suctioned out. The nebulizer can also deliver medicated aerosol during OSC therapy to help move the medication into the lower airways.
- **Nebulize (NEB):** During NEB, the device powers only the Aerogen solo vibrating mesh nebulizer. This therapy gives the patient a break from PEP or OSC therapy while the patient receives their nebulized medication.

6.2 Radiated Emission Test

The radiated emission measurement was performed according to the procedures in ANSI C63.10-2013. The equipment under test (EUT) was placed at the middle of the 80 cm high turntable for below 1 GHz & 1.5 m height for above 1 GHz measurement, and the EUT is 3 meters far from the measuring antenna. The turntable was rotated 360° for obtaining the maximum emission. The height of the measuring antennas was scanned between 1 m and 4 m, and the antenna rotated to repeat the measurements for both the horizontal and vertical antenna polarizations. Repeat the measurement steps until the maximum emissions were obtained. The measurement above 1000 MHz was performed by horn antenna, The measurement below 30 MHz was performed by loop antenna, Measurement from 30 MHz to 200 MHz was performed by Baloon and Biconical Antenna, and measurement from 200 MHz to 1 GHz was performed by Log-Periodic Antenna.

The EUT was rotated around the X-, Y-, and Z-Axis and the results from worst case axis are recorded

6.2.1 Test Setup Configuration

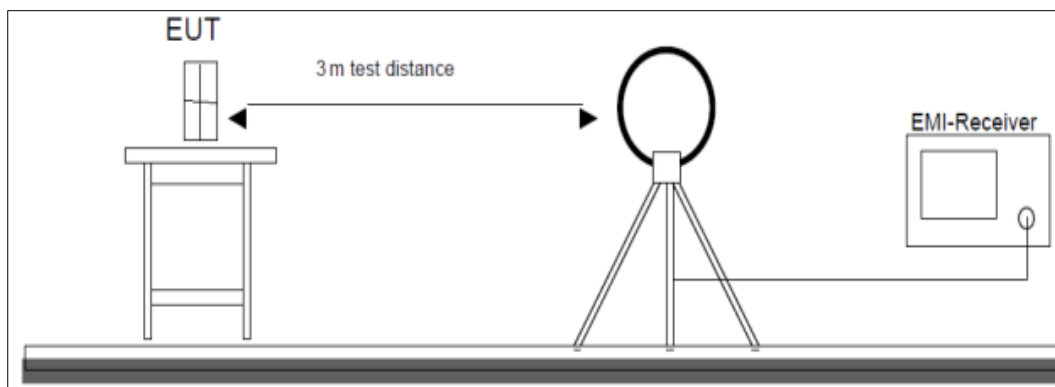

Figure 1: Frequency Range 9 kHz- 30 MHz

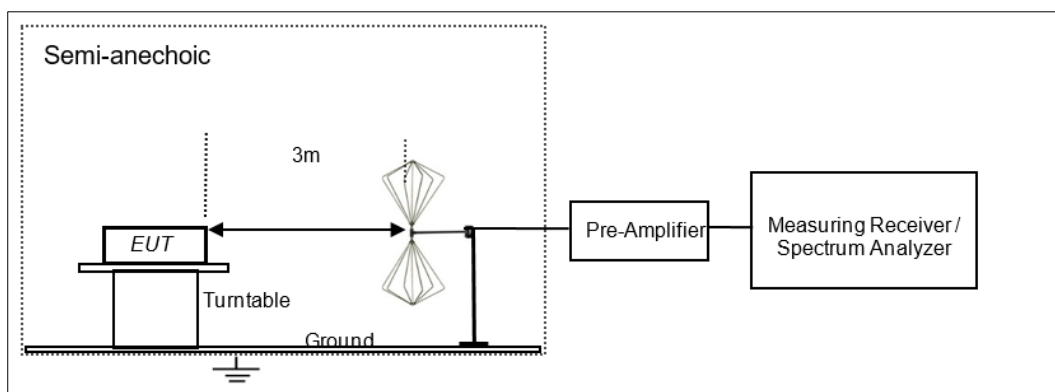

Figure 2: Frequency Range 30 MHz – 200 MHz

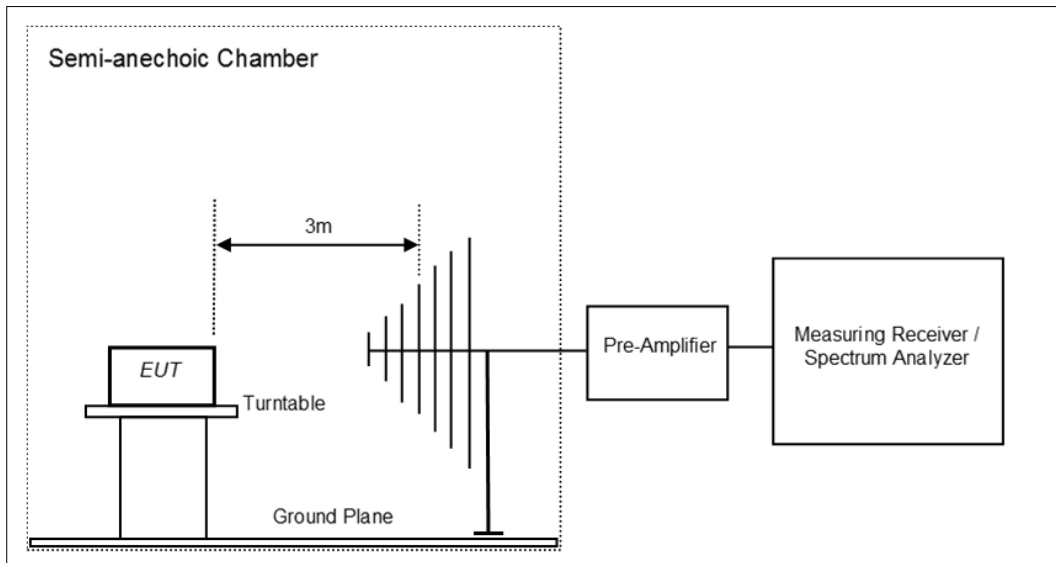

Figure 3: Frequency Range 200 MHz - 1GHz

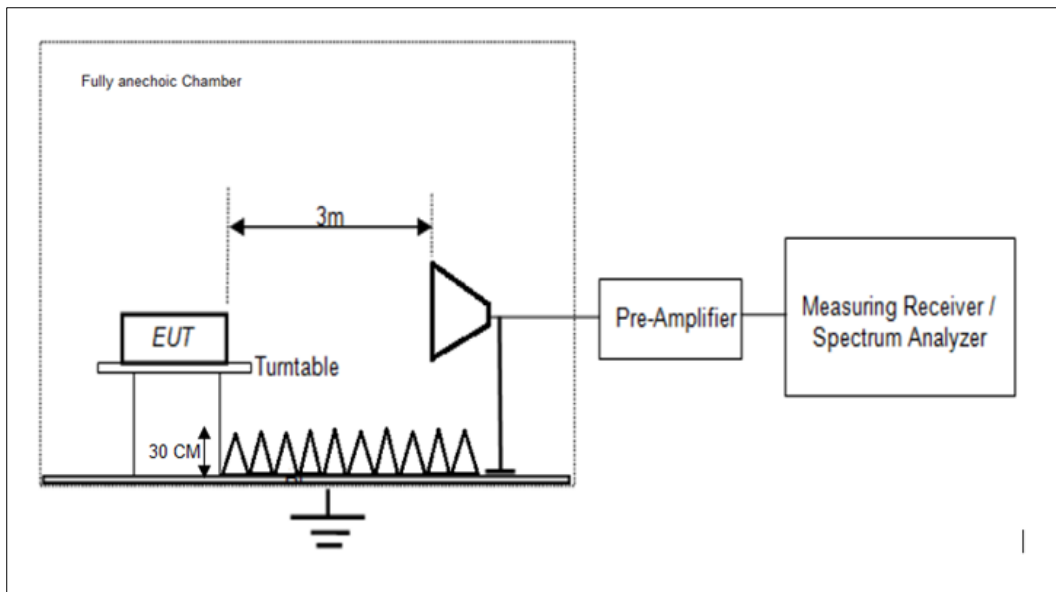

Figure 4: Frequency Range above 1 GHz

Prüfbericht - Nr.:
Test Report No.:

ULR-TC568822300000092F

Seite 17 von 53
Page 17 of 53

7 TEST RESULTS FOR Wi-Fi

7.1 Maximum Average Conducted Output Power

Result

Pass

Test Specification	FCC part 15 Subpart C 15.247 (b)(3)
Test Method	Subclause 11.9.2.3.1 of ANSI C63.10
Detector	Average
Port of testing	Antenna port
Requirement	Power \leq 1 W (30 dBm)

Test Method

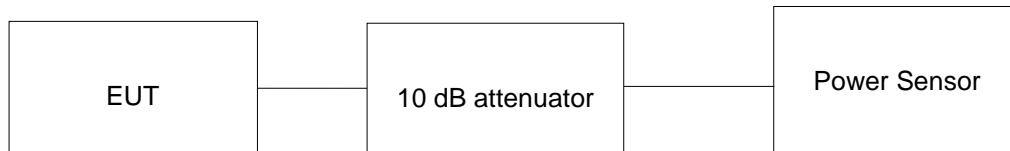

Test Condition

Normal Test Condition:

Temperature (Norm) = + 22.3 °C Voltage = 110V AC and 60 Hz supply Relative humidity: 62%

KDB Guidelines applied:

Measurements were made as per section 8.3.2 in KDB 558074 D01 15.247 Measurement Guidance v05r02.

Prüfbericht - Nr.:
Test Report No.:

ULR-TC568822300000092F

Seite 18 von 53
Page 18 of 53

Test results:

Note:

1. All the losses are included during measurement and final values are mentioned in the test report.
2. Total Average Output power (dBm) = Measured Average power (dBm) + Attenuator factor (10dB) + Cable loss (0.6dB)
3. This product do not support additional beamforming gain / directional gain, it uses signal antenna and hence directional gain of the single antenna is 2.00 dBi

Modulation: 802.11b

Data rate	Channel Frequency (MHz)	Measured Power (dBm)	Power Limit (dBm)
1Mbps	2412	14.70	30
	2437	14.42	30
	2462	14.34	30

Modulation: 802.11g

Data rate	Channel Frequency (MHz)	Measured Power (dBm)	Power Limit (dBm)
6Mbps	2412	11.55	30
	2442	14.14	30
	2462	11.21	30

Modulation: 802.11n_20MHz

Data rate	Channel Frequency (MHz)	Measured Power (dBm)	Power Limit (dBm)
MCS0	2412	11.73	30
	2437	13.49	30
	2462	11.50	30

Modulation: 802.11n_40MHz

Data rate	Channel Frequency (MHz)	Measured Power (dBm)	Power Limit (dBm)
MCS0	2422	12.02	30
	2437	11.88	30
	2457	11.83	30

7.2 Spurious Radiated Emissions & Restricted Bands of Operation

Result	Pass
Test Specification	FCC part 15 Subpart C 15.247 (d) / (15.209 & 15.205)
Test Method	ANSI C63.10.2013
Measurement Location	Semi Anechoic Chamber 30MHz - 1 GHz Fully Anechoic Chamber 1 GHz - 40GHz
Measurement Bandwidth	100 kHz for frequency range < 1GHz 1 MHz for Frequency range >1GHz
Detector	Refer remarks below
Measuring Distance	3 m
Requirement	As per the limits mentioned in the below table
Test setup	Refer Clause 7 TEST METHODOLOGY

Table 7: Transmitter limits for Radiated emission

Frequency (MHz)	Field strength (μV/m)	Field strength (dBμV/m)	Distance of Measurement (m)
0.009 – 0.490	2400/F(kHz)	48.50 – 13.80	300*
0.490 – 1.705	24000/F(kHz)	33.80 – 23.00	30*
1.705 -30	30	29.54	30*
30-88	100	40.0	3
88-216	150	43.5	3
216-960	200	46.0	3
Above 960	500	54.00	3

Remark: * The limit shows in the table above of frequency range 0.009 – 0.490, 0.490 – 1.705 MHz and 1.705-30MHz is at 300 meter, 30 meter and 30 meter range respectively, which corresponds to 128.51 – 93.80, 73.80 – 62.96 and 69.54.00 dBμV/m at 3m range by extrapolation calculation and the measurement of loop antenna.

The emission limits shown in the above table are based on measurements employing a CISPR quasi-peak detector except for the frequency bands 9–90 kHz, 110–490 kHz and above 1000 MHz Radiated emission limits in these three bands are based on measurements employing an average detector.

Test Conditions:

Temperature (Norm) = + 22.5 °C

Voltage = 110V AC 60 Hz Supply

Relative humidity = 62 %

Prüfbericht - Nr.:
Test Report No.:

ULR-TC56882230000092F

Seite 20 von 53
Page 20 of 53

Test results:

Note: All the losses are included during measurement and final values are mentioned in the test report. Refer Clause 7 TEST METHODOLOGY for more details

Test results for frequency range 9kHz – 30MHz

No emissions found in frequency range 9 kHz to 30 MHz, and measured levels are below 20dB from the limit line, hence not reported

Test results for frequency range 30MHz – 1GHz

Antenna Polarization	Measured Frequency (MHz)	Measured Quasi peak value (dB μ V/m)	Limit (dB μ V/m)	Margin (dB)
Vertical	54.708	28.96	39.6	-10.64
	79.998	30.43	39.6	-9.17
	95.982	40.84	43.5	-2.66
	98.67	27.30	43.5	-16.20
	111.99	38.44	43.5	-5.06
	143.994	37.39	43.5	-6.11
	416	40.90	46	-5.10
	447.98	32.59	46	-13.41
	599.966	31.52	46	-14.48
	831.992	37.76	46	-8.24
Horizontal	79.914	32.64	39.6	-6.96
	98.154	33.58	43.5	-9.92
	112.002	42.51	43.5	-0.99
	127.998	37.38	43.5	-6.12
	140.04	39.22	43.5	-4.28
	144.024	40.60	43.5	-2.90
	255.992	39.89	46	-6.11
	447.992	39.52	46	-6.48
	479.978	37.75	46	-8.25
	744.716	39.59	46	-6.41
	832.004	41.17	46	-4.83
	848	37.91	46	-8.09

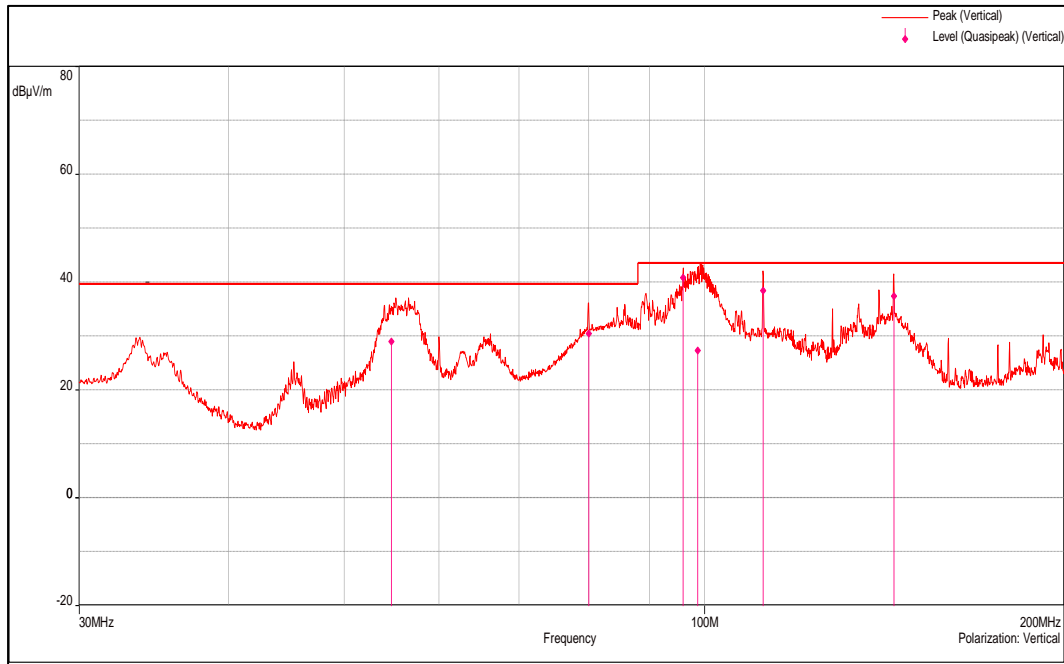

Channel Frequency 30MHz – 200MHz

Polarization Vertical

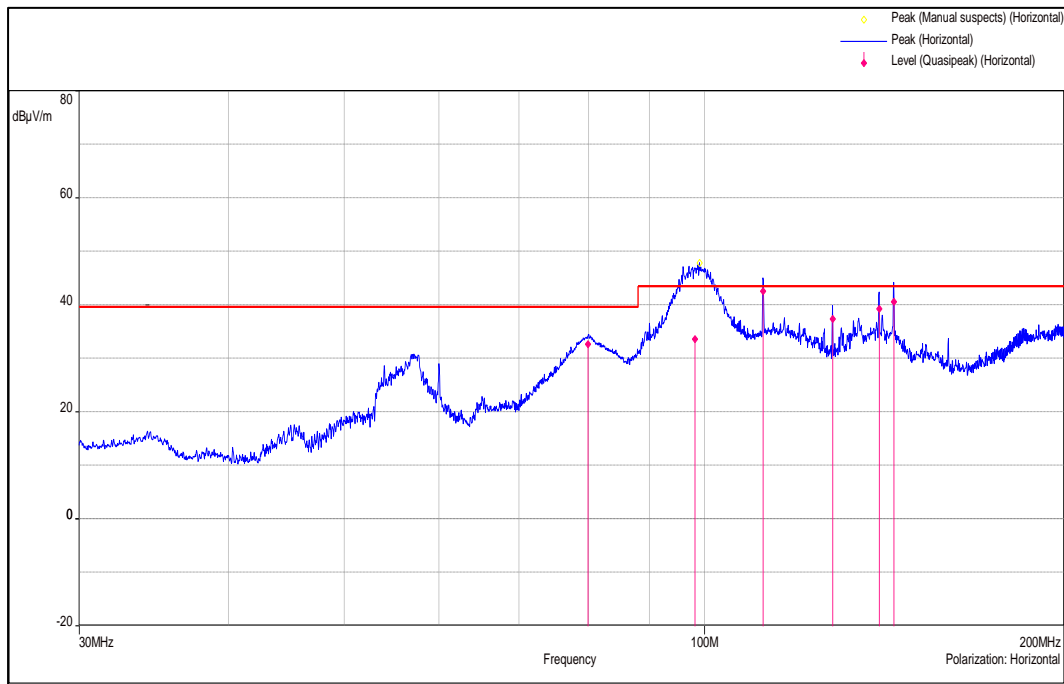

Channel Frequency 30MHz – 200MHz

Polarization Horizontal

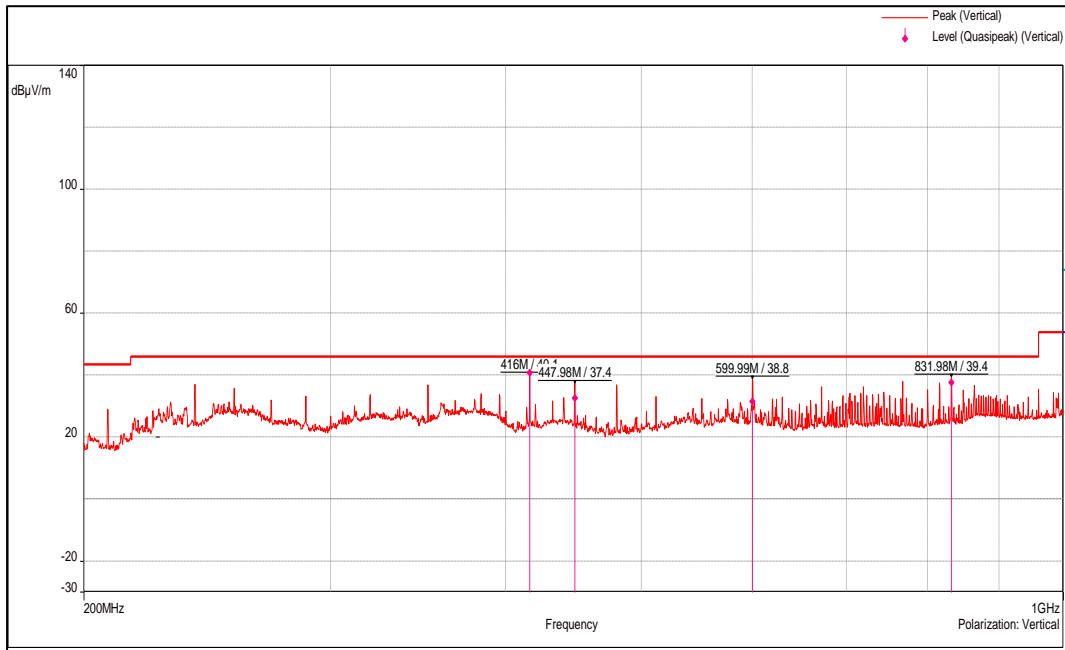

Channel Frequency 200MHz – 1GHz

Polarization Vertical

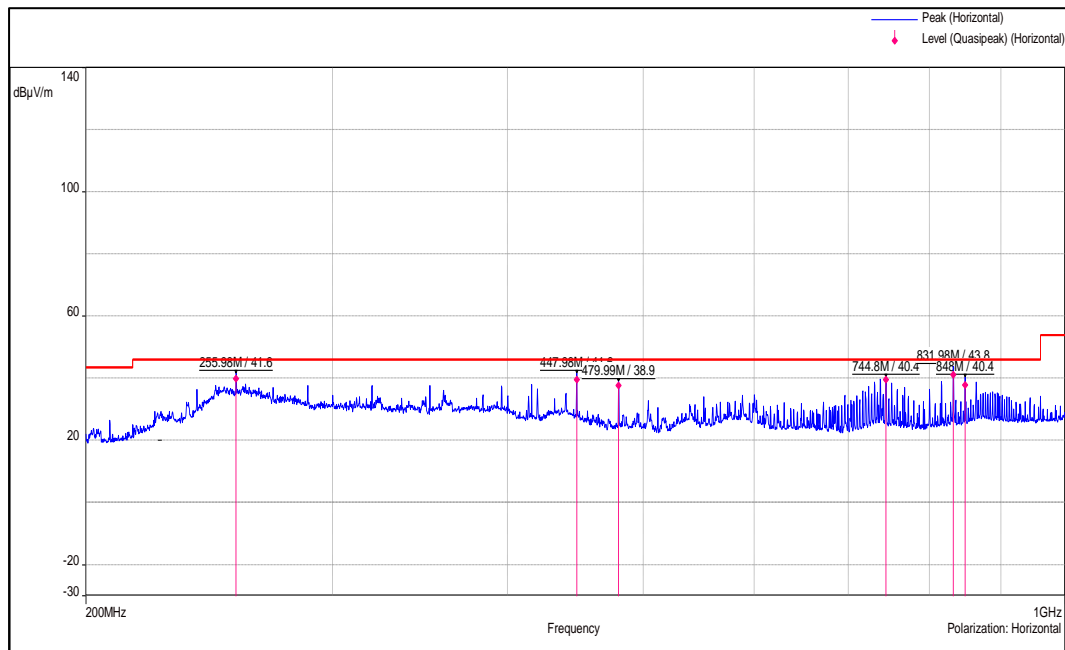

Channel Frequency 200MHz – 1GHz

Polarization Horizontal

Prüfbericht - Nr.:
Test Report No.:

ULR-TC56882230000092F

Seite 23 von 53
Page 23 of 53

Test results for the frequencies in the range 1 GHz to 26.5 GHz

Modulation: 802.11b

Data Rate: 1Mbps

Channel Frequency (MHz)	Frequency (MHz)	antenna Polarization	Emission (dBµV/m)	Limit (dBµV/m)	Margin (dB)
2412	2412(Pk)	Vertical	87.73	-	-
	2412(Av)		85.23	-	-
	2390(Pk)		38.26	74.00*	-35.74
	2390(Av)		25.35	54.00*	-28.65
	4824(Pk)		43.03	74.00	-30.97
	4824(Av)		37.76	54.00	-16.24
	7236(Pk)		46.92	74.00	-27.08
	7236(Av)		34.81	54.00	-19.19
	2412(Pk)	Horizontal	86.42	-	-
	2412(Av)		83.80	-	-
	2390(Pk)		37.67	74.00*	-36.33
	2390(Av)		25.21	54.00*	-28.79
	4824(Pk)		42.18	74.00	-31.82
	4824(Av)		31.09	54.00	-22.91
	7236(Pk)		47.30	74.00	-26.70
	7236(Av)		34.73	54.00	-19.27
2437	2437(Pk)	Vertical	89.18	-	-
	2437(Av)		86.55	-	-
	4874(Pk)		42.71	74.00	-31.29
	4874(Av)		33.90	54.00	-20.10
	7311(Pk)		47.06	74.00	-26.94
	7311(Av)		34.98	54.00	-19.02
	2437(Pk)	Horizontal	88.48	-	-
	2437(Av)		85.91	-	-
	4874(Pk)		43.59	74.00	-30.41
	4874(Av)		32.89	54.00	-21.11
	7311(Pk)		47.10	74.00	-26.90
	7311(Av)		34.99	54.00	-19.01
2462	2462(Pk)	Vertical	91.03	-	-
	2462(Av)		88.41	-	-
	2483.5(Pk)		40.63	74.00*	-33.37
	2483.5(Av)		27.45	54.00*	-26.55
	4924(Pk)		43.87	74.00	-30.13
	4924(Av)		34.97	54.00	-19.03
	7386(Pk)		47.03	74.00	-26.97
	7386(Av)		34.82	54.00	-19.18
	2462(Pk)	Horizontal	90.01	-	-
	2462(Av)		87.40	-	-
	2483.5(Pk)		39.37	74.00*	-34.63
	2483.5(Av)		26.95	54.00*	-27.05
	4924(Pk)		42.30	74.00	-31.70
	4924(Av)		32.27	54.00	-21.73
	7386(Pk)		46.90	74.00	-27.10
	7386(Av)		34.74	54.00	-19.26

* : Indicate restricted band of operation §15.205
Pk: Peak Detector; Av: Average Detector

Modulation: 802.11g
Data Rate: 6Mbps

Channel Frequency (MHz)	Frequency (MHz)	Antenna Polarization	Emission (dBµV/m)	Limit (dBµV/m)	Margin (dB)
2412	2412(Pk)	Vertical	89.64	-	-
	2412(Av)		79.51	-	-
	2390(Pk)		53.33	74.00*	-20.67
	2390(Av)		31.06	54.00*	-22.94
	4824(Pk)		41.95	74.00	-32.05
	4824(Av)		29.15	54.00	-24.85
	7236(Pk)		46.98	74.00	-27.02
	7236(Av)		34.60	54.00	-19.40
	2412(Pk)	Horizontal	88.70	-	-
	2412(Av)		78.56	-	-
	2390(Pk)		53.69	74.00*	-20.31
	2390(Av)		31.72	54.00*	-22.28
	4824(Pk)		41.26	74.00	-32.74
	4824(Av)		29.17	54.00	-24.83
	7236(Pk)		47.34	74.00	-26.66
	7236(Av)		34.61	54.00	-19.39
2437	2437(Pk)	Vertical	93.92	-	-
	2437(Av)		83.30	-	-
	4874(Pk)		40.98	74.00	-33.02
	4874(Av)		28.96	54.00	-25.04
	7311(Pk)		46.23	74.00	-27.77
	7311(Av)		34.31	54.00	-19.69
	2437(Pk)	Horizontal	92.64	-	-
	2437(Av)		82.01	-	-
	4874(Pk)		41.07	74.00	-32.93
	4874(Av)		28.59	54.00	-25.41
	7311(Pk)		46.48	74.00	-27.52
	7311(Av)		34.08	54.00	-19.92
2462	2462(Pk)	Vertical	92.14	-	-
	2462(Av)		81.75	-	-
	2483.5(Pk)		58.70	74.00*	-15.30
	2483.5(Av)		34.90	54.00*	-19.10
	4924(Pk)		40.50	74.00	-33.50
	4924(Av)		28.72	54.00	-25.28
	7386(Pk)		46.90	74.00	-27.10
	7386(Av)		34.25	54.00	-19.75
	2462(Pk)	Horizontal	92.01	-	-
	2462(Av)		81.70	-	-
	2483.5(Pk)		58.42	74.00*	-15.58
	2483.5(Av)		34.68	54.00*	-19.32
	4924(Pk)		40.72	74.00	-33.28
	4924(Av)		28.71	54.00	-25.29
	7386(Pk)		47.87	74.00	-26.13
	7386(Av)		34.27	54.00	-19.73

* : Indicate restricted band of operation §15.205
Pk: Peak Detector; Av: Average Detector

Prüfbericht - Nr.:
Test Report No.:

ULR-TC568822300000092F

Seite 25 von 53
Page 25 of 53

Modulation: 802.11n_20MHz
Data Rate: MCS0

Channel Frequency (MHz)	Frequency (MHz)	Antenna Polarization	Emission (dBµV/m)	Limit (dBµV/m)	Margin (dB)
2412	2412(Pk)	Vertical	90.98	-	-
	2412(Av)		79.40	-	-
	2390(Pk)		54.72	74.00*	-19.28
	2390(Av)		33.20	54.00*	-20.80
	4824(Pk)		41.09	74.00	-32.91
	4824(Av)		28.80	54.00	-25.20
	7236(Pk)		46.29	74.00	-27.71
	7236(Av)		34.45	54.00	-19.55
	2412(Pk)	Horizontal	91.14	-	-
	2412(Av)		79.65	-	-
	2390(Pk)		56.76	74.00*	-17.24
	2390(Av)		34.68	54.00*	-19.32
	4824(Pk)		40.90	74.00	-33.10
	4824(Av)		28.68	54.00	-25.32
	7236(Pk)		46.65	74.00	-27.35
	7236(Av)		34.40	54.00	-19.60
2437	2437(Pk)	Vertical	92.99	-	-
	2437(Av)		81.90	-	-
	4874(Pk)		41.73	74.00	-32.27
	4874(Av)		29.01	54.00	-24.99
	7311(Pk)		47.65	74.00	-26.35
	7311(Av)		34.56	54.00	-19.44
	2437(Pk)	Horizontal	93.67	-	-
	2437(Av)		82.19	-	-
	4874(Pk)		41.33	74.00	-32.67
	4874(Av)		29.03	54.00	-24.97
	7311(Pk)		47.25	74.00	-26.75
	7311(Av)		34.60	54.00	-19.40
2462	2462(Pk)	Vertical	94.04	-	-
	2462(Av)		82.60	-	-
	2483.5(Pk)		62.83	74.00*	-11.17
	2483.5(Av)		37.86	54.00*	-16.14
	4924(Pk)		40.55	74.00	-33.45
	4924(Av)		28.69	54.00	-25.31
	7386(Pk)		46.05	74.00	-27.95
	7386(Av)		34.53	54.00	-19.47
	2462(Pk)	Horizontal	91.60	-	-
	2462(Av)		80.26	-	-
	2483.5(Pk)		58.75	74.00*	-15.25
	2483.5(Av)		36.17	54.00*	-17.83
	4924(Pk)		40.89	74.00	-33.11
	4924(Av)		29.22	54.00	-24.78
	7386(Pk)		46.97	74.00	-27.03
	7386(Av)		34.91	54.00	-19.09

* : Indicate restricted band of operation §15.205
Pk: Peak Detector; Av: Average Detector

Prüfbericht - Nr.:
Test Report No.:

ULR-TC56882230000092F

Seite 26 von 53
Page 26 of 53

Modulation: 802.11n-40MHz
Data Rate: MCS0

Channel Frequency (MHz)	Frequency (MHz)	Antennna Polarization	Emission (dBµV/m)	Limit (dBµV/m)	Margin (dB)
2422	2422(Pk)	Vertical	89.21	-	-
	2422(Av)		77.63	-	-
	2390(Pk)		63.18	74*	-10.82
	2390(Av)		45.20	54*	-8.80
	4844(Pk)		40.84	74	-33.16
	4844(Av)		28.54	54	-25.46
	7266(Pk)		46.14	74	-27.86
	7266(Av)		34.23	54	-19.77
	2422(Pk)	Horizontal	85.94	-	-
	2422(Av)		75.06	-	-
	2390(Pk)		61.59	74*	-12.41
	2390(Av)		43.68	54*	-10.32
	4844(Pk)		41.73	74	-32.27
	4844(Av)		28.61	54	-25.39
	7266(Pk)		46.37	74	-27.63
	7266(Av)		34.33	54	-19.67
2437	2437(Pk)	Vertical	89.69	-	-
	2437(Av)		78.00	-	-
	4874(Pk)		41.31	74	-32.69
	4874(Av)		28.88	54	-25.12
	7311(Pk)		46.38	74	-27.62
	7311(Av)		34.53	54	-19.47
	2437(Pk)	Horizontal	89.41	-	-
	2437(Av)		77.46	-	-
	4874(Pk)		40.51	74	-33.49
	4874(Av)		28.73	54	-25.27
	7311(Pk)		45.63	74	-28.37
	7311(Av)		34.42	54	-19.58
2457	2457(Pk)	Vertical	91.42	-	-
	2457(Av)		80.23	-	-
	2483.5(Pk)		68.36	74*	-5.64
	2483.5(Av)		50.20	54*	-3.80
	4914(Pk)		40.54	74	-33.46
	4914(Av)		28.92	54	-25.08
	7371(Pk)		47.01	74	-26.99
	7371(Av)		34.55	54	-19.45
	2457(Pk)	Horizontal	91.26	-	-
	2457(Av)		79.44	-	-
	2483.5(Pk)		67.70	74*	-6.30
	2483.5(Av)		49.08	54*	-4.92
	4914(Pk)		40.28	74	-33.72
	4914(Av)		28.81	54	-25.19
	7371(Pk)		46.53	74	-27.47
	7371(Av)		34.57	54	-19.43

* : Indicate restricted band of operation §15.205
Pk: Peak Detector; Av: Average Detector

Test Plots

Data Rate: 1Mbps

Channel Frequency 2462MHz

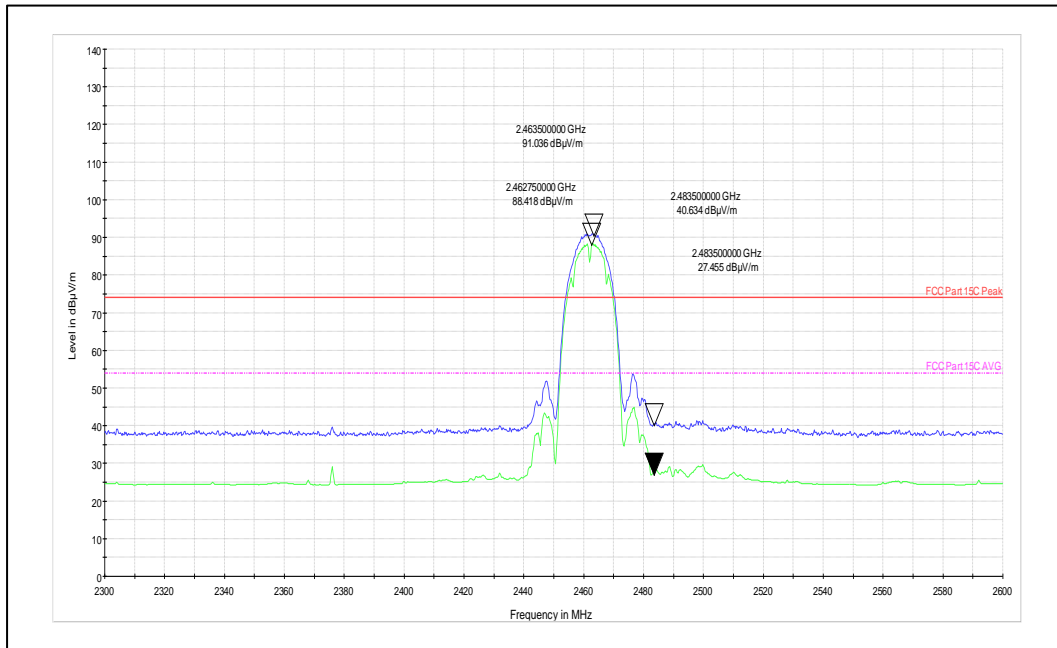

Channel Frequency: 2462MHz

Polarization: Vertical

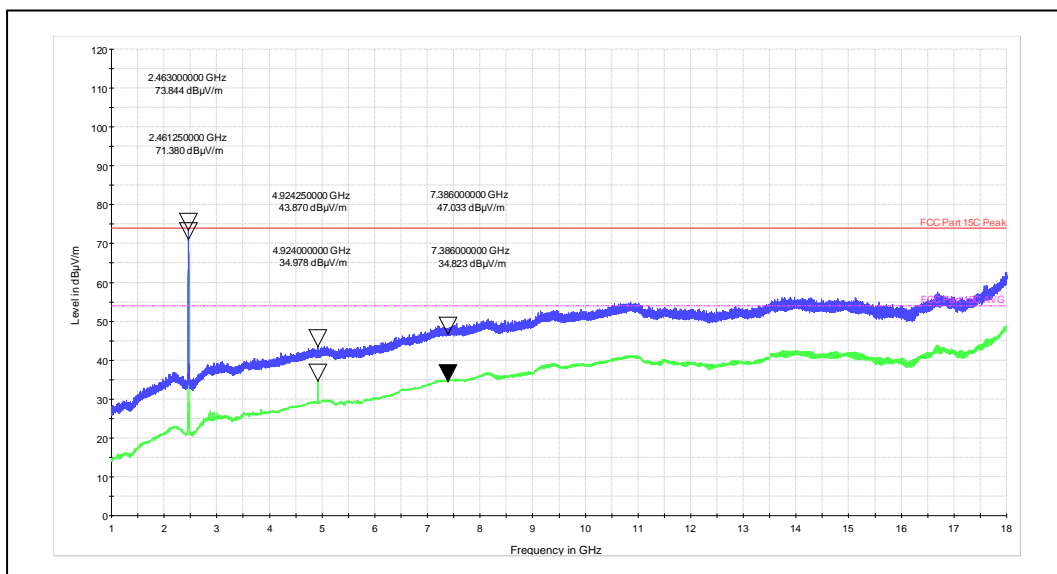

Channel Frequency: 1GHz – 18 GHz

Polarization: Vertical

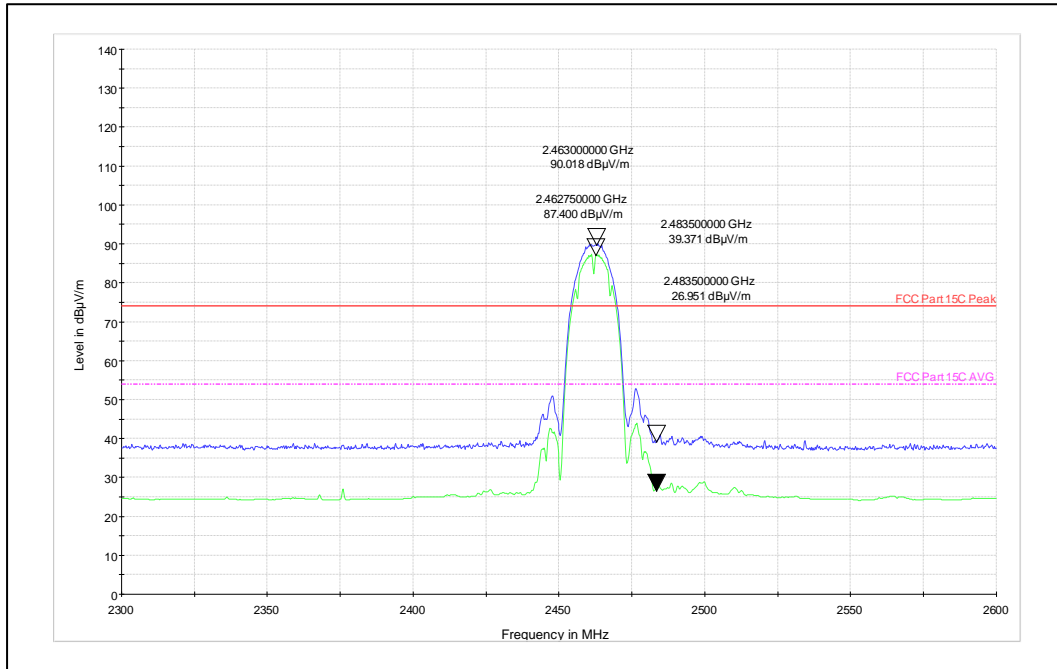

Channel Frequency: 2462MHz

Polarization: Horizontal

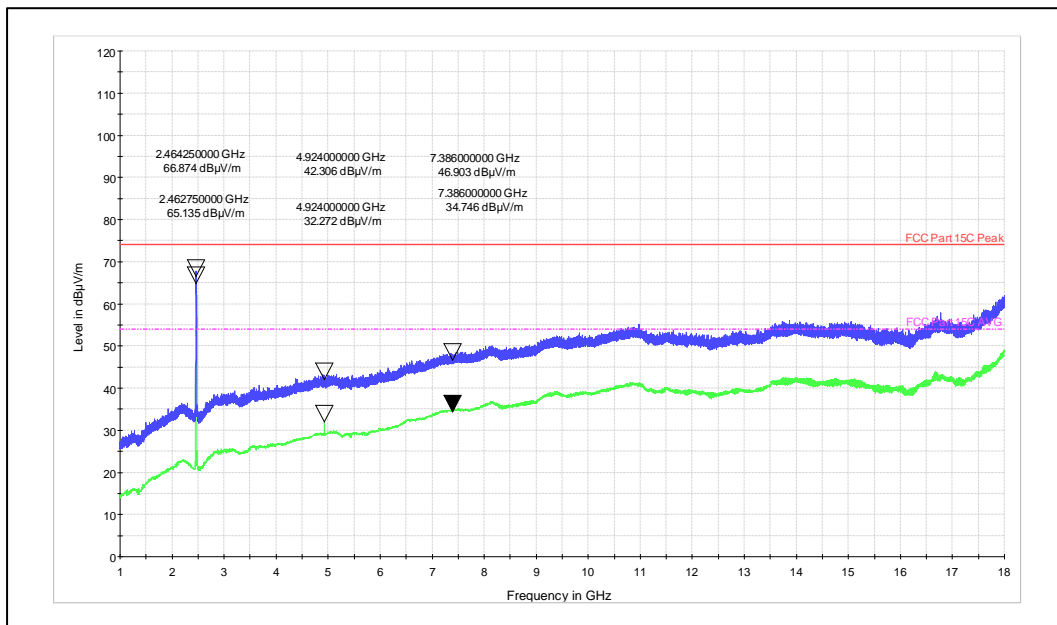

Channel Frequency: 1GHz – 18 GHz

Polarization: Horizontal

Data Rate: 6Mbps

Channel Frequency 2437MHz

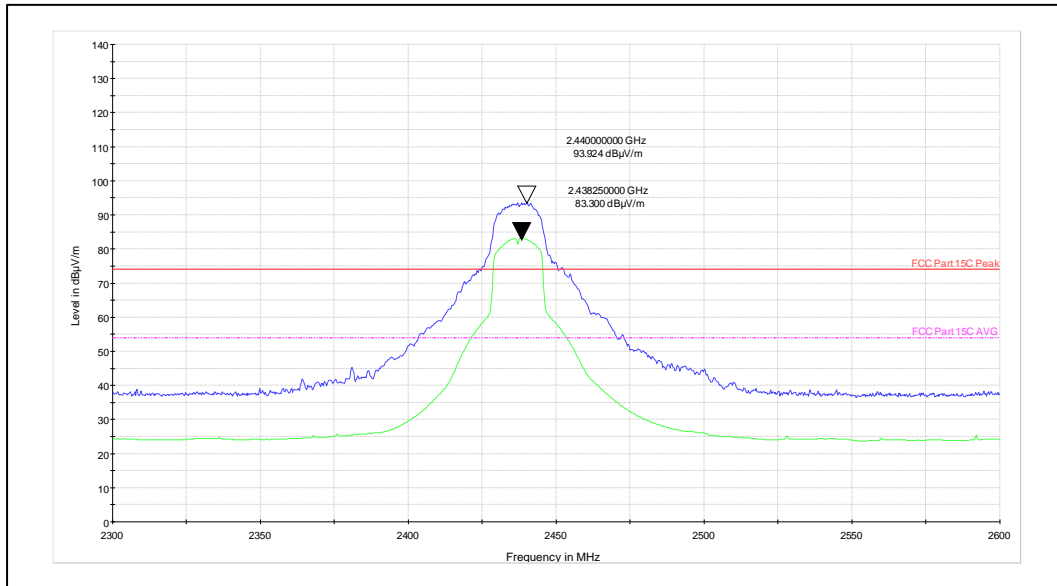

Channel Frequency: 2437MHz

Polarization: Vertical

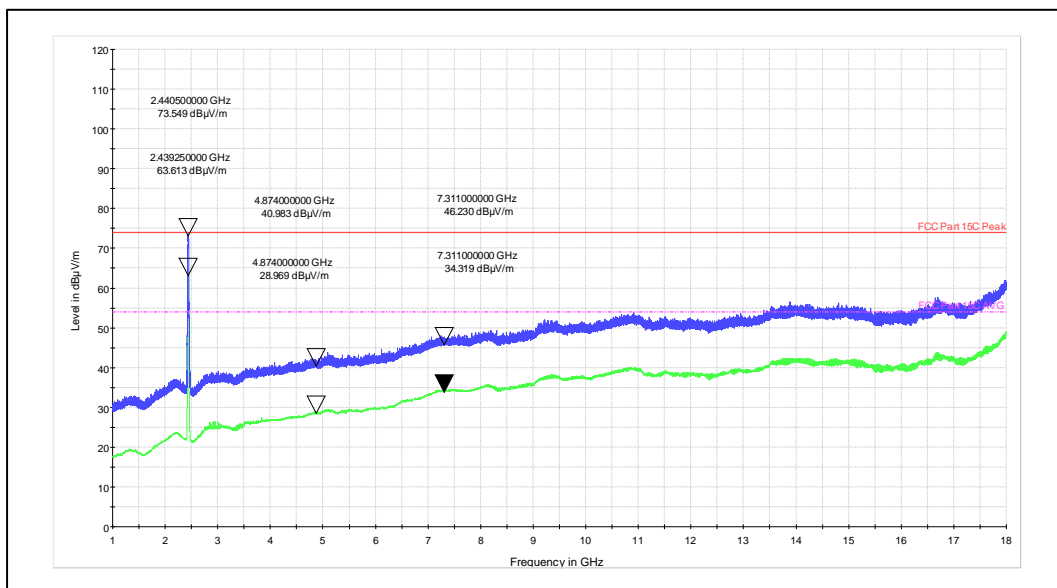

Channel Frequency: 1 GHz – 18 GHz

Polarization: Vertical

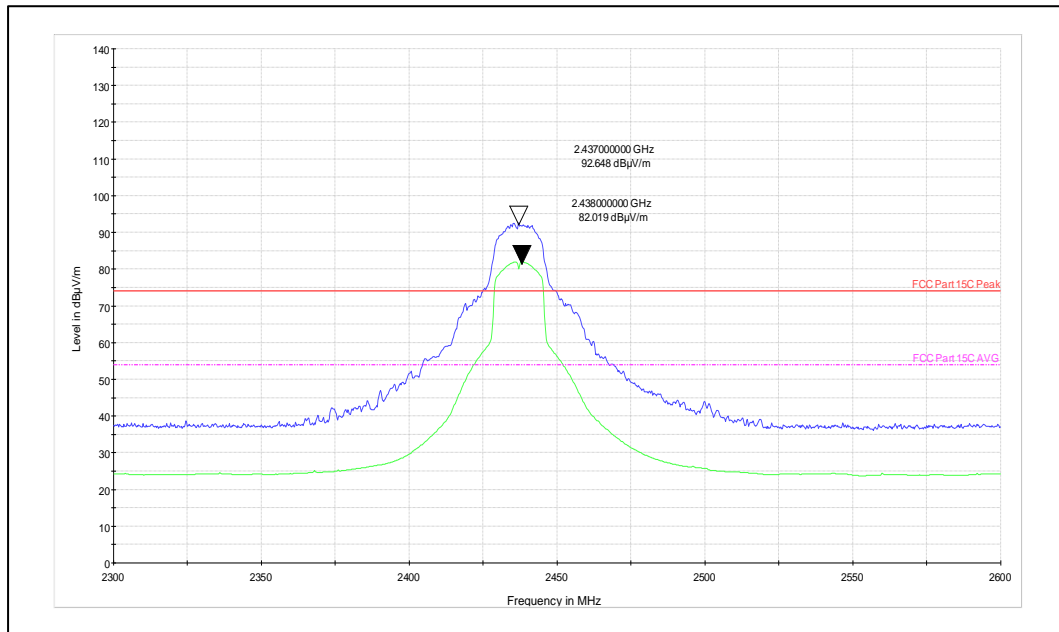

Channel Frequency: 2437MHz

Polarization: Horizontal

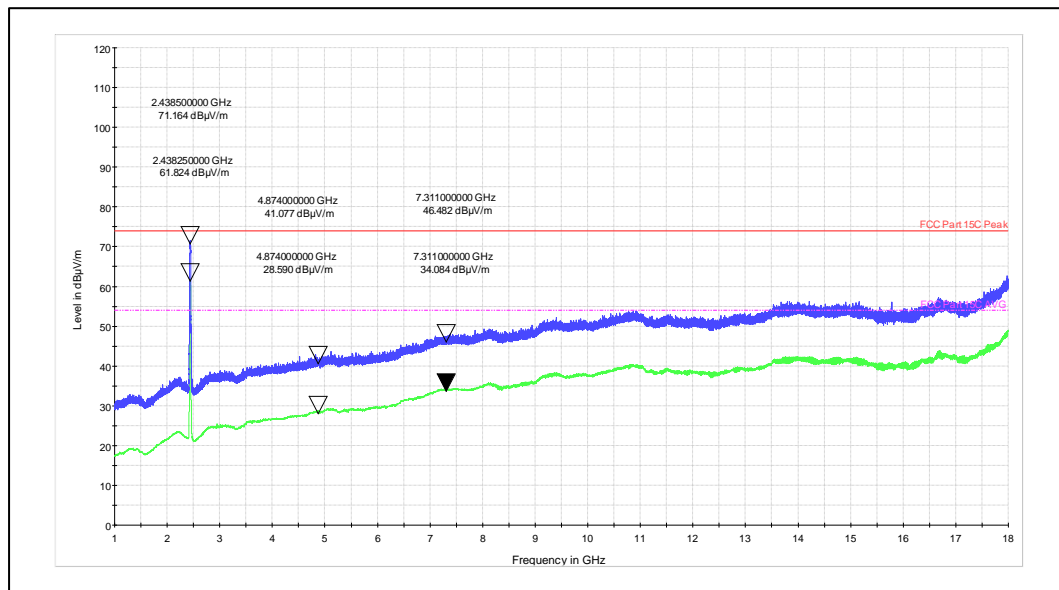

Channel Frequency: 1 GHz – 18 GHz

Polarization: Horizontal

Data Rate: MCS0_n Mode 20MHz

Channel Frequency 2462MHz

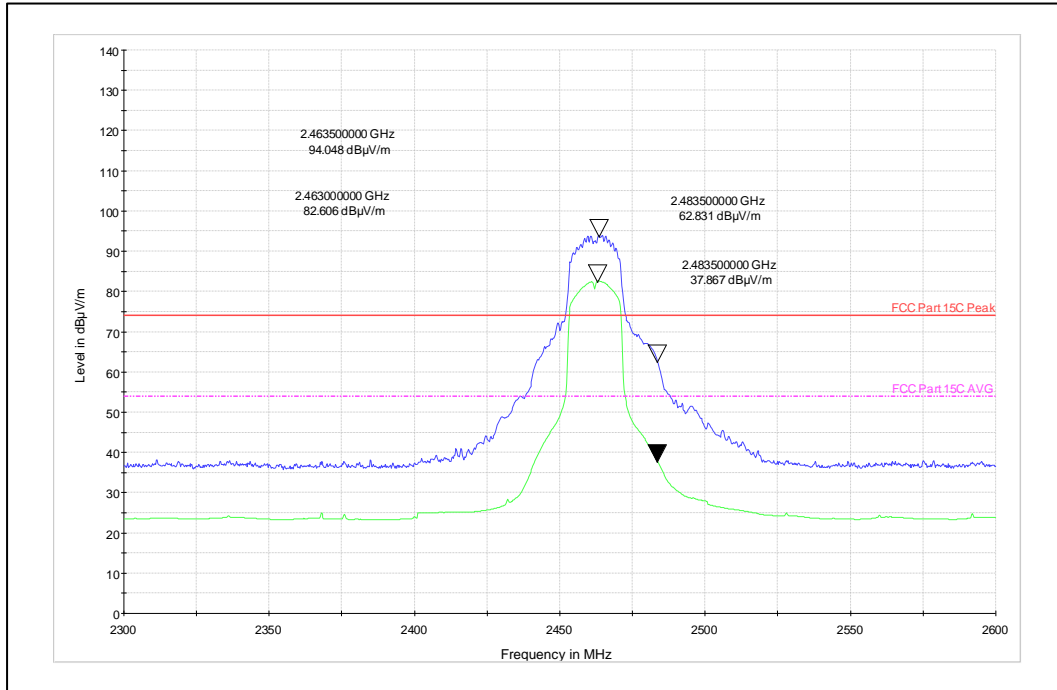

Channel Frequency: 2412MHz

Polarization: Vertical

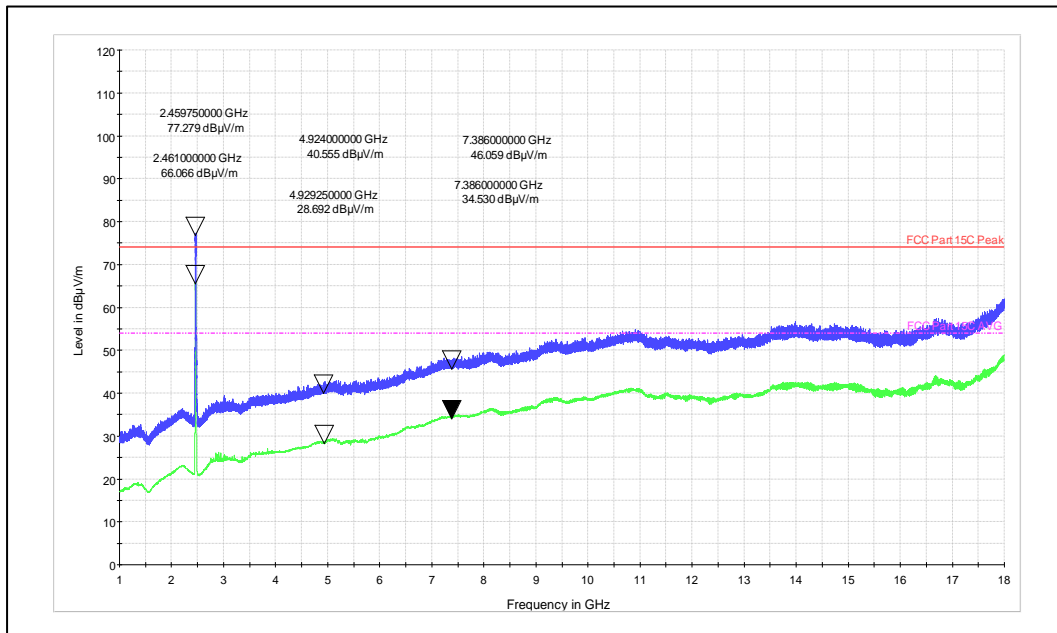

Channel Frequency: 1 GHz – 18 GHz

Polarization: Vertical

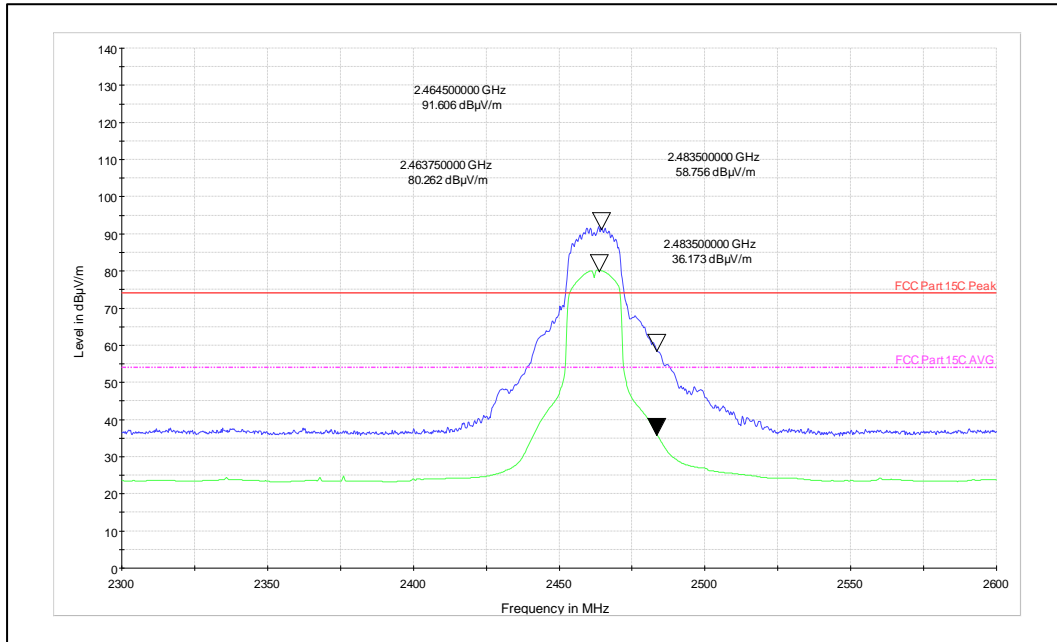

Channel Frequency: 2412MHz

Polarization: Horizontal

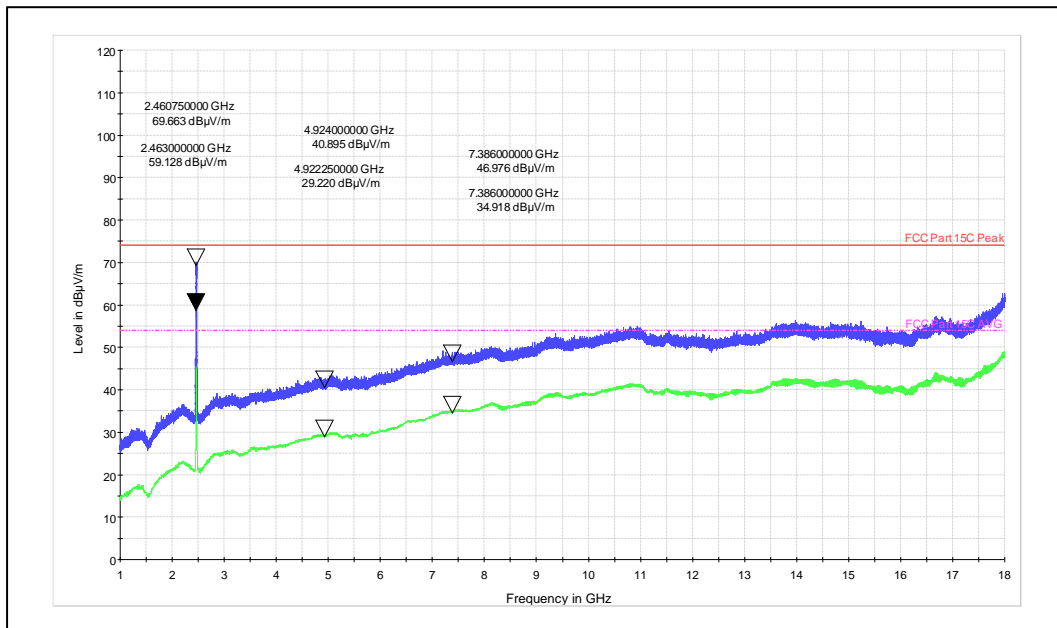

Channel Frequency: 1 GHz– 18 GHz

Polarization: Horizontal

Data rate: MCS0_n Mode 40MHz

Channel Frequency 2457MHz

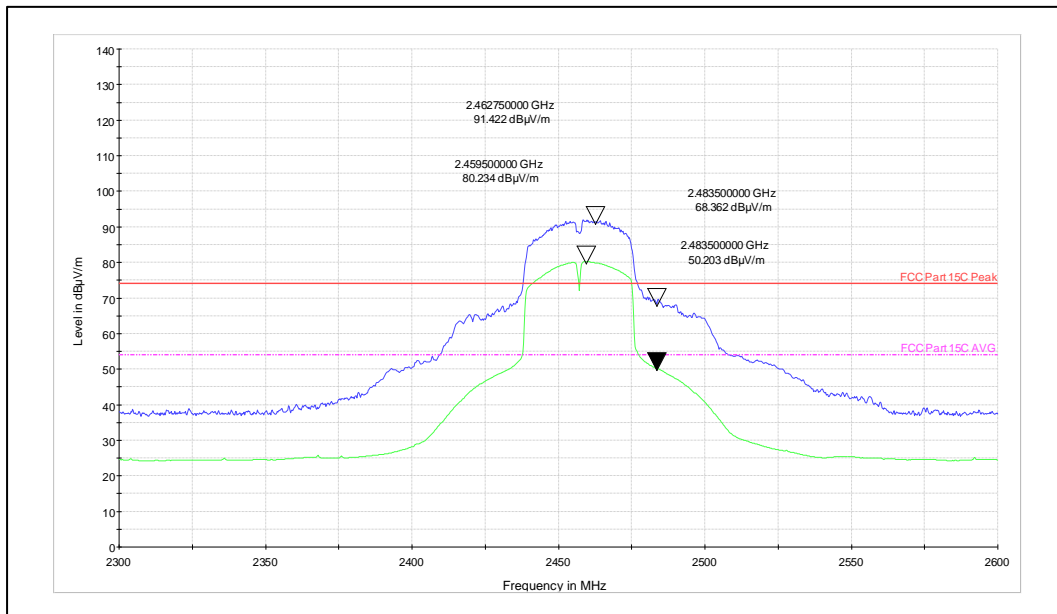

Channel Frequency: 2457MHz

Polarization: Vertical

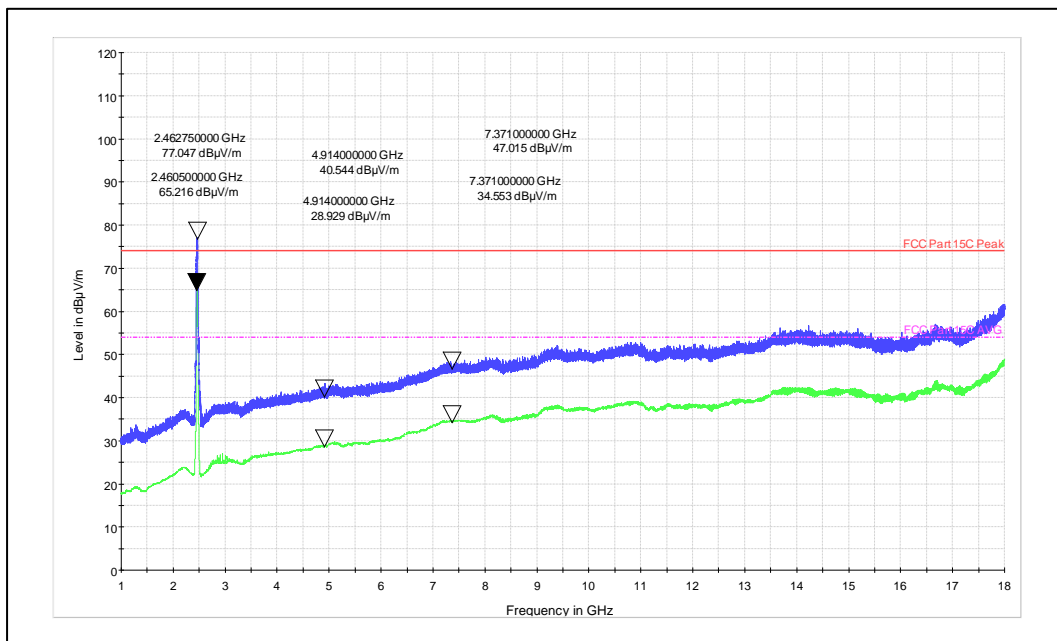

Channel Frequency: 1 GHz – 18 GHz

Polarization: Vertical

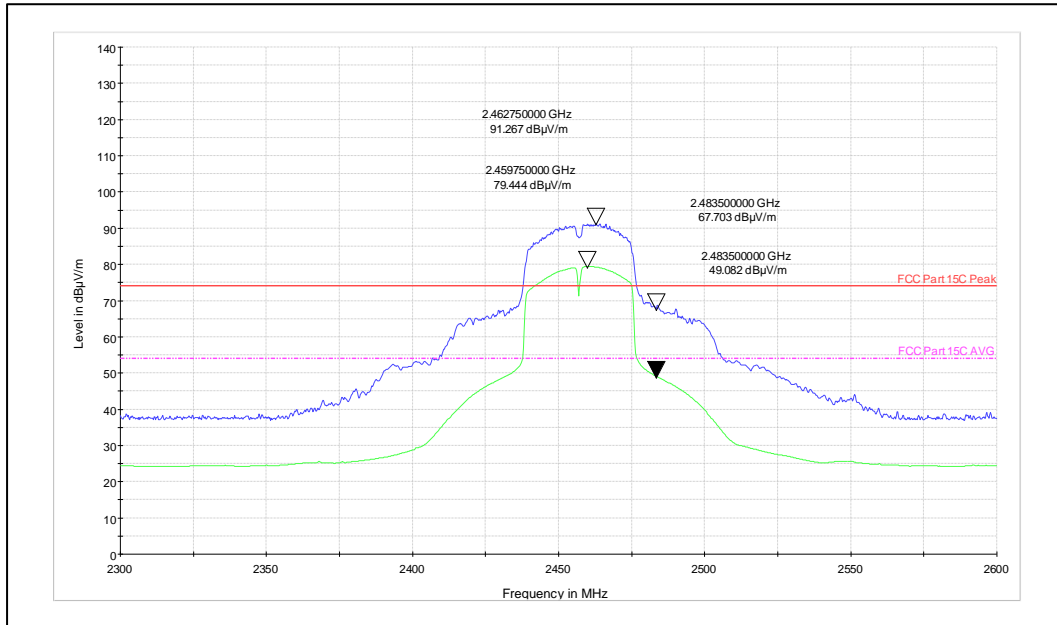

Channel Frequency: 2457MHz

Polarization: Horizontal

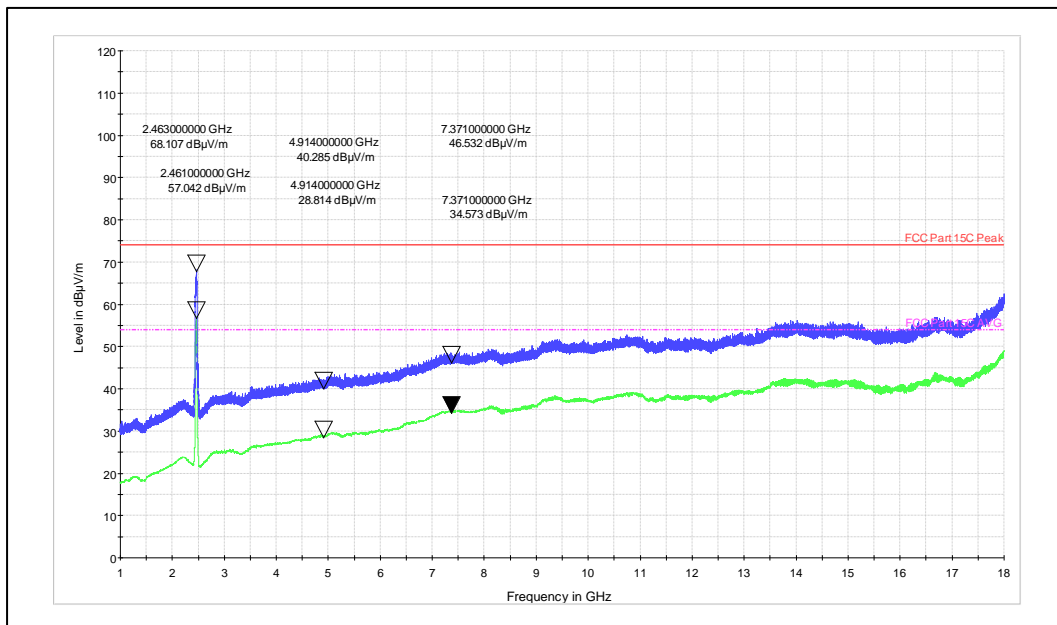

Channel Frequency: 1 GHz– 18 GHz

Polarization: Horizontal

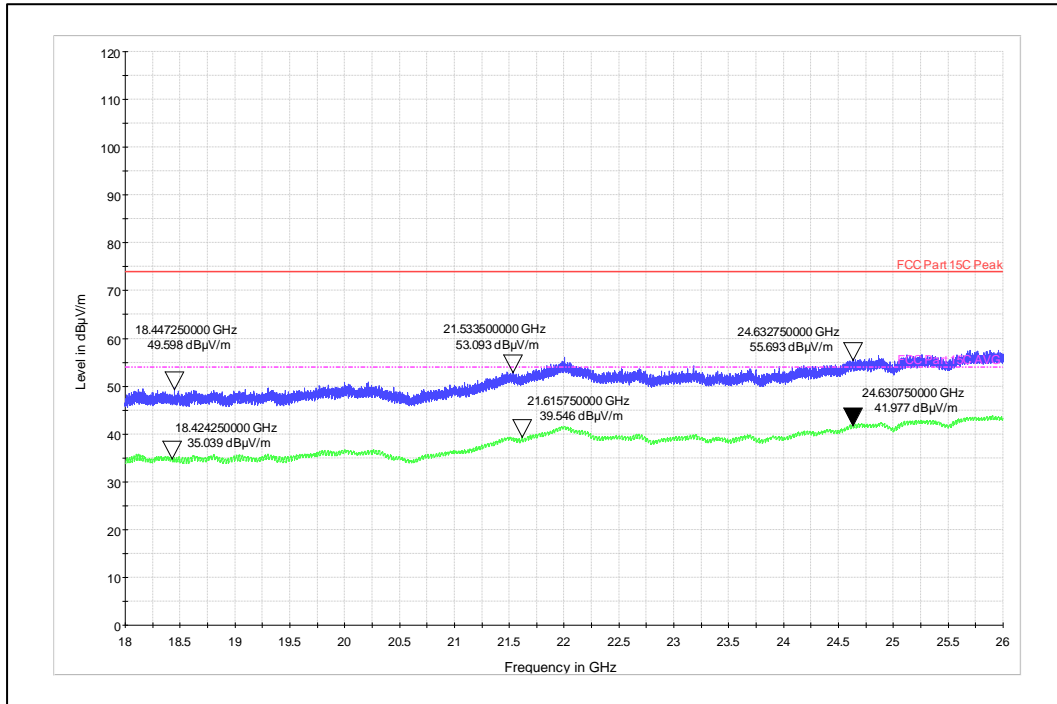

Frequency range: 18GHz to 26GHz

Polarization: Vertical

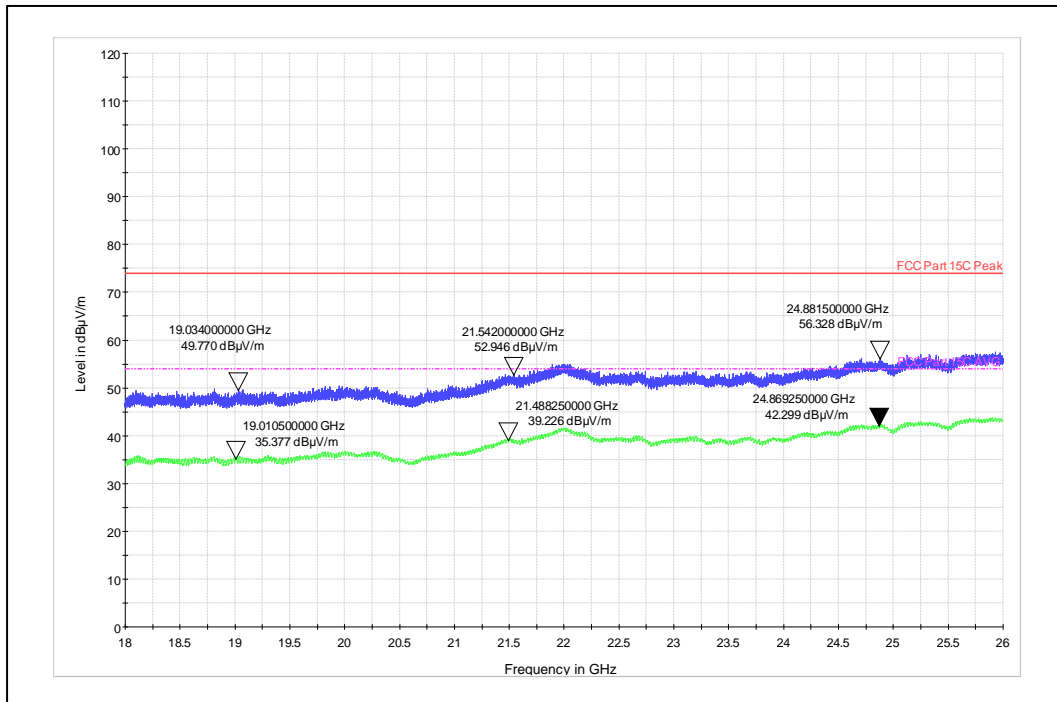

Frequency range: 18GHz to 26GHz

Polarization: Horizontal

Prüfbericht - Nr.:
Test Report No.:

ULR-TC568822300000092F

Seite 36 von 53
Page 36 of 53

8 TEST RESULTS FOR BLUETOOTH LOW ENERGY

8.1 Maximum Peak Conducted Output Power

Result

Pass

Test Specification	FCC part 15 Subpart C 15.247 (b)(3)
Test Method	Subclause 11.9.1.3 of ANSI C63.10
Detector	Peak
Port of testing	Antenna port
Requirement	Power \leq 1 W (30 dBm)

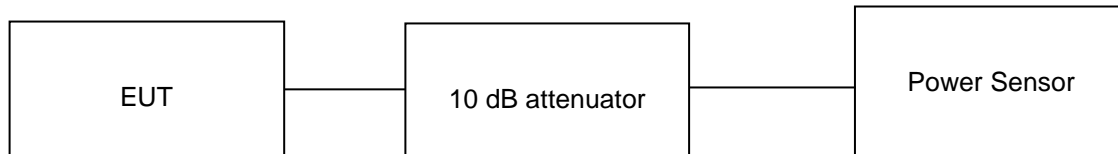

Test Condition

Normal Test Condition:

Temperature (Norm) = + 25 °C

Voltage = 110V AC and 60Hz Supply

Relative humidity: 62%

KDB Guidelines applied:

Measurements were made as per section 8.3.1.3 in KDB 558074.00 D01 15.247 Measurement Guidance v05r02.

Prüfbericht - Nr.:
Test Report No.:

ULR-TC568822300000092F

Seite 37 von 53
Page 37 of 53

Test results:

Note:

1. All the losses are included during measurement and final values are mentioned in the test report.
2. Total Peak Output power (dBm) = Measured Peak power (dBm) + Attenuator factor (10dB) + Cable loss (0.6dB)
3. This product do not support additional beamforming gain / directional gain, it uses signal antenna and hence directional gain of the single antenna is 2.00 dBi

Data Rate	Channel Frequency (MHz)	Measured Peak Power (dBm)	Power Limit (dBm)
1Mbps	2402	5.87	30.00
	2440	5.61	30.00
	2480	5.20	30.00

8.2 Spurious Radiated Emissions & Restricted Bands of Operation

Result	Pass
Test Specification	FCC part 15 Subpart C 15.247 (d) / (15.209 & 15.205)
Test Method	ANSI C63.10.2013
Measurement Location	Semi Anechoic Chamber 30MHz - 1 GHz Fully Anechoic Chamber 1 GHz - 40GHz
Measurement Bandwidth	100 kHz for frequency range < 1GHz 1 MHz for Frequency range >1GHz
Detector	Refer remarks below
Measuring Distance	3 m
Requirement	As per the limits mentioned in the below table
Test setup	Refer TEST METHODOLOGY

Table 8: Transmitter limits for Radiated emission

Frequency (MHz)	Field strength (μV/m)	Field strength (dBμV/m)	Distance of Measurement (m)
0.009 – 0.490	2400/F(kHz)	48.50 – 13.80	300*
0.490 – 1.705	24000/F(kHz)	33.80 – 23.00	30*
1.705 -30	30	29.54.00	30*
30-88	100	40.0	3
88-216	150	43.5	3
216-960	200	46.0	3
Above 960	500	54.00.0	3

Remark: * The limit shows in the table above of frequency range 0.009 – 0.490, 0.490 – 1.705 MHz and 1.705-30MHz is at 300 meter, 30 meter and 30 meter range respectively, which corresponds to 128.51 – 93.80, 73.80 – 62.96 and 69.54.00 dBμV/m at 3m range by extrapolation calculation and the measurement of loop antenna.

The emission limits shown in the above table are based on measurements employing a CISPR quasi-peak detector except for the frequency bands 9–90 kHz, 110–490 kHz and above 1000 MHz Radiated emission limits in these three bands are based on measurements employing an average detector.

Test Conditions:

Temperature (Norm) = + 22.6 °C

Voltage = 12VDC through AC/DC Adaptor

Relative humidity = 62 %

Prüfbericht - Nr.:

ULR-TC56882230000092F

Seite 39 von 53

Test Report No.:

Page 39 of 53

Test results:

Note: All the losses are included during measurement and final values are mentioned in the test report. Refer TEST METHODOLOGY for more details

Test results for frequency range 9kHz – 30MHz

No emissions found in frequency range 9 kHz to 30 MHz, and measured levels are below 20dB from the limit line, hence not reported

Test results for frequency range 30MHz – 1GHz

Antenna Polarization	Measured Frequency (MHz)	Measured Quasi peak value (dBµV/m)	Limit (dBµV/m)	Margin (dB)
Vertical	54.708	28.96	39.6	-10.64
	79.998	30.43	39.6	-9.17
	95.982	40.84	43.5	-2.66
	98.67	27.30	43.5	-16.20
	111.99	38.44	43.5	-5.06
	143.994	37.39	43.5	-6.11
	416	40.90	46	-5.10
	447.98	32.59	46	-13.41
	599.966	31.52	46	-14.48
	831.992	37.76	46	-8.24
Horizontal	79.914	32.64	39.6	-6.96
	98.154	33.58	43.5	-9.92
	112.002	42.51	43.5	-0.99
	127.998	37.38	43.5	-6.12
	140.04	39.22	43.5	-4.28
	144.024	40.60	43.5	-2.90
	255.992	39.89	46	-6.11
	447.992	39.52	46	-6.48
	479.978	37.75	46	-8.25
	744.716	39.59	46	-6.41
	832.004	41.17	46	-4.83
	848	37.91	46	-8.09

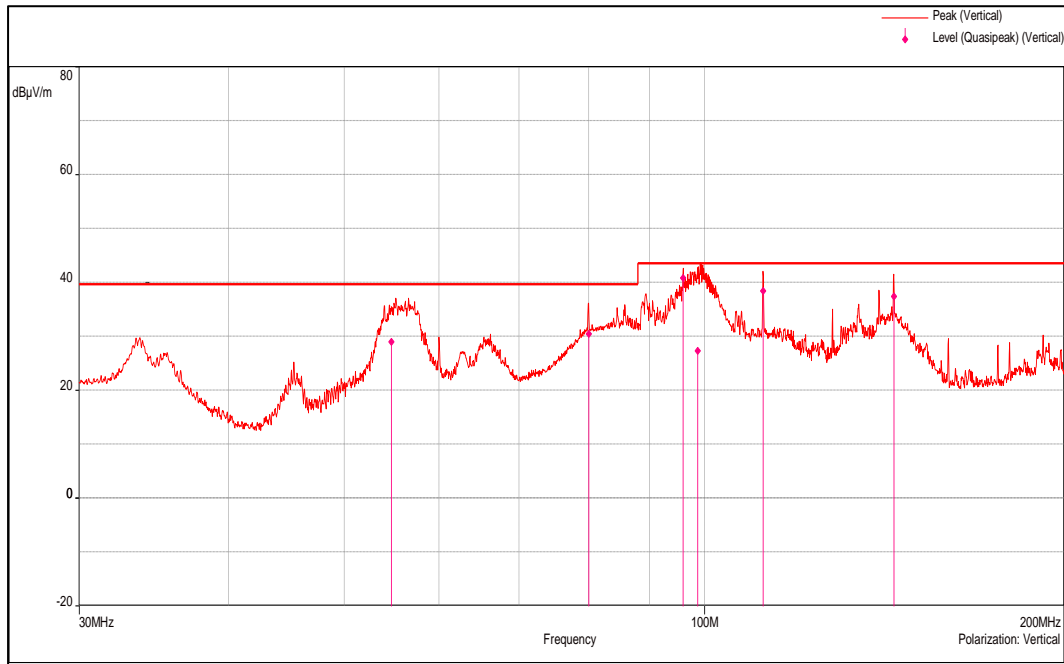

Channel Frequency 30MHz – 200MHz

Polarization Vertical

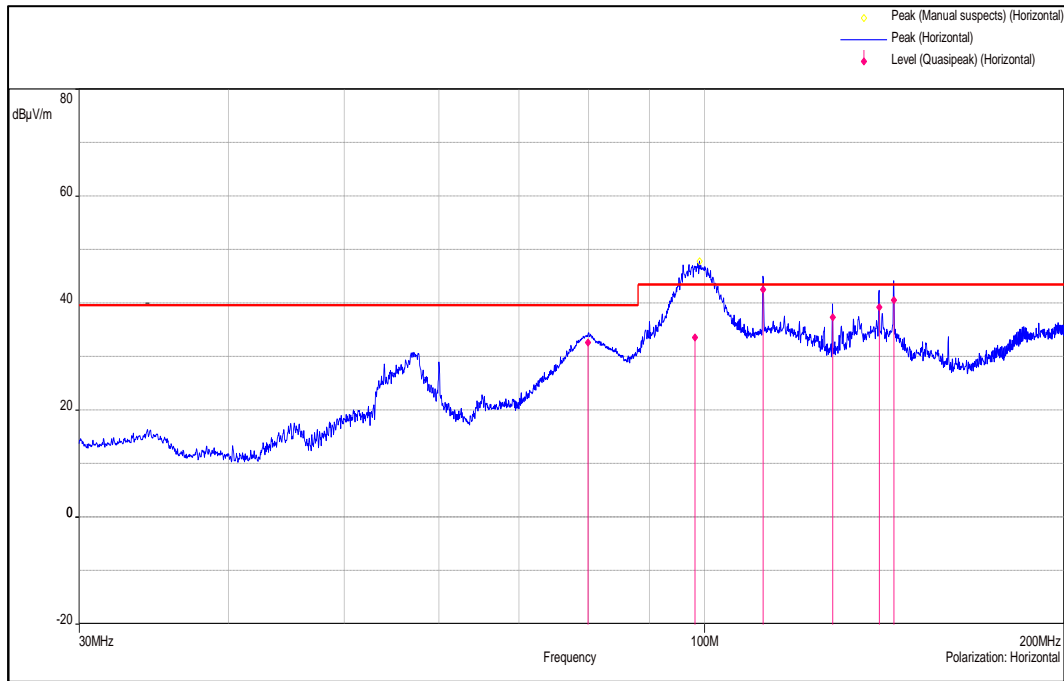

Channel Frequency 30MHz – 200MHz

Polarization Horizontal

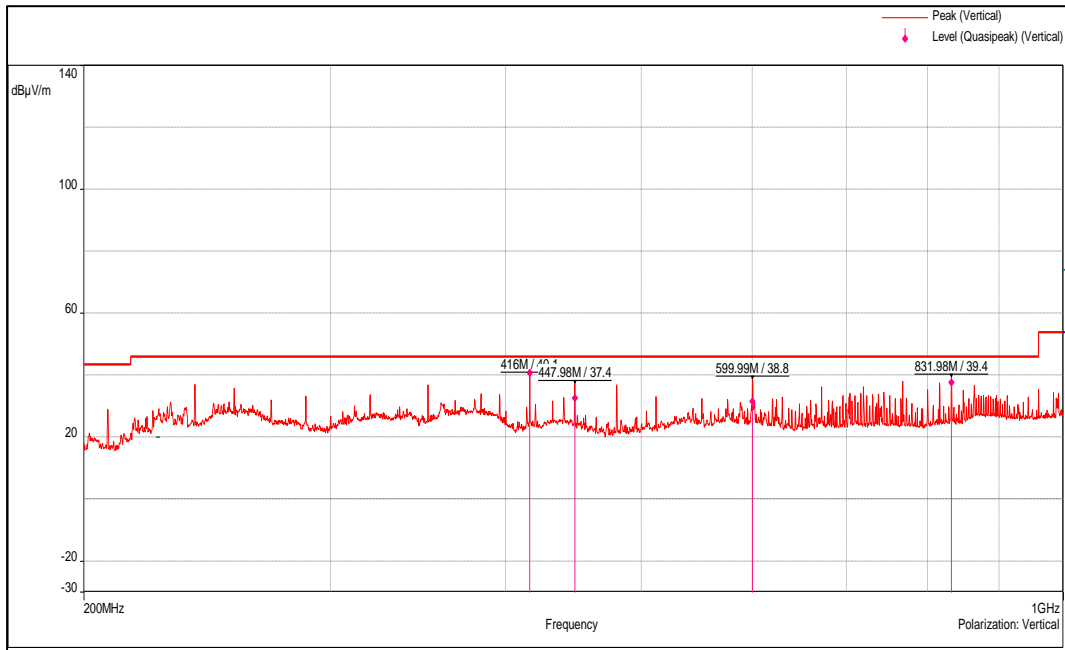

Channel Frequency 200MHz – 1GHz

Polarization Vertical

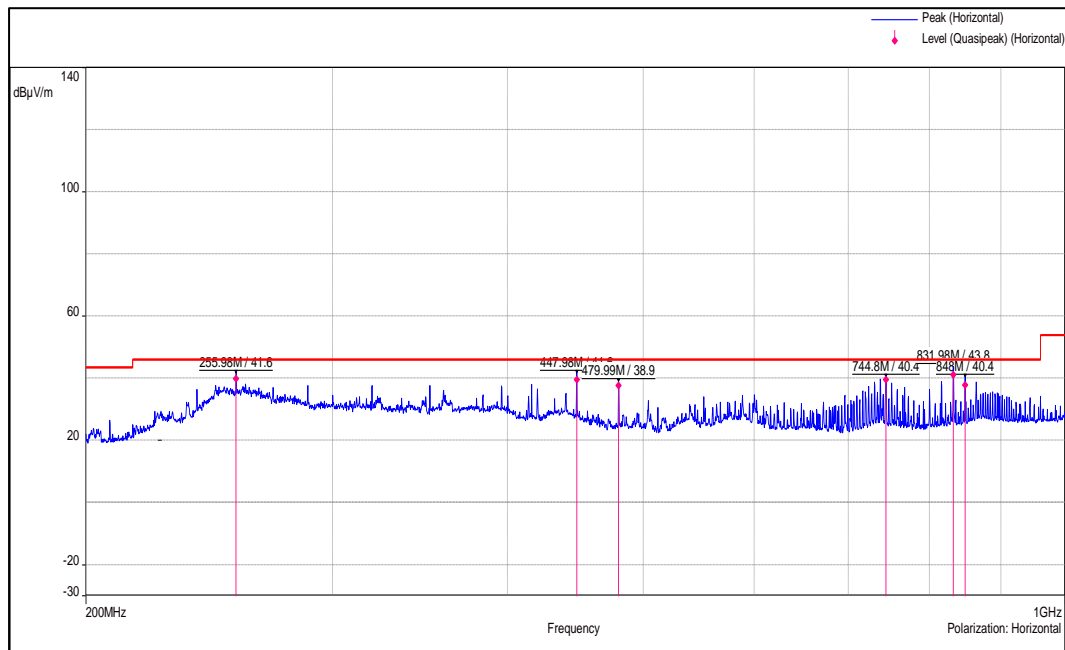

Channel Frequency 200MHz – 1GHz

Polarization Horizontal

Test results for the frequencies above 1GHz

Data Rate: 1Mbps

Channel Frequency (MHz)	Frequency (MHz)	Antenna Polarization	Emission (dBµV/m)	Limit (dBµV/m)	Margin (dB)
2402	2402(Pk)	Vertical	86.43	-	-
	2402(Av)		81.65	-	-
	2390(Pk)		38.20	74.00*	-35.80
	2390(Av)		24.68	54.00*	-29.32
	4804(Pk)		40.59	74.00	-33.41
	4804(Av)		29.08	54.00	-24.92
	7206(Pk)		47.32	74.00	-26.68
	7206(Av)		34.91	54.00	-19.09
	2402(Pk)	Horizontal	85.97	-	-
	2402(Av)		81.17	-	-
	2390(Pk)		37.77	74.00*	-36.23
	2390(Av)		24.51	54.00*	-29.49
	4804(Pk)		41.71	74.00	-32.29
	4804(Av)		28.85	54.00	-25.15
	7206(Pk)		46.73	74.00	-27.27
	7206(Av)		34.75	54.00	-19.25
2440	2440(Pk)	Vertical	86.15	-	-
	2440(Av)		81.42	-	-
	4880(Pk)		41.78	74.00	-32.22
	4880(Av)		29.21	54.00	-24.79
	7320(Pk)		47.37	74.00	-26.63
	7320(Av)		35.13	54.00	-18.87
	2440(Pk)	Horizontal	84.74	-	-
	2440(Av)		79.96	-	-
	4880(Pk)		41.76	74.00	-32.24
	4880(Av)		29.03	54.00	-24.97
	7320(Pk)		47.09	74.00	-26.91
	7320(Av)		35.05	54.00	-18.95
2480	2480(Pk)	Vertical	88.47	-	-
	2480(Av)		83.71	-	-
	2483.5(Pk)		40.56	74.00*	-33.44
	2483.5(Av)		25.61	54.00*	-28.39
	4960(Pk)		41.74	74.00	-32.26
	4960(Av)		30.34	54.00	-23.66
	7440(Pk)		47.84	74.00	-26.16
	7440(Av)		36.24	54.00	-17.76
	2480(Pk)	Horizontal	87.74	-	-
	2480(Av)		82.97	-	-
	2483.5(Pk)		40.21	74.00*	-33.79
	2483.5(Av)		25.75	54.00*	-28.25
	4960(Pk)		40.84	74.00	-33.16
	4960(Av)		29.13	54.00	-24.87
	7440(Pk)		47.17	74.00	-26.83
	7440(Av)		35.09	54.00	-18.91

* : Indicate restricted band of operation §15.205
Pk: Peak Detector; Av: Average Detector

Test Plots

Data Rate: 1Mbps

Channel Frequency 2480MHz

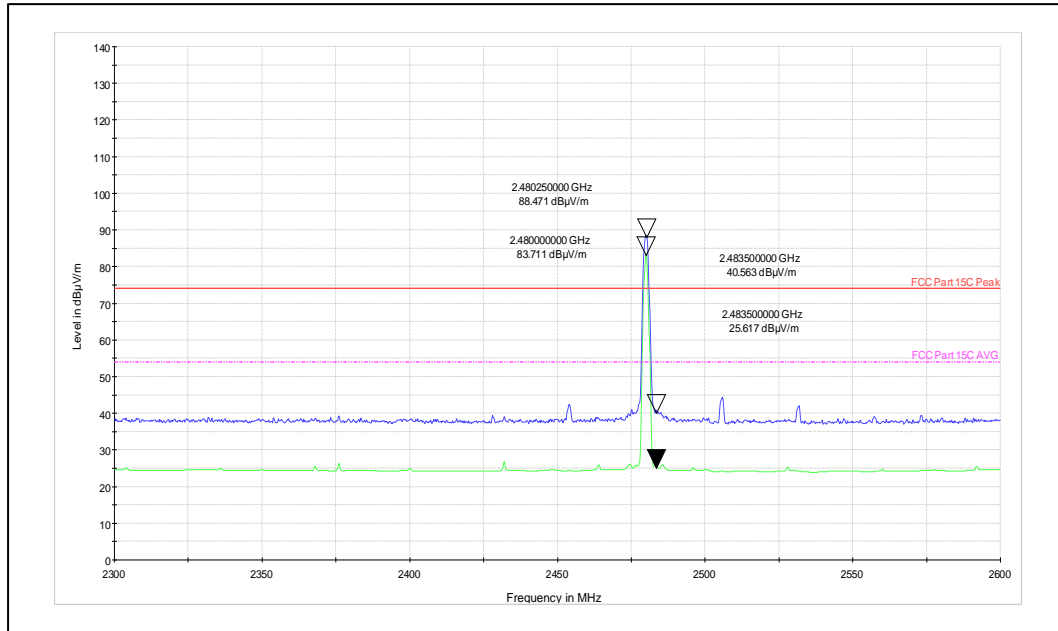

Channel Frequency: 2480MHz

Polarization: Vertical

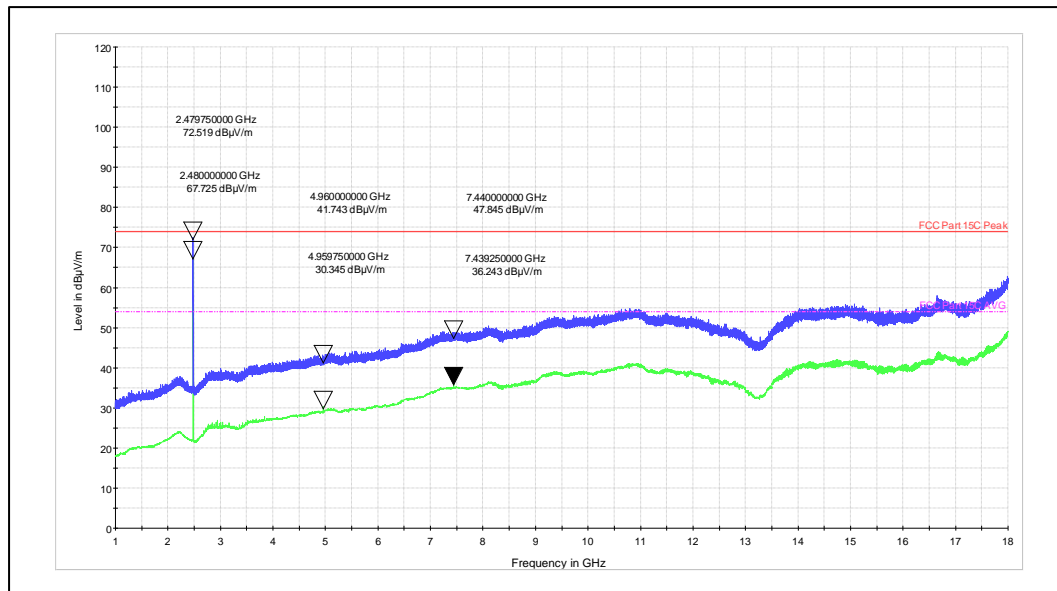

Channel Frequency: 1 GHz – 18 GHz

Polarization: Vertical

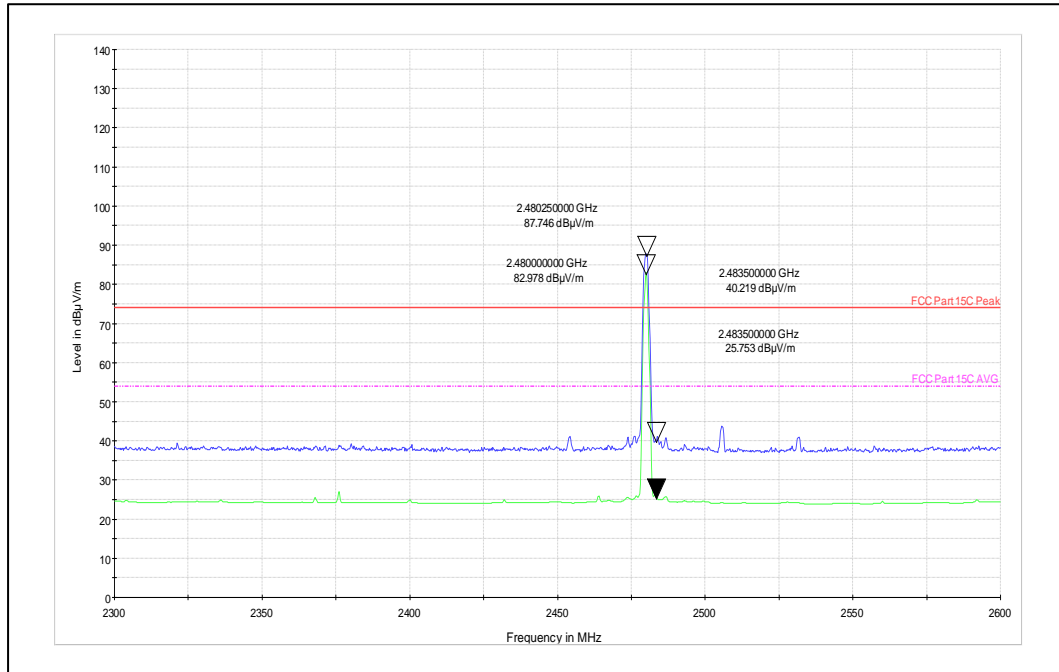

Channel Frequency: 2480MHz

Polarization: Horizontal

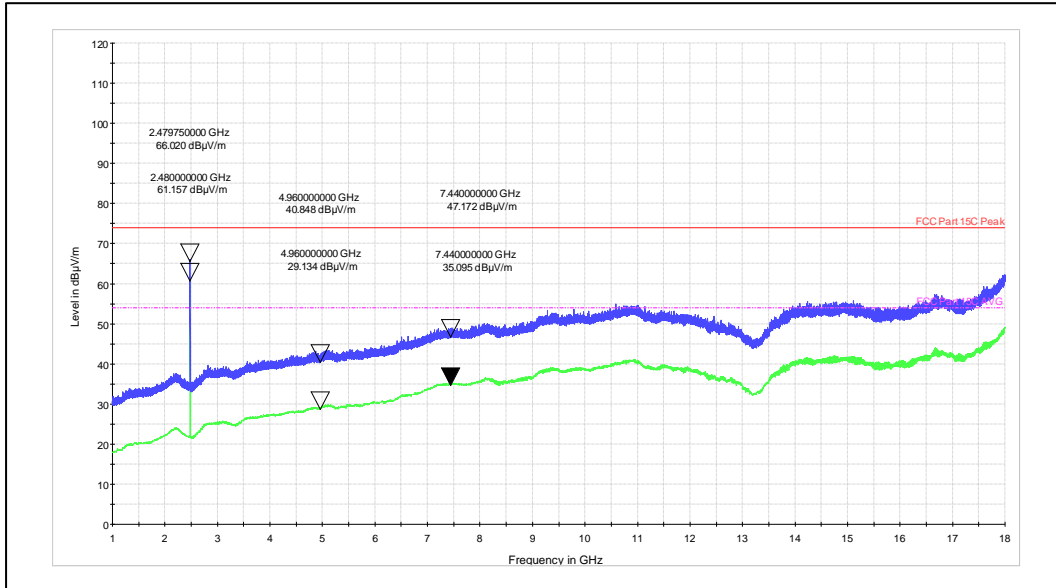

Channel Frequency: 1 GHz– 18 GHz

Polarization: Horizontal

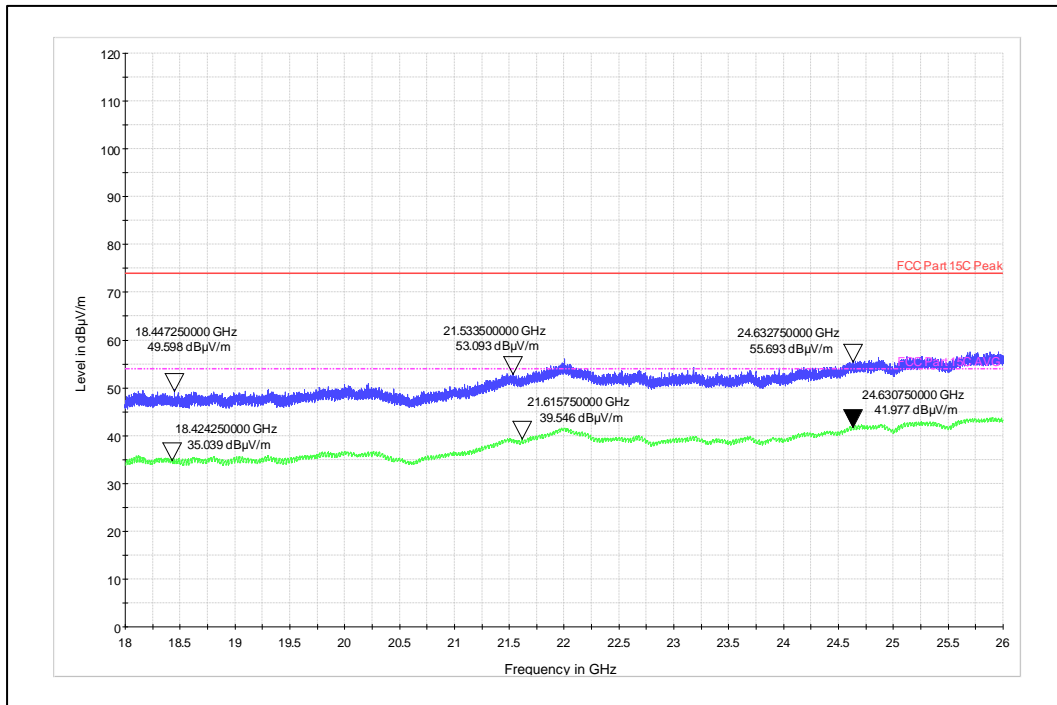

Channel Frequency: 18 - 26 GHz

Polarization: Vertical

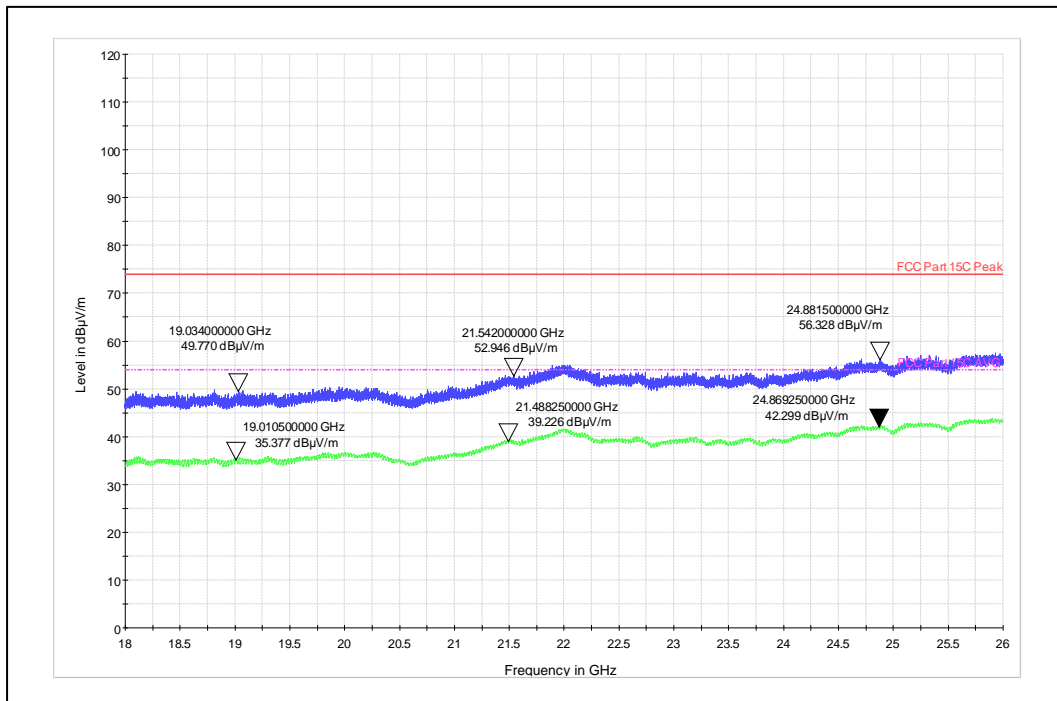

Channel Frequency: 18 - 26 GHz

Polarization: Horizontal

Prüfbericht - Nr.:
Test Report No.:

ULR-TC56882230000092F

Seite 46 von 53
Page 46 of 53

Simultaneous Operation:

Combination of Wi-Fi 2.4GHz & BLE

Channel Frequency (MHz)	Antenna Polarization	Measured Frequency (MHz)	Measured Emission (dBµV/m)	Limit (dBµV/m)	Margin (dB)
2402	Vertical	2402(Pk)	54.61	-	-
		2402(Av)	48.39	-	-
		2390(Pk)	37.15	74*	-36.85
		2390(Av)	24.31	54*	-29.69
		4804(Pk)	41.39	74	-32.61
		4804(Av)	29.14	54	-24.86
		7206(Pk)	47.95	74	-26.05
7206(Av)		35.33	54	-18.67	
2462		2462(Pk)	90.80	-	-
		2462(Av)	88.15	-	-
		2483.5(Pk)	40.30	74*	-33.70
		2483.5(Av)	28.24	54*	-25.76
		4924(Pk)	43.95	74	-30.05
		4924(Av)	35.46	54	-18.54
	7386(Pk)	46.78	74	-27.22	
7386(Av)	34.91	54	-19.09		
2402	Horizontal	2402(Pk)	56.21	-	-
		2402(Av)	50.27	-	-
		2390(Pk)	37.36	74*	-36.64
		2390(Av)	24.36	54*	-29.64
		4804(Pk)	41.22	74	-32.78
		4804(Av)	28.92	54	-25.08
		7206(Pk)	46.74	74	-27.26
7206(Av)		34.94	54	-19.06	
2462		2462(Pk)	90.24	-	-
		2462(Av)	87.63	-	-
		2483.5(Pk)	39.76	74*	-34.24
		2483.5(Av)	28.05	54*	-25.95
		4924(Pk)	43.07	74	-30.93
		4924(Av)	34.52	54	-19.48
	7386(Pk)	46.90	74	-27.10	
7386(Av)	34.78	54	-19.22		

* : Indicate restricted band of operation §15.205
Pk: Peak Detector; Av: Average Detector

Test Plots:

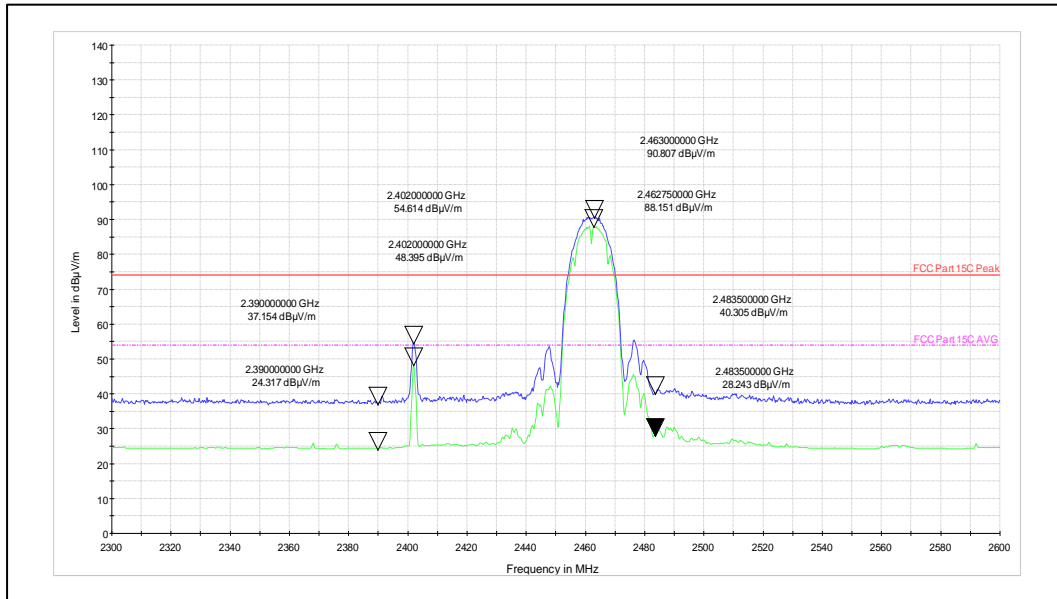

Channel Frequency: 2402MHz and 2462MHz

Polarization: Vertical

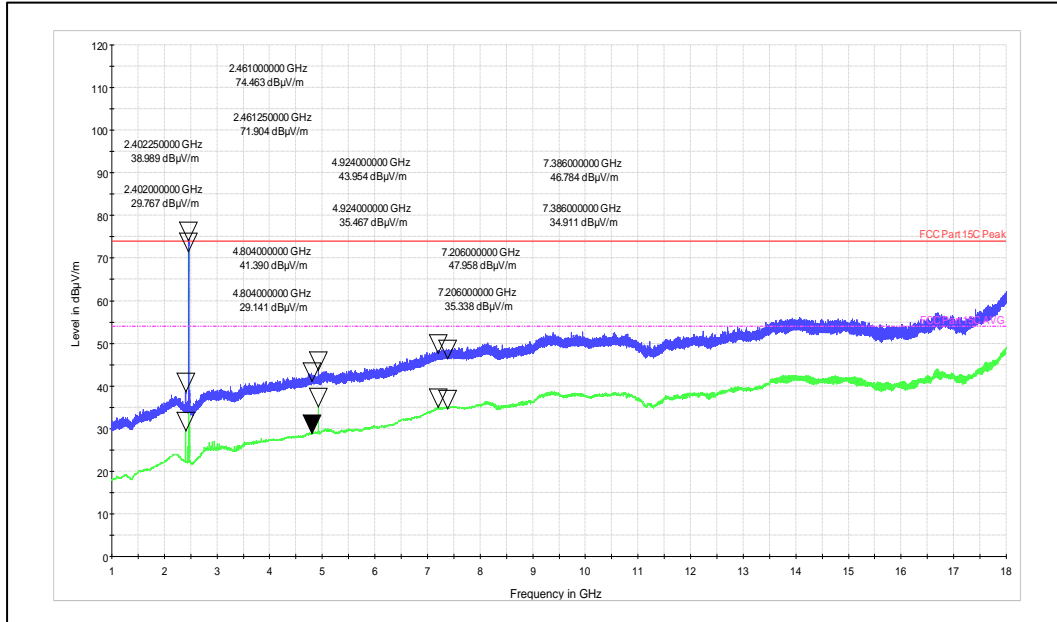

Channel Frequency: 1 GHz – 18 GHz

Polarization: Vertical

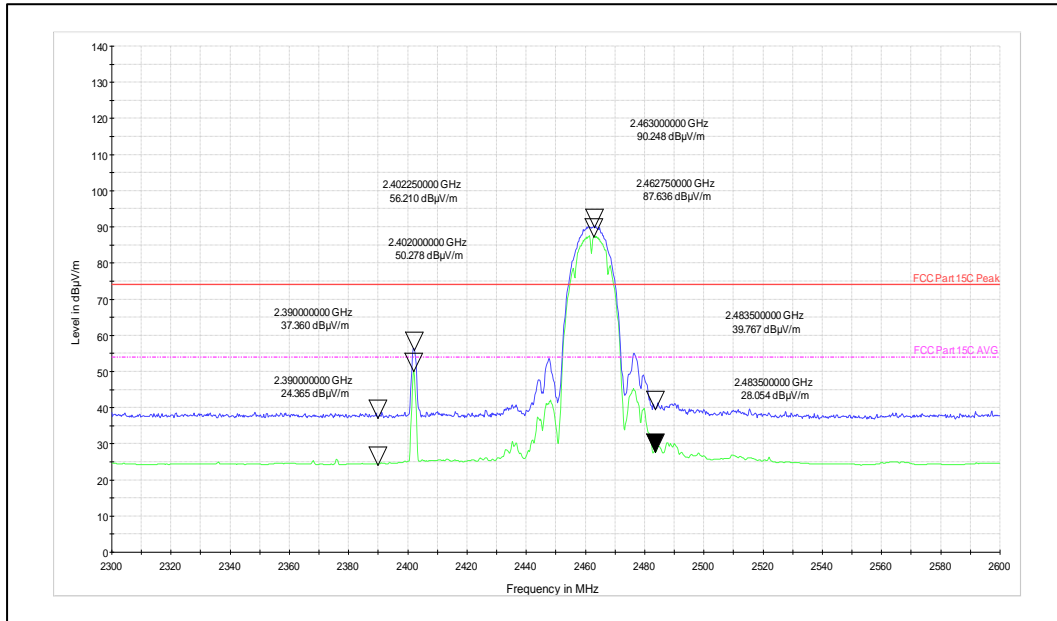

Channel Frequency: 2402MHz and 2462MHz

Polarization: Horizontal

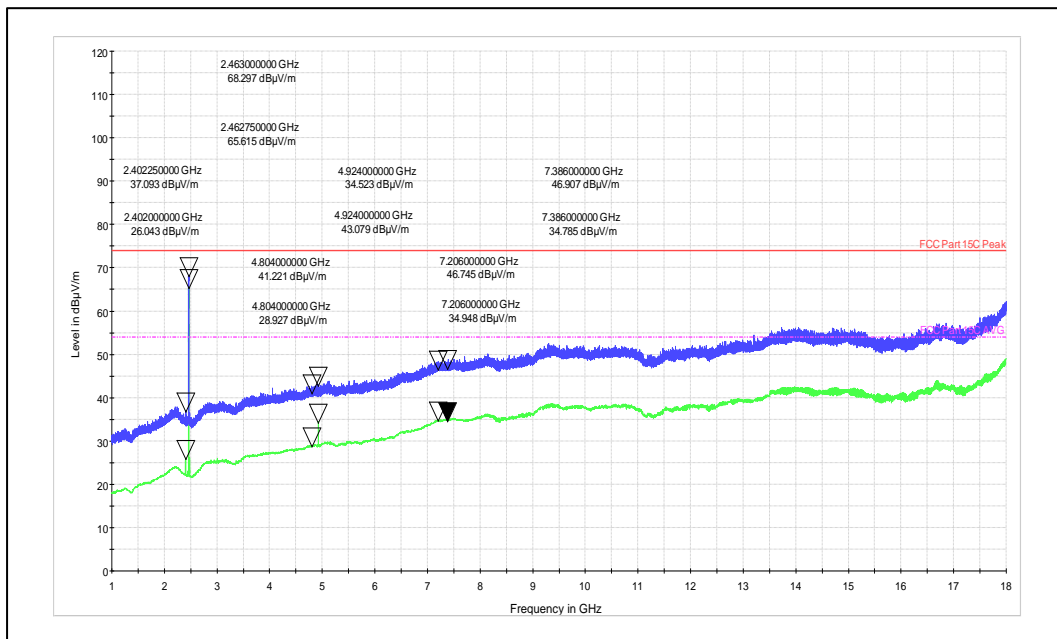

Channel Frequency: 1 GHz– 18 GHz

Polarization: Horizontal

Prüfbericht - Nr.:
Test Report No.:

ULR-TC568822300000092F

Seite 49 von 53
Page 49 of 53

9 Conducted Spurious Emission Test on AC Power Line

Result

Pass

Test Specification : FCC Part 15 Section 15.207
 Test Method : ANSI C 63.10-2013
 Testing Location : Screened room
 Measurement Bandwidth : 9kHz
 Frequency Range : 150kHz – 30MHz
 Supply Voltage : 110VAC,60Hz
 Test Method : Refer TEST METHODOLOGY

***Note: The product has tested with AC to DC adapter**

Limits of section 15.207

Frequency of emission (MHz)	Conducted limit (dBµV)	
	Quasi-peak (dBµV)	Average (dBµV)
0.15-0.5	66-56*	56-46*
0.5-5	56	46
5-30	60	50

* Decreases with the logarithm of the frequency

Test Conditions:

Normal Temperature = +24°C

Voltage = 110V AC and 60 Hz Supply

Humidity = 64%

Test result:

Power: 110V 60Hz_LINE

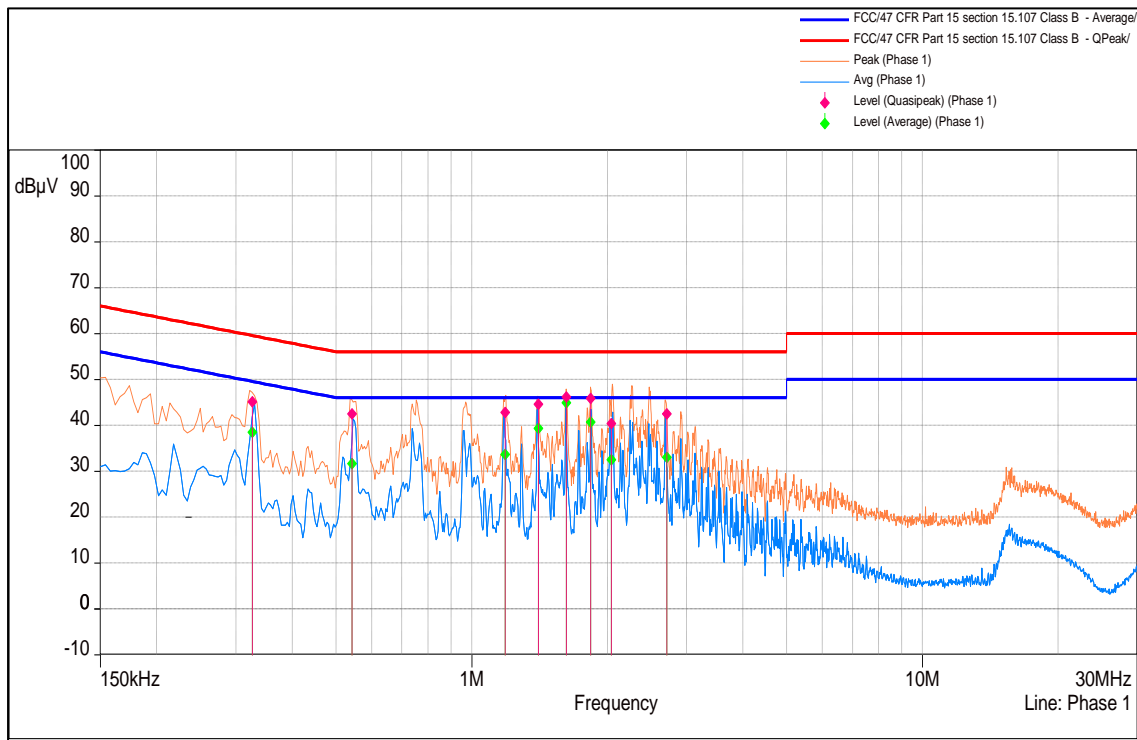

Line Graph

Quasipeak:-

Frequency (MHz)	Correction (dB)	Level (dBµV)	Limit (dBµV)	Margin (dB)	Comments
1.62065	19.57	46.17	56.00	-9.83	Pass
1.83395	19.57	45.89	56.00	-10.11	Pass
1.40470	19.58	44.60	56.00	-11.40	Pass
1.18700	19.58	42.90	56.00	-13.10	Pass
2.70485	19.57	42.56	56.00	-13.44	Pass
0.54060	19.54	42.53	56.00	-13.47	Pass
0.32460	19.46	45.17	59.55	-14.38	Pass
2.03820	19.57	40.48	56.00	-15.52	Pass

Prüfbericht - Nr.:
Test Report No.:

ULR-TC56882230000092F

Seite 51 von 53
Page 51 of 53

Average:-

Frequency (MHz)	Correction (dB)	Level (dBµV)	Limit (dBµV)	Margin (dB)	Comments
1.62065	19.57	44.99	46.00	-1.01	Pass
1.83395	19.57	40.79	46.00	-5.21	Pass
1.40470	19.58	39.39	46.00	-6.61	Pass
0.32460	19.46	38.50	49.55	-11.05	Pass
1.18700	19.58	33.66	46.00	-12.34	Pass
2.70485	19.57	33.05	46.00	-12.95	Pass
2.03820	19.57	32.51	46.00	-13.49	Pass
0.54060	19.54	31.68	46.00	-14.32	Pass

Line Table

Power: 110V60Hz_NEUTRAL

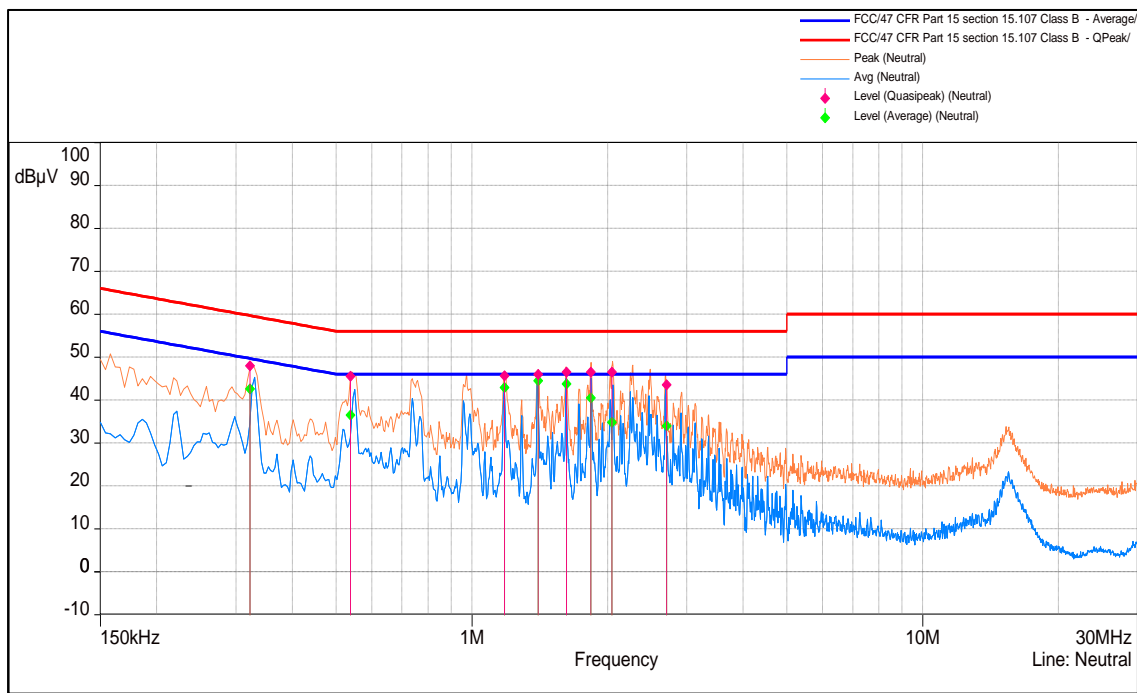

Neutral Graph

Prüfbericht - Nr.:
Test Report No.:

ULR-TC56882230000092F

Seite 52 von 53
Page 52 of 53

Quasipeak:-

Frequency (MHz)	Correction (dB)	Level (dB μ V)	Limit (dB μ V)	Margin (dB)	Comments
1.8335	19.57	46.58	56.00	-9.42	Pass
2.0477	19.57	46.52	56.00	-9.48	Pass
1.6225	19.58	46.49	56.00	-9.51	Pass
1.4021	19.58	45.98	56.00	-10.02	Pass
1.1802	19.59	45.67	56.00	-10.33	Pass
0.5388	19.54	45.59	56.00	-10.41	Pass
0.3237	19.46	48.05	59.66	-11.60	Pass
2.7004	19.57	43.60	56.00	-12.40	Pass

Average:-

Frequency (MHz)	Correction (dB)	Level (dB μ V)	Limit (dB μ V)	Margin (dB)	Comments
1.40205	19.58	44.50	46.00	-1.50	Pass
1.62250	19.58	43.79	46.00	-2.21	Pass
1.18020	19.59	42.99	46.00	-3.01	Pass
1.83350	19.57	40.55	46.00	-5.45	Pass
0.32370	19.46	42.59	49.66	-7.06	Pass
0.53875	19.54	36.51	46.00	-9.49	Pass
2.04765	19.57	34.83	46.00	-11.17	Pass
2.70035	19.57	34.00	46.00	-12.00	Pass

Neutral Table

Prüfbericht - Nr.:
Test Report No.:

ULR-TC568822300000092F

Seite 53 von 53
Page 53 of 53

10 LIST OF TABLES

Table 1: List of test and measurement instruments	6
Table 2: Instrument application Software versions	7
Table 3: Ratings and System Details as declared by Client*	8
Table 4: Measurement Uncertainty	9
Table 5: List of Wi-Fi center Frequencies	11
Table 6: List of BLE Center frequencies	11
Table 7: Transmitter limits for Radiated emission	19
Table 8: Transmitter limits for Radiated emission	38

*****END OF TEST REPORT*****