

东莞市金赞智能科技有限公司

DONGGUAN KIMCHEN INDUSTRY INTL LIMITED



DONGGUAN KIMCHEN INDUSTRY INTL LIMITED

SPECIFICATION FOR APPROVAL

CUSTOMER: _____
01.03.01031

CUST P/N: _____
01.03.01031

K C P/N: _____
MP-A2, 10uH, 50mm, Lead wire 10mm/ use for GF-06mini

PRODUCT : _____
19*19*45*46*0.08*105P*12TS*11MM

D E S E : _____
19 April 2023

D A T E : _____

VERSION : _____
A.0

ACCEPTANCE STAMP

PREPARED BY	MERCHANDISER	ENGINEER CHECKED BY	PRODUCTION CHECKDED BY	APPROVED BY
Yunfan Wang				

Address: No2 Xisha Road Shijie Guangdong 523290 Guangdong China

FileNo: KC-JZ-12-030

东莞市金赞智能科技有限公司

DONGGUAN KIMCHEN INDUSTRY INTL LIMITED

Specification

CUST P/N

01.03.01031

Des. ,

19*19*45*46*0.08*105P*12TS*11mm

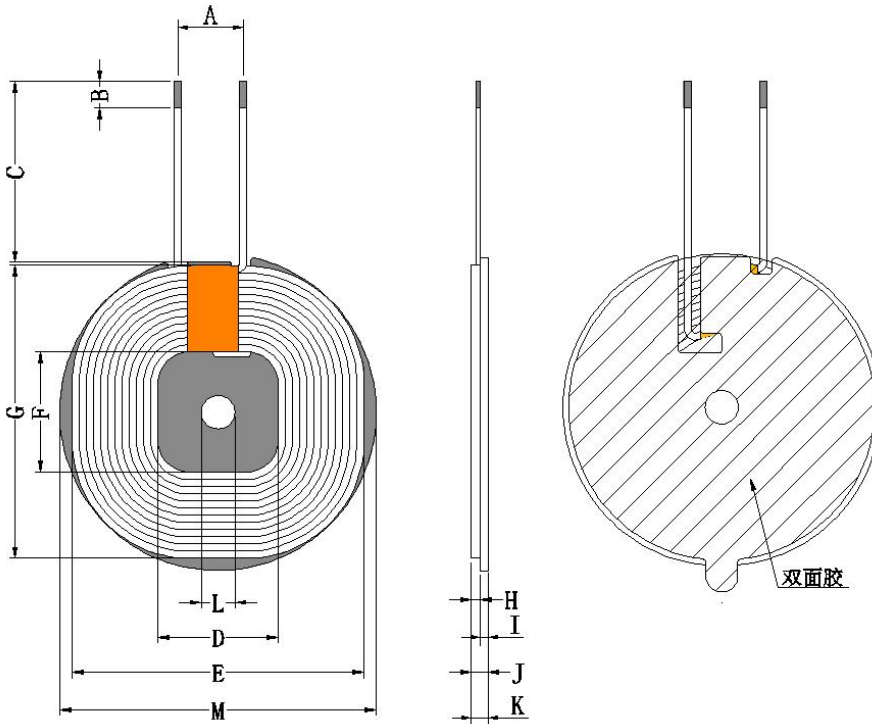

A	B	C	D	E	F	G
10±2	3.5±1.5	11±2	19±1	45±1	19±1	46±1
H	I	J	K	L	M	
1.25MAX	1±0.15	2.8MAX	3.1MAX	5.3±0.5	50±1	

Remark: J not including double side tape ,K as total thickness including double side tape

Turns	Wire Diameter	Winding Direction	Lead wire Intersect Yes/Not	Coil front/reverse Paste
12	0.08*105 strand USTC wire	clockwise	Not	reverse Paste

PREPARED BY

ENGINEER CHECKED BY

PRODUCTION CHECKED BY

Yunfan Wang

胡志军

王海燕

Address: No2 Xisha Road Shijie Guangdong 523290 Guangdong China

FileNo: KC-JZ-12-030

东莞市金赞智能科技有限公司

DONGGUAN KIMCHEN INDUSTRY INTL LIMITED

Specification	CUST P/N	01.03.01031
	Des. ,	19*19*45*46*0.08*105P*12TS*11mm

2. ELECTRICAL CHARACTERISTICS :

TEMPERATURE: 25 ± 10°C, RELATIVE HUMIDITY: 65 ± 10%

NO.	ITEM	TERMINAL	VALUE	TEST FREQUENCY	TEST EQUIPMENTS
1	IND	S-F	Coil: 5.8UH ± 10%	100kHz/V	LCZ METER 1062
2	IND	S-F	Coil+ferrite: 10.0UH ± 10%	100kHz/V	LCZ METER 1062
3	Q Factor	S-F	75MIN	100kHz/V	LCZ METER 1062
4	DCR	S-F	60m Ω MAX	1kHz/V	LCZ METER 1062

3. BILL OF MATERIALS :

NO.	Material name	Description	Material Code
1	Wire	0.08*105 Strand USTC Wire	SBX-2U-F-0011
2	Ferrite Core	G50*5.3*1.0H	GCP-T-0050
2	Double side tape (48.5*5.3*0.08H	SMJ-000018
3	Kapton tape	8mm	8mm
4	Tin rod	Lead-free SnCu	LZD-Snun-011
5			

PREPARED BY	ENGINEER CHECKED BY	PRODUCTION CHECKED BY
Yunfan Wang	胡志军	王海波

Address: No2 Xisha Road Shijie Guangdong 523290 Guangdong China

FileNo: KC-JZ-12-030