

# FCC RADIO TEST REPORT

## FCC ID: 2ATVU-U231AZZLE1

**Product:** U231AZZ-LE1

**Trade Mark:** N/A

**Model No.:** U231AZZ-LE1

**Family Model:** PDP460UUN01

**Report No.:** S20081701502003

**Issue Date:** 12 Oct. 2020

### Prepared for

Perfect Intelligent Technology Limited  
Flat 903 9/F New Lee Wah Centre, No. 88 ToKwaWan Road,  
ToKwaWan, Kowloon, Hong Kong

### Prepared by

Shenzhen NTEK Testing Technology Co., Ltd.  
1/F, Building E, Fenda Science Park Sanwei, Xixiang, Bao'an  
District Shenzhen, Guangdong, China  
Tel.: 400-800-6106, 0755-3699 5508  
Website: <http://www.ntek.org.cn>

TEST RESULT CERTIFICATION

Applicant's name : Perfect Intelligent Technology Limited
Address : Flat 903 9/F New Lee Wah Centre, No. 88 ToKwaWan Road, ToKwaWan, Kowloon, Hong Kong
Manufacturer's Name : I.A. TECHNOLOGY (DONG GUAN) COMPANY LTD.
Address : BUILDING A, NO.478 YOU YI ROAD, QIAO TOU TOWN, DONGGUAN, GUANGDONG PROVINCE, CHINA

Product description

Product name : U231AZZ-LE1
Model and/or type reference : U231AZZ-LE1
Family Model : PDP460UUN01

Standards : FCC Part15.407

Test procedure : ANSI C63.10-2013 and KDB 789033 D02 General UNII Test Procedures New Rules v02r01
FCC KDB 905462 D02 UNII DFS Compliance Procedures New Rules v02
FCC KDB 662911 D01 Multiple Transmitter Output v02r01
KDB 905462 D03 Client Without DFS New Rules v01r02

This device described above has been tested by NTEK, and the test results show that the equipment under test (EUT) is in compliance with the FCC requirements. And it is applicable only to the tested sample identified in the report.

This report shall not be reproduced except in full, without the written approval of NTEK, this document may be altered or revised by NTEK, personnel only, and shall be noted in the revision of the document.

Date of Test

Date (s) of performance of tests : 17 Sep. 2020 ~ 09 Oct. 2020

Date of Issue : 12 Oct, 2020

Test Result : Pass

Testing Engineer : [Signature: Allen Liu]
(Allen Liu)

Technical Manager : [Signature: Jason Chen]
(Jason Chen)

Authorized Signatory : [Signature: Alex Li]
(Alex Li)

**Table of Contents**

	<b>Page</b>
<b>1. SUMMARY OF TEST RESULTS</b>	<b>7</b>
1.1 FACILITIES AND ACCREDITATIONS	8
1.2 MEASUREMENT UNCERTAINTY	8
<b>1 . GENERAL INFORMATION</b>	<b>9</b>
1.1 GENERAL DESCRIPTION OF EUT	9
1.2 DESCRIPTION OF TEST MODES	11
1.3 BLOCK DIGRAM SHOWING THE CONFIGURATION OF SYSTEM TESTED	12
1.4 DESCRIPTION OF SUPPORT UNITS(CONDUCTED MODE)	13
1.5 EQUIPMENTS LIST FOR ALL TEST ITEMS	14
<b>2 . EMC EMISSION TEST</b>	<b>16</b>
2.1 CONDUCTED EMISSION MEASUREMENT	16
2.1.1 APPLICABLE STANDARD	16
2.1.2 CONFORMANCE LIMIT	16
2.1.3 TEST CONFIGURATION	16
2.1.4 TEST PROCEDURE	16
2.2 RADIATED EMISSION MEASUREMENT	25
2.2.1 APPLICABLE STANDARD	25
2.2.2 CONFORMANCE LIMIT	25
2.2.3 MEASURING INSTRUMENTS	25
2.2.4 TEST CONFIGURATION	26
2.2.5 TEST PROCEDURE	27
2.2.6 TEST RESULTS (9KHZ – 30 MHZ)	28
2.2.7 TEST RESULTS (30MHZ – 1GHZ)	29
2.2.8 TEST RESULTS (1GHZ-18GHZ)	37
2.2.10 TEST RESULTS (18GHZ-40GHZ)	41
<b>3 . POWER SPECTRAL DENSITY TEST</b>	<b>52</b>
3.1 APPLIED PROCEDURES / LIMIT	52
3.2 TEST PROCEDURE	53
3.3 DEVIATION FROM STANDARD	53
3.4 TEST SETUP	53
3.5 EUT OPERATION CONDITIONS	53
3.6 TEST RESULTS	54
<b>4 . 26DB &amp; 99% EMISSION BANDWIDTH</b>	<b>55</b>
4.1 APPLIED PROCEDURES / LIMIT	55
4.2 TEST PROCEDURE	55
4.3 EUT OPERATION CONDITIONS	56
4.4 TEST RESULTS	56
<b>5 . MINIMUM 6 DB BANDWIDTH</b>	<b>57</b>

**Table of Contents**

	<b>Page</b>
5.1 APPLIED PROCEDURES / LIMIT	57
5.2 TEST PROCEDURE	57
5.3 DEVIATION FROM STANDARD	57
5.4 TEST SETUP	57
5.5 EUT OPERATION CONDITIONS	57
5.6 TEST RESULTS	58
<b>6 . MAXIMUM CONDUCTED OUTPUT POWER</b>	<b>59</b>
6.1 PPLIED PROCEDURES / LIMIT	59
6.2 TEST RESULTS	61
<b>7 . OUT OF BAND EMISSIONS</b>	<b>62</b>
7.1 APPLICABLE STANDARD	62
7.2 TEST PROCEDURE	62
7.3 DEVIATION FROM STANDARD	62
7.4 TEST SETUP	62
7.5 EUT OPERATION CONDITIONS	63
7.6 TEST RESULTS	64
<b>8. FREQUENCY STABILITY MEASUREMENT</b>	<b>65</b>
8.1 LIMIT	65
8.2 TEST PROCEDURES	65
8.3 TEST SETUP LAYOUT	65
8.4 EUT OPERATION DURING TEST	65
8.5 TEST RESULTS	66
<b>9. DYNAMIC FREQUENCY SELECTION(DFS)</b>	<b>78</b>
9.1 APPLICABILITY OF DFS REQUIREMENTS	78
9.2 INTERFERENCE THRESHOLD VALUES, MASTER OR CLIENT INCORPORATING IN-SERVICE MONITORING	78
9.3 DFS RESPONSE REQUIREMENT VALUES	79
9.4 SHORT PULSE RADAR TEST WAVEFORMS	79
9.5 CALIBRATION SETUP AND DFS TEST RESULTS	80
9.6 CONDUCTED CALIBRATION SETUP	80
9.7 RADAR WAVEFORM CALIBRATION RESULT	81
9.8 IN-SERVICE MONITORING: CHANNEL MOVE TIME, CHANNEL CLOSING TRANSMISSION TIME AND NON-OCCUPANCY PERIOD	82
9.9 RESULT OF CHANNEL MOVE TIME, CHANNEL CLOSING TRANSMISSION TIME AND NON-OCCUPANCY PERIOD FOR CLIENT BEACON TEST	83
<b>10. ANTENNA REQUIREMENT</b>	<b>84</b>

**Table of Contents**

	<b>Page</b>
<b>10.1 STANDARD REQUIREMENT</b>	<b>84</b>
<b>10.2 EUT ANTENNA</b>	<b>84</b>



## 1. SUMMARY OF TEST RESULTS

Test procedures according to the technical standards:

FCC Part15 (15.407) , Subpart E			
Standard Section	Test Item	Judgment	Remark
15.207	AC Power Line Conducted Emissions	PASS	
15.209(a), 15.407 (b)(1) 15.407 (b)(2) 15.407 (b)(3) 15.407 (b)(4) 15.407 (b)(6)	Spurious Radiated Emissions	PASS	
15.407 (a)	26 dB and 99% Emission Bandwidth	PASS	
15.407(e)	Minimum 6 dB bandwidth	PASS	
15.407 (a)	Maximum Conducted Output Power	PASS	
15.407 (b)(1) 15.407 (b)(2) 15.407 (b)(3) 15.407 (b)(4)	Band Edge	PASS	
15.407 (a)	Power Spectral Density	PASS	
15.407(b)	Spurious Emissions at Antenna Terminals	PASS	
15.407(g)	Frequency Stability Measurement	PASS	
15.407(h)	Dynamic Frequency Selection(DFS)	PASS	
15.203	Antenna Requirement	PASS	

**NOTE:**

- (1) "N/A" denotes test is not applicable in this Test Report
- (2) This device operates with a duty cycle greater than 99%

## 1.1 FACILITIES AND ACCREDITATIONS

### FACILITIES

All measurement facilities used to collect the measurement data are located at  
1/F, Building E, Fenda Science Park Sanwei, Xixiang, Bao'an District  
Shenzhen, Guangdong, China

The sites are constructed in conformance with the requirements of ANSI C63.7, ANSI C63.10 and CISPR Publication 22.

### LABORATORY ACCREDITATIONS AND LISTINGS

#### Site Description

CNAS-Lab. : The Laboratory has been assessed and proved to be in compliance with  
CNAS-CL01:2006 (identical to ISO/IEC 17025:2005)  
The Certificate Registration Number is L5516.

IC-Registration : The Certificate Registration Number is 9270A.  
CAB identifier:CN0074

FCC- Accredited : Test Firm Registration Number: 463705.  
Designation Number: CN1184

A2LA-Lab. : The Certificate Registration Number is 4298.01  
This laboratory is accredited in accordance with the recognized  
International Standard ISO/IEC 17025:2005 General requirements for the  
competence of testing and calibration laboratories.  
This accreditation demonstrates technical competence for a defined  
scope and the operation of a laboratory quality management system  
(refer to joint ISO-ILAC-IAF Communiqué dated 8 January 2009).

Name of Firm : Shenzhen NTEK Testing Technology Co., Ltd.

Site Location : 1/F, Building E, Fenda Science Park Sanwei, Xixiang, Bao'an District  
Shenzhen, Guangdong, China

## 1.2 MEASUREMENT UNCERTAINTY

The reported uncertainty of measurement  $y \pm U$ , where expanded uncertainty  $U$  is based on a standard uncertainty multiplied by a coverage factor of  $k=2$ , providing a level of confidence of approximately 95 %.

No.	Item	Uncertainty
1	Conducted Emission Test	$\pm 2.80\text{dB}$
2	RF power, conducted	$\pm 0.16\text{dB}$
3	Spurious emissions, conducted	$\pm 0.21\text{dB}$
4	All emissions, radiated(30MHz~1GHz)	$\pm 2.64\text{dB}$
5	All emissions, radiated(1GHz~6GHz)	$\pm 2.40\text{dB}$
6	All emissions, radiated(> 6GHz)	$\pm 2.52\text{dB}$
7	Temperature	$\pm 0.5^\circ\text{C}$
8	Humidity	$\pm 2\%$



**1. GENERAL INFORMATION**  
**1.1 GENERAL DESCRIPTION OF EUT**

Equipment	U231AZZ-LE1														
Trade Mark	N/A														
Model Name	U231AZZ-LE1														
Family Model	PDP460UUN01														
Model Difference	All models are the same circuit and RF module, except the model name.														
FCC ID	2ATVU-U231AZZLE1														
Product Description	<table border="1"> <tr> <td>Mode Supported</td> <td> <input checked="" type="checkbox"/>802.11a  <input checked="" type="checkbox"/>802.11n(HT20)  <input checked="" type="checkbox"/>802.11n(HT40)  <input checked="" type="checkbox"/>802.11ac(HT20)  <input checked="" type="checkbox"/>802.11ac(HT40)  <input checked="" type="checkbox"/>802.11ac(HT80)                 </td> </tr> <tr> <td>Data Rate</td> <td>                     802.11a: 6,9,12,18,24,36,48,54Mbps;                      802.11n(HT20/HT40):MCS0-MCS15;                      802.11ac(VHT20): NSS1, MCS0-MCS8                      802.11ac(VHT40/VHT80):NSS1, MCS0-MCS9                 </td> </tr> <tr> <td>Modulation</td> <td>OFDM with BPSK/QPSK/16QAM/64QAM</td> </tr> <tr> <td>Operating Frequency Range</td> <td> <input checked="" type="checkbox"/> U-NII-1: 5150 MHz ~5250MHz  <input checked="" type="checkbox"/> U-NII-2A: 5250MHz~5350MHz  <input checked="" type="checkbox"/> U-NII-2C: 5470MHz~5725MHz  <input checked="" type="checkbox"/> U-NII-3: 5725 MHz ~5850 MHz                 </td> </tr> <tr> <td>Function:</td> <td> <input type="checkbox"/>Outdoor AP <input type="checkbox"/>Indoor AP <input type="checkbox"/>Fixed P2P  <input checked="" type="checkbox"/>Client                 </td> </tr> <tr> <td>Antenna Type</td> <td>FPCB antenna</td> </tr> <tr> <td>Antenna Gain</td> <td>4.99dBi</td> </tr> </table>	Mode Supported	<input checked="" type="checkbox"/> 802.11a <input checked="" type="checkbox"/> 802.11n(HT20) <input checked="" type="checkbox"/> 802.11n(HT40) <input checked="" type="checkbox"/> 802.11ac(HT20) <input checked="" type="checkbox"/> 802.11ac(HT40) <input checked="" type="checkbox"/> 802.11ac(HT80)	Data Rate	802.11a: 6,9,12,18,24,36,48,54Mbps; 802.11n(HT20/HT40):MCS0-MCS15; 802.11ac(VHT20): NSS1, MCS0-MCS8 802.11ac(VHT40/VHT80):NSS1, MCS0-MCS9	Modulation	OFDM with BPSK/QPSK/16QAM/64QAM	Operating Frequency Range	<input checked="" type="checkbox"/> U-NII-1: 5150 MHz ~5250MHz <input checked="" type="checkbox"/> U-NII-2A: 5250MHz~5350MHz <input checked="" type="checkbox"/> U-NII-2C: 5470MHz~5725MHz <input checked="" type="checkbox"/> U-NII-3: 5725 MHz ~5850 MHz	Function:	<input type="checkbox"/> Outdoor AP <input type="checkbox"/> Indoor AP <input type="checkbox"/> Fixed P2P <input checked="" type="checkbox"/> Client	Antenna Type	FPCB antenna	Antenna Gain	4.99dBi
	Mode Supported	<input checked="" type="checkbox"/> 802.11a <input checked="" type="checkbox"/> 802.11n(HT20) <input checked="" type="checkbox"/> 802.11n(HT40) <input checked="" type="checkbox"/> 802.11ac(HT20) <input checked="" type="checkbox"/> 802.11ac(HT40) <input checked="" type="checkbox"/> 802.11ac(HT80)													
	Data Rate	802.11a: 6,9,12,18,24,36,48,54Mbps; 802.11n(HT20/HT40):MCS0-MCS15; 802.11ac(VHT20): NSS1, MCS0-MCS8 802.11ac(VHT40/VHT80):NSS1, MCS0-MCS9													
	Modulation	OFDM with BPSK/QPSK/16QAM/64QAM													
	Operating Frequency Range	<input checked="" type="checkbox"/> U-NII-1: 5150 MHz ~5250MHz <input checked="" type="checkbox"/> U-NII-2A: 5250MHz~5350MHz <input checked="" type="checkbox"/> U-NII-2C: 5470MHz~5725MHz <input checked="" type="checkbox"/> U-NII-3: 5725 MHz ~5850 MHz													
	Function:	<input type="checkbox"/> Outdoor AP <input type="checkbox"/> Indoor AP <input type="checkbox"/> Fixed P2P <input checked="" type="checkbox"/> Client													
	Antenna Type	FPCB antenna													
	Antenna Gain	4.99dBi													
	Based on the application, features, or specification exhibited in User's Manual, More details of EUT technical specification, please refer to the User's Manual.														
	Ratings	DC 12V from Adapter													
Adapter	<input checked="" type="checkbox"/> Adapter 1 supply: Model: MYX-1202000CP Input: 100-240V~50/60Hz 0.8A max Output: 12V--2.0A														
Battery	N/A														
Connecting I/O Port(s)	Please refer to the User's Manual														
Series No.	PDI460NN09240006														
HW Version	V2														
SW Version	20.9.18														

Note:

1. For a more detailed features description, please refer to the manufacturer's specifications or the User's Manual.
2. Frequency and Channel list:

Band	20MHz		40MHz		80MHz	
	Channel	Frequency	Channel	Frequency	Channel	Frequency
U-NII-1	36	5180 MHz	38	5190 MHz	42	5210 MHz
	40	5200 MHz	46	5230 MHz	-	-
	44	5220 MHz				
	48	5240 MHz				
U-NII-2A	52	5260 MHz	54	5270 MHz	58	5290 MHz
	56	5280 MHz	62	5310 MHz		
	60	5300 MHz				
	64	5320 MHz				
U-NII-2C	100	5500 MHz	102	5510 MHz	106	5530 MHz
	104	5520 MHz	110	5550 MHz	122	5610 MHz
	108	5540 MHz	118	5590 MHz		
	112	5560 MHz	126	5630 MHz		
	116	5580 MHz	134	5670 MHz		
	120	5600 MHz				
	124	5620 MHz				
	128	5640 MHz				
	132	5660 MHz				
	136	5680 MHz				
U-NII-3	149	5745 MHz	151	5755 MHz	155	5775 MHz
	153	5765 MHz	159	5795 MHz		
	157	5785 MHz				
	161	5805 MHz				
	165	5825 MHz				

## 1.2 DESCRIPTION OF TEST MODES

To investigate the maximum EMI emission characteristics generates from EUT, the test system was pre-scanning tested base on the consideration of following EUT operation mode or test configuration mode which possible have effect on EMI emission level. Each of these EUT operation mode(s) or test configuration mode(s) mentioned above was evaluated respectively.

Pretest Mode	Description
Mode 1	Normal Link Mode
Mode 2	802.11a / n/ ac 20 CH36/ CH40/ CH48/CH52/CH56/CH64/CH100/CH120/CH140/CH149/ CH157/CH165
Mode 3	802.11n40/ac40 CH38/CH46/CH54/CH62/CH102/CH118/CH134/CH151/ CH159
Mode 4	802.11ac80 CH42/CH58/CH106/CH122/CH155

For Radiated Emission	
Final Test Mode	Description
Mode 1	Normal Link Mode
Mode 2	802.11a / n/ ac 20 CH36/ CH40/ CH48/CH52/CH56/CH64/CH100/CH120/CH140/CH149/ CH157/CH165
Mode 3	802.11n40/ac40 CH38/CH46/CH54/CH62/CH102/CH118/CH134/CH151/ CH159
Mode 4	802.11ac80 CH42/CH58/CH106/CH122/CH155

Note:

- (1) The measurements are performed at the highest, middle, lowest available channels.
- (2) The measurements are performed at all Bit Rate of Transmitter, the worst data was reported

**1.3 BLOCK DIGRAM SHOWING THE CONFIGURATION OF SYSTEM TESTED**

For AC Conducted Emission Mode

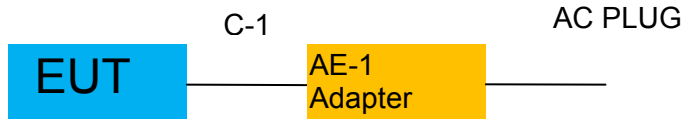

For Radiated Test Cases

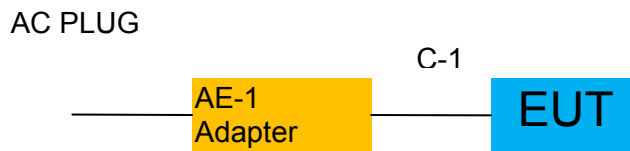

For Conducted Test Cases

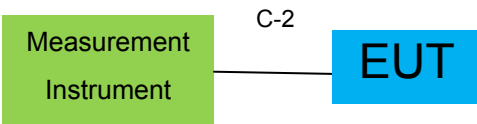

Note: 1. The temporary antenna connector is soldered on the PCB board in order to perform conducted tests and this temporary antenna connector is listed in the equipment list.

**1.4 DESCRIPTION OF SUPPORT UNITS(CONDUCTED MODE)**

The EUT has been tested as an independent unit together with other necessary accessories or support units. The following support units or accessories were used to form a representative test configuration during the tests.

Item	Equipment	Brand	Model/Type No.	Series No.	Note
AE-1	Adapter	N/A	MYX-1202000CP	N/A	Peripherals

Item	Cable Type	Shielded Type	Ferrite Core	Length	Note
C-1	Power Cable	NO	NO	1.2m	
C-2	RF Cable	YES	NO	0.1m	

Note:

- (1) The support equipment was authorized by Declaration of Confirmation.
- (2) For detachable type I/O cable should be specified the length in cm in 『Length』 column.
- (3) During the battery power test, the battery is fully charged.

### 1.5 EQUIPMENTS LIST FOR ALL TEST ITEMS

Radiation& Conducted Test equipment

Item	Kind of Equipment	Manufacturer	Type No.	Serial No.	Last calibration	Calibrated until	Calibration period
1	Spectrum Analyzer	Agilent	E4407B	MY45108040	2020.05.11	2021.05.10	1 year
2	Spectrum Analyzer	Agilent	N9020A	MY49100060	2020.07.13	2021.07.12	1 year
3	Spectrum Analyzer	R&S	FSV40	101417	2020.08.07	2021.08.06	1 year
4	Test Receiver	R&S	ESPI7	101318	2020.05.11	2021.05.10	1 year
5	Bilog Antenna	TESEQ	CBL6111D	31216	2020.04.11	2021.04.10	1 year
6	50Ω Coaxial Switch	Anritsu	MP59B	6200983705	2020.05.11	2023.05.10	3 year
7	Horn Antenna	EM	EM-AH-10180	2011071402	2020.04.11	2021.04.10	1 year
8	Amplifier	EMC	EMC051835SE	980246	2020.07.13	2021.07.12	1 year
9	Active Loop Antenna	SCHWARZBECK	FMZB 1519B	055	2019.12.11	2020.12.10	1 year
10	Power Meter	DARE	RPR3006W	15100041SN084	2020.07.13	2021.07.12	1 year
11	USB RF Power Sensor	DARE	RPR3006W	15100041SN084	2020.07.13	2021.07.12	1 year
12	Test Cable (9KHz-30MHz)	N/A	R-01	N/A	2019.08.06	2022.08.05	3 year
13	Test Cable (30MHz-1GHz)	N/A	R-02	N/A	2020.07.13	2021.07.12	1 year
14	High Test Cable(1G-40GHz)	N/A	R-03	N/A	2019.06.28	2022.06.27	3 year
15	High Test Cable(1G-40GHz)	N/A	R-04	N/A	2020.04.11	2021.04.10	3 year
16	Filter	TRILTHIC	2400MHz	29	2020.07.13	2021.07.12	3 year
17	temporary antenna connector (Note)	NTS	R001	N/A	N/A	N/A	N/A
18	Low Noise Amplifier	B&Z	BZ-P540-550850-452727	16476-11729	2020.04.15	2021.04.14	1 year
19	Broadband Horn Antenna	SCHWARZBECK	BBHA 9170	803	2019.12.11	2020.12.10	1 year
20	Thermal Chamber	Ten Billion	TTC-B3C	TBN-960502	2020.05.11	2021.05.10	1 year

Note:

We will use the temporary antenna connector (soldered on the PCB board) When conducted test  
And this temporary antenna connector is listed within the instrument list

AC Conduction Test equipment

Item	Kind of Equipment	Manufacturer	Type No.	Serial No.	Last calibration	Calibrated until	Calibration period
1	Test Receiver	R&S	ESCI	101160	2020.05.11	2021.05.10	1 year
2	LISN	R&S	ENV216	101313	2020.04.11	2021.04.10	1 year
3	LISN	SCHWARZBECK	NNLK 8129	8129245	2020.05.11	2021.05.10	1 year
4	50Ω Coaxial Switch	ANRITSU CORP	MP59B	6200983704	2020.05.11	2023.05.10	3 year
5	Test Cable (9KHz-30MHz)	N/A	C01	N/A	2020.05.11	2023.05.10	3 year
6	Test Cable (9KHz-30MHz)	N/A	C02	N/A	2020.05.11	2023.05.10	3 year
7	Test Cable (9KHz-30MHz)	N/A	C03	N/A	2020.05.11	2021.05.10	1 year

Note: Each piece of equipment is scheduled for calibration once a year except the Test Cable& Aux Equipment which is scheduled for calibration every 3 years.

## 2. EMC EMISSION TEST

### 2.1 CONDUCTED EMISSION MEASUREMENT

#### 2.1.1 APPLICABLE STANDARD

According to FCC Part 15.207(a)

#### 2.1.2 CONFORMANCE LIMIT

Frequency(MHz)	Conducted Emission Limit	
	Quasi-peak	Average
0.15-0.5	66-56*	56-46*
0.5-5.0	56	46
5.0-30.0	60	50

Note: 1. \*Decreases with the logarithm of the frequency  
 2. The lower limit shall apply at the transition frequencies  
 3. The limit decreases in line with the logarithm of the frequency in the range of 0.15 to 0.50MHz.

#### 2.1.3 TEST CONFIGURATION

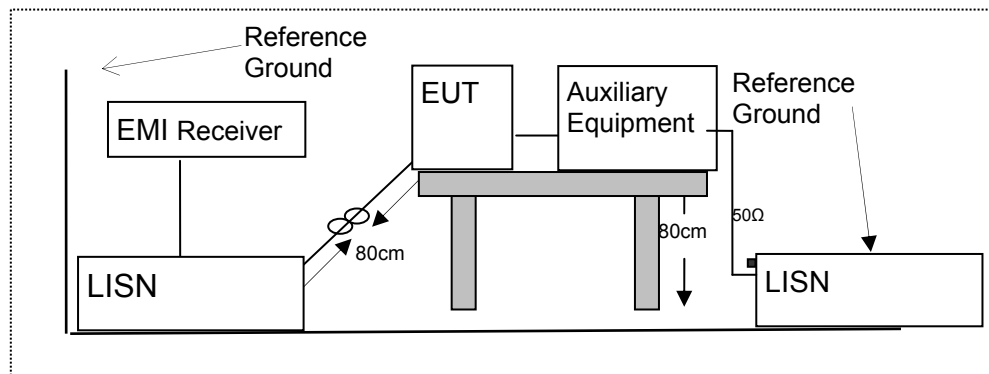

#### 2.1.4 TEST PROCEDURE

According to the requirements in Section 13.1.4.1 of ANSI C63.10-2013 Conducted emissions the EUT measured in the frequency range between 0.15 MHz and 30 MHz using CISPR Quasi-Peak and average detector mode.

1. The EUT was placed 0.4 meter from the conducting wall of the shielding room.
2. The EUT was placed on a table which is 0.8m above ground plane.
3. Connect EUT to the power mains through a line impedance stabilization network (LISN). All other support equipments powered from additional LISN(s). The LISN provide 50 Ohm/ 50uH of coupling impedance for the measuring instrument.
4. Interconnecting cables that hang closer than 40 cm to the ground plane shall be folded back and forth in the center forming a bundle 30 to 40cm long.
5. I/O cables that are not connected to a peripheral shall be bundled in the center. The end of the cable may be terminated, if required, using the correct terminating impedance. The overall length shall not exceed 1 m.
6. LISN at least 80 cm from nearest part of EUT chassis.
7. The frequency range from 150KHz to 30MHz was searched.
8. Set the test-receiver system to Peak Detect Function and specified bandwidth(IF bandwidth=9KHz) with Maximum Hold Mode
9. For the actual test configuration, please refer to the related Item –EUT Test Photos.



EUT :	U231AZZ-LE1	Model Name. :	U231AZZ-LE1
Temperature :	26 °C	Relative Humidity :	56%
Pressure :	1010hPa	Phase :	L
Test Voltage :	DC 12V from Adapter AC 120V/60Hz	Test Mode :	Mode 1(5.2G)

Frequency (MHz)	Reading Level (dBμV)	Correct Factor (dB)	Measurement (dBμV)	Limits (dBμV)	Margin (dB)	Remark
0.3020	38.64	9.54	48.18	60.19	-12.01	QP
0.3020	34.18	9.54	43.72	50.19	-6.47	AVG
0.5060	38.17	9.55	47.72	56.00	-8.28	QP
0.5060	27.57	9.55	37.12	46.00	-8.88	AVG
0.7100	37.67	9.55	47.22	56.00	-8.78	QP
0.7100	31.53	9.55	41.08	46.00	-4.92	AVG
0.9180	37.51	9.56	47.07	56.00	-8.93	QP
0.9180	28.49	9.56	38.05	46.00	-7.95	AVG
1.3140	36.88	9.56	46.44	56.00	-9.56	QP
1.3140	26.80	9.56	36.36	46.00	-9.64	AVG
4.7980	36.48	9.62	46.10	56.00	-9.90	QP
4.7980	29.71	9.62	39.33	46.00	-6.67	AVG

Remark:

1. All readings are Quasi-Peak and Average values.
2. Factor = Insertion Loss + Cable Loss.

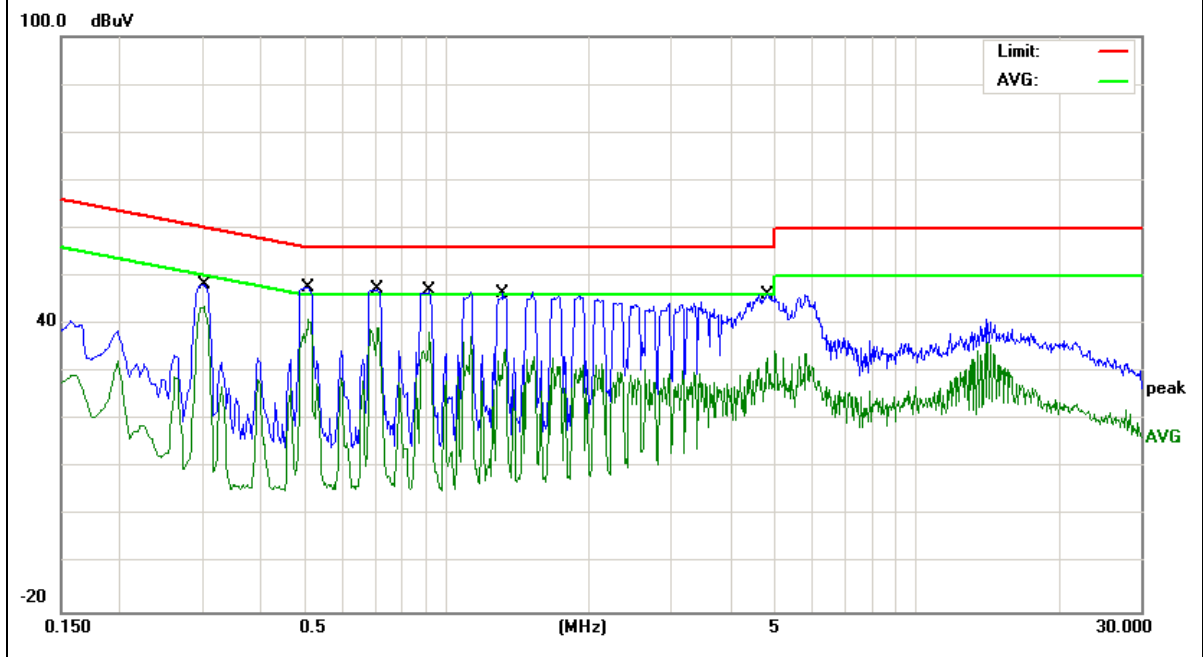

EUT :	U231AZZ-LE1	Model Name. :	U231AZZ-LE1
Temperature :	26 °C	Relative Humidity :	56%
Pressure :	1010hPa	Phase :	N
Test Voltage :	DC 12V from Adapter AC 120V/60Hz	Test Mode :	Mode 1(5.2G)

Frequency (MHz)	Reading Level (dBμV)	Correct Factor (dB)	Measurement (dBμV)	Limits (dBμV)	Margin (dB)	Remark
0.4980	38.41	9.54	47.95	56.03	-8.08	QP
0.4980	30.69	9.54	40.23	46.03	-5.80	AVG
0.7019	38.05	9.54	47.59	56.00	-8.41	QP
0.7019	27.91	9.54	37.45	46.00	-8.55	AVG
0.9140	37.44	9.55	46.99	56.00	-9.01	QP
0.9140	26.75	9.55	36.30	46.00	-9.70	AVG
1.1180	37.82	9.55	47.37	56.00	-8.63	QP
1.1180	28.30	9.55	37.85	46.00	-8.15	AVG
1.3180	37.72	9.55	47.27	56.00	-8.73	QP
1.3180	27.97	9.55	37.52	46.00	-8.48	AVG
5.9820	38.32	9.63	47.95	60.00	-12.05	QP
5.9820	27.01	9.63	36.64	50.00	-13.36	AVG

Remark:

1. All readings are Quasi-Peak and Average values.
2. Factor = Insertion Loss + Cable Loss.

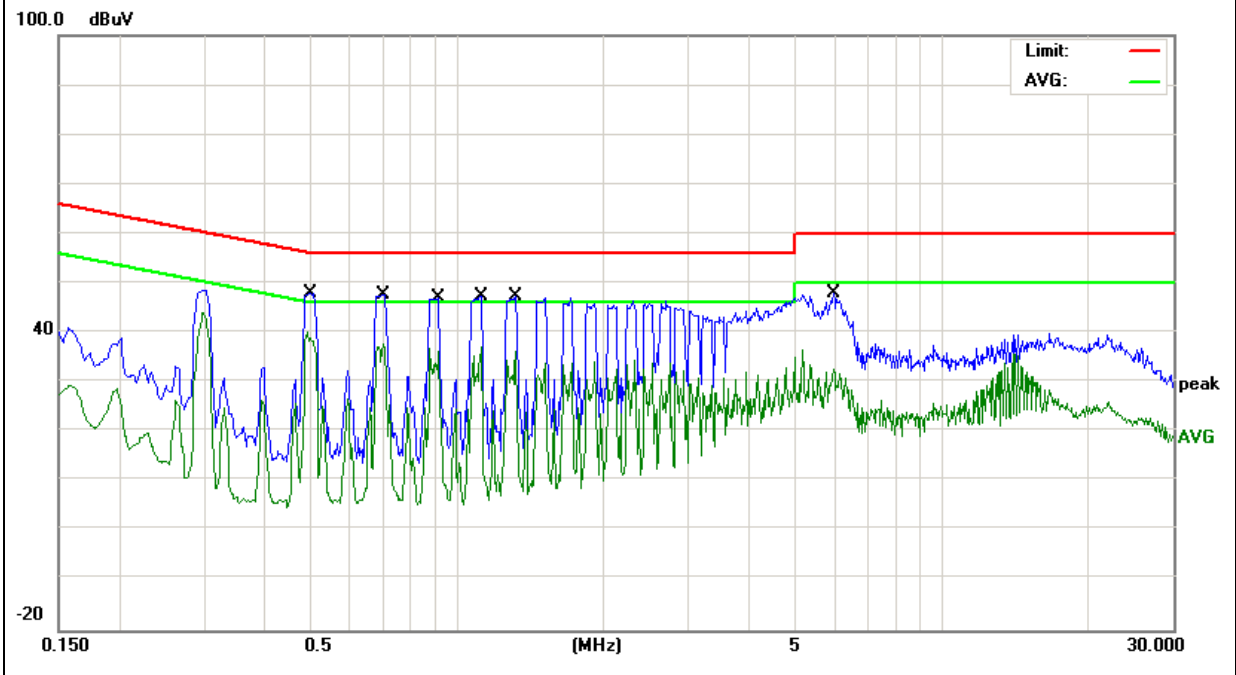

EUT :	U231AZZ-LE1	Model Name. :	U231AZZ-LE1
Temperature :	26 °C	Relative Humidity :	56%
Pressure :	1010hPa	Phase :	L
Test Voltage :	DC 12V from Adapter AC 120V/60Hz	Test Mode :	Mode 1(5.3G)

Frequency (MHz)	Reading Level (dBμV)	Correct Factor (dB)	Measurement (dBμV)	Limits (dBμV)	Margin (dB)	Remark
0.3020	40.64	9.54	50.18	60.19	-10.01	QP
0.3020	33.04	9.54	42.58	50.19	-7.61	AVG
0.5060	40.31	9.55	49.86	56.00	-6.14	QP
0.5060	29.33	9.55	38.88	46.00	-7.12	AVG
0.7019	39.64	9.55	49.19	56.00	-6.81	QP
0.7019	29.57	9.55	39.12	46.00	-6.88	AVG
0.9100	39.00	9.56	48.56	56.00	-7.44	QP
0.9100	29.02	9.56	38.58	46.00	-7.42	AVG
1.1140	39.24	9.56	48.80	56.00	-7.20	QP
1.1140	29.06	9.56	38.62	46.00	-7.38	AVG
4.9340	39.60	9.62	49.22	56.00	-6.78	QP
4.9340	22.65	9.62	32.27	46.00	-13.73	AVG

Remark:

1. All readings are Quasi-Peak and Average values.
2. Factor = Insertion Loss + Cable Loss.

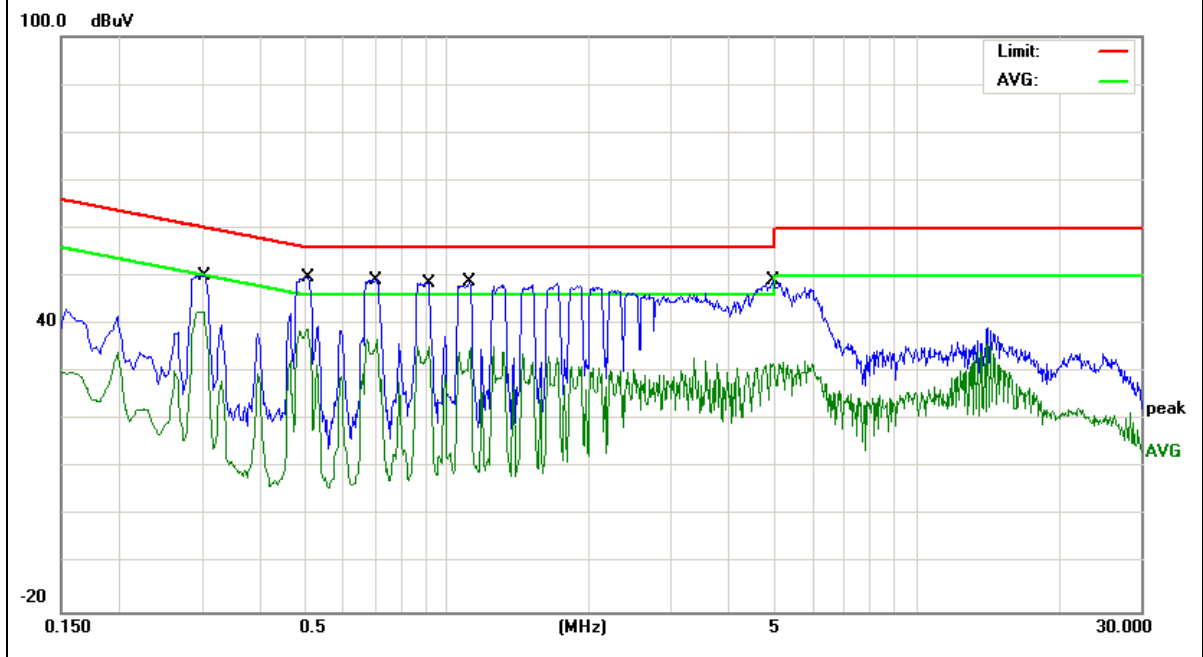

EUT :	U231AZZ-LE1	Model Name. :	U231AZZ-LE1
Temperature :	26 °C	Relative Humidity :	56%
Pressure :	1010hPa	Phase :	N
Test Voltage :	DC 12V from Adapter AC 120V/60Hz	Test Mode :	Mode 1(5.3G)

Frequency (MHz)	Reading Level (dBμV)	Correct Factor (dB)	Measurement (dBμV)	Limits (dBμV)	Margin (dB)	Remark
0.3019	40.24	9.53	49.77	60.19	-10.42	QP
0.3019	30.34	9.53	39.87	50.19	-10.32	AVG
0.5060	39.64	9.54	49.18	56.00	-6.82	QP
0.5060	29.01	9.54	38.55	46.00	-7.45	AVG
0.6939	38.84	9.54	48.38	56.00	-7.62	QP
0.6939	28.98	9.54	38.52	46.00	-7.48	AVG
0.9180	38.69	9.55	48.24	56.00	-7.76	QP
0.9180	29.14	9.55	38.69	46.00	-7.31	AVG
1.1180	39.04	9.55	48.59	56.00	-7.41	QP
1.1180	29.19	9.55	38.74	46.00	-7.26	AVG
5.2980	39.33	9.61	48.94	60.00	-11.06	QP
5.2980	23.99	9.61	33.60	50.00	-16.40	AVG

Remark:

1. All readings are Quasi-Peak and Average values.
2. Factor = Insertion Loss + Cable Loss.

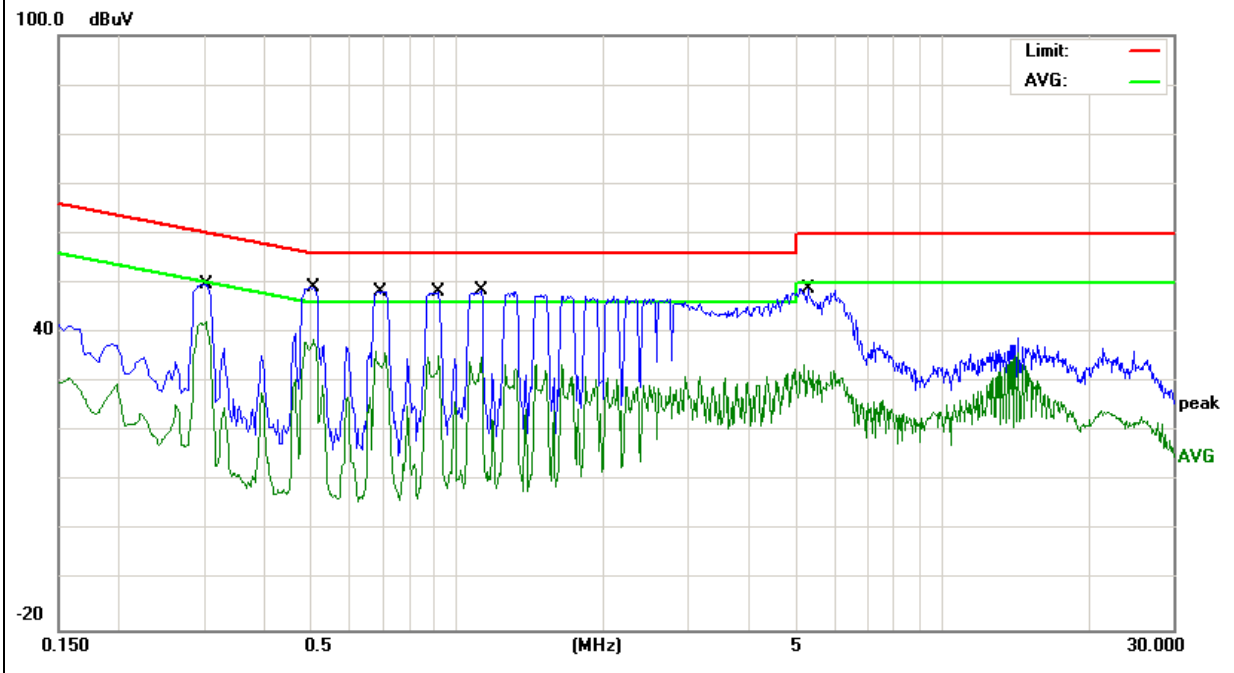

EUT :	U231AZZ-LE1	Model Name. :	U231AZZ-LE1
Temperature :	26 °C	Relative Humidity :	56%
Pressure :	1010hPa	Phase :	L
Test Voltage :	DC 12V from Adapter AC 120V/60Hz	Test Mode :	Mode 1(5.6G)

Frequency (MHz)	Reading Level (dBμV)	Correct Factor (dB)	Measure-ment (dBμV)	Limits (dBμV)	Margin (dB)	Remark
0.3019	39.64	9.54	49.18	60.19	-11.01	QP
0.3019	29.79	9.54	39.33	50.19	-10.86	AVG
0.4939	39.06	9.55	48.61	56.10	-7.49	QP
0.4939	28.71	9.55	38.26	46.10	-7.84	AVG
0.7018	38.64	9.55	48.19	56.00	-7.81	QP
0.7018	28.90	9.55	38.45	46.00	-7.55	AVG
0.9100	37.50	9.56	47.06	56.00	-8.94	QP
0.9100	28.13	9.56	37.69	46.00	-8.31	AVG
1.7098	37.89	9.58	47.47	56.00	-8.53	QP
1.7098	27.60	9.58	37.18	46.00	-8.82	AVG
2.1299	37.32	9.58	46.90	56.00	-9.10	QP
2.1299	28.44	9.58	38.02	46.00	-7.98	AVG

Remark:

1. All readings are Quasi-Peak and Average values.
2. Factor = Insertion Loss + Cable Loss.

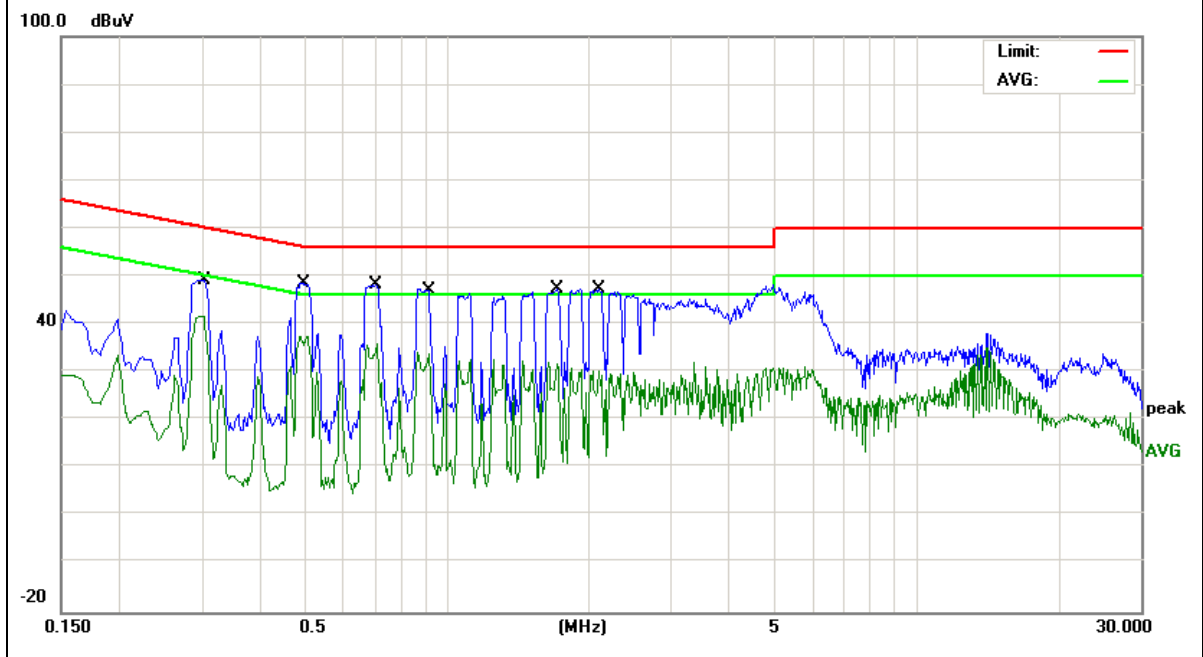

EUT :	U231AZZ-LE1	Model Name. :	U231AZZ-LE1
Temperature :	26 °C	Relative Humidity :	56%
Pressure :	1010hPa	Phase :	N
Test Voltage :	DC 12V from Adapter AC 120V/60Hz	Test Mode :	Mode 1(5.6G)

Frequency (MHz)	Reading Level (dBμV)	Correct Factor (dB)	Measurement (dBμV)	Limits (dBμV)	Margin (dB)	Remark
0.3019	39.24	9.53	48.77	60.19	-11.42	QP
0.3019	28.72	9.53	38.25	50.19	-11.94	AVG
0.5060	39.14	9.54	48.68	56.00	-7.32	QP
0.5060	29.15	9.54	38.69	46.00	-7.31	AVG
0.6937	37.84	9.54	47.38	56.00	-8.62	QP
0.6937	27.61	9.54	37.15	46.00	-8.85	AVG
1.1180	38.04	9.55	47.59	56.00	-8.41	QP
1.1180	27.60	9.55	37.15	46.00	-8.85	AVG
1.5260	38.01	9.57	47.58	56.00	-8.42	QP
1.5260	27.69	9.57	37.26	46.00	-8.74	AVG
5.2979	38.33	9.61	47.94	60.00	-12.06	QP
5.2979	28.24	9.61	37.85	50.00	-12.15	AVG

Remark:

1. All readings are Quasi-Peak and Average values.
2. Factor = Insertion Loss + Cable Loss.

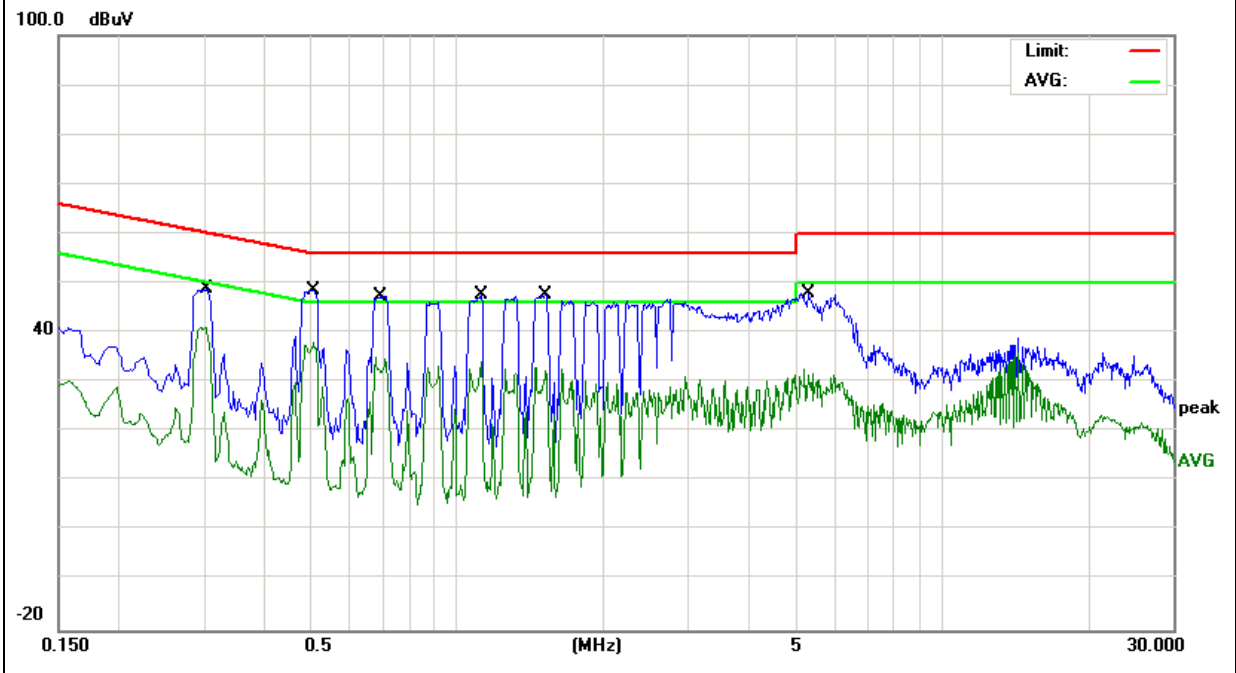

EUT :	U231AZZ-LE1	Model Name. :	U231AZZ-LE1
Temperature :	26 °C	Relative Humidity :	56%
Pressure :	1010hPa	Phase :	L
Test Voltage :	DC 12V from Adapter AC 120V/60Hz	Test Mode :	Mode 1(5.8G)

Frequency (MHz)	Reading Level (dBμV)	Correct Factor (dB)	Measure-ment (dBμV)	Limits (dBμV)	Margin (dB)	Remark
0.3019	39.14	9.54	48.68	60.19	-11.51	QP
0.3019	29.12	9.54	38.66	50.19	-11.53	AVG
0.4939	38.66	9.55	48.21	56.10	-7.89	QP
0.4939	28.70	9.55	38.25	46.10	-7.85	AVG
0.7017	37.64	9.55	47.19	56.00	-8.81	QP
0.7017	27.93	9.55	37.48	46.00	-8.52	AVG
0.9100	38.00	9.56	47.56	56.00	-8.44	QP
0.9100	28.13	9.56	37.69	46.00	-8.31	AVG
1.1140	38.24	9.56	47.80	56.00	-8.20	QP
1.1140	27.62	9.56	37.18	46.00	-8.82	AVG
1.7097	37.89	9.58	47.47	56.00	-8.53	QP
1.7097	27.75	9.58	37.33	46.00	-8.67	AVG

Remark:

1. All readings are Quasi-Peak and Average values.
2. Factor = Insertion Loss + Cable Loss.

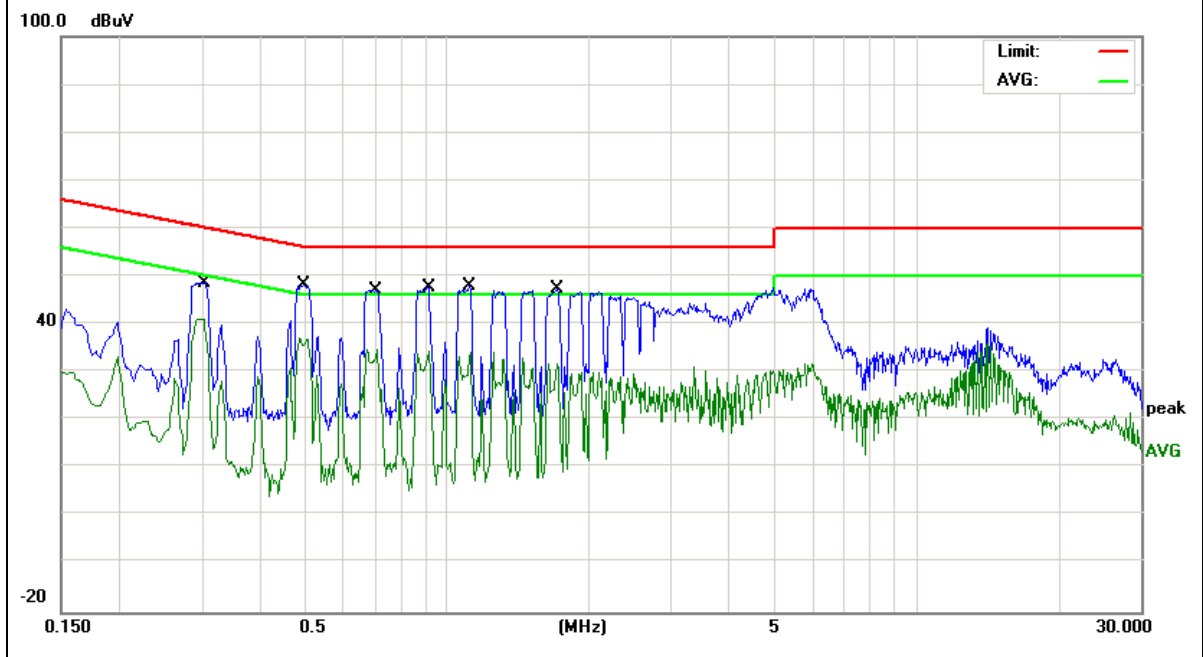

EUT :	U231AZZ-LE1	Model Name. :	U231AZZ-LE1
Temperature :	26 °C	Relative Humidity :	56%
Pressure :	1010hPa	Phase :	N
Test Voltage :	DC 12V from Adapter AC 120V/60Hz	Test Mode :	Mode 1(5.8G)

Frequency (MHz)	Reading Level (dBμV)	Correct Factor (dB)	Measurement (dBμV)	Limits (dBμV)	Margin (dB)	Remark
0.3019	39.24	9.53	48.77	60.19	-11.42	QP
0.3019	28.80	9.53	38.33	50.19	-11.86	AVG
0.5060	38.14	9.54	47.68	56.00	-8.32	QP
0.5060	28.15	9.54	37.69	46.00	-8.31	AVG
0.6936	37.84	9.54	47.38	56.00	-8.62	QP
0.6936	27.05	9.54	36.59	46.00	-9.41	AVG
0.9180	37.69	9.55	47.24	56.00	-8.76	QP
0.9180	28.47	9.55	38.02	46.00	-7.98	AVG
1.3220	36.18	9.55	45.73	56.00	-10.27	QP
1.3220	26.13	9.55	35.68	46.00	-10.32	AVG
5.1299	36.73	9.61	46.34	60.00	-13.66	QP
5.1299	27.14	9.61	36.75	50.00	-13.25	AVG

Remark:

1. All readings are Quasi-Peak and Average values.
2. Factor = Insertion Loss + Cable Loss.

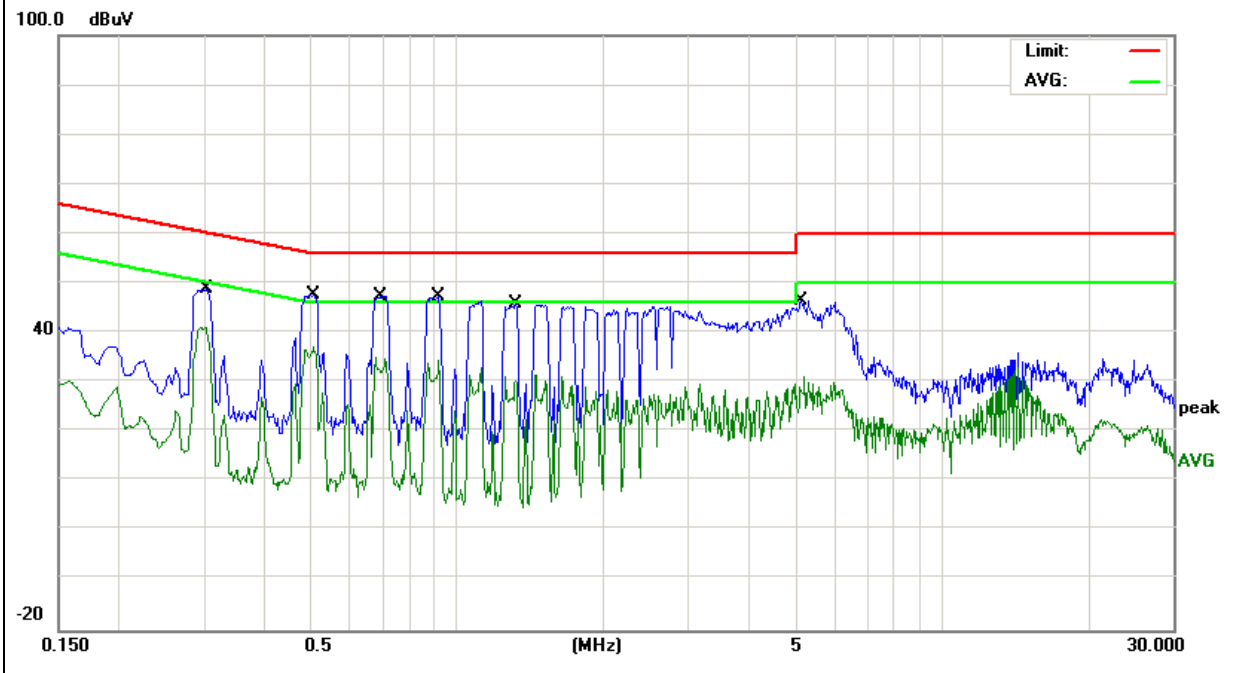



## 2.2 RADIATED EMISSION MEASUREMENT

### 2.2.1 APPLICABLE STANDARD

According to FCC Part 15.407(d) and 15.209

### 2.2.2 CONFORMANCE LIMIT

According to FCC Part 15.407(b)(7): radiated emissions which fall in the restricted bands, as defined in §15.205(a), must also comply with the radiated emission limits specified in §15.209(a) (see §15.205(c)).  
According to FCC Part 15.205, Restricted bands

MHz	MHz	MHz	GHz
0.090-0.110	16.42-16.423	399.9-410	4.5-5.15
0.495-0.505	16.69475-16.69525	608-614	5.35-5.46
2.1735-2.1905	16.80425-16.80475	960-1240	7.25-7.75
4.125-4.128	25.5-25.67	1300-1427	8.025-8.5
4.17725-4.17775	37.5-38.25	1435-1626.5	9.0-9.2
4.20725-4.20775	73-74.6	1645.5-1646.5	9.3-9.5
6.215-6.218	74.8-75.2	1660-1710	10.6-12.7
6.26775-6.26825	123-138	2200-2300	14.47-14.5
8.291-8.294	149.9-150.05	2310-2390	15.35-16.2
8.362-8.366	156.52475-156.52525	2483.5-2500	17.7-21.4
8.37625-8.38675	156.7-156.9	2690-2900	22.01-23.12
8.41425-8.41475	162.0125-167.17	3260-3267	23.6-24.0
12.29-12.293	167.72-173.2	3332-3339	31.2-31.8
12.51975-12.52025	240-285	3345.8-3358	36.43-36.5
12.57675-12.57725	322-335.4	3600-4400	(2)
13.36-13.41			

20dBc in any 100 kHz bandwidth outside the operating frequency band. In case the emission fall within the restricted band specified on 15.205(a), then the 15.209(a) limit in the table below has to be followed.

Restricted Frequency(MHz)	Field Strength ( $\mu\text{V}/\text{m}$ )	Field Strength ( $\text{dB}\mu\text{V}/\text{m}$ )	Measurement Distance
0.009~0.490	2400/F(KHz)	20 log ( $\mu\text{V}/\text{m}$ )	300
0.490~1.705	24000/F(KHz)	20 log ( $\mu\text{V}/\text{m}$ )	30
1.705~30.0	30	29.5	30
30-88	100	40	3
88-216	150	43.5	3
216-960	200	46	3
Above 960	500	54	3

Limits of Radiated Emission Measurement(Above 1000MHz)

Frequency(MHz)	Class B ( $\text{dB}\mu\text{V}/\text{m}$ ) (at 3M)	
	PEAK	AVERAGE
Above 1000	74	54

Remark : 1. Emission level in  $\text{dB}\mu\text{V}/\text{m}=20 \log (\mu\text{V}/\text{m})$   
 2. Measurement was performed at an antenna to the closed point of EUT distance of meters.  
 3. For Frequency 9kHz~30MHz:  
 Distance extrapolation factor =  $40 \log (\text{Specific distance}/ \text{test distance})(\text{dB})$ ;  
 Limit line=Specific limits( $\text{dB}\mu\text{V}$ ) + distance extrapolation factor.  
 For Frequency above 30MHz:  
 Distance extrapolation factor =  $20 \log (\text{Specific distance}/ \text{test distance})(\text{dB})$ ;  
 Limit line=Specific limits( $\text{dB}\mu\text{V}$ ) + distance extrapolation factor.

### 2.2.3 MEASURING INSTRUMENTS

The Measuring equipment is listed in the section 6.3 of this test report.

2.2.4 TEST CONFIGURATION

(a) For radiated emissions below 30MHz

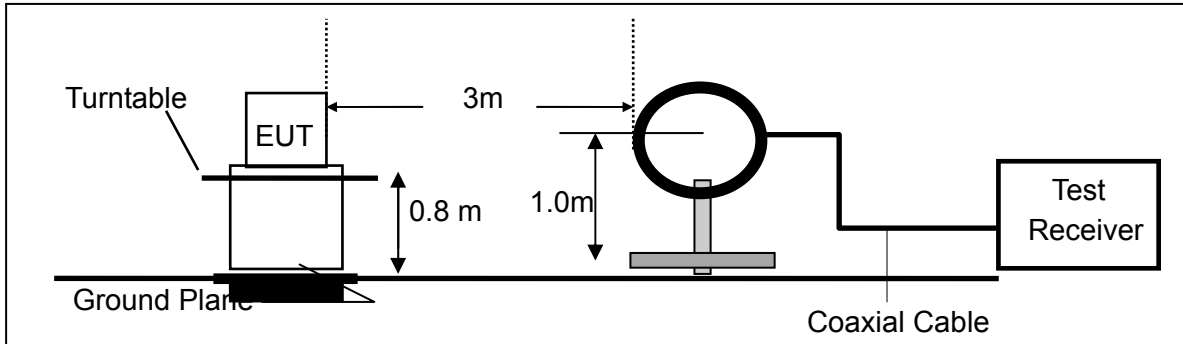

(b) For radiated emissions from 30MHz to 1000MHz

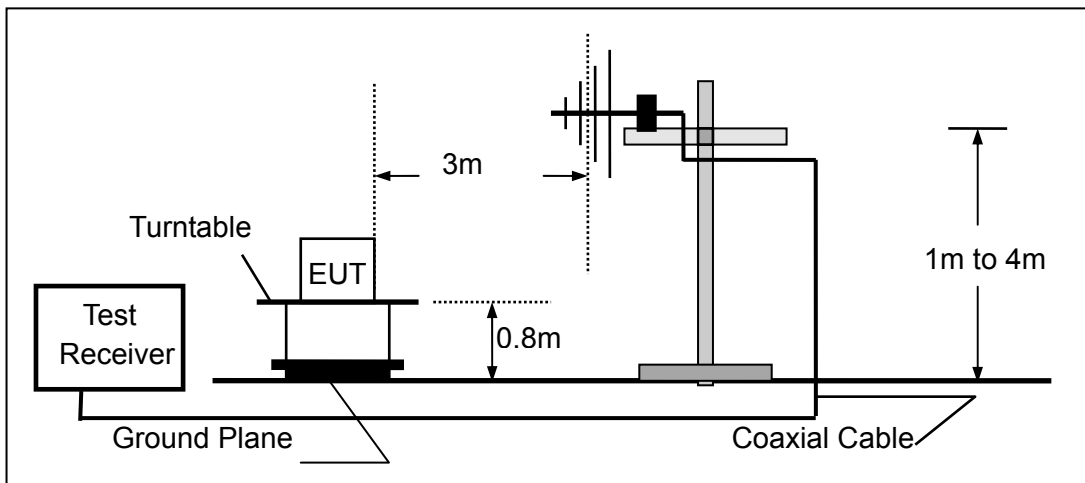

(c) For radiated emissions above 1000MHz

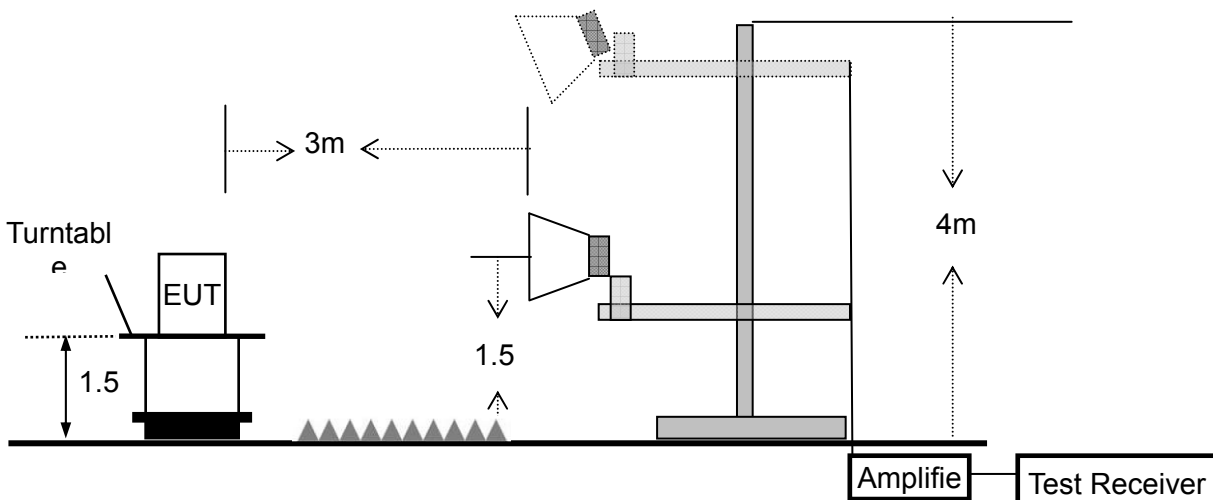

### 2.2.5 TEST PROCEDURE

The test site semi-anechoic chamber has met the requirement of NSA tolerance 4 dB according to the standards: ANSI C63.10-2013. The test distance is 3m. The setup is according to the requirements in Section 13.1.4.1 of ANSI C63.10-2013 and CAN/CSA-CEI/IEC CISPR 22.

This test is required for any spurious emission that falls in a Restricted Band, as defined in Section 15.205. It must be performed with the highest gain of each type of antenna proposed for use with the EUT.

Use the following spectrum analyzer settings:

Spectrum Parameter	Setting
Attenuation	Auto
Start Frequency	1000 MHz
Stop Frequency	10th carrier harmonic
RB / VB (emission in restricted band)	1 MHz / 1 MHz for Peak, 1 MHz / 10Hz for Average

Receiver Parameter	Setting
Attenuation	Auto
Start ~ Stop Frequency	9kHz~150kHz / RB 200Hz for QP
Start ~ Stop Frequency	150kHz~30MHz / RB 9kHz for QP
Start ~ Stop Frequency	30MHz~1000MHz / RB 120kHz for QP

- The measuring distance of at 3 m shall be used for measurements at frequency up to 1GHz. For frequencies above 1GHz, any suitable measuring distance may be used.
- The EUT was placed on the top of a rotating table 0.8 m for below 1GHz and 1.5m for above 1GHz the ground at a 3 meter. The table was rotated 360 degrees to determine the position of the highest radiation.
- The height of the equipment or of the substitution antenna shall be 0.8 m for below 1GHz and 1.5m for above 1GHz; the height of the test antenna shall vary between 1 m to 4 m. Both horizontal and vertical polarizations of the antenna are set to make the measurement.
- The initial step in collecting conducted emission data is a spectrum analyzer peak detector mode pre-scanning the measurement frequency range. Significant peaks are then marked and then Quasi Peak detector mode re-measured.
- If the Peak Mode measured value compliance with and lower than Quasi Peak Mode Limit, the EUT shall be deemed to meet QP Limits and then no additional QP Mode measurement performed.
- For the actual test configuration, please refer to the related Item –EUT Test Photos.

Note:

Both horizontal and vertical antenna polarities were tested and performed pretest to three orthogonal axis. The worst case emissions were reported

During the radiated emission test, the Spectrum Analyzer was set with the following configurations:

Frequency Band (MHz)	Function	Resolution bandwidth	Video Bandwidth
30 to 1000	QP	120 kHz	300 kHz
Above 1000	Peak	1 MHz	1 MHz
	Average	1 MHz	10 Hz

Note: for the frequency ranges below 30 MHz, a narrower RBW is used for these ranges but the measured value should add a RBW correction factor (RBWCF) where  $RBWCF [dB] = 10 \cdot \lg(100 [kHz] / \text{narrower RBW [kHz]})$ . , the narrower RBW is 1 kHz and RBWCF is 20 dB for the frequency 9 kHz to 150 kHz, and the narrower RBW is 10 kHz and RBWCF is 10 dB for the frequency 150 kHz to 30 MHz.

**2.2.6 TEST RESULTS (9KHZ – 30 MHZ)**

EUT :	U231AZZ-LE1	Model Name :	U231AZZ-LE1
Temperature :	26 °C	Relative Humidity :	54%
Pressure:	1010 hPa	Test Voltage :	DC 12V
Test Mode :	TX	Polarization :	--

Freq.	Reading	Limit	Margin	State
(MHz)	(dBuV/m)	(dBuV/m)	(dB)	P/F
--	--	--	--	N/A
--	--	--	--	N/A

**NOTE:**

The amplitude of spurious emissions which are attenuated by more than 20dB below the permissible value has no need to be reported.

**2.2.7 TEST RESULTS (30MHZ – 1GHZ)**

EUT :	U231AZZ-LE1	Model Name :	U231AZZ-LE1
Temperature :	26 °C	Relative Humidity :	54%
Pressure :	1010 hPa	Test Voltage :	DC 12V
Test Mode :	TX(5.2G)- 802.11a (Low CH)		

Polar (H/V)	Frequency	Meter Reading	Factor	Emission Level	Limits	Margin	Remark
	(MHz)	(dBuV)	(dB)	(dBuV/m)	(dBuV/m)	(dB)	
V	40.7014	19.90	13.58	33.48	40.00	-6.52	QP
V	47.1599	23.77	10.78	34.55	40.00	-5.45	QP
V	101.6443	22.91	11.08	33.99	43.50	-9.51	QP
V	110.5687	23.93	11.35	35.28	43.50	-8.22	QP
V	400.4319	13.38	17.92	31.30	46.00	-14.70	QP
V	590.9737	16.02	21.43	37.45	46.00	-8.55	QP

**Remark:**

Emission Level= Meter Reading+ Factor, Margin= Emission Level - Limit

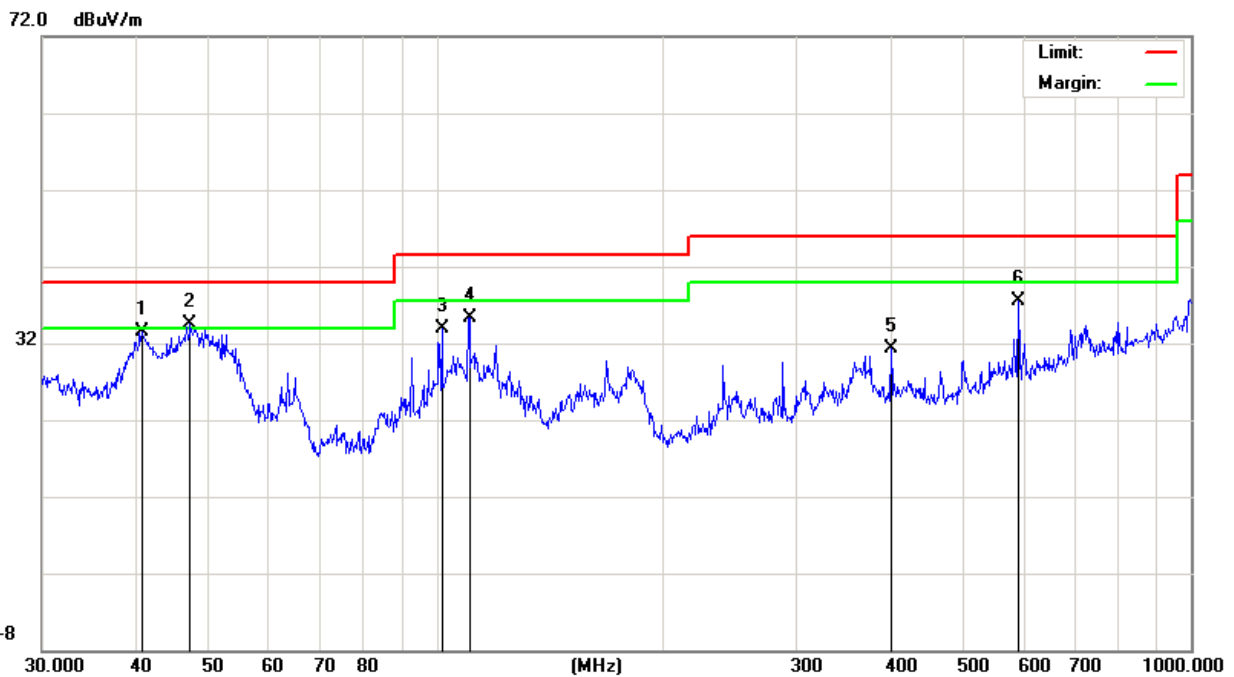

Polar (H/V)	Frequency	Meter Reading	Factor	Emission Level	Limits	Margin	Remark
	(MHz)	(dBuV)	(dB)	(dBuV/m)	(dBuV/m)	(dB)	
H	105.2718	19.05	11.10	30.15	43.50	-13.35	QP
H	124.1330	19.12	12.20	31.32	43.50	-12.18	QP
H	239.9874	22.06	11.73	33.79	46.00	-12.21	QP
H	590.9737	20.44	21.43	41.87	46.00	-4.13	QP
H	701.7610	18.14	22.96	41.10	46.00	-4.90	QP
H	1000.000	12.53	28.07	40.60	54.00	-13.40	QP

**Remark:**

Emission Level= Meter Reading+ Factor, Margin= Emission Level - Limit

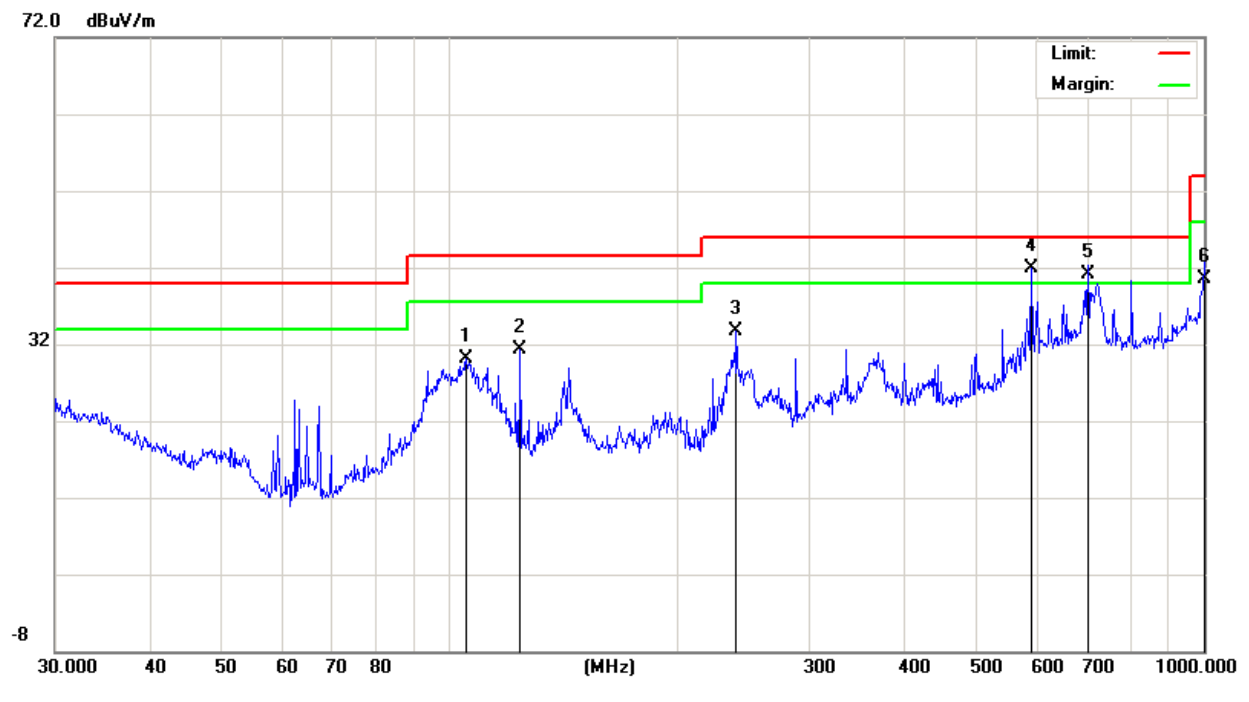

EUT :	U231AZZ-LE1	Model Name :	U231AZZ-LE1
Temperature :	26 °C	Relative Humidity :	54%
Pressure :	1010 hPa	Test Voltage :	DC 12V
Test Mode :	TX(5.3G)- 802.11n20 (Middle CH)		

Polar (H/V)	Frequency	Meter Reading	Factor	Emission Level	Limits	Margin	Remark
	(MHz)	(dBuV)	(dB)	(dBuV/m)	(dBuV/m)	(dB)	
V	47.8260	24.57	10.84	35.41	40.00	-4.59	QP
V	79.8003	24.58	8.05	32.63	40.00	-7.37	QP
V	112.1305	22.32	11.72	34.04	43.50	-9.46	QP
V	239.9874	20.11	11.73	31.84	46.00	-14.16	QP
V	590.9737	14.88	21.43	36.31	46.00	-9.69	QP
V	801.7863	19.13	24.97	44.10	46.00	-1.90	QP

**Remark:**

Emission Level= Meter Reading+ Factor, Margin= Emission Level - Limit

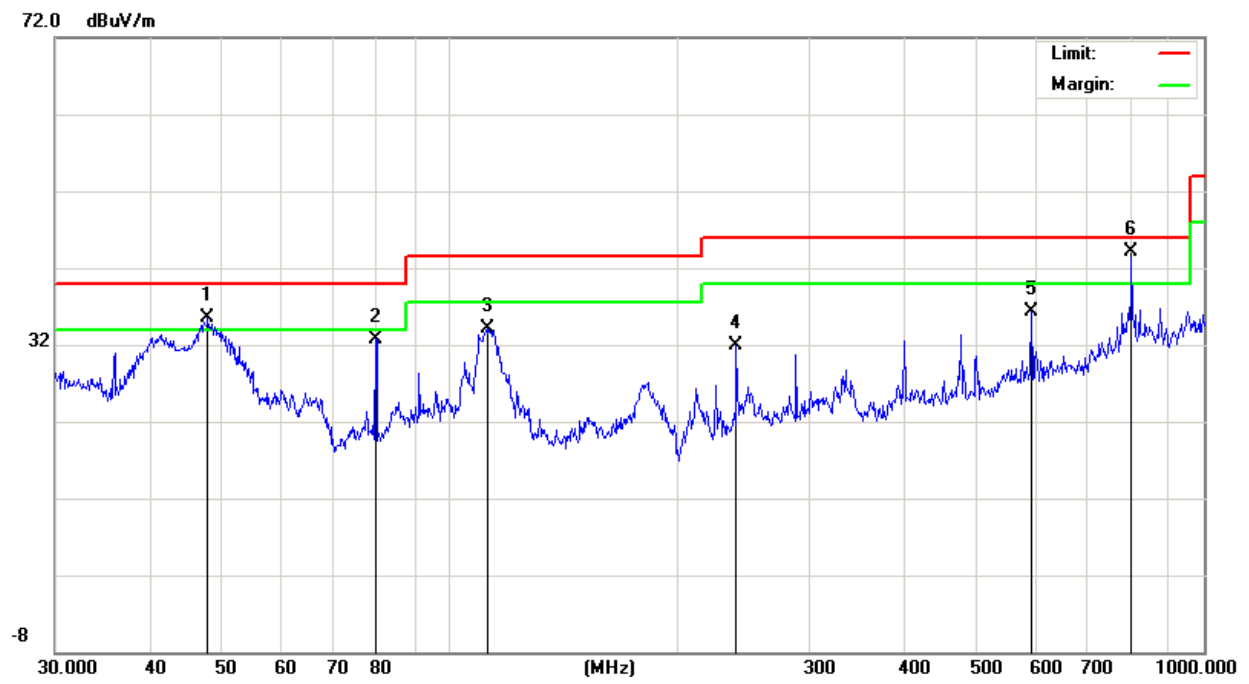

Polar (H/V)	Frequency	Meter Reading	Factor	Emission Level	Limits	Margin	Remark
	(MHz)	(dBuV)	(dB)	(dBuV/m)	(dBuV/m)	(dB)	
H	112.9196	18.69	11.92	30.61	43.50	-12.89	QP
H	213.0151	23.87	9.88	33.75	43.50	-9.75	QP
H	590.9737	18.58	21.43	40.01	46.00	-5.99	QP
H	801.7863	18.73	24.97	43.70	46.00	-2.30	QP
H	875.2470	16.61	25.72	42.33	46.00	-3.67	QP
H	1000.000	11.51	28.07	39.58	54.00	-14.42	QP

**Remark:**

Emission Level= Meter Reading+ Factor, Margin= Emission Level - Limit

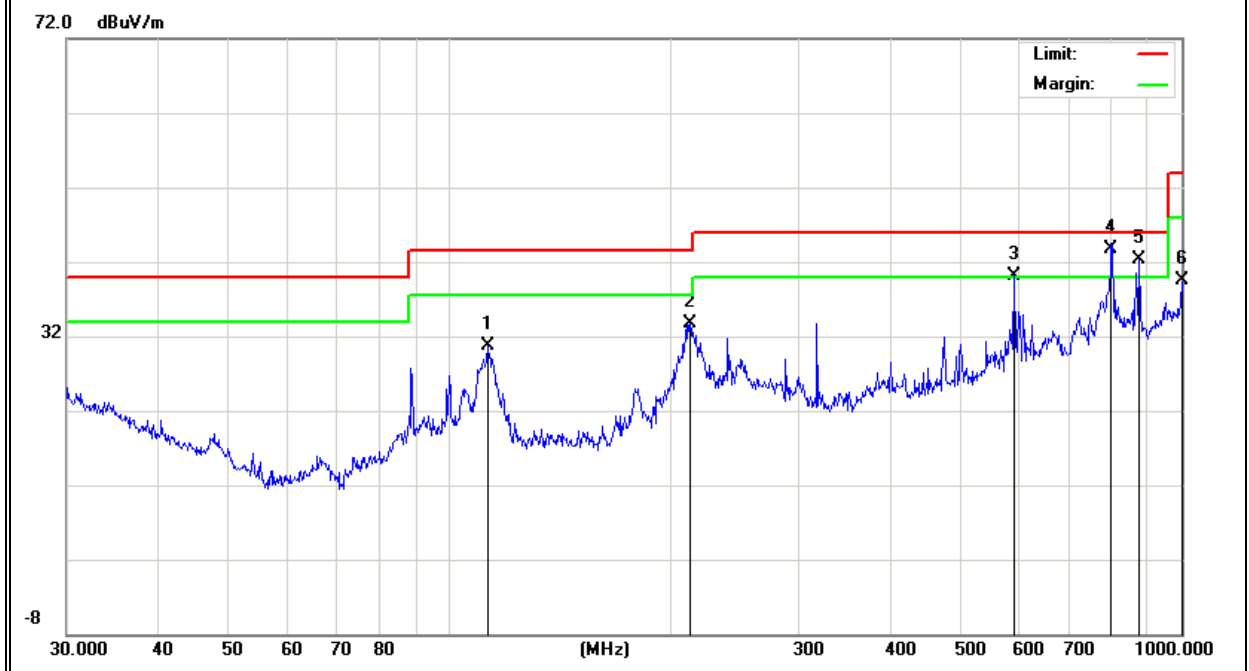



EUT :	U231AZZ-LE1	Model Name :	U231AZZ-LE1
Temperature :	26 °C	Relative Humidity :	54%
Pressure :	1010 hPa	Test Voltage :	DC 12V
Test Mode :	TX(5.6G)- 802.11n20 (Low CH)		

Polar (H/V)	Frequency	Meter Reading	Factor	Emission Level	Limits	Margin	Remark
	(MHz)	(dBuV)	(dB)	(dBuV/m)	(dBuV/m)	(dB)	
V	48.3318	18.28	10.58	28.86	40.00	-11.14	QP
V	112.9196	19.70	11.92	31.62	43.50	-11.88	QP
V	181.2834	17.26	9.96	27.22	43.50	-16.28	QP
V	400.4319	16.64	17.92	34.56	46.00	-11.44	QP
V	590.9737	15.07	21.43	36.50	46.00	-9.50	QP
V	801.7863	18.56	24.97	43.53	46.00	-2.47	QP

**Remark:**

Emission Level= Meter Reading+ Factor, Margin= Emission Level - Limit

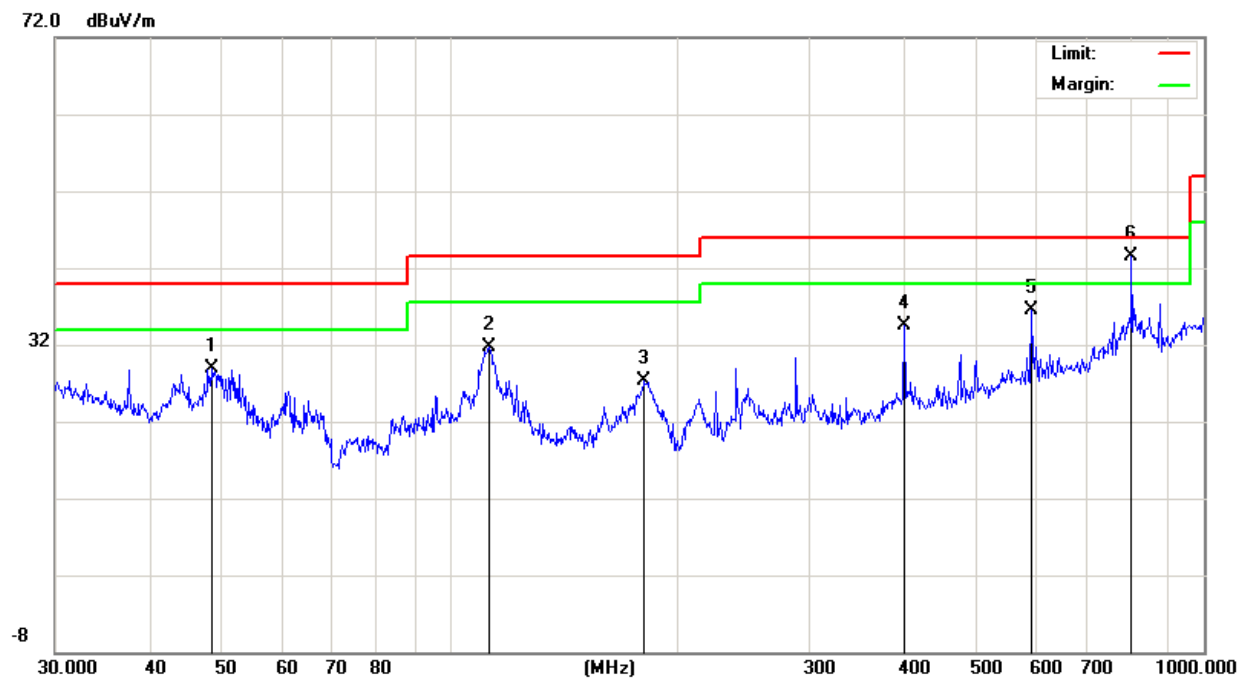

Polar (H/V)	Frequency	Meter Reading	Factor	Emission Level	Limits	Margin	Remark
	(MHz)	(dBUV)	(dB)	(dBUV/m)	(dBUV/m)	(dB)	
H	84.1100	17.96	8.65	26.61	40.00	-13.39	QP
H	111.3468	17.42	11.53	28.95	43.50	-14.55	QP
H	213.0151	24.57	9.88	34.45	43.50	-9.05	QP
H	590.9737	18.44	21.43	39.87	46.00	-6.13	QP
H	801.7863	20.63	24.97	45.60	46.00	-0.40	QP
H	878.3214	15.91	25.63	41.54	46.00	-4.46	QP

**Remark:**

Emission Level= Meter Reading+ Factor, Margin= Emission Level - Limit

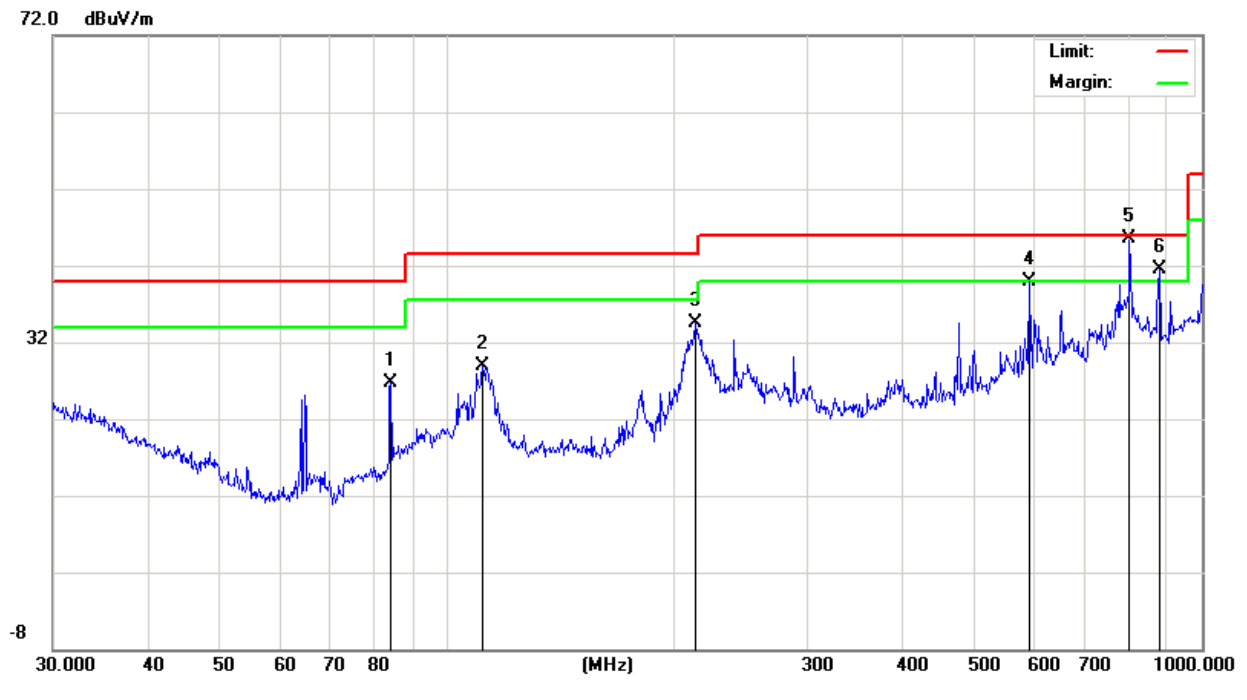

EUT :	U231AZZ-LE1	Model Name :	U231AZZ-LE1
Temperature :	26 °C	Relative Humidity :	54%
Pressure :	1010 hPa	Test Voltage :	DC 12V
Test Mode :	TX(5.8G) - 802.11a (Low CH)		

Polar (H/V)	Frequency	Meter Reading	Factor	Emission Level	Limits	Margin	Remark
	(MHz)	(dBuV)	(dB)	(dBuV/m)	(dBuV/m)	(dB)	
V	31.1798	17.46	18.21	35.67	40.00	-4.33	QP
V	46.6664	24.37	10.73	35.10	40.00	-4.90	QP
V	59.0251	28.97	6.13	35.10	40.00	-4.90	QP
V	92.4624	24.06	10.20	34.26	43.50	-9.24	QP
V	113.3161	21.98	12.02	34.00	43.50	-9.50	QP
V	801.7863	17.80	24.97	42.77	46.00	-3.23	QP

**Remark:**

Emission Level= Meter Reading+ Factor, Margin= Emission Level - Limit

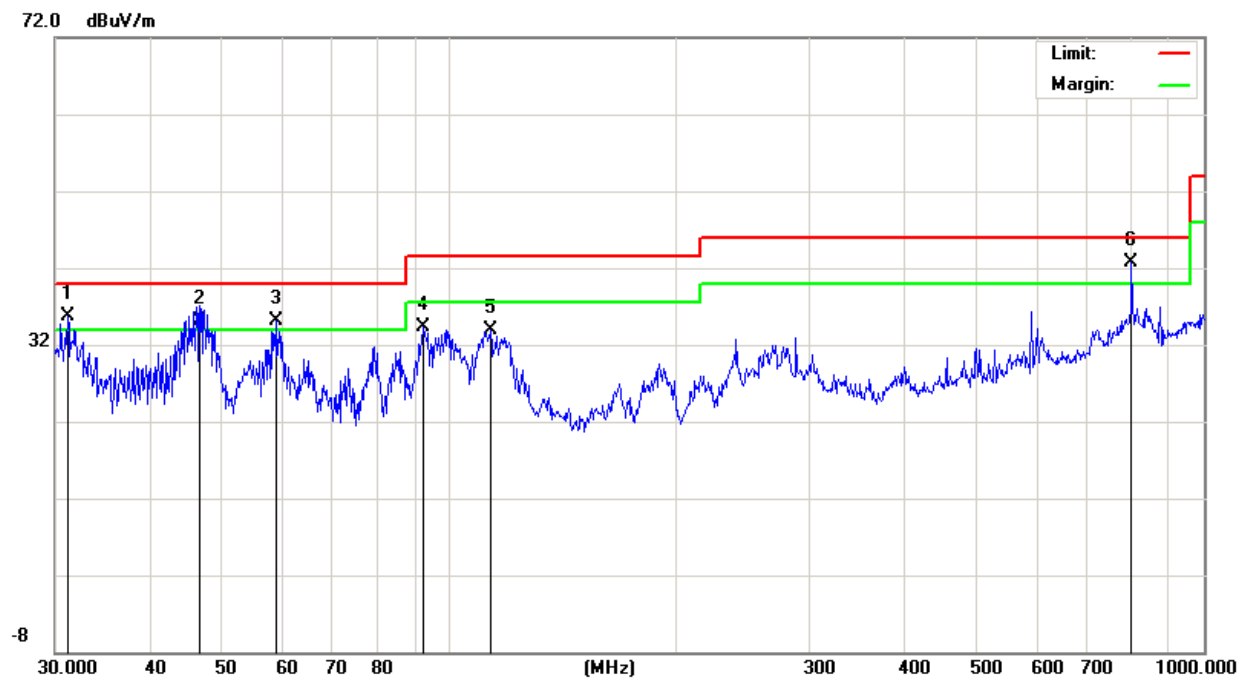

Polar (H/V)	Frequency	Meter Reading	Factor	Emission Level	Limits	Margin	Remark
	(MHz)	(dBuV)	(dB)	(dBuV/m)	(dBuV/m)	(dB)	
H	100.9338	17.47	11.07	28.54	43.50	-14.96	QP
H	111.7380	18.87	11.63	30.50	43.50	-13.00	QP
H	213.0151	24.68	9.88	34.56	43.50	-8.94	QP
H	601.4265	19.47	21.74	41.21	46.00	-4.79	QP
H	721.7259	16.86	24.02	40.88	46.00	-5.12	QP
H	801.7863	15.41	24.97	40.38	46.00	-5.62	QP

**Remark:**

Emission Level= Meter Reading+ Factor, Margin= Emission Level - Limit

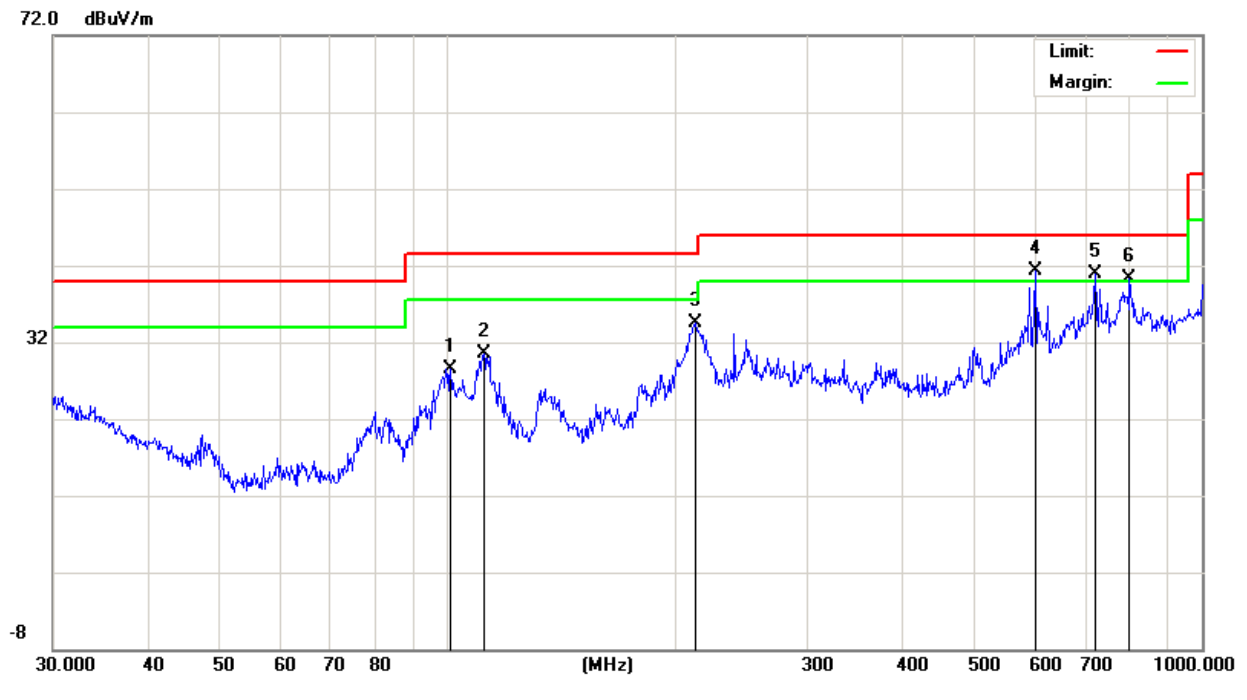

Note: All modes have been tested, just the the worst mode has been recorded in the report.

### 2.2.8 TEST RESULTS (1GHz-18GHz)

EUT :	U231AZZ-LE1	Model Name. :	U231AZZ-LE1
Temperature :	20 °C	Relative Humidity :	48%
Pressure :	1010 hPa	Test Voltage :	DC 12V
Test Mode :	TX(5.2G) - 802.11a_5180~5240MHz		

Polar	Frequency	Meter Reading	Cable loss	Antenna Factor	Preamp Factor	Emission Level	Limits	Margin	Detector Type
(H/V)	(MHz)	(dBuV)	(dB)	dB/m	(dB)	(dBuV/m)	(dBuV/m)	(dB)	
Low Channel (5180 MHz)-Above 1G									
Vertical	3015	59.36	5.94	35.40	44.00	56.70	68.2	-11.50	Pk
Vertical	10360	56.39	8.46	39.75	44.50	60.10	68.2	-8.10	AV
Vertical	15540	59.72	10.12	38.80	44.10	64.54	74	-9.46	Pk
Vertical	15540	45.06	10.12	38.80	42.70	51.28	54	-2.72	Pk
Horizontal	2981	55.48	5.94	35.18	44.00	52.60	68.2	-15.60	AV
Horizontal	10360	59.26	8.46	38.71	44.50	61.93	68.2	-6.27	Pk
Horizontal	15540	59.26	10.12	38.38	44.10	63.66	74	-10.34	Pk
Horizontal	15540	45.38	10.12	38.38	44.10	49.78	54	-4.22	AV
middle Channel (5200 MHz)-Above 1G									
Vertical	3561	58.12	6.48	36.35	44.05	56.90	68.2	-11.30	Pk
Vertical	10400	56.01	8.47	37.88	44.51	57.85	68.2	-10.35	AV
Vertical	15600	60.6	10.12	38.80	44.10	65.42	74	-8.58	Pk
Vertical	15600	43.24	10.12	38.80	42.70	49.46	54	-4.54	Pk
Horizontal	3363	58.62	6.48	36.37	44.05	57.42	68.2	-10.78	AV
Horizontal	10400	57.29	8.47	38.64	44.50	59.90	68.2	-8.30	Pk
Horizontal	15600	60.37	10.12	38.38	44.10	64.77	74	-9.23	Pk
Horizontal	15600	43.76	10.12	38.38	44.10	48.16	54	-5.84	AV
High Channel (5240 MHz)-Above 1G									
Vertical	3926	59.97	7.10	37.24	43.50	60.81	74	-13.19	Pk
Vertical	3926	40.43	7.10	37.24	43.50	41.27	54	-12.73	AV
Vertical	10480	58.89	8.46	37.68	44.50	60.53	68.2	-7.67	Pk
Vertical	15720	57.8	10.12	38.80	44.10	62.62	74	-11.38	AV
Vertical	15720	44.01	10.12	38.80	42.70	50.23	54	-3.77	Pk
Horizontal	3885	58.66	7.10	37.24	43.50	59.50	74	-14.50	AV
Horizontal	3885	41.86	7.10	37.24	43.50	42.70	54	-11.30	Pk
Horizontal	10480	56.54	8.46	38.57	44.50	59.07	68.2	-9.13	AV
Horizontal	15720	58.62	10.12	38.38	44.10	63.02	74	-10.98	Pk
Horizontal	15720	45.36	10.12	38.38	44.10	49.76	54	-4.24	AV

Note: "802.11a (5G)" mode is the worst mode. PK value is lower than the Average value limit, So average didn't record.

The amplitude of spurious emissions that are attenuated by more than 20dB below the permissible value has no need to be reported.

Emission level (dBuV/m) = 20 log Emission level (uV/m).

Corrected Reading: Antenna Factor + Cable Loss + Read Level - Preamp Factor = Level.

EUT :	U231AZZ-LE1	Model Name. :	U231AZZ-LE1
Temperature :	20 °C	Relative Humidity :	48%
Pressure :	1010 hPa	Test Voltage :	DC 12V
Test Mode :	TX(5.3G) - 802.11n20_5260~5320MHz		

Polar	Frequency	Meter Reading	Cable loss	Antenna Factor	Preamp Factor	Emission Level	Limits	Margin	Detector Type
(H/V)	(MHz)	(dBuV)	(dB)	dB/m	(dB)	(dBuV/m)	(dBuV/m)	(dB)	
Low Channel (5260 MHz)-Above 1G									
Vertical	4633.53	61.25	5.44	35.40	44.00	58.10	74.00	-15.90	Pk
Vertical	4633.53	42.73	5.74	35.40	44.00	39.87	54.00	-14.13	AV
Vertical	10520.40	58.68	8.26	39.75	44.50	62.19	68.20	-6.01	Pk
Vertical	15780.62	60.01	10.12	38.80	44.10	64.83	74.00	-9.17	Pk
Vertical	15780.62	38.88	9.62	38.80	42.70	44.60	54.00	-9.40	AV
Horizontal	4366.43	63.40	5.57	35.18	44.00	60.14	74.00	-13.86	Pk
Horizontal	4366.43	42.66	5.74	35.18	44.00	39.58	54.00	-14.42	AV
Horizontal	10520.54	58.47	8.38	38.71	44.50	61.06	68.20	-7.14	Pk
Horizontal	15780.62	56.62	9.88	38.38	44.10	60.78	74.00	-13.22	Pk
Horizontal	15780.62	39.62	9.94	38.38	44.10	43.84	54.00	-10.16	AV
middle Channel (5280 MHz)-Above 1G									
Vertical	4122.62	58.06	6.08	36.35	44.05	56.44	74.00	-17.56	Pk
Vertical	4122.62	41.69	6.39	36.35	44.05	40.38	54.00	-13.62	AV
Vertical	10560.47	58.80	8.28	37.88	44.51	60.45	68.20	-7.75	Pk
Vertical	15840.64	60.53	9.79	38.8	44.10	65.01	74.00	-8.99	Pk
Vertical	15840.64	38.68	9.70	38.8	42.70	44.48	54.00	-9.52	AV
Horizontal	3869.76	57.80	6.11	36.37	44.05	56.23	74.00	-17.77	Pk
Horizontal	3869.76	45.11	6.27	36.37	44.05	43.70	54.00	-10.30	AV
Horizontal	10561.02	61.28	8.33	38.64	44.50	63.75	68.20	-4.45	Pk
Horizontal	15840.65	59.30	9.99	38.38	44.10	63.57	74.00	-10.43	Pk
Horizontal	15840.65	39.92	9.81	38.38	44.10	44.01	54.00	-9.99	AV
High Channel (5320 MHz)-Above 1G									
Vertical	5366.80	61.48	6.96	37.24	43.50	62.18	74.00	-11.82	Pk
Vertical	5366.80	42.48	7.07	37.24	43.50	43.28	54.00	-10.72	AV
Vertical	10640.86	60.87	8.14	37.68	44.50	62.19	74.00	-11.81	Pk
Vertical	10640.86	40.59	8.35	37.68	44.50	42.12	54.00	-11.88	AV
Vertical	15960.69	59.67	10.11	38.8	44.10	64.47	74.00	-9.53	Pk
Vertical	15960.69	37.95	9.64	38.8	42.70	43.70	54.00	-10.30	AV
Horizontal	5436.87	60.45	7.05	37.24	43.50	61.24	74.00	-12.76	Pk
Horizontal	5436.87	40.72	7.05	37.24	43.50	41.51	54.00	-12.49	AV
Horizontal	10640.52	59.65	8.20	38.57	44.50	61.92	74.00	-12.08	Pk
Horizontal	10640.52	42.40	8.03	38.57	44.50	44.50	54.00	-9.50	AV
Horizontal	15961.16	59.37	9.81	38.38	44.10	63.47	74.00	-10.53	Pk
Horizontal	15961.16	42.40	9.96	38.38	44.10	46.64	54.00	-7.36	AV

Note: ANT 1 802.11n20(5G) mode is the worst mode. PK value is lower than the Average value limit, So average didn't record.

The amplitude of spurious emissions that are attenuated by more than 20dB below the permissible value has no need to be reported.

Emission level (dBuV/m) = 20 log Emission level (uV/m).

Corrected Reading: Antenna Factor + Cable Loss + Read Level - Preamp Factor = Level.

EUT :	U231AZZ-LE1	Model Name. :	U231AZZ-LE1
Temperature :	20 °C	Relative Humidity :	48%
Pressure :	1010 hPa	Test Voltage :	DC 12V
Test Mode :	TX(5.6G) - 802.11n20_5500~5700MHz		

Polar	Frequency	Meter Reading	Cable loss	Antenna Factor	Preamp Factor	Emission Level	Limits	Margin	Detector Type
(H/V)	(MHz)	(dBuV)	(dB)	dB/m	(dB)	(dBuV/m)	(dBuV/m)	(dB)	
Low Channel (5500 MHz)-Above 1G									
Vertical	5433.30	62.22	5.61	35.40	44.00	59.23	74.00	-14.77	Pk
Vertical	5433.30	43.05	5.76	35.40	44.00	40.21	54.00	-13.79	AV
Vertical	11000.53	57.99	8.24	39.75	44.50	61.48	74.00	-12.52	Pk
Vertical	11000.53	39.85	8.35	39.75	44.50	43.45	54.00	-10.55	AV
Vertical	16500.69	48.98	10.05	38.80	44.10	53.73	68.20	-14.47	Pk
Horizontal	5126.75	58.51	5.78	35.18	44.00	55.47	74.00	-18.53	Pk
Horizontal	5126.75	40.46	5.66	35.18	44.00	37.31	54.00	-16.69	AV
Horizontal	11000.60	56.19	8.22	38.71	44.50	58.62	74.00	-15.38	Pk
Horizontal	11000.60	39.55	8.14	38.71	44.50	41.90	54.00	-12.10	AV
Horizontal	16500.75	59.82	10.04	38.38	44.10	64.14	68.20	-4.06	Pk
middle Channel (5600 MHz)-Above 1G									
Vertical	4933.53	60.65	6.29	36.35	44.05	59.23	74.00	-14.77	Pk
Vertical	4933.53	42.21	6.24	36.35	44.05	40.75	54.00	-13.25	AV
Vertical	11200.86	57.86	8.24	37.88	44.51	59.48	74.00	-14.52	Pk
Vertical	11200.86	42.49	8.13	37.88	44.51	43.98	54.00	-10.02	AV
Vertical	16800.73	57.89	9.71	38.80	44.10	62.30	68.20	-5.90	Pk
Horizontal	4766.60	58.44	6.44	36.37	44.05	57.20	74.00	-16.80	Pk
Horizontal	4766.60	41.38	6.13	36.37	44.05	39.84	54.00	-14.16	AV
Horizontal	11200.73	58.83	8.31	38.64	44.50	61.28	74.00	-12.72	Pk
Horizontal	11200.73	41.07	8.04	38.64	44.50	43.25	54.00	-10.75	AV
Horizontal	16800.61	60.15	10.09	38.38	44.10	64.52	68.20	-3.68	Pk
High Channel (5700 MHz)-Above 1G									
Vertical	5647.61	59.98	6.79	37.24	43.50	60.51	68.20	-7.69	Pk
Vertical	11400.57	59.23	8.10	37.68	44.50	60.51	74.00	-13.49	Pk
Vertical	11400.57	40.58	8.23	37.68	44.50	41.99	54.00	-12.01	AV
Vertical	17100.82	60.04	9.70	38.80	44.10	64.45	68.20	-3.75	Pk
Horizontal	5433.54	58.84	6.74	37.24	43.50	59.32	74.00	-14.68	Pk
Horizontal	5433.54	40.71	6.74	37.24	43.50	41.19	54.00	-12.81	AV
Horizontal	11400.71	58.33	8.25	38.57	44.50	60.65	74.00	-13.35	Pk
Horizontal	11400.71	40.24	8.35	38.57	44.50	42.66	54.00	-11.34	AV

Note:"802.11n20(5G)" mode is the worst mode. PK value is lower than the Average value limit, So average didn't record.

The amplitude of spurious emissions that are attenuated by more than 20dB below the permissible value has no need to be reported.

Emission level (dBuV/m) = 20 log Emission level (uV/m).

Corrected Reading: Antenna Factor + Cable Loss + Read Level - Preamp Factor = Level.

EUT :	U231AZZ-LE1	Model Name. :	U231AZZ-LE1
Temperature :	20 °C	Relative Humidity :	48%
Pressure :	1010 hPa	Test Voltage :	DC 12V
Test Mode :	TX (5.8G) -- 802.11a_5745~5825MHz		

Polar	Frequency	Meter Reading	Cable loss	Antenna Factor	Preamp Factor	Emission Level	Limits	Margin	Detector Type
(H/V)	(MHz)	(dBuV)	(dB)	dB/m	(dB)	(dBuV/m)	(dBuV/m)	(dB)	
Low Channel (5745 MHz)-Above 1G									
Vertical	2806	55.48	5.94	35.40	44.00	52.82	74.00	-21.18	Pk
Vertical	2806	43.93	5.94	35.40	44.00	41.27	54.00	-12.73	AV
Vertical	11490	55.12	8.46	39.75	44.50	58.83	74.00	-15.17	Pk
Vertical	11490	45.03	8.46	39.75	44.50	48.74	54.00	-5.26	Pk
Vertical	17235	59.82	10.12	38.80	44.10	64.64	68.20	-3.56	AV
Horizontal	2911	59.89	5.94	35.18	44.00	57.01	68.20	-11.19	Pk
Horizontal	11490	55.55	8.46	38.71	44.50	58.22	74.00	-15.78	AV
Horizontal	11490	40.08	8.46	38.71	44.50	42.75	54.00	-11.25	Pk
Horizontal	17235	58.92	10.12	38.38	44.10	63.32	68.20	-4.88	Pk
middle Channel (5785 MHz)-Above 1G									
Vertical	3763	58.17	6.48	36.35	44.05	56.95	74.00	-17.05	Pk
Vertical	3763	40.99	6.48	36.35	44.05	39.77	54.00	-14.23	AV
Vertical	11570	57.79	8.47	37.88	44.51	59.63	74.00	-14.37	Pk
Vertical	11570	44.82	8.47	37.88	44.51	46.66	54.00	-7.34	Pk
Vertical	17355	56.19	10.12	38.8	44.10	61.01	68.20	-7.19	AV
Horizontal	3561	59.63	6.48	36.37	44.05	58.43	68.20	-9.77	Pk
Horizontal	11570	55.42	8.47	38.64	44.50	58.03	74.00	-15.97	AV
Horizontal	11570	42.52	8.47	38.64	44.50	45.13	54.00	-8.87	Pk
Horizontal	17355	58.71	10.12	38.38	44.10	63.11	68.20	-5.09	Pk
High Channel (5825 MHz)-Above 1G									
Vertical	3907	59.45	7.10	37.24	43.50	60.29	74.00	-13.71	Pk
Vertical	3907	43.14	7.10	37.24	43.50	43.98	54.00	-10.02	AV
Vertical	11650	60.51	8.46	37.68	44.50	62.15	74.00	-11.85	Pk
Vertical	11650	42.76	8.46	37.68	44.50	44.40	54.00	-9.60	AV
Vertical	17475	56.08	10.12	38.8	44.10	60.90	68.20	-7.30	Pk
Horizontal	3912	60.31	7.10	37.24	43.50	61.15	74.00	-12.85	AV
Horizontal	3912	44.22	7.10	37.24	43.50	45.06	54.00	-8.94	Pk
Horizontal	11650	60.83	8.46	38.57	44.50	63.36	74.00	-10.64	AV
Horizontal	11650	40.92	8.46	38.57	44.50	43.45	54.00	-10.55	Pk
Horizontal	17475	58.99	10.12	38.38	44.10	63.39	68.20	-4.81	AV

Note:"802.11a(5G)" mode is the worst mode. PK value is lower than the Average value limit, So average didn't record.

The amplitude of spurious emissions that are attenuated by more than 20dB below the permissible value has no need to be reported.

Emission level (dBuV/m) = 20 log Emission level (uV/m).

Corrected Reading: Antenna Factor + Cable Loss + Read Level - Preamp Factor = Level.



**2.2.10 TEST RESULTS (18GHz-40GHz)**

EUT :	U231AZZ-LE1	Model Name. :	U231AZZ-LE1
Temperature :	20 °C	Relative Humidity :	48%
Pressure :	1010 hPa	Test Voltage :	DC 12V
Test Mode :	TX (5.2G)-802.11ac40 5190MHz~5230MHz; TX (5.3G)-802.11n20 5260MHz~5320MHz; TX (5.6G)-802.11n20 5500MHz~5700MHz; TX (5.8G)-802.11n20 5745MHz~5825MHz		

All the modulation modes have been tested, and the worst result was report as below:  
 Low Channel (5190 MHz)-Above 1G

Horizontal

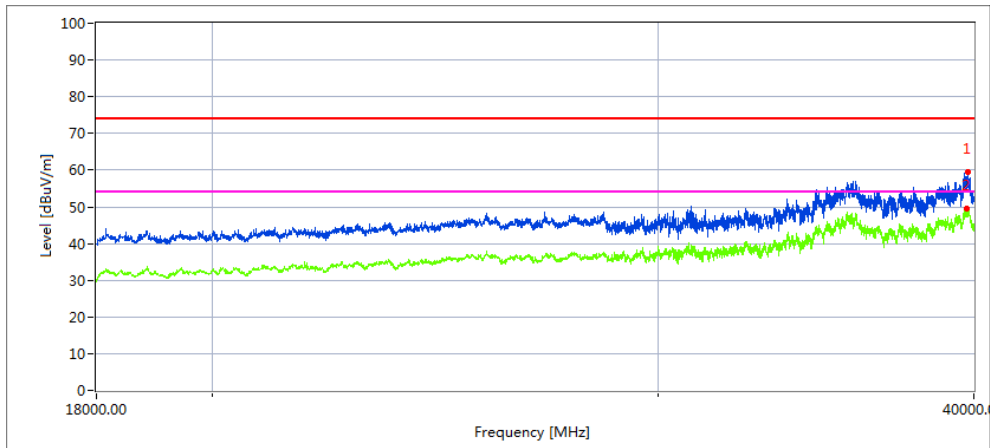

Frequency	Meter Reading	Cable loss	Antenna Factor	Preamp Factor	Emission Level	Limits	Margin	Remark
39769.27	38.72	20.09	44.07	43.48	59.4	68.2	8.8	Peak

Vertical

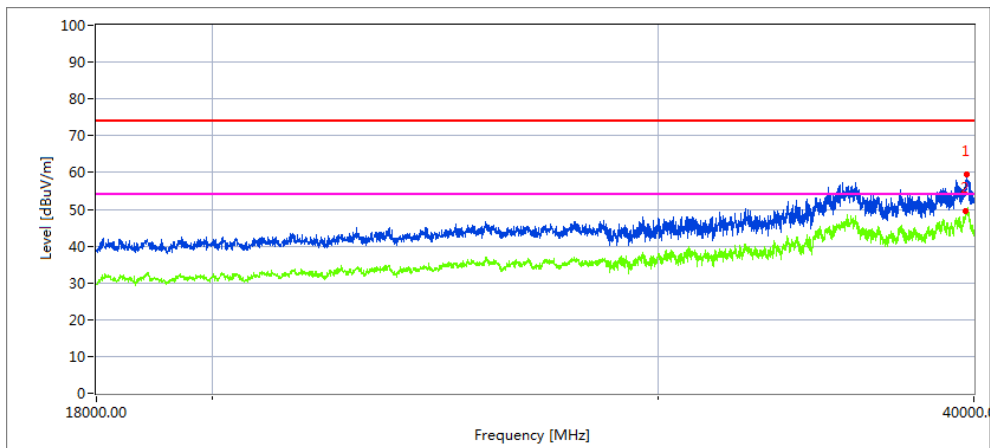

Frequency	Meter Reading	Cable loss	Antenna Factor	Preamp Factor	Emission Level	Limits	Margin	Remark
39769.546	35.58	20.09	44.07	43.48	56.26	68.2	11.94	Peak

### High Channel (5230 MHz)-Above 1G

Horizontal

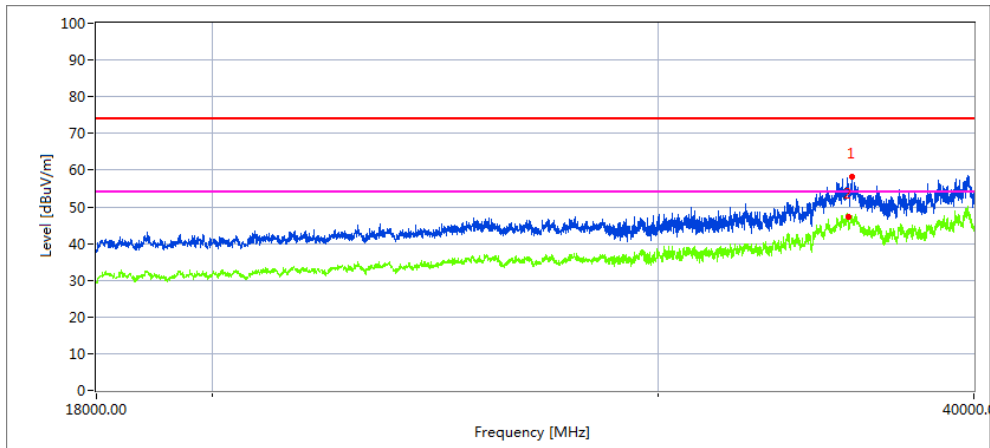

Frequency	Meter Reading	Cable loss	Antenna Factor	Preamp Factor	Emission Level	Limits	Margin	Remark
35628.37	40.73	19.11	42.73	44.61	57.96	68.2	10.24	Peak

Vertical

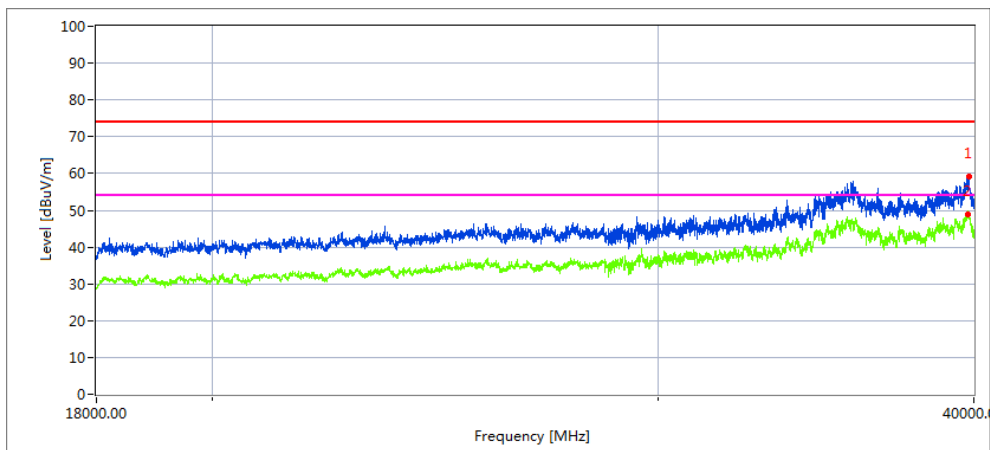

Frequency	Meter Reading	Cable loss	Antenna Factor	Preamp Factor	Emission Level	Limits	Margin	Remark
39769.476	36.68	20.09	44.07	43.48	57.36	68.2	10.84	Peak

Low Channel (5260 MHz)-Above 1G

Horizontal

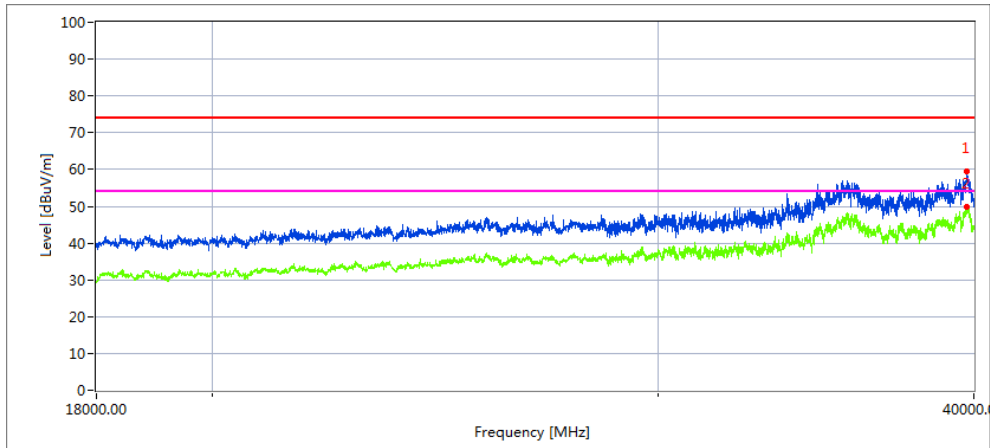

Frequency	Meter Reading	Cable loss	Antenna Factor	Preamp Factor	Emission Level	Limits	Margin	Remark
39176.23	38.35	19.98	43.84	44.62	57.55	68.2	10.65	Peak

Vertical

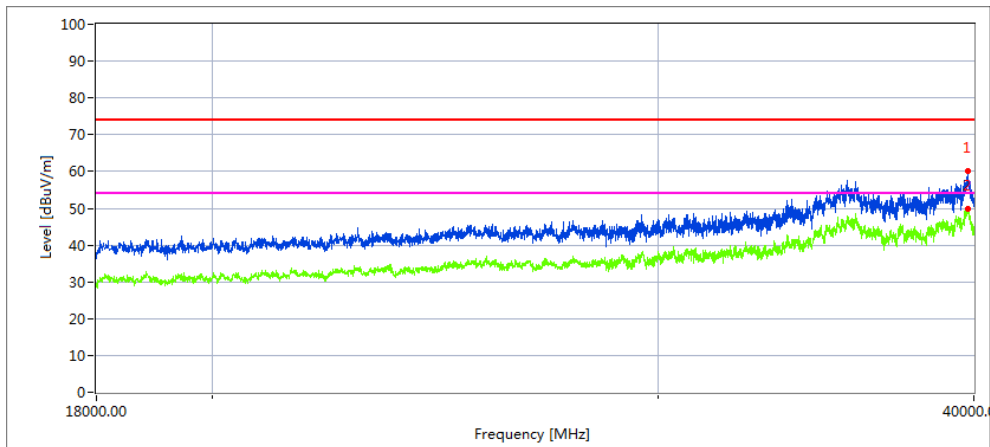

Frequency	Meter Reading	Cable loss	Antenna Factor	Preamp Factor	Emission Level	Limits	Margin	Remark
39385.84	38.63	20.01	44.06	42.69	60.01	68.2	8.19	Peak

High Channel (5320 MHz)-Above 1G

Horizontal

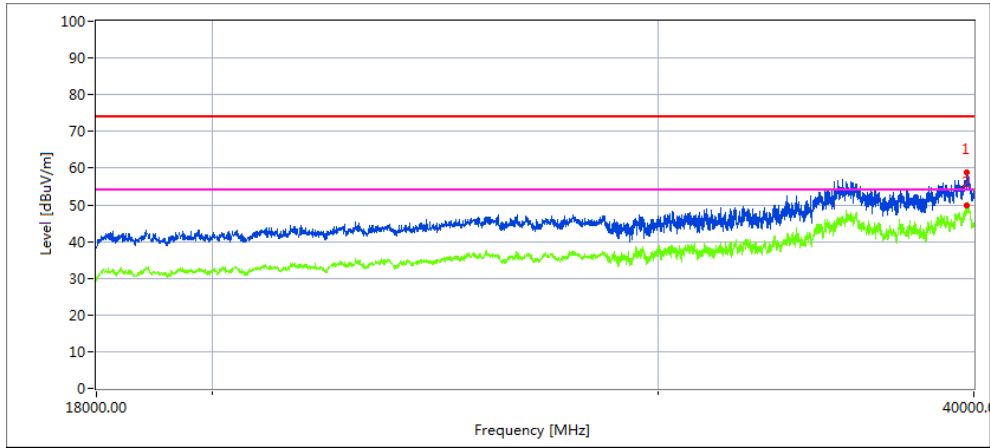

Frequency	Meter Reading	Cable loss	Antenna Factor	Preamp Factor	Emission Level	Limits	Margin	Remark
39176.94	38.55	19.98	43.84	44.62	57.75	68.2	10.45	Peak

Vertical

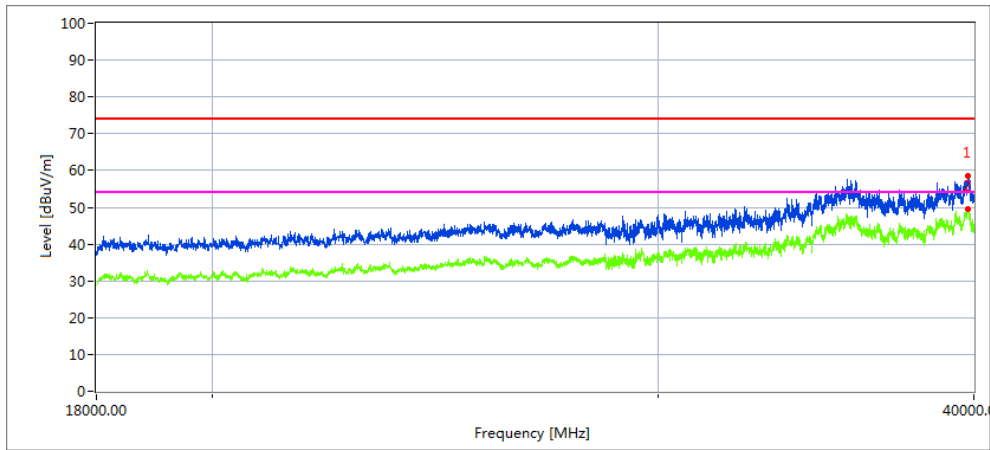

Frequency	Meter Reading	Cable loss	Antenna Factor	Preamp Factor	Emission Level	Limits	Margin	Remark
39369.174	35.43	20.01	44.06	42.69	56.81	68.2	11.39	Peak

Low Channel (5500 MHz)-Above 1G

Horizontal

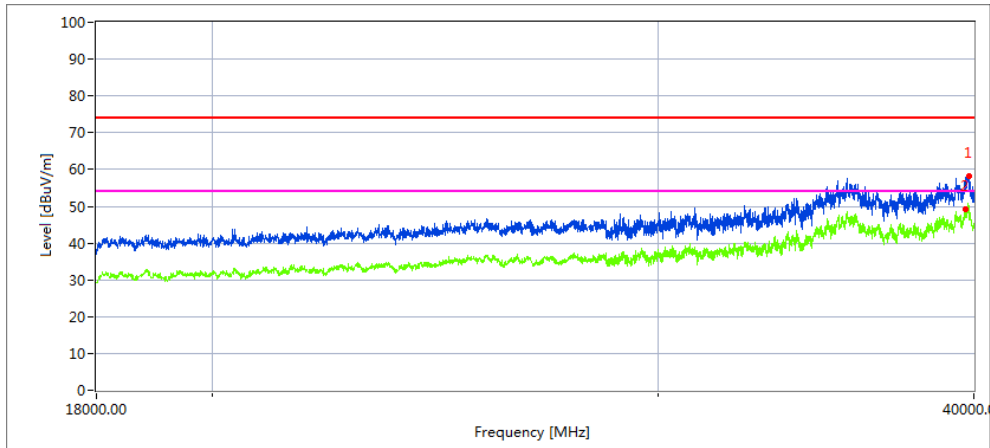

Frequency	Meter Reading	Cable loss	Antenna Factor	Preamp Factor	Emission Level	Limits	Margin	Remark
39696.437	36.82	20.09	44.07	43.48	57.5	68.2	10.7	Peak

Vertical

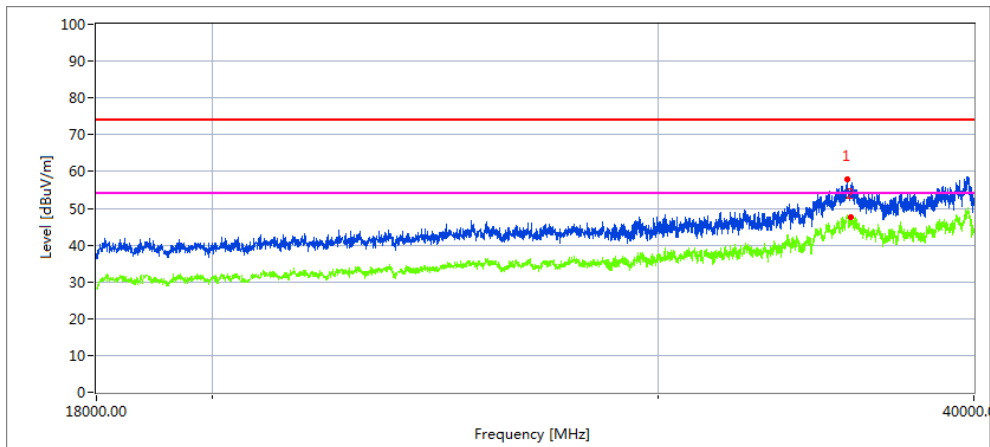

Frequency	Meter Reading	Cable loss	Antenna Factor	Preamp Factor	Emission Level	Limits	Margin	Remark
36575.641	36.9	19.16	42.61	41.56	57.11	68.2	11.09	Peak

### High Channel (5700 MHz)-Above 1G

Horizontal

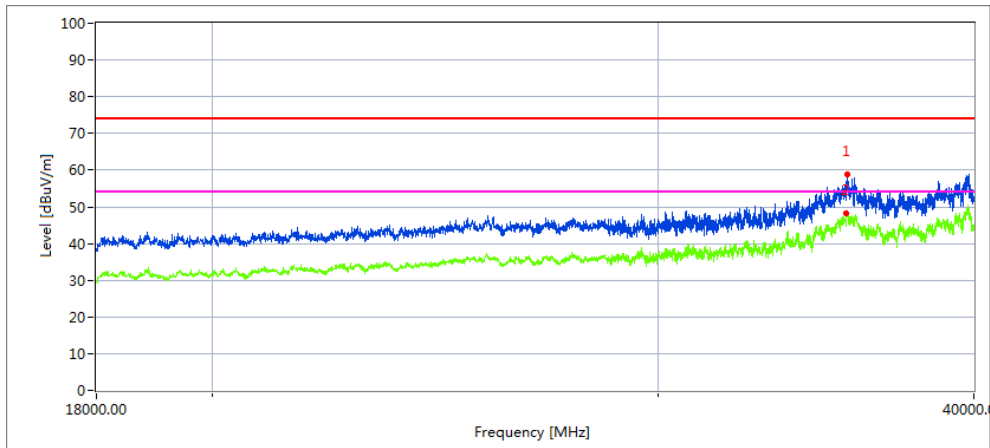

Frequency	Meter Reading	Cable loss	Antenna Factor	Preamp Factor	Emission Level	Limits	Margin	Remark
35794.5	37.23	19.17	42.63	42.74	56.29	68.2	11.91	Peak

Vertical

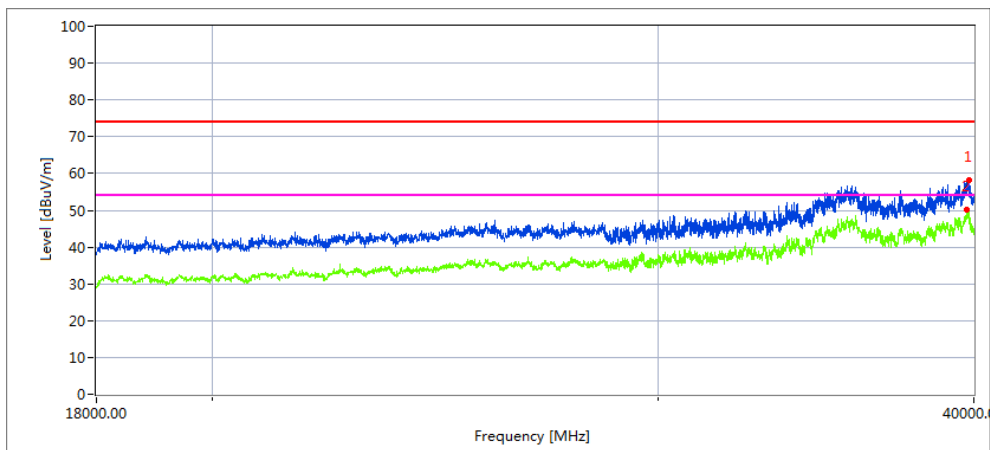

Frequency	Meter Reading	Cable loss	Antenna Factor	Preamp Factor	Emission Level	Limits	Margin	Remark
39816.733	38.24	20.09	42.63	43.48	57.48	68.2	10.72	Peak

Low Channel (5745 MHz)-Above 1G

Horizontal

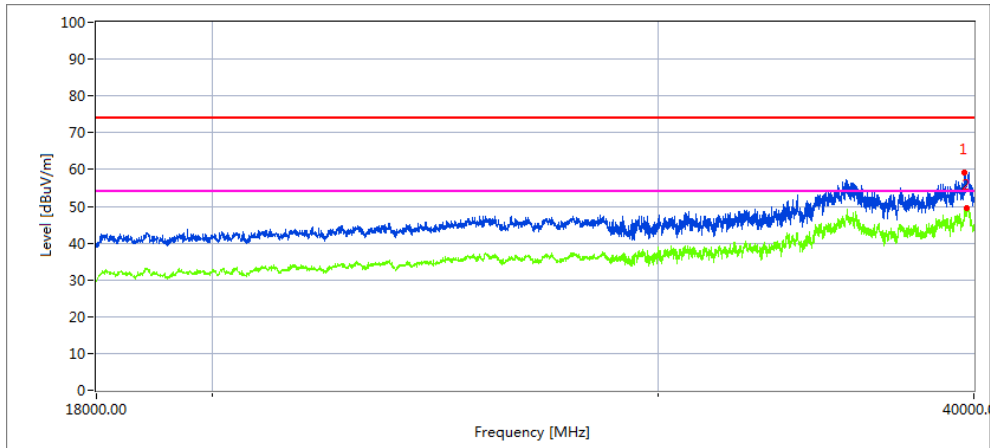

Frequency	Meter Reading	Cable loss	Antenna Factor	Preamp Factor	Emission Level	Limits	Margin	Remark
39670.224	38.27	20.09	44.16	43.48	59.04	68.2	9.16	Peak

Vertical

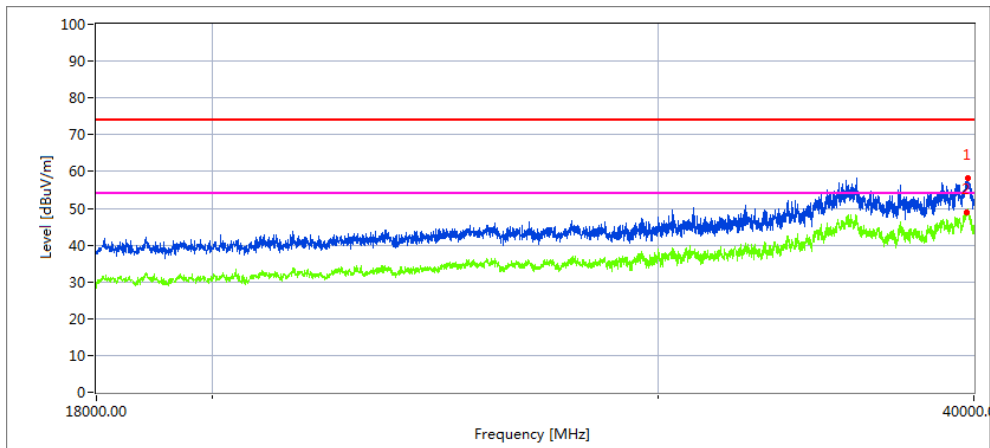

Frequency	Meter Reading	Cable loss	Antenna Factor	Preamp Factor	Emission Level	Limits	Margin	Remark
39731.342	36.98	20.06	44.07	43.21	57.9	68.2	10.3	Peak

### High Channel (5825 MHz)-Above 1G

Horizontal

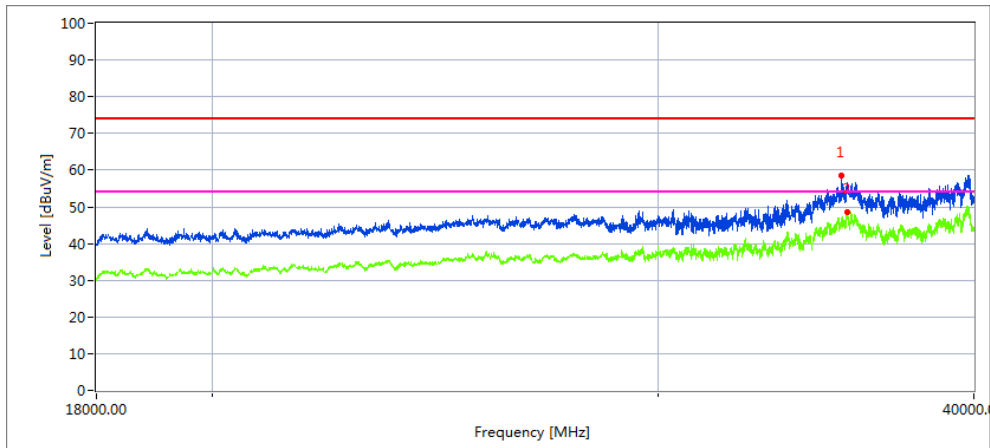

Frequency	Meter Reading	Cable loss	Antenna Factor	Preamp Factor	Emission Level	Limits	Margin	Remark
35628.534	39.32	19.11	42.63	43.48	57.58	68.2	10.62	Peak

Vertical

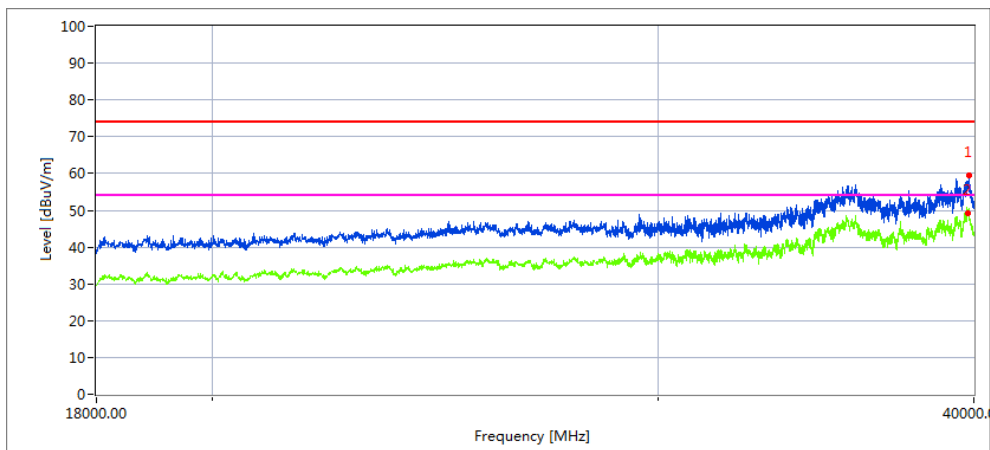

Frequency	Meter Reading	Cable loss	Antenna Factor	Preamp Factor	Emission Level	Limits	Margin	Remark
39821.763	37.97	20.1	44.1	43.22	58.95	68.2	9.25	Peak



2.2.10 Spurious Emission in Restricted Band 4.5GHz~5.150 GHz& 5.350GHz~5460GHz

EUT :	U231AZZ-LE1	Model Name. :	U231AZZ-LE1
Temperature :	20 °C	Relative Humidity :	48%
Pressure :	1010 hPa	Test Voltage :	DC 12V
Test Mode :	TX (5.2G)-802.11a 5150MHz~5250MHz,		

All the modulation modes have been tested, The report just record the worst data mode.

Frequency	Meter Reading	Cable Loss	Antenna Factor	Preamp Factor	Emission Level	Limits	Margin	Detector	Comment
(MHz)	(dBμV)	(dB)	dB/m	(dB)	(dBμV/m)	(dBμV/m)	(dB)	Type	
5.2G WIFI-802.11a Mode									
4500	54.17	5.2	35.6	44.2	50.77	74	-23.23	Pk	Horizontal
4500	45.17	5.2	35.6	44.2	41.77	54	-12.23	AV	Horizontal
4500	57.12	5.2	35.6	44.2	53.72	74	-20.28	Pk	Horizontal
4500	44.14	5.2	35.6	44.2	40.74	54	-13.26	AV	Horizontal
5150	68.13	5.36	35.66	44.22	64.93	74	-9.07	Pk	Horizontal
5150	46.55	5.36	35.66	44.22	43.35	54	-10.65	AV	Horizontal
5150	54.8	5.36	35.66	44.22	51.6	74	-22.4	Pk	Vertical
5150	50.47	5.36	35.66	44.22	47.27	54	-6.73	AV	Vertical
5350	63.46	5.68	35.68	44.22	60.6	74	-13.4	Pk	Vertical
5350	45.09	5.68	35.68	44.22	42.23	54	-11.77	AV	Vertical
5350	58.84	5.68	35.68	44.22	55.98	74	-18.02	Pk	Horizontal
5350	43.55	5.68	35.68	44.22	40.69	54	-13.31	AV	Horizontal

Note: (1) Emission Level= Antenna Factor + Cable Loss + Read Level - Preamp Factor

(2) "802.11a " mode is the worst mode. When PK value is lower than the Average value limit, average don't record.

EUT :	U231AZZ-LE1	Model Name. :	U231AZZ-LE1
Temperature :	20 °C	Relative Humidity :	48%
Pressure :	1010 hPa	Test Voltage :	DC 12V
Test Mode :	TX (5.3G)-802.11n20 5250MHz~5350MHz,		

All the modulation modes have been tested, The report just record the worst data mode.

Polar	Frequenc y	Meter Reading	Cabl e loss	Antenna Factor	Preamp Factor	Emission Level	Limits	Margi n	Detector Type
(H/V)	(MHz)	(dBuV)	(dB)	dB/m	(dB)	(dBuV/m)	(dBuV/m)	(dB)	
High Channel (5320 MHz)-Above 1G									
Vertical	5350.00	66.58	6.96	37.24	43.50	67.28	74.00	-6.72	Pk
Vertical	5350.00	44.57	7.07	37.24	43.50	45.38	54.00	-8.62	AV
Horizontal	5350.00	67.27	7.05	37.24	43.50	68.06	74.00	-5.94	Pk
Horizontal	5350.00	46.88	7.05	37.24	43.50	47.67	54.00	-6.33	AV

Note: (1) Emission Level= Antenna Factor + Cable Loss + Read Level - Preamp Factor

(2) "802.11n20 " mode is the worst mode. When PK value is lower than the Average value limit, average don't record.

EUT :	U231AZZ-LE1	Model Name. :	U231AZZ-LE1
Temperature :	20 °C	Relative Humidity :	48%
Pressure :	1010 hPa	Test Voltage :	DC 12V
Test Mode :	TX (5.6G)-802.11n20 5470MHz~5725MHz,		

All the modulation modes have been tested, The report just record the worst data mode.

Polar	Frequen cy	Meter Readin g	Cable loss	Antenn a Factor	Preamp Factor	Emission Level	Limits	Margin	Detecto r Type
(H/V)	(MHz)	(dBuV)	(dB)	dB/m	(dB)	(dBuV/m)	(dBuV/m)	(dB)	
Low Channel (5500 MHz)-Above 1G									
Vertical	5460.00	63.58	5.61	35.40	44.00	60.59	74.00	-13.41	Pk
Vertical	5460.00	46.55	5.76	35.40	44.00	43.71	54.00	-10.29	AV
Horizontal	5460.00	58.47	5.78	35.18	44.00	55.43	74.00	-18.57	Pk
Horizontal	5460.00	43.58	5.66	35.18	44.00	40.42	54.00	-13.58	AV

Note: (1) Emission Level= Antenna Factor + Cable Loss + Read Level - Preamp Factor

(2) "802.11n20 " mode is the worst mode. When PK value is lower than the Average value limit, average don't record.

### 3. POWER SPECTRAL DENSITY TEST

#### 3.1 APPLIED PROCEDURES / LIMIT

##### According to FCC §15.407(a)

For the band 5.15-5.25 GHz,

(i) For an outdoor access point operating in the band 5.15-5.25 GHz, the maximum power spectral density shall not exceed 17 dBm in any 1 megahertz band. If transmitting antennas of directional gain greater than 6 dBi are used, both the maximum conducted output power and the maximum power spectral density shall be reduced by the amount in dB that the directional gain of the antenna exceeds 6 dBi. The maximum e.i.r.p. at any elevation angle above 30 degrees as measured from the horizon must not exceed 125 mW (21 dBm).

(ii) For an indoor access point operating in the band 5.15-5.25 GHz, the maximum power spectral density shall not exceed 17 dBm in any 1 megahertz band. If transmitting antennas of directional gain greater than 6 dBi are used, both the maximum conducted output power and the maximum power spectral density shall be reduced by the amount in dB that the directional gain of the antenna exceeds 6 dBi.

(iii) For fixed point-to-point access points operating in the band 5.15-5.25 GHz, the maximum power spectral density shall not exceed 17 dBm in any 1 megahertz band. Fixed point-to-point U-NII devices may employ antennas with directional gain up to 23 dBi without any corresponding reduction in the maximum conducted output power or maximum power spectral density. For fixed point-to-point transmitters that employ a directional antenna gain greater than 23 dBi, a 1 dB reduction in maximum conducted output power and maximum power spectral density is required for each 1 dB of antenna gain in excess of 23 dBi. Fixed, point-to-point operations exclude the use of point-to-multipoint systems, omnidirectional applications, and multiple collocated transmitters transmitting the same information. The operator of the U-NII device, or if the equipment is professionally installed, the installer, is responsible for ensuring that systems employing high gain directional antennas are used exclusively for fixed, point-to-point operations.

(iv) For client devices in the 5.15-5.25 GHz band, the maximum power spectral density shall not exceed 11 dBm in any 1 megahertz band. If transmitting antennas of directional gain greater than 6 dBi are used, both the maximum conducted output power and the maximum power spectral density shall be reduced by the amount in dB that the directional gain of the antenna exceeds 6 dBi.

For the 5.25-5.35 GHz and 5.47-5.725 GHz bands, the maximum conducted output power over the frequency bands of operation shall not exceed the lesser of 250 mW or  $11 \text{ dBm} + 10 \log B$ , where B is the 26 dB emission bandwidth in megahertz. In addition, the maximum power spectral density shall not exceed 11 dBm in any 1 megahertz band. If transmitting antennas of directional gain greater than 6 dBi are used, both the maximum conducted output power and the maximum power spectral density shall be reduced by the amount in dB that the directional gain of the antenna exceeds 6 dBi.

For the band 5.725-5.85 GHz

(3) For the band 5.725-5.85 GHz, the maximum power spectral density shall not exceed 30 dBm in any 500-kHz band. If transmitting antennas of directional gain greater than 6 dBi are used, both the maximum conducted output power and the maximum power spectral density shall be reduced by the amount in dB that the directional gain of the antenna exceeds 6 dBi.

,

**3.2 TEST PROCEDURE**

For devices operating in the bands 5.15-5.25 GHz, 5.25-5.35 GHz, and 5.47-5.725 GHz, the above procedures make use of 1 MHz RBW to satisfy directly the 1 MHz reference bandwidth specified in § 15.407(a)(5). For devices operating in the band 5.725-5.85 GHz, the rules specify a measurement bandwidth of 500 kHz. Many spectrum analyzers do not have 500 kHz RBW, thus a narrower RBW may need to be used. The rules permit the use of a RBWs less than 1 MHz, or 500 kHz, “provided that the measured power is integrated over the full reference bandwidth” to show the total power over the specified measurement bandwidth (i.e., 1 MHz, or 500 kHz). If measurements are performed using a reduced resolution bandwidth (< 1 MHz, or < 500 kHz) and integrated over 1 MHz, or 500 KHz bandwidth, the following adjustments to the procedures apply:

- a) Set  $RBW \geq 1/T$ , where T is defined in section II.B.I.a).
- b) Set  $VBW \geq 3 RBW$ .
- c) If measurement bandwidth of Maximum PSD is specified in 500 kHz, add  $10\log(500\text{kHz}/RBW)$  to the measured result, whereas  $RBW (< 500 \text{ KHz})$  is the reduced resolution bandwidth of the spectrum analyzer set during measurement.
- d) If measurement bandwidth of Maximum PSD is specified in 1 MHz, add  $10\log(1\text{MHz}/RBW)$  to the measured result, whereas  $RBW (< 1 \text{ MHz})$  is the reduced resolution bandwidth of spectrum analyzer set during measurement.
- e) Care must be taken to ensure that the measurements are performed during a period of continuous transmission or are corrected upward for duty cycle.

Note: As a practical matter, it is recommended to use reduced RBW of 100 KHz for the sections 5.c) and 5.d) above, since  $RBW=100 \text{ KHz}$  is available on nearly all spectrum analyzers.

**3.3 DEVIATION FROM STANDARD**

No deviation.

**3.4 TEST SETUP**



**3.5 EUT OPERATION CONDITIONS**

The EUT tested system was configured as the statements of 2.1 Unless otherwise a special operating condition is specified in the follows during the testing.

**3.6 TEST RESULTS**

EUT :	U231AZZ-LE1	Model Name :	U231AZZ-LE1
Temperature :	26 °C	Relative Humidity :	54%
Pressure :	1015 hPa	Test Voltage :	DC 12V
Test Mode :	TX Frequency Band 1 (5150-5250MHz), Band 2A (5250-5350MHz), Band 2C (5470-5725MHz), Band 3 (5745-5825MHz)		

Test data reference attachment.

**4. 26DB & 99% EMISSION BANDWIDTH**

**4.1 APPLIED PROCEDURES / LIMIT**

The maximum power spectral density is measured as a conducted emission by direct connection of a calibrated test instrument to the equipment under test. If the device cannot be connected directly, alternative techniques acceptable to the Commission may be used. Measurements in the 5.725-5.85 GHz band are made over a reference bandwidth of 500 kHz or the 26 dB emission bandwidth of the device, whichever is less. Measurements in the 5.15-5.25 GHz, 5.25-5.35 GHz, and the 5.47-5.725 GHz bands are made over a bandwidth of 1 MHz or the 26 dB emission bandwidth of the device, whichever is less. A narrower resolution bandwidth can be used, provided that the measured power is integrated over the full reference bandwidth.

**4.2 TEST PROCEDURE**

- a) Set RBW = approximately 1% of the emission bandwidth.
- b) Set the VBW > RBW.
- c) Detector = Peak.
- d) Trace mode = max hold.
- e) Measure the maximum width of the emission that is 26 dB down from the maximum of the emission. Compare this with the RBW setting of the analyzer. Readjust RBW and repeat measurement as needed until the RBW/EBW ratio is approximately 1%.

The following procedure shall be used for measuring (99 %) power bandwidth:

- 1. Set center frequency to the nominal EUT channel center frequency.
- 2. Set span = 1.5 times to 5.0 times the OBW.
- 3. Set RBW = 1 % to 5 % of the OBW
- 4. Set  $VBW \geq 3 \cdot RBW$
- 5. Video averaging is not permitted. Where practical, a sample detection and single sweep mode shall be used. Otherwise, peak detection and max hold mode (until the trace stabilizes) shall be used.
- 6. Use the 99 % power bandwidth function of the instrument (if available).
- 7. If the instrument does not have a 99 % power bandwidth function, the trace data points are recovered and directly summed in power units. The recovered amplitude data points, beginning at the lowest frequency, are placed in a running sum until 0.5 % of the total is reached; that frequency is recorded as the lower frequency. The process is repeated until 99.5 % of the total is reached; that frequency is recorded as the upper frequency. The 99% occupied bandwidth is the difference between these two frequencies.

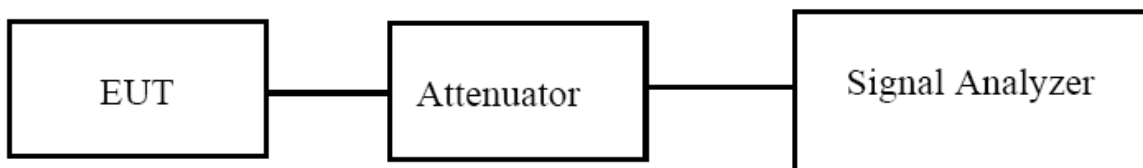

**4.3 EUT OPERATION CONDITIONS**

The EUT tested system was configured as the statements of 2.4 Unless otherwise a special operating condition is specified in the follows during the testing.

**4.4 TEST RESULTS**

EUT :	U231AZZ-LE1	Model Name :	U231AZZ-LE1
Temperature :	26 °C	Relative Humidity :	54%
Pressure :	1012 hPa	Test Voltage :	DC 12V
Test Mode :	TX Frequency Band 1 (5150-5250MHz), Band 2A (5250-5350MHz), Band 2C(5470-5725MHz), Band 3(5725-5850MHz)		

Test data reference attachment.



**5. MINIMUM 6 DB BANDWIDTH**

**5.1 APPLIED PROCEDURES / LIMIT**

**According to FCC §15.407(e)**

(e) Within the 5.725-5.85 GHz band, the minimum 6 dB bandwidth of U-NII devices shall be at least 500 kHz.

**5.2 TEST PROCEDURE**

Section 15.407(e) specifies the minimum 6 dB emission bandwidth of at least 500 KHz for the band 5.715-5.85 GHz. The following procedure shall be used for measuring this bandwidth:

- a) Set RBW = 100 kHz.
- b) Set the video bandwidth (VBW)  $\geq 3 \times$  RBW.
- c) Detector = Peak.
- d) Trace mode = max hold.
- e) Sweep = auto couple.
- f) Allow the trace to stabilize.
- g) Measure the maximum width of the emission that is constrained by the frequencies associated with the two outermost amplitude points (upper and lower frequencies) that are attenuated by 6 dB relative to the maximum level measured in the fundamental emission.

**5.3 DEVIATION FROM STANDARD**

No deviation.

**5.4 TEST SETUP**

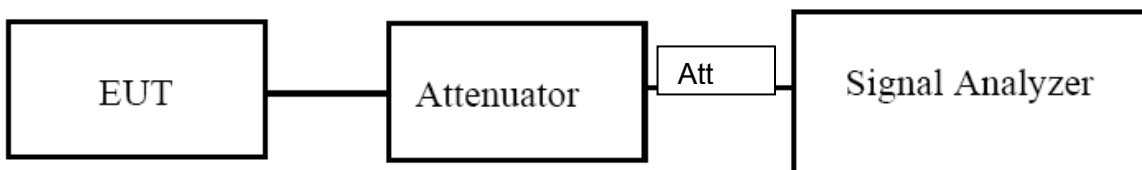

**5.5 EUT OPERATION CONDITIONS**

The EUT tested system was configured as the statements of 2.4 Unless otherwise a special operating condition is specified in the follows during the testing.

**5.6 TEST RESULTS**

EUT :	U231AZZ-LE1	Model Name :	U231AZZ-LE1
Temperature :	26 °C	Relative Humidity :	54%
Pressure :	1012 hPa	Test Voltage :	DC 12V
Test Mode :	TX (5G) Mode Frequency Band 3 (5725-5850MHz)		

Test data reference attachment.

**6. MAXIMUM CONDUCTED OUTPUT POWER**

**6.1 PPLIED PROCEDURES / LIMIT**

**According to FCC §15.407**

The maximum conducted output power should not exceed:

Frequency Band(MHz)	Limit
5150~5250	250mW
5250~5350	250 mW or 11 dBm + 10 log B Note: The limit is the smaller of the two, "B" represents -26dB bandwidth.
5470~5725	250 mW or 11 dBm + 10 log B Note: The limit is the smaller of the two, "B" represents -26dB bandwidth.
5725~5850	1W

**6.2 TEST PROCEDURE**

- Method PM is Measurement using an RF average power meter. The procedure for this method is as follows:
  - a) Measurements may be performed using a wideband RF power meter with a thermocouple detector or equivalent if all of the following conditions are satisfied:
    - 1) The EUT is configured to transmit continuously, or to transmit with a constant duty cycle.
    - 2) At all times when the EUT is transmitting, it shall be transmitting at its maximum power control level.
    - 3) The integration period of the power meter exceeds the repetition period of the transmitted signal by at least a factor of five.
  - b) If the transmitter does not transmit continuously, measure the duty cycle D of the transmitter output signal as described in 12.2.
  - c) Measure the average power of the transmitter. This measurement is an average over both the ON and OFF periods of the transmitter.
  - d) Adjust the measurement in dBm by adding  $[10 \log (1 / D)]$ , where D is the duty cycle {e.g.,  $[10 \log (1 / 0.25)]$ , if the duty cycle is 25%}.

6.3 DEVIATION FROM STANDARD

No deviation.

6.4 TEST SETUP

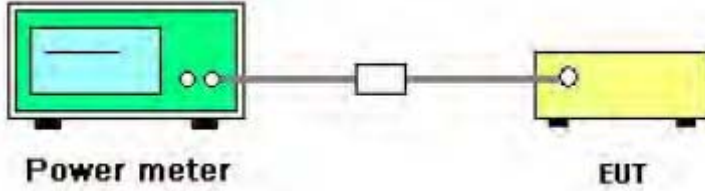

6.5 EUT OPERATION CONDITIONS

The EUT tested system was configured as the statements of 2.4 Unless otherwise a special operating condition is specified in the follows during the testing.

**6.2 TEST RESULTS**

EUT :	U231AZZ-LE1	Model Name :	U231AZZ-LE1
Temperature :	26 °C	Relative Humidity :	54%
Pressure :	1012 hPa	Test Voltage :	DC 12V
Test Mode :	TX (5G) Mode Frequency Band 1 (5150-5250MHz), Band 2A (5250-5350MHz) Band 2C, (5470-5725MHz), Band 3 (5725-5850MHz)		

Test data reference attachment.

## 7. OUT OF BAND EMISSIONS

### 7.1 APPLICABLE STANDARD

#### According to FCC §15.407(b)

Undesirable emission limits. Except as shown in paragraph (b)(7) of this section, the maximum emissions outside of the frequency bands of operation shall be attenuated in accordance with the following limits:

- (1) For transmitters operating in the 5.15-5.25 GHz band: All emissions outside of the 5.15-5.35 GHz band shall not exceed an e.i.r.p. of  $-27$  dBm/MHz.
- (2) For transmitters operating in the 5.25-5.35 GHz band: All emissions outside of the 5.15-5.35 GHz band shall not exceed an e.i.r.p. of  $-27$  dBm/MHz.
- (3) For transmitters operating in the 5.47-5.725 GHz band: All emissions outside of the 5.47-5.725 GHz band shall not exceed an e.i.r.p. of  $-27$  dBm/MHz.
- (4) For transmitters operating in the 5.725-5.85 GHz band: All emissions within the frequency range from the band edge to 10 MHz above or below the band edge shall not exceed an e.i.r.p. of  $-17$  dBm/MHz; for frequencies 10 MHz or greater above or below the band edge, emissions shall not exceed an e.i.r.p. of  $-27$  dBm/MHz.

### 7.2 TEST PROCEDURE

1. Check the calibration of the measuring instrument using either an internal calibrator or a known signal from an external generator.
2. Position the EUT without connection to measurement instrument. Turn on the EUT and connect its antenna terminal to measurement instrument via a low loss cable. Then set it to any one measured frequency within its operating range, and make sure the instrument is operated in its linear range.
3. Set RBW of spectrum analyzer to 1 MHz with a convenient frequency span.
4. Measure the highest amplitude appearing on spectral display and set it as a reference level. Plot the graph with marking the highest point and edge frequency.
5. Repeat above procedures until all measured frequencies were complete.

### 7.3 DEVIATION FROM STANDARD

No deviation.

### 7.4 TEST SETUP

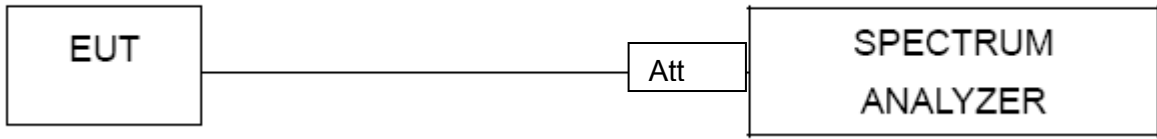

**7.5 EUT OPERATION CONDITIONS**

The EUT tested system was configured as the statements of 2.4 Unless otherwise a special operating condition is specified in the follows during the testing.

**7.6 TEST RESULTS**

EUT :	U231AZZ-LE1	Model Name :	U231AZZ-LE1
Temperature :	26 °C	Relative Humidity :	54%
Pressure :	1012 hPa	Test Voltage :	DC 12V

Test data reference attachment.



## 8. Frequency Stability Measurement

### 8.1 LIMIT

Manufactures of U-NII devices are responsible for ensuring frequency stability such that an emission is maintained within the band of operation under all conditions of normal operation as specified in the user's manual.

### 8.2 TEST PROCEDURES

1. The transmitter output (antenna port) was connected to the spectrum analyzer.
2. EUT have transmitted absence of modulation signal and fixed channelize.
3. Set the spectrum analyzer span to view the entire absence of modulation emissions bandwidth.
4. Set RBW = 10 kHz, VBW = 10 kHz with peak detector and maxhold settings.
5.  $f_c$  is declaring of channel frequency. Then the frequency error formula is  $(f_c - f) / f_c \times 10^6$  ppm and the limit is less than  $\pm 20$  ppm (IEEE 802.11 specification).
6. The test extreme voltage is to change the primary supply voltage from 85 to 115 percent of the nominal value
7. Extreme temperature is  $-20^{\circ}\text{C} \sim 70^{\circ}\text{C}$ .

### 8.3 TEST SETUP LAYOUT

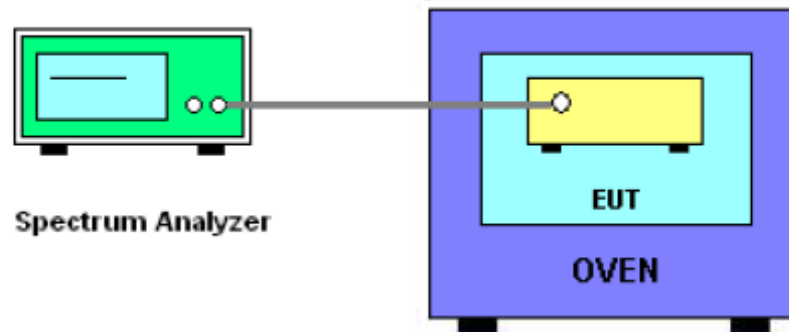

### 8.4 EUT OPERATION DURING TEST

1. The EUT was programmed to be in continuously un-modulation transmitting mode.
2. The module has two antennas, and the worst data is Antenna 1, only shown Antenna 1 Plot.

8.5 TEST RESULTS

EUT :	U231AZZ-LE1	Model Name. :	U231AZZ-LE1
Temperature :	25 °C	Relative Humidity :	56%
Pressure :	1012 hPa	Test Voltage :	DC 12V
Test Mode :	TX Frequency Band I (5150-5250MHz)		

Voltage vs. Frequency Stability

TEST CONDITIONS				Reference Frequency: 5180MHz			
				f	fc	Max. Deviation (MHz)	Max. Deviation (ppm)
T nom (°C)	20	V nom (V)	12.00	5180.0375	5180	0.0375	-7.2475
		V max (V)	13.80	5180.0738	5180	0.0738	-14.2525
		V min (V)	10.20	5180.0456	5180	0.0456	-8.7943
Limits				Within 5150-5250MHz			
Result				Complies			

Temperature vs. Frequency Stability

TEST CONDITIONS				Reference Frequency: 5180MHz			
				f	fc	Max. Deviation (MHz)	Max. Deviation (ppm)
V nom (V)	12	T (°C)	-20	5180.0318	5180	0.0318	-6.1344
		T (°C)	-10	5180.0018	5180	0.0018	-0.3392
		T (°C)	0	5180.0685	5180	0.0685	-13.2193
		T (°C)	10	5180.0386	5180	0.0386	-7.4453
		T (°C)	20	5180.0286	5180	0.0286	-5.5293
		T (°C)	30	5180.0604	5180	0.0604	-11.6634
		T (°C)	40	5180.0087	5180	0.0087	-1.6851
		T (°C)	50	5180.0648	5180	0.0648	-12.5084
		T (°C)	60	5180.0360	5180	0.0360	-6.9562
		T (°C)	70	5180.0375	5180	0.0375	-7.2372
Limits				Within 5150-5250MHz			
Result				Complies			

Voltage vs. Frequency Stability

TEST CONDITIONS				Reference Frequency: 5200MHz			
				f	fc	Max. Deviation (MHz)	Max. Deviation (ppm)
T nom (°C)	20	V nom (V)	12.00	5200.0582	5200	0.0582	-11.1940
		V max (V)	13.80	5200.0656	5200	0.0656	-12.6112
		V min (V)	10.20	5200.0133	5200	0.0133	-2.5594
Limits				Within 5150-5250MHz			
Result				Complies			

Temperature vs. Frequency Stability

TEST CONDITIONS				Reference Frequency: 5200MHz			
				f	fc	Max. Deviation (MHz)	Max. Deviation (ppm)
V nom (V)	12	T (°C)	-20	5200.0074	5200	0.0074	-1.4254
		T (°C)	-10	5200.0143	5200	0.0143	-2.7476
		T (°C)	0	5200.0538	5200	0.0538	-10.3382
		T (°C)	10	5200.0148	5200	0.0148	-2.8422
		T (°C)	20	5200.0757	5200	0.0757	-14.5613
		T (°C)	30	5200.0183	5200	0.0183	-3.5266
		T (°C)	40	5200.0466	5200	0.0466	-8.9671
		T (°C)	50	5200.0325	5200	0.0325	-6.2490
		T (°C)	60	5200.0764	5200	0.0764	-14.6947
		T (°C)	70	5200.0504	5200	0.0504	-9.6844
Limits				Within 5150-5250MHz			
Result				Complies			

Voltage vs. Frequency Stability

TEST CONDITIONS				Reference Frequency: 5240MHz			
				f	fc	Max. Deviation (MHz)	Max. Deviation (ppm)
T nom (°C)	20	V nom (V)	12.00	5240.0454	5240	0.0454	-8.6733
		V max (V)	13.80	5240.0679	5240	0.0679	-12.9563
		V min (V)	10.20	5240.0681	5240	0.0681	-12.9978
Limits				Within 5150-5250MHz			
Result				Complies			

Temperature vs. Frequency Stability

TEST CONDITIONS				Reference Frequency: 5240MHz			
				f	fc	Max. Deviation (MHz)	Max. Deviation (ppm)
V nom (V)	12	T (°C)	-20	5240.0761	5240	0.0761	-14.5217
		T (°C)	-10	5240.0722	5240	0.0722	-13.7747
		T (°C)	0	5240.0490	5240	0.0490	-9.3439
		T (°C)	10	5240.0073	5240	0.0073	-1.3977
		T (°C)	20	5240.0196	5240	0.0196	-3.7327
		T (°C)	30	5240.0117	5240	0.0117	-2.2313
		T (°C)	40	5240.0255	5240	0.0255	-4.8747
		T (°C)	50	5240.0541	5240	0.0541	-10.3194
		T (°C)	60	5240.0455	5240	0.0455	-8.6827
		T (°C)	70	5240.0587	5240	0.0587	-11.2095
Limits				Within 5150-5250MHz			
Result				Complies			

EUT :	U231AZZ-LE1	Model Name. :	U231AZZ-LE1
Temperature :	25 °C	Relative Humidity :	56%
Pressure :	1012 hPa	Test Voltage :	DC 12V
Test Mode :	TX Frequency Band 2A (5250-5350MHz)		

Voltage vs. Frequency Stability

TEST CONDITIONS				Reference Frequency: 5260MHz			
				f	fc	Max. Deviation (MHz)	Max. Deviation (ppm)
T nom (°C)	20	V nom (V)	12.00	5260.01491	5260	0.01491	-2.8346
		V max (V)	13.80	5260.01311	5260	0.01311	-2.4924
		V min (V)	10.20	5260.01851	5260	0.01851	-3.5190
Limits				Within 5250-5350MHz			
Result				Complies			

Temperature vs. Frequency Stability

TEST CONDITIONS				Reference Frequency: 5260MHz			
				f	fc	Max. Deviation (MHz)	Max. Deviation (ppm)
V nom (V)	12	T (°C)	-20	5260.00421	5260	0.00421	-0.8004
		T (°C)	-10	5260.02181	5260	0.02181	-4.1464
		T (°C)	0	5260.00551	5260	0.00551	-1.0475
		T (°C)	10	5260.01361	5260	0.01361	-2.5875
		T (°C)	20	5260.00491	5260	0.00491	-0.9335
		T (°C)	30	5260.00691	5260	0.00691	-1.3137
		T (°C)	40	5260.01341	5260	0.01341	-2.5494
		T (°C)	50	5260.00521	5260	0.00521	-0.9905
		T (°C)	60	5260.02151	5260	0.02151	-4.0894
		T (°C)	70	5260.01991	5260	0.01991	-3.7852
Limits				Within 5250-5350MHz			
Result				Complies			

Voltage vs. Frequency Stability

TEST CONDITIONS				Reference Frequency: 5280MHz			
				f	fc	Max. Deviation (MHz)	Max. Deviation (ppm)
T nom (°C)	20	V nom (V)	12.00	5280.01111	5280	0.01111	-2.1042
		V max (V)	13.80	5280.01091	5280	0.01091	-2.0663
		V min (V)	10.20	5280.01211	5280	0.01211	-2.2936
Limits				Within 5250-5350MHz			
Result				Complies			

Temperature vs. Frequency Stability

TEST CONDITIONS				Reference Frequency: 5280MHz			
				f	fc	Max. Deviation (MHz)	Max. Deviation (ppm)
V nom (V)	12	T (°C)	-20	5280.01551	5280	0.01551	-2.9375
		T (°C)	-10	5280.01421	5280	0.01421	-2.6913
		T (°C)	0	5280.00801	5280	0.00801	-1.5170
		T (°C)	10	5280.00891	5280	0.00891	-1.6875
		T (°C)	20	5280.00901	5280	0.00901	-1.7064
		T (°C)	30	5280.00701	5280	0.00701	-1.3277
		T (°C)	40	5280.01551	5280	0.01551	-2.9375
		T (°C)	50	5280.00961	5280	0.00961	-1.8201
		T (°C)	60	5280.01141	5280	0.01141	-2.1610
		T (°C)	70	5280.00601	5280	0.00601	-1.1383
Limits				Within 5250-5350MHz			
Result				Complies			

Voltage vs. Frequency Stability

TEST CONDITIONS				Reference Frequency: 5320MHz			
				f	fc	Max. Deviation (MHz)	Max. Deviation (ppm)
T nom (°C)	20	V nom (V)	12.00	5320.02251	5320	0.02251	-4.2312
		V max (V)	13.80	5320.01771	5320	0.01771	-3.3289
		V min (V)	10.20	5320.01541	5320	0.01541	-2.8966
Limits				Within 5250-5350MHz			
Result				Complies			

Temperature vs. Frequency Stability

TEST CONDITIONS				Reference Frequency: 5320MHz			
				f	fc	Max. Deviation (MHz)	Max. Deviation (ppm)
V nom (V)	12	T (°C)	-20	5320.01071	5320	0.01071	-2.0132
		T (°C)	-10	5320.00931	5320	0.00931	-1.7500
		T (°C)	0	5320.01171	5320	0.01171	-2.2011
		T (°C)	10	5320.00491	5320	0.00491	-0.9229
		T (°C)	20	5320.00451	5320	0.00451	-0.8477
		T (°C)	30	5320.01041	5320	0.01041	-1.9568
		T (°C)	40	5320.02241	5320	0.02241	-4.2124
		T (°C)	50	5320.01381	5320	0.01381	-2.5959
		T (°C)	60	5320.00681	5320	0.00681	-1.2801
		T (°C)	70	5320.02051	5320	0.02051	-3.8553
Limits				Within 5250-5350MHz			
Result				Complies			

EUT :	U231AZZ-LE1	Model Name. :	U231AZZ-LE1
Temperature :	25 °C	Relative Humidity :	56%
Pressure :	1012 hPa	Test Voltage :	DC 12V
Test Mode :	TX Frequency Band 2C (5470-5725MHz)		

Voltage vs. Frequency Stability

TEST CONDITIONS				Reference Frequency: 5500MHz			
				f	fc	Max. Deviation (MHz)	Max. Deviation (ppm)
T nom (°C)	20	V nom (V)	12.00	5500.00549	5500	0.00549	-0.9982
		V max (V)	13.80	5500.00386	5500	0.00386	-0.7018
		V min (V)	10.20	5500.00155	5500	0.00155	-0.2818
Limits				Within 5470-5725MHz			
Result				Complies			

Temperature vs. Frequency Stability

TEST CONDITIONS				Reference Frequency: 5500MHz			
				f	fc	Max. Deviation (MHz)	Max. Deviation (ppm)
V nom (V)	12	T (°C)	-20	5500.00578	5500	0.00578	-1.0509
		T (°C)	-10	5500.01269	5500	0.01269	-2.3073
		T (°C)	0	5500.00629	5500	0.00629	-1.1436
		T (°C)	10	5500.00642	5500	0.00642	-1.1673
		T (°C)	20	5500.00867	5500	0.00867	-1.5764
		T (°C)	30	5500.00569	5500	0.00569	-1.0345
		T (°C)	40	5500.00506	5500	0.00506	-0.9200
		T (°C)	50	5500.00297	5500	0.00297	-0.5400
		T (°C)	60	5500.00566	5500	0.00566	-1.0291
		T (°C)	70	5500.00837	5500	0.00837	-1.5218
Limits				Within 5470-5725MHz			
Result				Complies			



Voltage vs. Frequency Stability

TEST CONDITIONS				Reference Frequency: 5600MHz			
				f	fc	Max. Deviation (MHz)	Max. Deviation (ppm)
T nom (°C)	20	V nom (V)	12.00	5600.00696	5600	0.00696	-1.2429
		V max (V)	13.80	5600.00875	5600	0.00875	-1.5625
		V min (V)	10.20	5600.00812	5600	0.00812	-1.4500
Limits				Within 5470-5725MHz			
Result				Complies			

Temperature vs. Frequency Stability

TEST CONDITIONS				Reference Frequency: 5600MHz			
				f	fc	Max. Deviation (MHz)	Max. Deviation (ppm)
V nom (V)	12	T (°C)	-20	5600.00977	5600	0.00977	-1.7446
		T (°C)	-10	5600.00354	5600	0.00354	-0.6321
		T (°C)	0	5600.00335	5600	0.00335	-0.5982
		T (°C)	10	5600.00804	5600	0.00804	-1.4357
		T (°C)	20	5600.01056	5600	0.01056	-1.8857
		T (°C)	30	5600.00423	5600	0.00423	-0.7554
		T (°C)	40	5600.00736	5600	0.00736	-1.3143
		T (°C)	50	5600.00753	5600	0.00753	-1.3446
		T (°C)	60	5600.01117	5600	0.01117	-1.9946
		T (°C)	70	5600.00552	5600	0.00552	-0.9857
Limits				Within 5470-5725MHz			
Result				Complies			

Voltage vs. Frequency Stability

TEST CONDITIONS				Reference Frequency: 5700MHz			
				f	fc	Max. Deviation (MHz)	Max. Deviation (ppm)
T nom (°C)	20	V nom (V)	12.00	5700.00479	5700	0.00479	-0.8404
		V max (V)	13.80	5700.00646	5700	0.00646	-1.1333
		V min (V)	10.20	5700.00828	5700	0.00828	-1.4526
Limits				Within 5470-5725MHz			
Result				Complies			

Temperature vs. Frequency Stability

TEST CONDITIONS				Reference Frequency: 5700MHz			
				f	fc	Max. Deviation (MHz)	Max. Deviation (ppm)
V nom (V)	12	T (°C)	-20	5700.00968	5700	0.00968	-1.6982
		T (°C)	-10	5700.00464	5700	0.00464	-0.8140
		T (°C)	0	5700.00349	5700	0.00349	-0.6123
		T (°C)	10	5700.00233	5700	0.00233	-0.4088
		T (°C)	20	5700.00830	5700	0.00830	-1.4561
		T (°C)	30	5700.00993	5700	0.00993	-1.7421
		T (°C)	40	5700.00617	5700	0.00617	-1.0825
		T (°C)	50	5700.00199	5700	0.00199	-0.3491
		T (°C)	60	5700.00424	5700	0.00424	-0.7439
		T (°C)	70	5700.00419	5700	0.00419	-0.7351
Limits				Within 5470-5725MHz			
Result				Complies			

EUT :	U231AZZ-LE1	Model Name. :	U231AZZ-LE1
Temperature :	25 °C	Relative Humidity :	56%
Pressure :	1012 hPa	Test Voltage :	DC 12V
Test Mode :	TX Frequency(5745-5850MHz)		

Voltage vs. Frequency Stability

TEST CONDITIONS				Reference Frequency: 5745MHz			
				f	fc	Max. Deviation (MHz)	Max. Deviation (ppm)
T nom (°C)	20	V nom (V)	12.00	5745.0631	5745	0.06314	-10.9908
		V max (V)	13.80	5745.0703	5745	0.07030	-12.2371
		V min (V)	10.20	5745.0650	5745	0.06498	-11.3112
Limits				Within 5745-5850MHz			
Result				Complies			

Temperature vs. Frequency Stability

TEST CONDITIONS				Reference Frequency: 5745MHz			
				f	fc	Max. Deviation (MHz)	Max. Deviation (ppm)
V nom (V)	12	T (°C)	-20	5745.0501	5745	0.05013	-8.7255
		T (°C)	-10	5745.0504	5745	0.05042	-8.7763
		T (°C)	0	5745.0023	5745	0.00231	-0.4013
		T (°C)	10	5745.0797	5745	0.07973	-13.8777
		T (°C)	20	5745.0774	5745	0.07739	-13.4700
		T (°C)	30	5745.0763	5745	0.07635	-13.2890
		T (°C)	40	5745.0530	5745	0.05296	-9.2189
		T (°C)	50	5745.0503	5745	0.05034	-8.7632
		T (°C)	60	5745.0441	5745	0.04407	-7.6709
		T (°C)	70	5745.0295	5745	0.02950	-5.1347
Limits				Within 5745-5850MHz			
Result				Complies			

Voltage vs. Frequency Stability

TEST CONDITIONS				Reference Frequency: 5785MHz			
				f	fc	Max. Deviation (MHz)	Max. Deviation (ppm)
T nom (°C)	20	V nom (V)	12.00	5785.0036	5785	0.00363	-0.6280
		V max (V)	13.80	5785.0701	5785	0.07014	-12.1250
		V min (V)	10.20	5785.0292	5785	0.02918	-5.0439
Limits				Within 5745-5850MHz			
Result				Complies			

Temperature vs. Frequency Stability

TEST CONDITIONS				Reference Frequency: 5785MHz			
				f	fc	Max. Deviation (MHz)	Max. Deviation (ppm)
V nom (V)	12	T (°C)	-20	5785.0333	5785	0.03326	-5.7502
		T (°C)	-10	5785.0182	5785	0.01816	-3.1391
		T (°C)	0	5785.0398	5785	0.03976	-6.8733
		T (°C)	10	5785.0635	5785	0.06350	-10.9763
		T (°C)	20	5785.0416	5785	0.04164	-7.1977
		T (°C)	30	5785.0743	5785	0.07427	-12.8381
		T (°C)	40	5785.0423	5785	0.04226	-7.3053
		T (°C)	50	5785.0711	5785	0.07107	-12.2848
		T (°C)	60	5785.0622	5785	0.06225	-10.7604
T (°C)	70	5785.0721	5785	0.07210	-12.4637		
Limits				Within 5745-5850MHz			
Result				Complies			

Voltage vs. Frequency Stability

TEST CONDITIONS				Reference Frequency: 5825MHz			
				f	fc	Max. Deviation (MHz)	Max. Deviation (ppm)
T nom (°C)	20	V nom (V)	12.00	5825.0404	5825	0.04043	-6.9407
		V max (V)	13.80	5825.0614	5825	0.06142	-10.5438
		V min (V)	10.20	5825.0188	5825	0.01876	-3.2213
Limits				Within 5745-5850MHz			
Result				Complies			

Temperature vs. Frequency Stability

TEST CONDITIONS				Reference Frequency: 5825MHz			
				f	fc	Max. Deviation (MHz)	Max. Deviation (ppm)
V nom (V)	12	T (°C)	-20	5825.0339	5825	0.03395	-5.8280
		T (°C)	-10	5825.0138	5825	0.01385	-2.3770
		T (°C)	0	5825.0681	5825	0.06812	-11.6943
		T (°C)	10	5825.0657	5825	0.06570	-11.2797
		T (°C)	20	5825.0499	5825	0.04993	-8.5709
		T (°C)	30	5825.0499	5825	0.04991	-8.5684
		T (°C)	40	5825.0397	5825	0.03970	-6.8159
		T (°C)	50	5825.0669	5825	0.06691	-11.4872
		T (°C)	60	5825.0452	5825	0.04518	-7.7554
		T (°C)	70	5825.0218	5825	0.02183	-3.7485
Limits				Within 5745-5850MHz			
Result				Complies			

Note: antenna 1 is the worst case.

## 9. DYNAMIC FREQUENCY SELECTION(DFS)

### 9.1 APPLICABILITY OF DFS REQUIREMENTS

EUT is client and operates as client without radar detection function.

Table 1: Applicability of DFS Requirements Prior to Use of a Channel

Requirement	Operational Mode		
	Master	Client Without Radar Detection	Client With Radar Detection
Non-Occupancy Period	Yes	Not required	Yes
DFS Detection Threshold	Yes	Not required	Yes
Channel Availability Check Time	Yes	Not required	Not required
U-NII Detection Bandwidth	Yes	Not required	Yes

Table 2: Applicability of DFS requirements during normal operation

Requirement	Operational Mode		
	Master	Client Without Radar Detection	Client With Radar Detection
DFS Detection Threshold	Yes	Not required	Yes
Channel Closing Transmission Time	Yes	Yes	Yes
Channel Move Time	Yes	Yes	Yes
U-NII Detection Bandwidth	Yes	Not required	Yes
Client Beacon Test	N/A	Yes	Yes

Additional requirements for devices with multiple bandwidth modes	Operational Mode	
	Master or Client With Radar Detection	Client Without Radar Detection
U-NII Detection Bandwidth and Statistical Performance Check	All BW modes must be tested	Not required
Channel Move Time and Channel Closing Transmission Time	Test using widest BW mode available	Test using the widest BW mode available for the link
All other tests	Any single BW mode	Not required
<p><b>Note</b> Frequencies selected for statistical performance check (Section 7.8.4) should include several frequencies within the radar detection bandwidth and frequencies near the edge of the radar detection bandwidth. For 802.11 devices it is suggested to select frequencies in each of the bonded 20 MHz channels and the channel center frequency.</p>		

### 9.2 INTERFERENCE THRESHOLD VALUES, MASTER OR CLIENT INCORPORATING IN-SERVICE MONITORING

Maximum Transmit Power	Value (see notes 1, 2, and 3)
EIRP $\geq$ 200 milliwatt	-64 dBm
EIRP < 200 milliwatt and power spectral density < 10 dBm/MHz	-62 dBm
EIRP < 200 milliwatt that do not meet the power spectral density requirement	-64 dBm
<p><b>Note 1:</b> This is the level at the input of the receiver assuming a 0 dBi receive antenna.</p> <p><b>Note 2:</b> Throughout these test procedures an additional 1 dB has been added to the amplitude of the test transmission waveforms to account for variations in measurement equipment. This will ensure that the test signal is at or above the detection threshold level to trigger a DFS response.</p> <p><b>Note 3:</b> EIRP is based on the highest antenna gain.</p>	

**9.3 DFS RESPONSE REQUIREMENT VALUES**

Parameter	Value
Non-occupancy period	Minimum 30 minutes
Channel Availability Check Time	60 seconds
Channel Move Time	10 seconds See Note 1.
Channel Closing Transmission Time	200 milliseconds + an aggregate of 60 milliseconds over remaining 10 second period. See Notes 1 and 2.
U-NII Detection Bandwidth	Minimum 100% of the 99% power bandwidth See Note 3.

**Note 1:** The instant that the Channel Move Time and the Channel Closing Transmission Time begins is as follows:

- For the Short pulse radar Test Signals this instant is the end of the Burst.
- For the Frequency Hopping radar Test Signal, this instant is the end of the last radar Burst generated.
- For the Long Pulse radar Test Signal this instant is the end of the 12 second period defining the radar transmission.

**Note 2:** The Channel Closing Transmission Time is comprised of 200 milliseconds starting at the beginning of the Channel Move Time plus any additional intermittent control signals required to facilitate Channel changes (an aggregate of 60 milliseconds) during the remainder of the 10 second period. The aggregate duration of control signals will not count quiet periods in between transmissions.

**Note 3:** During the U-NII Detection Bandwidth detection test, radar type 0 is used and for each frequency step the minimum percentage of detection is 90%. Measurements are performed with no data traffic.

**9.4 SHORT PULSE RADAR TEST WAVEFORMS**

As the EUT is a Client Device with no Radar Detection, only one type radar pulse is required for the testing. Radar Pulse type 0 was used in the evaluation of the Client device for the purpose of measuring the Channel Move Time and the Channel Closing Transmission Time.

Radar Type	Pulse Width (µsec)	PRI (µsec)	Number of Pulses	Minimum Percentage of Successful Detection	Minimum Trials
0	1	1428	18	60%	30
1	1	Test A Test B	Roundup $\left( \frac{1}{360} \cdot \frac{19 \cdot 10^6}{PRI_{min}} \right)$	60%	30
2	1-5	150-230	23-29	60%	30
3	6-10	200-500	16-18	60%	30
4	11-20	200-500	12-16	60%	30
Aggregate (Radar Types 1-4)				80%	120

Test A: 15 unique PRI values randomly selected from the list of 23 PRI values in Table 5a  
 Test B: 15 unique PRI values randomly selected within the range of 518-3066 µsec, with a minimum increment of 1 µsec, excluding PRI values selected in Test A

A minimum of 30 unique waveforms are required for each of the short pulse radar types 2 through 4. For short pulse radar type 1, the same waveform is used a minimum of 30 times. If more than 30 waveforms are used for short pulse radar types 2 through 4, then each additional waveform must also be unique and not repeated from the previous waveforms.  
 If more than 30 waveforms are used for Short Pulse Radar Type 1, then each additional waveform is generated with Test B and must also be unique and not repeated from the previous waveforms in Tests A or B. The aggregate is the average of the percentage of successful detections of short pulse radar types 1-4.

**9.5 CALIBRATION SETUP AND DFS TEST RESULTS**

Radar Waveform Calibration Procedure

- 1) A 50 ohm load is connected in place of the spectrum analyzer, and the spectrum analyzer is connected to place of the master
- 2) The interference Radar Detection Threshold Level is  $-62\text{dBm} - 5.1\text{dBi} + 1\text{dB} = -66.1\text{dBm}$  that had been taken into account the output power range and antenna gain.
- 3) The following equipment setup was used to calibrate the conducted radar waveform. A vector signal generator was utilized to establish the test signal level for radar type 0. During this process there were no transmissions by either the master or client device. The spectrum analyzer was switched to the zero spans (time domain) at the frequency of the radar waveform generator. Peak detection was used. The spectrum analyzer resolution bandwidth (RBW) and video bandwidth (VBW) were set to 3 MHz. The spectrum analyzer had offset  $-1.0\text{dB}$  to compensate RF cable loss  $1.0\text{dB}$ .
- 4) The vector signal generator amplitude was set so that the power level measured at the spectrum analyzer was  $-62\text{dBm} - 5.1\text{dBi} + 1\text{dB} = -66.1\text{dBm}$ . Capture the spectrum analyzer plots on short pulse radar waveform.

**9.6 CONDUCTED CALIBRATION SETUP**

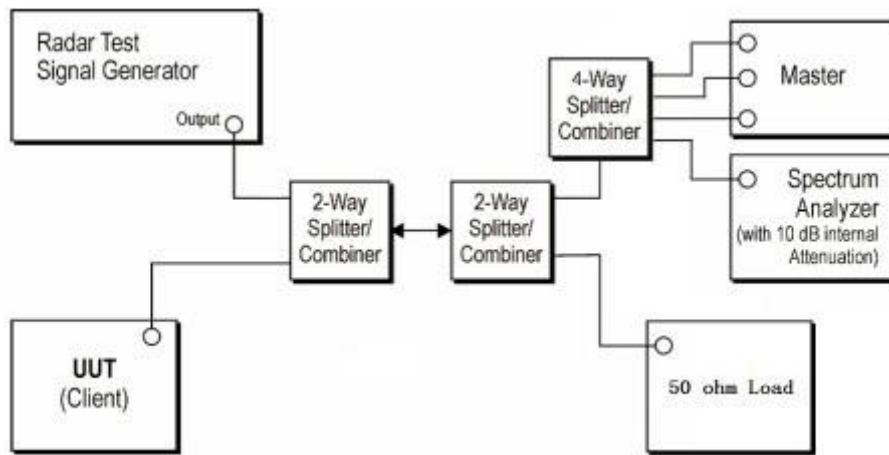

Wireless AP	Manufacturer	LINKSYS LLC
	Model NO.	WRT32X
	FCC ID	Q87-WRT3200ACM



### 9.7 RADAR WAVEFORM CALIBRATION RESULT

Test data reference attachment.

**9.8 IN-SERVICE MONITORING: CHANNEL MOVE TIME, CHANNEL CLOSING TRANSMISSION TIME AND NON-OCCUPANCY PERIOD**

**TEST CONFIGURATION:**

Setup for Client with injection at the Master

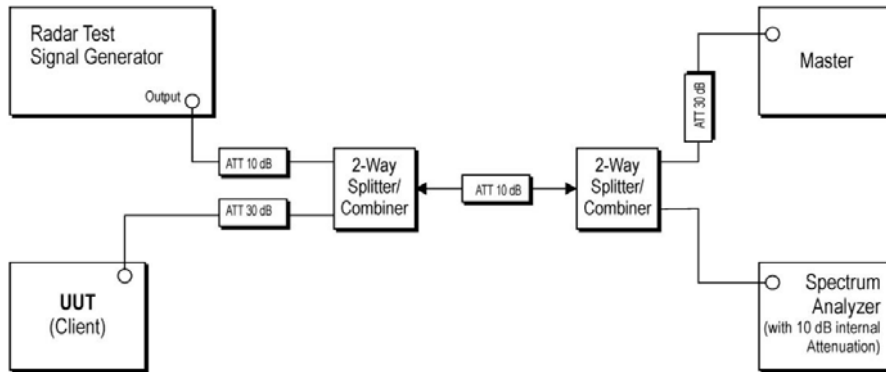

**TEST PROCEDURE:**

1. The radar pulse generator is setup to provide a pulse at frequency that the master and client are operating. A type 0 radar pulse with a 1us pulse width and a 1428us PRI is used for the testing.
2. The vector signal generator is adjusted to provide the radar burst (18 pulses) at the level of approximately -61dBm at the antenna port of the master device
3. A trigger is provided from the pulse generator to the DFS monitoring system in order to capture the traffic and the occurrence of the radar pulse.
4. EUT will associate with the master at channel. The file "iperf.exe" specified by the FCC is Streamed from the PC 2 through the master and the client device to the PC 1 and played in full motion video using Media Player Classic Ver. 6.4.8.6 in order to properly load the network for the entire period of the test.
5. When radar burst with a level equal to the DFS Detection Threshold +1dB is generated on the operating channel of the U-NII device. At time T0 the radar waveform generator sends a burst of pulse of the radar waveform at Detection Threshold +1dB.
6. Observe the transmissions of the EUT at the end of the radar Burst on the Operating Channel Measure and record the transmissions from the UUT during the observation time (Channel Move Time). One 15 seconds plot is reported for the Short Pulse Radar Type 0. The plot for the Short Pulse Radar Types start at the end of the radar burst. The Channel Move Time will be calculated based on the zoom In 600ms plot of the Short Pulse Radar Type
7. Measurement of the aggregate duration of the Channel Closed Transmission Time method. With the spectrum analyzer set to zero span tuned to the center frequency of the EUT operating channel at the radar simulated frequency, peak detection, and max hold, the dwell time per bin is given by:  $Dwell (0.3ms) = S (12000ms) / B (4000)$ ; where Dwell is the dwell time per spectrum analyzer sampling bin, S is sweep time and B is the number of spectrum analyzer sampling bins. An upper bound of the aggregate duration of the intermittent control signals of Channel Closing Transmission Time is calculated by:  $C (ms) = N \times Dwell (0.3ms)$ ; where C is the Closing Time, N is the number of spectrum analyzer sampling bins (intermittent control signals) showing a U-NII transmission and Dwell is the dwell time per bin.
8. Measurement the EUT for more than 30 minutes following the channel move time to verify that no transmission or beacons occur on this channel.

**TEST MODE:**

Please refer to the clause 2.2

**9.9 RESULT OF CHANNEL MOVE TIME, CHANNEL CLOSING TRANSMISSION TIME AND NON-OCCUPANCY PERIOD FOR CLIENT BEACON TEST**

Test data reference attachment.

## 10. ANTENNA REQUIREMENT

### 10.1 STANDARD REQUIREMENT

15.203 requirement: For intentional device, according to 15.203: an intentional radiator shall be designed to ensure that no antenna other than that furnished by the responsible party shall be used with the device.

### 10.2 EUT ANTENNA

The EUT antenna is permanent attached FPCB Antenna (antenna gain: 4.99 dBi). It comply with the standard requirement.

END OF REPORT