

Label Design

Model Name: PD15

FCC ID: 2ATV5-PD15

IC: 25229-PD15

PICANOL | Model: PD15 | Part nr.: BE322130.04

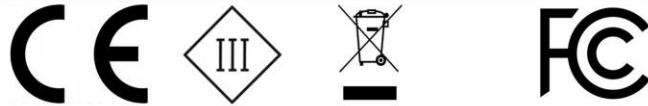

Serial nr.:



SELV  26V ± 10% Max. 1A

Contains FCC ID: XF6-RS9113SB

Contains IC: 8407A-RS9113SB

FCC ID: 2ATV5-PD15

IC: 25229-PD15

Picanol N.V. Steverlyncklaan 15 - 8900 Ieper - Belgium

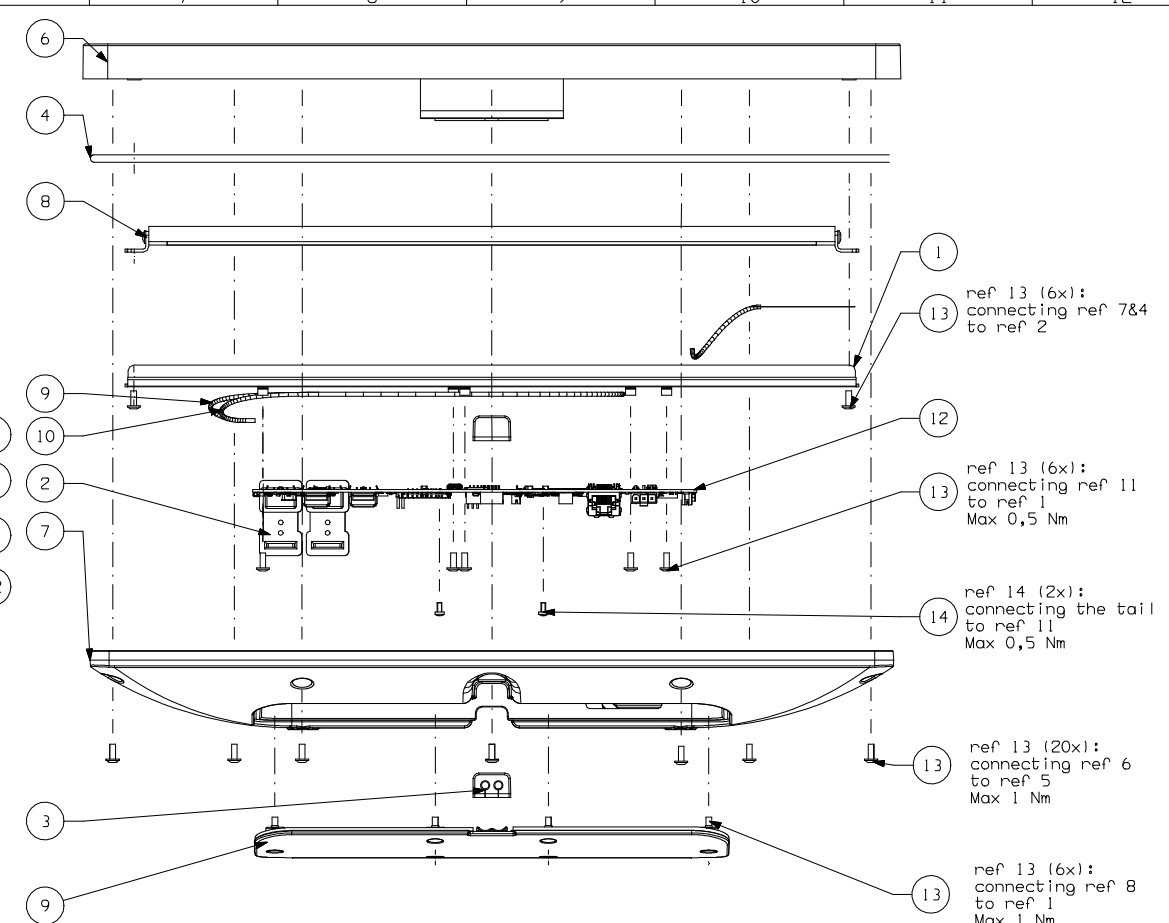
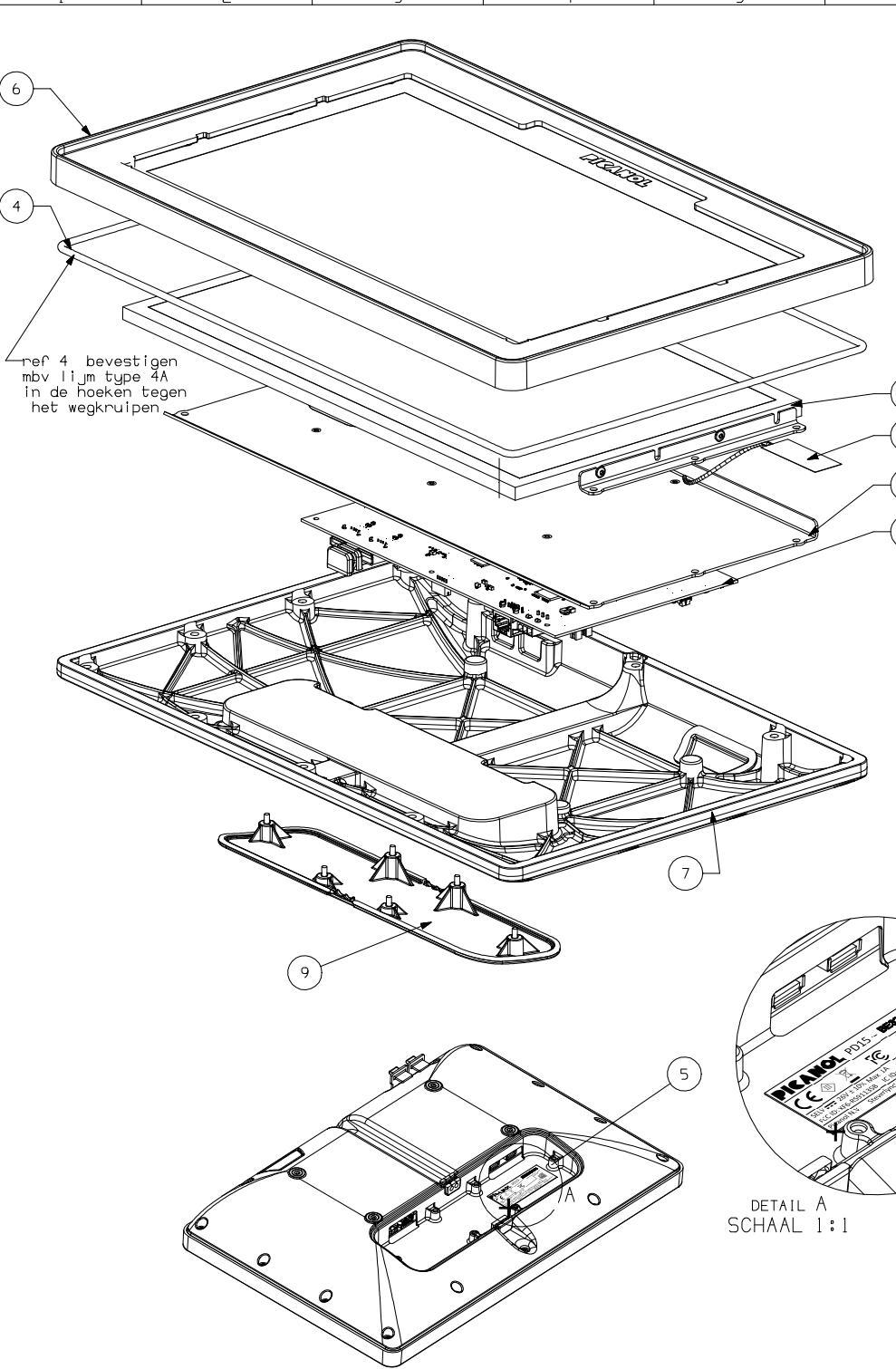

Assemble according to VS000967

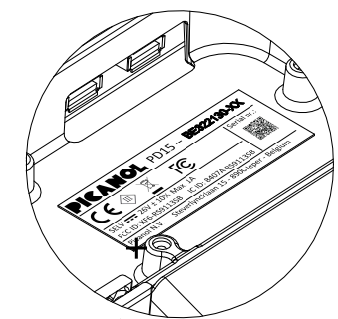

DETAIL A
SCHAAL 1:1

VT_2,5x5	2 pcs	VT	14		
NI300372	26 pcs	torx bolkopflensschroef M3x8	13	X5CrNi18-10	- 1.4301
BE801155	1 pcs	printplaat	12		
BE801112	2 pcs	TFT-LCD cable	11		
BE801111	1 pcs	Backlight cable 15inch 26cm	10		
BE323143	1 pcs	Af schermkapje	9		
BE322369	1 pcs	scherm	8		
BE322131	1 pcs	achterkap display	7		
BE322111	1 pcs	bezel met glasplaat	6		
BA323142	1 pcs	STICKER	5		
BA322121	1 pcs	schuimrubber snoer	4	CR (Polychloroprene Rubber)	
BA322014	1 pcs	kabelafdichtingsrubber	3	EPDM	
BA321839	2 pcs	afdichtrubber	2	non conducting EPDM 70 Shore	
BA321823	1 pcs	bevestigingsplaat	1	DX51D+Z275 - 1.0226	
PART NO.	Quant.	Unit	NAME	REF	NX MATERIAL
					REMARK

NX Tekening	BG/SG : /		
	Materiaal : EPDM		PMS :
	Behandeling :		
	Ontwerp svdl	Benaming : Display PD15	
	Wijziging rmmr	Nummer : BE.3221.30.04 NOT OFFICIAL	
Tolerantieklasse PND.01.00	PICANOL NV IEPER BELGIE	Deze tekening is uitsluitend eigendom van Picanol NV en mag noch geheel noch gedeeltelijk vernoemd of overgenomen worden aan derden zonder onze schriftelijke toestemming.	