

Reference level CH11

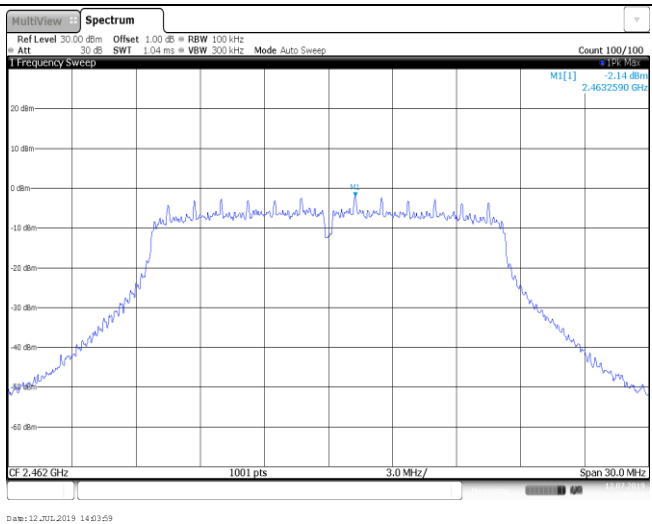

CH11

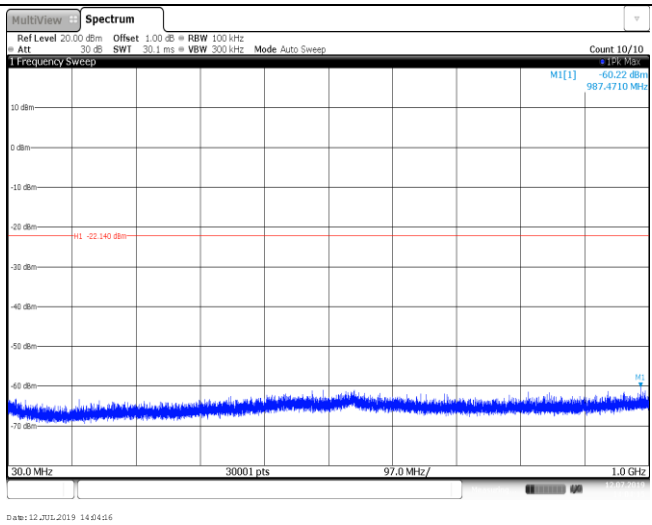

CH11

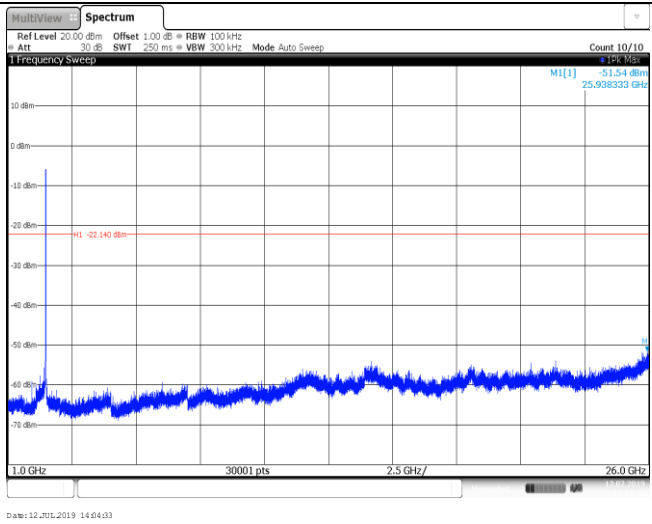

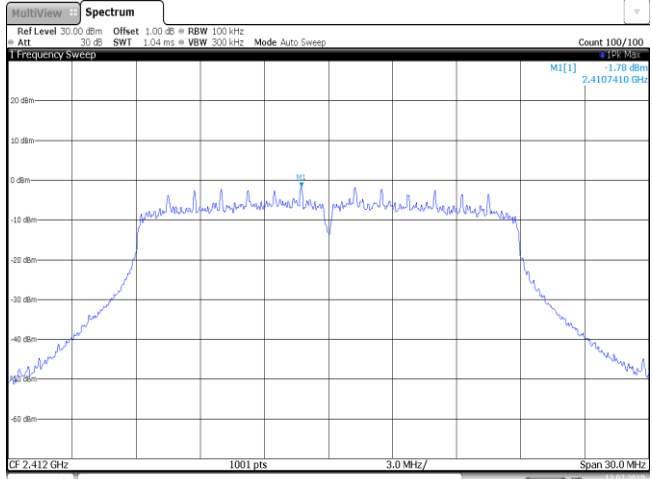
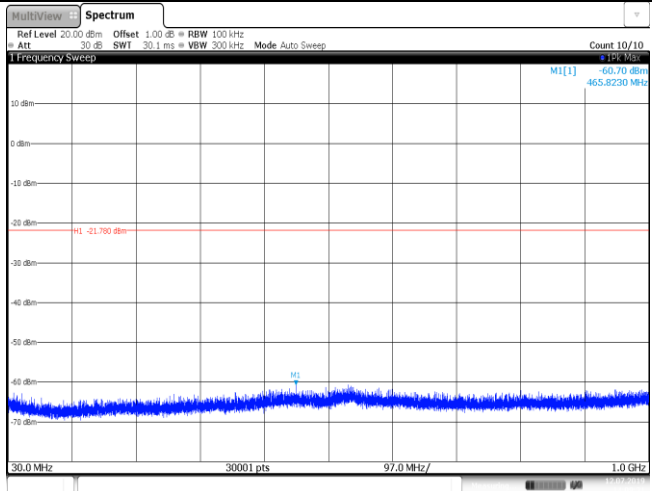
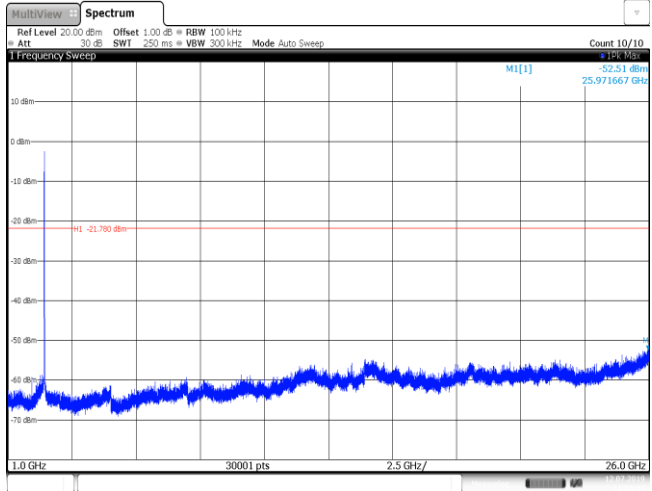
Test Item:	SE	802.11 n(HT20)	Antenna 1
Reference level CH01			
CH01			
			

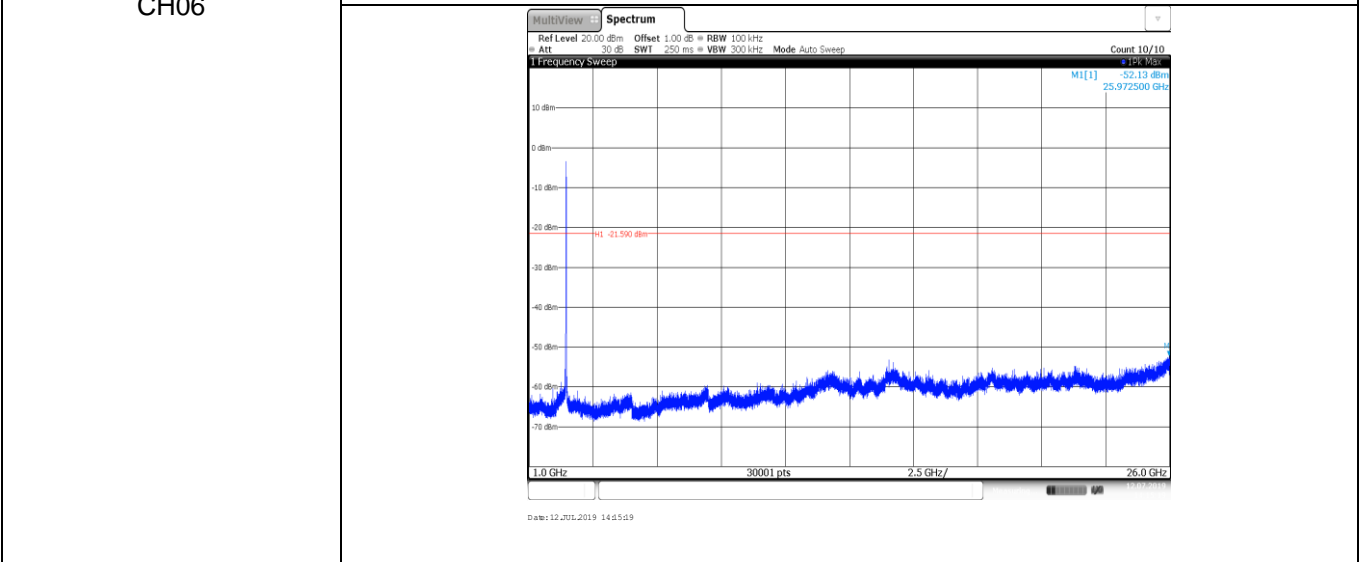
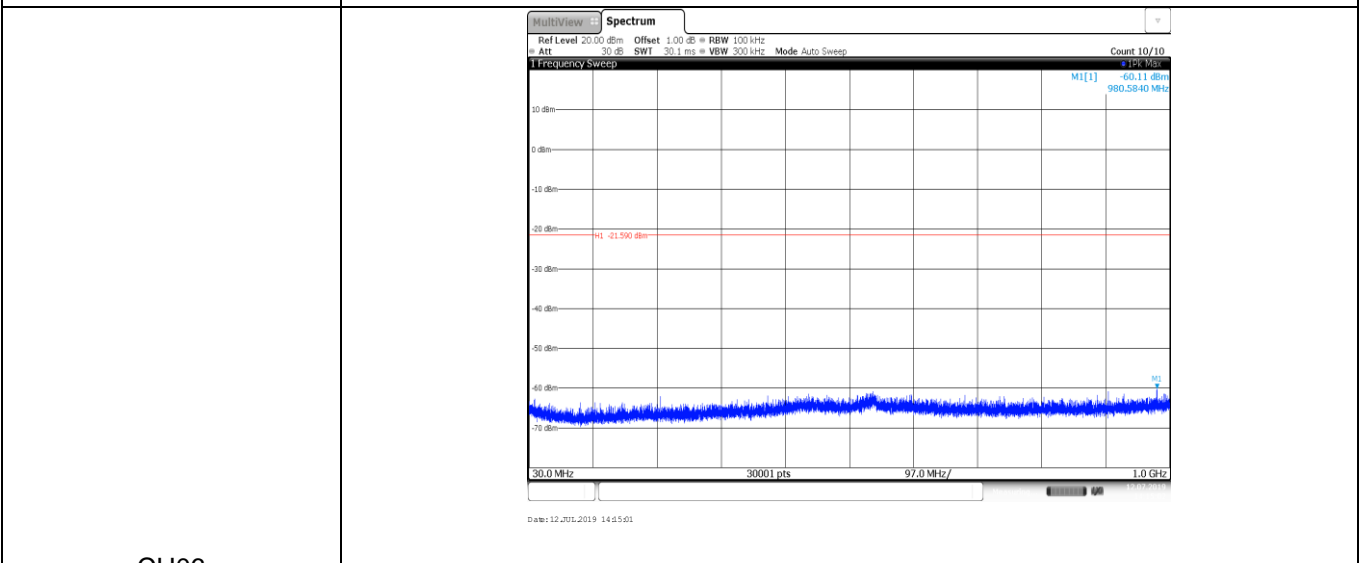
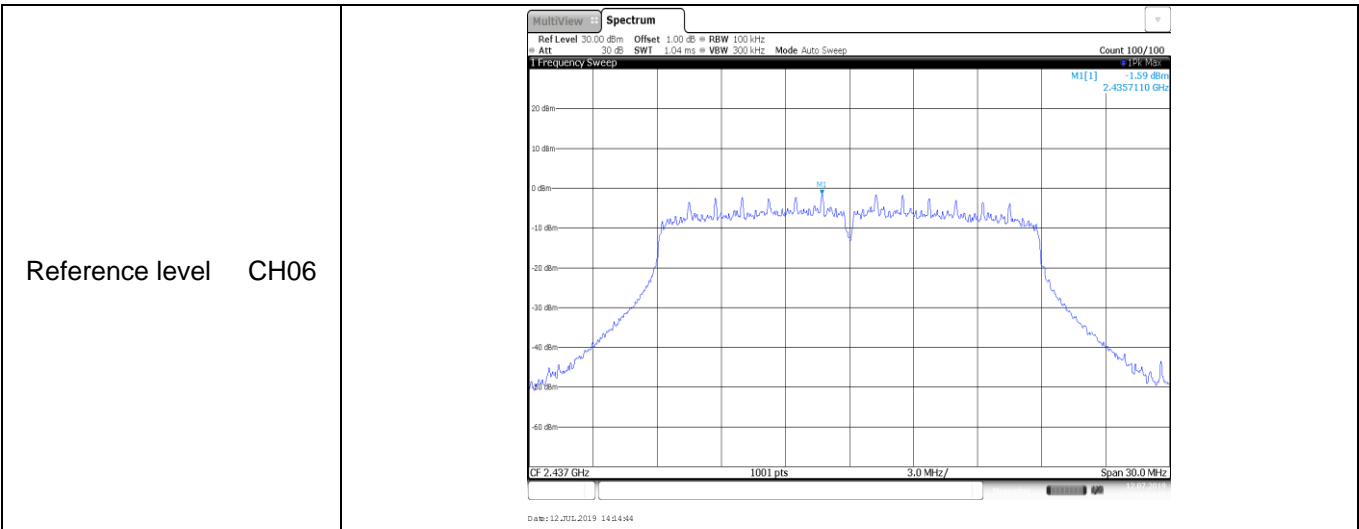

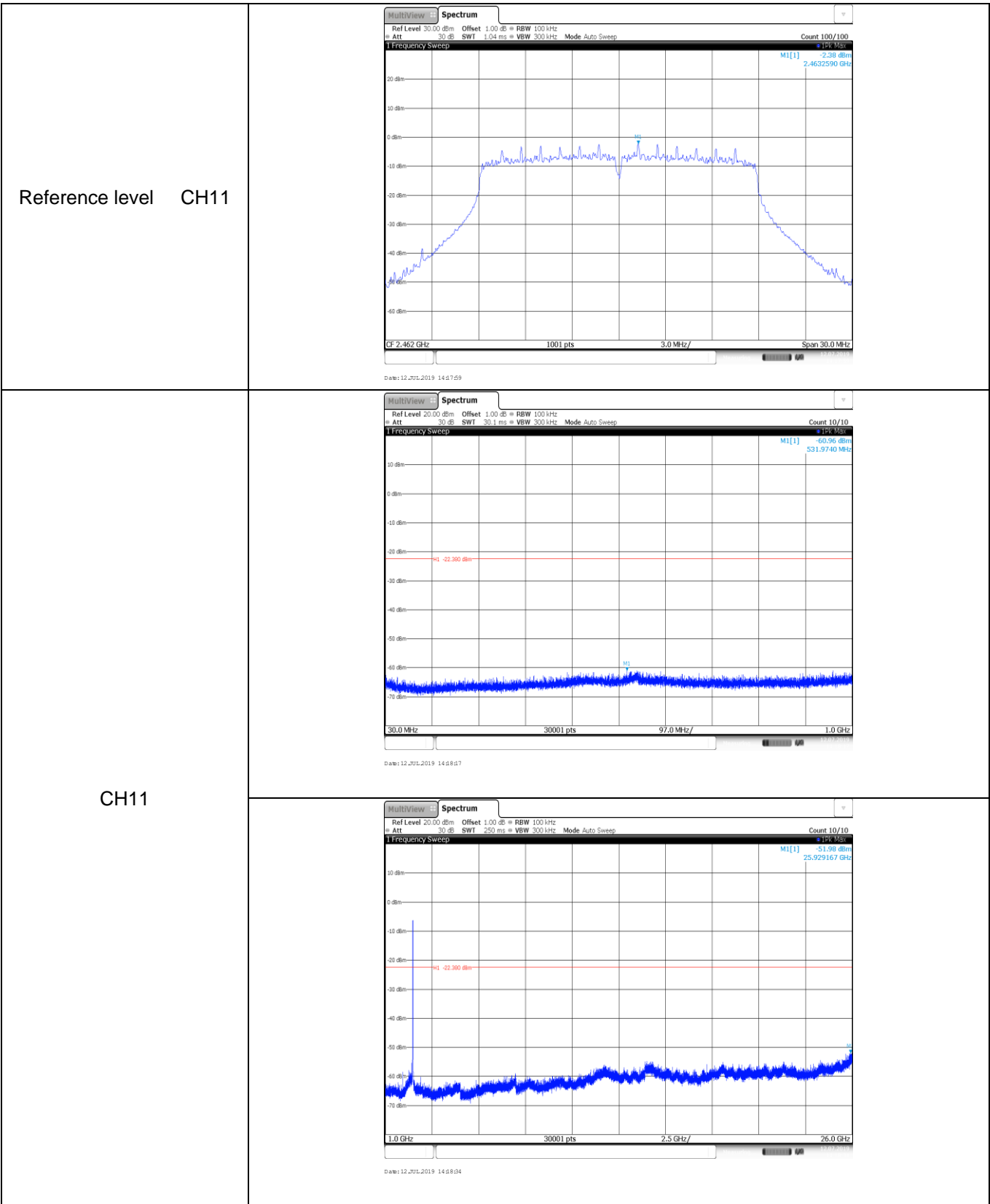

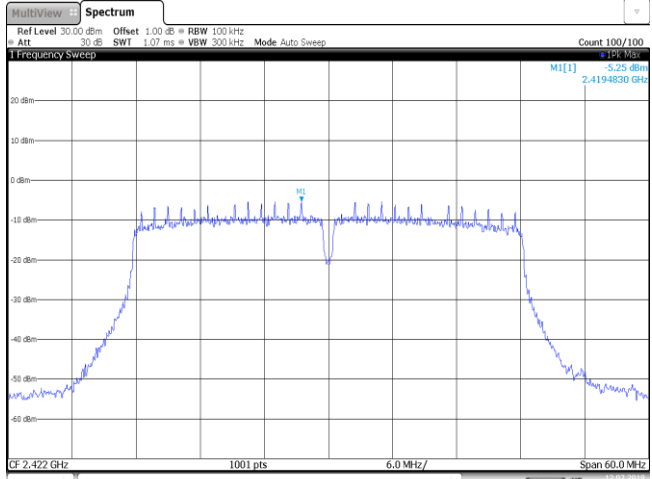
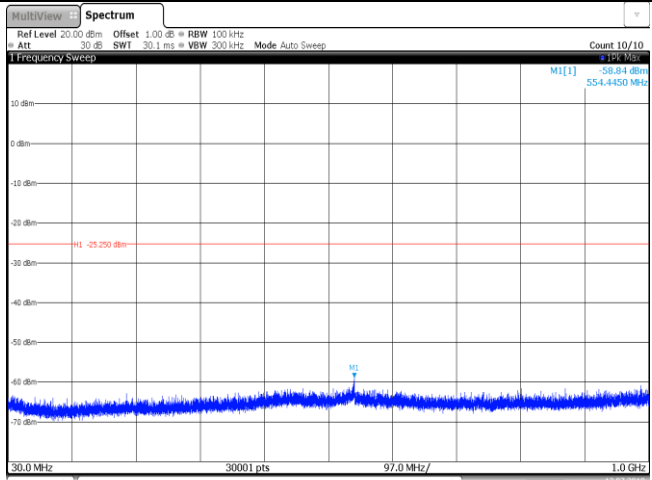
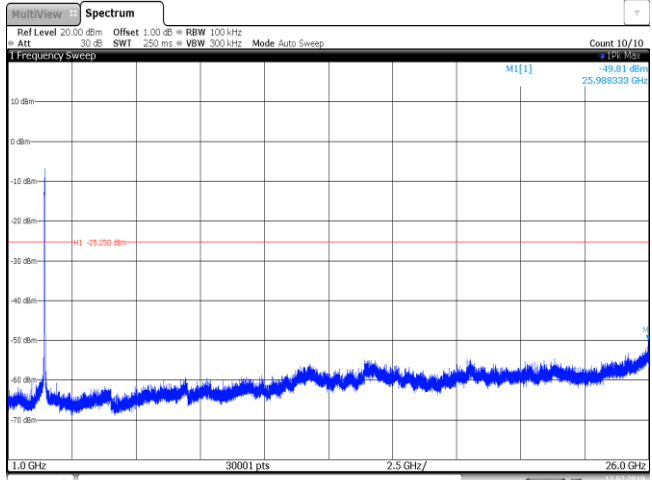
Test Item:	SE	802.11 n(HT40)	Antenna 1
Reference level CH03	 <p>Date: 12 JUL 2019 14:24:54</p>		
CH03	 <p>Date: 12 JUL 2019 14:25:11</p>		
	 <p>Date: 12 JUL 2019 14:25:29</p>		

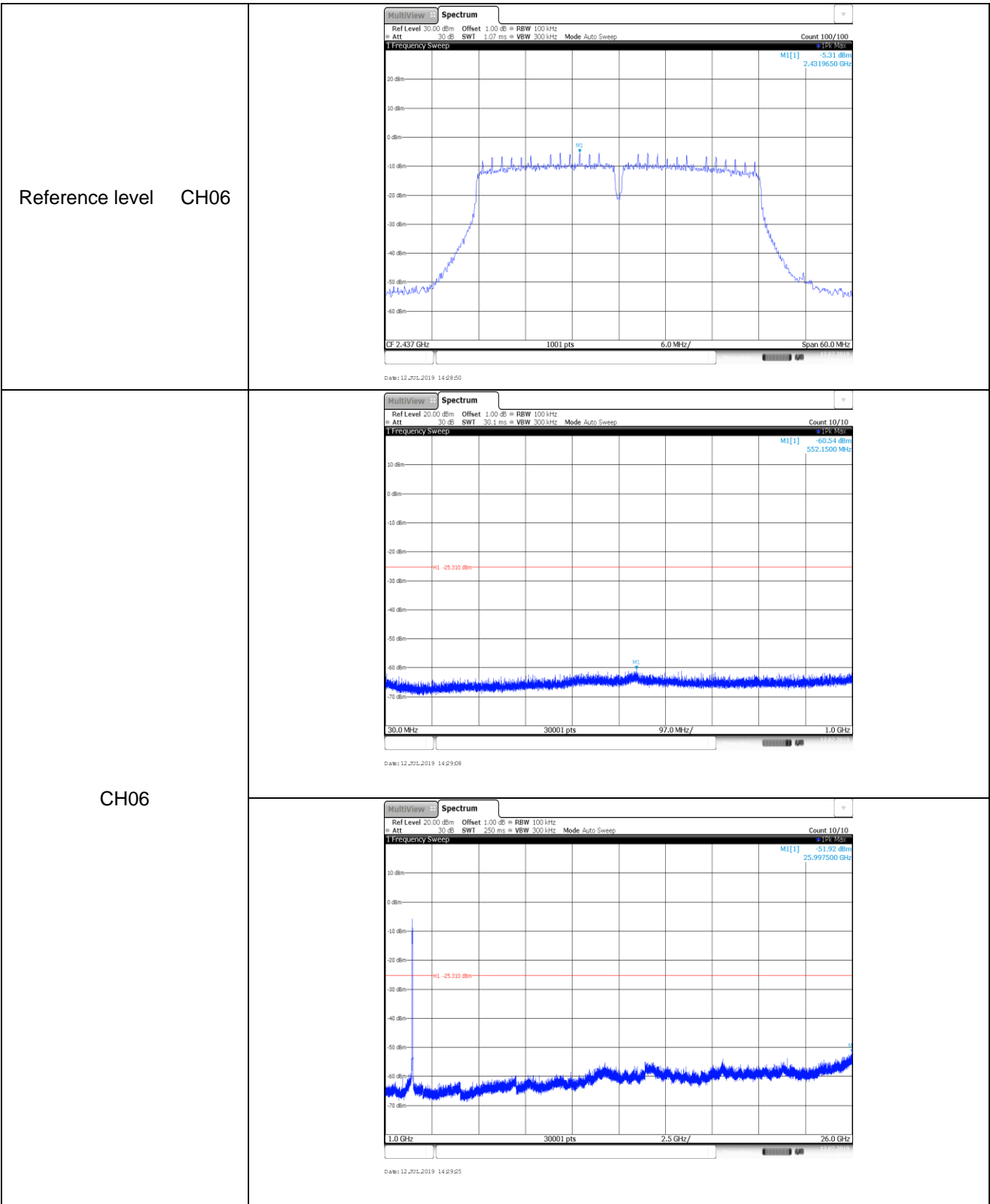

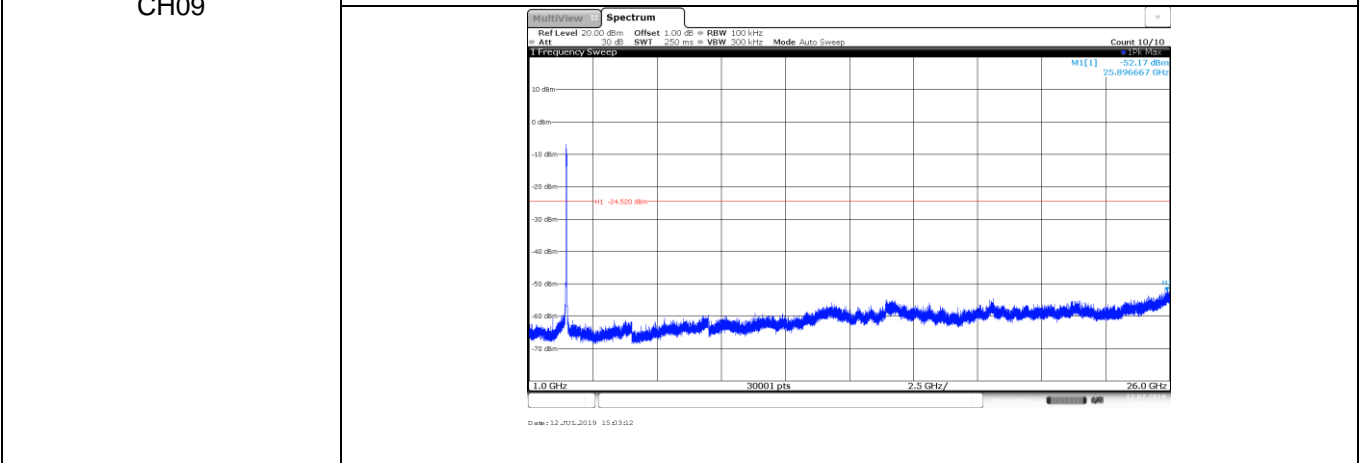
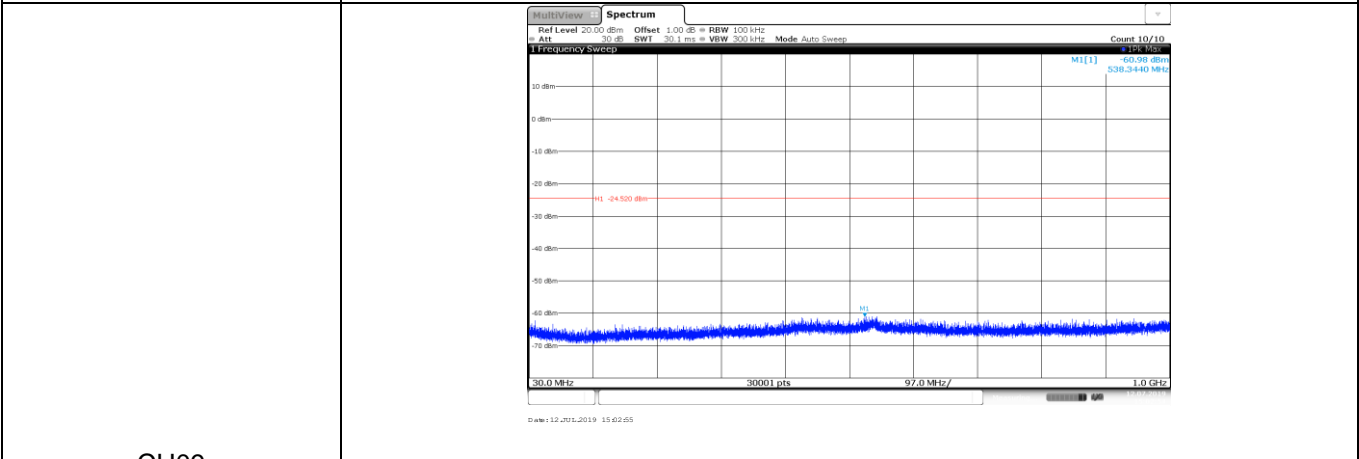
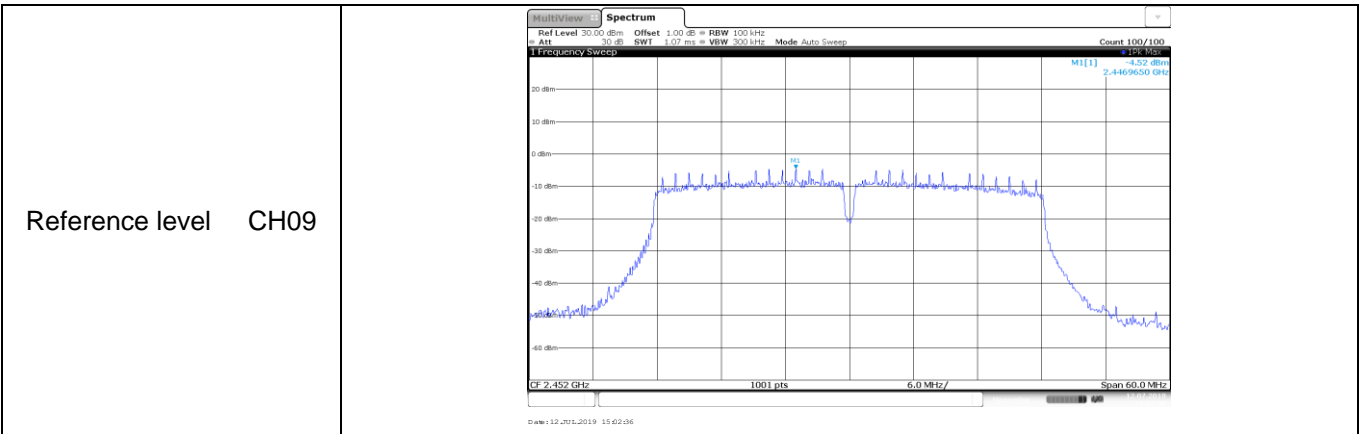

5.8. Spurious Emissions (Radiated)

LIMIT

FCC CFR Title 47 Part 15 Subpart C Section 15.209

Frequency	Limit (dBuV/m @3m)	Value
30MHz-88MHz	40.00	Quasi-peak
88MHz-216MHz	43.50	Quasi-peak
216MHz-960MHz	46.00	Quasi-peak
960MHz-1GHz	54.00	Quasi-peak
Above 1GHz	54.00	Average
	74.00	Peak

TEST CONFIGURATION

➤ 9kHz ~30MHz

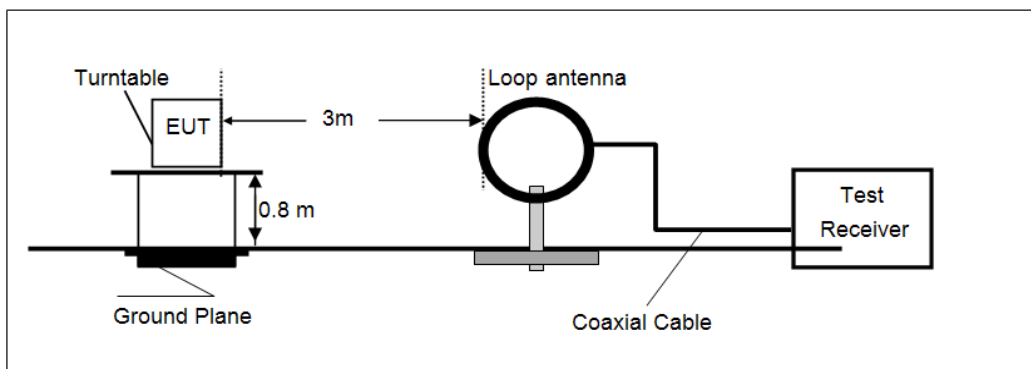

➤ 30MHz ~ 1GHz

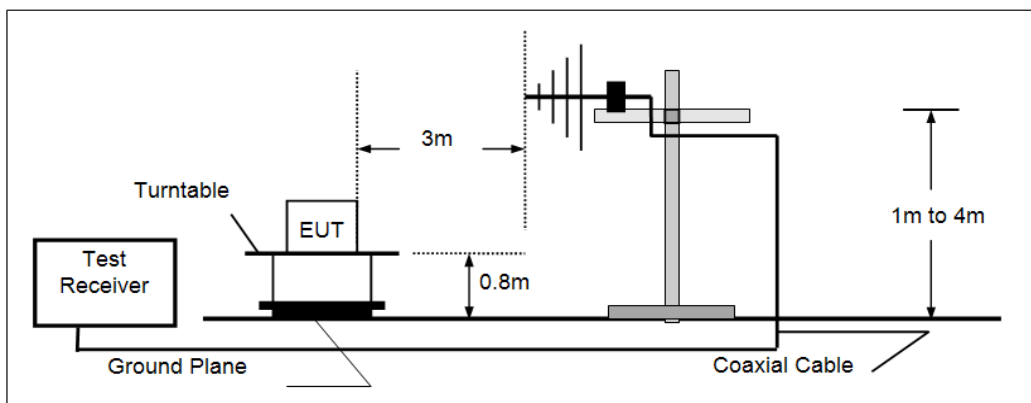

➤ Above 1GHz

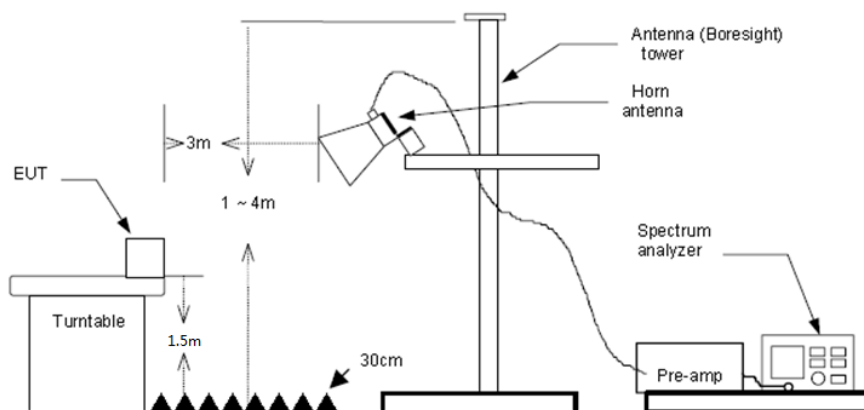

TEST PROCEDURE

1. The EUT was tested according to ANSI C63.10:2013 for compliance to FCC 47CFR 15.247 requirements.
2. The EUT is placed on a turn table which is 0.8 meter above ground. The turn table is rotated 360 degrees to determine the position of the maximum emission level.
3. The EUT was positioned such that the distance from antenna to the EUT was 3 meters.
4. The antenna is scanned from 1 meter to 4 meters to find out the maximum emission level. This is repeated for both horizontal and vertical polarization of the antenna.
5. Use the following spectrum analyzer settings
 - (1) Span shall wide enough to fully capture the emission being measured;
 - (2) Below 1GHz, RBW=120kHz, VBW=300kHz, Sweep=auto, Detector function=peak, Trace=max hold;
If the emission level of the EUT measured by the peak detector is 3 dB lower than the applicable limit, the peak emission level will be reported. Otherwise, the emission measurement will be repeated using the quasi-peak detector and reported.
 - (3) Above 1GHz, RBW=1MHz, VBW=3MHz PEAK detector for Peak value.
RBW=1MHz, VBW=3MHz RMS detector for Average value.

TEST MODE:

Please refer to the clause 3.3

TEST RESULTS

Passed **Not Applicable**

Note:

- 1) Final Level =Receiver Read level + Antenna Factor + Cable Loss – Preamplifier Factor
- 2) The emission levels of other frequencies are very lower than the limit and not show in test report.

➤ **9kHz ~ 30MHz**

The EUT was pre-scanned the frequency band (9kHz~30MHz), found the radiated level lower than the limit, so don't show on the report.

➤ **30MHz ~1000MHz**

Have pre-scan all modulation mode, found the 802.11b mode CH01 which it was worst case, so only the worst case's data on the test report.

➤ 30MHz ~ 1GHz

Polarization: Vertical

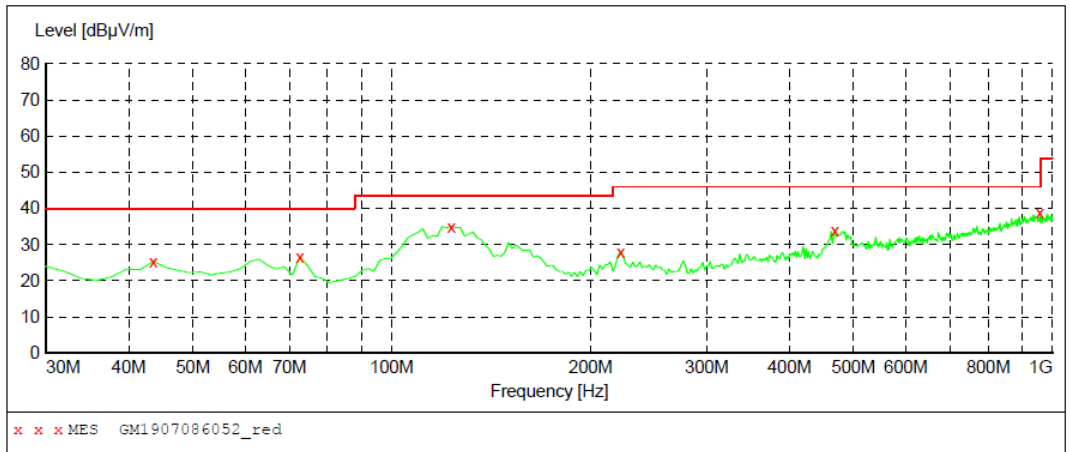

MEASUREMENT RESULT: "GM1907086052_red"

7/8/2019 6:02PM

Frequency MHz	Level dBµV/m	Transd dB	Limit dBµV/m	Margin dB	Det.	Height cm	Azimuth deg	Polarization
43.580000	25.40	-5.2	40.0	14.6	QP	100.0	316.00	VERTICAL
72.680000	26.60	-10.2	40.0	13.4	QP	100.0	224.00	VERTICAL
123.120000	35.00	-8.9	43.5	8.5	QP	100.0	264.00	VERTICAL
222.060000	28.00	-5.9	46.0	18.0	QP	100.0	345.00	VERTICAL
468.440000	33.80	0.8	46.0	12.2	QP	100.0	248.00	VERTICAL
957.320000	38.80	10.9	46.0	7.2	QP	100.0	33.00	VERTICAL

Polarization: Horizontal

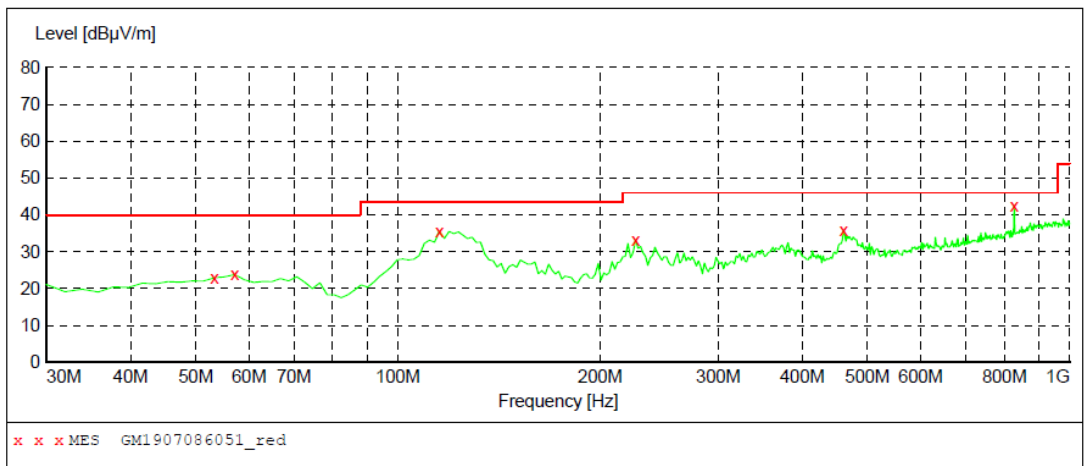

MEASUREMENT RESULT: "GM1907086051_red"

7/8/2019 6:00PM

Frequency MHz	Level dBµV/m	Transd dB	Limit dBµV/m	Margin dB	Det.	Height cm	Azimuth deg	Polarization
53.280000	22.90	-5.1	40.0	17.1	QP	100.0	74.00	HORIZONTAL
57.160000	23.80	-5.5	40.0	16.2	QP	300.0	257.00	HORIZONTAL
115.360000	35.60	-7.7	43.5	7.9	QP	300.0	137.00	HORIZONTAL
225.940000	33.30	-5.7	46.0	12.7	QP	100.0	245.00	HORIZONTAL
460.680000	35.70	0.7	46.0	10.3	QP	100.0	193.00	HORIZONTAL
827.340000	42.60	8.6	46.0	3.4	QP	100.0	34.00	HORIZONTAL

➤ Above 1 GHz

802.11b				CH01			
Freq. [MHz]	Reading [dB μ V/m]	Factor [dB]	Level [dB μ V/m]	Limit [dB μ V/m]	Margin [dB]	Polarity	Detector
3197.2500	35.37	0.83	36.20	74.00	37.80	Vertical	PK
4128.4375	37.24	3.41	40.65	74.00	33.35	Vertical	PK
4978.8438	37.53	7.71	45.24	74.00	28.76	Vertical	PK
7236.3125	33.50	16.01	49.51	74.00	24.49	Vertical	PK
2991.6250	40.83	-0.07	40.76	74.00	33.24	Horizontal	PK
4128.4375	37.32	3.41	40.73	74.00	33.27	Horizontal	PK
4995.0000	32.36	7.82	40.18	74.00	33.82	Horizontal	PK
5845.4063	30.66	9.75	40.41	74.00	33.59	Horizontal	PK

802.11b				CH06			
Freq. [MHz]	Reading [dB μ V/m]	Factor [dB]	Level [dB μ V/m]	Limit [dB μ V/m]	Margin [dB]	Polarity	Detector
2993.0938	46.52	-0.08	46.44	74.00	27.56	Horizontal	PK
4128.4375	37.46	3.41	40.87	74.00	33.13	Horizontal	PK
5235.8750	31.70	8.79	40.49	74.00	33.51	Horizontal	PK
7154.0625	31.23	15.73	46.96	74.00	27.04	Horizontal	PK
3007.7813	35.70	-0.09	35.61	74.00	38.39	Vertical	PK
4126.9688	36.73	3.40	40.13	74.00	33.87	Vertical	PK
4978.8438	41.12	7.71	48.83	74.00	25.17	Vertical	PK
7312.6875	33.35	16.09	49.44	74.00	24.56	Vertical	PK

802.11b				CH11			
Freq. [MHz]	Reading [dB μ V/m]	Factor [dB]	Level [dB μ V/m]	Limit [dB μ V/m]	Margin [dB]	Polarity	Detector
2994.5625	46.56	-0.09	46.47	74.00	27.53	Vertical	PK
4128.4375	37.23	3.41	40.64	74.00	33.36	Vertical	PK
4997.9375	41.70	7.84	49.54	74.00	24.46	Vertical	PK
7392.0000	31.83	16.34	48.17	74.00	25.83	Vertical	PK
2987.2188	45.87	-0.05	45.82	74.00	28.18	Horizontal	PK
4128.4375	38.15	3.41	41.56	74.00	32.44	Horizontal	PK
5682.3750	31.92	8.82	40.74	74.00	33.26	Horizontal	PK
7387.5938	31.01	16.33	47.34	74.00	26.66	Horizontal	PK

Remark:

1. Final Level = Receiver Read level + Antenna Factor + Cable Loss – Preamplifier Factor
2. The peak level is lower than average limit(54 dBuV/m), this data is the too weak instrument of signal is unable to test.
3. The emission levels of other frequencies are very lower than the limit and not show in test report.

802.11g					CH01		
Freq. [MHz]	Reading [dB μ V/m]	Factor [dB]	Level [dB μ V/m]	Limit [dB μ V/m]	Margin [dB]	Polarity	Detector
2988.6875	39.34	-0.05	39.29	74.00	34.71	Vertical	PK
3994.7813	39.70	3.00	42.70	74.00	31.30	Vertical	PK
4990.5938	40.98	7.79	48.77	74.00	25.23	Vertical	PK
7228.9688	35.23	16.01	51.24	74.00	22.76	Vertical	PK
2996.0313	40.86	-0.10	40.76	74.00	33.24	Horizontal	PK
4129.9063	37.24	3.42	40.66	74.00	33.34	Horizontal	PK
5795.4688	31.06	9.52	40.58	74.00	33.42	Horizontal	PK
7497.7500	31.74	16.41	48.15	74.00	25.85	Horizontal	PK

802.11g					CH06		
Freq. [MHz]	Reading [dB μ V/m]	Factor [dB]	Level [dB μ V/m]	Limit [dB μ V/m]	Margin [dB]	Polarity	Detector
2997.5000	42.17	-0.11	42.06	74.00	31.94	Horizontal	PK
4128.4375	38.05	3.41	41.46	74.00	32.54	Horizontal	PK
5795.4688	31.43	9.52	40.95	74.00	33.05	Horizontal	PK
7972.1563	31.23	17.94	49.17	74.00	24.83	Horizontal	PK
2985.7500	44.29	-0.04	44.25	74.00	29.75	Vertical	PK
4128.4375	37.29	3.41	40.70	74.00	33.30	Vertical	PK
4986.1875	35.98	7.76	43.74	74.00	30.26	Vertical	PK
7309.7500	34.46	16.08	50.54	74.00	23.46	Vertical	PK

802.11g					CH11		
Freq. [MHz]	Reading [dB μ V/m]	Factor [dB]	Level [dB μ V/m]	Limit [dB μ V/m]	Margin [dB]	Polarity	Detector
2988.6875	43.93	-0.05	43.88	74.00	30.12	Vertical	PK
4248.8750	42.87	3.80	46.67	74.00	27.33	Vertical	PK
4984.7188	41.29	7.75	49.04	74.00	24.96	Vertical	PK
7176.0938	30.74	15.86	46.60	74.00	27.40	Vertical	PK
2997.5000	43.05	-0.11	42.94	74.00	31.06	Horizontal	PK
4128.4375	38.07	3.41	41.48	74.00	32.52	Horizontal	PK
5197.6875	32.13	8.98	41.11	74.00	32.89	Horizontal	PK
7146.7188	31.48	15.69	47.17	74.00	26.83	Horizontal	PK

Remark:

1. Final Level = Receiver Read level + Antenna Factor + Cable Loss – Preamplifier Factor
2. The peak level is lower than average limit(54 dB μ V/m), this data is the too weak instrument of signal is unable to test.
3. The emission levels of other frequencies are very lower than the limit and not show in test report.

802.11n(HT20)					CH01		
Freq. [MHz]	Reading [dB μ V/m]	Factor [dB]	Level [dB μ V/m]	Limit [dB μ V/m]	Margin [dB]	Polarity	Detector
3191.3750	34.70	0.80	35.50	74.00	38.50	Vertical	PK
4126.9688	36.90	3.40	40.30	74.00	33.70	Vertical	PK
4996.4688	35.17	7.83	43.00	74.00	31.00	Vertical	PK
8072.0313	31.58	18.30	49.88	74.00	24.12	Vertical	PK
1521.4063	34.71	-5.77	28.94	74.00	45.06	Horizontal	PK
3201.6563	34.33	0.82	35.15	74.00	38.85	Horizontal	PK
4128.4375	38.33	3.41	41.74	74.00	32.26	Horizontal	PK
5159.5000	32.81	8.91	41.72	74.00	32.28	Horizontal	PK

802.11n(HT20)					CH06		
Freq. [MHz]	Reading [dB μ V/m]	Factor [dB]	Level [dB μ V/m]	Limit [dB μ V/m]	Margin [dB]	Polarity	Detector
1232.0625	34.47	-5.75	28.72	74.00	45.28	Horizontal	PK
3507.1563	33.03	1.08	34.11	74.00	39.89	Horizontal	PK
4128.4375	36.12	3.41	39.53	74.00	34.47	Horizontal	PK
5614.8125	31.36	8.84	40.20	74.00	33.80	Horizontal	PK
1569.8750	34.22	-6.08	28.14	74.00	45.86	Vertical	PK
3993.3125	37.70	3.00	40.70	74.00	33.30	Vertical	PK
4995.0000	36.78	7.82	44.60	74.00	29.40	Vertical	PK
6622.3750	30.71	13.22	43.93	74.00	30.07	Vertical	PK

802.11n(HT20)					CH11		
Freq. [MHz]	Reading [dB μ V/m]	Factor [dB]	Level [dB μ V/m]	Limit [dB μ V/m]	Margin [dB]	Polarity	Detector
2094.2188	32.96	-4.05	28.91	74.00	45.09	Vertical	PK
4254.7500	36.80	3.79	40.59	74.00	33.41	Vertical	PK
4986.1875	35.22	7.76	42.98	74.00	31.02	Vertical	PK
6124.4688	30.65	10.76	41.41	74.00	32.59	Vertical	PK
1663.8750	34.38	-6.17	28.21	74.00	45.79	Horizontal	PK
2988.6875	37.66	-0.05	37.61	74.00	36.39	Horizontal	PK
4129.9063	36.18	3.42	39.60	74.00	34.40	Horizontal	PK
5240.2813	31.39	8.77	40.16	74.00	33.84	Horizontal	PK

Remark:

1. Final Level = Receiver Read level + Antenna Factor + Cable Loss – Preamplifier Factor
2. The peak level is lower than average limit(54 dBuV/m), this data is the too weak instrument of signal is unable to test.
3. The emission levels of other frequencies are very lower than the limit and not show in test report.

802.11n(HT40)					CH03		
Freq. [MHz]	Reading [dB μ V/m]	Factor [dB]	Level [dB μ V/m]	Limit [dB μ V/m]	Margin [dB]	Polarity	Detector
1276.1250	35.32	-5.63	29.69	74.00	44.31	Horizontal	PK
3557.0938	33.07	1.28	34.35	74.00	39.65	Horizontal	PK
4128.4375	37.08	3.41	40.49	74.00	33.51	Horizontal	PK
6008.4375	31.21	10.48	41.69	74.00	32.31	Horizontal	PK
1258.5000	34.99	-5.68	29.31	74.00	44.69	Vertical	PK
3044.5000	35.10	0.08	35.18	74.00	38.82	Vertical	PK
4128.4375	36.40	3.41	39.81	74.00	34.19	Vertical	PK
8655.1250	31.93	19.02	50.95	74.00	23.05	Vertical	PK

802.11n(HT40)					CH06		
Freq. [MHz]	Reading [dB μ V/m]	Factor [dB]	Level [dB μ V/m]	Limit [dB μ V/m]	Margin [dB]	Polarity	Detector
1239.4063	35.04	-5.73	29.31	74.00	44.69	Vertical	PK
4128.4375	35.86	3.41	39.27	74.00	34.73	Vertical	PK
6150.9063	31.47	10.80	42.27	74.00	31.73	Vertical	PK
7042.4375	30.75	15.28	46.03	74.00	27.97	Vertical	PK
1412.7188	33.86	-5.59	28.27	74.00	45.73	Horizontal	PK
3194.3125	33.21	0.81	34.02	74.00	39.98	Horizontal	PK
6347.7188	31.17	11.13	42.30	74.00	31.70	Horizontal	PK
8583.1563	31.87	18.74	50.61	74.00	23.39	Horizontal	PK

802.11n(HT40)					CH09		
Freq. [MHz]	Reading [dB μ V/m]	Factor [dB]	Level [dB μ V/m]	Limit [dB μ V/m]	Margin [dB]	Polarity	Detector
2994.5625	37.08	-0.09	36.99	74.00	37.01	Horizontal	PK
4128.4375	36.54	3.41	39.95	74.00	34.05	Horizontal	PK
4774.6875	33.14	6.88	40.02	74.00	33.98	Horizontal	PK
5394.5000	31.32	8.61	39.93	74.00	34.07	Horizontal	PK
1671.2188	35.13	-6.15	28.98	74.00	45.02	Vertical	PK
3182.5625	34.25	0.75	35.00	74.00	39.00	Vertical	PK
4128.4375	35.50	3.41	38.91	74.00	35.09	Vertical	PK
6194.9688	31.36	10.87	42.23	74.00	31.77	Vertical	PK

Remark:

1. Final Level = Receiver Read level + Antenna Factor + Cable Loss – Preamplifier Factor
2. The peak level is lower than average limit(54 dBuV/m), this data is the too weak instrument of signal is unable to test.
3. The emission levels of other frequencies are very lower than the limit and not show in test report.