



TEST REPORT

Report No..... : **CHTEW19070055** Report verification : 

Project No..... : **SHT1906073903EW**

FCC ID..... : **2ATV2-WMBR-1**

Applicant's name..... : **Walmart, Inc. on behalf of its affiliate Project Franklin, LLC**

Address..... : 74 Kent St #2, Brooklyn, NY 11222

Manufacturer..... : Shenzhen ChampOn Technology Co. Ltd

Address..... : 628 Yi Ben BLDG, No.1063 Cha Guang rd, Xili, Nanshan, Shenzhen

Test item description : **Walmart WiFi Bridge**

Trade Mark : Walmart

Model/Type reference..... : WMBR-1

Listed Model(s) : -

Standard : **FCC CFR Title 47 Part 15 Subpart C Section 15.249**

Date of receipt of test sample..... : Jul.05, 2019

Date of testing..... : Jul.05, 2019- Jul.15, 2019

Date of issue..... : Jul.16, 2019

Result..... : **PASS**

Compiled by
(position+printedname+signature)....: File administrators Echo Wei

Supervised by
(position+printedname+signature)....: Project Engineer Edward Pan

Approved by
(position+printedname+signature)....: RF Manager Hans Hu

Testing Laboratory Name : **Shenzhen Huatongwei International Inspection Co., Ltd.**

Address..... : 1/F, Bldg 3, Hongfa Hi-tech Industrial Park, Genyu Road, Tianliao, Gongming, Shenzhen, China

Shenzhen Huatongwei International Inspection Co., Ltd. All rights reserved.

This publication may be reproduced in whole or in part for non-commercial purposes as long as the Shenzhen Huatongwei International Inspection Co., Ltd. is acknowledged as copyright owner and source of the material. Shenzhen Huatongwei International Inspection Co., Ltd. takes no responsibility for and will not assume liability for damages resulting from the reader's interpretation of the reproduced material due to its placement and context.

The test report merely correspond to the test sample.

Contents

1.	<u>TEST STANDARDS AND REPORT VERSION</u>	3
1.1.	Test Standards	3
1.2.	Report version information	3
2.	<u>TEST DESCRIPTION</u>	4
3.	<u>SUMMARY</u>	5
3.1.	Client Information	5
3.2.	Product Description	5
3.3.	EUT operation mode	5
3.4.	EUT configuration	6
3.5.	Modifications	6
4.	<u>TEST ENVIRONMENT</u>	7
4.1.	Address of the test laboratory	7
4.2.	Test Facility	7
4.3.	Environmental conditions	8
4.4.	Statement of the measurement uncertainty	8
4.5.	Equipments Used during the Test	9
5.	<u>TEST CONDITIONS AND RESULTS</u>	11
5.1.	Antenna requirement	11
5.2.	AC Power Conducted Emissions	12
5.3.	20 dB Bandwidth	15
5.4.	Radiated field strength of the fundamental signal	17
5.5.	Radiated Spurious Emissions and Bandedge Emission	19
6.	<u>TEST SETUP PHOTOS OF THE EUT</u>	24
7.	<u>EXTERNAL AND INTERNAL PHOTOS OF THE EUT</u>	25

1. TEST STANDARDS AND REPORT VERSION

1.1. Test Standards

The tests were performed according to following standards:

[FCC Rules Part 15.249](#): Operation within the bands 902-928 MHz, 2400-2483.5 MHz, 5725-5875 MHz, and 24.0-24.25 GHz.

[ANSI C63.10-2013](#): American National Standard for Testing Unlicensed Wireless Devices.

1.2. Report version information

Revision No.	Date of issue	Description
N/A	2019-07-16	Original

2. TEST DESCRIPTION

Test Item	Section in CFR 47	Result	Test Engineer
Antenna requirement	15.203	PASS	JiongSheng.Feng
AC Power Line Conducted Emissions	15.207	PASS	Zhiwei Liu
20dB Bandwidth	15.215/15.249	PASS	JiongSheng.Feng
Field strength of the Fundamental signal	15.249(a)	PASS	Xu Yang
Spurious Emissions	15.209/15.249(a)	PASS	Xu Yang
Band edge Emissions	15.205/15.249(d)	PASS	Xu Yang

Remark: The measurement uncertainty is not included in the test result.

3. SUMMARY

3.1. Client Information

Applicant:	Walmart, Inc. on behalf of its affiliate Project Franklin, LLC
Address:	74 Kent St #2, Brooklyn, NY 11222
Manufacturer:	Shenzhen ChampOn Technology Co. Ltd
Address:	628 Yi Ben BLDG, No.1063 Cha Guang rd, Xili, Nanshan, Shenzhen

3.2. Product Description

Name of EUT:	Walmart WiFi Bridge
Trade Mark:	Walmart
Model No.:	WMBR-1
Listed Model(s):	-
Power supply:	DC 5V
RF Specification	
Operation frequency:	908.40MHz and 916.00MHz
Channel number:	2
Modulation Type:	FSK
Antenna type:	Integral antenna
Antenna gain:	3dBi

3.3. EUT operation mode

- **Test frequency list**

According to section 15.31(m), regards to the operating frequency range over 10 MHz, must select three channel which were tested. the Lowest frequency, the middle frequency, and the highest frequency of channel were selected to perform the test, please see the above gray bottom.

Channel	Frequency (MHz)
CH _L	908.40
CH _H	916.00

- **TEST MODE**

For RF test items
The engineering test program was provided and enabled to make EUT continuous transmit.
For AC power line conducted emissions:
The EUT was set to connect with large package sizes transmission.

3.4. EUT configuration

The following peripheral devices and interface cables were connected during the measurement:

- - supplied by the manufacturer
- - supplied by the lab

		Manufacturer :	/
		Model No. :	/
○	Notebook	Manufacturer:	TOSHIBA
		Model No.:	Satellite M800

3.5. Modifications

No modifications were implemented to meet testing criteria.

4. TEST ENVIRONMENT

4.1. Address of the test laboratory

Laboratory: Shenzhen Huatongwei International Inspection Co., Ltd.

Address: 1/F, Bldg 3, Hongfa Hi-tech Industrial Park, Genyu Road, Tianliao, Gongming, Shenzhen, China

Phone: 86-755-26748019 Fax: 86-755-26748089

4.2. Test Facility

The test facility is recognized, certified, or accredited by the following organizations:

CNAS-Lab Code: L1225

Shenzhen Huatongwei International Inspection Co., Ltd. has been assessed and proved to be in compliance with CNAS-CL01 Accreditation Criteria for Testing and Calibration Laboratories (identical to ISO/IEC17025: 2005 General Requirements) for the Competence of Testing and Calibration Laboratories.

A2LA-Lab Cert. No. 3902.01

Shenzhen Huatongwei International Inspection Co., Ltd. EMC Laboratory has been accredited by A2LA for technical competence in the field of electrical testing, and proved to be in compliance with ISO/IEC 17025: 2005 General Requirements for the Competence of Testing and Calibration Laboratories and any additional program requirements in the identified field of testing.

FCC-Registration No.: 762235

Shenzhen Huatongwei International Inspection Co., Ltd. EMC Laboratory has been registered and fully described in a report filed with the FCC (Federal Communications Commission). The acceptance letter from the FCC is maintained in our files. Registration 762235.

IC-Registration No.: 5377A

Two 3m Alternate Test Site of Shenzhen Huatongwei International Inspection Co., Ltd. has been registered by Certification and Engineering Bureau of Industry Canada for the performance of radiated measurements with Registration No. 5377A.

ACA

Shenzhen Huatongwei International Inspection Co., Ltd. EMC Laboratory can also perform testing for the Australian C-Tick mark as a result of our A2LA accreditation.

4.3. Environmental conditions

During the measurement the environmental conditions were within the listed ranges:

Temperature:	15~35°C
Relative Humidity:	30~60 %
Air Pressure:	950~1050mba

4.4. Statement of the measurement uncertainty

The data and results referenced in this document are true and accurate. The reader is cautioned that there may be errors in calibration limits of the equipment and facilities. The measurement uncertainty was calculated for all measurements listed in this test report according to TR-100028-01 "Electromagnetic compatibility and Radio spectrum Matters (ERM);Uncertainties in the measurement of mobile radio equipment characteristics;Part 1" and TR-100028-02 "Electromagnetic compatibility and Radio spectrum Matters (ERM);Uncertainties in the measurementof mobile radio equipment characteristics;Part 2" and is documented in the Shenzhen Huatongwei International Inspection Co., Ltd quality system according to ISO/IEC 17025. Further more, component and process variability of devices similar to that tested may result in additional deviation. The manufacturer has the sole responsibility of continued compliance of the device.

Here after the best measurement capability for Shenzhen Huatongwei is reported:

Test Items	Measurement Uncertainty	Notes
Conducted spurious emissions 9kHz~40GHz	0.51 dB	(1)
Conducted Disturbance 150kHz~30MHz	3.02 dB	(1)
Radiated Emissions below 1GHz	4.90 dB	(1)
Radiated Emissions above 1GHz	4.96 dB	(1)
Occupied Bandwidth	15 Hz	(1)

(1) This uncertainty represents an expanded uncertainty expressed at approximately the 95% confidence level using a coverage factor of k=1.96.

4.5. Equipments Used during the Test

● Conducted Emission						
Used	Test Equipment	Manufacturer	Model No.	Serial No.	Last Cal. Date (YY-MM-DD)	Next Cal. Date (YY-MM-DD)
●	Shielded Room	Albatross projects	N/A	N/A	2018/09/28	2023/09/27
●	EMI Test Receiver	R&S	ESCI	101247	2018/10/27	2019/10/26
●	Artificial Mains	SCHWARZBECK	NNLK 8121	573	2018/10/27	2019/10/26
●	Pulse Limiter	R&S	ESH3-Z2	100499	2018/10/27	2019/10/26
●	RF Connection Cable	HUBER+SUHNER	EF400	N/A	2018/11/15	2019/11/14
●	Test Software	R&S	ES-K1	N/A	N/A	N/A
○	Single Balanced Telecom Pair ISN	FCC	FCC-TLISN-T2-02	20371	2018/10/28	2019/10/27
○	Two Balanced Telecom Pairs ISN	FCC	FCC-TLISN-T4-02	20373	2018/10/28	2019/10/27
○	Four Balanced Telecom Pairs ISN	FCC	FCC-TLISN-T8-02	20375	2018/10/28	2019/10/27
○	V-Network	R&S	ESH3-Z6	100211	2018/10/27	2019/10/26
○	V-Network	R&S	ESH3-Z6	100210	2018/10/27	2019/10/26
○	2-Line V-Network	R&S	ESH3-Z5	100049	2018/10/27	2019/10/26

● Radiated Emission-6th test site						
Used	Test Equipment	Manufacturer	Model No.	Serial No.	Last Cal. Date (YY-MM-DD)	Next Cal. Date (YY-MM-DD)
●	Semi-Anechoic Chamber	Albatross projects	SAC-3m-02	N/A	2018/09/30	2021/09/29
●	EMI Test Receiver	R&S	ESCI	100900	2018/10/28	2019/10/27
●	Loop Antenna	R&S	HFH2-Z2	100020	2017/11/20	2020/11/19
●	Ultra-Broadband Antenna	SCHWARZBECK	VULB9163	546	2017/04/05	2020/04/04
●	Pre-Amplifier	SCHWARZBECK	BBV 9742	N/A	2018/11/15	2019/11/14
●	RF Connection Cable	HUBER+SUHNER	N/A	N/A	2018/09/28	2019/09/27
●	RF Connection Cable	HUBER+SUHNER	SUCOFLEX104	501184/4	2018/09/28	2019/09/27
●	Test Software	R&S	ES-K1	N/A	N/A	N/A
●	Turntable	Maturo Germany	TT2.0-1T	N/A	N/A	N/A
●	Antenna Mast	Maturo Germany	CAM-4.0-P-12	N/A	N/A	N/A

● Radiated emission-7th test site						
Used	Test Equipment	Manufacturer	Model No.	Serial No.	Last Cal. Date (YY-MM-DD)	Next Cal. Date (YY-MM-DD)
●	Semi-Anechoic Chamber	Albatross projects	SAC-3m-01	N/A	2018/09/30	2021/09/29
●	Spectrum Analyzer	R&S	FSP40	100597	2018/10/27	2019/10/26
●	Horn Antenna	SCHWARZBECK	9120D	1011	2017/03/27	2020/03/26
●	Pre-amplifier	BONN	BLWA0160-2M	1811887	2018/11/14	2019/11/13
●	Pre-amplifier	CD	PAP-0102	12004	2018/11/14	2019/11/13
●	Broadband Pre-amplifier	SCHWARZBECK	BBV 9718	9718-248	2019/04/26	2020/04/25
●	RF Connection Cable	HUBER+SUHNER	RE-7-FH	N/A	2018/11/15	2019/11/14
●	RF Connection Cable	HUBER+SUHNER	RE-7-FL	N/A	2018/11/15	2019/11/14
●	Test Software	Audix	E3	N/A	N/A	N/A
●	Turntable	Maturo Germany	TT2.0-1T	N/A	N/A	N/A
●	Antenna Mast	Maturo Germany	CAM-4.0-P-12	N/A	N/A	N/A

● RF Conducted Method						
Used	Test Equipment	Manufacturer	Model No.	Serial No.	Last Cal. Date (YY-MM-DD)	Next Cal. Date (YY-MM-DD)
●	Signal and spectrum Analyzer	R&S	FSV40	100048	2018/10/28	2019/10/27
●	Spectrum Analyzer	Agilent	N9020A	MY50510187	2018/09/29	2019/09/28
○	OSP	R&S	OSP120	101317	N/A	N/A
○	Radio communication tester	R&S	CMW500	137688-Lv	2018/09/29	2019/09/28
○	Test software	Tonscend	JS1120-1(LTE)	N/A	N/A	N/A
○	Test software	Tonscend	JS1120-2(WIFI)	N/A	N/A	N/A
○	Test software	Tonscend	JS1120-3(WCDMA)	N/A	N/A	N/A
○	Test software	Tonscend	JS1120-4(GSM)	N/A	N/A	N/A

5. TEST CONDITIONS AND RESULTS

5.1. Antenna requirement

Requirement

FCC CFR Title 47 Part 15 Subpart C Section 15.203:

An intentional radiator shall be designed to ensure that no antenna other than that furnished by the responsible party shall be used with the device. The use of a permanently attached antenna or of an antenna that uses a unique coupling to the intentional radiator, the manufacturer may design the unit so that a broken antenna can be replaced by the user, but the use of a standard antenna jack or electrical connector is prohibited.

Refer to statement below for compliance.

The manufacturer may design the unit so that the user can replace a broken antenna, but the use of a standard antenna jack or electrical connector is prohibited. Further, this requirement does not apply to intentional radiators that must be professionally installed.

TEST RESULTS

Passed **Not Applicable**

The directional gain of the antenna less than 6 dBi, please refer to the below antenna photo.

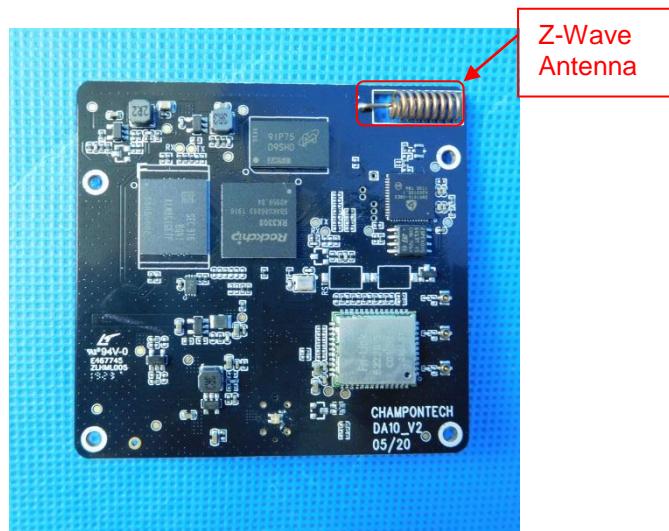

5.2. AC Power Conducted Emissions

LIMIT

FCC CFR Title 47 Part 15 Subpart C Section 15.207:

Frequency range (MHz)	Limit (dBuV)	
	Quasi-peak	Average
0.15-0.5	66 to 56*	56 to 46*
0.5-5	56	46
5-30	60	50

* Decreases with the logarithm of the frequency.

TEST CONFIGURATION

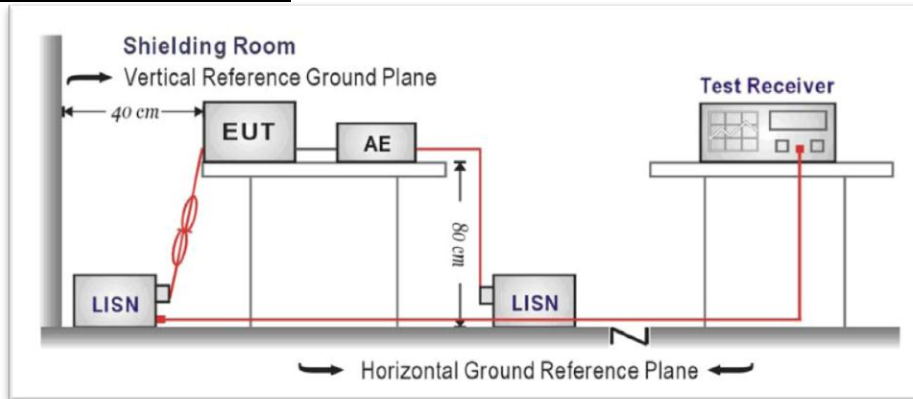

TEST PROCEDURE

1. The EUT was setup according to ANSI C63.10:2013
2. The EUT was placed on a plat form of nominal size, 1 m by 1.5 m, raised 10 cm above the conducting ground plane. The vertical conducting plane was located 40 cm to the rear of the EUT. All other surfaces of EUT were at least 10 cm from any other grounded conducting surface.
3. The EUT and simulators are connected to the main power through a line impedance stabilization network (LISN). The LISN provides a 50ohm / 50uH coupling impedance for the measuring equipment.
4. The peripheral devices are also connected to the main power through a LISN. (Please refer to the block diagram of the test setup and photographs)
5. Each current-carrying conductor of the EUT power cord, except the ground (safety) conductor, was individually connected through a LISN to the input power source.
6. The excess length of the power cord between the EUT and the LISN receptacle were folded back and forth at the center of the lead to form a bundle not exceeding 40 cm in length.
7. Conducted emissions were investigated over the frequency range from 0.15MHz to 30MHz using a receiver bandwidth of 9 kHz.
8. During the above scans, the emissions were maximized by cable manipulation.

TEST MODE:

Please refer to the clause 3.3

TEST RESULTS

Passed Not Applicable

Note:

- 1) Transd= Cable lose + Pulse Limiter Factor + Artificial Mains Factor
- 2) Margin= Limit - Level

Test Line:

L

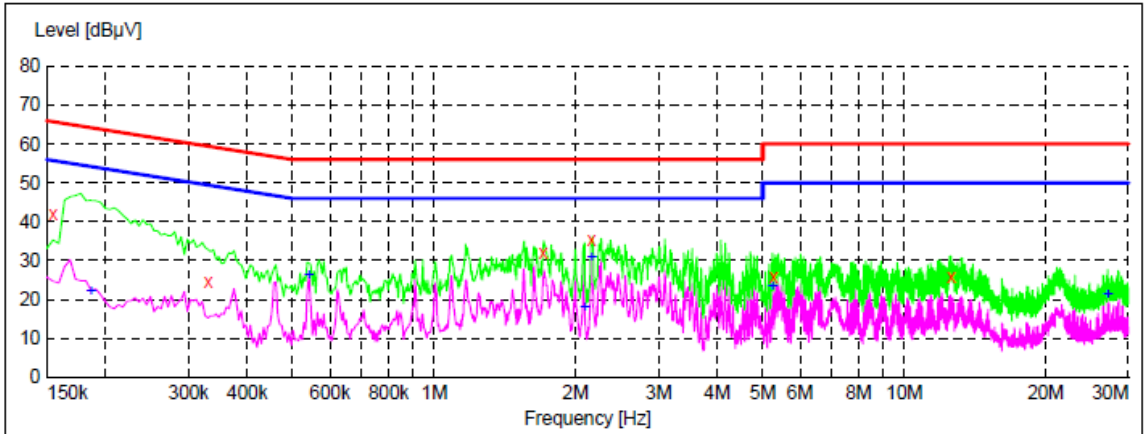

x x x MES GM1907085013_fin

Frequency MHz	Level dBµV	Transd dB	Limit dBµV	Margin dB	Detector	Line	PE
0.154500	42.20	9.9	66	23.6	QP	L1	GND
0.330000	24.60	9.9	60	34.9	QP	L1	GND
1.702500	32.00	9.9	56	24.0	QP	L1	GND
2.161500	35.30	9.9	56	20.7	QP	L1	GND
5.262000	25.80	10.0	60	34.2	QP	L1	GND
12.570000	25.80	10.1	60	34.2	QP	L1	GND

Frequency MHz	Level dBµV	Transd dB	Limit dBµV	Margin dB	Detector	Line	PE
0.186000	22.10	9.9	54	32.1	AV	L1	GND
0.541500	26.10	9.9	46	19.9	AV	L1	GND
2.094000	18.00	9.9	46	28.0	AV	L1	GND
2.161500	30.90	9.9	46	15.1	AV	L1	GND
5.253000	23.50	10.0	50	26.5	AV	L1	GND
27.159000	21.10	10.3	50	28.9	AV	L1	GND

Test Line:

N

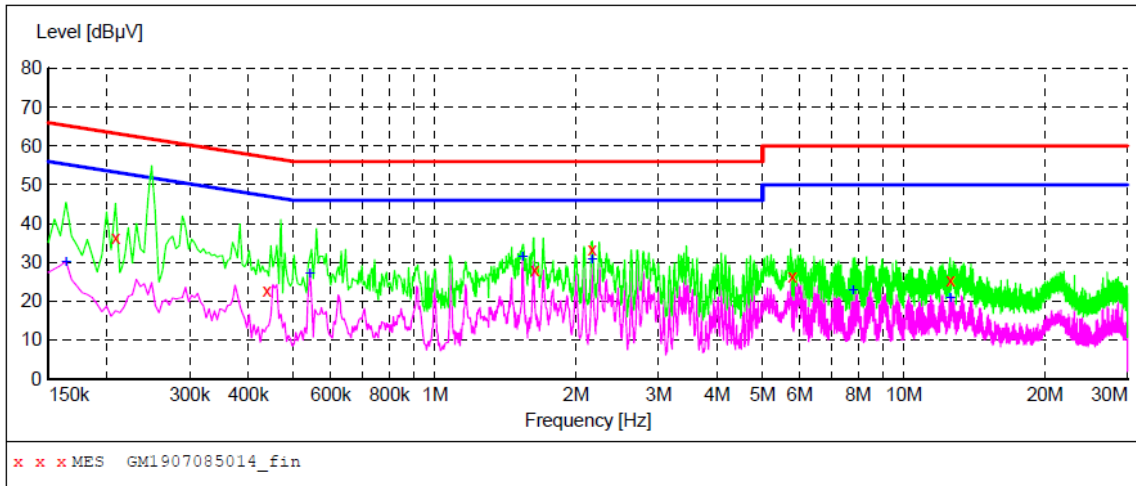

Frequency MHz	Level dBuV	Transd dB	Limit dBuV	Margin dB	Detector	Line	PE
0.208500	36.20	9.9	63	27.1	QP	N	GND
0.438000	22.70	9.9	57	34.4	QP	N	GND
1.630500	28.10	9.9	56	27.9	QP	N	GND
2.161500	33.30	9.9	56	22.7	QP	N	GND
5.784000	26.40	10.0	60	33.6	QP	N	GND
12.570000	25.50	10.1	60	34.5	QP	N	GND
Frequency MHz	Level dBuV	Transd dB	Limit dBuV	Margin dB	Detector	Line	PE
0.163500	29.90	9.9	55	25.4	AV	N	GND
0.541500	27.20	9.9	46	18.8	AV	N	GND
1.540500	31.40	9.9	46	14.6	AV	N	GND
2.166000	30.60	9.9	46	15.4	AV	N	GND
7.795500	22.80	10.0	50	27.2	AV	N	GND
12.574500	20.80	10.1	50	29.2	AV	N	GND

5.3. 20 dB Bandwidth

Limit

Operation frequency range 2400MHz~2483.5MHz.

TEST CONFIGURATION

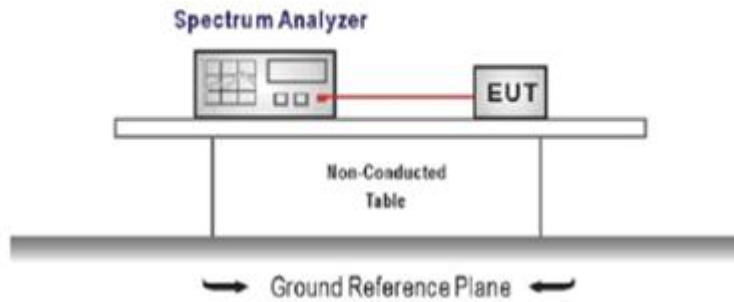

TEST PROCEDURE

1. The transmitter output was connected to the spectrum analyzer through an attenuator, the path loss was compensated to the results for each measurement.
2. Set to the maximum power setting and enable the EUT transmit continuously
3. Use the following spectrum analyzer settings:
Span = approximately 2 to 3 times the 20 dB bandwidth, centered on a hopping channel
RBW \geq 1% of the 20 dB bandwidth, VBW \geq RBW
Sweep = auto, Detector function = peak, Trace = max hold
4. Measure and record the results in the test report.

TEST MODE:

Please refer to the clause 3.3

TEST RESULTS

Passed Not Applicable

Test Channel	20dB Bandwidth (KHz)	Limit (MHz)	Result
CH _L	127.67	-	Pass
CH _H	126.47	-	Pass

CH_L

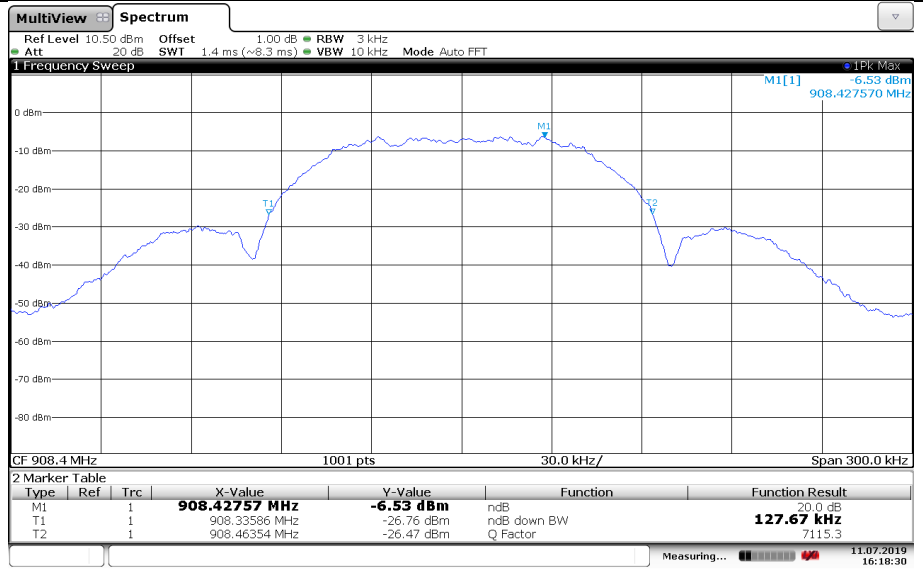

CH_H

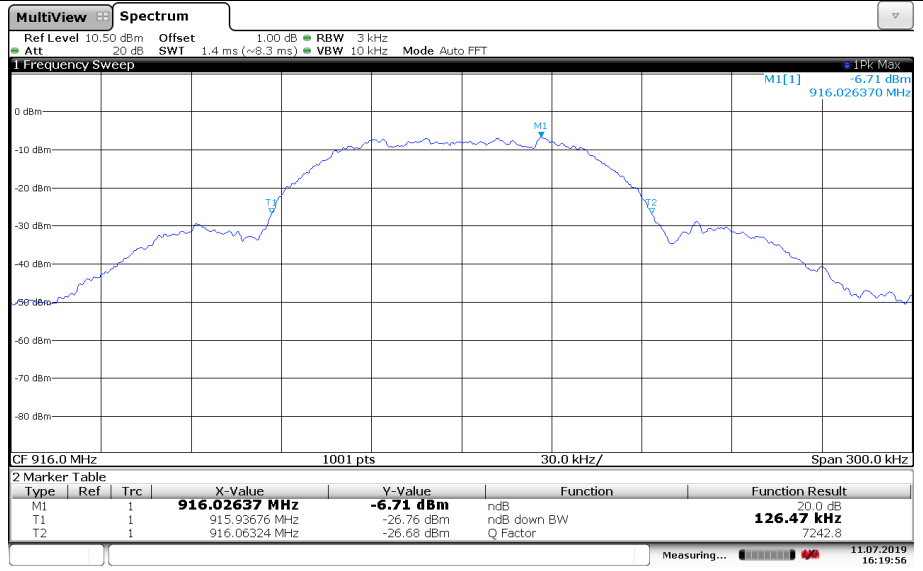

5.4. Radiated field strength of the fundamental signal

LIMIT

Fundamental frequency	Field strength of fundamental (millivolts/meter)	Field strength of harmonics (microvolts/meter)
902-928 MHz	50 (94dBuV/m @3m)	500 (54dBuV/m @3m)
2400-2483.5 MHz	50 (94dBuV/m @3m)	500 (54dBuV/m @3m)
5725-5875 MHz	50 (94dBuV/m @3m)	500 (54dBuV/m @3m)
24.0-24.25 GHz	250 (108dBuV/m @3m)	2500 (68dBuV/m @3m)

Frequencies above 1000 MHz, the field strength limits are based on average limits

TEST CONFIGURATION

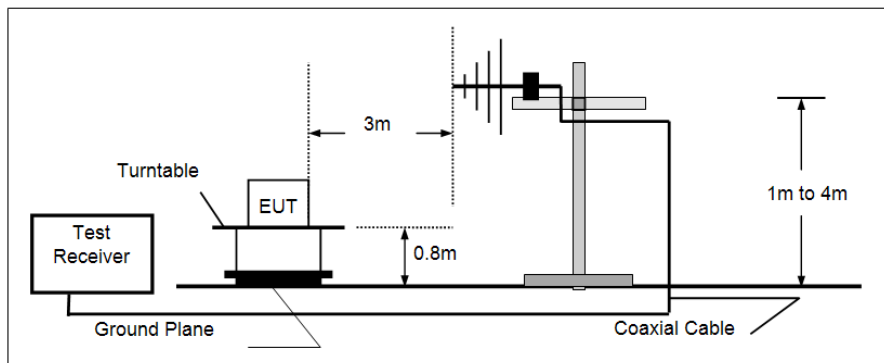

TEST PROCEDURE

1. The EUT was setup and tested according to ANSI C63.10:2013 requirements.
2. The EUT is placed on a turn table which is 0.8 meter above ground. The turn table is rotated 360 degrees to determine the position of the maximum emission level.
3. The EUT was positioned such that the distance from antenna to the EUT was 3 meters.
4. The antenna is scanned from 1 meter to 4 meters to find out the maximum emission level. This is repeated for both horizontal and vertical polarization of the antenna. In order to find the maximum emission, all of the interface cables were manipulated according to ANSI C63.10:2013 on radiated measurement.
5. The receiver set as follow:
RBW=100kHz, VBW=300kHz Peak detector for Peak value.

TEST MODE:

Please refer to the clause 3.3

TEST RESULTS

Passed Not Applicable

Test channel				CHL			
Freq. [MHz]	Reading [dB μ V/m]	Factor [dB]	Level [dB μ V/m]	Limit [dB μ V/m]	Margin [dB]	Polarity	Detector
908.40	53.00	32.23	85.23	94.00	8.77	Vertical	Peak
908.40	60.78	32.23	93.01	94.00	0.99	Horizontal	Peak

Test channel				CHH			
Freq. [MHz]	Reading [dB μ V/m]	Factor [dB]	Level [dB μ V/m]	Limit [dB μ V/m]	Margin [dB]	Polarity	Detector
916.00	51.86	32.26	84.12	94.00	9.88	Vertical	Peak
916.00	59.70	32.26	91.96	94.00	2.04	Horizontal	Peak

5.5. Radiated Spurious Emissions and Bandedge Emission

LIMIT

FCC CFR Title 47 Part 15 Subpart C Section 15.209

Frequency	Limit (dBuV/m @3m)	Value
30MHz~88MHz	40.00	Quasi-peak
88MHz~216MHz	43.50	Quasi-peak
216MHz~960MHz	46.00	Quasi-peak
960MHz~1GHz	54.00	Quasi-peak
Above 1GHz	54.00	Average
	74.00	Peak

TEST CONFIGURATION

- 9 kHz ~ 30 MHz

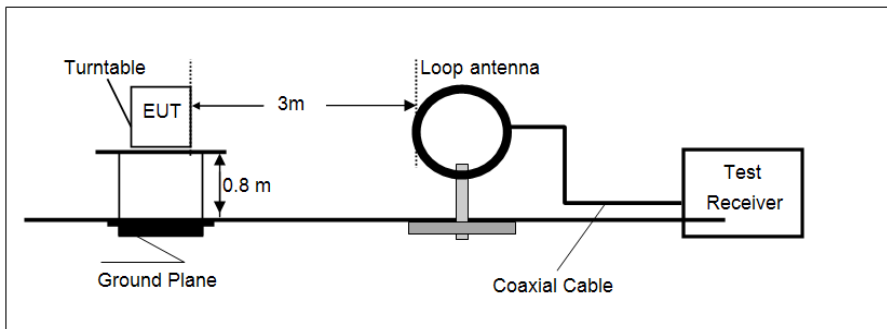

- 30 MHz ~ 1 GHz

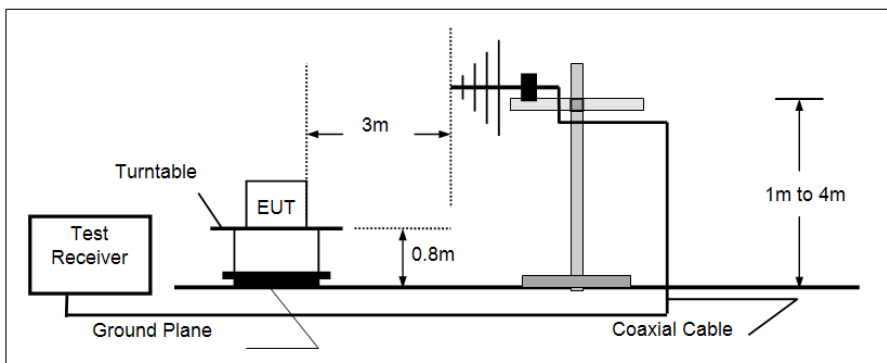

- Above 1 GHz

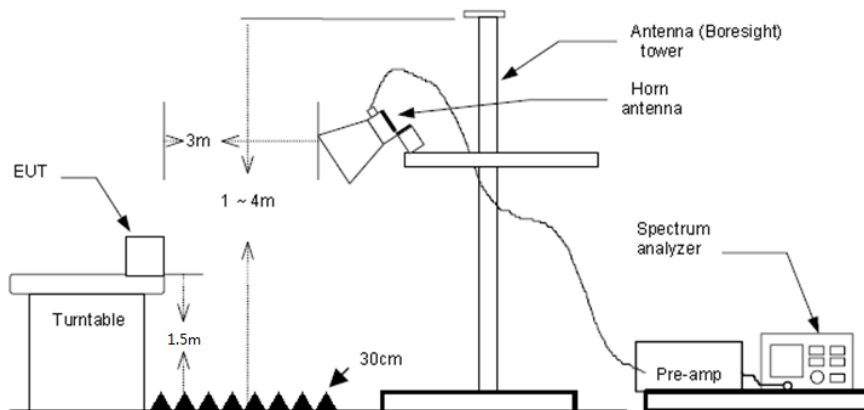

TEST PROCEDURE

1. The EUT was setup and tested according to ANSI C63.10:2013 requirements.
2. The EUT is placed on a turn table which is 0.8 meter above ground for below 1 GHz, and 1.5 m for above 1 GHz. The turn table is rotated 360 degrees to determine the position of the maximum emission level.
3. The EUT was set 3 meters from the receiving antenna, which was mounted on the top of a variable height antenna tower.
4. For each suspected emission, the EUT was arranged to its worst case and then tune the Antenna tower (from 1 m to 4 m) and turntable (from 0 degree to 360 degrees) to find the maximum reading. A pre-amp and a high pass filter are used for the test in order to get better signal level to comply with the guidelines.
5. Set to the maximum power setting and enable the EUT transmit continuously.
6. Use the following spectrum analyzer settings
 - (1) Span shall wide enough to fully capture the emission being measured;
 - (2) Below 1 GHz:
RBW=120 kHz, VBW=300 kHz, Sweep=auto, Detector function=peak, Trace=max hold;
If the emission level of the EUT measured by the peak detector is 3 dB lower than the applicable limit, the peak emission level will be reported. Otherwise, the emission measurement will be repeated using the quasi-peak detector and reported.
 - (3) From 1 GHz to 10th harmonic:
RBW=1MHz, VBW=3MHz Peak detector for Peak value.
RBW=1MHz, VBW=3MHz RMS detector for Average value.

TEST MODE:

Please refer to the clause 3.3

TEST RESULTS

Passed **Not Applicable**

Note:

- 1) Above 1GHz Final Level =Receiver Read level + Antenna Factor + Cable Loss – Preamplifier Factor
- 2) The emission levels of other frequencies are very lower than the limit and not show in test report.

Radiated Spurious Emissions**■ 9 kHz ~ 30 MHz**

The EUT was pre-scanned the frequency band (9 kHz ~ 30 MHz), found the radiated level lower than the limit, so don't show on the report.

■ 30 MHz ~ 1 GHz

Polarization: Vertical

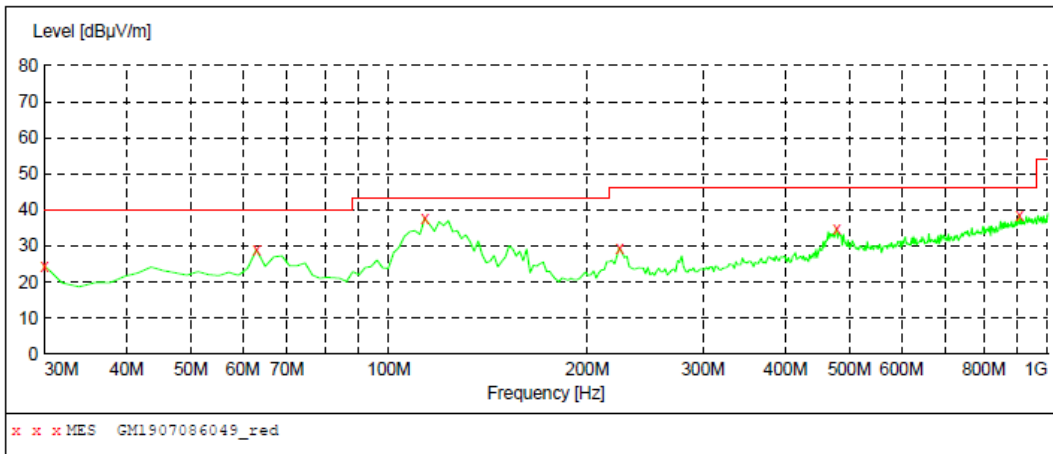

MEASUREMENT RESULT: "GM1907086049_red"

7/8/2019 5:51PM

Frequency MHz	Level dBµV/m	Transd dB	Limit dBµV/m	Margin dB	Det.	Height cm	Azimuth deg	Polarization
30.000000	24.60	-9.4	40.0	15.4	QP	100.0	327.00	VERTICAL
62.980000	29.00	-6.9	40.0	11.0	QP	100.0	274.00	VERTICAL
113.420000	37.70	-7.4	43.5	5.8	QP	100.0	234.00	VERTICAL
224.000000	29.60	-5.8	46.0	16.4	QP	100.0	353.00	VERTICAL
478.140000	34.90	1.1	46.0	11.1	QP	100.0	194.00	VERTICAL
906.880000	38.50	10.5	46.0	7.5	QP	100.0	154.00	VERTICAL

Polarization: Horizontal

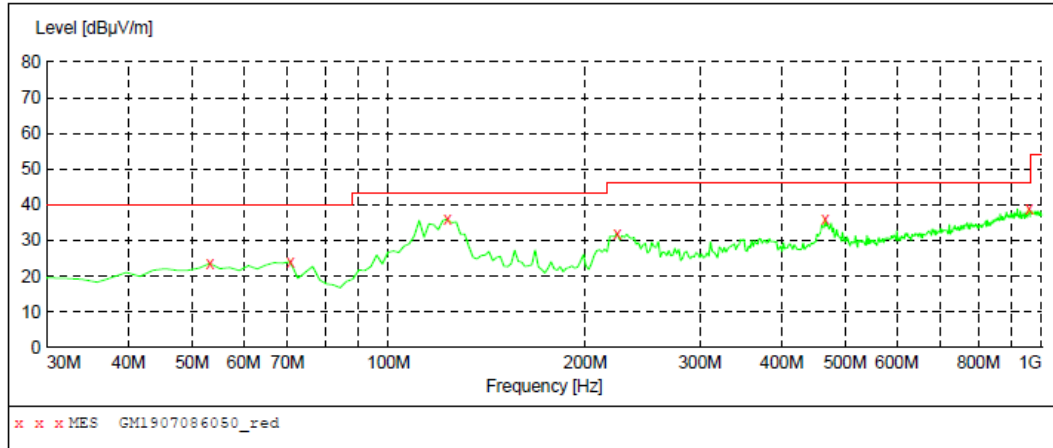

MEASUREMENT RESULT: "GM1907086050_red"

7/8/2019 5:56PM

Frequency MHz	Level dBµV/m	Transd dB	Limit dBµV/m	Margin dB	Det.	Height cm	Azimuth deg	Polarization
53.280000	23.60	-5.1	40.0	16.4	QP	100.0	61.00	HORIZONTAL
70.740000	24.10	-9.4	40.0	15.9	QP	300.0	111.00	HORIZONTAL
123.120000	35.90	-8.9	43.5	7.6	QP	300.0	326.00	HORIZONTAL
224.000000	32.00	-5.8	46.0	14.0	QP	100.0	232.00	HORIZONTAL
466.500000	35.90	0.8	46.0	10.1	QP	100.0	125.00	HORIZONTAL
957.320000	38.90	10.9	46.0	7.1	QP	100.0	153.00	HORIZONTAL

■ Above 1 GHz

Test channel				CH _L			
Freq. [MHz]	Reading [dB μ V/m]	Factor [dB]	Level [dB μ V/m]	Limit [dB μ V/m]	Margin [dB]	Polarity	Detector
1290.8125	36.67	-5.59	31.08	74.00	42.92	Vertical	PK
1816.6250	48.23	-5.80	42.43	74.00	31.57	Vertical	PK
2172.0625	37.55	-3.26	34.29	74.00	39.71	Vertical	PK
2724.3125	41.93	0.95	42.88	74.00	31.12	Vertical	PK
3632.0000	46.13	1.49	47.62	74.00	26.38	Vertical	PK
4673.3438	28.32	6.22	34.54	74.00	39.46	Vertical	PK
1816.6250	46.72	-5.80	40.92	74.00	33.08	Horizontal	PK
2192.6250	34.66	-3.05	31.61	74.00	42.39	Horizontal	PK
2724.3125	42.00	0.95	42.95	74.00	31.05	Horizontal	PK
3632.0000	41.06	1.49	42.55	74.00	31.45	Horizontal	PK
5147.7500	29.58	8.89	38.47	74.00	35.53	Horizontal	PK

Test channel				CH _H			
Freq. [MHz]	Reading [dB μ V/m]	Factor [dB]	Level [dB μ V/m]	Limit [dB μ V/m]	Margin [dB]	Polarity	Detector
1724.0938	38.98	-6.03	32.95	74.00	41.05	Vertical	PK
1831.3125	43.74	-5.81	37.93	74.00	36.07	Vertical	PK
1992.8750	36.06	-4.78	31.28	74.00	42.72	Vertical	PK
2395.3125	46.48	-2.42	44.06	74.00	29.94	Vertical	PK
2747.8125	40.48	1.31	41.79	74.00	32.21	Vertical	PK
4193.0625	33.25	3.78	37.03	74.00	36.97	Vertical	PK
1599.2500	44.81	-6.28	38.53	74.00	35.47	Horizontal	PK
1791.6563	51.78	-5.83	45.95	74.00	28.05	Horizontal	PK
2398.2500	46.15	-2.42	43.73	74.00	30.27	Horizontal	PK
2598.0000	43.21	-1.35	41.86	74.00	32.14	Horizontal	PK
2747.8125	37.29	1.31	38.60	74.00	35.40	Horizontal	PK
6412.3438	37.68	11.43	49.11	74.00	24.89	Horizontal	PK

Remark:

1. Final Level = Reading level + Factor
2. The peak level is lower than average limit(54dBuV/m), this data is the too weak instrument of signal is unable to test.
3. The emission levels of other frequencies are very lower than the limit and not show in test report.

Bandedge Emission

Test channel				CH _L			
Freq. [MHz]	Reading [dBμV/m]	Factor [dB]	Level [dBμV/m]	Limit [dBμV/m]	Margin [dB]	Polarity	Detector
902.00	12.14	32.20	44.34	46.00	1.66	Horizontal	QP
902.00	13.20	32.20	45.40	46.00	0.60	Horizontal	QP
902.00	11.85	32.20	44.05	46.00	1.95	Vertical	QP
902.00	12.21	32.20	44.41	46.00	1.59	Vertical	QP

Test channel				CH _H			
Freq. [MHz]	Reading [dBμV/m]	Factor [dB]	Level [dBμV/m]	Limit [dBμV/m]	Margin [dB]	Polarity	Detector
928.00	12.42	32.31	44.62	46.00	1.38	Horizontal	QP
928.00	12.61	32.31	44.81	46.00	1.19	Horizontal	QP
928.00	11.96	32.31	44.16	46.00	1.84	Vertical	QP
928.00	12.07	32.31	44.27	46.00	1.73	Vertical	QP

Remark:

1. Final Level = Reading level + Factor
2. The peak level is lower than limit, this data is the too weak instrument of signal is unable to test.
3. The emission levels of other frequencies are very lower than the limit and not show in test report.