

APPLICATION CERTIFICATION FCC Part 22&24
On Behalf of
SHENZHEN COBAN ELECTRONICS CO., LTD

GPS TRACKER

Model No.: GPS-103, GPS-103A, GPS-103B, GPS-103C, GPS-103D,
GPS-103E, GPS-103F, GPS-103G, GPS-103H, GPS-103I

FCC ID: 2ATUK-GPS-103

Prepared for : SHENZHEN COBAN ELECTRONICS CO., LTD
Address : 5/F, Block 22, Wisdomland Business Park, Guankou
2nd Road, Nantou, Nanshan District, Shenzhen,
Guangdong, China. 518052.
Prepared by : Shenzhen Accurate Technology Co., Ltd.
Address : 1/F., Building A, Changyuan New Material Port,
Science & Industry Park, Nanshan District,
Shenzhen, Guangdong, P.R. China

Tel: (0755) 26503290
Fax: (0755) 26503396

Report No. : ATE20191546
Date of Test : June 10, 2019-July 24, 2019
Date of Report : July 25, 2019

TABLE OF CONTENTS

Description	Page
Test Report Certification	
1. GENERAL INFORMATION	5
1.1. Description of Device (EUT).....	5
1.2. Description of Test Facility	6
1.3. Measurement Uncertainty	6
2. MEASURING DEVICE AND TEST EQUIPMENT	7
3. SYSTEM TEST CONFIGURATION	8
3.1. Justification.....	8
3.2. Configuration of Test Setup.....	8
3.3. Block Diagram of Test Setup.....	8
4. TEST PROCEDURES AND RESULTS	9
5. BANDWIDTH MEASUREMENT	10
5.1. Block Diagram of Test Setup.....	10
5.2. Applicable Standard.....	10
5.3. Operating Condition of EUT	10
5.4. Test Procedure	10
5.5. Test Result	11
6. RF OUTPUT POWER.....	18
6.1. Block Diagram of Test Setup.....	18
6.2. Applicable Standard.....	18
6.3. Operating Condition of EUT	19
6.4. Test Procedure	19
6.5. Test Result	19
7. SPURIOUS EMISSIONS AT ANTENNA TERMINALS.....	21
7.1. Block Diagram of Test Setup.....	21
7.2. Applicable Standard.....	21
7.3. EUT Configuration on Measurement	21
7.4. Operating Condition of EUT	21
7.5. Test Procedure	21
7.6. Test Result	22
8. BAND EDGE COMPLIANCE TEST	29
8.1. Block Diagram of Test Setup.....	29
8.2. Applicable Standard.....	29
8.3. Operating Condition of EUT	29
8.4. Test Procedure	29
8.5. Test Result	30
9. RADIATED SPURIOUS EMISSION TEST	33
9.1. Block Diagram of Test Setup.....	33
9.2. Applicable Standard.....	34
9.3. Restricted bands of operation	35
9.4. Configuration of EUT on Measurement	35
9.5. Operating Condition of EUT	36
9.6. Test Procedure	36

- 9.7. The Field Strength of Radiation Emission Measurement Results36
- 10. FREQUENCY STABILITY 40**
 - 10.1. Block Diagram of Test Setup.....40
 - 10.2. The Requirement For Section CFR47 § 2.1055 (a), § 2.1055 (d), §22.355, §24.23540
 - 10.3. Operating Condition of EUT40
 - 10.4. Test Procedure40
 - 10.5. Test Result41
- 11. PEAK TO AVERAGE RATIO 42**
 - 11.1. Block Diagram of Test Setup.....42
 - 11.2. The LIMITS OF PEAK TO AVERAGE RATIO MEASUREMENT.....42
 - 11.3. Operating Condition of EUT42
 - 11.4. Test Procedure42
 - 11.5. Test Result42
- 12. ANTENNA REQUIREMENT..... 44**
 - 12.1. The Requirement44
 - 12.2. Antenna Construction44

Test Report Certification

Applicant& address : SHENZHEN COBAN ELECTRONICS CO., LTD
5/F, Block 22, Wisdomland Business Park, Guankou 2nd Road,
Nantou, Nanshan District, Shenzhen, Guangdong, China. 518052.

Manufacturer& address : Shenzhen Coban Electronics Co., Ltd.
6/F, C2, Xinqiao Industrial Park, Tongfuyu Industrial Area, Xinhe
Avenue, Gonghe Community, Shajing Sub-District, Bao'an
District, Shenzhen, Guangdong, China.

Product : GPS TRACKER

Model No. : GPS-103, GPS-103A, GPS-103B, GPS-103C, GPS-103D,
GPS-103E, GPS-103F, GPS-103G, GPS-103H, GPS-103I

Trade name :  (DI QIU TU XING)

Measurement Procedure Used:

FCC Rules and Regulations Part 22 Subpart H - Public Mobile Services
Part 24 Subpart E - Personal Communication Services
FCC part 2
ANSI C63.26:2015
TIA/EIA 603 E March 2016
KDB 971168 D01 Power Meas License Digital Systems v03r01

The device described above is tested by Shenzhen Accurate Technology Co., Ltd. to determine the maximum emission levels emanating from the device. The maximum emission levels are compared to the FCC Part 22H&24E limits. The measurement results are contained in this test report and Shenzhen Accurate Technology Co., Ltd. is assumed full responsibility for the accuracy and completeness of these measurements. Also, this report shows that the Equipment Under Test (EUT) is to be technically compliant with the FCC requirements.

This report applies to above tested sample only. This report shall not be reproduced in part without written approval of Shenzhen Accurate Technology Co., Ltd.

Date of Test : June 10, 2019-July 24, 2019
Date of Report : July 25, 2019

Prepared by : 
(Tim Liang, Engineer)

Approved & Authorized Signer : 
(Sean Liu, Manager)

1. GENERAL INFORMATION

1.1. Description of Device (EUT)

EUT	: GPS TRACKER
Model Number	: GPS-103, GPS-103A, GPS-103B, GPS-103C, GPS-103D, GPS-103E, GPS-103F, GPS-103G, GPS-103H, GPS-103I
Type of Modulation	: QPSK
Number of channels	: FDD V: 826.4-846.6 MHz 278 Channels FDD II : 1852.4-1907.6 MHz 103 Channels
Frequency	: UMTS FDD Bands: II/V, HSDPA, HSUPA
Antenna Gain	: 0dBi
Type of Antenna	: External Antenna
Power Supply	: 1. DC 12-24V(Powered by Harness port) 2. DC 3.7V(Powered by battery)
HW VERSION	: 103-3-V1.0
SW VERSION	: 103-3-V1.0-190513
Applicant Address	: Shenzhen Coban Electronics Co., Ltd. 5/F, Block 22, Wisdomland Business Park, Guankou 2nd Road, Nantou, Nanshan District, Shenzhen, Guangdong, China. 518052.
Manufacturer Address	: Shenzhen Coban Electronics Co., Ltd. 6/F, C2, Xinqiao Industrial Park, Tongfuyu Industrial Area, Xinhe Avenue, Gonghe Community, Shajing Sub-District, Bao'an District, Shenzhen, Guangdong, China.
Date of sample received	: June 10, 2019
Date of Test	: June 10, 2019-July 24, 2019
Sample Number	: 1900723

1.2. Description of Test Facility

EMC Lab	Recognition of accreditation by Federal Communications Commission (FCC) The Designation Number is CN1189 The Registration Number is 708358
	Listed by Innovation, Science and Economic Development Canada (ISED) The Registration Number is 5077A-2
	Accredited by China National Accreditation Service for Conformity Assessment (CNAS) The Registration Number is CNAS L3193
	Accredited by American Association for Laboratory Accreditation (A2LA) The Certificate Number is 4297.01
Name of Firm	: Shenzhen Accurate Technology Co., Ltd
Site Location	: 1/F., Building A, Changyuan New Material Port, Science & Industry Park, Nanshan District, Shenzhen, Guangdong, P.R. China

1.3. Measurement Uncertainty

Conducted Emission Expanded Uncertainty (Mains ports, 9kHz-30MHz)	=	2.72dB, k=2
Radiated emission expanded uncertainty (9kHz-30MHz)	=	2.66dB, k=2
Radiated emission expanded uncertainty (30MHz-1000MHz)	=	4.28dB, k=2
Radiated emission expanded uncertainty (1G-18GHz)	=	4.98dB, k=2
Radiated emission expanded uncertainty (18G-26.5GHz)	=	5.06dB, k=2

2. MEASURING DEVICE AND TEST EQUIPMENT

Table 1: List of Test and Measurement Equipment

Kind of equipment	Manufacturer	Type	S/N	Calibrated dates	Calibrated until
EMI Test Receiver	Rohde&Schwarz	ESCS30	100307	Jan. 05, 2019	Jan. 04, 2020
EMI Test Receiver	Rohde&Schwarz	ESPI3	101526/003	Jan. 05, 2019	Jan. 04, 2020
Spectrum Analyzer	Agilent	E7405A	MY45115511	Jan. 05, 2019	Jan. 04, 2020
Pre-Amplifier	Rohde&Schwarz	CBLU118354 0-01	3791	Jan. 05, 2019	Jan. 04, 2020
Loop Antenna	Schwarzbeck	FMZB1516	1516131	Jan. 05, 2019	Jan. 04, 2020
Bilog Antenna	Schwarzbeck	VULB9163	9163-194	Jan. 05, 2019	Jan. 04, 2020
Bilog Antenna	Schwarzbeck	VULB9163	9163-323	Jan. 05, 2019	Jan. 04, 2020
Horn Antenna	Schwarzbeck	BBHA9120D	9120D-655	Jan. 05, 2019	Jan. 04, 2020
Horn Antenna	Schwarzbeck	BBHA9170	9170-359	Jan. 05, 2019	Jan. 04, 2020
LISN	Rohde&Schwarz	ESH3-Z5	100305	Jan. 05, 2019	Jan. 04, 2020
LISN	Schwarzbeck	NSLK8126	8126431	Jan. 05, 2019	Jan. 04, 2020
Highpass Filter	Wainwright Instruments	WHKX3.6/18 G-10SS	N/A	Jan. 05, 2019	Jan. 04, 2020
Band Reject Filter	Wainwright Instruments	WRCG2400/2 485-2375/2510 -60/11SS	N/A	Jan. 05, 2019	Jan. 04, 2020
Wideband Radio Communication Tester	Rohde&Schwarz	CMW500	154606	Jan. 05, 2019	Jan. 04, 2020

3. SYSTEM TEST CONFIGURATION

3.1. Justification

The EUT was configured for testing according to TIA/EIA-603-E.
The final qualification test was performed with the EUT operating at normal mode.

3.2. Configuration of Test Setup

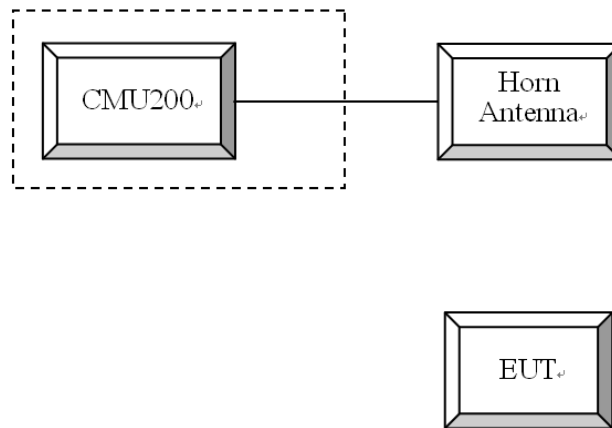

3.3. Block Diagram of Test Setup

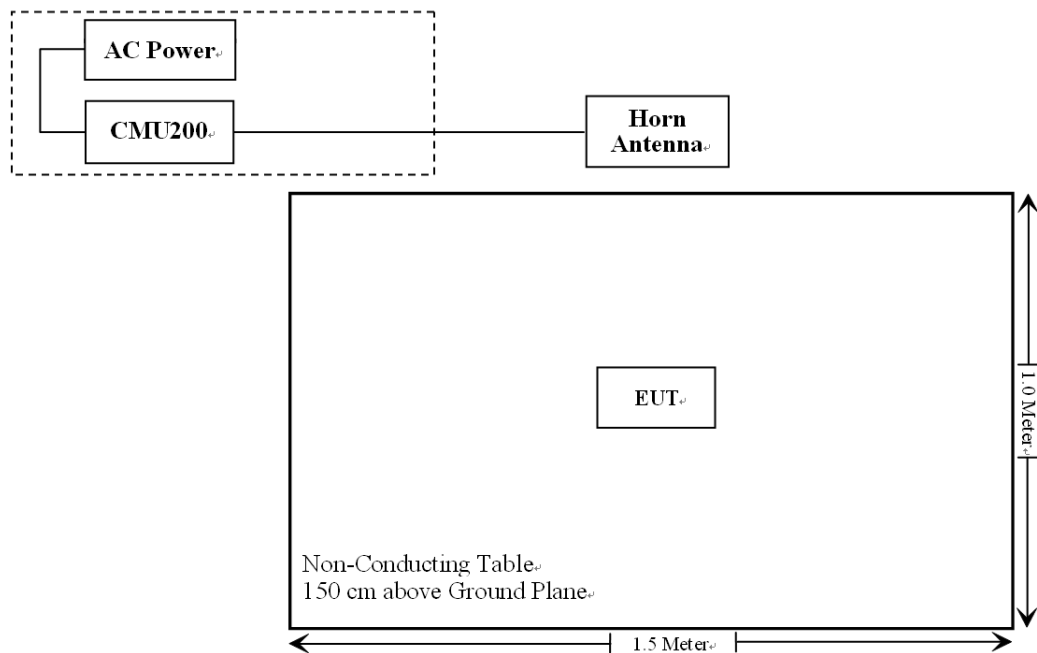

4. TEST PROCEDURES AND RESULTS

FCC Rules	Description of Test	Result
Section 15.207	N/A	N/A
§2.1046; § 22.913 (a); § 24.232 (c)	RF Output Power	Compliant
§ 2.1049; § 22.905 § 22.917; § 24.238	99% & -26 dB Occupied Bandwidth	Compliant
§ 2.1051, § 22.917 (a); § 24.238 (a)	Spurious Emissions at Antenna Terminal	Compliant
§ 2.1053 § 22.917 (a); § 24.238 (a)	Field Strength of Spurious Radiation	Compliant
§ 22.917 (a); § 24.238 (a)	Out of band emission, Band Edge	Compliant
§ 2.1055 § 22.355; § 24.235	Frequency stability vs. temperature Frequency stability vs. voltage	Compliant
KDB 971168 D01 Power Meas License Digital Systems v03r01	Peak to average ratio	Compliant

Note: The power supply mode of the EUT is DC 3.7V(battery) or DC 12-24V(Harness port), According to the FCC standard requirements, conducted emission is not applicable.

5. BANDWIDTH MEASUREMENT

5.1. Block Diagram of Test Setup

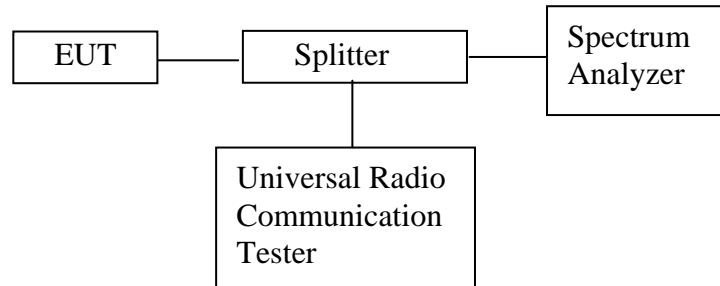

5.2. Applicable Standard

FCC § 2.1049

The occupied bandwidth, that is the frequency bandwidth such that, below its lower and above its upper frequency limits, the mean powers radiated are each equal to 0.5 percent of the total mean power radiated by a given emission shall be measured under the following conditions as applicable.

(h) Transmitters employing digital modulation techniques-when modulated by an input signal such that its amplitude and symbol rate represent the maximum rated conditions under which the equipment will be operated.

5.3. Operating Condition of EUT

5.3.1. Setup the EUT and simulator as shown as Section 5.1.

5.3.2. Turn on the power of all equipment.

5.3.3. Let the EUT work in TX modes measure it. The transmit frequency are 826.4-846.6MHz and 1852.4-1907.6MHz. We select 826.4MHz, 836.6MHz, 846.6MHz and 1852.4MHz, 1880.0MHz, 1907.6MHz TX frequency to transmit.

5.4. Test Procedure

99% occupied bandwidth & -26dB occupied bandwidth test:

1. Set resolution bandwidth (RBW) = 100 kHz.
2. Set the video bandwidth (VBW) $\geq 3 \times$ RBW.
3. Detector = Peak.
4. Trace mode = max hold.
5. Sweep = auto couple.
6. Allow the trace to stabilize.
7. Measurements are to be performed with the EUT set to the low, middle and high channel of each frequency band.

5.5. Test Result

UMTS FDD V Band		
Frequency (MHz)	99% Occupied Bandwidth (MHz)	-26 dBc Bandwidth (MHz)
826.4	4.180	4.740
836.6	4.160	4.680
846.6	4.200	4.780

UMTS FDD II Band		
Frequency (MHz)	99% Occupied Bandwidth (MHz)	-26 dBc Bandwidth (MHz)
1852.4	4.160	4.700
1880.0	4.160	4.720
1907.6	4.160	4.700

The spectrum analyzer plots are attached as below.

UMTS FDD V Band

Occupied Bandwidth

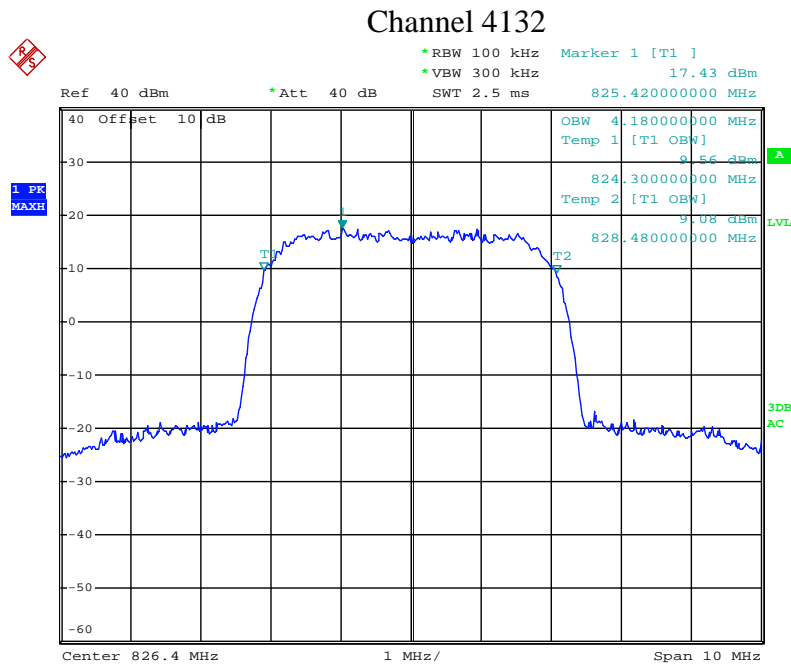

Date: 20.JUN.2019 17:21:23

Channel 4183

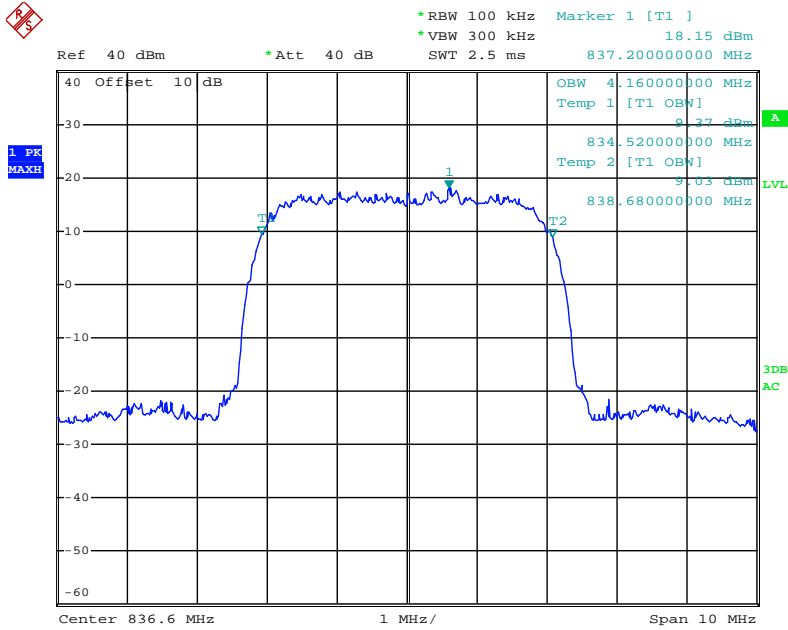

Date: 20.JUN.2019 17:22:57

Channel 4233

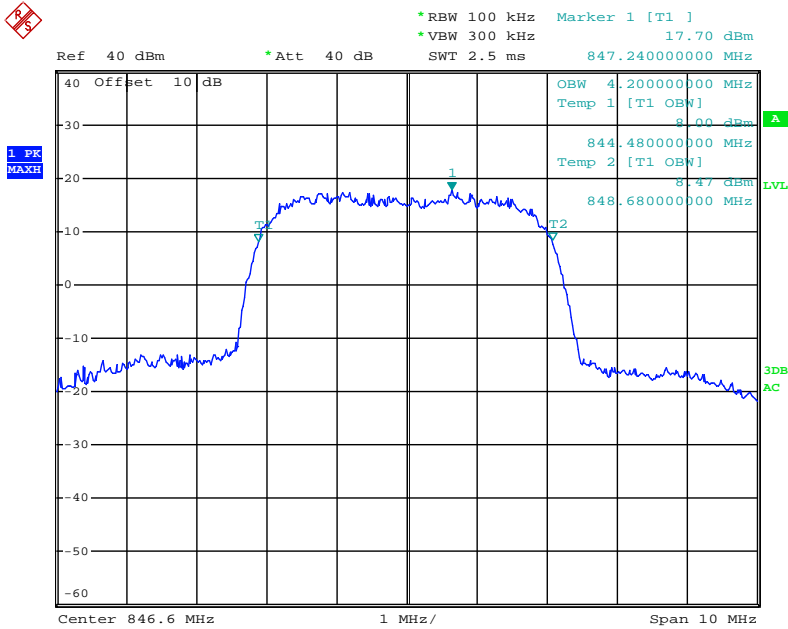

Date: 20.JUN.2019 17:23:24

UMTS FDD II Band

Occupied Bandwidth

Channel 9262

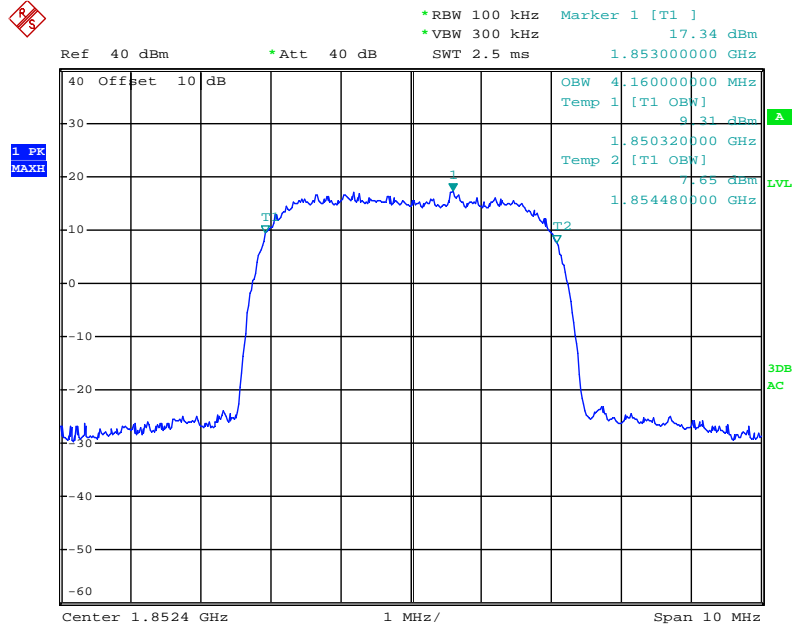

Date: 20.JUN.2019 17:25:57

Channel 9400

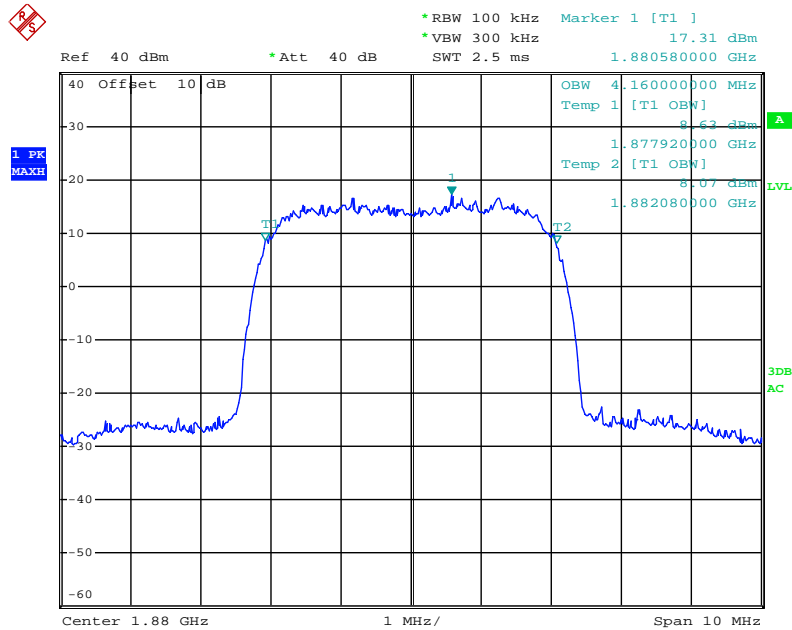

Date: 20.JUN.2019 17:26:36

Channel 9538

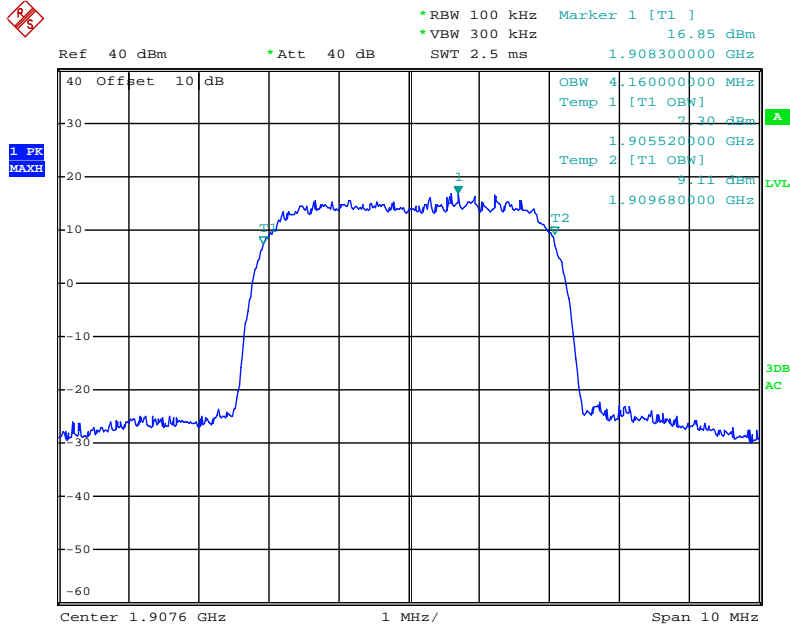

Date: 20.JUN.2019 17:27:45

UMTS FDD V Band

-26 dBc Bandwidth

Channel 4132

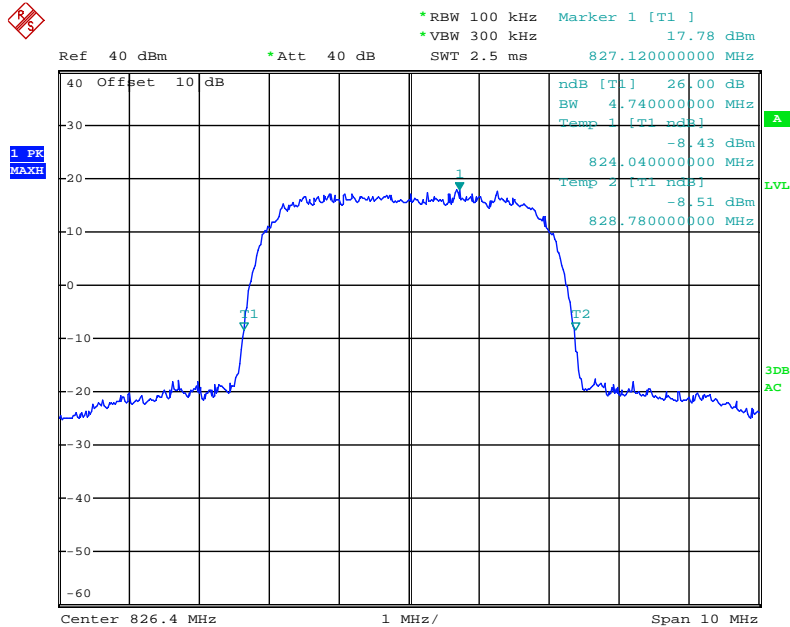

Date: 20.JUN.2019 17:21:56

Channel 4183

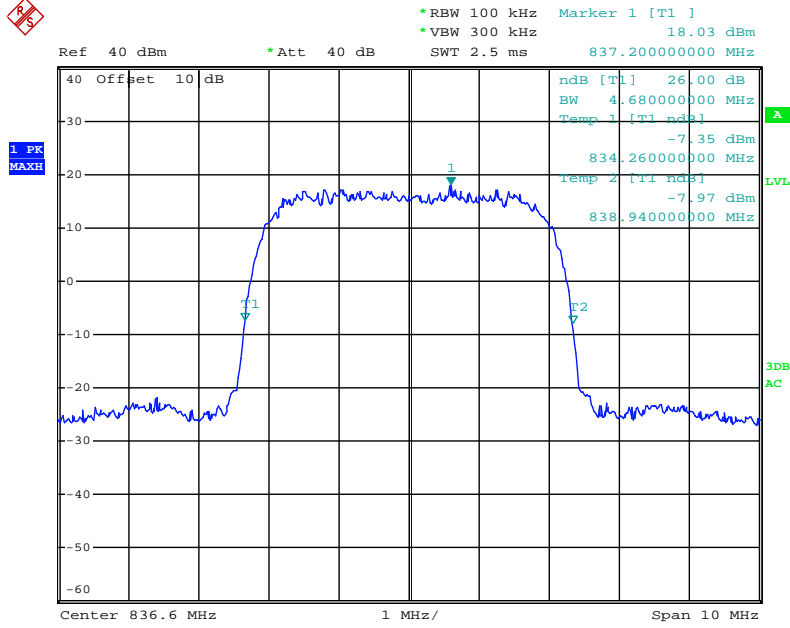

Date: 20.JUN.2019 17:22:31

Channel 4233

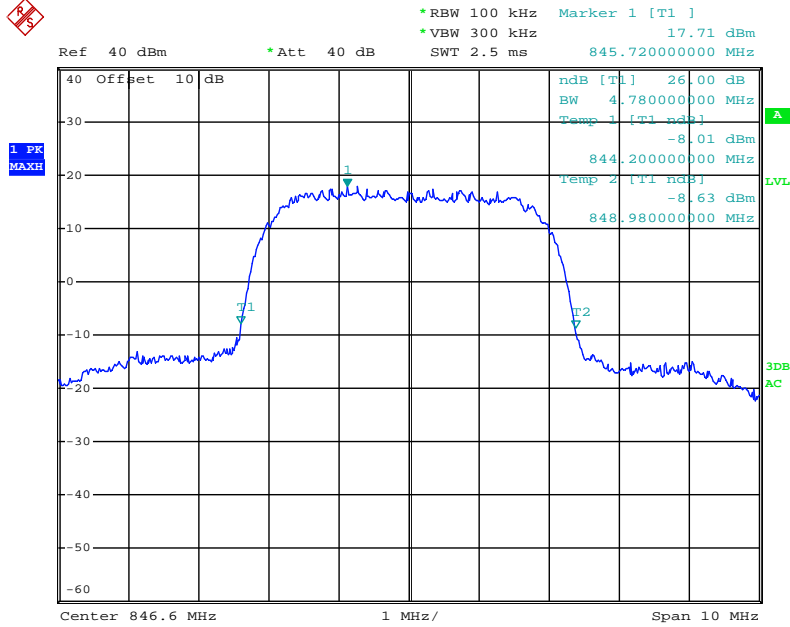

Date: 20.JUN.2019 17:23:57

UMTS FDD II Band

-26 dBc Bandwidth

Channel 9262

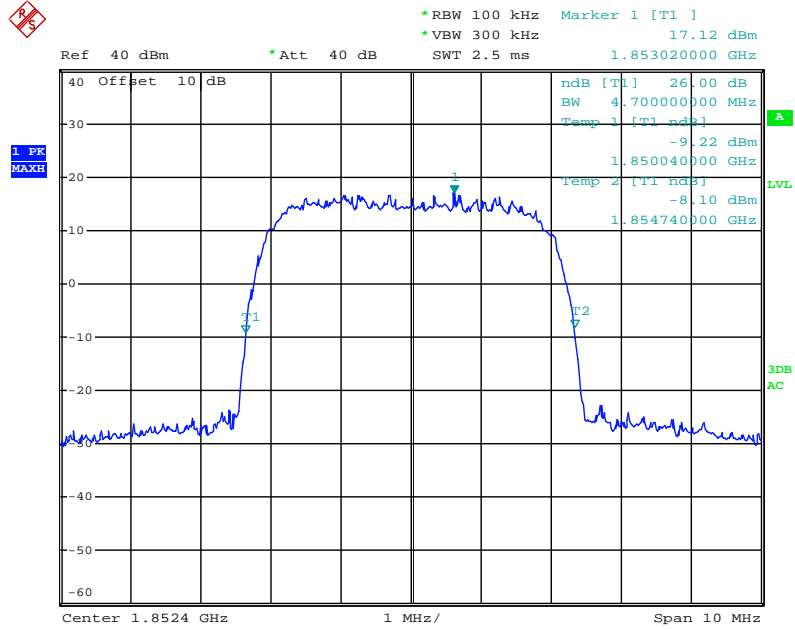

Date: 20.JUN.2019 17:25:03

Channel 9400

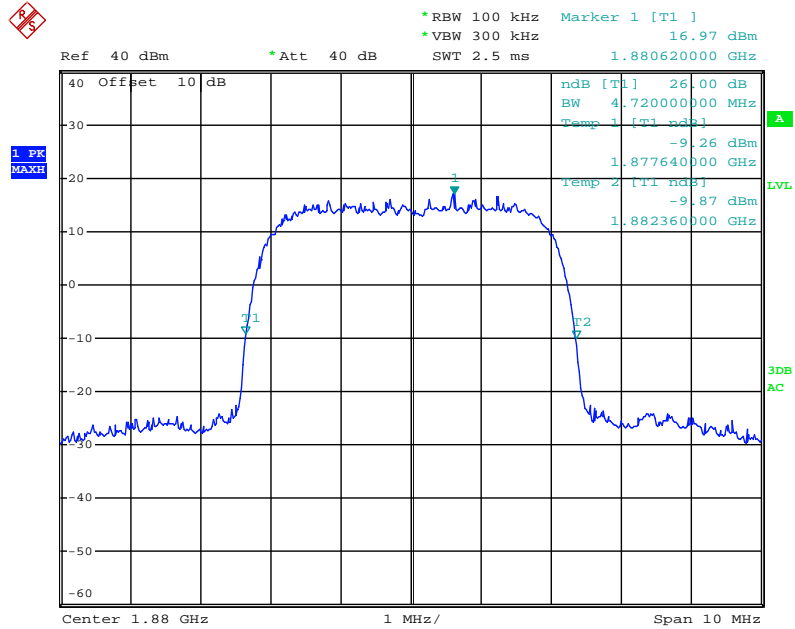

Date: 20.JUN.2019 17:26:52

Channel 9538

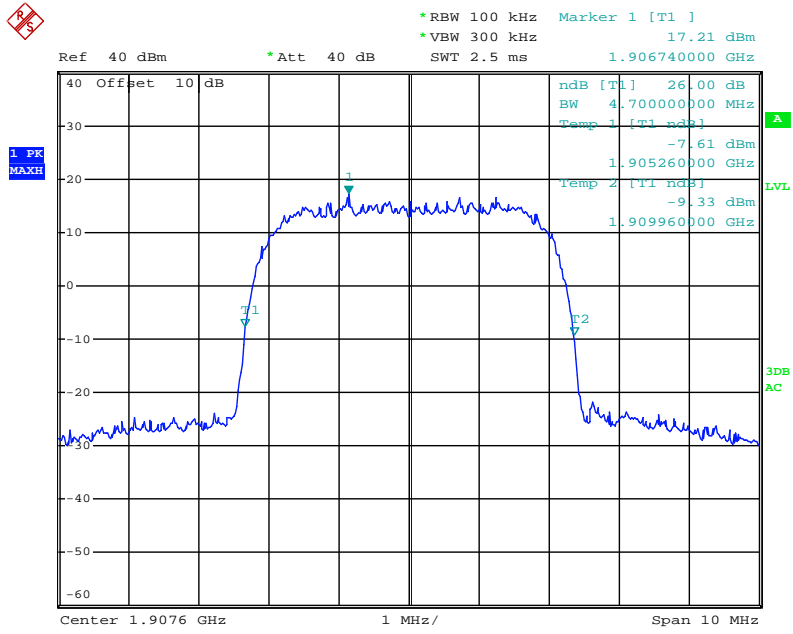

Date: 20.JUN.2019 17:27:22

6. RF OUTPUT POWER

6.1. Block Diagram of Test Setup

Conducted method:

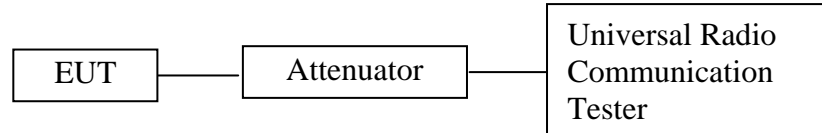

Radiated method:

Frequency range 30MHz – 1000MHz

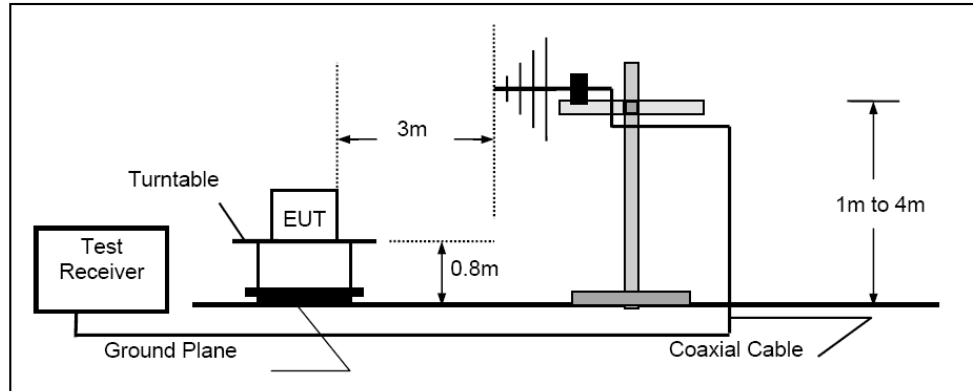

Frequency range above 1GHz-25GHz

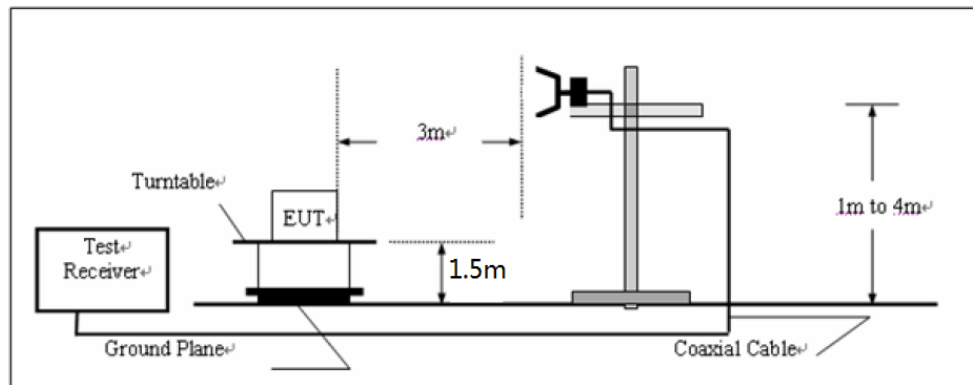

6.2. Applicable Standard

FCC § 22.913(a), § 24.232(b).

6.3. Operating Condition of EUT

6.3.1. Setup the EUT and simulator as shown as Section 6.1.

6.3.2. Turn on the power of all equipment.

6.3.3. Let the EUT work in TX modes measure it. The transmit frequency are 826.4-846.6MHz and 1852.4-1907.6MHz. We select 826.4MHz, 836.6MHz, 846.6MHz and 1852.4MHz, 1880.0MHz, 1907.6MHz TX frequency to transmit.

6.4. Test Procedure

Conducted method:

The RF output of the transmitter was connected to the wireless test set and the spectrum analyzer through sufficient attenuation.

Radiated method(For ERP&EIRP):

1. The transmitter was placed on a wooden turntable, and it was transmitting into a non-radiating load which was also placed on the turntable.
2. The measurement antenna was placed at a distance of 3 meters from the EUT. During the tests, the antenna height and polarization as well as EUT azimuth were varied in order to identify the maximum level of emissions from the EUT. The test was performed by placing the EUT on 3-orthogonal axis.
3. The frequency range up to tenth harmonic of the fundamental frequency was investigated.
4. Remove the EUT and replace it with substitution antenna. A signal generator was connected to the substitution antenna by a non-radiating cable. The absolute levels of the spurious emissions were measured by the substitution.

6.5. Test Result

PASS

Conducted Output Power

Mode	Channel	Frequency (MHz)	Conducted Output Power (dBm)	Limit (dBm)
UMTS FDD V(WCDMA)	4132	826.4	22.52	38.5
	4183	836.6	22.70	38.5
	4233	846.6	22.59	38.5

Mode	Channel	Frequency (MHz)	Conducted Output Power (dBm)	Limit (dBm)
UMTS FDD II(WCDMA)	9262	1852.4	22.19	33
	9400	1880.0	22.42	33
	9538	1907.6	22.16	33

Radiated Power

ERP for UMTS FDD V(WCDMA)

Indicated		Table Angle Degree	Test Antenna		Substituted			Antenna Gain Correction (dBi)	Cable Loss (dB)	Absolute Level (dBm)	Limit (dBm)
Frequency (MHz)	S.A. Reading (dBμV/m)		Height (m)	Polar (H/V)	Frequency (MHz)	S.G. Level (dBm)	Polar (H/V)				
Low Channel											
826.4	89.23	129	1.2	V	826.4	21.7	V	0	0.9	20.8	38.45
826.4	80.81	107	1.6	H	826.4	16.5	H	0	0.9	15.6	38.45
Middle Channel											
836.6	89.18	135	1.3	V	836.6	21.0	V	0	0.9	20.1	38.45
836.6	80.22	311	1.5	H	836.6	16.3	H	0	0.9	15.4	38.45
High Channel											
846.6	88.83	114	1.2	V	846.6	21.2	V	0	0.9	20.3	38.45
846.6	80.95	202	1.5	H	846.6	16.4	H	0	0.9	15.5	38.45

EIRP for UMTS FDD II(WCDMA)

Indicated		Table Angle Degree	Test Antenna		Substituted			Antenna Gain Correction (dBi)	Cable Loss (dB)	Absolute Level (dBm)	Limit (dBm)
Frequency (MHz)	S.A. Reading (dBμV/m)		Height (m)	Polar (H/V)	Frequency (MHz)	S.G. Level (dBm)	Polar (H/V)				
Low Channel											
1852.4	86.52	125	1.1	V	1852.4	15.4	V	6.2	1.1	20.5	33
1852.4	79.16	213	1.5	H	1852.4	10.4	H	6.2	1.1	15.5	33
Middle Channel											
1880.0	86.54	156	1.7	V	1880.0	15.5	V	6.2	1.1	20.6	33
1880.0	78.64	320	1.6	H	1880.0	9.9	H	6.2	1.1	15.0	33
High Channel											
1907.6	85.67	232	2.0	V	1907.6	14.5	V	6.2	1.1	19.6	33
1907.6	77.79	189	2.0	H	1907.6	9.3	H	6.2	1.1	14.4	33

7. SPURIOUS EMISSIONS AT ANTENNA TERMINALS

7.1. Block Diagram of Test Setup

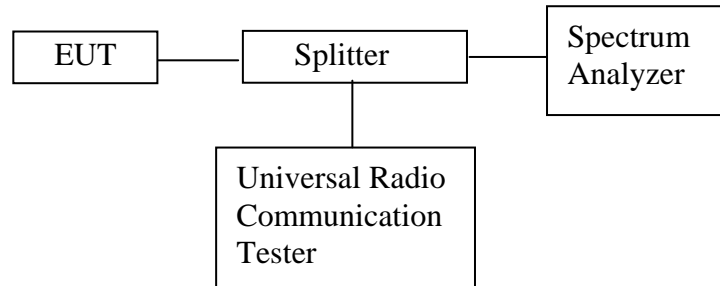

7.2. Applicable Standard

FCC §2.1051, §22.917, §24.238.

7.3. EUT Configuration on Measurement

The equipment are installed on the emission Measurement to meet the commission requirements and operating regulations in a manner which tends to maximize its emission characteristics in normal application.

7.4. Operating Condition of EUT

7.4.1. Setup the EUT and simulator as shown as Section 7.1.

7.4.2. Turn on the power of all equipment.

7.4.3. Let the EUT work in TX modes measure it. The transmit frequency are 826.4-846.6MHz and 1852.4-1907.6MHz. We select 826.4MHz, 836.6MHz, 846.6MHz and 1852.4MHz, 1880.0MHz, 1907.6MHz TX frequency to transmit.

7.5. Test Procedure

7.5.1. Set the EUT to its maximum power at the required channel.

7.5.2. Measurements are to be performed with the EUT set to the low, middle and high channel of each frequency band. Measure and record all spurious emissions up to the tenth harmonic of the carrier frequency.

7.5.3. Set the RBW=100 kHz , VBW=300 kHz below 1GHz and the RBW=1MHz , VBW=3MHz above 1GHz.

7.5.4. Detector = peak-Max hold.

7.5.5. Sweep time = auto.

7.5.6. Allow trace to fully stabilize.

7.6. Test Result

The spectrum analyzer plots are attached as below.

UMTS FDD V

30MHz – 9GHz (Channel 4132)

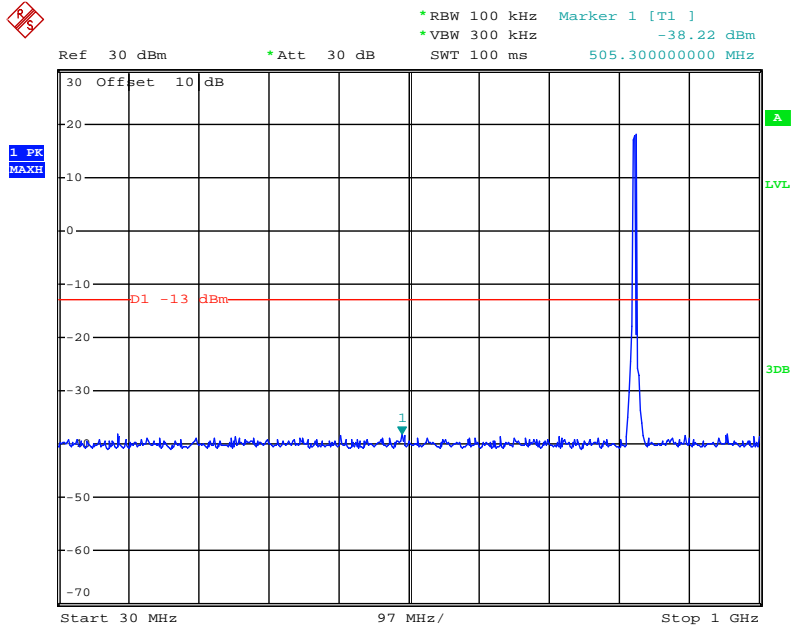

Date: 20.JUN.2019 18:00:20

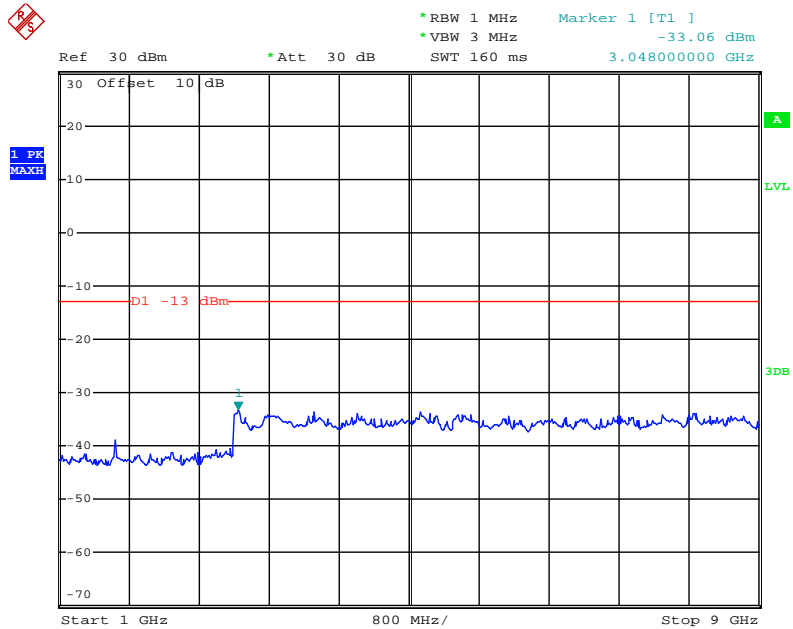

Date: 20.JUN.2019 18:04:39

30MHz – 9GHz (Channel 4183)

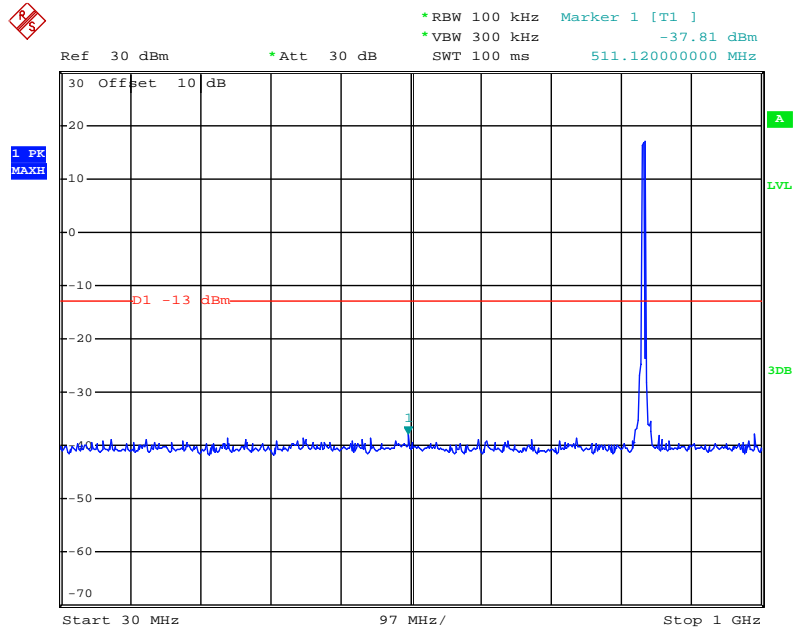

Date: 20.JUN.2019 18:00:53

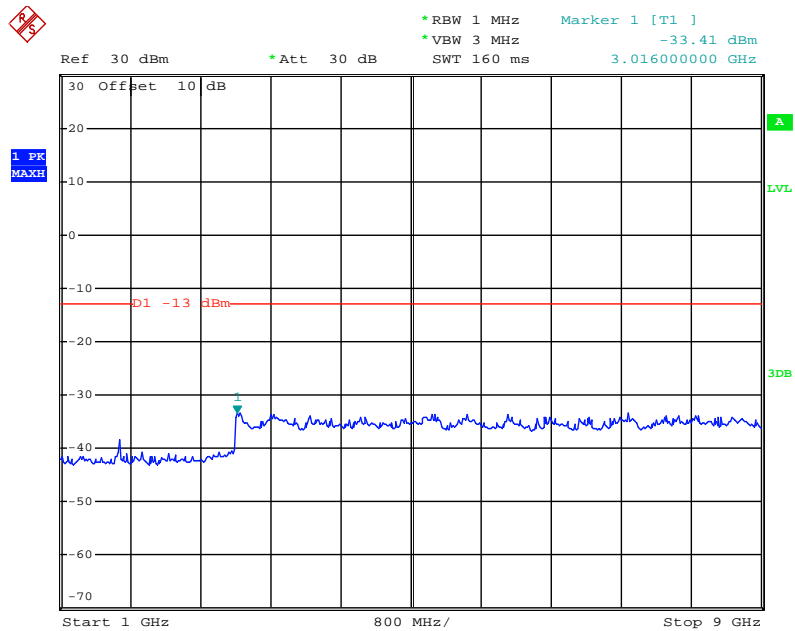

Date: 20.JUN.2019 18:04:12

30MHz – 9GHz (Channel 4233)

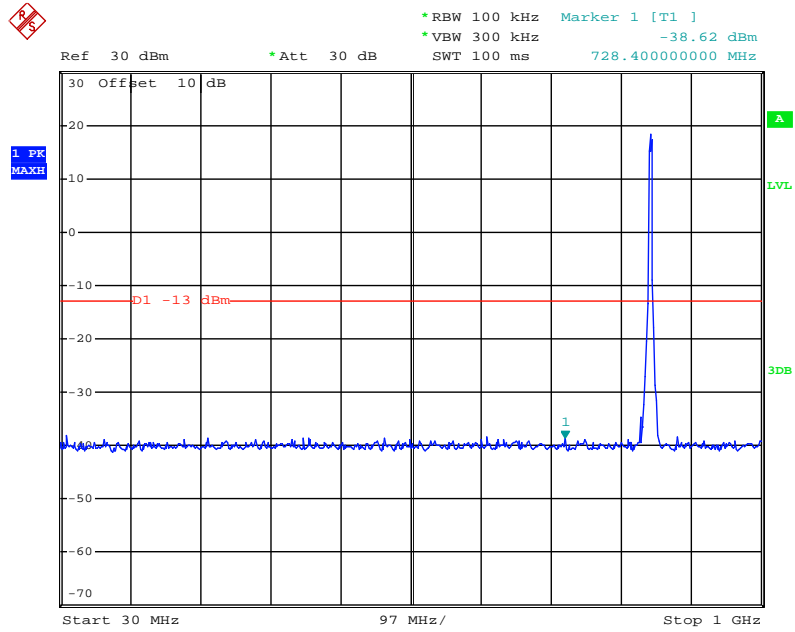

Date: 20.JUN.2019 18:01:50

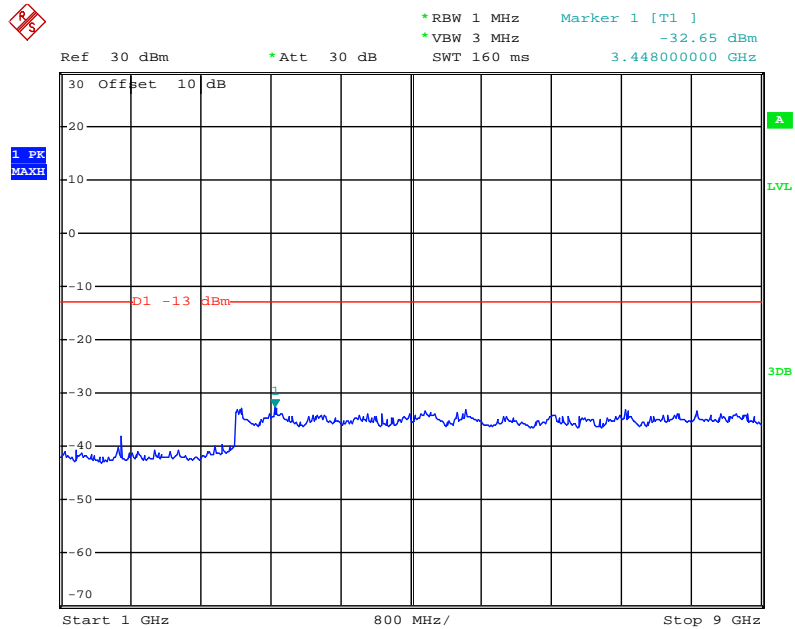

Date: 20.JUN.2019 18:03:23

UMTS FDD II

30MHz – 20GHz (Channel 9262)

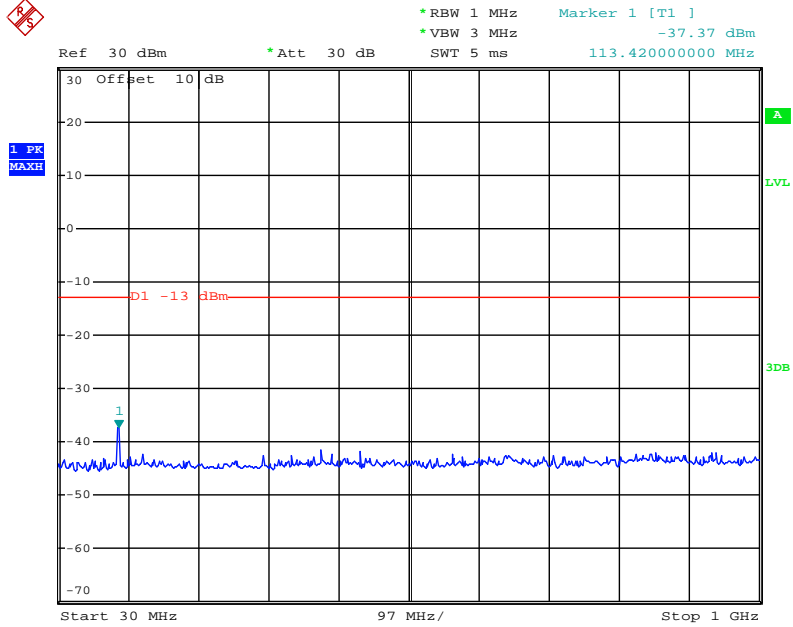

Date: 20.JUN.2019 17:57:02

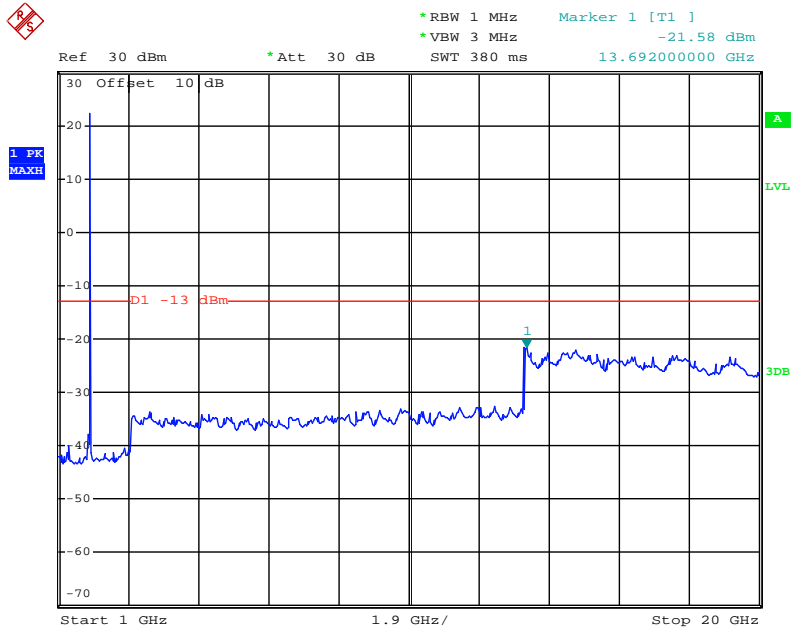

Date: 20.JUN.2019 17:56:12

30MHz – 20GHz (Channel 9400)

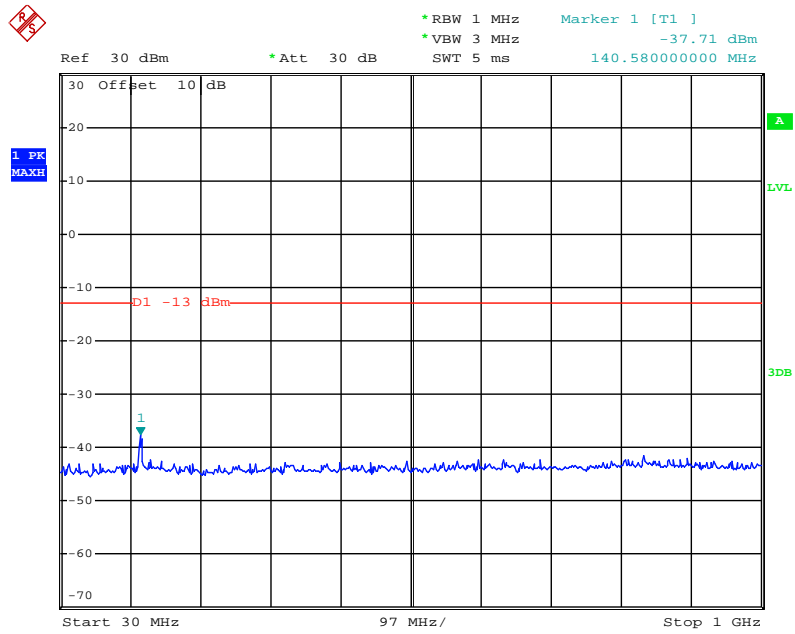

Date: 20.JUN.2019 17:57:43

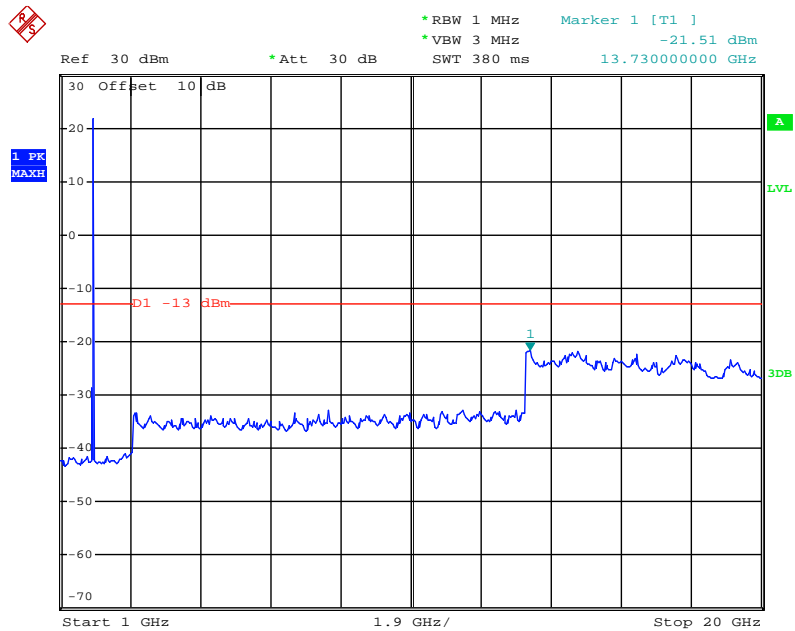

Date: 20.JUN.2019 17:55:42

30MHz – 20GHz (Channel 9538)

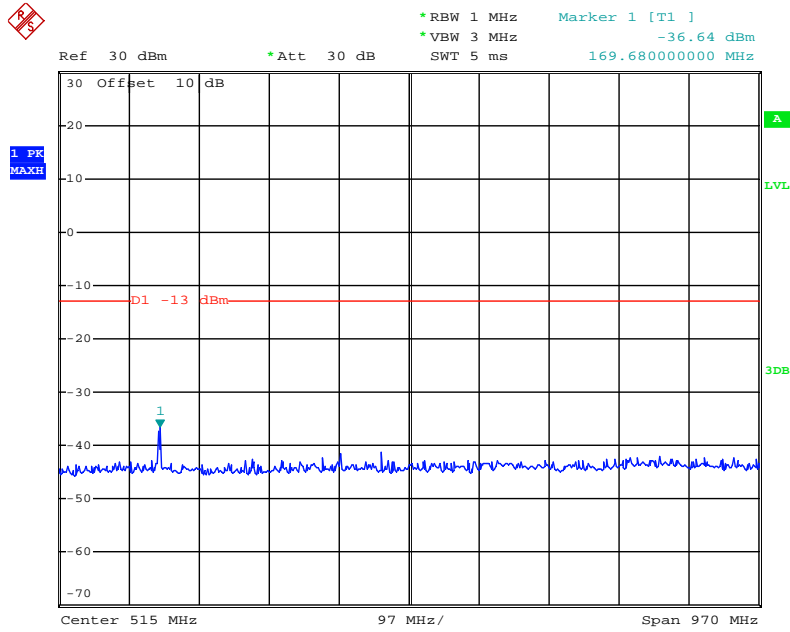

Date: 20.JUN.2019 17:58:09

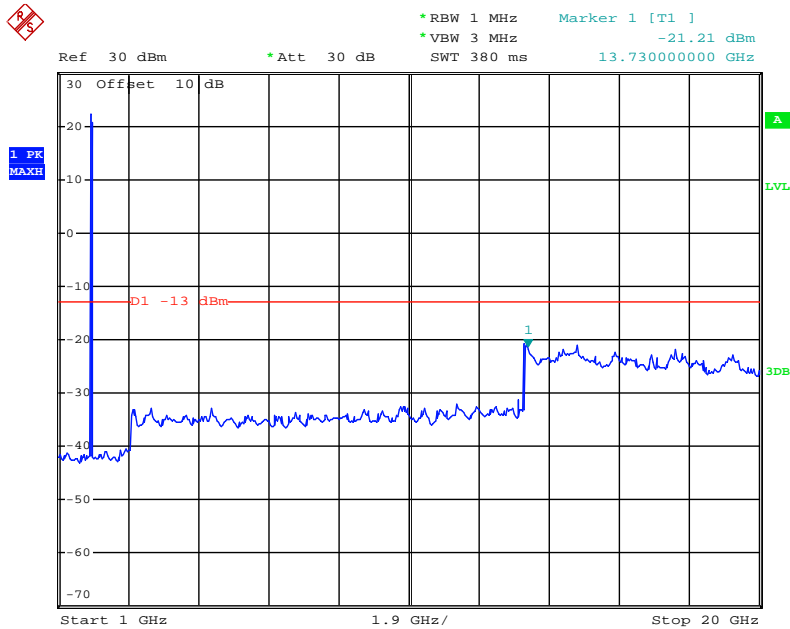

Date: 20.JUN.2019 17:55:07

8. BAND EDGE COMPLIANCE TEST

8.1. Block Diagram of Test Setup

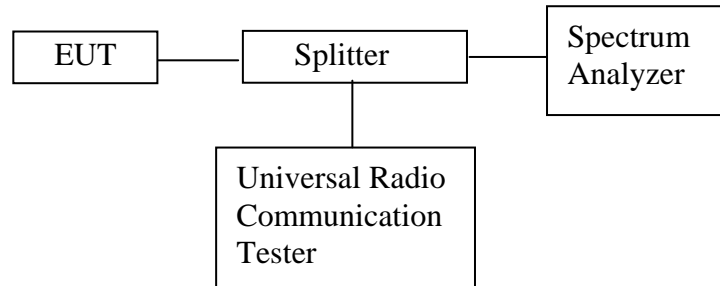

8.2. Applicable Standard

FCC §2.1051, §22.917, §24.238.

8.3. Operating Condition of EUT

8.3.1. Setup the EUT and simulator as shown as Section 8.1.

8.3.2. Turn on the power of all equipment.

8.3.3. Let the EUT work in TX modes measure it. The transmit frequency are 826.4-846.6MHz and 1852.4-1907.6MHz. We select 826.4MHz, 846.6MHz and 1852.4MHz, 1907.6MHz TX frequency to transmit.

8.4. Test Procedure

Conducted Band Edge:

8.4.1. Set the EUT to its maximum power at the required channel.

8.4.2. Measurements are to be performed with the EUT set to the low and high channel of each frequency band.

8.4.3. Set the RBW=100 kHz , VBW=300 kHz below 1GHz and above 1GHz.

8.4.4. Detector = RM.

8.4.5. Sweep time = auto.

8.4.6. Allow trace to fully stabilize.

8.5. Test Result

UMTS FDD V(Worse case)

Frequency (MHz)	Emission (dBm)	Limit (dBm)
823.34	-18.26	-13
849.18	-13.05	-13

UMTS FDD II(Worse case)

Frequency (MHz)	Emission (dBm)	Limit (dBm)
1849.72	-24.52	-13
1910.30	-21.68	-13

UMTS FDD V Band, Channel 4132

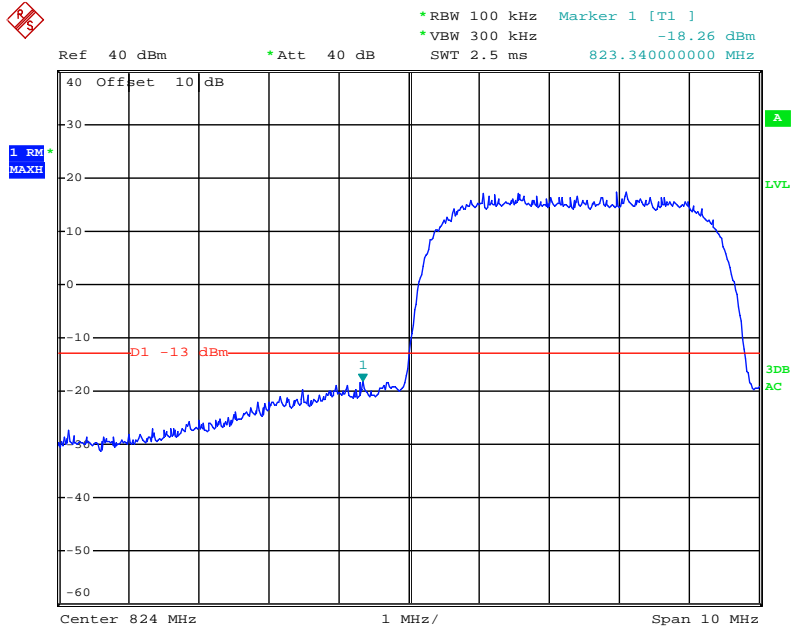

Date: 20.JUN.2019 17:35:07

UMTS FDD V Band, Channel 4233

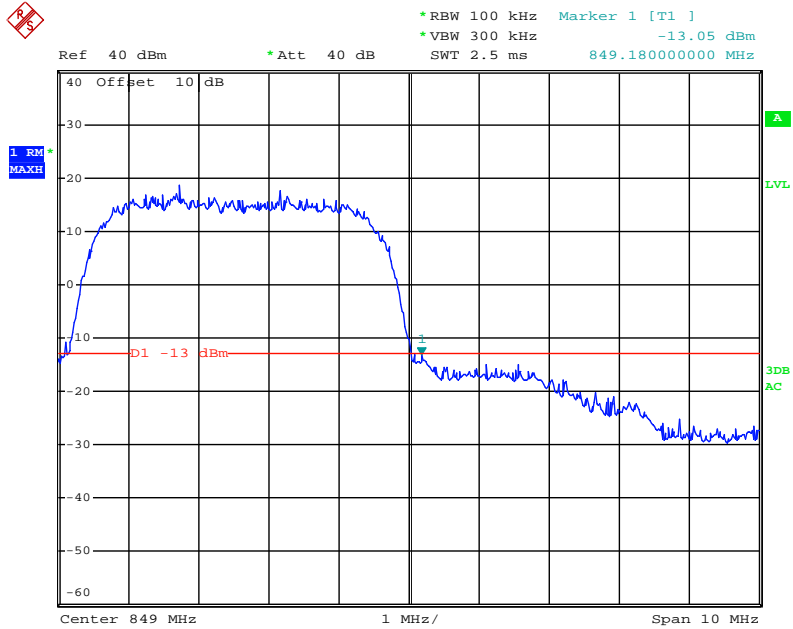

Date: 20.JUN.2019 17:34:13

UMTS FDD II Band, Channel 9262

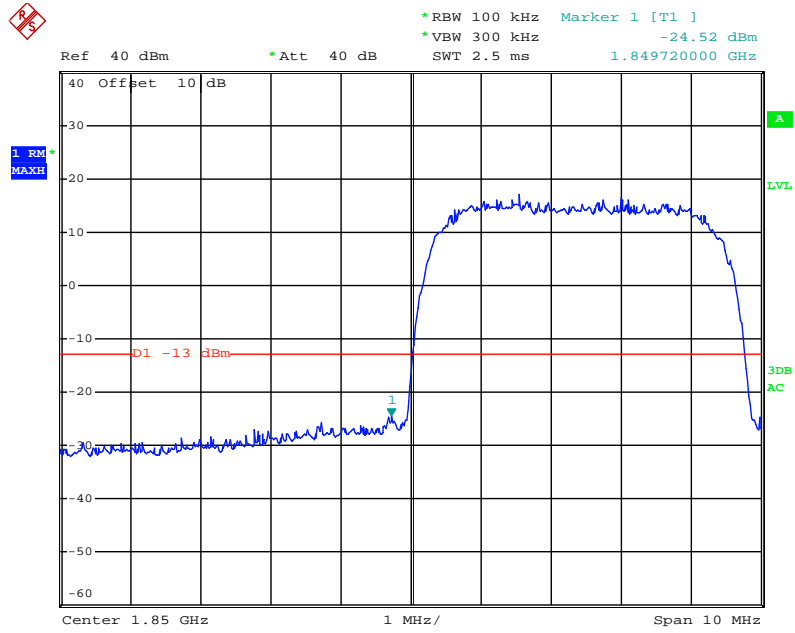

Date: 20.JUN.2019 17:31:56

UMTS FDD II Band, Channel 9538

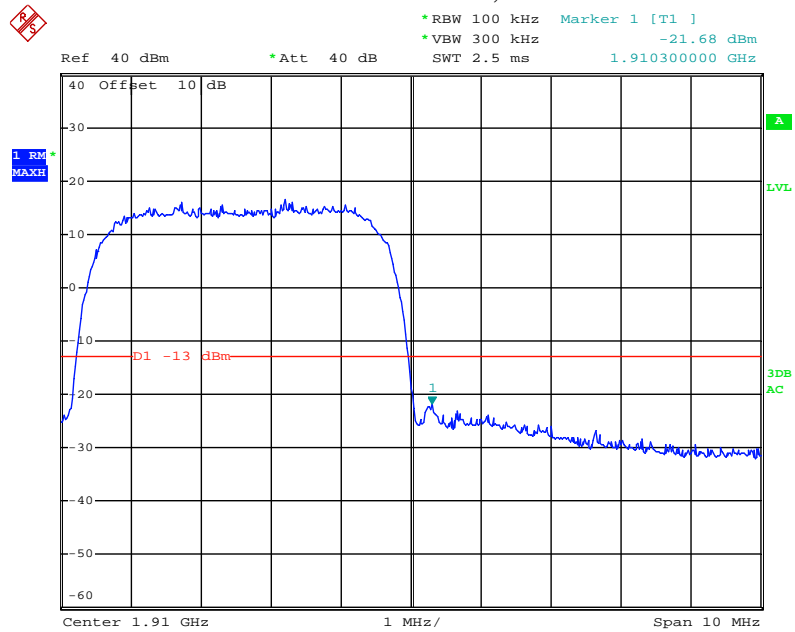

Date: 20.JUN.2019 17:30:58

9. RADIATED SPURIOUS EMISSION TEST

9.1. Block Diagram of Test Setup

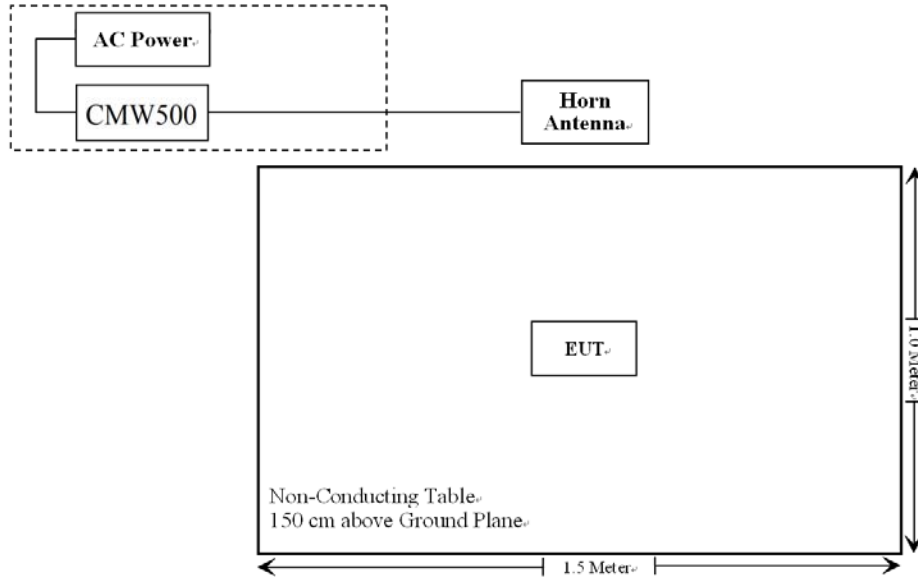

9.1.1. Semi-Anechoic Chamber Test Setup Diagram

(A) Radiated Emission Test Set-Up, Frequency below 30MHz

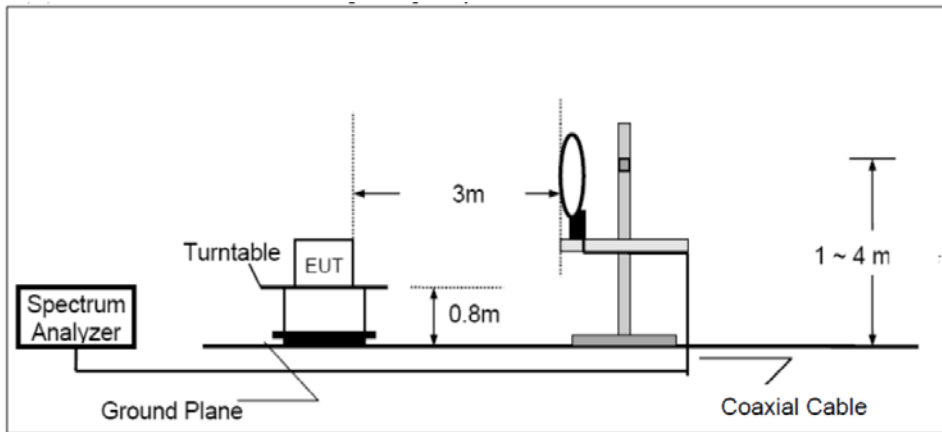

(B) Radiated Emission Test Set-Up, Frequency below 1GHz

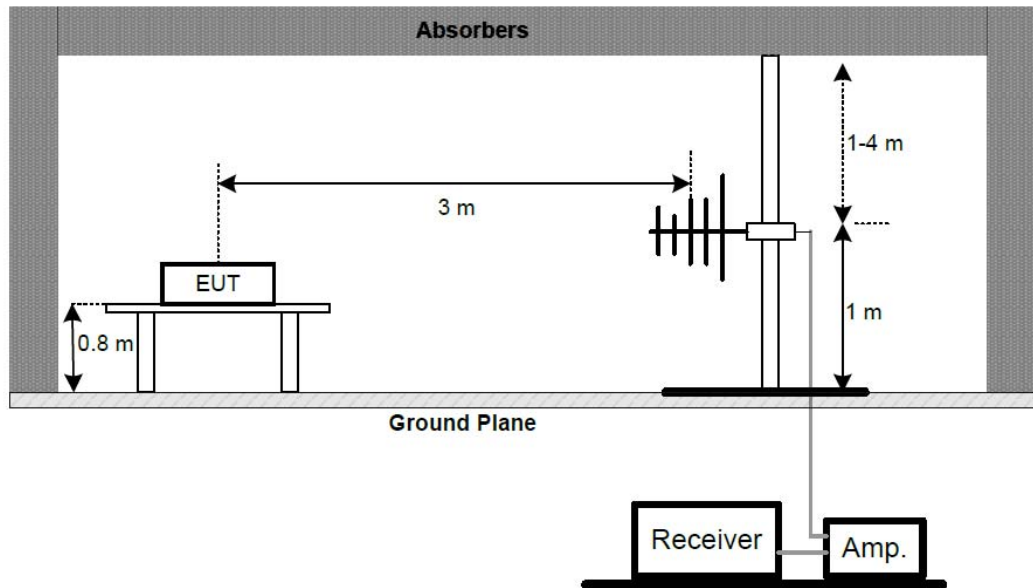

(C) Radiated Emission Test Set-Up, Frequency Above 1GHz

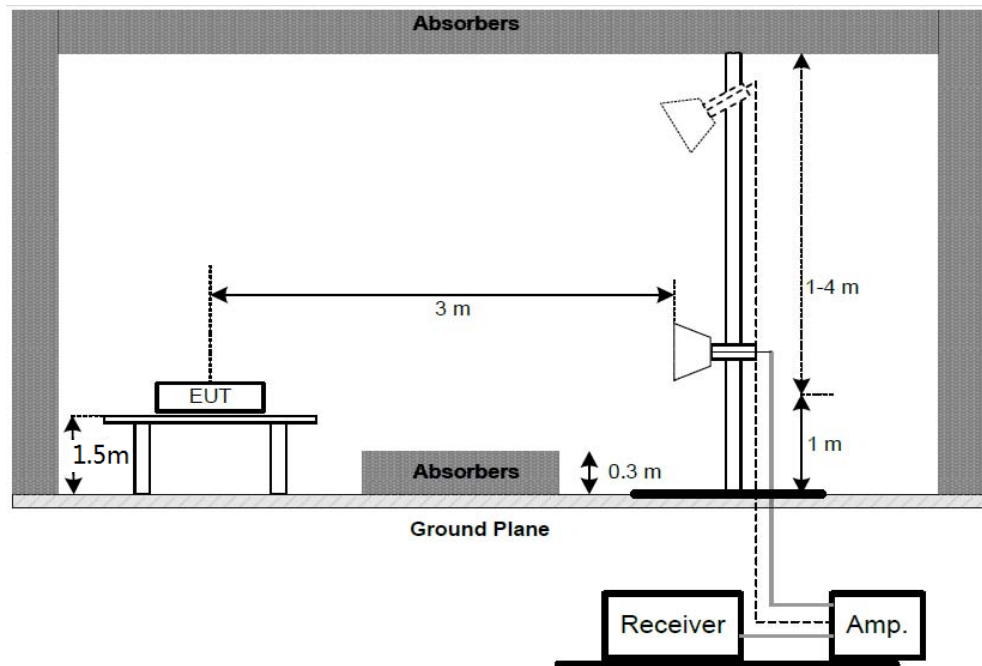

9.2. Applicable Standard

FCC §2.1051, §22.917(a), §24.238(a)

9.3.Restricted bands of operation

9.3.1.FCC Part 15.205 Restricted bands of operation

(a) Except as shown in paragraph (d) of this section, Only spurious emissions are permitted in any of the frequency bands listed below:

MHz	MHz	MHz	GHz
0.090-0.110	16.42-16.423	399.9-410	4.5-5.15
¹ 0.495-0.505	16.69475-16.69525	608-614	5.35-5.46
2.1735-2.1905	16.80425-16.80475	960-1240	7.25-7.75
4.125-4.128	25.5-25.67	1300-1427	8.025-8.5
4.17725-4.17775	37.5-38.25	1435-1626.5	9.0-9.2
4.20725-4.20775	73-74.6	1645.5-1646.5	9.3-9.5
6.215-6.218	74.8-75.2	1660-1710	10.6-12.7
6.26775-6.26825	108-121.94	1718.8-1722.2	13.25-13.4
6.31175-6.31225	123-138	2200-2300	14.47-14.5
8.291-8.294	149.9-150.05	2310-2390	15.35-16.2
8.362-8.366	156.52475-156.52525	2483.5-2500	17.7-21.4
8.37625-8.38675	156.7-156.9	2690-2900	22.01-23.12
8.41425-8.41475	162.0125-167.17	3260-3267	23.6-24.0
12.29-12.293	167.72-173.2	3332-3339	31.2-31.8
12.51975-12.52025	240-285	3345.8-3358	36.43-36.5
12.57675-12.57725	322-335.4	3600-4400	(²)
13.36-13.41			

¹Until February 1, 1999, this restricted band shall be 0.490-0.510

²Above 38.6

(b) Except as provided in paragraphs (d) and (e), the field strength of emission appearing within these frequency bands shall not exceed the limits shown in Section 15.209. At frequencies equal to or less than 1000MHz, Compliance with the limits in Section 15.209 shall be demonstrated using measurement instrumentation employing a CISPR quasi-peak detector. Above 1000MHz, compliance with the emission limits in Section 15.209 shall be demonstrated based on the average value of the measured emissions. The provisions in Section 15.35 apply to these measurements.

9.4.Configuration of EUT on Measurement

The equipment are installed on Radiated Emission Measurement to meet the commission requirements and operating regulations in a manner which tends to maximize its emission characteristics in normal application.

9.5. Operating Condition of EUT

9.5.1. Setup the EUT and simulator as shown as Section 9.1.

9.5.2. Turn on the power of all equipment.

9.5.3. Let the EUT work in TX modes measure it. The transmit frequency are 826.4-846.6MHz and 1852.4-1907.6MHz. We select 826.4MHz, 836.6MHz, 846.6MHz and 1852.4MHz, 1880.0MHz, 1907.6MHz TX frequency to transmit.

9.6. Test Procedure

The EUT and its simulators are placed on a turntable, which is 0.8 meter high above ground (Below 1GHz). The EUT and its simulators are placed on a turntable, which is 1.5 meter high above ground (Above 1GHz). The turntable can rotate 360 degrees to determine the position of the maximum emission level. EUT is set 3.0 meters away from the receiving antenna, which is mounted on an antenna tower. The antenna can be moved up and down between 1.0 meter and 4 meters to find out the maximum emission level. Broadband antenna (calibrated bilog antenna) is used as receiving antenna. Both horizontal and vertical polarizations of the antenna are set on measurement. In order to find the maximum emission levels, all of the interface cables must be manipulated according to TIA 603-D on radiated emission measurement. The EUT was tested in 3 orthogonal planes.

The bandwidth of test receiver is set at 9kHz in below 30MHz. and set at 120kHz in 30-1000MHz, and 1MHz in above 1000MHz.

The frequency range from 9kHz to 20GHz is checked.

The final measurement in band 9-90kHz, 110-490kHz and above 1000MHz is performed with Average detector. Except those frequency bands mention above, the final measurement for frequencies below 1000MHz is performed with Quasi Peak detector.

Spurious emissions in dB = $10 \lg(\text{TXpwr in Watts}/0.001)$ – the absolute level

Spurious attenuation limit in dB = $43 + 10 \text{Log}_{10}(\text{power out in Watts})$

9.7. The Field Strength of Radiation Emission Measurement Results

Note: 1. Emissions attenuated more than 20 dB below the permissible value are not reported.

2. The EUT is tested radiation emission at each test mode in three axes. The worst emissions are reported in all test mode and channels.

UMTS FDD V Band (WCDMA850)

Indicated		Table Angle Degree	Test Antenna		Substituted				Absolute Level (dBm)	Limit (dBm)	Margin (dB)
Frequency (MHz)	S.A. Reading (dBμV/m)		Height (m)	Polar (H/V)	Frequency (MHz)	Level (dBm)	Ant. Gain (dBi)	Cable Loss (dB)			
Low Channel(826.4MHz)											
1652.2	54.43	121	1.5	V	1652.2	-47.6	9.4	0.95	-39.21	-13	26.21
1652.2	45.70	237	1.6	H	1652.2	-57.8	9.4	0.95	-49.41	-13	36.41
3305.8	45.28	135	1.7	V	3305.8	-48.2	10.1	2.08	-40.24	-13	27.24
3305.8	41.73	217	1.8	H	3305.8	-52.7	10.1	2.08	-44.74	-13	31.74
36.43	55.82	120	1.1	V	36.43	-39.7	0	0.32	-40.08	-13	27.08
324.57	58.43	114	1.1	H	324.57	-36.5	0	0.53	-37.09	-13	24.09

UMTS FDD V Band (WCDMA850)

Indicated		Table Angle Degree	Test Antenna		Substituted				Absolute Level (dBm)	Limit (dBm)	Margin (dB)
Frequency (MHz)	S.A. Reading (dBμV/m)		Height (m)	Polar (H/V)	Frequency (MHz)	Level (dBm)	Ant. Gain (dBi)	Cable Loss (dB)			
Middle Channel (836.6MHz)											
1673.2	55	30	1.6	V	1673.2	-47.0	9.4	0.98	-38.64	-13	25.64
1673.2	46.27	268	1.5	H	1673.2	-57.2	9.4	0.98	-48.84	-13	35.84
3346.8	45.85	215	1.8	V	3346.8	-47.6	10.2	2.10	-39.56	-13	26.56
3346.8	42.3	121	1.9	H	3346.8	-52.1	10.2	2.10	-44.06	-13	31.06
36.43	56.39	225	1.1	V	36.43	-39.1	0	0.32	-39.48	-13	26.48
324.57	59	319	1.1	H	324.57	-35.9	0	0.53	-36.49	-13	23.49

UMTS FDD V Band (WCDMA850)

Indicated		Table Angle Degree	Test Antenna		Substituted				Absolute Level (dBm)	Limit (dBm)	Margin (dB)
Frequency (MHz)	S.A. Reading (dBμV/m)		Height (m)	Polar (H/V)	Frequency (MHz)	Level (dBm)	Ant. Gain (dBi)	Cable Loss (dB)			
High Channel(846.6MHz)											
1693.2	53.16	122	1.3	V	1693.2	-48.9	9.4	1.00	-40.56	-13	27.56
1693.2	44.53	238	1.4	H	1693.2	-59.0	9.4	1.00	-50.66	-13	37.86
3386.4	44.01	241	1.5	V	3386.4	-49.5	10.2	2.10	-41.46	-13	28.46
3386.4	40.46	67	1.6	H	3386.4	-54.0	10.2	2.10	-45.96	-13	32.96
36.43	54.55	249	1.0	V	36.43	-41.0	0	0.32	-41.38	-13	28.38
324.57	57.16	101	1.0	H	324.57	-37.8	0	0.53	-38.39	-13	25.39

UMTS FDD II Band (WCDMA1900)

Indicated		Table Angle Degree	Test Antenna		Substituted				Absolute Level (dBm)	Limit (dBm)	Margin (dB)
Frequency (MHz)	S.A. Reading (dBμV/m)		Height (m)	Polar (H/V)	Frequency (MHz)	Level (dBm)	Ant. Gain (dBi)	Cable Loss (dB)			
Low Channel(1852.4MHz)											
3704.8	51.92	179	1.6	V	3704.8	-44.59	10.3	2.58	-36.87	-13	23.87
3704.8	47.06	113	1.5	H	3704.8	-50.19	10.3	2.58	-42.47	-13	29.47
5557.2	39.39	77	1.6	V	5557.2	-51.79	11.6	3.93	-44.12	-13	31.12
5557.2	39.71	81	1.7	H	5557.2	-52.69	11.6	3.93	-45.02	-13	32.02
36.43	55.33	95	1.1	V	36.43	-40.19	0	0.32	-40.51	-13	27.51
330.57	57.42	113	1.1	H	324.57	-37.99	0	0.53	-38.52	-13	25.52

UMTS FDD II Band (WCDMA1900)

Indicated		Table Angle Degree	Test Antenna		Substituted				Absolute Level (dBm)	Limit (dBm)	Margin (dB)
Frequency (MHz)	S.A. Reading (dBμV/m)		Height (m)	Polar (H/V)	Frequency (MHz)	Level (dBm)	Ant. Gain (dBi)	Cable Loss (dB)			
Middle Channel(1880.0MHz)											
3760	51.35	170	1.8	V	3760	-45.16	10.3	2.59	-37.45	-13	24.45
3760	46.49	212	1.7	H	3760	-50.76	10.3	2.59	-43.05	-13	30.05
5640	38.82	197	1.4	V	5640	-52.36	11.7	3.94	-44.60	-13	31.60
5640	39.14	237	1.7	H	5640	-53.26	11.7	3.94	-45.50	-13	32.50
36.43	54.76	108	1.1	V	36.43	-40.76	0	0.32	-40.44	-13	27.44
330.57	56.85	218	1.2	H	324.57	-38.56	0	0.53	-39.09	-13	26.09

UMTS FDD II Band (WCDMA1900)

Indicated		Table Angle Degree	Test Antenna		Substituted				Absolute Level (dBm)	Limit (dBm)	Margin (dB)
Frequency (MHz)	S.A. Reading (dBμV/m)		Height (m)	Polar (H/V)	Frequency (MHz)	Level (dBm)	Ant. Gain (dBi)	Cable Loss (dB)			
High Channel(1907.6MHz)											
3815.2	50.08	272	2.1	V	3815.2	-46.43	10.4	2.60	-38.63	-13	25.63
3815.2	45.22	112	1.7	H	3815.2	-52.03	10.4	2.60	-44.23	-13	31.23
5722.8	37.55	307	1.4	V	5722.8	-53.63	11.8	3.95	-45.78	-13	32.78
5722.8	37.87	185	1.9	H	5722.8	-54.53	11.8	3.95	-46.68	-13	33.68
36.43	53.49	218	1.1	V	36.43	-42.03	0	0.32	-42.35	-13	29.35
330.57	55.58	235	1.1	H	324.57	-39.83	0	0.53	-40.36	-13	27.36

Note:

Absolute Level=SG Level- Cable loss + Antenna Gain

Margin=Limit- Absolute Level

10.FREQUENCY STABILITY

10.1.Block Diagram of Test Setup

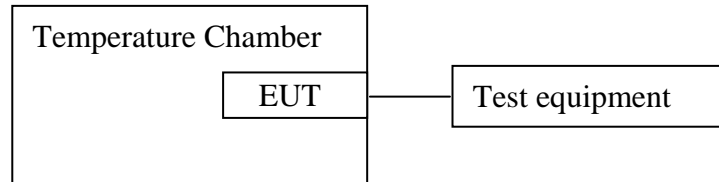

10.2.The Requirement For Section CFR47 § 2.1055 (a), § 2.1055 (d), §22.355, §24.235

According to §22.355, the carrier frequency of each transmitter in the Public Mobile Services must be maintained within the tolerances given in Table below:
Frequency Tolerance for Transmitters in the Public Mobile Services

Frequency Range (MHz)	Base, fixed (ppm)	Mobile ≤ 3 watts (ppm)	Mobile ≤ 3 watts (ppm)
25 to 50	20.0	20.0	50.0
50 to 450	5.0	5.0	50.0
450 to 512	2.5	5.0	5.0
821 to 896	1.5	2.5	2.5
928 to 929.	5.0	N/A	N/A
929 to 960.	1.5	N/A	N/A
2110 to 2220	10.0	N/A	N/A

According to

§24.235, the frequency stability shall be sufficient to ensure that the fundamental emissions stays within the authorized frequency block.

10.3.Operating Condition of EUT

10.3.1.Setup the EUT and simulator as shown as Section 10.1.

10.3.2.Turn on the power of all equipment.

10.3.3.Let the EUT work in Test modes measure it. The test frequency are 836.6MHz and 1880MHz.

10.4.Test Procedure

Frequency Stability vs. Temperature: The equipment under test was connected to an external DC power supply and the RF output was connected to communication test set

via feed-through attenuators. The EUT was placed inside the temperature chamber. The DC leads and RF output cable exited the chamber through an opening made for the purpose.

After the temperature stabilized for approximately 20 minutes, the frequency output was recorded from the communication test set.

Frequency Stability vs. Voltage: Vary primary supply voltage from 85 to 115 percent of the nominal value for other than hand carried battery equipment. The output frequency was recorded for each voltage.

10.5. Test Result

Pass.

UMTS FDD V Band Middle Channel, fo = 836.6 MHz

Middle Channel, fo = 836.6 MHz				
Temperature (OC)	Power Supplied (VDC)	Frequency Error (Hz)	Frequency Error (ppm)	Limit (ppm)
-30	24	13	0.0191	2.5
-20		21	0.0287	2.5
-10		27	0.0359	2.5
0		19	0.0263	2.5
10		25	0.0335	2.5
20		22	0.0299	2.5
30		31	0.0406	2.5
40		19	0.0263	2.5
50		10	0.0155	2.5
25		10.2	18	0.0251
	27.6	34	0.0442	2.5

UMTS FDD II Band Middle Channel, fo = 1880 MHz

Middle Channel, fo = 1880 MHz				
Temperature (OC)	Power Supplied (VDC)	Frequency Error (Hz)	Frequency Error (ppm)	Limit (ppm)
-30	24	24	0.0287	2.5
-20		42	0.0502	2.5
-10		36	0.0430	2.5
0		26	0.0311	2.5
10		43	0.0514	2.5
20		24	0.0287	2.5
30		45	0.0538	2.5
40		31	0.0370	2.5
50		39	0.0466	2.5
25		10.2	47	0.0562
	27.6	52	0.0622	2.5

11. PEAK TO AVERAGE RATIO

11.1. Block Diagram of Test Setup

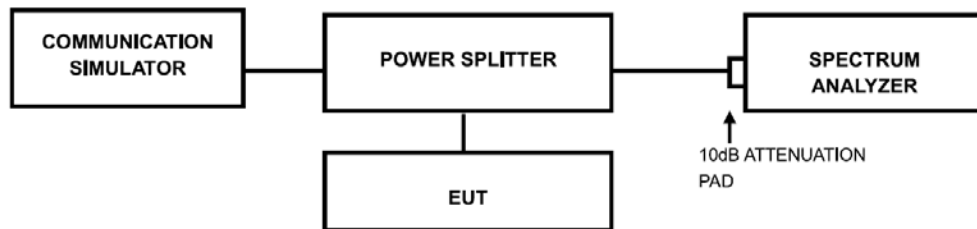

11.2. The LIMITS OF PEAK TO AVERAGE RATIO MEASUREMENT

In measuring transmissions in this band using an average power technique, the peak to-average ratio (PAR) of the transmission may not exceed 13dB

11.3. Operating Condition of EUT

11.3.1. Setup the EUT and simulator as shown as Section 11.1.

11.3.2. Turn on the power of all equipment.

11.3.3. Let the EUT work in Test modes then measure it. The test frequency are 836.4MHz and 1880MHz.

11.4. Test Procedure

11.4.1. Set resolution/measurement bandwidth \geq signal's occupied bandwidth;

11.4.2. Set EUT in maximum power output;

11.4.3. The signal analyzer was set to collect one million samples to generate the CCDF curve;

11.4.4. Record the maximum PAPR level associated with a probability pf 0.1%

11.5. Test Result

Pass.

Mode	CHANNEL	PEAK TO AVERAGE RATIO (dB)	Limit (dB)
Band II	9400	3.30	13
Band V	4182	3.34	13



Band II-9400



Band V-4182

12. ANTENNA REQUIREMENT

12.1. The Requirement

According to Section 15.203, an intentional radiator shall be designed to ensure that no antenna other than that furnished by the responsible party shall be used with the device.

12.2. Antenna Construction

The antenna use a unique coupling to the intentional radiator shall be considered sufficient to comply with the provisions of this section. The manufacturer may design the unit so that a broken antenna can be replaced by the user, but the use of a standard antenna jack or electrical connector is prohibited. The antenna jack of EUT correspond to the standard. The Antenna gain of EUT is 0dBi. Therefore, the equipment complies with the antenna requirement of Section 15.203.

Antenna

