



**中认信通**  
CHINA CERTIFICATION ICT CO., LTD (DONGGUAN)



## TEST REPORT

**Applicant: SHENZHEN COBAN ELECTRONICS CO., LTD**

Address: 5/F, Block 22, Wisdomland Business Park, Guankou 2nd Road, Nantou,  
Nanshan District, Shenzhen, Guangdong, China.518052

**FCC ID: 2ATUK-BN-108**

**Product Name: GPS TRACKER**

**Standard(s): 47 CFR Part 2  
47 CFR Part 22, Subpart H  
47 CFR Part 24, Subpart E  
ANSI C63.26-2015**

The above equipment has been tested and found compliant with the requirement of the relative standards by China Certification ICT Co., Ltd (Dongguan)

**Report Number: CR230846744-00**

**Date Of Issue: 2023/9/18**

**Reviewed By: Calvin Chen**

Title: RF Engineer

**Approved By: Sun Zhong**

Title: Manager

**Test Laboratory: China Certification ICT Co., Ltd (Dongguan)**

No. 113, Pingkang Road, Dalang Town, Dongguan,  
Guangdong, China  
Tel: +86-769-82016888

## Test Facility

The Test site used by China Certification ICT Co., Ltd (Dongguan) to collect test data is located on the No. 113, Pingkang Road, Dalang Town, Dongguan, Guangdong, China.

The lab has been recognized as the FCC accredited lab under the KDB 974614 D01 and is listed in the FCC Public Access Link (PAL) database, FCC Registration No. : 442868, the FCC Designation No. : CN1314.

The lab has been recognized by Innovation, Science and Economic Development Canada to test to Canadian radio equipment requirements, the CAB identifier: CN0123.

## Declarations

China Certification ICT Co., Ltd (Dongguan) is not responsible for the authenticity of any test data provided by the applicant. Data included from the applicant that may affect test results are marked with a triangle symbol “▲”. Customer model name, addresses, names, trademarks etc. are not considered data.

Unless otherwise stated the results shown in this test report refer only to the sample(s) tested.

This report cannot be reproduced except in full, without prior written approval of the Company.

This report is valid only with a valid digital signature. The digital signature may be available only under the Adobe software above version 7.0.

This report may contain data that are not covered by the accreditation scope and shall be marked with an asterisk “★”.

## CONTENTS

TEST FACILITY.....	2
DECLARATIONS.....	2
<b>DOCUMENT REVISION HISTORY.....</b>	<b>5</b>
<b>1. GENERAL INFORMATION.....</b>	<b>6</b>
<b>1.1 PRODUCT DESCRIPTION FOR EQUIPMENT UNDER TEST (EUT).....</b>	<b>6</b>
<b>1.2 DESCRIPTION OF TEST CONFIGURATION.....</b>	<b>7</b>
1.2.2 Support Equipment List and Details.....	7
1.2.3 Support Cable List and Details.....	8
1.2.4 Block Diagram of Test Setup.....	8
<b>1.3 MEASUREMENT UNCERTAINTY.....</b>	<b>9</b>
<b>2. SUMMARY OF TEST RESULTS.....</b>	<b>10</b>
<b>3. REQUIREMENTS AND TEST PROCEDURES.....</b>	<b>11</b>
3.1 Applicable Standard For Part 22 Subpart H:.....	11
3.1.1 RF Output Power.....	11
3.1.2 Spurious Emissions.....	11
3.1.3 Frequency stability.....	11
3.2 Applicable Standard For Part 24 Subpart E:.....	13
3.2.1 RF Output Power.....	13
3.2.2 Spurious Emissions.....	13
3.2.3 Frequency stability.....	13
3.4 Test Method:.....	14
3.4.1 RF Output Power.....	14
Test Setup Block:.....	14
3.4.2 Occupied Bandwidth.....	15
Test Setup Block:.....	16
3.4.3 Spurious emissions at antenna terminals.....	17
Test Setup Block:.....	17
3.4.4 Out of band emission.....	18
Test Setup Block:.....	18
3.4.5 Frequency stability.....	19
Test Setup Block:.....	19
3.4.6 Field strength of spurious radiation.....	20
<b>4. Test DATA AND RESULTS.....</b>	<b>22</b>
<b>4.1 ANTENNA PORT TEST DATA AND RESULTS FOR GSM 850 BAND:.....</b>	<b>22</b>
<b>4.2 ANTENNA PORT TEST DATA AND RESULTS FOR GSM 1900 BAND:.....</b>	<b>28</b>
<b>4.3 RADIATED SPURIOUS EMISSIONS.....</b>	<b>34</b>
<b>5. RF EXPOSURE EVALUATION.....</b>	<b>37</b>
<b>5.1 APPLICABLE STANDARD.....</b>	<b>37</b>

---

<b>5.2 CALCULATION FORMULA:</b> .....	<b>37</b>
<b>5.3 CALCULATED DATA:</b> .....	<b>37</b>
<b>6. EUT PHOTOGRAPHS</b> .....	<b>38</b>
<b>7. TEST SETUP PHOTOGRAPHS</b> .....	<b>39</b>

---

## DOCUMENT REVISION HISTORY

---

Revision Number	Report Number	Description of Revision	Date of Revision
1.0	CR230846744-00	Original Report	2023/9/18

## 1. GENERAL INFORMATION

### 1.1 Product Description for Equipment under Test (EUT)

#### General:

<b>EUT Name:</b>	GPS TRACKER
<b>Trade Name:</b>	BAANOOL
<b>EUT Model:</b>	108
<b>Multiple Model:</b>	108AB, 108A, 108B, GPS-108, GPS-108AB, GPS-108A, GPS-108B, BN-108, BN-108AB, BN-108A, BN-108B
<b>Operation Bands and modes:</b>	GSM/GPRS: 850/1900
<b>Modulation Type:</b>	GMSK
<b>Rated Input Voltage:</b>	DC 3.7V from battery or DC 12-24V from cut relay or DC 5V from USB port
<b>Serial Number:</b>	29S9-1
<b>EUT Received Date:</b>	2023/8/14
<b>EUT Received Status:</b>	Good
Note: The Multiple models are electrically identical with test model, please refer to the declaration letter for more detail, which was provided by manufacturer.	

#### Operation Voltage( $V_{DC}$ ) ▲:

Lowest:	3.3	Normal:	3.7	Highest:	4.35
---------	-----	---------	-----	----------	------

#### Antenna Information ▲:

Antenna Type	Operation Bands	Antenna Frequency Range (MHz)	Antenna Gain ( $G_T$ ) (dBi)	$L_c$ (dB)
FPC	GSM850	824-849	-0.04	0
	PCS1900	1850-1910	0.59	0
Note: There is no cable between the transmitter and antenna.				

#### Accessory Information:

Accessory Description	Manufacturer	Model
/	/	/

## 1.2 Description of Test Configuration

### 1.2.1 EUT Operation Condition:

<b>EUT Operation Mode:</b>	The system was configured for testing in each operation mode.
<b>Equipment Modifications:</b>	No
<b>EUT Exercise Software:</b>	No
<p>The maximum power was configured per 3GPP Standard for each operation modes as below setting:</p> <p><b>GSM/GPRS</b></p> <p>Function: Menu select &gt; GSM Mobile Station &gt; GSM 850/1900          Press Connection control to choose the different menus          Press RESET &gt; choose all the reset all settings          Connection Press Signal Off to turn off the signal and change settings          Network Support &gt; GSM + GPRS or GSM + EGSM          Main Service &gt; Packet Data          Service selection &gt; Test Mode A – Auto Slot Config. off          MS Signal Press Slot Config Bottom on the right twice to select and change the number of time slots and power setting              &gt; Slot configuration &gt; Uplink/Gamma              &gt; 33 dBm for GPRS 850              &gt; 30 dBm for GPRS 1900          BS Signal Enter the same channel number for TCH channel (test channel) and BCCH channel          Frequency Offset &gt; + 0 Hz          Mode &gt; BCCH and TCH</p> <p>BCCH Level &gt; -85 dBm (May need to adjust if link is not stable)          BCCH Channel &gt; choose desire test channel [Enter the same channel number for TCH channel (test channel) and BCCH channel]</p> <p>Channel Type &gt; Off          P0 &gt; 4 dB          Slot Config &gt; Unchanged (if already set under MS signal)          TCH &gt; choose desired test channel          Hopping &gt; Off          Main Timeslot &gt; 3          Network Coding Scheme &gt; CS4 (GPRS)</p> <p>Bit Stream &gt; 2E9-1 PSR Bit Stream          AF/RF Enter appropriate offsets for Ext. Att. Output and Ext. Att. Input          Connection Press Signal on to turn on the signal and change settings</p>	

### 1.2.2 Support Equipment List and Details

Manufacturer	Description	Model	Serial Number
R&S	Universal Radio Communication Tester	CMU200	110 825

**1.2.3 Support Cable List and Details**

Cable Description	Shielding Type	Ferrite Core	Length (m)	From Port	To
/	/	/	/	/	/

**1.2.4 Block Diagram of Test Setup**

Radiation Test:

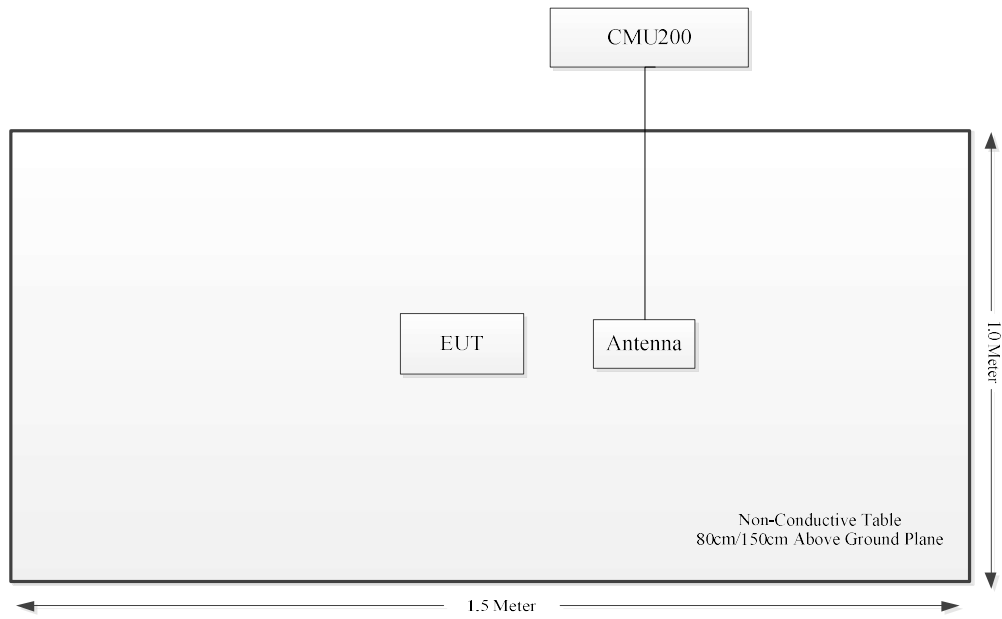



### 1.3 Measurement Uncertainty

Otherwise required by the applicant or Product Regulations, Decision Rule in this report did not consider the uncertainty. The extended uncertainty given in this report is obtained by combining the standard uncertainty times the coverage factor K with the 95% confidence interval.

Parameter	Measurement Uncertainty
Occupied Channel Bandwidth	±5 %
RF output power, conducted	±0.61dB
Power Spectral Density, conducted	±0.61 dB
Unwanted Emissions, radiated	30M~200MHz: 4.15 dB, 200M~1GHz: 5.61 dB, 1G~6GHz: 5.14 dB, 6G~18GHz: 5.93 dB, 18G~26.5G: 5.47 dB, 26.5G~40G: 5.63 dB
Unwanted Emissions, conducted	±1.26 dB
Temperature	±1 °C
Humidity	±5%
DC and low frequency voltages	±0.4%
Duty Cycle	1%
RF Frequency	±0.082×10 <sup>-6</sup>

## 2. SUMMARY OF TEST RESULTS

Rules	Description of Test	Result
FCC§2.1046; § 22.913; § 24.232	RF Output Power	Compliant
FCC§ 2.1047	Modulation Characteristics	Not Applicable
FCC§ 2.1049; § 22.905, §22.917; § 24.238	Occupied Bandwidth	Compliant
FCC§ 2.1051; § 22.917; § 24.238	Spurious Emissions at Antenna Terminal	Compliant
FCC§ 22.917; § 24.238	Out of band emission, Band Edge	Compliant
FCC§ 2.1055 § 22.355; § 24.235	Frequency stability vs. temperature Frequency stability vs. voltage	Compliant
FCC§ 2.1053 § 22.917; § 24.238	Field Strength of Spurious Radiation	Compliant
FCC §1.1310 §2.1091	RF Exposure Evaluation	Compliant

### 3. REQUIREMENTS AND TEST PROCEDURES

---

#### 3.1 Applicable Standard For Part 22 Subpart H:

##### 3.1.1 RF Output Power

FCC §22.913

(a)(5) The ERP of mobile transmitters and auxiliary test transmitters must not exceed 7watts.

(d) *Power measurement.* Measurement of the ERP of Cellular base transmitters and repeaters must be made using an average power measurement technique. The peak-toaverage ratio (PAR) of the transmission must not exceed 13 dB. Power measurements for base transmitters and repeaters must be made in accordance with either of the following:

- (1) A Commission-approved average power technique (*see* FCC Laboratory's Knowledge Database); or
- (2) For purposes of this section, peak transmit power must be measured over an interval of continuous transmission using instrumentation calibrated in terms of an rmsequivalent voltage. The measurement results shall be properly adjusted for any instrument limitations, such as detector response times, limited resolution bandwidth capability when compared to the emission bandwidth, sensitivity, *etc.*, so as to obtain a true peak measurement for the emission in question over the full bandwidth of the channel.

##### 3.1.2 Spurious Emissions

FCC §22.917

(a) Out of band emissions. The power of any emission outside of the authorized operating frequency ranges must be attenuated below the transmitting power (P) by a factor of at least  $43 + 10 \log(P)$  dB.

(b) Measurement procedure. Compliance with these rules is based on the use of measurement instrumentation employing a reference bandwidth as follows:

- (1) In the spectrum below 1 GHz, instrumentation should employ a reference bandwidth of 100 kHz or greater. In the 1 MHz bands immediately outside and adjacent to the frequency block, a resolution bandwidth of at least one percent of the emission bandwidth of the fundamental emission of the transmitter may be employed. A narrower resolution bandwidth is permitted in all cases to improve measurement accuracy, provided that the measured power is integrated over the full required reference bandwidth (i.e., 100 kHz or 1 percent of emission bandwidth, as specified). The emission bandwidth is defined as the width of the signal between two points, one below the carrier center frequency and one above the carrier center frequency, outside of which all emissions are attenuated at least 26 dB below the transmitter power.
- (2) In the spectrum above 1 GHz, instrumentation should employ a reference bandwidth of 1 MHz

##### 3.1.3 Frequency stability

FCC §22.355

Except as otherwise provided in this part, the carrier frequency of each transmitter in the Public Mobile Services must be maintained within the tolerances given in Table C-1 of this section.

Table C-1 - Frequency Tolerance for Transmitters in the Public Mobile Services

<b>Frequency range (MHz)</b>	<b>Base, fixed (ppm)</b>	<b>Mobile &gt;3 watts (ppm)</b>	<b>Mobile <math>\leq</math>3 watts (ppm)</b>
25 to 50	20	20	50
50 to 450	5	5	50
450 to 512	2.5	5	5
821 to 896	1.5	<b>2.5</b>	<b>2.5</b>
928 to 929	5	n/a	n/a
929 to 960	1.5	n/a	n/a
2110 to 2220	10	n/a	n/a

### **3.2 Applicable Standard For Part 24 Subpart E:**

#### **3.2.1 RF Output Power**

FCC §24.232

(c) Mobile and portable stations are limited to 2 watts EIRP and the equipment must employ a means for limiting power to the minimum necessary for successful communications.

(d) Power measurements for transmissions by stations authorized under this section may be made either in accordance with a Commission-approved average power technique or in compliance with paragraph (e) of this section. In both instances, equipment employed must be authorized in accordance with the provisions of § 24.51. In measuring transmissions in this band using an average power technique, the peak-to-average ratio (PAR) of the transmission may not exceed 13 dB.

#### **3.2.2 Spurious Emissions**

FCC §24.238

The rules in this section govern the spectral characteristics of emissions in the Broadband Personal Communications Service.

(a) Out of band emissions. The power of any emission outside of the authorized operating frequency ranges must be attenuated below the transmitting power (P) by a factor of at least  $43 + 10 \log(P)$  dB.

(b) Measurement procedure. Compliance with these rules is based on the use of measurement instrumentation employing a resolution bandwidth of 1 MHz or greater. However, in the 1 MHz bands immediately outside and adjacent to the frequency block a resolution bandwidth of at least one percent of the emission bandwidth of the fundamental emission of the transmitter may be employed. A narrower resolution bandwidth is permitted in all cases to improve measurement accuracy provided the measured power is integrated over the full required measurement bandwidth (i.e. 1 MHz or 1 percent of emission bandwidth, as specified). The emission bandwidth is defined as the width of the signal between two points, one below the carrier center frequency and one above the carrier center frequency, outside of which all emissions are attenuated at least 26 dB below the transmitter power.

(c) Alternative out of band emission limit. Licensees in this service may establish an alternative out of band emission limit to be used at specified band edge(s) in specified geographical areas, in lieu of that set forth in this section, pursuant to a private contractual arrangement of all affected licensees and applicants. In this event, each party to such contract shall maintain a copy of the contract in their station files and disclose it to prospective assignees or transferees and, upon request, to the FCC.

(d) Interference caused by out of band emissions. If any emission from a transmitter operating in this service results in interference to users of another radio service, the FCC may require a greater attenuation of that emission than specified in this section.

#### **3.2.3 Frequency stability**

FCC §24.235

The frequency stability shall be sufficient to ensure that the fundamental emission stays within the authorized frequency block.

### 3.4 Test Method:

#### 3.4.1 RF Output Power

According to CFR Part 2.1046, ANSI C63.26-2015 Section 5.2.5.5:

The relevant equation for determining the ERP or EIRP from the conducted RF output power measured using the guidance provided above is:

$$\text{ERP or EIRP} = P_{\text{Meas}} + G_T - L_C$$

where:

ERP or EIRP = effective radiated power or equivalent isotropically radiated power, respectively  
(expressed in the same units as  $P_{\text{Meas}}$ , typically dBW or dBm);

$P_{\text{Meas}}$  = measured transmitter output power or PSD, in dBm or dBW;

$G_T$  = gain of the transmitting antenna, in dBd (ERP) or dBi (EIRP);

$L_C$  = signal attenuation in the connecting cable between the transmitter and antenna, in dB.

#### Test Setup Block:

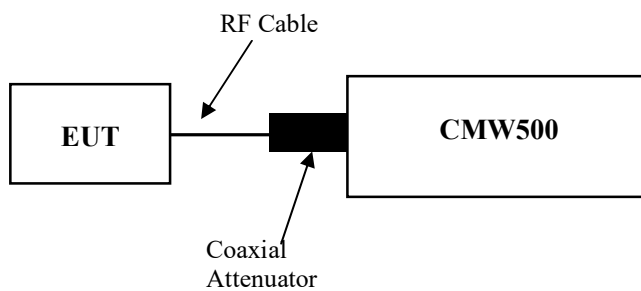

Note: The Insertion loss of the RF cable and coaxial Attenuator was offset into the Reading of CMW500.

### 3.4.2 Occupied Bandwidth

#### 26dB OBW:

According to CFR Part 2.1049, ANSI C63.26-2015 Section 5.4.3

The OBW is measured as the width of the spectral envelope of the modulated signal, at an amplitude level reduced from a reference value by a specified ratio (or in decibels, a specified number of dB down from the reference value). The typical ratio for transmitters is  $-26$  dB, corresponding to the 26 dB BW; however, other ratios can be specified. In this subclause, the ratio is designated by “ $-X$  dB.”

NOTE—This parameter, when expressed in relative terms, is often referred to in regulations as the EBW.

The reference level is either the amplitude of the unmodulated carrier, or the highest amplitude of the spectral envelope of the modulated signal, as stated by the applicable requirement. Some requirements can specify a particular maximum or minimum value for the “ $-X$  dB” bandwidth; other requirements can specify that the “ $-X$  dB” bandwidth be entirely contained within the authorized or designated frequency band.

- a) The spectrum analyzer center frequency is set to the nominal EUT channel center frequency. The span range for the spectrum analyzer shall be wide enough to see sufficient roll off of the signal to make the measurement.
- b) The nominal RBW shall be in the range of 1% to 5% of the anticipated OBW, and the VBW shall be set  $\geq 3 \times$  RBW.
- c) Set the reference level of the instrument as required to prevent the signal amplitude from exceeding the maximum spectrum analyzer input mixer level for linear operation. See guidance provided in 4.2.3.

NOTE—Step a), step b), and step c) may require iteration to adjust within the specified tolerances.

- d) The dynamic range of the spectrum analyzer at the selected RBW shall be more than 10 dB below the target “ $-X$  dB” requirement, i.e., if the requirement calls for measuring the  $-26$  dB OBW, the spectrum analyzer noise floor at the selected RBW shall be at least 36 dB below the reference level.
- e) Set spectrum analyzer detection mode to peak, and the trace mode to max hold.
- f) Determine the reference value by either of the following:
  - 1) Set the EUT to transmit a modulated signal. Allow the trace to stabilize. Set the spectrum analyzer marker to the highest level of the displayed trace (this is the reference value).
  - 2) Set the EUT to transmit an unmodulated carrier. Set the spectrum analyzer marker to the level of the carrier.
- g) Determine the “ $-X$  dB amplitude” as equal to (Reference Value  $- X$ ). Alternatively, this calculation can be performed on the spectrum analyzer using the delta-marker measurement function.
- h) If the reference value was determined using an unmodulated carrier, turn the EUT modulation on, then either clear the existing trace or start a new trace on the spectrum analyzer and allow the new trace to stabilize. Otherwise the trace from step f) shall be used for step i).
- i) Place two markers, one at the lowest and the other at the highest frequency of the envelope of the spectral display such that each marker is at or slightly below the “ $-X$  dB amplitude” determined in step f). If a marker is below this “ $-X$  dB amplitude” value it should be as close as possible to this value. The OBW is the positive frequency difference between the two markers.

**99% OBW:**

According to CFR Part 2.1049, ANSI C63.26-2015 Section 5.4.4

The OBW is the frequency bandwidth such that, below its lower and above its upper frequency limits, the mean powers are each equal to 0.5% of the total mean power of the given emission.

The following procedure shall be used for measuring (99%) power bandwidth:

- a) The spectrum analyzer center frequency is set to the nominal EUT channel center frequency. The frequency span for the spectrum analyzer shall be set wide enough to capture all modulation products including the emission skirts (typically a span of  $1.5 \times \text{OBW}$  is sufficient).
- b) The nominal IF filter 3 dB bandwidth (RBW) shall be in the range of 1% to 5% of the anticipated OBW, and the VBW shall be set  $\geq 3 \times \text{RBW}$ .
- c) Set the reference level of the instrument as required to prevent the signal amplitude from exceeding the maximum spectrum analyzer input mixer level for linear operation. See guidance provided in 4.2.3. NOTE—Step a), step b), and step c) may require iteration to adjust within the specified tolerances.
- d) Set the detection mode to peak, and the trace mode to max-hold.
- e) If the instrument does not have a 99% OBW function, recover the trace data points and sum directly in linear power terms. Place the recovered amplitude data points, beginning at the lowest frequency, in a running sum until 0.5% of the total is reached. Record that frequency as the lower OBW frequency. Repeat the process until 99.5% of the total is reached and record that frequency as the upper OBW frequency. The 99% power OBW can be determined by computing the difference these two frequencies.
- f) The OBW shall be reported and plot(s) of the measuring instrument display shall be provided with the test report. The frequency and amplitude axis and scale shall be clearly labeled. Tabular data can be reported in addition to the plot(s).

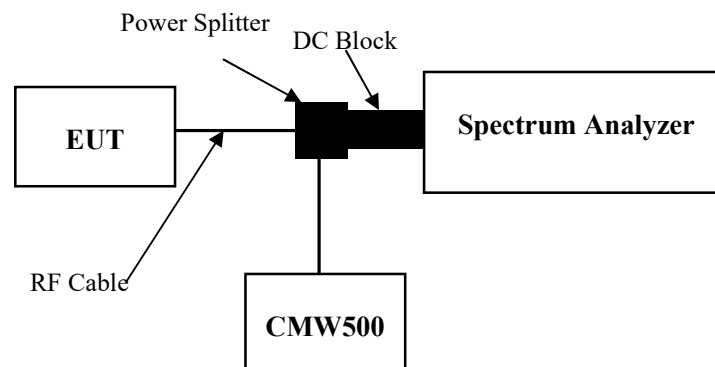
**Test Setup Block:**



### 3.4.3 Spurious emissions at antenna terminals

According to ANSI C63.26-2015 Section 5.7.4:

the applicable rule part specifies the reference bandwidth for measuring unwanted emission levels (typically, 100 kHz if the authorized frequency band/block is at or below 1 GHz and 1 MHz if the authorized frequency band/block is above 1 GHz),<sup>8</sup> effectively depicting the unwanted emission limit in terms of a power spectral density. In those cases where no reference bandwidth is explicitly specified, the values in the preceding sentence should be used.

#### Test Setup Block:

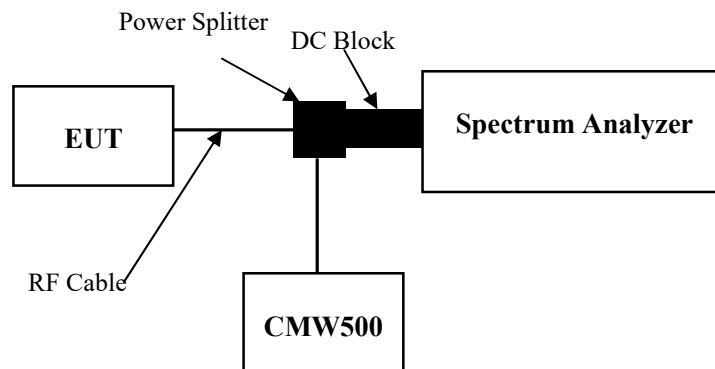

### 3.4.4 Out of band emission

According to ANSI C63.26-2015 Section 5.7.3:

Typically, a measurement (resolution) bandwidth smaller than the reference bandwidth is allowed for measurements within a specified frequency range at the edge of the authorized frequency block/band (e.g., within the first Y MHz outside of the authorized frequency band/block, where the value of Y is specified in the relevant rule part). Some FCC out-of-band emission rules permit the use of a narrower RBW (typically limited to a minimum RBW of 1 % of the OBW) for measuring the out-of-band emissions without a requirement to integrate the result over the full reference bandwidth. Beyond the specified frequency range in which this relaxation of the uniform reference bandwidth is permitted, it typically is also acceptable to use a narrower RBW (again limited to a minimum of 1 % of OBW) to increase accuracy, but the measurement result must subsequently be integrated over the full reference bandwidth.

#### Test Setup Block:

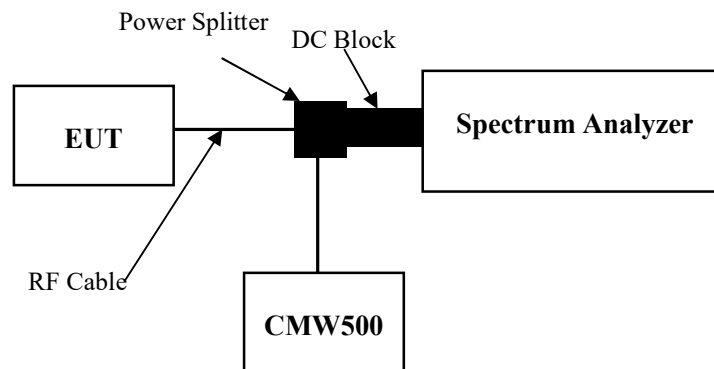

### 3.4.5 Frequency stability

According to ANSI C63.26-2015 Section 5.6:

Frequency stability is a measure of the frequency drift due to temperature and supply voltage variations, with reference to the frequency measured at +20 °C and rated supply voltage.

The operating carrier frequency shall be set up in accordance with the manufacturer's published operation and instruction manual prior to the commencement of these tests. No adjustment of any frequency determining circuit element shall be made subsequent to this initial set-up. Frequency stability is tested:

- a) At 10 °C intervals of temperatures between –30 °C and +50 °C at the manufacturer's rated supply voltage, and
- b) At +20 °C temperature and ±15% supply voltage variations. If a product is specified to operate over a range of input voltage then the –15% variation is applied to the lowermost voltage and the +15% is applied to the uppermost voltage.

During the test all necessary settings, adjustments and control of the EUT have to be performed without disturbing the test environment, i.e., without opening the environmental chamber. The frequency stabilities can be maintained to a lesser temperature range provided that the transmitter is automatically inhibited from operating outside the lesser temperature range. For handheld equipment that is only capable of operating from internal batteries and the supply voltage cannot be varied, the frequency stability tests shall be performed at the nominal battery voltage and the battery end point voltage specified by the manufacturer. An external supply voltage can be used and set at the internal battery nominal voltage, and again at the battery operating end point voltage which shall be specified by the equipment manufacturer.

If an unmodulated carrier is not available, the mean frequency of a modulated carrier can be obtained by using a frequency counter with gating time set to an appropriately large multiple of bit periods (gating time depending on the required accuracy). Full details on the choice of values shall be included in the test report.

#### Test Setup Block:

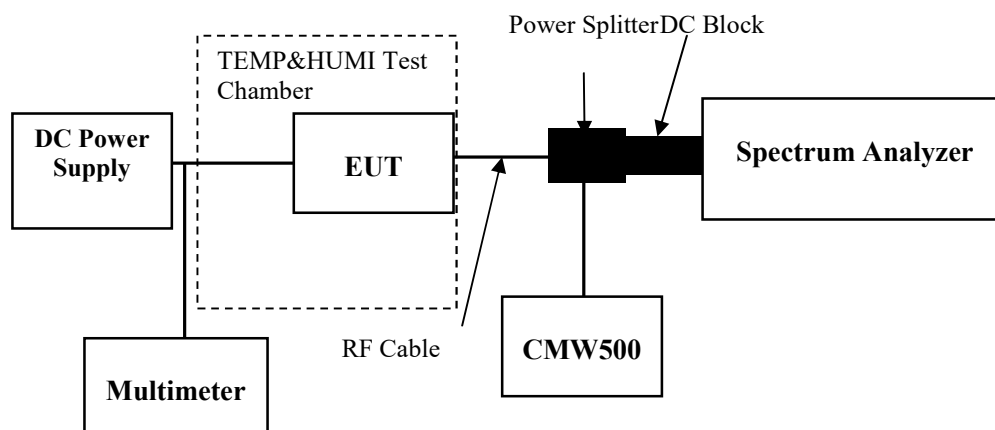

### 3.4.6 Field strength of spurious radiation

According to ANSI C63.26-2015 Section 5.5.3:

**Test setup:**

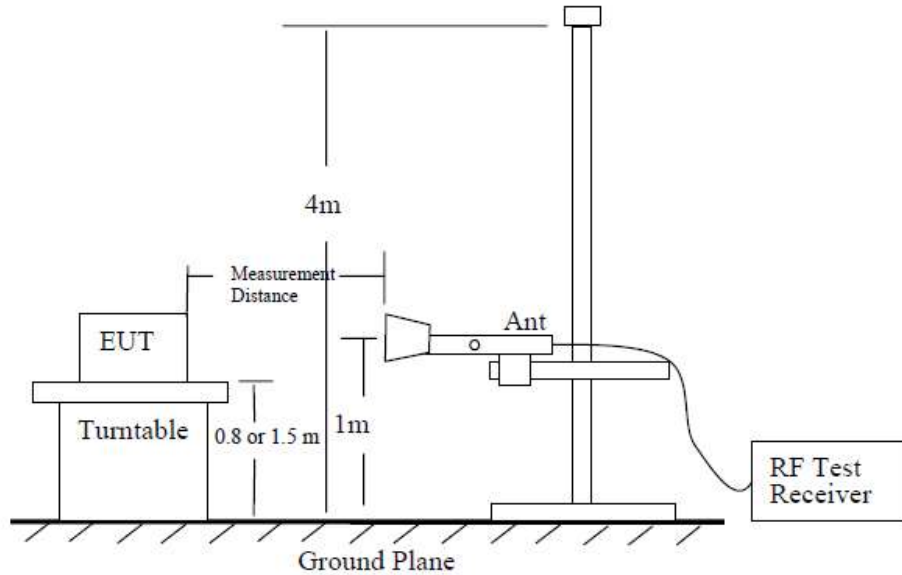

**Figure 6—Test site-up for radiated ERP and/or EIRP measurements**

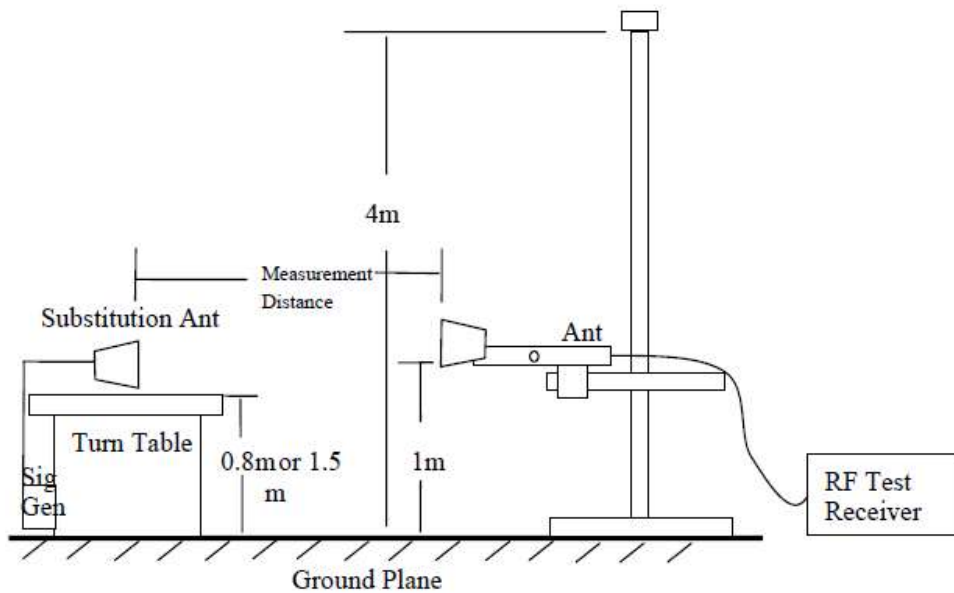

**Figure 7—Substitution method set-up for radiated emission**

**Test Procedure:**

- a) Place the EUT in the center of the turntable. The EUT shall be configured to transmit into the standard non-radiating load (for measuring radiated spurious emissions), connected with cables of minimal length unless specified otherwise. If the EUT uses an adjustable antenna, the antenna shall be positioned to the length that produces the worst case emission at the fundamental operating frequency.
- b) Each emission under consideration shall be evaluated:
  - 1) Raise and lower the measurement antenna in accordance 5.5.2, as necessary to enable detection of the maximum emission amplitude relative to measurement antenna height.
  - 2) Rotate the EUT through 360° to determine the maximum emission level relative to the axial position.
  - 3) Return the turntable to the azimuth where the highest emission amplitude level was observed.
  - 4) Vary the measurement antenna height again through 1 m to 4 m again to find the height associated with the maximum emission amplitude.
  - 5) Record the measured emission amplitude level and frequency using the appropriate RBW.
- c) Repeat step b) for each emission frequency with the measurement antenna oriented in both the horizontal and vertical polarizations to determine the orientation that gives the maximum emissions amplitude.
- d) Set-up the substitution measurement with the reference point of the substitution antenna located as near as possible to where the center of the EUT radiating element was located during the initial EUT measurement.
- e) Maintain the previous measurement instrument settings and test set-up, with the exception that the EUT is removed and replaced by the substitution antenna.
- f) Connect a signal generator to the substitution antenna; locate the signal generator so as to minimize any potential influences on the measurement results. Set the signal generator to the frequency where emissions are detected, and set an output power level such that the radiated signal can be detected by the measurement instrument, with sufficient dynamic range relative to the noise floor.
- g) For each emission that was detected and measured in the initial test [i.e., in step b) and step c)]:
  - 1) Vary the measurement antenna height between 1 m to 4 m to maximize the received (measured) signal amplitude.
  - 2) Adjust the signal generator output power level until the amplitude detected by the measurement instrument equals the amplitude level of the emission previously measured directly in step b) and step c).
  - 3) Record the output power level of the signal generator when equivalence is achieved in step 2).
- h) Repeat step e) through step g) with the measurement antenna oriented in the opposite polarization.
- i) Calculate the emission power in dBm referenced to a half-wave dipole using the following equation:
$$P_e = P_s(\text{dBm}) - \text{cable loss (dB)} + \text{antenna gain (dBd)}$$
where
  - $P_e$  = equivalent emission power in dBm
  - $P_s$  = source (signal generator) power in dBmNOTE—dBd refers to the measured antenna gain in decibels relative to a half-wave dipole.
- j) Correct the antenna gain of the substitution antenna if necessary to reference the emission power to a half-wave dipole. When using measurement antennas with the gain specified in dBi, the equivalent dipole-referenced gain can be determined from:  $\text{gain (dBd)} = \text{gain (dBi)} - 2.15 \text{ dB}$ . If necessary, the antenna gain can be calculated from calibrated antenna factor information
- k) Provide the complete measurement results as a part of the test report.

## 4. Test DATA AND RESULTS

### 4.1 Antenna Port Test Data and Results for GSM 850 band:

Serial Number:	29S9-1	Test Date:	2023/8/28
Test Site:	RF	Test Mode:	Transmitting
Tester:	Panda Sun	Test Result:	Pass

#### Environmental Conditions:

Temperature: (°C)	25.6	Relative Humidity: (%)	56	ATM Pressure: (kPa)	99.7
----------------------	------	------------------------------	----	------------------------	------

#### Test Equipment List and Details:

Manufacturer	Description	Model	Serial Number	Calibration Date	Calibration Due Date
R&S	Spectrum Analyzer	FSU26	100147	2023/3/31	2024/3/30
zhuoxiang	Coaxial Cable	SMA-178	211001	Each time	N/A
YINSAIGE	Coaxial Cable	SS402	SJ0100001	Each time	N/A
eastsheep	Coaxial Attenuator	2W-SMA-JK-18G	21060301	Each time	N/A
Weinschel	Power Splitter	1515	RA914	Each time	N/A
R&S	Wideband Radio Communication Tester	CMW500	143458	2023/3/31	2024/3/30
BACL	TEMP&HUMI Test Chamber	BTH-150-40	30174	2023/3/31	2024/3/30
UNI-T	Multimeter	UT39A+	C210582554	2022/9/29	2023/9/28
ZHAOXIN	DC Power Supply	RXN-6010D	21R6010D0912386	N/A	N/A

\* Statement of Traceability: China Certification ICT Co., Ltd (Dongguan) attests that all calibrations have been performed, traceable to National Primary Standards and International System of Units (SI).

#### Test Frequency For Each Mode:

Operation Modes	Lowest Frequency (MHz)	Middle Frequency (MHz)	Highest Frequency (MHz)
GSM	824.2	836.6	848.8
GPRS	824.2	836.6	848.8

**Test Data:**

<b>FCC§2.1046;§ 22.913 (a):RF Output Power</b>					
Test Mode	Conducted Peak Output Power(dBm)			Maximum ERP (dBm)	ERP Limit (dBm)
	Lowest Channel	Middle Channel	Highest Channel		
GSM	32.63	32.84	32.88	30.69	38.45
GPRS 1 Slot	32.76	32.56	32.61	30.57	38.45
GPRS 2 Slots	32.22	32.06	32.08	30.03	38.45
GPRS 3 Slots	30.75	30.62	30.67	28.56	38.45
GPRS 4 Slots	30.55	30.53	30.52	28.36	38.45
Note: $ERP = \text{Conducted Power(dBm)} - L_c(\text{dB}) + G_T(\text{dBd})$ $G_T(\text{dBd}) = G_T(\text{dBi}) - 2.15$					
				<b>Result:</b>	<b>Pass</b>

<b>FCC §2.1049, §22.917, §22.905:Occupied Bandwidth</b>						
Operation Mode	99% Occupied Bandwidth (MHz)			26 dB Occupied Bandwidth (MHz)		
	Low Channel	Middle channel	High Channel	Low Channel	Middle Channel	High Channel
GSM	0.24	0.239	0.239	0.263	0.262	0.277
GPRS	0.245	0.245	0.247	0.318	0.32	0.318
Note: The test plots please refer to the Plots of Occupied Bandwidth						

<b>FCC §2.1051, §22.917(a):Spurious Emissions at Antenna Terminal</b>	
<b>Result:</b>	<b>Pass, Please refer to the test plots of Spurious Emissions at Antenna Terminal.</b>

<b>FCC §2.1051, §22.917(a):Out of band emission, Band Edge</b>	
<b>Result:</b>	<b>Pass, Please refer to the test plots of Out of band emission, Band Edge.</b>

<b>FCC §2.1055, §22.355: Frequency Stability</b>					
Test Modulation:	GSM		Test Channel:	836.6	MHz
Test Item	Temperature (°C)	Voltage (V <sub>DC</sub> )	Frequency Error		Limit
			(Hz)	(ppm)	(ppm)
Frequency Stability vs. Temperature	-30	3.7	12	0.014	2.5
	-20	3.7	38	0.045	2.5
	-10	3.7	16	0.019	2.5
	0	3.7	10	0.012	2.5
	10	3.7	3	0.004	2.5
	20	3.7	31	0.037	2.5
	30	3.7	23	0.027	2.5
	40	3.7	17	0.020	2.5
	50	3.7	36	0.043	2.5
Frequency Stability vs. Voltage	20	3.3	17	0.020	2.5
	20	4.35	7	0.008	2.5
				<b>Result:</b>	<b>Pass</b>

Test Modulation:	GPRS		Test Channel:	836.6	MHz
Test Item	Temperature (°C)	Voltage (V <sub>DC</sub> )	Frequency Error		Limit
			(Hz)	(ppm)	(ppm)
Frequency Stability vs. Temperature	-30	3.7	38	0.045	2.5
	-20	3.7	27	0.032	2.5
	-10	3.7	33	0.039	2.5
	0	3.7	8	0.010	2.5
	10	3.7	7	0.008	2.5
	20	3.7	23	0.027	2.5
	30	3.7	5	0.006	2.5
	40	3.7	1	0.001	2.5
	50	3.7	5	0.006	2.5
Frequency Stability vs. Voltage	20	3.3	16	0.019	2.5
	20	4.35	3	0.004	2.5
				<b>Result:</b>	<b>Pass</b>



**Test Plots**(Note: The 14.5 dB is the Insertion loss of the RF cable, Coaxial tee connector and DC Block, which was offset into the Spectrum Analyzer):

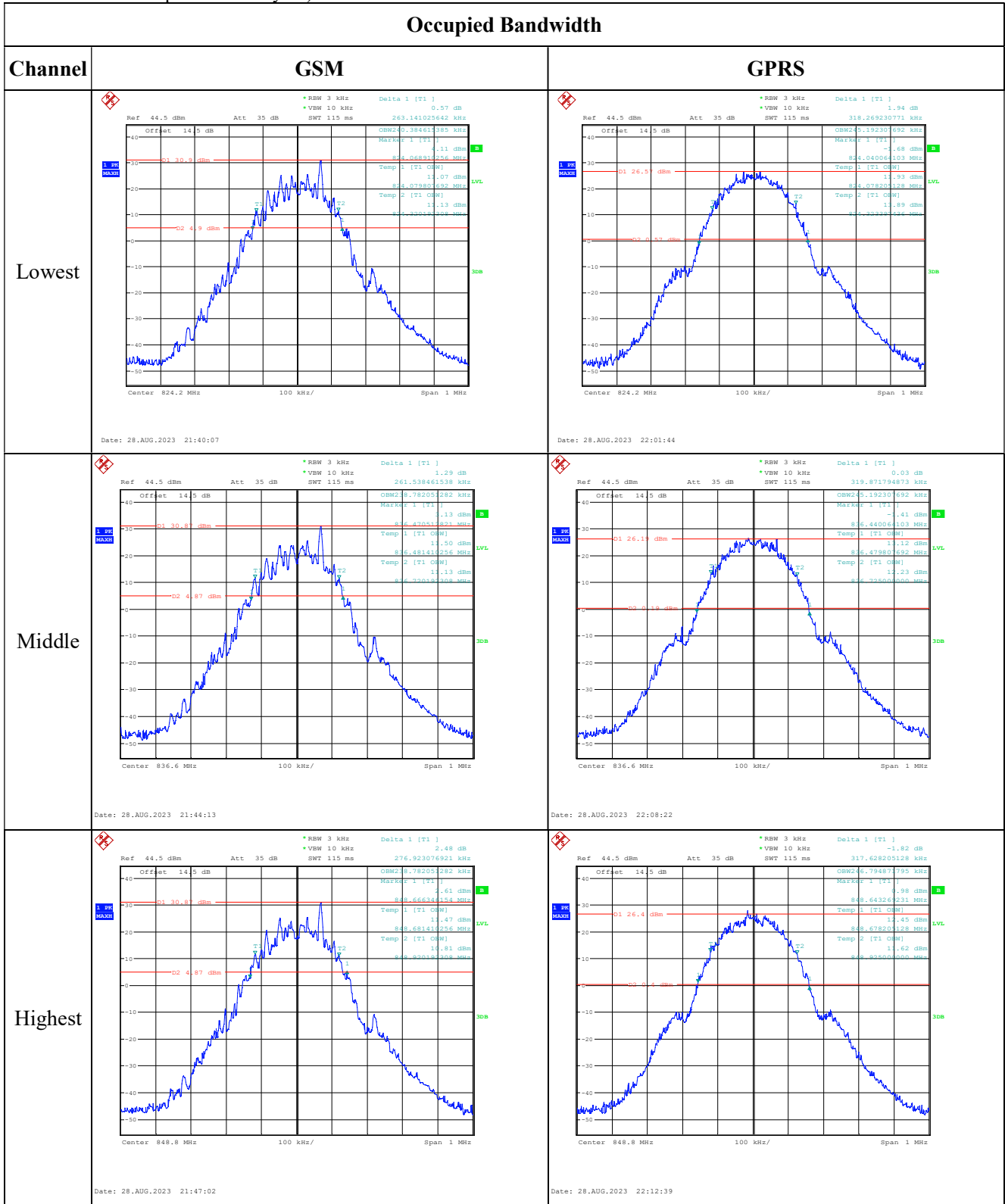

Spurious Emissions at Antenna Terminal

Channel	GSM	
Lowest	<p>Ref 44.5 dBm *Att 45 dB                      *RBW 100 kHz Marker 1 [T1] -26.36 dBm                      *VSW 300 kHz                      SWT 100 ms 947.147433597 MHz</p> <p>Offset 14.5 dB                      Start 30 MHz 97 MHz/ Stop 1 GHz</p> <p>Date: 28.AUG.2023 22:34:08</p>	<p>Ref 40 dBm *Att 35 dB                      *RBW 1 MHz Marker 1 [T1] -23.91 dBm                      *VSW 3 MHz                      SWT 55 ms 3.126000000 GHz</p> <p>Offset 14.5 dB                      Start 1 GHz 900 MHz/ Stop 10 GHz</p> <p>Date: 28.AUG.2023 22:34:34</p>
Middle	<p>Ref 44.5 dBm *Att 45 dB                      *RBW 100 kHz Marker 1 [T1] -26.31 dBm                      *VSW 300 kHz                      SWT 100 ms 560.080128205 MHz</p> <p>Offset 14.5 dB                      Start 30 MHz 97 MHz/ Stop 1 GHz</p> <p>Date: 28.AUG.2023 22:36:03</p>	<p>Ref 40 dBm *Att 35 dB                      *RBW 1 MHz Marker 1 [T1] -22.84 dBm                      *VSW 3 MHz                      SWT 55 ms 3.124000000 GHz</p> <p>Offset 14.5 dB                      Start 1 GHz 900 MHz/ Stop 10 GHz</p> <p>Date: 28.AUG.2023 22:36:23</p>
Highest	<p>Ref 44.5 dBm *Att 45 dB                      *RBW 100 kHz Marker 1 [T1] -27.29 dBm                      *VSW 300 kHz                      SWT 100 ms 277.163461538 MHz</p> <p>Offset 14.5 dB                      Start 30 MHz 97 MHz/ Stop 1 GHz</p> <p>Date: 28.AUG.2023 22:37:11</p>	<p>Ref 40 dBm *Att 35 dB                      *RBW 1 MHz Marker 1 [T1] -23.48 dBm                      *VSW 3 MHz                      SWT 55 ms 3.142000000 GHz</p> <p>Offset 14.5 dB                      Start 1 GHz 900 MHz/ Stop 10 GHz</p> <p>Date: 28.AUG.2023 22:37:26</p>

Out of band emission, Band Edge

Mode	Lowest	Highest
GSM	<p>Ref 40 dBm    Att 35 dB    RBW 3 kHz    Marker 1 [T1] -14.05 dBm            VBW 10 kHz    SWT 500 ms    Center 824 MHz    200 kHz/    Span 2 MHz</p> <p>Date: 28.AUG.2023 21:42:07</p>	<p>Ref 40 dBm    Att 35 dB    RBW 3 kHz    Marker 1 [T1] -16.54 dBm            VBW 10 kHz    SWT 500 ms    Center 849 MHz    200 kHz/    Span 2 MHz</p> <p>Date: 28.AUG.2023 21:47:37</p>
GPRS	<p>Ref 40 dBm    Att 35 dB    RBW 3 kHz    Marker 1 [T1] -15.80 dBm            VBW 10 kHz    SWT 500 ms    Center 824 MHz    200 kHz/    Span 2 MHz</p> <p>Date: 28.AUG.2023 22:03:19</p>	<p>Ref 40 dBm    Att 35 dB    RBW 3 kHz    Marker 1 [T1] -16.48 dBm            VBW 10 kHz    SWT 500 ms    Center 849 MHz    200 kHz/    Span 2 MHz</p> <p>Date: 28.AUG.2023 22:13:38</p>

**4.2 Antenna Port Test Data and Results for GSM 1900 band:**

Serial Number:	29S9-1	Test Date:	2023/8/28-2023/9/18
Test Site:	RF	Test Mode:	Transmitting
Tester:	Panda Sun	Test Result:	Pass

**Environmental Conditions:**

Temperature: (°C)	25.6-26.1	Relative Humidity: (%)	56-62	ATM Pressure: (kPa)	99.7-100.5
----------------------	-----------	------------------------------	-------	------------------------	------------

**Test Equipment List and Details:**

Manufacturer	Description	Model	Serial Number	Calibration Date	Calibration Due Date
R&S	Spectrum Analyzer	FSU26	100147	2023/3/31	2024/3/30
zhuoxiang	Coaxial Cable	SMA-178	211001	Each time	N/A
YINSAIGE	Coaxial Cable	SS402	SJ0100001	Each time	N/A
eastsheep	Coaxial Attenuator	2W-SMA-JK-18G	21060301	Each time	N/A
Weinschel	Power Splitter	1515	RA914	Each time	N/A
R&S	Wideband Radio Communication Tester	CMW500	143458	2023/3/31	2024/3/30
BACL	TEMP&HUMI Test Chamber	BTH-150-40	30174	2023/3/31	2024/3/30
UNI-T	Multimeter	UT39A+	C210582554	2022/9/29	2023/9/28
ZHAOXIN	DC Power Supply	RXN-6010D	21R6010D0912386	N/A	N/A

\* Statement of Traceability: China Certification ICT Co., Ltd (Dongguan) attests that all calibrations have been performed, traceable to National Primary Standards and International System of Units (SI).

**Test Frequency For Each Mode:**

Operation Modes	Lowest Frequency (MHz)	Middle Frequency (MHz)	Highest Frequency (MHz)
GSM	1850.2	1880	1909.8
GPRS	1850.2	1880	1909.8

**Test Data:**

<b>FCC§2.1046;§ 24.232 (c):RF Output Power</b>						
Test Mode	Conducted Peak Output Power(dBm)			Maximum EIRP (dBm)	EIRP Limit (dBm)	
	Lowest Channel	Middle Channel	Highest Channel			
GSM	30.23	30.22	30.14	30.82	33	
GPRS 1 Slot	30.25	30.23	30.21	30.84	33	
GPRS 2 Slots	29.41	29.39	29.38	30	33	
GPRS 3 Slots	27.13	27.1	27.14	27.73	33	
GPRS 4 Slots	25.54	25.52	25.51	26.13	33	
Note: EIRP=Conducted Power(dBm) - Lc(dB) + Gr(dBi)						
					<b>Result:</b>	<b>Pass</b>

<b>FCC §2.1049, §24.238:Occupied Bandwidth</b>						
Operation Mode	99% Occupied Bandwidth (MHz)			26 dB Occupied Bandwidth (MHz)		
	Low Channel	Middle channel	High Channel	Low Channel	Middle Channel	High Channel
GSM	0.239	0.239	0.239	0.267	0.279	0.262
GPRS	0.245	0.247	0.247	0.32	0.318	0.321
Note: The test plots please refer to the Plots of Occupied Bandwidth						

<b>FCC §2.1051, § 24.238 (a):Spurious Emissions at Antenna Terminal</b>	
<b>Result:</b>	<b>Pass, Please refer to the test plots of Spurious Emissions at Antenna Terminal.</b>

<b>FCC §2.1051, § 24.238 (a):Out of band emission, Band Edge</b>	
<b>Result:</b>	<b>Pass, Please refer to the test plots of Out of band emission, Band Edge.</b>

<b>FCC §2.1055, §24.235: Frequency Stability</b>						
Test Mode:	GSM	Test Channel: Lowest for Lower Edge,Highest for Upper Edge				
Test Item	Temperature (°C)	Voltage (V <sub>DC</sub> )	Lower Edge (MHz)		Upper Edge (MHz)	
			Result	Limit	Result	Limit
Frequency Stability vs. Temperature	-30	3.7	1850.057	1850.000	1909.942	1910.000
	-20	3.7	1850.060	1850.000	1909.926	1910.000
	-10	3.7	1850.074	1850.000	1909.939	1910.000
	0	3.7	1850.063	1850.000	1909.924	1910.000
	10	3.7	1850.055	1850.000	1909.937	1910.000
	20	3.7	1850.081	1850.000	1909.920	1910.000
	30	3.7	1850.058	1850.000	1909.934	1910.000
	40	3.7	1850.064	1850.000	1909.945	1910.000
	50	3.7	1850.073	1850.000	1909.934	1910.000
Frequency Stability vs. Voltage	20	3.3	1850.071	1850.000	1909.947	1910.000
	20	4.35	1850.069	1850.000	1909.935	1910.000
					<b>Result:</b>	<b>Pass</b>

Test Mode:	GPRS	Test Channel: Lowest for Lower Edge,Highest for Upper Edge				
Test Item	Temperature (°C)	Voltage (V <sub>DC</sub> )	Lower Edge (MHz)		Upper Edge (MHz)	
			Result	Limit	Result	Limit
Frequency Stability vs. Temperature	-30	3.7	1850.053	1850.000	1909.948	1910.000
	-20	3.7	1850.065	1850.000	1909.930	1910.000
	-10	3.7	1850.062	1850.000	1909.948	1910.000
	0	3.7	1850.067	1850.000	1909.934	1910.000
	10	3.7	1850.056	1850.000	1909.952	1910.000
	20	3.7	1850.080	1850.000	1909.925	1910.000
	30	3.7	1850.064	1850.000	1909.945	1910.000
	40	3.7	1850.069	1850.000	1909.930	1910.000
	50	3.7	1850.067	1850.000	1909.946	1910.000
Frequency Stability vs. Voltage	20	3.3	1850.070	1850.000	1909.950	1910.000
	20	4.35	1850.074	1850.000	1909.948	1910.000
					<b>Result:</b>	<b>Pass</b>

**Test Plots**(Note: The 14.5 dB is the Insertion loss of the RF cable, Coaxial tee connector and DC Block, which was offset into the Spectrum Analyzer):

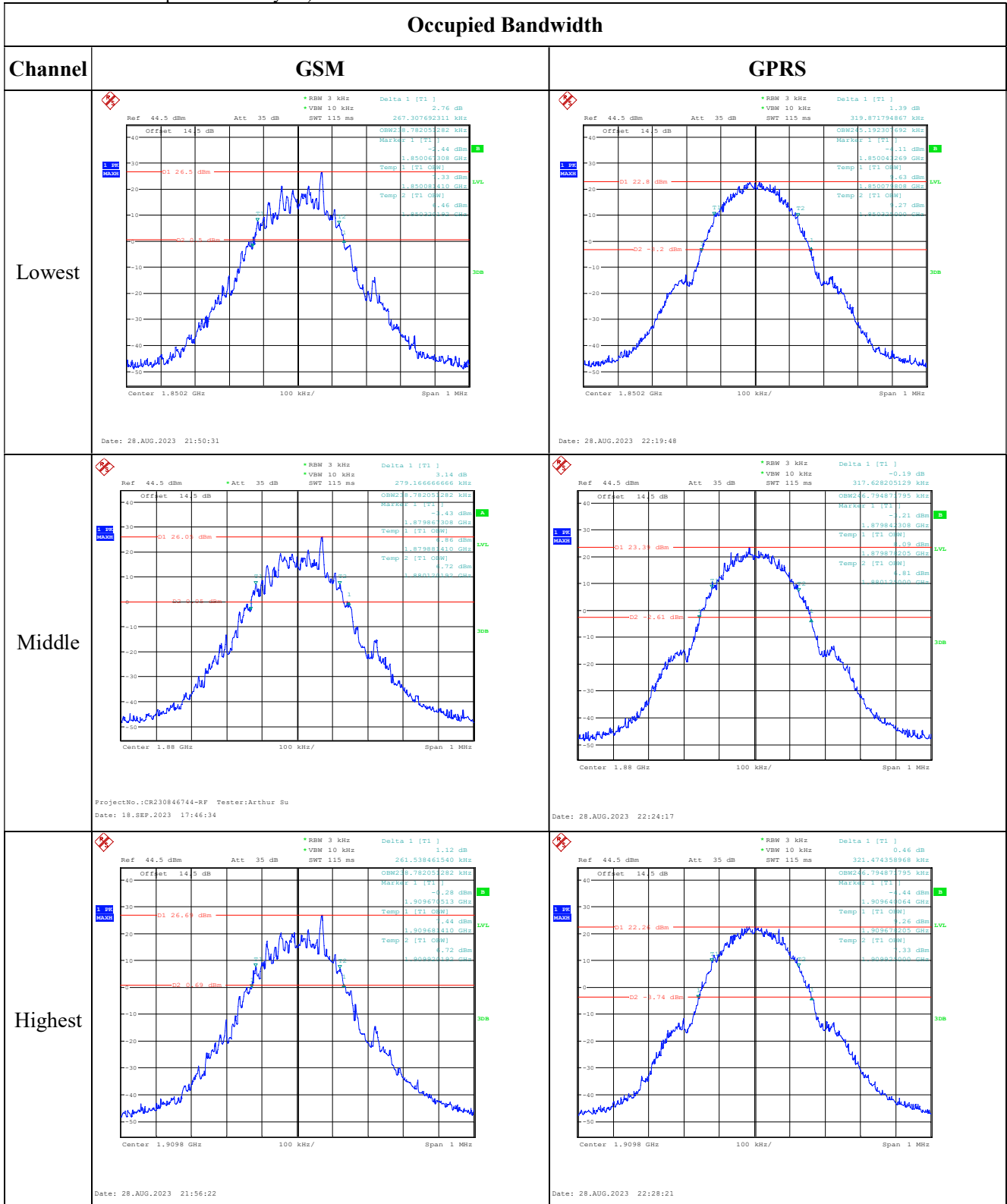

Spurious Emissions at Antenna Terminal

Channel	GSM	
Lowest		
Middle		
Highest		



Out of band emission, Band Edge

Channel	Lowest	Highest
GSM	<p>Ref 40 dBm    Att 35 dB    RBW 3 kHz    Marker 1 [T1]    -21.46 dBm            VBW 10 kHz    SWT 500 ms    1.84997487 GHz</p> <p>Center 1.85 GHz    200 kHz/    Span 2 MHz</p> <p>Date: 28.AUG.2023 21:51:37</p>	<p>Ref 40 dBm    Att 35 dB    RBW 3 kHz    Marker 1 [T1]    -20.78 dBm            VBW 10 kHz    SWT 500 ms    1.910023128 GHz</p> <p>Center 1.91 GHz    200 kHz/    Span 2 MHz</p> <p>Date: 28.AUG.2023 21:57:01</p>
GPRS	<p>Ref 40 dBm    Att 35 dB    RBW 3 kHz    Marker 1 [T1]    -21.31 dBm            VBW 10 kHz    SWT 500 ms    1.849984000 GHz</p> <p>Center 1.85 GHz    200 kHz/    Span 2 MHz</p> <p>Date: 28.AUG.2023 22:20:55</p>	<p>Ref 40 dBm    Att 35 dB    RBW 3 kHz    Marker 1 [T1]    -19.27 dBm            VBW 10 kHz    SWT 500 ms    1.910020795 GHz</p> <p>Center 1.91 GHz    200 kHz/    Span 2 MHz</p> <p>Date: 28.AUG.2023 22:29:20</p>

**4.3 Radiated Spurious Emissions**

Serial Number:	29S9-1	Test Date:	2023/8/28~2023/8/29
Test Site:	966-1, 966-2	Test Mode:	Transmitting
Tester:	Carl Xue ,Mack Huang	Test Result:	Pass

**Environmental Conditions:**

Temperature: (°C)	25.6~26.3	Relative Humidity: (%)	59~64	ATM Pressure: (kPa)	99.7
----------------------	-----------	---------------------------	-------	---------------------------	------

**Test Equipment List and Details:**

Manufacturer	Description	Model	Serial Number	Calibration Date	Calibration Due Date
Sunol Sciences	Antenna	JB6	A082520-5	2020/10/19	2023/10/18
R&S	EMI Test Receiver	ESR3	102724	2023/3/31	2024/3/30
TIMES MICROWAVE	Coaxial Cable	LMR-600-UltraFlex	C-0470-02	2023/7/16	2024/7/15
TIMES MICROWAVE	Coaxial Cable	LMR-600-UltraFlex	C-0780-01	2023/7/16	2024/7/15
Sonoma	Amplifier	310N	186165	2023/7/16	2024/7/15
EMCO	Adjustable Dipole Antenna	3121C	9109-756	N/A	N/A
MICRO-COAX	Coaxial Cable	UFA210B-0-0720-300300	99G1448	2022/7/16	2024/7/15
Agilent	Signal Generator	E8247C	MY43321352	2022/11/18	2023/11/17
ETS-Lindgren	Horn Antenna	3115	9912-5985	2020/10/13	2023/10/12
R&S	Spectrum Analyzer	FSV40	101591	2023/3/31	2024/3/30
MICRO-COAX	Coaxial Cable	UFA210A-1-1200-70U300	217423-008	2023/8/6	2024/8/5
MICRO-COAX	Coaxial Cable	UFA210A-1-2362-300300	235780-001	2023/8/6	2024/8/5
Mini	Pre-amplifier	ZVA-183-S+	5969001149	2022/11/9	2023/11/8
AH	Double Ridge Guide Horn Antenna	SAS-571	1396	2021/10/18	2024/10/17
MICRO-COAX	Coaxial Cable	UFA210B-0-0720-300300	99G1448	2022/7/16	2024/7/15
PASTERNAK	Horn Antenna	PE9852/2F-20	112002	2021/2/5	2024/2/4
PASTERNAK	Horn Antenna	PE9852/2F-20	112001	2021/2/5	2024/2/4
Quinstar	Preamplifier	QLW-18405536-JO	15964001005	2022/9/16	2023/9/15
PASTERNAK	Horn Antenna	PE9850/2F-20	072001	2021/2/5	2024/2/4
PASTERNAK	Horn Antenna	PE9850/2F-20	072002	2021/2/5	2024/2/4
MICRO-COAX	Coaxial Cable	UFB142A-1-2362-200200	235772-001	2023/8/6	2024/8/5

*\* Statement of Traceability: China Certification ICT Co., Ltd (Dongguan) attests that all calibrations have been performed, traceable to National Primary Standards and International System of Units (SI).*

**Test Data:**

Please refer to the below table and plots.

Note: The device can be mounted in multiple orientations, test was performed with X,Y, Z Axis according to C63.26 figure 5, the worst orientation was photographed and it's data was recorded.

**Cellular Band (PART 22H)****30 MHz-10 GHz:**

Frequency (MHz)	Polar (H/V)	Receiver Reading (dBμV)	Substituted Method			Absolute Level (dBm)	Limit (dBm)	Margin (dB)
			Substituted Level (dBm)	Antenna Gain (dBd/dBi)	Cable Loss (dB)			
GSM 850 Frequency:824.2MHz								
673.40	H	21.12	-52.34	0.00	0.50	-52.84	-13.00	39.84
714.97	V	20.76	-48.83	0.00	0.50	-49.33	-13.00	36.33
1648.400	H	81.96	-22.37	8.68	0.80	-14.49	-13.00	1.49
1648.400	V	79.74	-24.67	8.68	0.80	-16.79	-13.00	3.79
2472.600	H	66.58	-34.20	9.38	1.00	-25.82	-13.00	12.82
2472.600	V	62.32	-38.41	9.38	1.00	-30.03	-13.00	17.03
3296.800	H	44.49	-52.19	10.32	1.15	-43.02	-13.00	30.02
3296.800	V	44.68	-51.76	10.32	1.15	-42.59	-13.00	29.59
GSM 850 Frequency:836.6MHz								
704.37	H	21.07	-52.16	0.00	0.55	-52.71	-13.00	39.71
695.22	V	20.87	-49.14	0.00	0.55	-49.69	-13.00	36.69
1673.200	H	78.50	-25.81	8.71	0.85	-17.95	-13.00	4.95
1673.200	V	75.12	-29.29	8.71	0.85	-21.43	-13.00	8.43
2509.800	H	68.00	-32.61	9.42	1.01	-24.20	-13.00	11.20
2509.800	V	59.44	-41.18	9.42	1.01	-32.77	-13.00	19.77
3346.400	H	43.12	-54.05	10.34	1.16	-44.87	-13.00	31.87
3346.400	V	43.67	-53.36	10.34	1.16	-44.18	-13.00	31.18
GSM 850 Frequency:848.8MHz								
709.98	H	20.86	-52.26	0.00	0.52	-52.78	-13.00	39.78
725.06	V	20.93	-48.44	0.00	0.51	-48.95	-13.00	35.95
1697.600	H	75.60	-28.69	8.74	0.90	-20.85	-13.00	7.85
1697.600	V	70.55	-33.87	8.74	0.90	-26.03	-13.00	13.03
2546.400	H	69.78	-30.55	9.47	1.01	-22.09	-13.00	9.09
2546.400	V	62.91	-37.37	9.47	1.01	-28.91	-13.00	15.91
3395.200	H	43.07	-54.62	10.36	1.19	-45.45	-13.00	32.45
3395.200	V	45.89	-51.77	10.36	1.19	-42.60	-13.00	29.60

**PCS Band (PART 24E)****30 MHz-20 GHz:**

Frequency (MHz)	Polar (H/V)	Receiver Reading (dBμV)	Substituted Method			Absolute Level (dBm)	Limit (dBm)	Margin (dB)
			Substituted Level (dBm)	Antenna Gain (dBd/dBi)	Cable Loss (dB)			
GSM 1900 Frequency:1850.2MHz								
66.26	H	32.58	-71.24	-6.98	0.15	-78.37	-13.00	65.37
44.58	V	40.89	-54.87	-20.35	0.12	-75.34	-13.00	62.34
3700.400	H	41.86	-55.46	10.60	1.25	-46.11	-13.00	33.11
3700.400	V	42.76	-54.54	10.60	1.25	-45.19	-13.00	32.19
5550.600	H	46.41	-46.85	11.44	1.49	-36.90	-13.00	23.90
5550.600	V	43.29	-49.81	11.44	1.49	-39.86	-13.00	26.86
GSM 1900 Frequency:1880MHz								
66.26	H	32.82	-71.00	-6.98	0.15	-78.13	-13.00	65.13
45.21	V	40.76	-55.75	-19.59	0.12	-75.46	-13.00	62.46
3760.000	H	39.00	-57.41	10.66	1.24	-47.99	-13.00	34.99
3760.000	V	43.08	-53.21	10.66	1.24	-43.79	-13.00	30.79
5640.000	H	48.68	-44.77	11.33	1.54	-34.98	-13.00	21.98
5640.000	V	44.97	-48.36	11.33	1.54	-38.57	-13.00	25.57
GSM 1900 Frequency:1909.8MHz								
66.26	H	32.61	-71.21	-6.98	0.15	-78.34	-13.00	65.34
44.58	V	40.78	-54.98	-20.35	0.12	-75.45	-13.00	62.45
3819.600	H	42.03	-53.83	10.72	1.29	-44.40	-13.00	31.40
3819.600	V	43.78	-51.94	10.72	1.29	-42.51	-13.00	29.51
5729.400	H	47.95	-45.53	11.22	1.59	-35.90	-13.00	22.90
5729.400	V	43.21	-50.15	11.22	1.59	-40.52	-13.00	27.52

## Note:

- 1) The unit of Antenna Gain is dBd for frequency below 1GHz, and the unit of Antenna Gain is dBi for frequency above 1GHz.
- 2) Absolute Level = Substituted Level - Cable loss + Antenna Gain
- 3) Margin = Limit-Absolute Level

## 5. RF EXPOSURE EVALUATION

### 5.1 Applicable Standard

According to subpart §1.1310, systems operating under the provisions of this section shall be operated in a manner that ensures that the public is not exposed to radio frequency energy level in excess of the Commission's guidelines.

Limits for Maximum Permissible Exposure (MPE) (§1.1310, §2.1091)

(B) Limits for General Population/Uncontrolled Exposure				
Frequency Range (MHz)	Electric Field Strength (V/m)	Magnetic Field Strength (A/m)	Power Density (mW/cm <sup>2</sup> )	Averaging Time (minutes)
0.3–1.34	614	1.63	*(100)	30
1.34–30	824/f	2.19/f	*(180/f <sup>2</sup> )	30
30–300	27.5	0.073	0.2	30
300–1500	/	/	f/1500	30
1500–100,000	/	/	1.0	30

f = frequency in MHz; \* = Plane-wave equivalent power density;

According to §1.1310 and §2.1091 RF exposure is calculated.

### 5.2 Calculation formula:

Prediction of power density at the distance of the applicable MPE limit

$S = PG/4\pi R^2$  = power density (in appropriate units, e.g. mW/cm<sup>2</sup>);

P = power input to the antenna (in appropriate units, e.g., mW);

G = power gain of the antenna in the direction of interest relative to an isotropic radiator, the power gain factor, is normally numeric gain;

R = distance to the center of radiation of the antenna (appropriate units, e.g., cm);

### 5.3 Calculated Data:

Operation Modes	Frequency (MHz)	Antenna Gain		Conducted output power including Tune-up Tolerance		Evaluation Distance (cm)	Power Density (mW/cm <sup>2</sup> )	MPE Limit (mW/cm <sup>2</sup> )
		(dBi)	(numeric)	(dBm)	(mW)			
GSM850	824-849	-0.04	0.99	33.0	1995.26	20	0.393	0.549
PCS1900	1850-1910	0.59	1.15	30.5	1122.02	20	0.256	1

Note: The tune up power was declared by applicant.

Result: The device meet FCC MPE at 20 cm distance

## **6. EUT PHOTOGRAPHS**

---

Please refer to the attachment CR230846744-EXP EUT EXTERNAL PHOTOGRAPHS and CR230846744-INP EUT INTERNAL PHOTOGRAPHS

## **7. TEST SETUP PHOTOGRAPHS**

---

Please refer to the attachment CR230846744-00-TSP TEST SETUP PHOTOGRAPHS.

**\*\*\*\*\* END OF REPORT \*\*\*\*\***