

Bluetooth Stereo
Boombox with CD/
Cassette Player-
Recorder/AM-FM Radio

SB2150 OWNER'S MANUAL



WARNING

TO PREVENT FIRE OR SHOCK HAZARD, DO NOT USE THIS PLUG WITH AN EXTENSION CORD, RECEPTACLE OR OTHER OUTLET UNLESS THE BLADES CAN BE FULLY INSERTED TO PREVENT BLADE EXPOSURE. TO PREVENT FIRE OR SHOCK HAZARD, DO NOT EXPOSE THIS APPLIANCE TO RAIN OR MOISTURE.

 <p>The lightning flash with arrowhead symbol, within an equilateral triangle is intended to alert the user to the presence of uninsulated dangerous voltage within the product enclosure that may be of sufficient magnitude to constitute a risk of electric shock to persons.</p>	<p>CAUTION RISK OF ELECTRIC SHOCK DO NOT OPEN</p> <p>CAUTION TO REDUCE THE RISK OF ELECTRIC SHOCK, DO NOT REMOVE COVER (OR BACK). NO USER-SERVICEABLE PARTS INSIDE. REFER SERVICING TO QUALIFIED SERVICE PERSONNEL.</p>	 <p>The exclamation point within an equilateral triangle is intended to alert the user to the presence of important operating and maintenance (servicing) instructions in the literature accompanying the appliance.</p>
---	--	---

The Caution Marking is located at the back enclosure of the apparatus.

The Rating plate is located at the back enclosure of the apparatus.

IMPORTANT SAFETY INSTRUCTIONS

1. Read these instructions.
2. Keep these instructions.
3. Heed all warnings.
4. Follow all instructions.
5. Do not use this apparatus near water.
6. Clean only with dry cloth.
7. Do not block any ventilation openings. Install in accordance with the manufacturer's instructions.
8. Do not install near any heat sources such as radiators, heat registers, stoves, or other apparatus (including amplifiers) that product heat.
9. Do not defeat the safety purpose of the polarized or grounding-type plug. A polarized plug has two blades with one wider than the other. A grounding type plug has two blades and a third grounding prong. The wide blade or the third prong is provided for your safety. If the provided plug does not fit into your outlet, consult an electrician for replacement of the obsolete outlet.
10. Protect the power cord from being walked on or pinched particularly at plugs, convenience receptacles, and the point where they exit from the apparatus.
11. Only use attachments/accessories specified by the manufacturer.
12. Use only with a cart, stand, tripod, bracket, or table recommended by the manufacturer, or sold with the product. When a cart is used, use caution when moving the cart/apparatus combination to avoid injury from tip-over.
13. Unplug this apparatus during lightning storms or when unused for a long periods of time.
14. Refer all servicing to qualified service personnel. Servicing is required when the apparatus has been damaged in any way, such as power-supply cord or plug is damaged, liquid has been spilled or objects have fallen into the apparatus, the apparatus has been exposed to rain or moisture, does not operate normally, or has been dropped.



15. This appliance shall not be exposed to dripping or splashing water and that no object filled with liquids such as vases shall be placed on the apparatus.
16. Do not overload wall outlet. Use only power source as indicated.
17. Use replacement part as specified by the manufacturer.
18. Upon completion of any service or repairs to this product, ask the service technician to perform safety checks.
19. Power Sources - This product should be operated only from the type of power source indicated on the marking label. If you are not sure of the type of power supply to your home, consult your product dealer or local power company. For products intended to operate from battery power, or other sources, refer to the operating instruction.
20. Object and Liquid Entry - Never push objects of any kind into this product through openings as they may touch dangerous voltage points or short-out parts that could result in a fire or electric shock. Never spill liquid of any kind on the product.
21. Damage Requiring Service - Unplug this product from the wall outlet and refer servicing to qualified service personnel under the following conditions:
 - a) When the power-supply cord or plug is damaged,
 - b) If liquid has been spilled, or objects have fallen into the product,
 - c) If the product has been exposed to rain or water,
 - d) If the product does not operate normally by following the operating instructions. Adjust only those controls that are covered by the operating instructions as an improper adjustment of other controls may result in damage and will often require extensive work by a qualified technician to restore the product to its normal operation.
 - e) If the product has been dropped or damaged in any way, and
 - f) When the product exhibits a distinct change in performance - this indicates a need for service.
22. Mains plug is used as disconnect device and it should remain readily operable during intended use. In order to disconnect the apparatus from the mains completely, the mains plug should be disconnected from the mains socket outlet completely.
23. Battery shall not be exposed to excessive heat such as sunshine, fire or the like.
24. Minimum distances of 10 cm around the apparatus for sufficient ventilation.
25. The ventilation should not be impeded by covering the ventilation openings with items, such as newspapers, table-cloths, curtains, etc.
26. No naked flame sources, such as lighted candles, should be placed on the apparatus.
27. The use of apparatus in moderate climates.
28. Attention should be drawn to the environmental aspects of battery disposal.
29. CAUTION: Risk of explosion if the battery is replaced by an incorrect type.
30. High or low extreme temperatures that a battery cannot be subjected to during use, storage or transportation and low air pressure at high altitude.
31. Replacement of a battery with an incorrect type that can defeat a safeguard.
32. Disposal of a battery into fire or a hot oven, or mechanically crushing or cutting of a battery, that can result in an explosion.
33. Leaving battery in an extremely high temperature surrounding environment that can result in an explosion or the leakage of flammable liquid or gas. A battery subjected to extremely low air pressure that may result in an explosion or the leakage of flammable liquid or gas.

This symbol indicates that this product incorporates double insulation between hazardous mains voltage and user accessible parts.



CAUTION:

TO PREVENT ELECTRIC SHOCK, MATCH WIDE BLADE OF PLUG TO WIDE SLOT. FULLY INSERT THE PLUG TO MAIN POWER SOCKET.

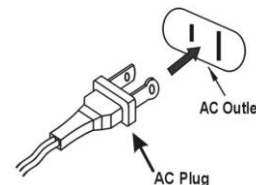

SAVE THESE INSTRUCTIONS

COMPLIANCE WITH FCC REGULATIONS

FCC ID: 2ATT8-SB2150

This device complies with Part 15 of the FCC Rules. Operation is subject to the following two conditions:

- (1) this device may not cause harmful interference, and
- (2) this device must accept any interference received, including interference that may cause undesired operation.

NOTE: This equipment has been tested and found to comply with the limits for a Class B digital device, pursuant to Part 15 of the FCC Rules. These limits are designed to provide reasonable protection against harmful interference in a residential installation. This equipment generates, uses and can radiate radio frequency energy and, if not installed and used in accordance with the instructions, may cause harmful interference to radio communications. However, there is no guarantee that interference will not occur in a particular installation. If this equipment does cause harmful interference to radio or television reception, which can be determined by turning the equipment off and on, the user is encouraged to try to correct the interference by one or more of the following measures:

- Reorient or relocate the receiving antenna.
- Increase the separation between the equipment and receiver.
- Connect the equipment into an outlet on a circuit different from that to which the receiver is connected.
- Consult the dealer or an experienced radio/TV technician for help.

RF Exposure Information

This equipment complies with FCC radiation exposure limits set forth for an uncontrolled environment. This equipment should be installed and operated with minimum distance 20cm between the radiator and your body.

CAUTION: Changes or modifications not expressly approved by the party responsible for compliance could void the user's authority to operate the equipment.

CAUTION

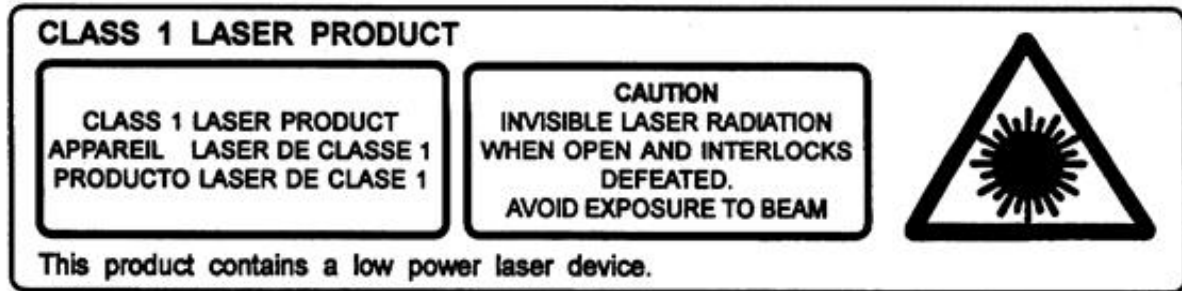

Follow the advice below for safe operations.

ON PROTECTION AGAINST LASER ENERGY EXPOSURE

- As the laser beam used in this compact disc player is harmful to the eyes, do not attempt to disassemble the casing.
- Stop operation immediately if any liquid or solid object should fall into the cabinet.
- Do not touch the lens or poke at it. If you do, you may damage the lens and the player may not operate properly.
- Do not put anything in the safety slot. If you do, the laser diode will be ON when the CD door is still open.
- If the unit is not to be used for a long period of time, make sure that all power sources are disconnected from the unit. Remove all batteries from the battery compartment.
- This unit employs a laser. The use of controls or adjustment or performance of procedures other than those specified here may result in exposure to hazardous radiation.

Should any trouble occur, remove the power source and refer servicing to qualified personnel.

PROTECT YOUR FURNITURE

This model is equipped with non-skid rubber 'feet' to prevent the product from moving when you operate the controls. These 'feet' are made from non-migrating rubber material specially formulated to avoid leaving any marks or stains on your furniture. However certain types of oil-based furniture polishes, wood preservatives, or cleaning sprays may cause the 'feet' to soften and leave marks or a rubber residue on the furniture. To prevent any damage to your furniture we strongly recommend that you purchase small self-adhesive felt pads, available at hardware stores and home improvement centers everywhere, and apply these pads to the bottom of the rubber 'feet' before you place the product on fine wooden furniture.

DEAR STUDEBAKER CUSTOMER

Selecting fine audio equipment such as the unit you've just purchased is only the start of your musical enjoyment. Now it's time to consider how you can maximize the fun and excitement your equipment offers. This manufacturer and the Electronic Industries Association's Consumer Electronics Group want you to get the most out of your equipment by playing it at a safe level. One that lets the sound come through loud and clear without annoying blaring or distortion and, most importantly, without affecting your sensitive hearing.

Sound can be deceiving. Over time your hearing "comfort level" adapts to higher volumes of sound. So what sounds "normal" can actually be loud and harmful to your hearing. Guard against this by setting your equipment at a safe level BEFORE your hearing adapts.

To establish a safe level:

- Start your volume control at a low setting.
- Slowly increase the sound until you can hear it comfortably and clearly, and without distortion.

Once you have established a comfortable sound level:

- Set the dial and leave it there.

Taking a minute to do this now will help to prevent hearing damage or loss in the future. After all, we want you listening for a lifetime.

We Want You Listening For a Lifetime

Used wisely, your new sound equipment will provide a lifetime of fun and enjoyment. Since hearing damage from loud noise is often undetectable until it is too late, this manufacturer and the Electronic Industries Association's Consumer Electronics Group recommend you avoid prolonged exposure to excessive noise.



Customer's Record:

The serial number of this product is found on its bottom. You should note the serial number of this unit in the space provided as a permanent record of your purchase to aid in identification in the event of theft or loss.

Model Number: SB2150

Serial Number:

LOCATION OF CONTROLS

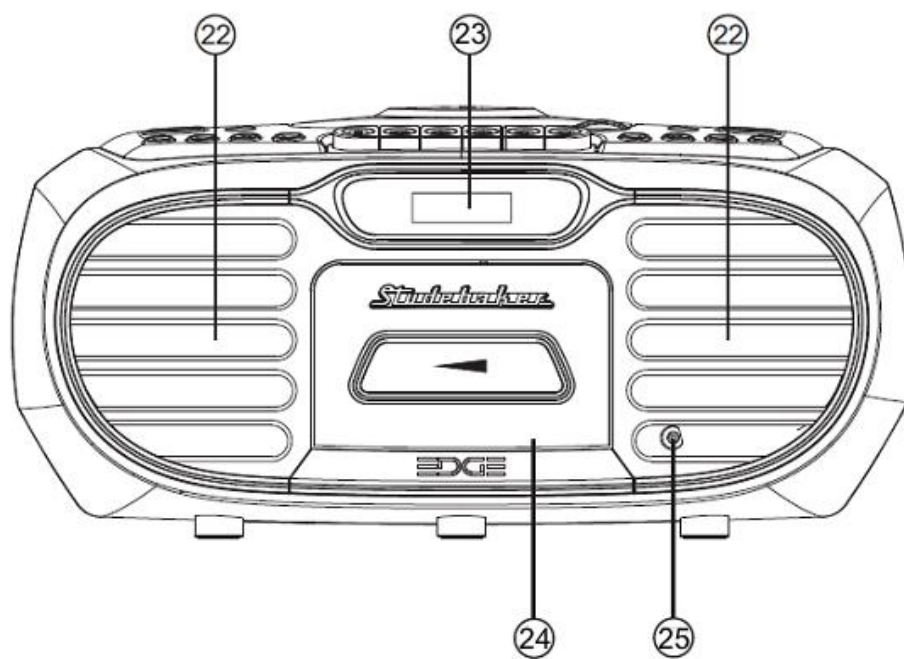
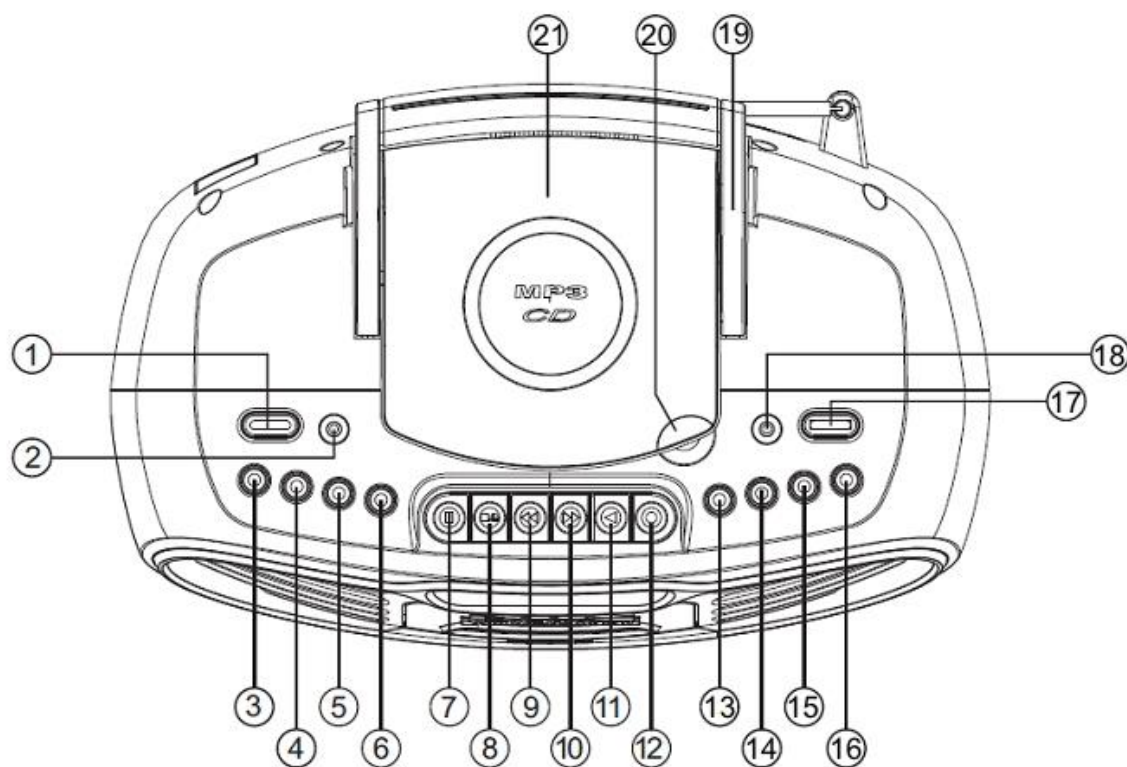

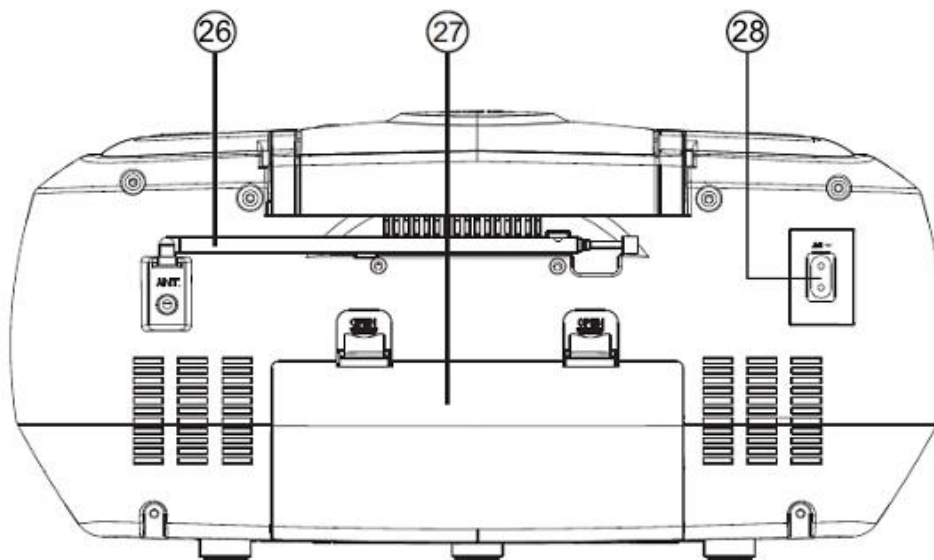

1	POWER BUTTON	15	VOLUME - BUTTON
2	PHONE JACK	16	VOLUME + BUTTON
3	REPEAT BUTTON	17	FUNCTION BUTTON
4	PROGRAM / FOLDER + BUTTON	18	AUX IN JACK
5	SKIP ◀◀	19	CARRYING HANDLE
6	SKIP ▶▶	20	CD DOOR ACCESS POINT
7	CASSETTE PAUSE BUTTON	21	CD COMPARTMENT
8	CASSETTE STOP/EJECT ■ ▲ BUTTON	22	SPEAKERS
9	CASSETTE F.FORWARD ◀◀ BUTTON	23	LCD DISPLAY
10	CASSETTE REWIND ▶▶ BUTTON	24	CASSETTE HOLDER
11	CASSETTE PLAY ◀ BUTTON	25	MICROPHONE
12	CASSETTE RECORD ● BUTTON	26	FM TELESCOPIC ANTENNA
13	CD STOP ■ BUTTON	27	BATTERY COMPARTMENT
14	PAIR / PLAY/PAUSE ▶ BUTTON	28	AC SOCKET

POWER SOURCE

The SB2150 operates using standard AC 120V~ 60Hz household power or 6 x "C" size (UM-2) batteries (Not included).

BATTERY OPERATION

NOTES:

Disconnect the AC power cord.

For best performance and longer operating time, we recommend the use of alkaline batteries.

1. Remove the Battery Door on the back of the unit.
2. Following the polarity diagram shown in the BATTERY COMPARTMENT (#27) to insert 6 X 'C' size (UM-2) batteries and close the door.

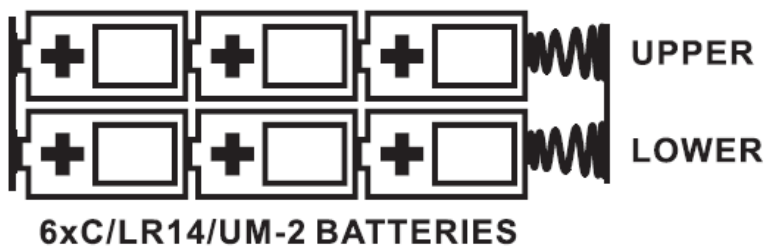

BATTERY WARNING

1. Be sure that the batteries are installed correctly. Wrong polarity may damage the unit.
2. Use only the size and type of batteries specified.
3. Only use good quality/name brand batteries.
4. Do not mix old and new batteries.
5. Do not mix alkaline, standard (carbon-zinc) or rechargeable (nickel-cadmium) batteries.
6. If the unit is not to be used for an extended period of time, remove the batteries. Old or leaking batteries can cause damage to the unit and may void the warranty.
7. Do not try to recharge batteries not intended to be recharged; they can overheat and rupture. (Follow battery manufacturer's directions).
8. Do not dispose of batteries in fire, batteries may leak or explode.

AC POWER CONNECTION

1. Insert one end of power cord to the AC SOCKET (#28) at the back of the SB2150.
2. Connect the power cord to AC power source.
3. When the unit is operated from AC power source, the internal battery source will automatically be disconnected

RADIO OPERATION

Listening to the radio:

1. Press and hold the POWER BUTTON (#1) to turn the unit on.
2. If you repeatedly tap the FUNCTION BUTTON (#17), you will step through the different modes available: CD -> FM Radio -> AM Radio -> Bluetooth (bt) -> AUX -> Cassette (CASS)
3. Tap the FUNCTION BUTTON (#17) repeatedly to select either FM or AM Radio mode.
4. The FM or AM frequency will show on the LCD display (#23).
5. **Manual Tuning:** Repeatedly tap the SKIP ◀◀ BUTTON (#5) or SKIP ▶▶ BUTTON (#6) to manually adjust the frequency.
6. **Automatic Tuning:** Press and hold the SKIP ◀◀ BUTTON (#5) or SKIP ▶▶ BUTTON (#6) to automatically tune to the previous or next available station.
7. Tap the VOL - / + BUTTONS (#15 / #16) to obtain the desired volume level.
8. Press and hold the POWER BUTTON (#1) to turn the radio off.

Notes:

- Use **Manual Tuning** to select weaker stations that might be skipped during Automatic Tuning.
- If the Automatic Tuning does not stop on the exact frequency of the station, for example, it stops on 88.9 MHz instead of 88.8 MHz, use the manual tuning method to “fine tune” to the exact frequency of the desired station.

Manual Preset Radio Stations

You can store up to total of 30 FM and 30 AM radio stations in the memory.

1. Set to FM or AM mode
2. Tune to the desired radio station by “MANUAL” or “AUTO” tuning method.
3. Press and hold the PROGRAM BUTTON (#4) until “PXX” show on the LCD DISPLAY (#23) and flashing.
4. Tap the SKIP ◀◀ BUTTON (#5) or SKIP ▶▶ BUTTON (#6) repeatedly to select select a preset number.
5. Tap the PROGRAM BUTTON (#4) again to confirm the preset.
6. Repeat step 2 to 5 to store other stations if necessary.

Auto Preset Radio Stations

1. During radio mode (AM or FM), press and hold the PLAY/PAUSE ▶|| button (#14), the unit will automatically scan the radio frequency. When the clear signal is found, it will automatically store the radio station starting from program number P01.
2. The number of stations can be found and stored is depended on the reception of different area and countries

Recalling the Preset Stations

In FM or AM radio mode, tap the PROGRAM BUTTON (#4). The preset number will show on the LCD DISPLAY (#23). Tap the SKIP ◀◀ BUTTON (#5) or SKIP ▶▶ BUTTON (#6) repeatedly to select the preset station.

NOTE:

You can overwrite a present station by storing another frequency in its place.

TIPS FOR BEST RADIO RECEPTION

AM - The AM antenna is built inside the radio. If AM reception is weak, change the position of the unit until the internal antenna picks up the strongest signal.

FM - If FM reception is weak, fully extend the FM ANTENNA (#26) and vary the position and location of the antenna until you find the strongest signal.

CD OPERATION

PLEASE READ THIS IMPORTANT INFORMATION:

CD mechanisms used in devices like this are designed to fully read all commercial CDs. They will also read self-compiled CD-R/CD-RW discs but it may take up to 10 seconds for playback to start. If playback does not start, it is likely due to the quality of the CD-R/RW disc and/or the compatibility of the CD compilation software. Manufacturer is not responsible for the playback quality of CD-R/RW discs.

Do not attach a label or seal to either side of the CD-R/RW disc. It may cause a malfunction.

FOR WINDOWS USERS:

When using the "Burn a CD" feature to create an MP3 CD in Windows, you must select the "With a CD/DVD player" option when it asks "How do you want to use the disc?" The MP3 CD will not play on this unit if you select the "Like a USB flash drive" option or if the MP3 CD is not finalized

PLAYING A COMMERCIAL CD

1. Press and hold the POWER BUTTON (#1) to turn on the unit.
2. Tap the FUNCTION BUTTON (#17) repeatedly to select CD mode.
3. Open the CD door, load a CD with the label side facing upward and close the CD door.
4. The CD will spin and start reading the disc information. When finished, the LCD DISPLAY (#23) will show the total number of tracks on the CD.
5. Press the CD PLAY/PAUSE ►|| BUTTON (#14) to start playing the CD. The current track number and time will show on the LCD DISPLAY (#23) alternately.
6. While playing, press the PLAY/PAUSE ►|| BUTTON (#14) to pause playback. The current track time will blink on the LCD DISPLAY (#23). Press the PLAY/PAUSE ►|| BUTTON (#14) again to resume playing.
7. Tap the VOLUME +/- BUTTONS (#15/16) repeatedly to the desired volume level.
8. Press the CD STOP ■ BUTTON (#13) to stop playing.
9. To turn off the unit, Press and hold the POWER BUTTON (#1).

REPEAT MODE PLAYING A COMMERCIAL CD

REPEAT 1:

When you first start playing a CD, press the REPEAT BUTTON (#3) once. The REPEAT icon will show on the LCD DISPLAY (#23). The current track playing will now repeat continuously until you stop playback or change the mode.

REPEAT ALL:

Press the REPEAT BUTTON (#3) again, the REPEAT ALL icon appears on the LCD DISPLAY (#23). All tracks on the CD will play in order and will repeat continuously

until you stop playback or change the mode.

RANDOM PLAY:

Press the REPEAT BUTTON (#3) again, the RANDOM icon will show on the LCD DISPLAY (#23). All tracks on the CD will play in random order until you stop playback or change the mode.

CANCELLING THE REPEAT MODES:

Press the REPEAT BUTTON (#3) again or until all the icons on the LCD DISPLAY (#23) turn off.

PLAYING AN CD MP3

1. Press and hold the POWER BUTTON (#1) to turn on the unit.
2. Tap the FUNCTION BUTTON (#17) repeatedly to select CD mode.
3. Open the CD DOOR and load an MP3 CD with the label or print side facing upward and close the CD door.
4. The CD will spin and start reading the disc information. When finished, the LCD DISPLAY (#23) will show the total number folders followed by the total number of tracks on the MP3 CD.
5. Press the CD PLAY/PAUSE ►|| BUTTON (#14) to start playing the MP3 CD. The current track number and time will show on the LCD DISPLAY (#23) alternately.
6. While playing, press the CD PLAY/PAUSE ►|| BUTTON (#14) to pause playback. The current track time will blink on the LCD DISPLAY (#23). Press the PLAY/PAUSE ►|| BUTTON (#14) again to resume playing.
7. Pressing the PROGRAM / FOLDER + BUTTON (#4) allows you to switch folders (if available on your MP3 CD). Repeatedly press the PROGRAM / FOLDER + BUTTON (#4) to step through all the available folders on the MP3 CD. The LCD DISPLAY (#23) will show F 01 is folder #1, F 02 is folder #2 and so on.
8. Tap the VOLUME +/- BUTTONS (#15/16) repeatedly to the desired volume level.
9. Press the CD STOP ■ BUTTON (#13) to stop playing.
10. To turn off the unit, press and hold the POWER BUTTON (#1).

REPEAT MODE PLAYING AN CD MP3

REPEAT 1:

When you first start playing a CD MP3, press the REPEAT BUTTON (#3) once. The REPEAT icon will show on the LCD DISPLAY (#23). The current track playing will now repeat continuously until you stop playback or change the mode.

REPEAT FOLDER

Press the REPEAT BUTTON (#3) again, the REPEAT FOLDER icon appears on the LCD DISPLAY (#23). All tracks in the current folder will play in order and will repeat continuously until you stop playback or change the mode

REPEAT ALL:

Press the REPEAT BUTTON (#3) again, the REPEAT ALL icon appears on the LCD DISPLAY (#23). All tracks on the CD MP3 will play in order and will repeat continuously until you stop playback or change the mode.

RANDOM PLAY:

Press the REPEAT BUTTON (#3) again, the RANDOM icon will show on the LCD

DISPLAY (#23). All tracks on the CD MP3 will play in random order until you stop playback or change the mode.

CANCELLING THE REPEAT MODES:

Press the REPEAT BUTTON (#3) again or until all the icons on the LCD DISPLAY (#23) turn off.

SKIP AND SEARCH MODE (COMMERCIAL CD and CD MP3)

1. During Play or Pause mode, tap the SKIP ►► BUTTON (#6) or SKIP ◀◀ BUTTON (#5) to go to the next track or go back to the beginning of the current track.
2. During play mode or Pause mode, press and hold the the SKIP ►► BUTTON (#6) or SKIP ◀◀ BUTTON (#5) to search within the current track at high speed playback.
3. During CD MP3 Play mode, press and hold the PROGRAM / FOLDER + BUTTON (#4), to go to the next folder.

PROGRAM PLAY MODE (COMMERCIAL CD and CD MP3)

This function allows music tracks to be played in a programmed sequence.

NOTE: Program can only be set in STOP mode.

1. Tap the PROGRAM / FOLDER + BUTTON (#4) once. The program number P01 and the "MEMORY" will blink on the LCD DISPLAY (#23).
2. Press the SKIP ►► BUTTON (#6) or SKIP ◀◀ BUTTON (#5) to select the track to be programmed.
3. Press the PROGRAM / FOLDER + BUTTON (#4) again to store the selection. The program number will advance to P02 and flash to prompt for the next input.
4. You may repeat steps 2 to 3 to program up to:
5. 20 tracks when playing a COMMERCIAL CD or
6. 99 tracks or when playing an CD MP3.
7. Once the storage capacity has been reached, "FULL" will show on the LCD DISPLAY (#23).
8. Press the CD PLAY/PAUSE ►|| BUTTON (#14) to start program play. "MEMORY" will appear on the LCD DISPLAY (#23).
9. Press the PLAY/PAUSE ►|| BUTTON (#14) again to stop the playback while retaining the program.
10. To play the programmed back again, press the PLAY/PAUSE ►|| BUTTON (#14).
11. To delete the program, press the STOP ■ BUTTON (#13) twice. "MEMORY" will turn off on the LCD DISPLAY (#23).

NOTES:

- If skipping occurs during CD play, try turning the volume down.
- Do not open the CD DOOR when a CD is playing.

BLUETOOTH OPERATION

Pairing a Bluetooth enabled device with the SB2150.

1. Press and hold the POWER BUTTON (#1) to turn on the unit.
2. Tap the FUNCTION BUTTON (#17) repeatedly to select Bluetooth Mode.
3. "bt" will blink on the LCD DISPLAY (#23).
4. Turn on the Bluetooth function of your device and enable the search or scan function to find the SB2150.
5. Select the SB2150 from the device list when it appears on your device's screen. If required, enter the pass code "0000" to pair (link) the SB2150 with your device.
6. If you are pairing (linking) your computer to the SB2150 using Bluetooth, you may need to set the SB2150 as your computer's default sound device.
7. After pairing the SB2150 with your Bluetooth device successfully, the "bt" will light steadily.
8. If you want the SB2150 to pair with another Bluetooth device, press and hold the PAIR / PLAY/PAUSE ►|| BUTTON (#14) until the "bt" blink on the LCD DISPLAY (#23). The unit will go into Pairing/Discoverable mode.
9. Repeat steps 4 & 5.

Now you can play music from your Bluetooth device wirelessly to the SB2150

1. Select a song and press the Play/Pause Button on your Bluetooth device or PLAY/PAUSE (#14) on the SB2150 to play or pause the Bluetooth device playback.
2. Tap the SKIP BACKWARD BUTTON (#5) or SKIP FORWARD BUTTON (#6) to select the Previous or Next track.
3. Slowly adjust both the volume controls on the SB2150 and on the Bluetooth device until you reach a comfortable listening level.

Notes:

- Refer to the manual of your cell phone, tablet PC, computer or other Bluetooth enabled devices for Bluetooth operation since it may vary from model to model.
- If your Bluetooth enabled device does not support A2DP profile, it will not play the music through the speaker, even if paired (linked).
- Remember to turn off the SB2150 when you have finished listening.
- Don't forget to switch off the power of your Bluetooth device as well.

AUX OPERATION

This unit provides an AUX IN JACK (#18) for connecting external audio devices like MP3 players, CD players, smart phones and iPods (except iPod shuffle 3rd generation) to listen to your external source through the speakers of this system.

1. You need an audio cable (not included) with one 3.5 mm stereo plug on each end of the cable.
2. Plug one end of the cable into the AUX IN JACK (#18) located on the top right side of the unit and the other end of the cable into the Line-out Jack or Headphone Jack of your external audio device.
3. Turn on the external audio device.
4. Turn on the unit and tap the FUNCTION BUTTON (#17) repeatedly to select AUX Mode. The "AUX" will show on the LCD DISPLAY (#23).
5. The volume level can now be controlled through the VOLUME – BUTTON (#15) and VOLUME + BUTTON (#16) of the unit. Operate all other functions on the

auxiliary device as usual.

6. Press and hold the POWER BUTTON (#1) to turn off the unit.

Notes:

- If you connected the Line-out Jack of your external device then you only need to adjust the volume control of this system. If you connected the Headphone Jack of your external device then you may need to adjust both the volume control of your external device and the volume control of this system to find the most desirable volume setting.
- Remove the audio cable from AUX IN JACK (#18) when you finish listening. Don't forget to switch off the power on your external device as well.

TAPE OPERATION

Playing a tape

1. Press and hold the POWER BUTTON (#1) to turn on the unit.
2. Tap the FUNCTION BUTTON (#17) repeatedly to select cassette mode.
3. Press STOP/ EJECT ■ ▲ BUTTON (#8) to open the CASSETTE HOLDER (#24).
4. Insert a tape and close the CASSETTE HOLDER (#24).
5. Press CASSETTE PLAY ◀ BUTTON (#11) to start playback.
6. Tap the VOLUME -/+ BUTTONS (#15/16) repeatedly to the desired volume level.
7. To pause playback, press the CASSETTE PAUSE || BUTTON (#7). Press the CASSETTE PAUSE || BUTTON (#7) again to resume playback.
8. To stop playback, press CASSETTE STOP/ EJECT ■ ▲ BUTTON (#8).
9. To search backward or forward, press REW. ▶▶ BUTTON or F.FWD ◀◀ BUTTON (#10 or #9) and press CASSETTE PLAY ◀ BUTTON (#11) or CASSETTE STOP/ EJECT ■ ▲ BUTTON (#8) at the point you want stop.

Recording from CD/FM/AM/BT/AUX

1. Press and hold the POWER BUTTON (#1) to turn on the unit.
2. Press CASSETTE STOP/EJECT ■ ▲ BUTTON (#8) to open the CASSETTE HOLDER (#24).
3. Insert a tape and close the CASSETTE HOLDER (#24).
4. Tap the FUNCTION BUTTON (#17) repeatedly to select CD, FM, AM, Bluetooth or AUX mode which you want to record.
In CD mode, start to playback the CD.
In radio (FM or AM) mode, tune to your desired radio station.
In Bluetooth mode, start playback from your Bluetooth device.
In AUX mode, start playback from your auxiliary source.
5. Press CASSETTE RECORD ● BUTTON (#12). CASSETTE PLAY ◀ BUTTON (#11) is depressed automatically.
6. To pause recording, press CASSETTE PAUSE || BUTTON (#7). Press the CASSETTE PAUSE || BUTTON (#7) again to resume recording.
7. To stop recording, press CASSETTE STOP/EJECT ■ ▲ BUTTON (#8).
8. To listen to your recording, tap the FUNCTION BUTTON (#17) repeatedly to select cassette mode. Press REW. ▶▶ BUTTON (#10) to rewind the tape to search your recording, then press PLAY ◀ BUTTON (#11) to listen.

Recording from the built-in microphone

1. Press and hold the POWER BUTTON (#1) to turn on the unit.
2. Tap the FUNCTION BUTTON (#17) repeatedly to select cassette mode. CASS will light on the LCD DISPLAY (#23).
2. Press STOP/EJECT ■▲ BUTTON (#8) to open the CASSETTE HOLDER (#24).
3. Insert a tape and close the CASSETTE HOLDER (#24).
4. Press RECORD ● BUTTON (#12). PLAY ◀ BUTTON (#11) is depressed automatically.
5. To pause recording, press the PAUSE || BUTTON (#7). Press the PAUSE || BUTTON (#7) again to resume recording.
6. To stop recording, press the STOP/EJECT ■▲ BUTTON (#8).
7. To listen to your recording, tap the FUNCTION BUTTON (#17) repeatedly to select cassette mode. Press REW. ▶▶ BUTTON (#10) to rewind the tape to search your recording, then press PLAY ◀ BUTTON (#11) to listen.

Note: The Built-in MICROPHONE (#25) is located on the front right of the unit. Place the recorder near the sound source to be recorded.

CARE AND MAINTENANCE

1. Do not subject the unit to excessive force, shock, dust or extreme temperature.
2. Do not tamper the internal components of the unit.
3. Clean your unit with a dry cloth. Solvent or detergent should never be used.
4. Avoid leaving your unit in direct sunlight or in hot, humid or dusty places.
5. Keep your unit away from heating appliances and sources of electrical noise such as fluorescent lamps or motors.
6. If drop-outs or interruptions occur in the music during CD play, or if the CD fails to play at all, its bottom surface may require cleaning. Before playing, wipe the disc from the center outwards with a good soft cleaning cloth

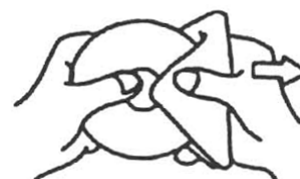

ABOUT CASSETTE TAPES

Whenever you record on a cassette any previously recorded material is erased as the new material is recorded. To prevent you from accidentally erasing material which you wish to save, blank cassettes are equipped with erase prevention tabs for each side of the tape. If the erase prevention tab for side A is removed, you cannot accidentally record on side A. The Record ● key cannot be depressed if the erase prevention tab on the cassette has been removed.

To prevent accidental erasing on side A of a cassette use a small screw driver or similar tool to break off the erase prevention tab for side A. This prevents the record key from locking.

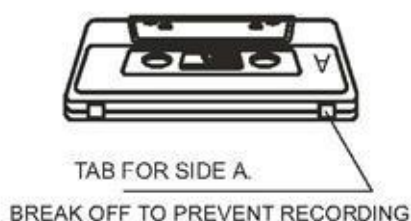

If later you do wish to record on side A of the cassette, cover the tab opening with a piece of cellophane tape. This will allow the Record ● to function again.

CASSETTE CARE

Two common causes of trouble experienced when using cassettes are:

- 1) Tape Jamming – Leading to uneven speed in playback, and
- 2) Tape Tangling – Where the tape wraps itself around vital parts of the mechanism.

To reduce the likelihood of these problems occurring, the following precautions should be observed:

- Check that there are no loose layers of tape visible through the cassette center window (see Fig. 1). Take up any loose layers, using a pencil or hexagonal barreled ballpoint pen, before inserting the cassette into the machine (see Fig.2)

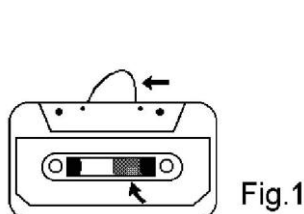

- If the cassette feels tight while performing operation shown (see Fig.2), the tape may be jamming due to ridges formed in the winding of the tape (visible through the center window). These may be removed, in most cases, by fast winding of the cassette from one end to the other and back again.
- Use only well-known brands of tape. Avoid use of C-120 cassettes.

Furthermore, do not expose cassettes to direct sunlight, dust or oil, and do not touch the tape surfaces.

HEAD CLEANING

The tape heads, pinch roller and capstan require periodic cleaning. This removes particles of the metal oxide coating that wear off the tape and accumulate on these parts and impair performance. Switch off the power, press the STOP/EJECT ■ ▲ BUTTON (#8) to open the cassette door, and press the PLAY ◀ BUTTON (#11). Clean the tape heads, pinch roller and capstan with a soft cloth or cotton pad dampened in isopropyl alcohol or special tape head cleaner.

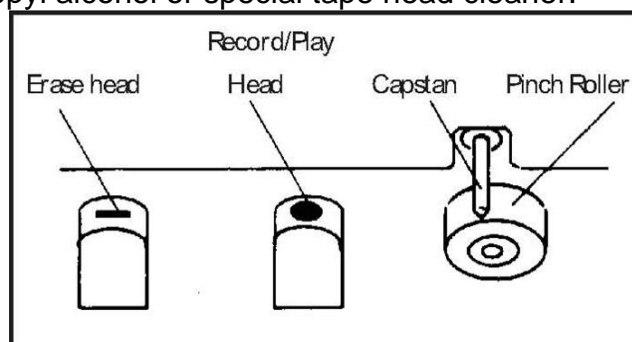

1. Avoid operating your unit under direct sunlight or in hot, humid or dusty places.
2. Keep your unit away from heating appliances and sources of electrical noise such as fluorescent lamps or motors.
3. For better Display clarity, avoid operating the unit under direct sunlight or in strong room illumination.

4. Unplug the unit from the electrical power outlet immediately in case of malfunction.

TROUBLE SHOOTING

If you experience difficulties in the use of this music system, please check the followings or call 1-800-777-5331 for Customer Service.

Symptom	Possible Cause	Solution
Noise or sound distorted on AM or FM broadcast.	<ul style="list-style-type: none"> - Station not tuned properly for AM or FM. - FM: Telescopic antenna is not extended. - AM: The bar antenna is not positioned correctly. 	<ul style="list-style-type: none"> - Retune the AM or FM broadcast station. - Fully extend the FM telescopic antenna. - Reposition the unit until the best reception is obtained.
AM or FM no sound.	<ul style="list-style-type: none"> - Unit not set to AM or FM band. - Volume at minimum. 	<ul style="list-style-type: none"> - Select AM or FM Mode - Increase Volume.
CD player will not play.	<ul style="list-style-type: none"> - Unit not in CD function mode. - CD is inserted incorrectly. - If the CD is self-compiled, the media used may not be compatible with the player. 	<ul style="list-style-type: none"> - Select CD function mode. - Insert CD with label side up. - Use better quality blank media and retest.
CD skips while playing	Disc is dirty or scratched.	Wipe CD with clean cloth or use another disc.
CD Intermittent sound	<ul style="list-style-type: none"> - Dirty or defective disc. - Dirty Pick Up lens. - Player is subject to excessive shock or vibration 	<ul style="list-style-type: none"> - Clean or replace the defective disc. - Use a CD-lens cleaning disc to clean the lens. - Relocate the player away from shock or vibration
Tape Playback muffled or fuzzy	Tape head dirty	Clean tape head using head cleaning cassette
Cassette Player no sound	<ul style="list-style-type: none"> - Unit not at TAPE function mode - Volume at minimum 	<ul style="list-style-type: none"> - SELECT Cassette Mode - Increase volume
Sound distorted	Dirty tape head	Clean the head
Speed varies	<ul style="list-style-type: none"> - Tape old or worn - Dirty roller and capstan 	<ul style="list-style-type: none"> - Replace the tape - Clean roller and capstan
Cassette Recorder will not record	Prevention tab removed	Cover hole with tape
Distorted sound on playback	Defective tape or dirty tape head	Replace tape or clean tape head
Sound appears distorted at high volume setting	Volume control is set to maximum.	Adjust Volume control to a lower comfortable level.

SPECIFICATION

POWER SUPPLY AC 120V~ 60Hz, 14 W
 DC 6 x1.5V[⊖] type R14/ UM-2/ "C" size batteries (not included)

FREQUENCY RANGE FM 88 -108 MHz

90 DAY LIMITED WARRANTY AND SERVICE VALID IN THE U.S.A. ONLY

SPECTRA MERCHANDISING INTERNATIONAL, INC. warrants this unit to be free from defective materials or factory workmanship for a period of 90 days from the date of original customer purchase and provided the product is utilized within the U.S.A. This warranty is not assignable or transferable. Our obligation under this warranty is the repair or replacement of the defective unit or any part thereof, except batteries, when it is returned to the SPECTRA Service Department, accompanied by proof of the date of original consumer purchase, such as a duplicate copy of a sales receipt.

You must pay all shipping charges required to ship the product to SPECTRA for warranty service. If the product is repaired or replaced under warranty, the return charges will be at SPECTRA's expense. There are no other express warranties other than those stated herein. This warranty is valid only in accordance with the conditions set forth below:

1. The warranty applies to the SPECTRA product only while:
 - a. It remains in the possession of the original purchaser and proof of purchase is demonstrated.
 - b. It has not been subjected to accident, misuse, abuse, improper service, usage outside the descriptions and warnings covered within the user manual or non-SPECTRA approved modifications.
 - c. Claims are made within the warranty period.
2. This warranty does not cover damage or equipment failure caused by electrical wiring not in compliance with electrical codes or SPECTRA user manual specifications, or failure to provide reasonable care and necessary maintenance as outlined in the user manual.
3. Warranty of all SPECTRA products applies to residential use only and is void when products are used in nonresidential environment or installed outside the United States.

This warranty gives you specific legal rights, and you may also have other rights which vary from state to state. TO OBTAIN SERVICE please remove all batteries (if any) and pack the unit carefully and send it freight prepaid to SPECTRA at the address shown below. IF THE UNIT IS RETURNED WITHIN THE WARRANTY PERIOD shown above, please include a proof of purchase (dated cash register receipt) so that we may establish your eligibility for warranty service and repair of the unit without cost. Also include a note with a description explaining how the unit is defective. A customer service representative may need to contact you regarding the status of your repair, so please include your name, address, phone number and email address to expedite the process.

IF THE UNIT IS OUTSIDE THE WARRANTY PERIOD, please include a check for **\$45.00** to cover the cost of repair, handling and return postage. All out of warranty returns must be sent prepaid.

It is recommended that you contact SPECTRA first at 1-800-777-5331 or by email at custserv@spectraintl.com for updated information on the unit requiring service. In some cases, the model you have may be discontinued, and SPECTRA reserves the right to offer alternative options for repair or replacement.

SPECTRA MERCHANDISING INTERNATIONAL, INC.
4230 North Normandy Avenue,
Chicago, IL60634, USA. 1-800-777-5331

To register your product, visit the link on the website below to enter your information.
<http://www.spectraintl.com/wform.htm>