

Fitting

Rotate the earhook hinge and slide the earhook behind your ear until it rests gently over the top of your ear.

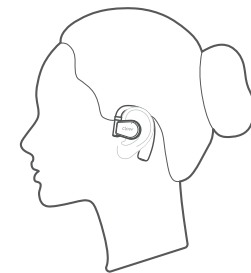

The Cleer+ app gives you a more customized control to your ARC II, download the Cleer+ app from the App Store (for iOS devices) or Google Play (for Android devices).



Power on/off



1. ARC II will auto-power on when open the case lid.



2. ARC II will auto-power off when put ARC II back the case and close the case lid.



3. Without the carry case:
 a. Long press either left or right earbud until you hear the voice prompt announce "Power off", both earbuds will power off.
 b. Long press left and right earbuds respectively until you hear the voice prompt announce "Power on", earbud will power on.

Bluetooth pairing

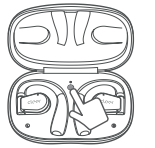

1. Put both earbuds in the case, long press the pairing button in the case until LED on the earbud blinks red and white.

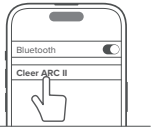

2. Select "Cleer ARC II" on the Bluetooth device list to pair the earbuds.

* When open the case lid for the first time, ARC II will automatically go into the pairing mode and LED on the earbud blinks red and white
 ** ARC II will disconnect Bluetooth connection when put ARC II in the case, ARC II will auto-power off if the earbud is not removed or placed within 30s

Earbuds control (Playback and call)

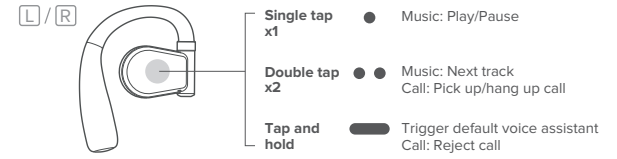

Head smart control (Music/Call)

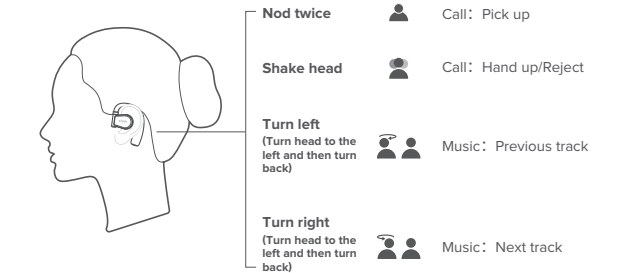

Earbuds control (Volume)

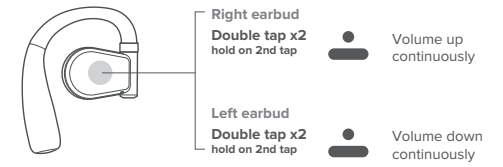

LED behavior

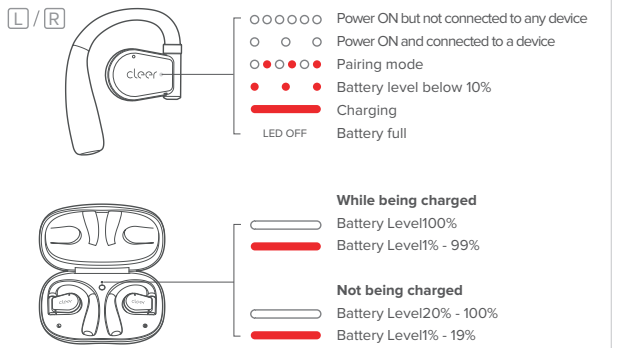

Charging

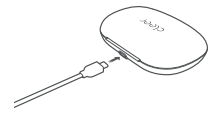

Connect ARC II to a power source with the provided USB-C cable.

10 minutes of charge time equals 1 hour of playtime, up to 8 hours of playtime when earbuds fully charged. extra 27 hours with carry case.

Specifications

Model:	ARC II
Product name:	Smart Open Ear True Wireless Headphone
Driver:	16.2mm neodymium dynamic driver
Audio CODEC support:	aptX Lossless, aptX Adaptive, AAC, SBC
Frequency response range:	20 - 20,000Hz
Connections:	USB-C cable for charging, Charging current 5V/2A
Battery charging (earbuds):	A 10-minute charge will give 1 hour of playtime; less than 2 hours for a full charge (when charging via the USB-C cable provided).
Playback time:	Up to 8hours*, in total 27 hours with carry case
Support:	Bluetooth 5.3, A2DP v1.3.2, AVRCP v1.6.2, HFP v1.8
Weight:	14g (per earbud), 130g (both earbuds and case)

*The data comes from Cleer Professional Lab. The playtime is tested by SBC-encoded audio at 75% volume on Apple mobile device. The specific battery life will vary depending on the volume, connected devices, and usage habits. Please refer to the actual usage.

OWN THE MOMENT

Find this user manual on www.cleeraudio.com

Follow us on social media



WARRANTY

Cleer Limited Warranty

Cleer Limited warrants this product against defects in material or workmanship for (1) year as set forth below when purchased directly from Cleer Limited or a Cleer Limited retailer. Pursuant to this Limited Warranty, Cleer Limited will, at its option, (i) repair the product using new or refurbished parts or (ii) replace the product with a new or refurbished product. For purposes of this Limited Warranty, "refurbished" means a product or part that has been returned to its original specifications. In the event of a defect, these are your exclusive remedies.

Labor: For a period of (1) year from the original date of purchase of the product ("Labor Warranty"), Cleer Limited will, at its option, repair or replace with new or refurbished product, product determined to be defective. If Cleer Limited elects to replace the product after this Labor Warranty has expired but while the parts warranty is still in effect, it will do so for the applicable labor charge.

Parts: For a period of (1) year from the original date of purchase of the product ("Parts Warranty"), Cleer Limited will supply new or refurbished replacement parts in exchange for parts determined to be defective.

This Limited Warranty covers only the hardware components packaged with the Product. It does not cover technical assistance for hardware or software usage and it does not cover any software products whether or not contained in the Product; any such software is provided "AS IS" unless expressly provided for in any enclosed software Limited Warranty. Please refer to the End User License Agreements included with the Product for your rights and obligations with respect to the software.

Instructions: To obtain warranty service, you must deliver the Product, freight prepaid, in either its original packaging or packaging affording an equal degree of protection to the original Cleer Limited retailer (point of purchase) or Cleer Limited Customer Service. It is your responsibility to backup any data, software or other materials you may have stored or preserved on your unit. It is unlikely that such data, software or other materials will be lost or reformatted during service and Cleer Limited will not be responsible for any such damage or loss. A dated purchase receipt from Cleer Limited or a Cleer Limited retailer is required. For specific instructions on how to obtain warranty service for your product,

Visit the Cleer Limited website: www.cleeraudio.com

Following warranty service your original Product or a replacement Product will be returned to you as your Product was configured when originally purchased.

Repair / Replacement Warranty: This Limited Warranty shall apply to any repair, replacement part or replacement product for the remainder of the original Limited Warranty period or for (90) days, whichever is longer. Any parts or product replaced under this Limited Warranty will become property of Cleer Limited.

This Limited Warranty shall not apply to: (a) consumable parts, such as batteries that are designed to diminish over time, unless failure has occurred due to a defect in materials or workmanship; (b) cosmetic damage, including but not limited to scratches, dents and broken plastic on ports; (c) defects caused by normal wear and tear or otherwise due to the normal aging of the device; (d) damage caused by accident, negligence, abuse, misuse, fire, earthquakes, acts of God or damage resulting from liquid outside of the approved levels; (e) damage caused by operating the device outside Cleer Limited published guidelines; (f) damage caused by service performed by anyone who is not a representative of Cleer Limited or a Cleer Limited authorized service provider; (g) Products whose seals are tampered; (h) Products whose serial numbers have been removed or defaced from such Product; (i) modifications, alterations or repairs to the Product made by a party other than Cleer Limited or a party authorized by Cleer Limited; (j) any failure by End User or a third party to comply with environmental and storage requirements for the Product specified by Cleer Limited, including, without limitation, temperature or humidity ranges; or (k) use of the Product in combination with any third-party devices or products that have not been provided or recommended by Cleer Limited.

LIMITATION ON DAMAGES: CLEER LIMITED SHALL NOT BE LIABLE FOR ANY INCIDENTAL OR CONSEQUENTIAL DAMAGES FOR BREACH OF ANY EXPRESS OR IMPLIED WARRANTY ON THIS PRODUCT.

DURATION OF IMPLIED WARRANTIES: EXCEPT TO THE EXTENT PROHIBITED BY APPLICABLE LAW, ANY IMPLIED WARRANTY OF MERCHANTABILITY OR FITNESS FOR A PARTICULAR PURPOSE ON THIS PRODUCT IS LIMITED TO THE DURATION OF THIS WARRANTY.

DISCLAIMER: THE LIMITED WARRANTY SET FORTH HEREIN IS EXCLUSIVE AND IN LIEU OF ALL OTHER WARRANTIES OR CONDITIONS RELATING TO THE PRODUCT, WHETHER EXPRESS OR IMPLIED, AND CLEER LIMITED EXPRESSLY DISCLAIMS ALL OTHER WARRANTIES AND CONDITIONS WHETHER EXPRESS, IMPLIED OR STATUTORY, INCLUDING ANY IMPLIED WARRANTIES OF MERCHANTABILITY, NON-INFRINGEMENT, FITNESS FOR A PARTICULAR PURPOSE, AND ANY WARRANTIES ARISING OUT OF COURSE OF DEALING OR USAGE OF TRADE AND AGAINST HIDDEN DEFECTS, TO THE FULLEST EXTENT PERMITTED BY LAW. CLEER LIMITED DOES NOT WARRANT THAT THE PRODUCT WILL MEET CUSTOMER'S REQUIREMENTS OR THAT USE OF THE PRODUCT WILL BE UNINTERRUPTED OR ERROR FREE. NO ADVICE OR INFORMATION, WHETHER ORAL OR WRITTEN, OBTAINED FROM CLEER LIMITED OR ELSEWHERE WILL CREATE ANY WARRANTY NOT EXPRESSLY STATED IN THIS WARRANTY.

NOTICE

Recycling



Your product is designed and manufactured with high quality materials and components, which can be recycled and reused. When you see the crossed out wheel bin symbol attached to a product, it means the product is covered by the European Directive 2002/96 EC:



Never dispose of your product with other household waste. Please inform yourself about the local rules on the separate collection of electrical and electronic products. The correct disposal of your old product helps prevent potentially negative consequences on the environment and human health. Your product contains batteries covered by the European Directive 2006/66/EC, which cannot be disposed of with normal household waste.

The device complies with RF specifications when the device used at 0mm from your body. Hereby, Cleer Limited. Declares that the product compliance with essential requirements and other relevant provisions of Directive 2014/53/EU.

Compliance with FCC rules

1. This device complies with Part 15 of the FCC Rules. Operation is subject to the following two conditions:

(1) This device may not cause harmful interference.

(2) This device must accept any interference received, including interference that may cause undesired operation.

2. Changes or modifications not expressly approved by the party responsible for compliance could void the user's authority to operate the equipment.

NOTE: This equipment has been tested and found to comply with the limits for a Class B digital device, pursuant to Part 15 of the FCC Rules. These limits are designed to provide reasonable protection against harmful interference in a residential installation.

This equipment generates uses and can radiate radio frequency energy and, if not installed and used in accordance with the instructions, may cause harmful interference to radio communications. However, there is no guarantee that interference will not occur in a particular installation. If this equipment does cause harmful interference to radio or television reception, which can be determined by turning the equipment off and on, the user is encouraged to try to correct the interference by one or more of the following measures:

- Reorient or relocate the receiving antenna.
- Increase the separation between the equipment and receiver.

- Connect the equipment into an outlet on a circuit different from that to which the receiver is connected.
- Consult the dealer or an experienced radio/TV technician for help.

Radiation Exposure Statement:

This equipment complies with FCC radiation exposure requirement. The device can be used in portable exposure condition without RF restriction.

Register your product and get support at www.cleeraudio.com

©2023 Cleer Limited. All rights reserved.

The Bluetooth® word mark and logos are registered trademarks owned by Bluetooth SIG, Inc. and any use of such marks by Cleer Limited is under license. Other trademarks and trade names are those of their respective owners.

Qualcomm aptX is a product of Qualcomm Technologies International, Ltd. Qualcomm is a trademark of Qualcomm Incorporated, registered in the United States and other countries, used with permission. aptX is a trademark of Qualcomm Technologies International, Ltd., registered in the United States and other countries, used with permission.

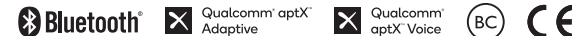

Made in China.

Snapdragon Sound and Qualcomm aptX are products of Qualcomm Technologies, Inc. and/or its subsidiaries. Qualcomm, Snapdragon and Snapdragon Sound are trademarks or registered trademarks of Qualcomm Incorporated. aptX is a trademark of Qualcomm Technologies International, Ltd., registered in the United States and other countries.

取得審驗證明之低功率射頻器材，非經核准，公司、商號或使用者均不得擅自變更頻率、加大功率或變更原設計之特性及功能。
低功率射頻器材之使用不得影響飛航安全及干擾合法通信；經發現有干擾現象時，應立即停用，並改善至無干擾時方得繼續使用。
前述合法通信，指依電信管理法規定作業之無線電通信。
低功率射頻器材須忍受合法通信或工業、科學及醫療用電波輻射性電機設備之干擾。



ARC II

Smart Open Ear True Wireless Headphone

User Manual