

SYGOLE

Operation Manual for High Frequency Integrated RFID Reader





Technical Manual

Integrated RFID Reader

The purpose of the practical manual is to provide the complete hardware appearance parameter, electric parameter, necessary schematic circuit diagram of the high frequency integrated reader and relevant notices for installation and operation. If needed, the reader hardware may be correspondingly modified according to the information provided in the manual in order to adapt to the application conditions of different industrial fields.

The manual mainly includes the following contents:

- Notice for reader application
- Functional description of the reader
- Reader installation guide
- Reader interface definition, appearance and electric parameter
- Supporting tag of the reader

If you have any unclear information in the manual or any inconsistency with practical situations, please contact with us.

Contact Information:

- Guangdong Sygole Intelligent Technology Co., Ltd.
- Telephone Number: +86-769-26627955
- Fax: +86-769-26621889

Specification for Marks in the Manual

Caution Mark



If there is a “Caution Mark” in the manual, it indicates that the user needs to pay attention during use. If the user fails to follow or ignores such information during use, the equipment may be directly or indirectly caused to have abnormal operation. Please be careful to read the content with such mark.

Table of Contents

1.	Brief Introduction.....	4
1.1	Brief introduction to the reader	4
1.2	Effective range of the manual	4
1.3	Revision history	4
2.	Safety Instruction	5
3.	Application planning for high frequency RFID reader	6
3.1	High frequency RFID application system.....	6
3.1.1	Read-write area and transmission window of the reader.....	6
3.1.3	Tag installation orientation and movement direction	7
3.1.4	Static and dynamic operations.....	9
3.2	Reader and tag data.....	10
3.2.1	Read distance of the reader	10
3.2.2	Single-time read-write limitation and read-write time of the reader	11
3.3	Installation instruction.....	12
3.3.1	Overview	12
3.3.2	Notice for installation in metallic environment.....	12
3.3.3	Notice for tag installation.....	15
3.3.4	Power supply and wiring requirments.....	16
4.	Reader	16
4.1	Product features.....	16
4.2	Definition of communication interface	17
4.3	Physical parameters of the reader.....	17
4.4	Electric parameters of the reader.....	18
4.5	SG-HR-I1	19
4.5.1	SG-HR-I1 machine size	19
4.5.2	SG-HR-I1 LED Definition	19
4.5.3	Minimum distance between SG-HR-I1 readers	20
5.	Reader-tag Corresponding Read Distance	20
6.	Networking Application.....	21
6.1	Field bus communication mode	21
6.2	Serial communication mode.....	22

1. Brief Introduction

1.1 Brief introduction to the reader

Sygole SG-HR-I1 reader is an integrated high frequency RFID read-write device, with the working frequency as 13.56MHz, and can meet ISO-15693 standard, and support RS-485, RS-232 and TCP (POE) communication. The shell thereof is made of high strength engineering plastics. This series reader has such features as reliable recognition and convenient distributed deployment. Reader is widely applied in such fields as home appliances, automobiles, 3C, new energy, aerospace, rail traffic, equipment and engineering machinery.

1.2 Effective range of the manual

The manual is effective for all SG-HR-I series readers described in the manual and delivered after August 2018

1.3 Revision history

Table 1.1 Manual Version Information

Version	Revision Date	Revision Reason
V1.0	2017.10.20	The first version
V1.1	2018.7.15	Add product system planing

2. Safety Instruction

The product conforms to CE, UL, EMC and FCC significant safety specification. If you have any query upon the installation environment, please contact with our service representative.



It is not allowed to modify or demount the product.
If the user violates the requirement, the wireless equipment approval, the CE approval and the manufacturer certification will be canceled.



The product can be only maintained by the personnel of our company.
Unauthorized unpacking operation or improper product maintenance may cause significant equipment damage or personal injury to users.

3. Application planning for high frequency RFID reader

3.1 High frequency RFID application system

3.1.1 Read-write area and transmission window of the reader

Reader can generate an induced magnetic field during normal operation, and the intensity of the induced magnetic field is reduced proportionally along with the distance from the reader antenna, namely: the further the antenna, the weaker the magnetic field intensity. The distribution of the magnetic field depends on the antenna structure and the geometrical shape of the reader. When the magnetic field intensity at the tag position can activate the tag, the reader can communicate with the tag; different tags have different magnetic field intensities for activating the tags; in other word, different tags have different critical distances.

1.  Transmission window;
2. S_m main working field;
3. S_n second working field;
4. S_c critical field;
5. S_g limit distance (maximum clear distance between upper surface of the reader and the transponder, at which the transmission can still function under normal conditions);

Fig. 3.1 shows SG-HR-II Transmission window and magnetic field intensity thereof:

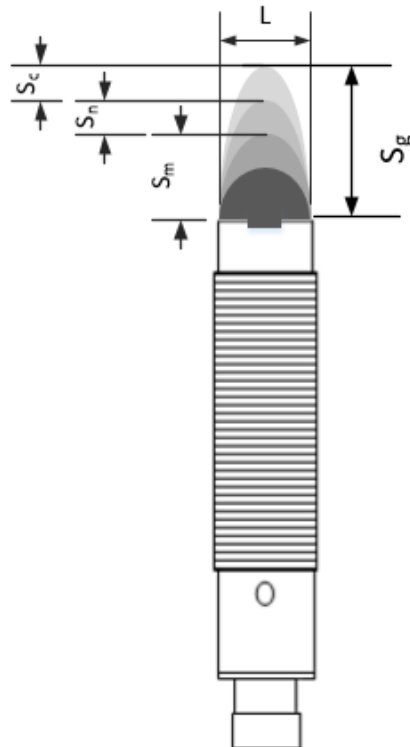

Fig. 3.1 SG-HR-II Transmission window and Front view

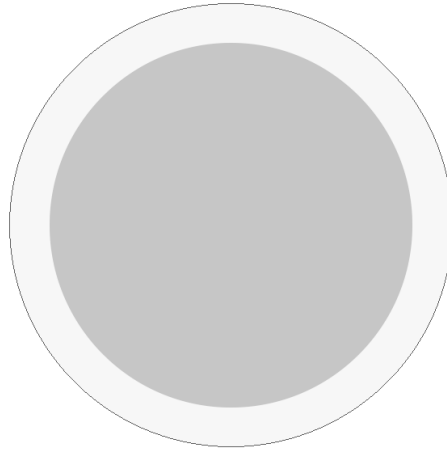



Fig. 3.2 SG-HR-11 Induction Plan View (as shown in shadow part)

- 
1. Transmission window;
 2. S_m main working field;
 3. S_n second working field;
 4. S_c critical field;
 5. S_g limit distance (maximum clear distance between upper surface of the reader and the transponder, at which the transmission can still function under normal conditions);

The induction area of the reader is divided into working area, critical area and non-working area. In practical application, the recommended working area is most stable for the reader. When a tag is located in the non-working area, the reader cannot have wireless communication with the tag. The critical area, located between the working area and the non-working area, has instable operation and can easily cause data error. When the reader runs in the metallic working environment, the working area will be weakened and the practical test shall prevail at this moment. The relation among the working areas of the reader is as shown in Tab. 3.1.

Tab. 3.1 Relation among Working Areas

Working Field	Main Working Field S_m	Second Working Field S_n	Critical Field S_c
Field Coverage	0~55% S_g	56~85% S_g	85~100% S_g

In practical application, the field communication may be influenced by various factors. Therefore, in order to ensure the reliability of RFID read-write operation, it is suggested to design the read-write distance of the RFID application system according to the recommended working Field .

Note: the division of the induction field is greatly related to the tag, and the purpose of above areas is to explain the application principle, and the practical measurement is required for specific implementation.

3.1.3 Tag installation orientation and movement direction

When the tag is parallel with the reader antenna, the tag can obtain the maximum energy from the magnetic field and better communicate with the reader, so the tag must be installed in parallel with the reader antenna, with the front face orientating to the reader.

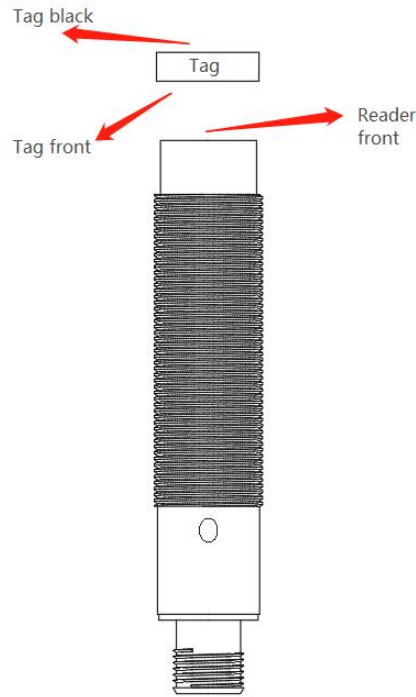

Fig. 3.3 Front View for Right Installation of Tag

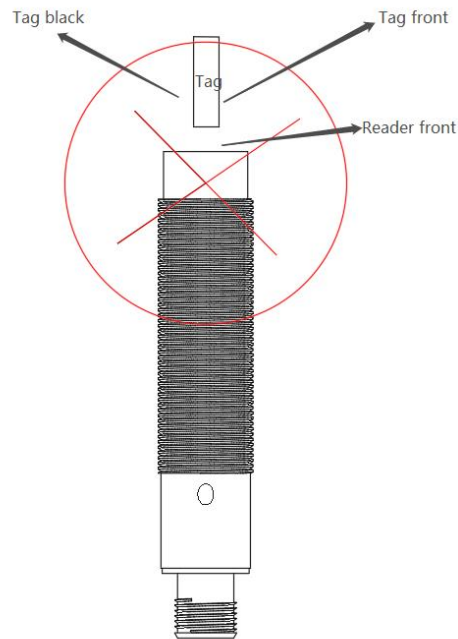

Fig. 3.4 Front View for Wrong Installation of Tag

Tag can enter the magnetic field area from any direction; in order to maximize the communication distance and obtain better quality, the tag should be installed maximally in parallel with the reader antenna. The following figure shows the entry of the tag into the transmission window from different directions:

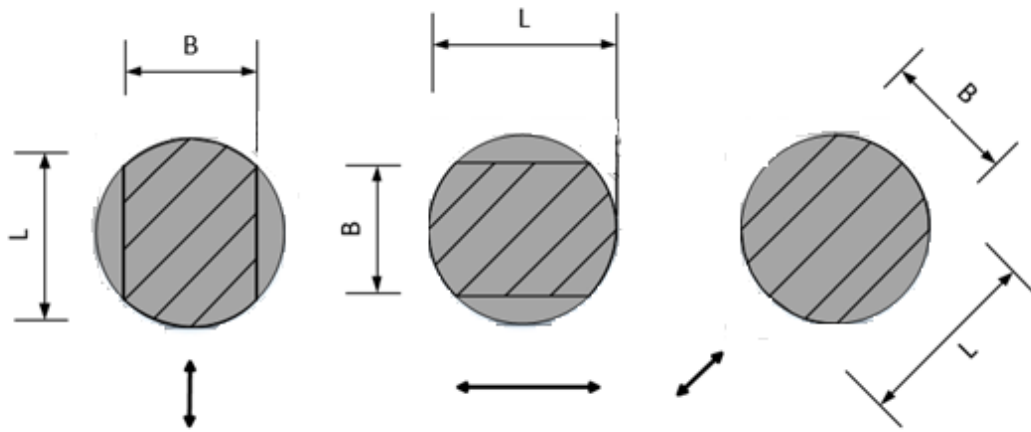
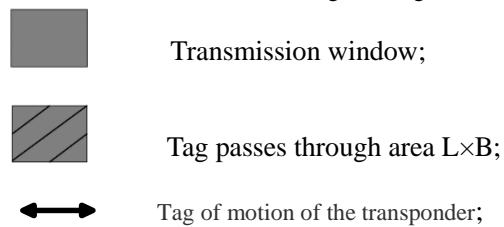

Fig. 3.5 Tag Movement Direction Diagram



3.1.4 Static and dynamic operations

3.1.4.1 Static mode

According to 3.1.1, the magnetic field area of the reader is divided into the recommended working area, the working area and the critical area. The operation in the critical area may cause unexpected results to the data. The reader can stably read relevant data in the working area in static environment, but in order to avoid the surrounding reflection influence, it is ideal to operate in the recommended working area.

Tab. 3.1 Critical Distance (S_g), Operation Distance and Transmission window Length Corresponding to Reader

Reader Model	Operation Distance	Critical Distance S _g	Transmission window Length L
SG- HR-I1	0~24 mm	30 mm (related to tag)	15 mm

3.2.2 Single-time read-write limitation and read-write time of the reader

The high frequency reader has the following limitation upon the read-write operation in the tag:

1. For single-command execution, the volume of the data read-write operation in the tag is as follows: the maximum data volume is 120 bytes.
2. For execution of multiple read-write commands, the next command can be executed only after a single command is executed and successfully responded.

Tag read-write time is determined by the following factors: tag memory type, read-write data volume, reader working mode and communication rate.

Reader has two working modes: interaction mode and automatic card-read mode (automatically read UID and automatically read tag memory). Under card-read mode, the reader RF is in working mode; when the tag is close to the transmission window, the tag will be automatically recognized; if the upper computer sends a command for tag read-write operation, the reader needs to firstly completely process the present automatic card-read operation and then execute the command sent by the upper computer.

The common tag memory type includes EEPROM and FRAM, and the reader takes different time to read and write the above two memory types. Two Sygole tags SG-HT-243(EEPROM) and SG-HT-244(FRAM) are taken as the example, when a tag is located in the read-write area and the automatic card-read function is unavailable, the time for read operation is as shown in the following table. The time listed in the table refers to the time difference between the time for the reader to receive the command request and the time for returning the response frame, and it is not related to the communication and the controller dispatching.

Read Bytes	Tag Model	
	SG-HT-243(EEPROM)	SG-HT-244(FRAM)
	Time Consumption (ms)	Time Consumption (ms)
8	28	28
16	31	31
32	37	36
64	55	56
112	85	86

If the data range read according to the command request is included in the automatic card-read data range, when the command request is received, the reader will directly access the data in the cache and respond to the command. If the automatic card-read function is configured and the data range read according to the command is inconsistent with the automatic card-read function, the reader will take the time for at most two card-read operations.

When a tag is located in the read area and the automatic card-read function is unavailable, the write time is as shown in the following table:

Write Bytes	Tag Model	
	SG-HT-243(EEPROM)	SG-HT-244(FRAM)
	Time Consumption (ms)	Time Consumption (ms)
8	41	35
16	63	36
32	106	52
64	193	85
112	323	135

Note: the time mentioned in above table refers to the experimental test data read at a time and is only for your reference. However, a certain additional time brought by 2-3 repeated tag read-write operations of the reader may probably appear in the field application. In addition, such time is also closely related to the communication transmission mode and the speed. The specific read-write time should follow the field test.

3.3 Installation instruction

3.3.1 Overview

RFID reader is operated on the basis of the magnetic field, so according to the magnetic field property, any metal near to the reader can influence the function of the reader. Therefore, please pay attention to the following contents during field installation:

1. When a tag is embedded into the metal, it is necessary to place the tag in parallel with or higher than the metal plane;
2. In metallic environment, please pay attention to the installation distance between the reader and the metal;
3. If a metal framework is installed with multiple readers, interference may be caused thereby;
4. Please pay attention to the minimum installation distance between two tags (please refer to the tag instruction for details);
5. Please pay attention to the minimum installation distance between two readers (please refer to the reader instruction for details);

3.3.2 Notice for installation in metallic environment

According the principle and characteristics of high frequency RFID, if a reader is installed on metal, the performance thereof will be influenced, so please pay attention to the following contents when the reader is installed in a metallic environment:

Installation on metal surface ---- it is necessary to reserve a buffer area (nonmetallic medium can be added in the buffer area)

Buffer area ---- it refers to the distance from the reader to the metal surface

1. Buffer area = 0 cm, namely: the reader is directly installed on the metal surface, and the read-write distance of the reader will be reduced by at least 10%; the specific data are related to metal material, size, thickness, etc.;
2. When a buffer area is more than or equal to 20 mm, the performance of the reader is approximate to that of the reader installed on a nonmetallic surface; **it is suggested to design the buffer area to be more than 20 mmduring installation.**

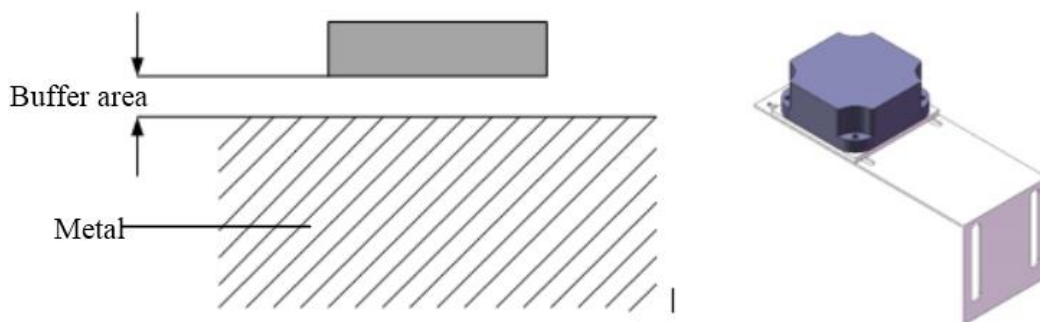

Fig.3.7 Demonstration for Nut Type Reader Installation in Metallic Environment

If the shell of the reader is made of metal, it is suggested to adopt a plastic support under the condition of poor ground connection, as shown in Fig. 3.8:

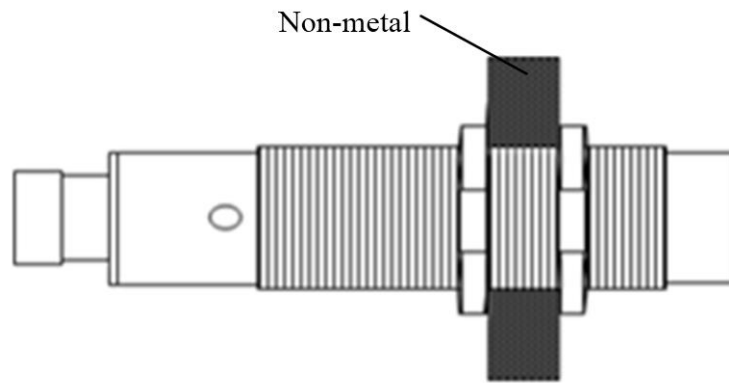

Fig. 3.8 Demonstration of Thread Type Reader Installation in Metallic Environment

Embedded installation into metal ---- it is necessary to reserve a free area large enough.

Free area ---- it refers to the metal blank area around the reader which is embedded into metal.

1. When A is equal to 0 cm, namely: when the reader head is not reserved with a free area during installation, the read-write distance of the reader will be severely reduced, so such installation mode is not recommended;

2. When A is equal to 10 cm, the actually measured read-write distance of the reader is averagely reduced by 10%; the specific data should follow the actual test in application;

In order to meet the read-write distance requirements, it is necessary to reserve a sufficient free area in practical application (*it is suggested to control A value to be not less than half of the reader length and width*);

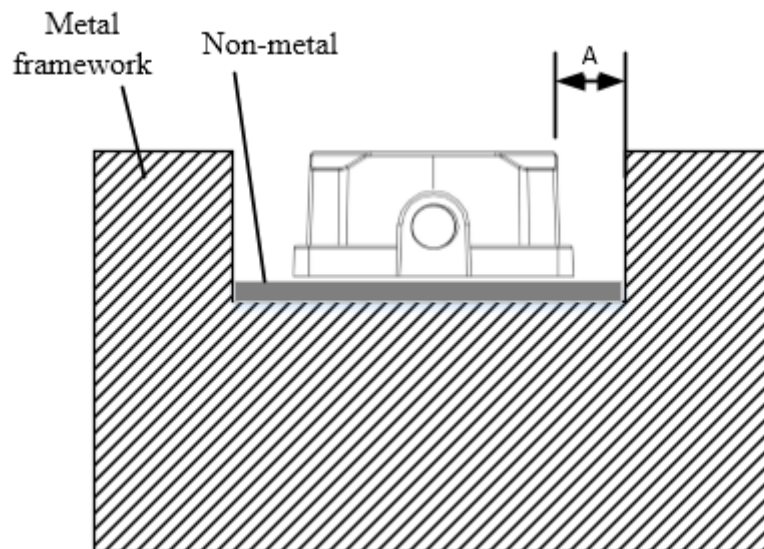

Fig. 3.9 Demonstration of Embedded Installation into Metal
Installation of reader into metal framework ---- please avoid conductor ring.

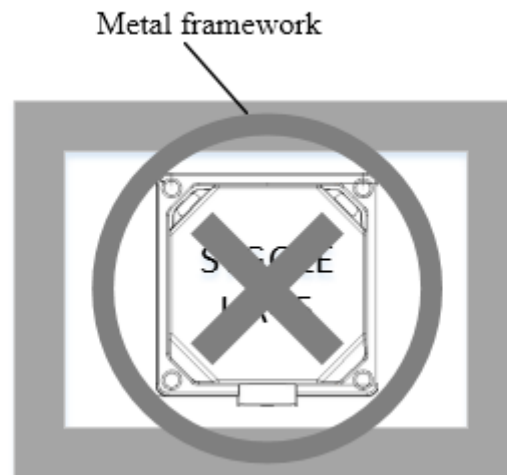

Fig. 3.10 Diagram for Annular Metal Framework Installation Mode

If a single reader has been installed and surrounded by an enclosed metal framework, the metal framework may absorb the induced current generated by the magnetic field of the reader. If the metal framework is closer to the reader, the interference becomes greater, so such installation mode should be avoided in practical application.

Installation of multiple readers in metal framework

The installation of multiple readers in an enclosed metal framework is as shown in Fig. 3.12, and interference may be generated among the readers, thus resulting in the reduction of the success rate of the communication between the reader and the tag; if above installation mode cannot be avoided, D distance must be more than 2,500 mm; or as shown in Fig. 3.13, a non-metallic distance piece more than 20 mm should be inserted between the reader and the metal framework;

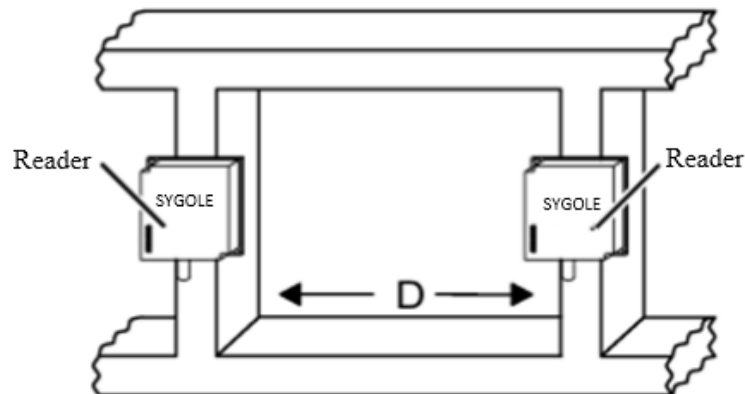

Fig. 3.11 Demonstration of Installation of Multiple Readers in Metal Framework

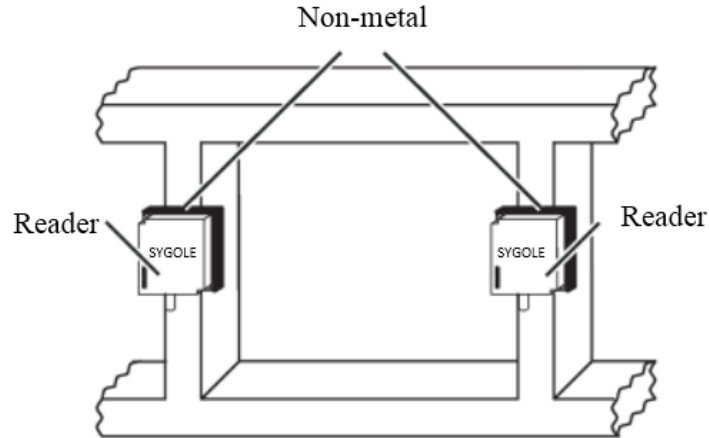

Fig. 3.12 Demonstration of Insertion of Non-metal between Reader and Metal Framework

3.3.3 Notice for tag installation

Tag includes two types ---- anti-metal tag and non-anti-metal tag. It is suggested to install non-anti-metal tag in a non-metallic environment; if a tag is inevitably installed in a metallic environment, please follow the regulations listed below:

Installation on metal surface ---- non-anti-metal tag should be reserved with a buffer area while anti-metal tag can be directly installed on metal surface.

Buffer area ---- it refers to the distance from the tag to the metal surface.

1. When a non-anti-metal tag is installed on metal surface and the buffer area is more than or equal to 20 mm, the performance of the tag may be reserved by more than 80%;
2. When an anti-metal tag is directly installed on metal surface, the original performance thereof can be also reserved by more than 90%.

Tag installation into metal ---- it is not suggested to embed a non-anti-metal tag into metal, and anti-metal tag can be directly embedded into metal.

Free area ---- it refers to the metal blank area around the tag which is embedded into the metal.

1. When an anti-metal tag is embedded into metal installation surface and is not reserved with a free area, the performance of the tag can be still reserved by more than 90%;
2. When a non-anti-metal tag is embedded into metal installation surface, a free area with size of $a \geq 2X$, $b \geq 2y$ and $c \geq 20$ mm must be reserved in order to reserve more than 80% of the original performance of the tag.

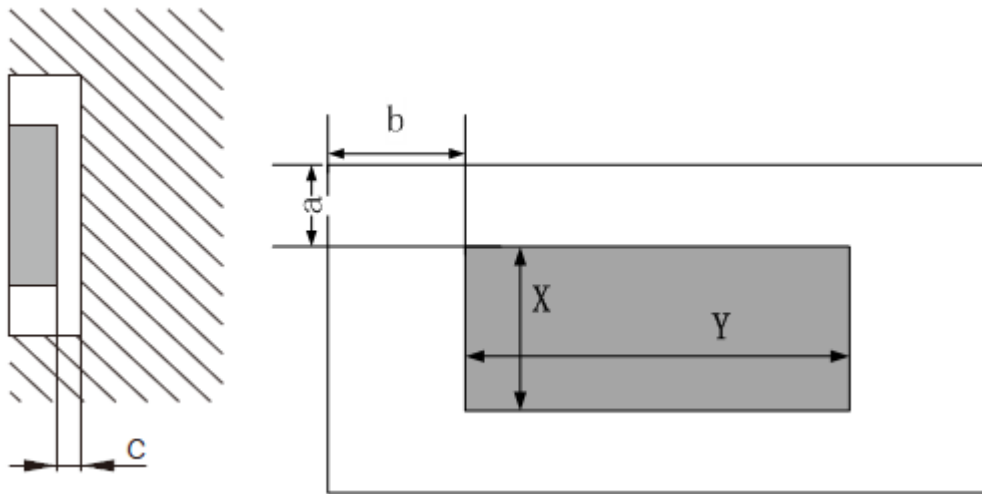

Fig. 3.13 Tag Installation Environment

3.3.4 Power supply and wiring requirements

3.3.4.1 Wiring requirements

In industrial environment, correct ground connection is the main method for noise suppression and interference prevention, and the main interference of the equipment circuit is sourced from the unreasonable ground wire. Therefore, it is import to correctly handle the ground connection of the circuit in order to ensure the normal operation and the read/write success rate of the reader.

Under normal circumstances, the power voltage of the reader equipment is 24V, belonging to the low voltage, so the power wire and 485 power wire of the reader should be connected to the weak current trunking during wiring, and the trunking must have standard ground connection (“0” electric potential). **If the trunking and the shielding layer cannot be connected to the standard “0” electric potential, the power supply should follow relevant regulation in 3.3.4.2.**

3.3.4.2 Power supply requirements

In industrial environment, electromagnetic interference has such characteristics as complexity, variability and uncontrollability and usually enters the reader through power supply coupling to generate adverse impact and cause abnormal operation of the reader, so power interference is one of the most harmful main interference sources. In order to eliminate such conduction interference, it is suggested to provide independent power supply or set a filter at the power terminal for RFID.

4. Reader

4.1 Product features

SG-HR-I series reader products have the features as shown in Tab. 4.1:

Tab. 4.1 SG-HR-I Series Reader Product Features

Reader	SG-HR-I1
Product Features	
Working frequency	13.56MHZ
Supported protocol	ISO15693
communication interface	RS485 RS232
Read-write distance	0~30 mm
Shell material	Nickel plated brass + ABS

The products with different communication interfaces have different order models. Specifically, the order model of each product is as shown in the following table:

Communication interface	RS232	RS485
Model		
SG-HR-I1	SG-HR-I1-RS232	SG-HR-I1-RS485

4.2 Definition of communication interface

SG-HR-I series products support RS485 and RS232 interfaces, wherein SG-HR-I5 products also support TCP (POE) interface, and the default interface is RS485 interface. Specifically, the interfaces are defined as follows:

Tab. 4.2 RS485 Interface (M12 Acoding 5pin male) Pin Definition

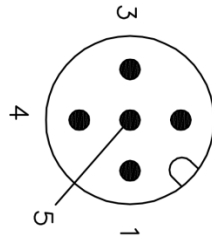
No.	Definition	Precast Cable Color	Self-provided Cable Requirement	Schematic Diagram (M12 Acoding 5pin male)
1	24V	Brown	4-core cable or 4-core shielded cable, with cable core at least 24AWG	
2	RS485_A	White		
3	0V	Blue		
4	RS485_B	Black		
5	PE	Shielding layer		

Tab. 4.3 RS232 Interface (M12 Acoding 8pin Male) Pin Definition

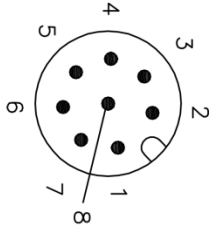
No.	Definition	Precast Cable Color	Self-provided Cable Requirement	Schematic Diagram (M12 Acoding 8pin male)
1	24V	Brown	6-core shielded cable, with cable core at least 24 AWG	
2	RX	White		
3	0V	Blue		
4	TX	Pink		
5	PE	Grey		
6	COM	Yellow		
7	NC	Green		
8	NC	Red		

4.3 Physical parameters of the reader

The physical parameters of SG-HR-I series readers are as shown in Tab. 4.5:

Tab. 4.5 Physical Parameters of SG-HR-I Series Readers

Reader	SG-HR-I1
Product Features	
Working temperature	-25°C ~ +70°C
Storage temperature	-25°C ~ +85°C
Working humidity	5% ~ 95%RH (no condensation)
Enclosure rating	IP67
Vibration resistance	GB/T 2423.10-2008/IEC 60068 -2 -6:1995
Surge impact interference immunity	GB/T 17618-1998 4.2.5, GB/T 17626.5-2008

Wireless radiation disturbance limit value	GB 9254-1998, GB/T 17626.3-1998
Power port conduction interference limit value	GB 9254-1998, GB/T 17626.3-1998
Static discharge interference immunity	GB/T 17618-1998 4.2.1, GB/T17626.2-1998
Certification	CE

4.4 Electric parameters of the reader

The electric parameters of SG-HR-I series readers are as shown in Tb. 4.6:

Tab. 4.6 Electric Parameters of SG-HR-I1 Readers

Reader Type	SG-HR-I1
Working voltage	18V~30V DC
Power consumption	<=1W
Radio frequency output power	23dBm
Working frequency	13.56MHZ
Protocol standard	ISO15693
communication interface	RS485/RS232
communication speed	RS232/RS485: default 115200

4.5 SG-HR-I1



4.5.1 SG-HR-I1 machine size

Tab. 4.7S G-HR-I1 Machine Size Parameter

Name	Parameter
Boundary dimension	φ18*92 mm
Total weight	<0.1KG
Fixation type	Nut fixation
Shell material	Nickel plated brass + ABS
Shell color	Silver + black

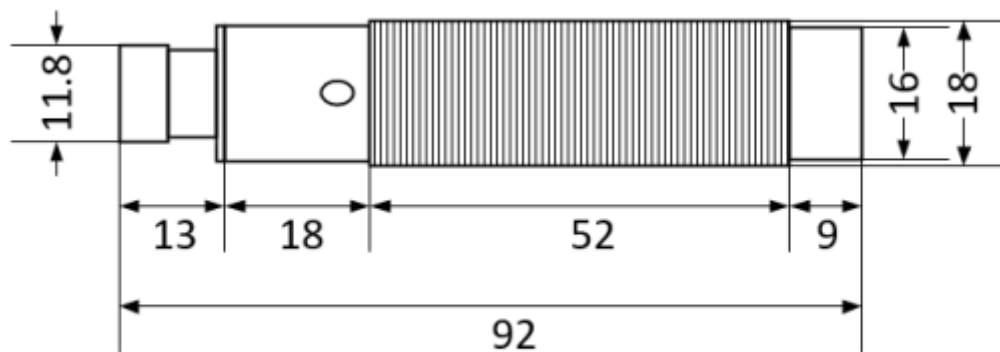

Fig. 4.1 G-HR-I1 Machine Size Diagram (Unit mm)

4.5.2 SG-HR-I1 LED Definition

SG-HR-I1 has one LED indicator light in total, and the specific definition is as follows:

Tab. 4.8 Name and Function Description for Indicator Light of SG-HR-I1 Reader

Name of Indicator	Specification
-------------------	---------------

Light

Power supply/communication indicator light	OFF: not electrified Normally-on green light: normal power supply Normally-on blue light: tag in the read area (automatic card-read status) Green light flicker: in communication
--	--

4.5.3 Minimum distance between SG-HR-I1 readers

The minimum distance of parallel installation of SG-HR-I1 readers should be more than or equal to 100 mm, as shown in Fig. 4.2.

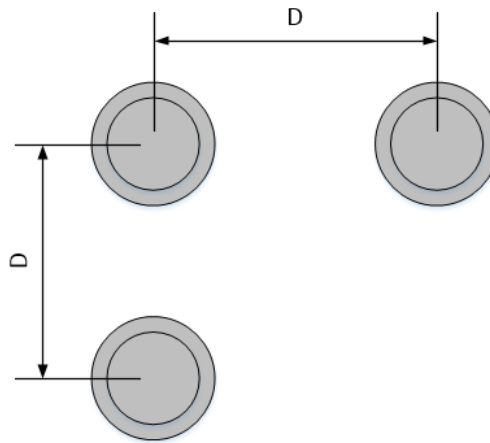

Fig. 4.2 Minimum Distance of Parallel Installation of SG-HR-I1 Readers

The minimum distance of face-to-face installation of SG-HR-I1 readers should be more than or equal to 100 mm, as shown in Fig. 4.3.

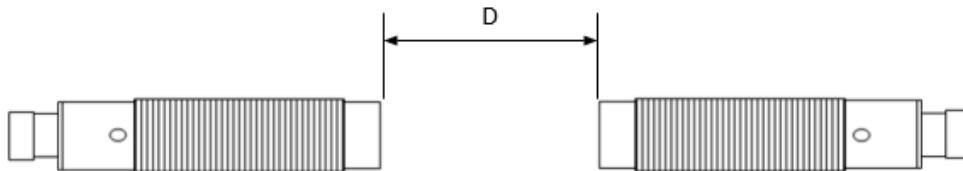

Fig. 4.3 Minimum Distance of Face-to-face Installation of SG-HR-I1 Readers

5. Reader-tag Corresponding Read Distance

For the same type of readers, the read/write distance is related to the corresponding tag, and the reader-tag corresponding read distance is as shown in Tab. 5.1.

Tab.5.1 Reader-tag Corresponding Read Distance

Read Distance	HR-I1
SG-HT-114M	7/10 mm
SG-HT-114M T	7 mm
SG-HT-133	40 mm

SG-HT-134	26 mm
SG-HT-143	33 mm
SG-HT-214M	7 mm
SG-HT-243	30 mm
SG-HT-243M	30 mm
SG-HT-244	--
SG-HT-263	--
SG-HT-263M	--
SG-HT-264	--
SG-HT-268	--
SG-HT-524M	16 mm

6. Networking Application

Sygole I series products support multiple communication modes. During networking application, the user may select a suitable communication mode according to the practical application conditions. Generally speaking, the hardware topology graph for application is as shown in the following figure:

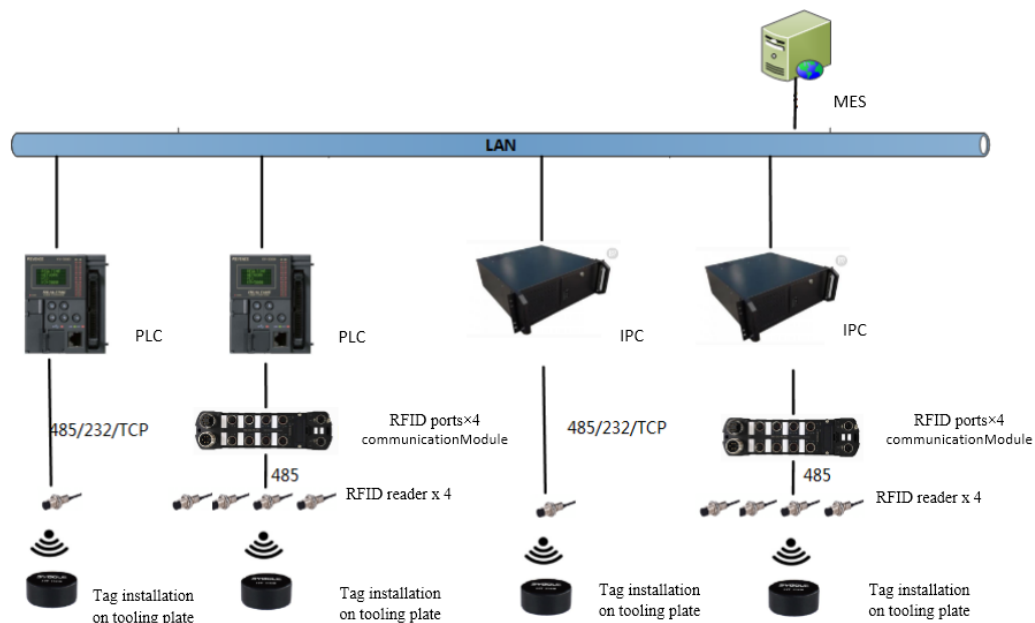

6.1 Field bus communication mode

In some cases, the field bus communication mode should be adopted to meet such application requirements for large amount of RFID reader heads and high data timeliness. Sygole I series products can support the field bus through gateway controller, and support such protocols as ProfiNet, EtherCAT, Ethernet/IP, DeviceNet, CCLINK and MODBUS TCP. Specifically, readers are connected to the gateways which are mutually connected in series. In this way, all readers can be connected to the same network. Specifically, the networking mode is as follows:

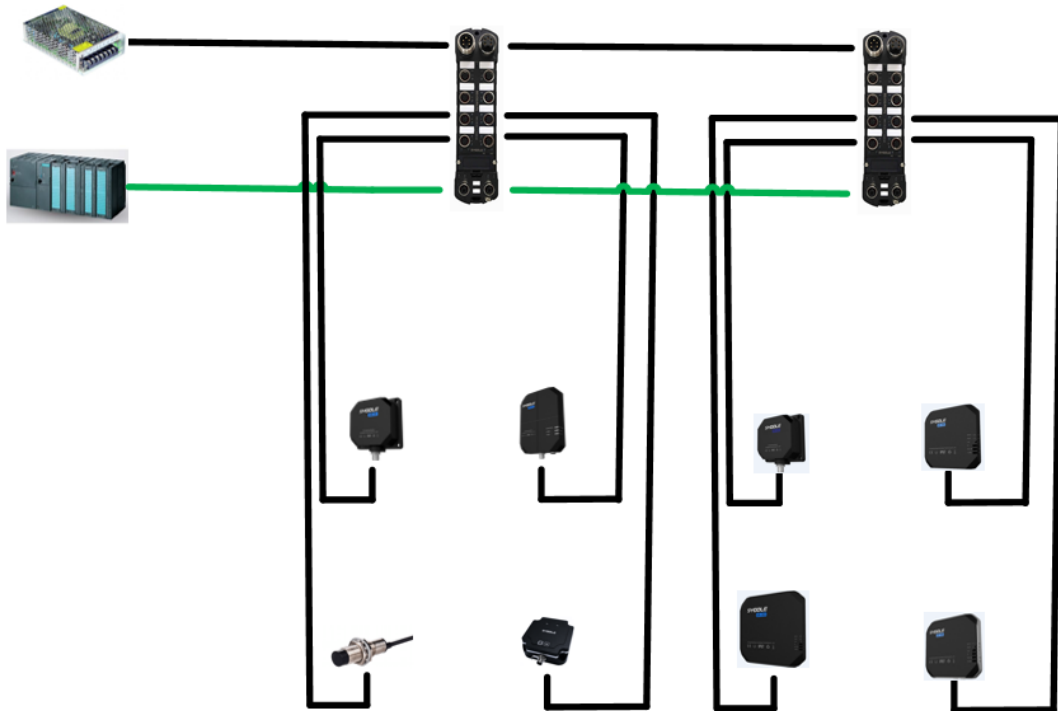

6.2 Serial communication mode

All Sygole high frequency products support RS232 and RS485 communication modes. Specifically, MODBUS RTU communication protocol can be used in serial communication. RS485 communication mode can be used for networking application, and in networking application, various readers need to work at different time. specifically, the networking mode of RS485 is as follows:

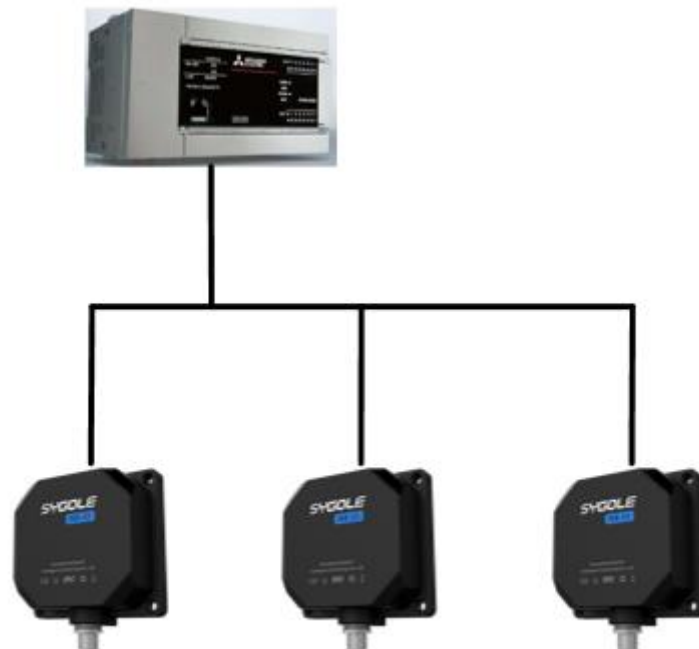

FCC NOTICE:

This equipment has been tested and found to comply with the limits for a Class B digital device, pursuant to Part 15 of the FCC Rules. These limits are designed to provide reasonable protection against harmful interference in a residential installation. This equipment generates, uses and can radiate radio frequency energy and, if not installed and used in accordance with the instructions, may cause harmful interference to radio communications. However, there is no guarantee that interference will not occur in a particular installation. If this equipment does cause harmful interference to radio or television reception, which can be determined by turning the equipment off and on, the user is encouraged to try to correct the interference by one or more of the following measures:

- Reorient or relocate the receiving antenna.
- Increase the separation between the equipment and receiver.
- Connect the equipment into an outlet on a circuit different from that to which the receiver is connected.
- Consult the dealer or an experienced radio/TV technician for help.

To assure continued operation, follow the attached installation instructions and use only shield cables when connecting to other devices. Changes or modifications not expressly approved by the party responsible for compliance could void the user's authority to operate the equipment.

This device complies with part 15 of the FCC Rules. Operation is subject to the following two conditions: (1) This device may not cause harmful interference, and (2) this device must accept any interference received, including interference that may cause undesired operation.

The equipment complies with FCC radiation exposure limits set forth for an uncontrolled environment. The equipment should be installed and operated with minimum distance 20cm between the radiator & your body.