

JAXJOX® Interactive Studio

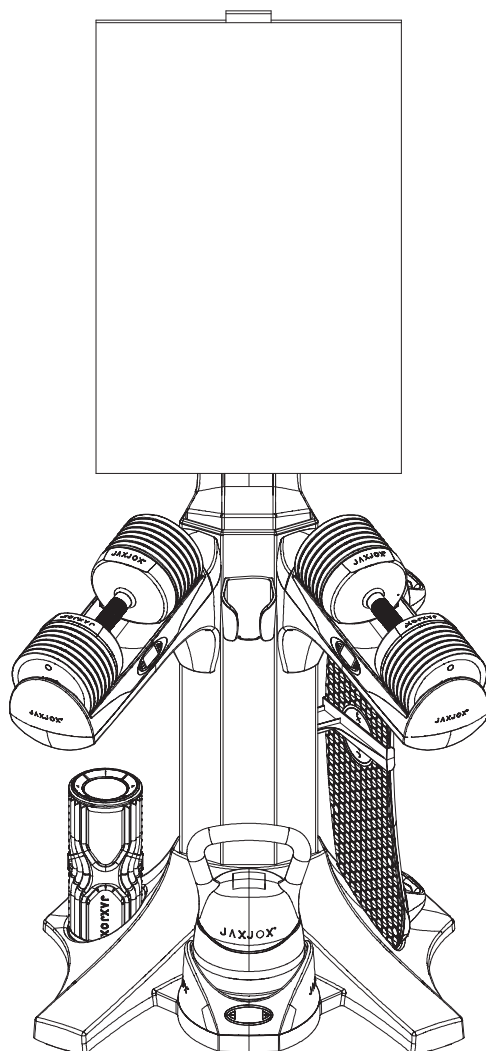

USER MANUAL

TABLE OF CONTENTS

Safety Warnings	1
Notices	2
Specification	3
Setting Up Your Interactive Studio	4
Assembly	4
Install The Interactive Studio Base And Main Stand	5
Install Dumbbell	6
Install Tv To The Stand	7
Install The Main Stand And Tv Stand	8
Install Push up Bar Holder	9
Plug In	9
Charging And Use Device	10
Maintenance And Care	14
Warranty	14

WARNING: To reduce your risk of injury, read all precautions and instructions in this manual before using this equipment. Improper use or maintenance can void the warranty. Keep this manual for future reference. Access the latest user manual, at jaxjox.com

SAFETY WARNINGS

The JAXJOX Interactive studio is very heavy – we recommend placing it on the floor to minimize the risk of injury.

Before starting your workout, ensure your environment is free of anything that may interfere with your movements.

When moving the device, dis-assemble all of the parts and reassemble them in the new location. Do not attempt to move the entire unit at one time.

Consult your physician before starting a workout plan. If you experience faintness, pain, or shortness of breath, stop exercising immediately, and consult a physician. Select a weight and perform a workout that is appropriate for your fitness level. Before exercising, please carefully evaluate your own state and do warmup exercises.

The studio is not a toy. Do not allow children or pets to play with or around the device. Supervise and provide instruction to anyone under the age of 18 using the device. Do not drop the kettlebell or use excessive force when using the kettlebell. Do not move the studio is for indoor use only. Avoid using it near water, or in high humidity areas such as a sauna or steam room.

Prior to cleaning, unplug the studio. To clean the device, use a dry or slightly damp cloth. Avoid using detergents. Avoid water coming in contact with the base, as it contains sensitive electronics.

Use only original parts from the manufacturer. Changes or modifications to this unit not expressly approved by JAXJOX could void the warranty.

Notices:

FCC STATEMENT

This device complies with Part 15 of the FCC Rules. Operation is subject to the following two conditions: (1) This device may not cause harmful interference, and (2) This device must accept any interference received, including interference that may cause undesired operation.

WARNING: Changes or modifications not expressly approved by the party responsible for compliance could void the user's authority to operate the equipment.

NOTE: This equipment has been tested and found to comply with the limits for a Class B digital device,

pursuant to Part 15 of the FCC Rules. These limits are designed to provide reasonable protection against harmful interference in a residential installation.

This equipment generates, uses and can radiate radio frequency energy and, if not installed and used in

accordance with the instructions, may cause harmful interference to radio communications. However, there is no guarantee that interference will not occur in a particular installation. If

this equipment does cause harmful interference to radio or television reception, which can be determined by turning the equipment off and on,

the user is encouraged to try to correct the interference by one or more of the following measures:

- Reorient or relocate the receiving antenna.
- Increase the separation between the equipment and receiver.
- Connect the equipment into an outlet on a circuit different from that to which the receiver is connected.
- Consult the dealer or an experienced radio/TV technician for help.

This equipment complies with FCC radiation exposure limits set forth for an uncontrolled environment. This equipment should be installed and operated with minimum distance 20cm between the radiator and your body.

Responsible Party (Contact for FCC matters only):

JAXJOX Inc.

8720 148th Ave NE Redmond,

WA 98052

USA

www.jaxjox.com/contact

Specifications:

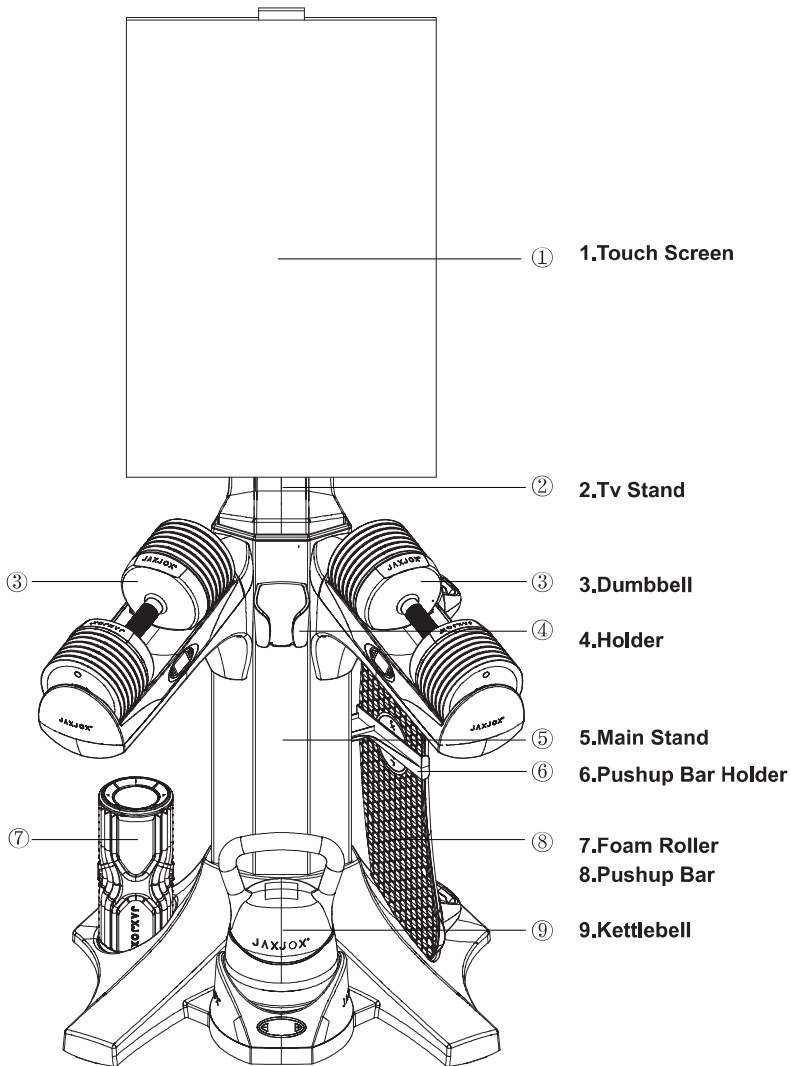

INTERACTIVE SPECIFICATIONS

Product Size: L980mmx W711mmx H1900mm

Power Consumption:

TV on: Max 100w

Chargeable port: Max 10W

Standby mode: Max 2.5W

TOUCHSCREEN SPECIFICATIONS

43" 4K Touchscreen

WIFI, Bluetooth4.2

32GB Memory





LED Backlight







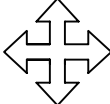
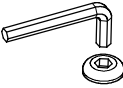



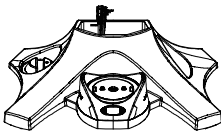



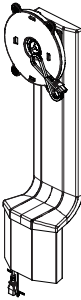

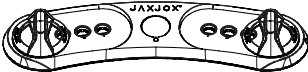
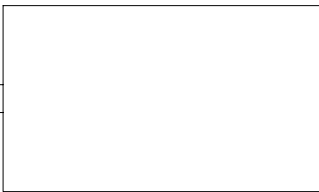

Setting Up Your Interactive Studio

LOCATION REQUIREMENTS.

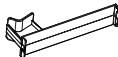
1. Place the equipment on a solid, level surface.
2. Use a mat to avoid damage the equipment and floor.
3. Do not use extension cords or adaptors. The included power cord must be able to reach an outlet

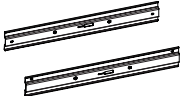
Assembly:

					
Tightening direction	Unscrew direction	+ Tightening - Unscrew	Adjust	Allen wrench	screwdriver

Main Base 1X 		Left Dumbbell Base 1X 		Right Dumbbell Base 1X 	
Main Stand 1X 	TV Stand 1X 	Dumbbell 2X 		Dumbbell Weight 2X 	
		Kettle Bell 1X 		Kettlebell Weight 1X 	
				Foam Roller 1X 	
		Pushup Bar 1X 			
Touch Screen 1X 		Waterbottle Holder 1X 	Pushup Bar Holder 1X 	Manual 1X 	
		TV Holder 1X 		Power Cord 1X 	
		Screw M5*15 4X 	Screw PWM6*25 4X 	Wrench M5 	

1.Install the interactive studio base and main stand.

1.1 Insert the plug according to the instruction, make sure the male and female plug connect well, not loosen.

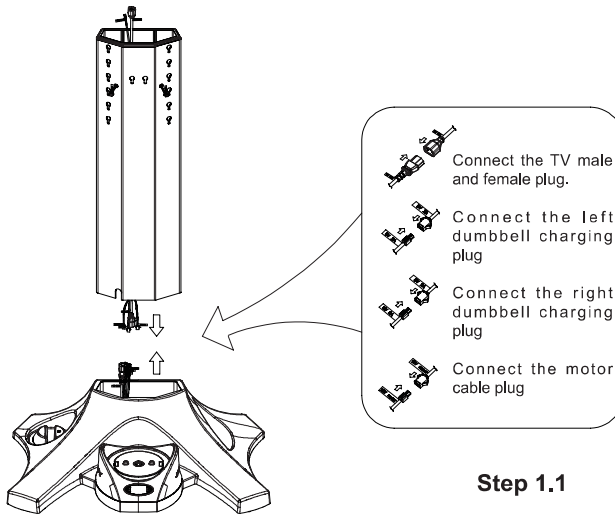

1.2 Put the notched end of the main stand down and insert into the main base.
Note: Do not rush the cable at the bottom of the main stand.

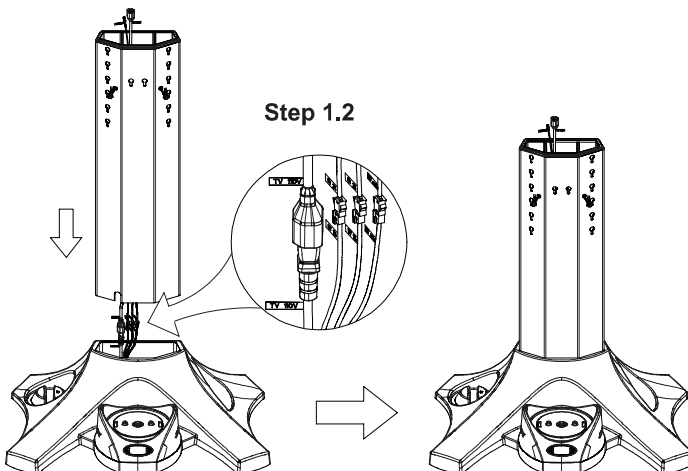

2. Install Dumbbell.

2.1.1 Assemble the left dumbbell. Connect the charging plug, make sure the male and female plug connect well, not loosen.

2.1.2: Hang the left dumbbell base into the gourd hole on the top of main stand. Note: Do not crush the cable.

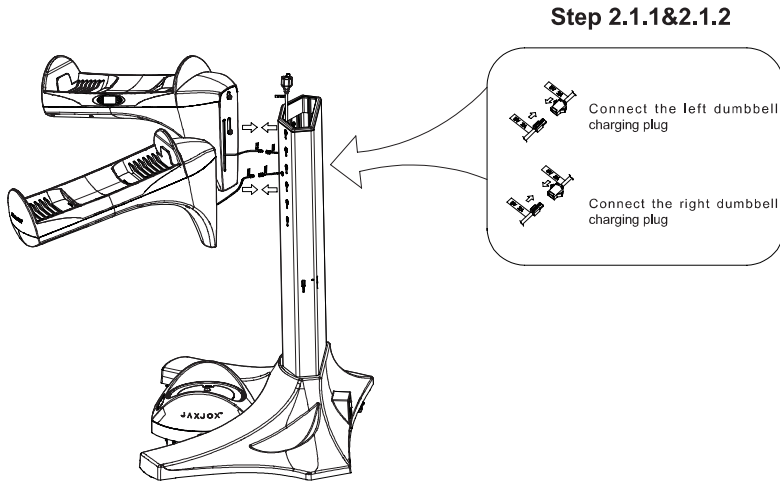

2.2.1 Install the right dumbbell. Connect the charging plug, make sure the male and female plug connect well, not loosen.

2.2.2 Hang the right dumbbell base into the gourd hole on the top of main stand. Note: Do not crush the cable.

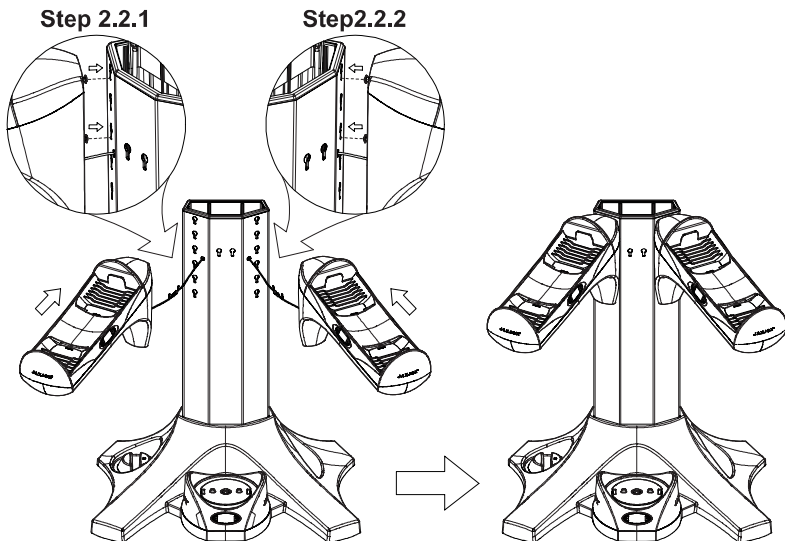

3. Install TV to the stand.

3.1 Install the TV holder.

Using 4 screws(PWM6*25) to fix the TV upper and lower holder with wrench, lock the screw. Note: Protect the TV camera and avoid damage to the TV during installation.

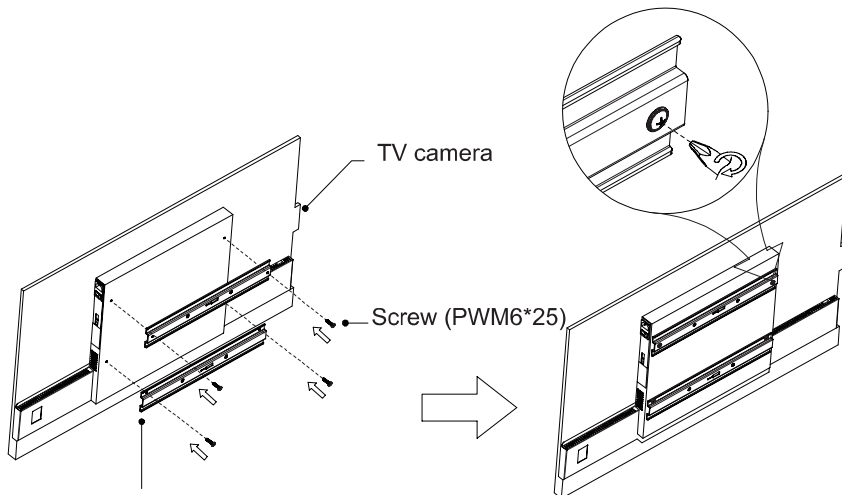

Step 3.1

3.2 Install the TV stand.

Using 4 screws(PM5*10) to fix the turntable, lack the screw.

3.3 Plug the TV power cord into the power jack at the side of TV.

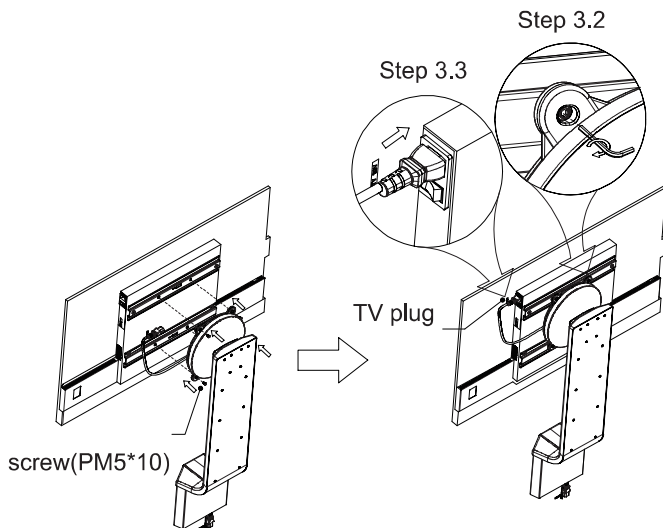

4. Install the main stand and TV stand.

4.1 Connect the TV and motor plug, make sure the male and female plug connect well, not loosen.

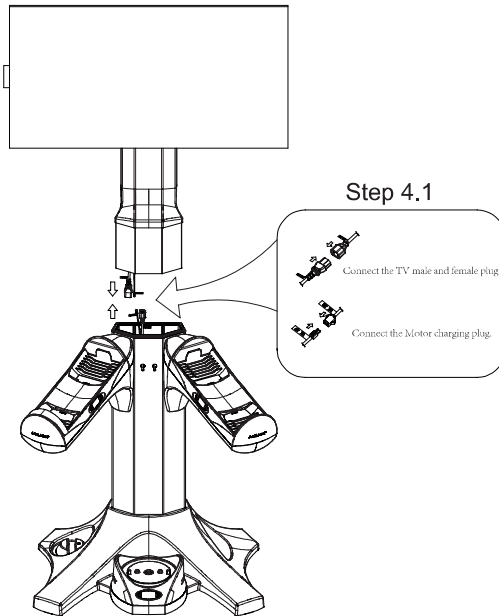

4.2 Put the TV stand into the main stand. Note: Do not crush the cable.

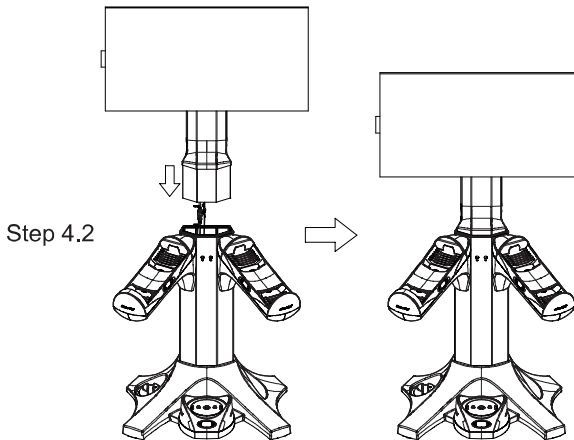

5. Install Push up Bar Holder

5.1 Put the push up bar holder into the gourd hole on the main stand

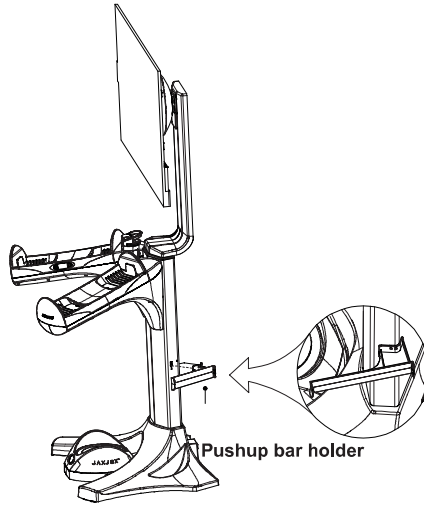

Step 5.1

6. Plug In.

6.1 After installation, check all the components are ready, plug the power cord into the power jack at the bottom of the base.

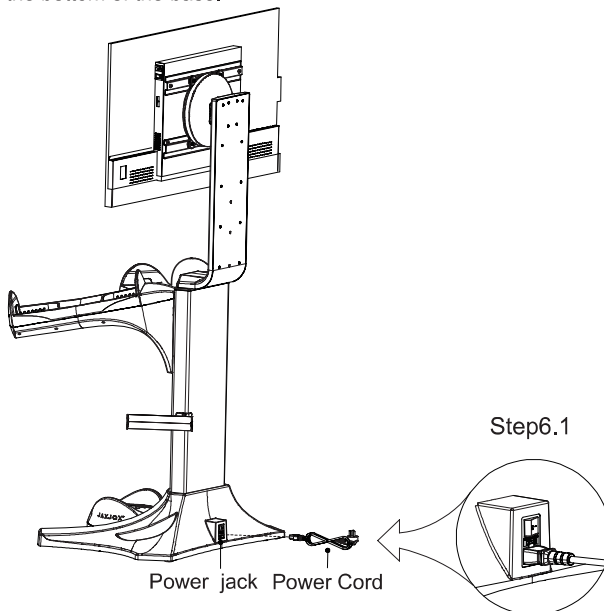

Step6.1