



Ra-01 SPECIFICATION

Version V1.1

Copyright ©2020

Disclaimer and copyright notice

The information in this article, including the URL address for reference, is subject to change without notice.

The document is provided "as is" without any guarantee responsibility, including any guarantee for marketability, suitability for a specific purpose, or non-infringement, and any guarantee mentioned elsewhere in any proposal, specification or sample. This document does not take any responsibility, including the responsibility for infringement of any patent rights caused by using the information in this document. This document does not grant any license for the use of intellectual property rights by estoppel or other means, whether express or implied.

The test data obtained in the article are all obtained from Anxinke's laboratory tests, and the actual results may vary slightly.

All brand names, trademarks and registered trademarks mentioned in this article are the property of their respective owners, and it is hereby declared.

The final interpretation right belongs to Shenzhen Anxinke Technology Co., Ltd.

Notice

Due to product version upgrades or other reasons, the contents of this manual may change. Shenzhen Anxinke Technology Co., Ltd. reserves the right to modify the contents of this manual without any notice or prompt. This manual is only used as a guide. Shenzhen Anxinke Technology Co., Ltd. makes every effort to provide accurate information in this manual. However, Shenzhen Anxinke Technology Co., Ltd. does not guarantee that the contents of the manual are completely free from errors. All statements and information in this manual And suggestions do not constitute any express or implied guarantee.

PRODUCT DESCRIPTION

Anxinke LoRa series modules (Ra-01S) are designed and developed by Anxinke Technology. This module is used for ultra-long-distance spread-spectrum communication. Its radio chip SX1268 mainly uses LoRa™ remote modem for ultra-long-distance spread-spectrum communication. It has strong anti-interference and can minimize current consumption. With SEMTECH's LoRa™ patented modulation technology, SX1268 has a high sensitivity of over -148dBm, a power output of +22dBm, a long transmission distance and high reliability. At the same time, compared to traditional modulation technology, LoRa™ modulation technology also has obvious advantages in anti-blocking and selection, which solves the problem of distance, anti-interference and power consumption that traditional design solutions cannot simultaneously take into account.

Application areas are used in automatic meter reading, home building automation, security systems, and remote irrigation systems.

Features

- LoRa™ modem
- Support FSK, GFSK, MSK, GMSK, LoRa™ and OOK modulation methods
- Support frequency band 411MHz~525MHz
- Working voltage is 3.3V, maximum output is +22dBm, maximum working current is 140mA
- Low power consumption characteristics in receiving state, the minimum receiving current is 4.5 mA, standby current is 1.6mA
- High sensitivity: as low as -140dBm
- Small volume dual row stamp hole patch package
- The module adopts SPI interface, half-duplex communication, with CRC, up to 256-byte packet engine

Main parameters

List 1 Main parameter description

Model	Ra-01S
Package	SMD16
Size	17*16*3.2(±0.2)MM
Antenna	Compatible with half-hole pads/through-hole pads (need to solder the antenna)/IPEX socket
Spectrum range	411MHz~525MHz
Operating temperature	-40 °C ~ 85 °C
Storage environment	-40 °C ~ 125 °C , < 90%RH
Power supply	2.7~3.6V, default 3.3V, current > 200mA
Interface	SPI
Programmable bit rate	Up to 300kbps
Certificate	/

一、 ELECTRICAL PARAMETERS

Ra-01S series modules are electrostatic sensitive devices, special precautions need to be taken when handling



prompt:

The Ra-01S module is an electrostatic sensitive device (ESD), which requires special ESD precautions, and should usually be applied to ESD sensitive components. The correct ESD handling and packaging procedures must be adopted during the entire handling, transportation and

operation of any application combined with the Ra-01S module. Do not touch the module with your hands or use a non-antistatic soldering iron for soldering to avoid damage to the module.

Electrical characteristics

Parameter	Name	Min	Typical	Max	Unit
Working temperature	TOPR	-40	25	85	°C
Voltage	VDD	2.7	3.3	3.6	V

Digital port characteristics

Description		Typical		Unit	
Working frequency		411~525		MHz	
Port	Name	Min	Typical	Max	Unit
IO level	VIO	2.7	3.3	3.6	V
Input logic level is low	VIL	-	-	0.2	V
Input logic level is high	VIH	0.8	-	-	V
Output logic level is low	VOL	-	-	0.1	V
Output logic level is high	VOH	0.9	-	-	V

·SPI Interface characteristics

symbol	Description	Condition	Mix	Typical	Max	Unit
Fsck	SCK frequency	-	-	-	10	MH Z
tch	SCK high time	-	50	-	-	ns
tcl	SCK low time	-	50	-	-	ns
trise	SCK rise time	-	-	5	-	ns
tfall	SCK fall time	-	-	5	-	ns
tsetup	MOSI establishment time	From MOSI change to SCK rising edge	30	-	-	ns
thold	MOSI maintenance time	Change from rising edge of SCK to MOSI	20	-	-	ns
tnsetup	NSS establishment time	From NSS falling edge to SCK rising edge	30	-	-	ns
tnhold	NSS maintenance time	From SCK falling edge to NSS rising edge, normal mode	100	-	-	ns
tnhigh	NSS high time between spi visits	-	20	-	-	ns
T_DAT A	DATA maintenance and establishment time	-	250	-	-	ns

二、 DIMENSION

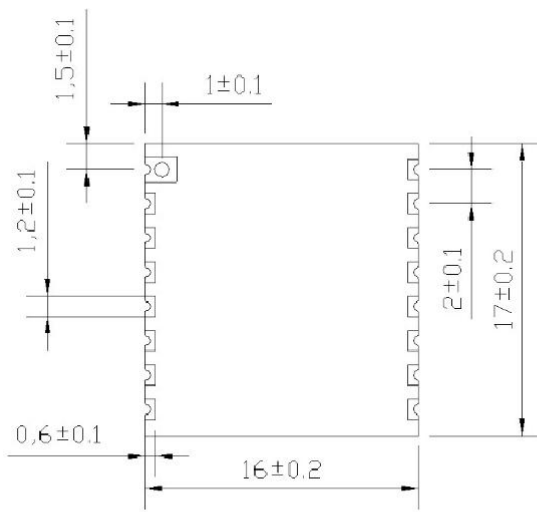
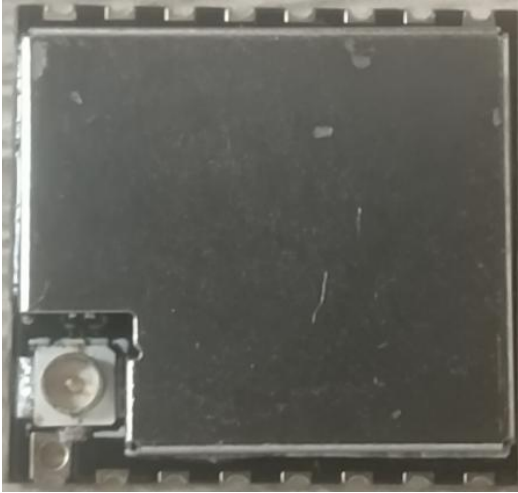

正面

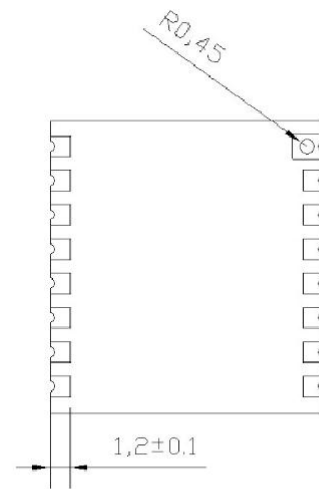

背面

三、 PIN DEFINITION

The Ra-01S module has a total of 16 interfaces. As shown in the pin diagram, the pin function definition table is the interface definition.



Ra-01S Pin diagram

PIN function definition

No.	Name	Function description
1	ANT	Connect the antenna
2	GND	Ground
3	3.3V	Typical 3.3V power supply
4	RESET	Reset
5	TXEN	RF control port
6	DIO1	Digital IO1 software configuration
7	DIO2	Digital IO2 software configuration
8	DIO3	Digital IO3 software configuration
9	GND	Ground
10	BUSY	Status indicator
11	RXEN	RF control port
12	SCK	SPI clock input
13	MISO	SPI data output
14	MOSI	SPI data input
15	NSS	SPI chip select input
16	GND	Ground

The 3 general-purpose IO pins of SX1268 are available in LoRa™ mode. Their mapping relationship depends on the configuration of the two registers RegDioMapping1 and RegDioMapping2.

operating mode	DIOx Mapping	DIO 3	DIO2	DIO1
All	00	Cad Done	Fhss Change Channel	RxRimout
	01	Valid Header	Fhss Change Channel	Fhss Change Channel
	10	Payload Crc Error	Fhss Change Channel	CadDetected
	11	-	-	-

四、SCHEMATIC DIAGRAM

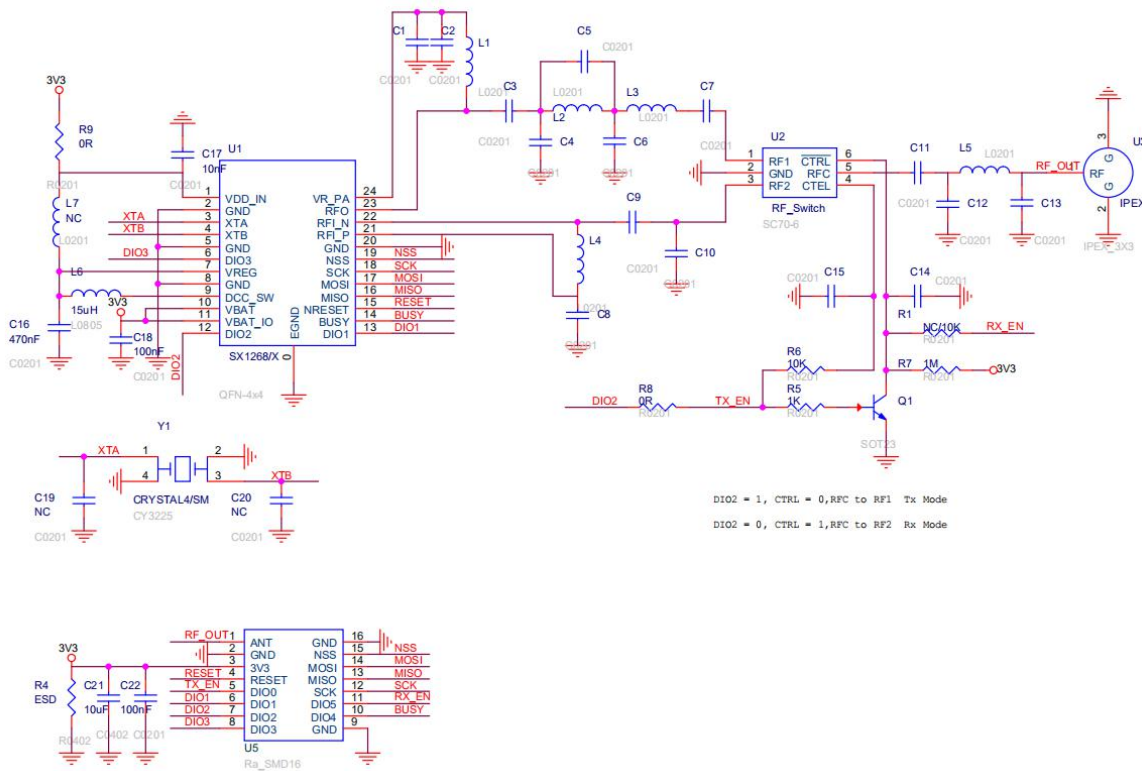

五、DESIGN GUIDE

1、Application circuit

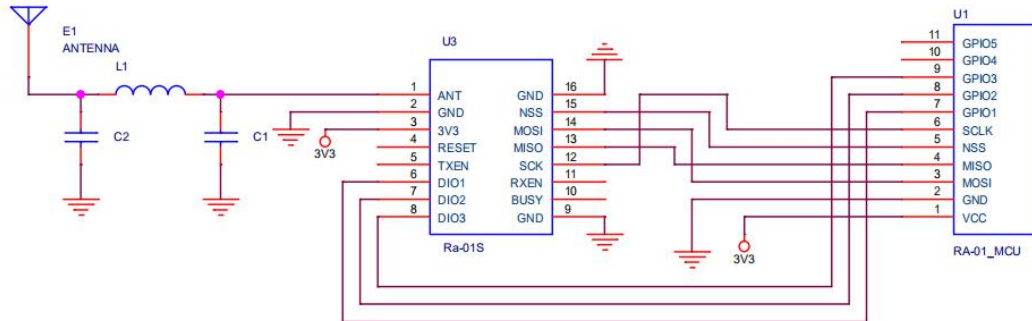

2、Recommended module package design size

Note: This is the Ra-01S module package drawing. It is recommended to design the PCB board according to this drawing so that the module can work normally on the PCB board; and when designing the pads, pay attention to the design of the pads on the PCB. The group corresponding to the pad shrinks and offsets, and the PCB pad expands from the module pad without affecting the use of the module.

3、Antenna installation

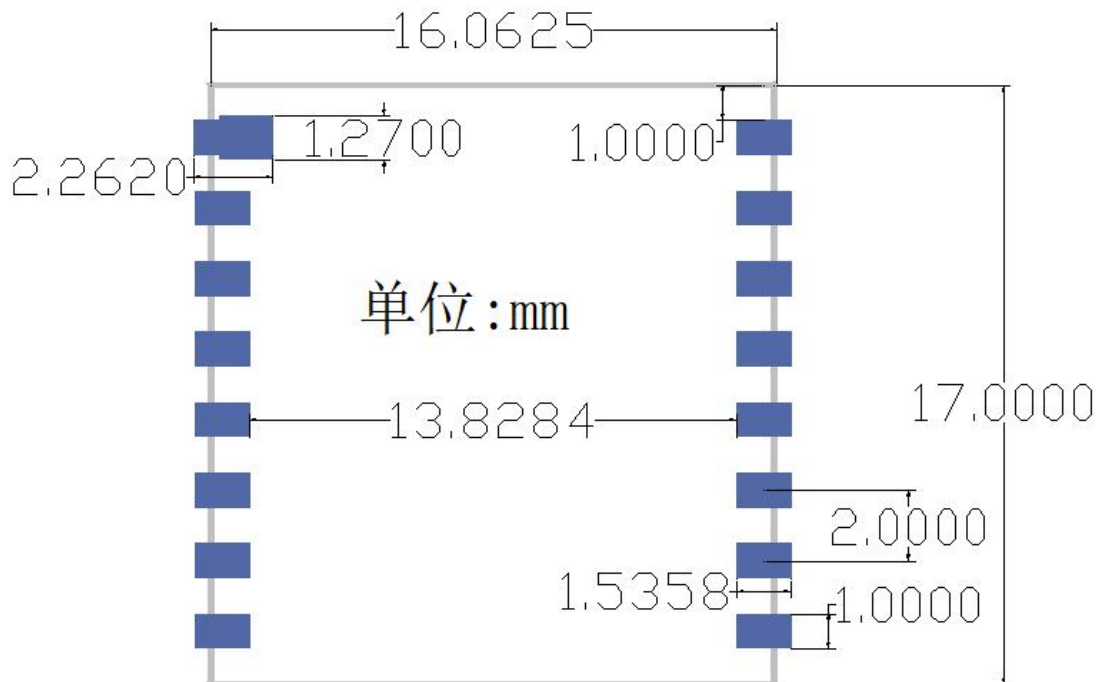

(1)、Ra-01S needs to be used for soldering antennas, and the module is compatible with half-hole pads and round-hole pads.

(2)、In order to achieve the best effect of the antenna, the antenna assembly location should be far away from the metal parts.

4、Power supply

(1)、Recommended 3.3V voltage, peak current recommended above 200mA

(2)、It is recommended to use LDO for power supply; if DC-DC is used, the ripple is recommended to be controlled within 30mV.

(3)、It is recommended to reserve the position of the dynamic response capacitor for the DC-DC power supply circuit, which can optimize the output ripple when the load changes greatly.

(4)、It is recommended to add ESD devices to the 3.3V power interface. .

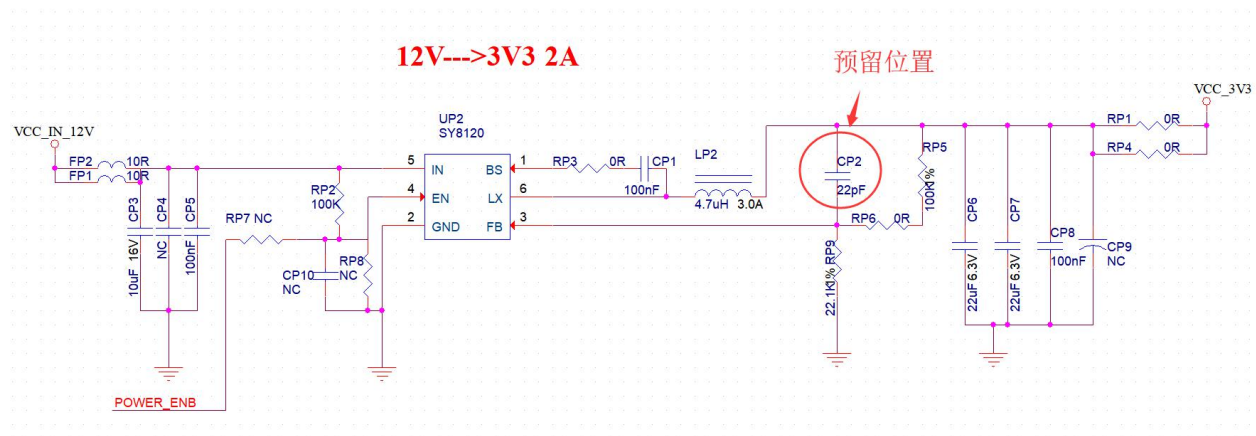

5、 Use of GPIO port

(1)、 There are some GPIO ports on the periphery of the module. If you need to use it, it is recommended to connect a 10-100 ohm resistor in series with the IO port. This can suppress overshoot and make the levels on both sides more stable. It is helpful for EMI and ESD.

(2)、 For the pull-up and pull-down of special IO ports, please refer to the instructions in the specification, which will affect the startup configuration of the module.

(3)、 The IO port of the module is 3.3V. If the main control and the IO level of the module do not match, a level conversion circuit needs to be added.

(4)、 If the IO port is directly connected to a peripheral interface or terminal such as a header, it is recommended to reserve an ESD device near the terminal of the IO trace.

Image Level conversion circuit

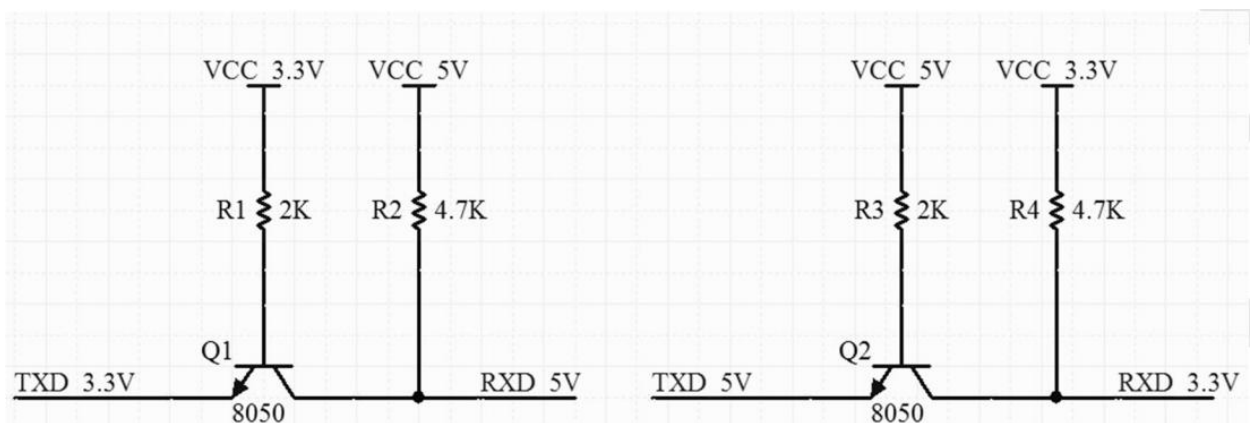

REFLOW SOLDERING CURVE

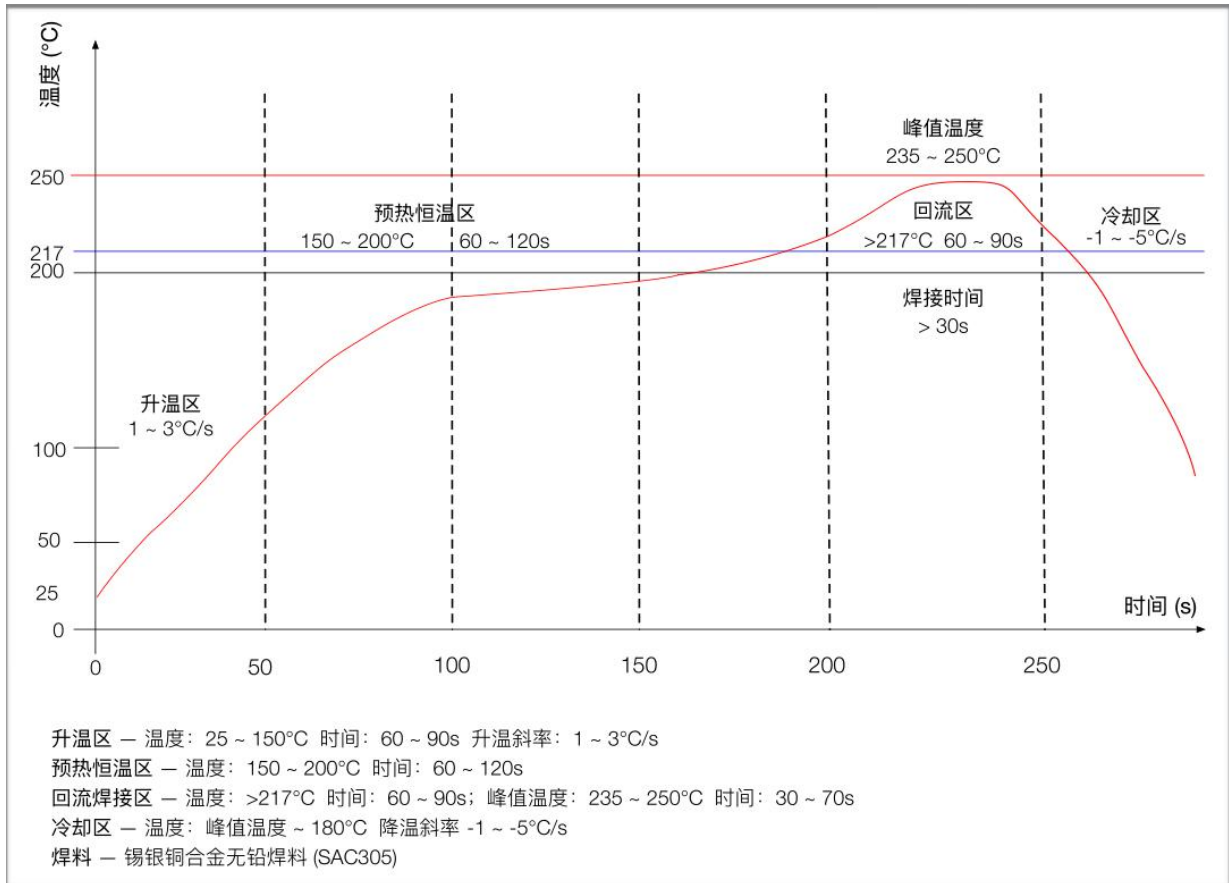

六、 PACKAGE

As shown below, the packaging of Ra-01S is braid.



七、 CONTACT US

Website: <https://www.ai-thinker.com>

Development DOCS: <https://docs.ai-thinker.com>

Forun: <http://bbs.ai-thinker.com>

Sample purchase: <https://anxinke.taobao.com>

Business: sales@aithinker.com

Technical support: support@aithinker.com

Address: 410, Block C, Huafeng Smart Innovation Port,

Gushu 2nd Road, Xixiang, Baoan District, Shenzhen

Tel: 0755-29162996

Copyright © 2020 Shenzhen Ai-Thinker Technology Co., Ltd All Rights Reserved



Integration instructions for host product manufacturers according to KDB 996369 D03 OEM Manual v01

2.2 List of applicable FCC rules

The Ra-01S is an LoRa Module with digitally modulated systems using an LoRa/FSK/OOK modulation. It operates on the 411-525MHz band and, therefore, is within U.S. FCC part 15.231 standard

2.3 Specific operational use conditions

The EUT is a LoRa Module

Operation Frequency: 411-525MHz

Modulation Type: LoRa/FSK/OOK

Number Of Channel: 115CH

Antenna Designation: Spring Antenna

Antenna Gain: 3.0dBi

Ai-Thinker lora Series Module (Ra-01S) designed and developed by Ai-Thinker .This module is used for long distance spread spectrum communication. Its RF chip ASR6501 (as show as figure 1) Mainly used LoRa™ remote modem, for ultra-long-distance spread spectrum communication, strong anti-interference, can minimize current consumption. With the help of the SEMTECH the patent technology of LoRa™, ASR6501 with -137dBm high sensitive, long range transmission, high reliability. Meantime, relative traditional modulation technique, LoRa™ modulation technique has obvious advantages in anti-blocking and selection, It solves the problem that traditional design scheme cannot consider distance, anti-interference and power consumption simultaneously. Its application can be automatic meter reading, home building automation, security system, remote irrigation system.

2.4 Limited module procedures

not applicable; Single Modular Approval Request

2.5 Trace antenna designs

Not applicable;

2.6 RF exposure considerations

To maintain compliance with FCC's RF Exposure guidelines, This equipment should be installed and operated with minimum distance between 20cm the radiator your body: Use only the supplied antenna.

2.7 Antennas

The Ra-01S is an LoRa Module beams signals and communicates with its antenna, which is Spring Antenna. The Spring Antenna gain is 3.0dBi. Antenna could not be in no-load state when module is working. During debugging, it is suggested to add 50 ohms load to the antenna port to avoid damage or performance degradation of the module under long-time no-load condition.

2.8 Label and compliance information

The final end product must be label in a visible area with the following

Host must Contains FCC ID: 2ATPO-RA-01S. If the size of the end product is larger than 8x10cm, then the following FCC part 15.19 statement has to also be available on the label: This device complies with Part 15 of FCC rules. Operation is subject to the following two conditions:

- (1) this device may not cause harmful interference and
- (2) this device must accept any interference received, including interference that may cause undesired operation.

2.9 Information on test modes and additional testing requirements

Data transfer module demo board can control the EUT work in RF test mode at specified test channel.

2.10 Additional testing, Part 15 Subpart B disclaimer

The module without unintentional-radiator digital circuit, so the module does not required an evaluation by FCC Part 15 Subpart B. The host should be evaluated by the FCC Subpart B.

ATTENTION

This device is intended only for OEM integrators under the following conditions:

- 1) The antenna must be installed such that 20 cm is maintained between the antenna and users, and
- 2) This device and its antenna(s) must not be co - located with any other transmitters except in accordance with FCC multi - transmitter product procedures. Referring to the multi - transmitter policy, multiple transmitter(s) and module(s) can be operated simultaneously without C2P.
- 3) For all products market in US, OEM has to limit the Operating Frequency: 411-525MHz by supplied firmware programming tool. OEM shall not supply any tool or info to the end - user regarding to Regulatory Domain change.

USERS MANUAL OF THE END PRODUCT:

In the user manual of the end product, the end user has to be informed to keep at least 20cm separation with the antenna while this end product is installed and operated. The end user has to be informed that the FCC radio - frequency exposure guidelines for an uncontrolled environment can be satisfied. The end user has to also be informed that any changes or modifications not expressly approved by the manufacturer could void the user's authority to operate this equipment.

If the size of the end product is smaller than 8x10cm, then additional FCC part 15.19 statement is required to be available in the users manual: This device complies with Part 15 of FCC rules.

Operation is subject to the following two conditions:

- (1) this device may not cause harmful interference and
- (2) this device must accept any interference received, including interference that may cause undesired operation.

FCC WARNING

This device complies with part 15 of the FCC Rules. Operation is subject to the following two conditions:

Any changes or modifications not expressly approved by the party responsible for compliance could void the user's authority to operate the equipment.

NOTE: This equipment has been tested and found to comply with the limits for a Class B digital device, pursuant to Part 15 of the FCC Rules. These limits are designed to provide reasonable protection against harmful interference in a residential installation. This equipment generate, uses and can radiate radio frequency energy and, if not installed and used in accordance with the instructions, may cause harmful interference to radio communications. However, there is no guarantee that interference will not occur in a particular installation.

If this equipment does cause harmful interference to radio or television reception, which can be determined by turning the equipment off and on, the user is encouraged to try to correct the interference by one or more of the following measures:

- Reorient or relocate the receiving antenna.
- Increase the separation between the equipment and receiver.
- Connect the equipment into an outlet on a circuit different from that to which the receiver is connected.
- Consult the dealer or an experienced radio/TV technician for help.