



ESP32-SL specification

Version V1.0

Copyright ©2020

Disclaimer and copyright notice

The information in this article, including the URL for reference, is subject to change without notice.

The document is provided "as is" without any guarantee responsibility, including any guarantee of marketability, suitability for a specific purpose or non-infringement, and any guarantee mentioned elsewhere in any proposal, specification or sample. This document assumes no responsibility, including any liability for infringement of any patent rights arising from the use of the information in this document. This document does not grant any license to use intellectual property rights, whether express or implied, by estoppel or other means. The test data obtained in this article are all obtained by Enxin Lab's laboratory tests, and the actual results may be slightly different.

The Wi-Fi Alliance member logo is owned by the Wi-Fi Alliance.

All trademark names, trademarks and registered trademarks mentioned in this article are the property of their respective owners and are hereby declared.

The final interpretation right belongs to Shenzhen Anxinke Technology Co., Ltd.

Attention

The contents of this manual may change due to product version upgrade or other reasons. Shenzhen Anxinke Technology Co., Ltd. reserves the right to modify the contents of this manual without any notice or prompt. This manual is only used as a guide. Shenzhen Anxinke Technology Co., Ltd. makes every effort to provide accurate information in this manual, but Shenzhen Anxinke Technology Co., Ltd. does not guarantee that the contents of the manual are completely error-free. And the suggestion does not constitute any express or implied guarantee.

CONTENT

1.PRODUCT OVERVIEW.....	V
2.ELECTRONICS PARAMETER.....	VIII
3.DIMENSION.....	X
4.PIN DEFINITION.....	XI
5.SCHEMATIC DIAGRAM.....	XIV
6.DESIGN GUIDE.....	XV
7.REFLOW SOLDERING CURVE.....	XVII
8.PACKAGING.....	XVIII
9.CONTACT US.....	XVIII

1.PRODUCT OVERVIEW

ESP32-SL is a general-purpose Wi-Fi+BT+BLE MCU module, with the industry's most competitive package size and ultra-low energy consumption technology, the size is only 18*25.5*2.8mm.

ESP32-SL can be widely used in various IoT occasions, suitable for home automation, industrial wireless control, baby monitors, wearable electronic products, wireless position sensing devices, wireless positioning system signals, and other IoT applications. It is an IoT application Ideal solution.

The core of this module is the ESP32-S0WD chip, which is scalable and adaptive. The user can cut off the power of the CPU and use the low power consumption to assist the processor to continuously monitor the status changes of peripherals or whether certain analog quantities exceed the threshold. ESP32-SL also integrates a wealth of peripherals, including capacitive touch sensors, Hall sensors, low-noise sensor amplifiers, SD card interface, Ethernet interface, high-speed SDIO/SPI, UART, I2S and I2C. The ESP32-SL module is developed by Encore Technology. The core processor ESP32 of the module has a built-in low-power Xtensa®32-bit LX6 MCU, and the main frequency supports 80 MHz and 160 MHz.

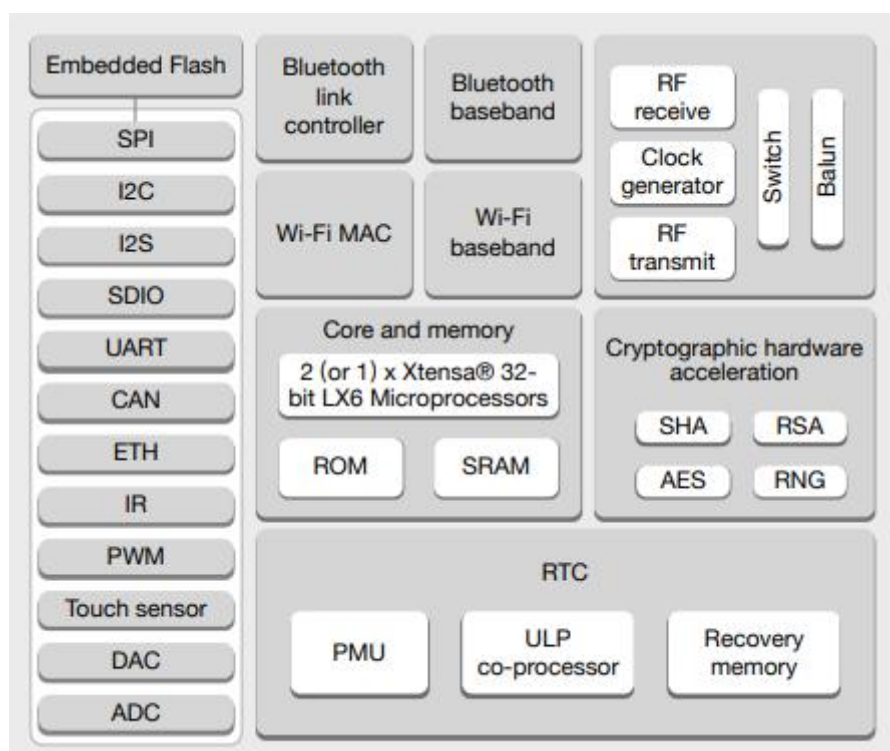

ESP32-SL adopts SMD package, which can realize the rapid production of products through standard SMT equipment, providing customers with highly reliable connection methods, especially suitable for modern production methods of automation, large-scale, and low cost, and is convenient to apply to various IoT hardware Terminal occasions.

Characteristics

- Complete 802.11b/g/n Wi-Fi+BT+BLE SOC module
- Using low-power single-core 32-bit CPU, can be used as an application processor, the main frequency is up to 160MHz, the computing power is 200 MIPS, support RTOS
- Built-in 520 KB SRAM
- Support UART/SPI/SDIO/I2C/PWM/I2S/IR/ADC/DAC
- SMD-38 packaging
- Support OpenOCD debug interface
- Support multiple sleep modes, the minimum sleep current is less than 5uA
- Embedded Lwip protocol stack and FreeRTOS
- Support STA/AP/STA+AP work mode
- Smart Config (APP)/AirKiss (WeChat) one-click distribution network supporting Android and IOS
- Support serial local upgrade and remote firmware upgrade (FOTA)
- General AT command can be used quickly
- Support secondary development, integrated Windows, Linux development environment

Major parameter

List 1 description of major parameter

Model	ESP32-SL
Packaging	SMD-38
Size	18*25.5*2.8(±0.2)MM
Antenna	PCB antenna/external IPEX
Spectrum range	2400 ~ 2483.5MHz
Work frequency	-40 °C ~ 85 °C
Store environment	-40 °C ~ 125 °C , < 90%RH
Power supply	Voltage 3.0V ~ 3.6V, current >500mA
Power consumption	Wi-Fi TX(13dBm~21dBm):160~260mA
	BT TX:120mA
	Wi-Fi RX:80~90mA
	BT RX:80~90mA
	Modem-sleep:5~10mA
	Light-sleep:0.8mA
	Deep-sleep:20μA
Hibernation:2.5μA	
Interface supported	UART/SPI/SDIO/I2C/PWM/I2S/IR/ADC/DAC
IO port quantity	22
Serial rate	Support 300 ~ 4608000 bps , default 115200 bps
Bluetooth	Bluetooth BR/EDR and BLE 4.2 standard
Safety	WPA/WPA2/WPA2-Enterprise/WPS
SPI Flash	Default 32Mbit, maximum support128Mbit

2.ELECTRONICS PARAMETER

Electronic characteristics

Parameter	Condition	Min	Typical	Max	Unit	
Voltage	VDD	3.0	3.3	3.6	V	
I/O	V_{IL}/V_{IH}	-	-0.3/0.75VIO	-	0.25VIO/3.6	V
	V_{OL}/V_{OH}	-	N/0.8VIO	-	0.1VIO/N	V
	I_{MAX}	-	-	-	12	mA

Wi-Fi RF Performance

Description	Typical	Unit
Work frequency	2400 - 2483.5	MHz
Output power		
In 11n mode, PA output power is	13±2	dBm
In 11g mode, PA output power is	14±2	dBm
In 11b mode, PA output power is	17±2	dBm
Receiving sensitivity		
CCK, 1 Mbps	≤ -98	dBm
CCK, 11 Mbps	≤ -89	dBm
6 Mbps (1/2 BPSK)	≤ -93	dBm
54 Mbps (3/4 64-QAM)	≤ -75	dBm
HT20 (MCS7)	≤ -73	dBm

BLE RF Performance

Description	Min	Typical	Max	Unit
Sending characteristics				
Sending sensitivity	-	+7.5	+10	dBm
Receiving characteristics				
Receiving sensitivity	-	-98	-	dBm

4.PIN DEFINITION

The ESP32-SL module has a total of 38 interfaces, as shown in the figure below. The following table shows the interface definitions.

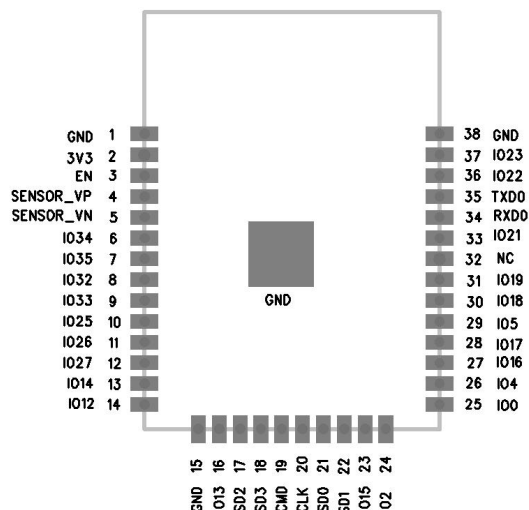

ESP32-SL PIN definition diagram

List PIN function description

No.	Name	Function description
1	GND	Ground
2	3V3	Power supply
3	EN	Enable chip, high level is effective.
4	SENSOR_VP	GPI36/ SENSOR_VP/ ADC_H/ADC1_CH0/RTC_GPIO0
5	SENSOR_VN	GPI39/SENSOR_VN/ADC1_CH3/ADC_H/ RTC_GPIO3
6	IO34	GPI34/ADC1_CH6/ RTC_GPIO4
7	IO35	GPI35/ADC1_CH7/RTC_GPIO5
8	IO32	GPIO32/XTAL_32K_P (32.768 kHz crystal oscillator input)/ ADC1_CH4/ TOUCH9/ RTC_GPIO9
9	IO33	GPIO33/XTAL_32K_N (32.768 kHz crystal oscillator output)/ADC1_CH5/TOUCH8/ RTC_GPIO8
10	IO25	GPIO25/DAC_1/ ADC2_CH8/ RTC_GPIO6/ EMAC_RXD0

11	IO26	GPIO26/ DAC_2/ADC2_CH9/RTC_GPIO7/EMAC_RXD1
12	IO27	GPIO27/ADC2_CH7/TOUCH7/RTC_GPIO17/ EMAC_RX_DV
13	IO14	GPIO14/ ADC2_CH6/ TOUCH6/ RTC_GPIO16/MTMS/HSPICLK /HS2_CLK/SD_CLK/EMAC_TXD2
14	IO12	GPIO12/ ADC2_CH5/TOUCH5/ RTC_GPIO15/ MTDI/ HSPIQ/ HS2_DATA2/SD_DATA2/EMAC_TXD3
15	GND	Ground
16	IO13	GPIO13/ ADC2_CH4/ TOUCH4/ RTC_GPIO14/ MTCK/ HSPID/ HS2_DATA3/ SD_DATA3/ EMAC_RX_ER
17	SHD/SD2	GPIO9/SD_DATA2/ SPIHD/ HS1_DATA2/ U1RXD
18	SWP/SD3	GPIO10/ SD_DATA3/ SPIWP/ HS1_DATA3/U1TXD
19	SCS/CMD	GPIO11/SD_CMD/ SPICS0/HS1_CMD/U1RTS
20	SCK/CLK	GPIO6/SD_CLK/SPICLK/HS1_CLK/U1CTS
21	SDO/SD0	GPIO7/ SD_DATA0/ SPIQ/ HS1_DATA0/ U2RTS
22	SDI/SD1	GPIO8/ SD_DATA1/ SPID/ HS1_DATA1/ U2CTS
23	IO15	GPIO15/ADC2_CH3/ TOUCH3/ MTDO/ HSPICS0/ RTC_GPIO13/ HS2_CMD/SD_CMD/EMAC_RXD3
24	IO2	GPIO2/ ADC2_CH2/ TOUCH2/ RTC_GPIO12/ HSPIWP/ HS2_DATA0/ SD_DATA0
25	IO0	GPIO0/ ADC2_CH1/ TOUCH1/ RTC_GPIO11/ CLK_OUT1/ EMAC_TX_CLK
26	IO4	GPIO4/ ADC2_CH0/ TOUCH0/ RTC_GPIO10/ HSPICLK/ HS2_DATA1/SD_DATA1/ EMAC_TX_ER
27	IO16	GPIO16/ HS1_DATA4/ U2RXD/ EMAC_CLK_OUT
28	IO17	GPIO17/ HS1_DATA5/U2TXD/EMAC_CLK_OUT_180
29	IO5	GPIO5/ VSPICS0/ HS1_DATA6/ EMAC_RX_CLK
30	IO18	GPIO18/ VSPICLK/ HS1_DATA7
31	IO19	GPIO19/VSPIQ/U0CTS/ EMAC_TXD0
32	NC	-
33	IO21	GPIO21/VSPIHD/ EMAC_TX_EN

34	RXD0	GPIO3/U0RXD/ CLK_OUT2
35	TXD0	GPIO1/ U0TXD/ CLK_OUT3/ EMAC_RXD2
36	IO22	GPIO22/ VSPIWP/ U0RTS/ EMAC_TXD1
37	IO23	GPIO23/ VSPID/ HS1_STROBE
38	GND	Ground

Strapping PIN

Built-in LDO (VDD_SDIO) Voltage					
PIN	Default	3.3V	1.8V		
MTDI/GPIO12	Pull down	0	1		
System startup mode					
PIN	Default	SPI Flash startup mode	Download startup mode		
GPIO0	Pull up	1	0		
GPIO2	Pull down	Non-sense	0		
During system startup, U0TXD outputs log print information					
PIN	Default	U0TXD Flip	U0TXD still		
MTDO/GPIO15	Pull up	1	0		
SDIO slave signal input and output timing					
PIN	Default	Falling edge output	Falling edge input	Rising edge input	Rising edge input
		Falling edge input	Rising edge output	Falling edge output	Rising edge output
MTDO/GPIO15	Pull up	0	0	1	1
GPIO5	Pull up	0	1	0	1

Note: ESP32 has 6 strapping pins in total, and the software can read the value of these 6 bits in the register "GPIO_STRAPPING". During the chip power-on reset process, the strapping pins are sampled and stored in the latches. The latches are "0" or "1" and remain until the chip is powered off or turned off. Each strapping pin is connected to internal pull-up/pull-down. If a strapping pin is not connected or the connected external line is in a high impedance state, the internal weak pull-up/pull-down will determine the default value of the strapping pin input level. To change the value of the strapping bits, the user can apply external pull-down/pull-up resistors, or apply the GPIO of the host MCU to control the level of the strapping pins at power-on reset of ESP32. After reset, the strapping pin has the same function as the normal pin.

5.SCHEMATIC DIAGRAM

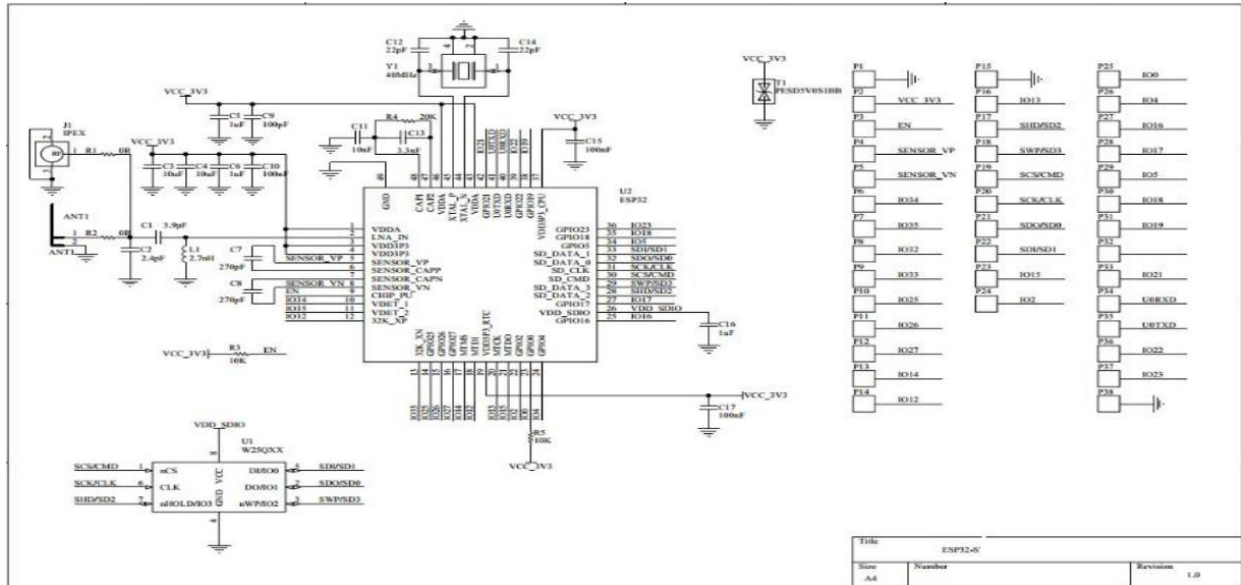

6. DESIGN GUIDE

1. Application circuit

2. Antenna layout requirements

(1) The following two methods are recommended for the installation location on the motherboard:

Option 1: Place the module on the edge of the main board, and the antenna area protrudes from the edge of the main board.

Option 2: Place the module on the edge of the motherboard, and the edge of the motherboard digs out an area at the position of the antenna.

(2) In order to meet the performance of the onboard antenna, it is forbidden to place metal parts around the antenna.

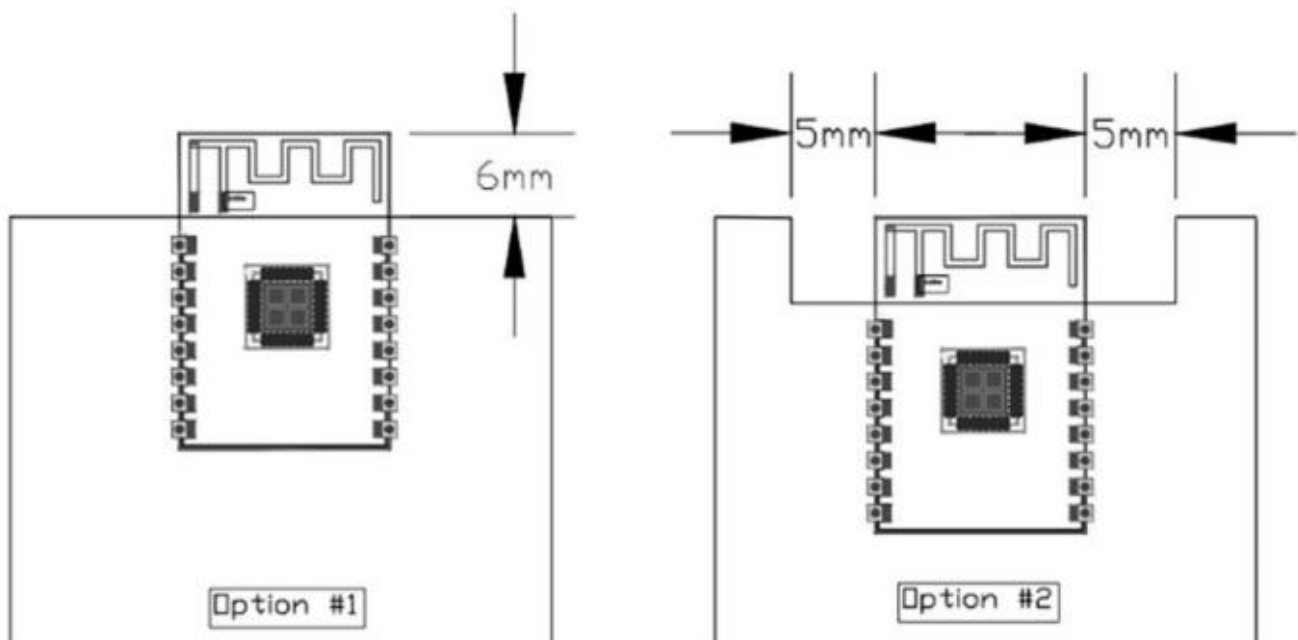

3. Power supply

(1) 3.3V voltage is recommended, the peak current is more than 500mA

(2) It is recommended to use LDO for power supply; if using DC-DC, it is recommended to control the ripple within 30mV.

(3) It is recommended to reserve the position of the dynamic response capacitor in the DC-DC power supply circuit, which can optimize the output ripple when the load changes greatly.

(4), 3.3V power interface is recommended to add ESD devices.

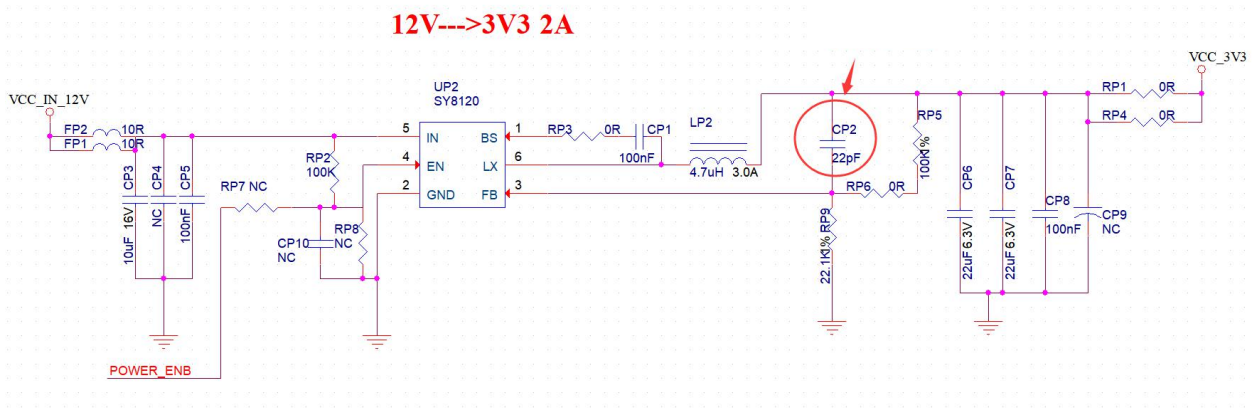

4. Use of GPIO port

- (1) Some GPIO ports are led out of the peripheral of the module. If you need to use a 10-100 ohm resistor in series with the IO port is recommended. This can suppress overshoot, and the level on both sides is more stable. Help both EMI and ESD.
- (2) For the up and down of the special IO port, please refer to the instruction manual of the specification, which will affect the startup configuration of the module.
- (3) The IO port of the module is 3.3V. If the IO level of the main control and the module does not match, a level conversion circuit needs to be added.
- (4) If the IO port is directly connected to the peripheral interface, or the pin header and other terminals, it is recommended to reserve ESD devices near the terminal of the IO trace.

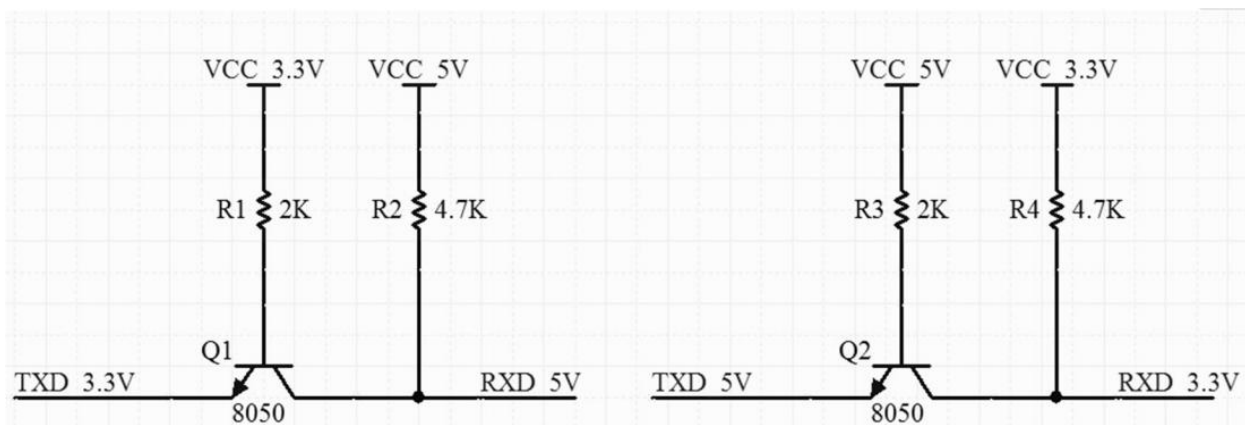
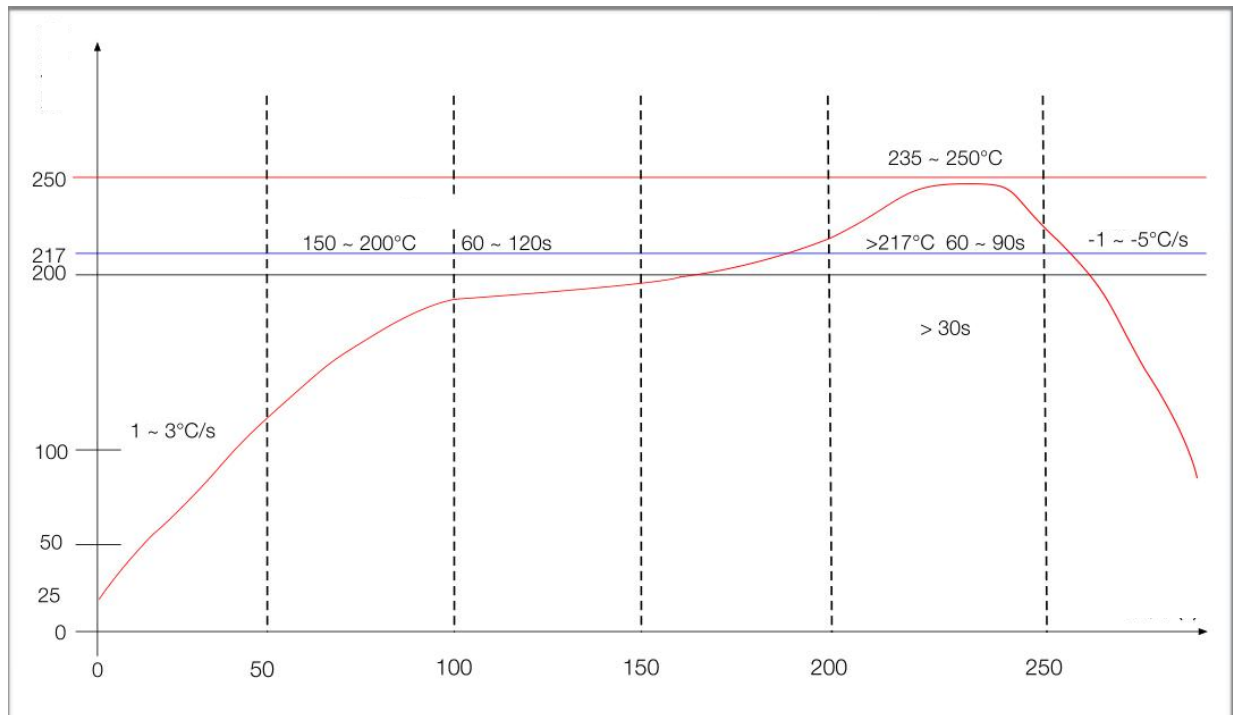

Image Level shift circuit

7. REFLOW SOLDERING CURVE



警告语以及 FCC ID 号

8.PACKAGING

As shown below, the packaging of ESP32-SL is taping.



9.CONTACT US

Web: <https://www.ai-thinker.com>

Development DOCS: <https://docs.ai-thinker.com>

Official forum: <http://bbs.ai-thinker.com>

Sample purchase: <http://ai-thinker.en.alibaba.com>

Business: sales@aithinker.com

Support: support@aithinker.com

Add: 408-410, Block C, Huafeng Smart Innovation Port, Gushu 2nd Road, Xixiang, Baoan District, Shenzhen

Tel: 0755-29162996



OEM/Integrators Installation Manual

Important Notice to OEM integrators

INTEGRATION INSTRUCTIONS

FCC rules

The ESP32-SL is an WIFI+BT Module Module with frequency hopping using an ASK modulation. It operates on the 2400 ~2500 MHz band and, therefore, is within U.S. FCC part 15.247 standard.

Modular installation instruction

- 1,ESP32-SL Integrates high-speed GPIO and peripheral interface. Please pay attention to the installation direction (pin direction).
- 2,Antenna could not be in no-load state when module is working. During debugging, it is suggested to add 50 ohms load to the antenna port to avoid damage or performance degradation of the module under long-time no-load condition.
- 3,When the module needs to output 31dBm or more power, it needs a voltage supply of 5.0V or more to achieve the expected output power.
- 4,When working at full load, it is recommended that the entire bottom surface of the module be attached to the housing or heat dissipation plate, and it is not recommended to conduct heat dissipation through air or screw column heat conduction.
- 5,UART1 and UART2 are serial ports with the same priority. The port which receives commands returns information.

Trace antenna designs

Not Applicable

RF exposure considerations

To maintain compliance with FCC's RF Exposure guidelines, This equipment should be installed and operated with minimum distance between 20cm the radiator your body: Use only the supplied antenna.

Antennas

The ESP32-SL is an UHF RFID Module beams signals and communicates with its antenna, which is Panel Antenna.

LABEL OF THE END PRODUCT

The final end product must be labeled in a visible area with the following :

Host must Contains FCC ID: 2ATPO-ESP32-SL. If the size of the end product is larger than 8x10cm, then the following FCC part 15.19 statement has to also be available on the label: This device complies with Part 15 of FCC rules. Operation is subject to the following two conditions:

- (1) this device may not cause harmful interference and
- (2) this device must accept any interference received, including interference that may cause undesired operation.

Information on test modes and additional testing requirements5

Data transfer module demo board can control the EUT work in RF test mode at specified test

channel.

Additional testing, Part 15 Subpart B disclaimer

The module without unintentional-radiator digital circuit, so the module does not required an evaluation by FCC Part 15 Subpart B. The host should be evaluated by the FCC Subpart B.

ATTENTION

This device is intended only for OEM integrators under the following conditions: 1) The antenna must be installed such that 20 cm is maintained between the antenna and users, and

2) This device and its antenna(s) must not be co - located with any other transmitters except in accordance with FCC multi - transmitter product procedures. Referring to the multi - transmitter policy, multiple transmitter(s) and module(s) can be operated simultaneously without C2P.

3) For all products market in US, OEM has to limit the Operating Frequency: 2400 ~2500MHz by supplied firmware programming tool. OEM shall not supply any tool or info to the end - user regarding to Regulatory Domain change.

USERS MANUAL OF THE END PRODUCT:

In the user manual of the end product, the end user has to be informed to keep at least 20cm separation with the antenna while this end product is installed and operated. The end user has to be informed that the FCC radio - frequency exposure guidelines for an uncontrolled environment can be satisfied. The end user has to also be informed that any changes or modifications not expressly approved by the manufacturer could void the user's authority to operate this equipment.

If the size of the end product is smaller than 8x10cm, then additional FCC part 15.19 statement is required to be available in the users manual: This device complies with Part 15 of FCC rules.

Operation is subject to the following two conditions:

- (1) this device may not cause harmful interference and
- (2) this device must accept any interference received, including interference that may cause undesired operation.

FCC WARNING

This device complies with part 15 of the FCC Rules. Operation is subject to the following two conditions:

Any changes or modifications not expressly approved by the party responsible for compliance could void the user's authority to operate the equipment.

NOTE: This equipment has been tested and found to comply with the limits for a Class B digital device, pursuant to Part 15 of the FCC Rules. These limits are designed to provide reasonable protection against harmful interference in a residential installation. This equipment generate, uses and can radiate radio frequency energy and, if not installed and used in accordance with the instructions, may cause harmful interference to radio communications. However, there is no guarantee that interference will not occur in a particular installation.

If this equipment does cause harmful interference to radio or television reception, which can be determined by turning the equipment off and on, the user is encouraged to try to correct the interference by one or more of the following measures:

- Reorient or relocate the receiving antenna.
- Increase the separation between the equipment and receiver.
- Connect the equipment into an outlet on a circuit different from that to which the receiver is connected.
- Consult the dealer or an experienced radio/TV technician for help.