



ESP-S3-32S Specification

Version V1.0.0

Copyright ©2022

Document Resume

Version	Date	Develop/revise content	Edition	Approve
V1.0.0	2022.01.15	First Edition	ChaoMeiDeng	NingGuan

Content

1. Product Overview.....	4
1.1. Characteristic.....	6
2. Module configuration specification.....	7
3. Main parameters.....	8
3.1. Static electricity requirements.....	8
3.2. Electrical Characteristics.....	9
3.3. Wi-Fi RF performance.....	9
3.4. BLE RF performance.....	10
3.5. Power consumption.....	11
4. Appearance dimensions.....	12
5. Pin definition.....	13
6. Schematic.....	16
7. Antenna parameters.....	17
7.1. Antenna test diagram.....	17
7.2. Antenna S parameters.....	18
7.3. Antenna Gain and Efficiency.....	18
7.4. Antenna pattern.....	19
8. Design Guidance.....	20
8.1. Module application circuit guidance.....	20
8.2. Antenna layout requirements.....	21
8.3. Power supply.....	22
8.4. Use of GPIO port.....	23
9. Reflow soldering curve.....	24
10. Product related models.....	25
11. Product packaging information.....	26
12. Contact us.....	26
Disclaimer and copyright notice.....	27
Notice.....	27

1. Product Overview

ESP-S3-32S is a Wi-Fi+BLE module developed by Shenzhen Ai-Thinker Technology Co., LTD. The core processor chip ESP32-S3 is a highly integrated, low-power Wi-Fi and Bluetooth system-on-chip (SoC), designed for Internet of Things (IoT), mobile devices, wearable electronics, smart home and other applications

ESP-S3-32S module has industry-leading low-power performance and RF performance, and supports Wi-Fi IEEE802.11b/g/n protocol and Bluetooth 5.0. The module is equipped with an Xtensa-R 32-bit LX7 dual-core processor with a working frequency of up to 240 MHz. Support secondary development without using other microcontrollers or processors. The module has built-in 512 KB SRAM, 384 KB ROM, 16KB RTC SRAM. The module supports a variety of low-power working states, which can meet the power consumption requirements of various application scenarios. The unique features of the chip, such as fine clock gating function, dynamic voltage clock frequency adjustment function, and RF output power adjustment function, can achieve the best balance between communication distance, communication rate and power consumption.

ESP-S3-32S module provides rich peripheral interfaces, including UART, PWM, SPI, I2S, I2C, ADC, LCD, DVP, RMT(TX/RX), pulse counter, USB OTG, USB Serial/JTAG, SDIO, DMA controller, TWAI controller, temperature sensor, capacitive sensor and up to 36 IO ports.

ESP-S3-32S module has a variety of unique hardware security mechanisms. The module hardware cryptographic accelerator supports AES, SHA and RSA algorithms. Among them, RNG, HMAC and digital signature (Digital Signature) provide more security mechanisms for the module. Other security features include Flash encryption and secure boot signature verification. The perfect security mechanism enables the module to be perfectly applied to various encryption products.

ESP-S3-32S module supports Bluetooth Low Energy: Bluetooth5.0, Bluetooth mesh. Bluetooth rate support: 125Kbps, 500Kbps, 1Mbps, 2Mbps. Support broadcast extension, multi-broadcast, channel selection.

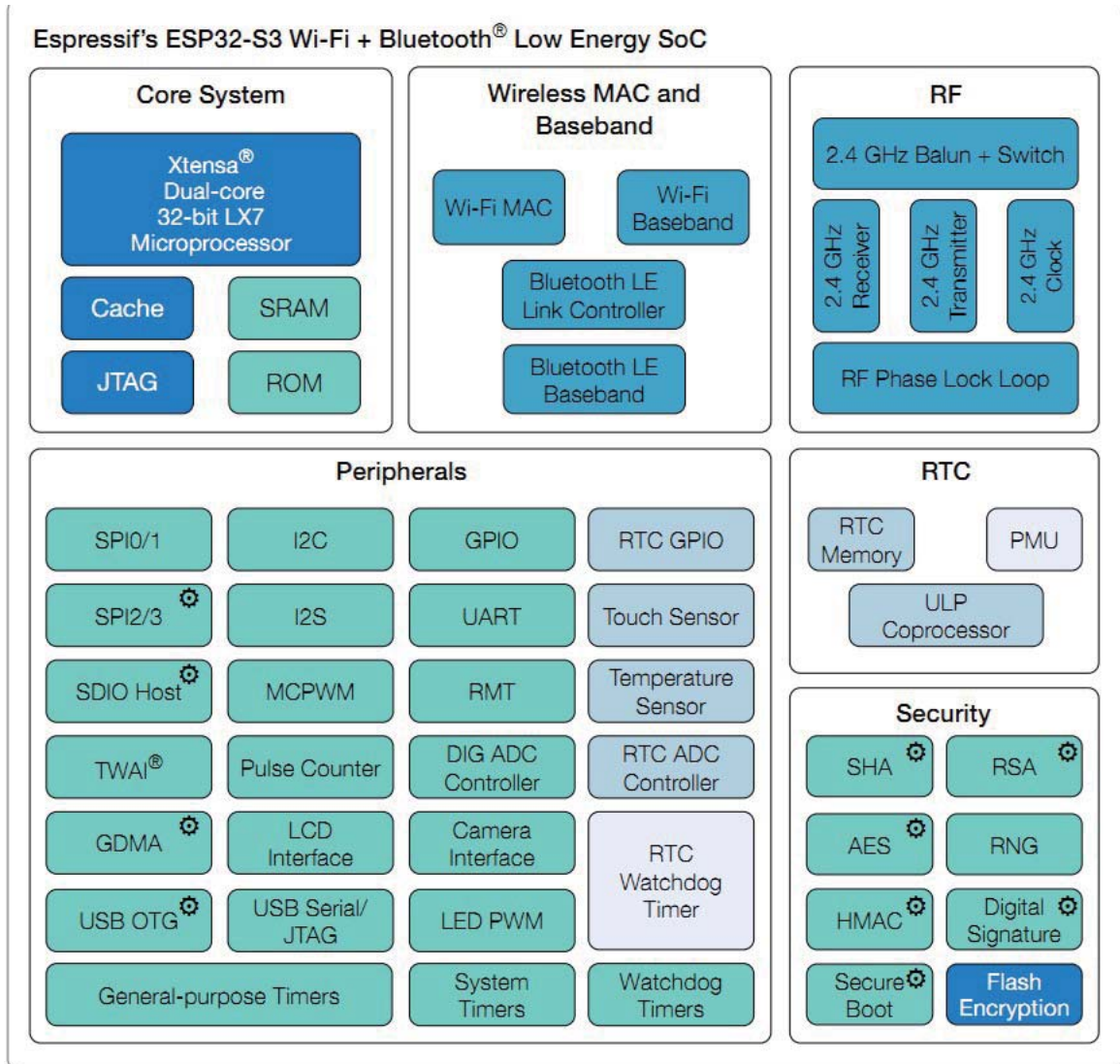

Figure 1 Main chip architecture diagram

1.1. Characteristic

- Support Wi-Fi 802.11b/g/n, 1T1R mode data rate up to 150Mbps
- Support Bluetooth5.0, Bluetooth mesh, rate support: 125Kbps, 500Kbps, 1Mbps, 2Mbps
- Xtensa-R 32-bit LX7 dual-core processor, supports up to 240 MHz clock frequency, has 512KB SRAM, 384KB ROM, 16KB RTC SRAM
- Support UART/GPIO/ADC/PWM/I2C/I2S/SPI/LCD/DVP/RMT/SDIOMCPWM/DMA controller/TWAI /USB OTG/USB Serial/controller interface, temperature sensor, pulse counter, capacitive sensor GPIO
- Using SMD-40 package
- Integrated Wi-Fi MAC/BB/RF/PA/LNA/Bluetooth
- Support multiple sleep modes, deep sleep current is less than 8uA
- Serial port rate up to 5Mbps
- Support STA/AP/STA+AP mode and promiscuous mode
- Support Smart Config (APP)/AirKiss (WeChat) for Android and IOS with one-click network configuration
- Support serial port local upgrade and remote firmware upgrade (FOTA)
- General AT commands can be used quickly
- Support secondary development, integrated Windows and Linux development environment

2. Module configuration specification

ESP-S3-32S module has a variety of configurations to choose from, which can be distinguished according to the laser engraving silk screen on the shield, refer to Table 1 for details.

- Regarding the flash capacity and working temperature of the module, if you have special requirements, you can contact Ai-Thinker for customization.

Table 1 Module configuration description

Silk Screen Printing of shield	Chip	Flash(MB)	PSRAM(MB)	Operating temperature
S3OFN8	ESP32-S3	8	/	-40~85°C
S3IFN8	ESP32-S3FN8	8	/	-40~85°C

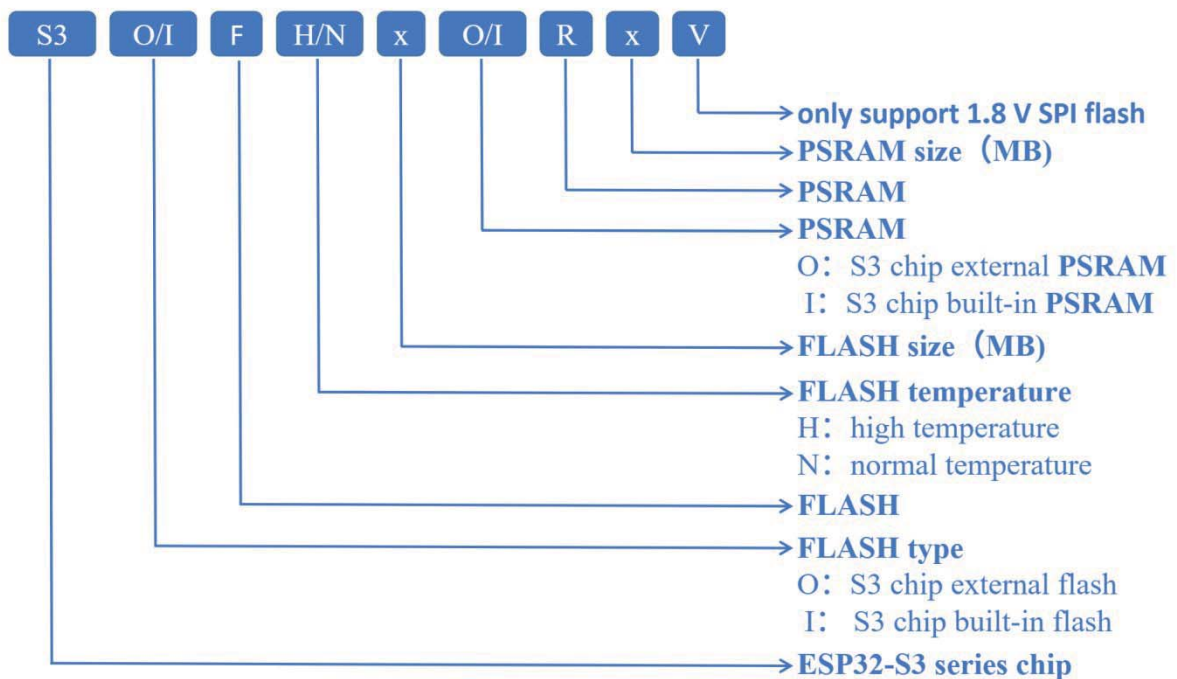

Figure 2 Module Silk Screen Printing of shield naming convention

3. Main parameters

Table 2 Description of the main parameters

Model	ESP-S3-32S
Package	SMD-40
Size	25.5*18.0*3.2(±0.2)mm
Antenna	On-board antenna or IPEX external antenna
Frequency	2400 ~ 2483.5MHz
Operating temperature	-40 °C ~ 85 °C
Storage temperature	-40 °C ~ 125 °C 箐 < 90%RH
Power supply	Support voltage: 3.0V ~ 3.6V 箐 supply current >500mA
Interface	UART/GPIO/ADC/PWM/I2C/I2S/SPI/LCD/DVP/RMT/SDIO/USB OTG/MCPWM/DMA/TWAI
IO	36
UART rate	Support 110 ~ 4608000 bps 箐 default 115200 bps
Bluetooth	Bluetooth 5.0 箐 Bluetooth mesh
Security	WEP/WPA-PSK/WPA2-PSK
SPI Flash	8MByte 箐 default 箐 Optional 4/16MByte

3.1. Static electricity requirements

The ESP-S3-32S module is a static-sensitive device and requires special precautions when handling it.



Figure 3 ESD anti-static diagram

3.2. Electrical Characteristics

Table 3 Electrical Characteristics Table

Parameters		Conditio	Min.	Typical	Max.	Unit
Support voltageae		VDD	3.0	3.3	3.6	V
I/O	V_{IL}/V_{IH}	-	-0.3/0.75VDD	-	0.25VDD/VDD+0.3	V
	V_{OL}/V_{OH}	-	N/0.8VIO	-	0.1VIO/N	V
	I_{MAX}	-	-	-	40	mA

3.3. Wi-Fi RF performance

Table 4 Wi-Fi RF performance table

Description	Typical value			Unit
Working Central Frequency	2412 - 2484			MHz
Output Power				
Rate model	Min.	Typical value	Max.	Unit
11n model HT40 ㄑPA output power	13	15	17	dBm
11n model HT20 ㄑPA output power	13	15	17	dBm
11g model ㄑPA output power	14	16	18	dBm
11bmodel ㄑPA output power	16	18	20	dBm
Receive Sensitivity				
Rate model	Min.	Typical value	Max.	Unit
11b ㄑ1 Mbps	-	-97	-	dBm
11b ㄑ11 Mbps	-	-88	-	dBm
11g, 6 Mbps	-	-92	-	dBm
11g ㄑ54 Mbps	-	-75	-	dBm
11n ㄑHT20 (MCS7)	-	-73	-	dBm
11n ㄑHT40 (MCS7)	-	-70	-	dBm

3.4. BLE RF performance

Table 5 BLE RF performance table

Description	Typical value			Unit
Working Central Frequency	2402 - 2480			MHz
Output Power				
Rate model	Min.	Typical	Max.	Unit
1Mbps	-25	0	19	dBm
2Mbps	-25	0	19	dBm
Receive Sensitivity				
Rate model	Min.	Typical	Max.	Unit
1Mbps sensitivity@30.8%PER	-	-96	-	dBm
2Mbps sensitivity@30.8%PER	-	-92	-	dBm

3.5. Power consumption

The following power consumption figures are based on a 3.3V supply, 25°C ambient temperature, and are measured using the internal voltage regulator.

- All measurements are made at the antenna interface with filters.
- All transmit data is based on 100% duty cycle, measured in continuous transmit mode.

Table 6 Power consumption table

Model	Min.	AVG	Max.	Unit
Tx 802.11b 管 DSSS 1Mbps 管 POUT=+20dBm	-	350	-	mA
Tx 802.11g 管 OFDM 54Mbps 管 POUT =+18dBm	-	290	-	mA
Tx 802.11n 管 MCS7 管 POUT =+17dBm	-	280	-	mA
Rx 802.11b 管 1024 bit	-	97	-	mA
Rx 802.11g 管 1024 bit	-	97	-	mA
Rx 802.11n 管 1024 bit	-	100	-	mA
Modem-Sleep ^①	-	20	-	mA
Light-Sleep ^②	-	240	-	μA
Deep-Sleep ^③	-	8	-	μA
Power Off	-	1	-	μA

4. Appearance dimensions

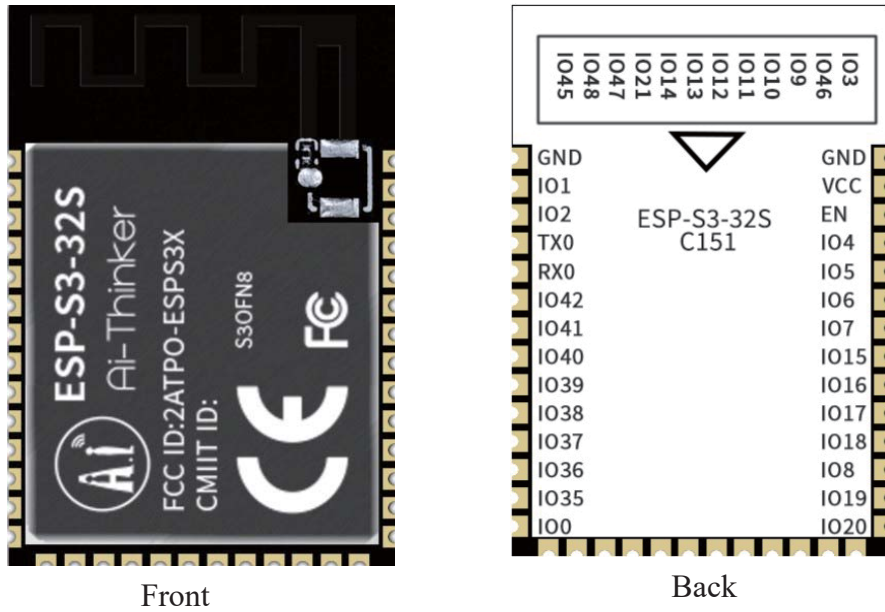

Figure 4 Appearance of the module (the rendering is for reference only, the actual product shall prevail)

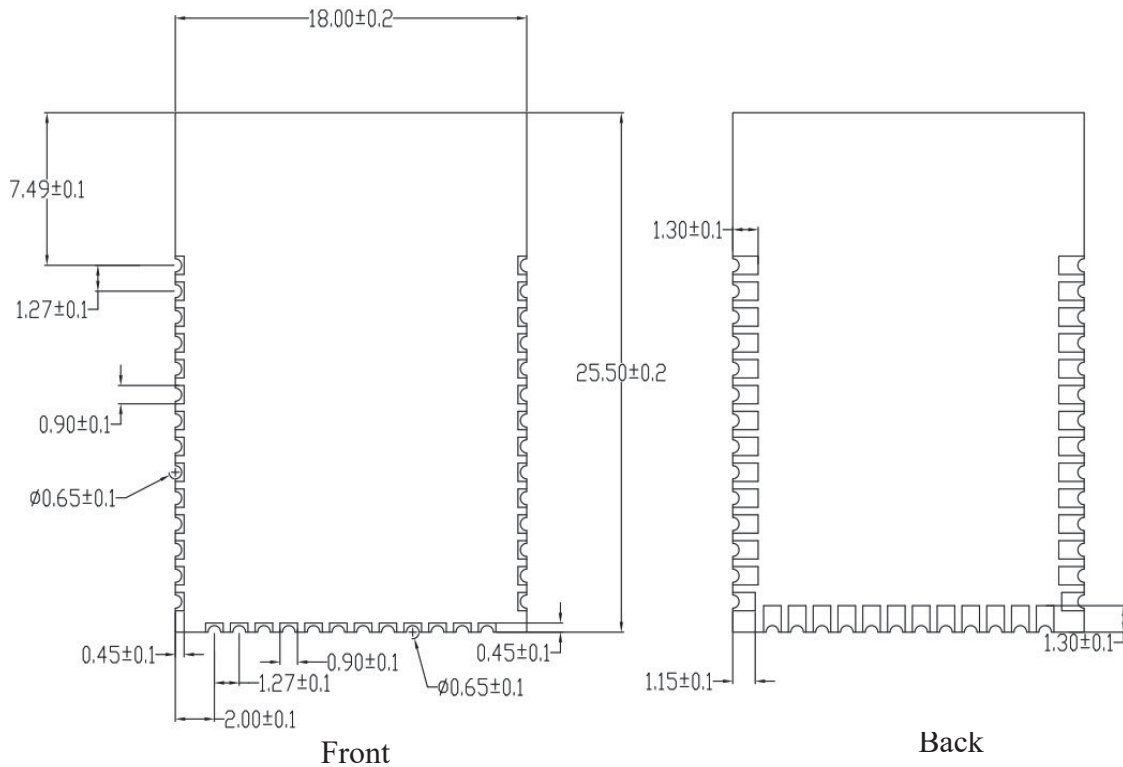

Figure 5 Module Dimensions

5. Pin definition

ESP-S3-32S module has a total of 40 pins, as shown in the pin diagram, the pin function definition table is the interface definition.

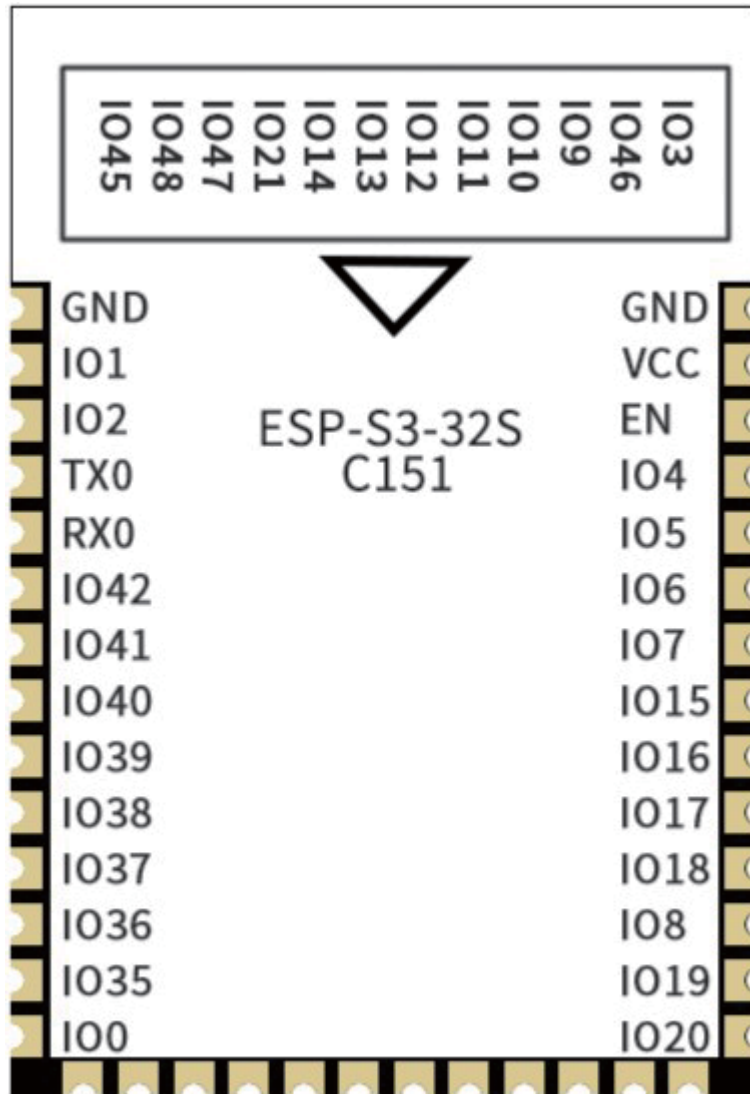

Figure 6 Schematic diagram of module pins (bottom view)

Table 7 Pin function definition table

No.	Name	Function
1管40	GND	GND , Power negative electrode
2	VCC	Power supply, positive electrode
3	EN	High level: module on Low level: module off Be careful not to leave the EN pin floating
4	IO4	RTC_GPIO4,GPIO4,TOUCH4,ADC_CH3
5	IO5	RTC_GPIO5,GPIO5,TOUCH5,ADC1_CH4
6	IO6	RTC_GPIO6,GPIO6,TOUCH6,ADC1_CH5
7	IO7	RTC_GPIO7,GPIO7,TOUCH7,ADC1_CH6
8	IO15	RTC_GPIO15,GPIO15,U0RTS,ADC2_CH4, XTAL_32K_P
9	IO16	RTC_GPIO16,GPIO16,U0CTS,ADC2_CH5, XTAL_32K_N
10	IO17	RTC_GPIO17,GPIO17,U1TXD,ADC2_CH6
11	IO18	RTC_GPIO18,GPIO18,U1RXD,ADC2_CH7, CLK_OUT3
12	IO8	RTC_GPIO8,GPIO8,TOUCH8,ADC1_CH7, SUBSPICS1
13	IO19	RTC_GPIO19,GPIO19,U1RTS,ADC2_CH8, CLK_OUT2,USB_D-
14	IO20	RTC_GPIO20,GPIO20,U1CTS,ADC2_CH9, CLK_OUT1,USB D+
15	IO3	GPIO3,RTC_GPIO3,TOUCH3,ADC1_CH2
16	NC	Default NC, BOM can be specified as GPIO46
17	IO9	GPIO9,RTC_GPIO9,TOUCH9,ADC1_CH8, SUBSPIHD,FSPiHD
18	IO10	RTC_GPIO10,GPIO10,TOUCH10,ADC1_CH9, FSPIIO4,SUBSPICS0,FSPICS0
19	IO11	RTC_GPIO11,GPIO11,TOUCH11,ADC2_CH0, FSPIIO5,SUBSPID,FSPID
20	IO12	RTC_GPIO12,GPIO12,TOUCH12,ADC2_CH1, FSPIIO6,SUBSPICLK,FSPICLK
21	IO13	RTC_GPIO13,GPIO13,TOUCH13,ADC2_CH2, FSPIIO7,SUBSPIQ,FSPiQ

22	IO14	RTC_GPIO14,GPIO14,TOUCH14,ADC2_CH3, FSPIDQS,SUBSPIWP,FSPIWP
23	IO21	RTC_GPIO21,GPIO21
24	IO47	SPICLK_P_DIFF,GPIO47,SUBSPICLK_P_DIFF
25	IO48	SPICLK_N_DIFF,GPIO48,SUBSPICLK_N_DIFF
26	IO45	GPIO45
27	IO0	GPIO0,RTC_GPIO0
28	IO35	GPIO35,FSPID,SUBSPID,SPIIO6
29	IO36	GPIO36,FSPICLK,SUBSPICLK,SPIIO7
30	IO37	GPIO37,FSPIQ,SUBSPIQ,SPIDQS
31	IO38	GPIO38,FSPIWP,SUBSPIWP
32	IO39	MTCK,GPIO39,CLK_OUT3,SUBSPICS1
33	IO40	MTDO,GPIO40,CLK_OUT2
34	IO41	MTD1,GPIO41,CLK_OUT1
35	IO42	MTMS,GPIO42,
36	U0RX	U0RXD,GPIO44,CLK_OUT2
37	U0TX	U0TXD,GPIO43,CLK_OUT1
38	IO2	RTC_GPIO2,GPIO2,TOUCH2,ADC1_CH1
40	IO1	GPIO1,RTC_GPIO1,TOUCH1,ADC1_CH0

Table 8 Module startup mode description

System boot mode			
Pin	Default	SPI start-up model	Reboot download-Mode
IO0	Pull-Up	1	0
IO46	pull-down	/	0

Note: Some pins have been pulled up internally, please refer to the schematic diagram.

6. Schematic

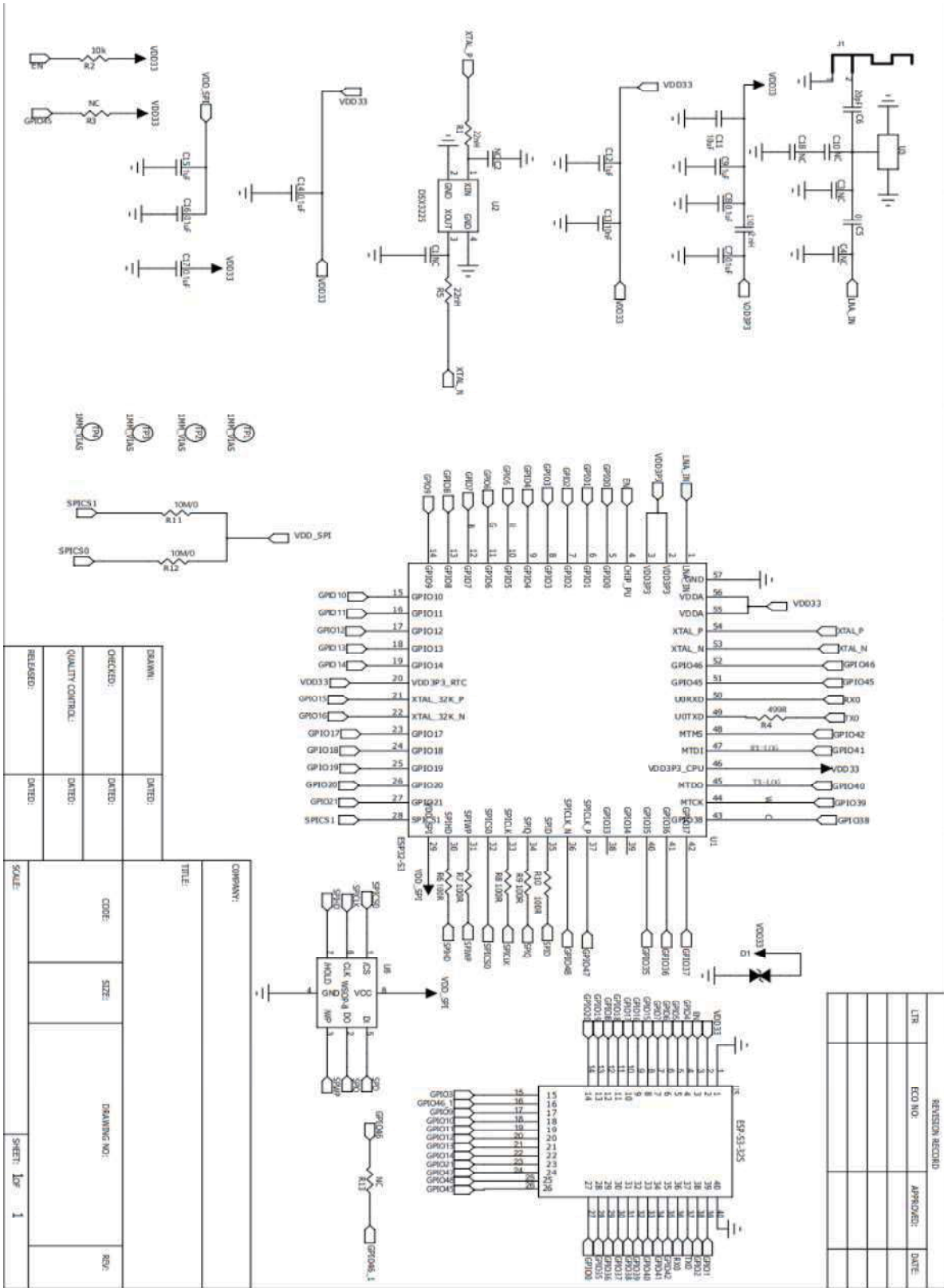

Figure7 Schematic diagram of the module

7. Antenna parameters

7.1. Antenna test diagram



Figure 8 illustrates the use of the user welding the module to the motherboard

7.2. Antenna S parameters

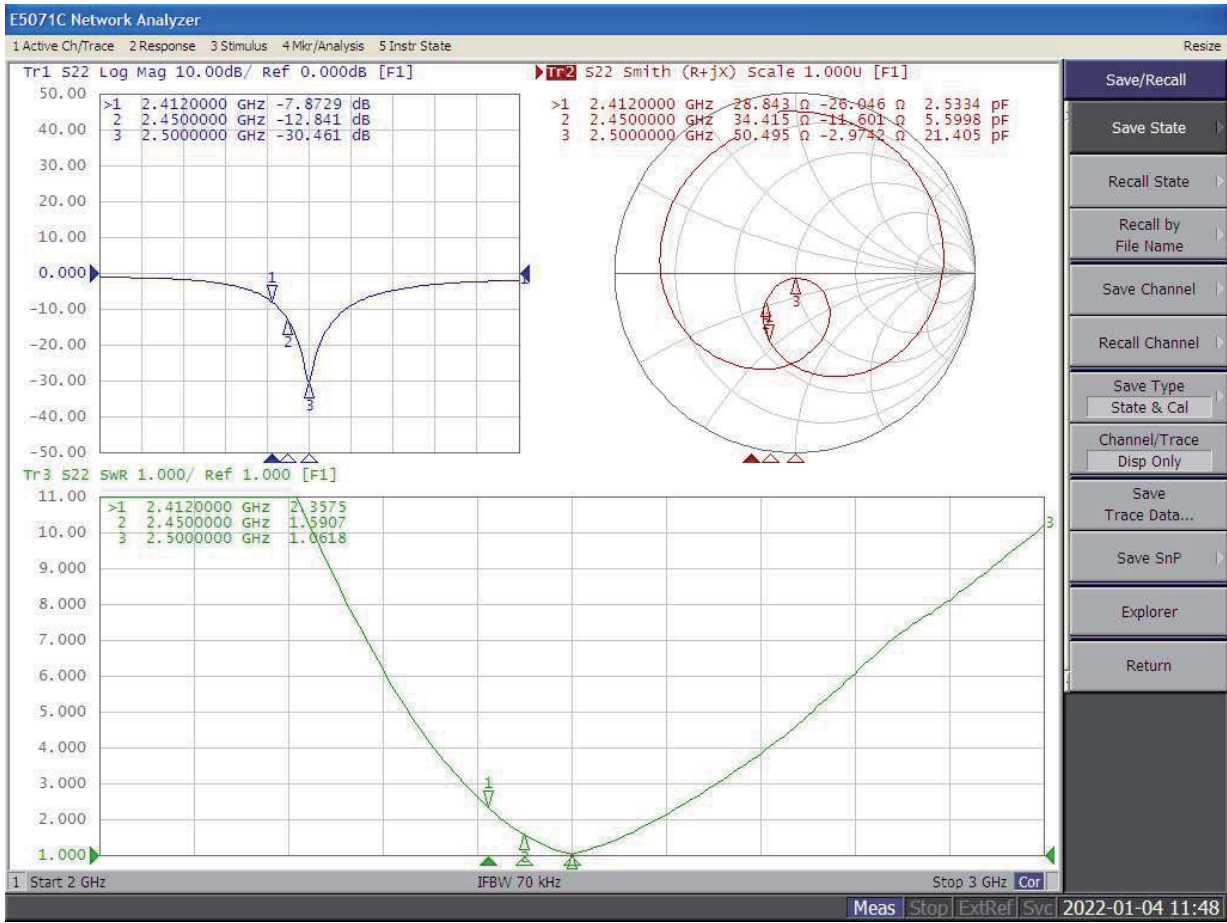

Figure 9 Antenna S parameters

7.3. Antenna Gain and Efficiency

Table 9 Antenna gain and efficiency

Frequency ID	1	2	3	4	5	6	7	8	9	10	11
Frequency (MHz)	2400.0	2410.0	2420.0	2430.0	2440.0	2450.0	2460.0	2470.0	2480.0	2490.0	2500.0
Gain (dBi)	2.27	2.44	2.63	2.79	2.89	3.13	3.22	3.26	3.17	3.22	3.04
Efficiency (%)	54.2	55.7	57.1	58.7	60.3	64.6	67.2	68.9	67.5	67.9	63.9

7.4. Antenna pattern

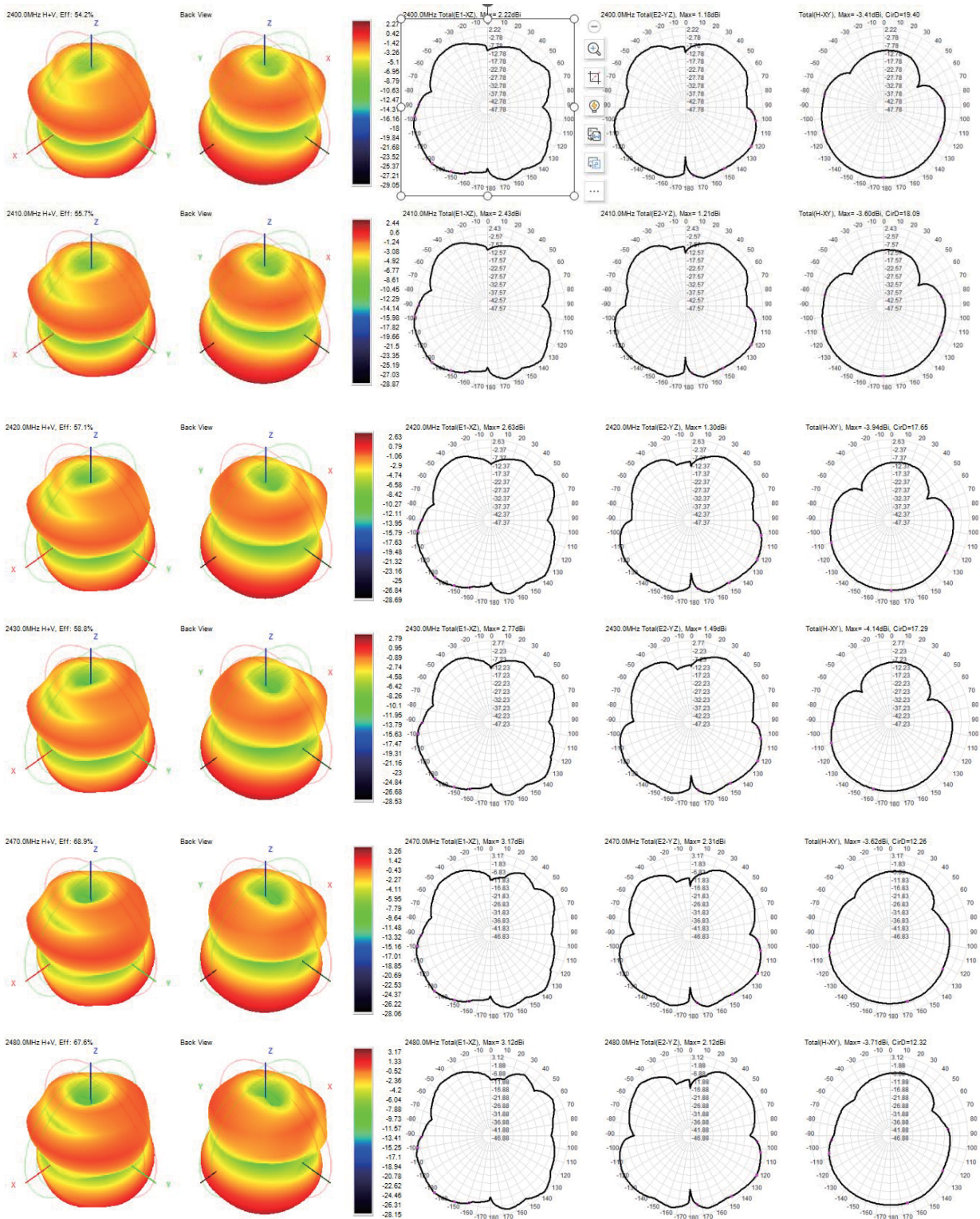

Figure 10 Antenna field pattern

8. Design Guidance

8.1. Module application circuit guidance

(>= 500mA, it is recommended to use DC-DC or LDO for independent power supply)

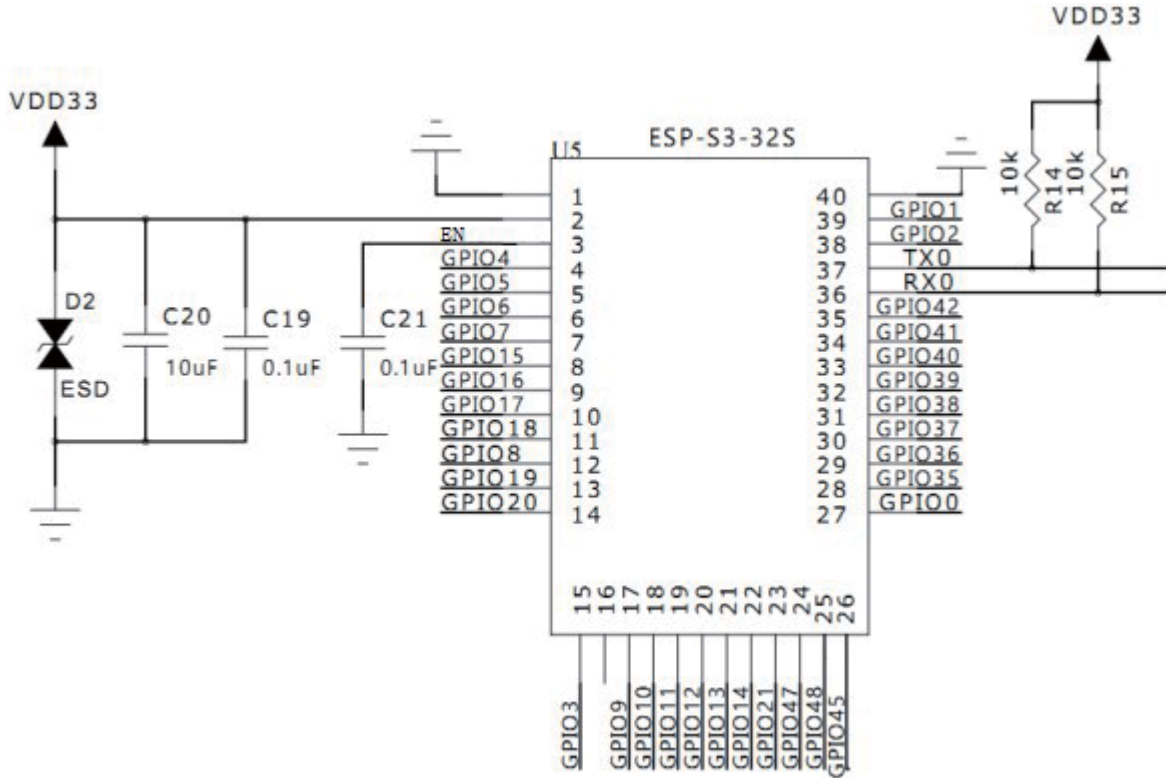

Figure 11 Application circuit diagram

Notice:

- U0RX0 and U0TX0 need to add a pull-up resistor externally, while U0RX0 is connected to the TX of another machine, and U0TX0 is connected to the RX of another machine.

8.2. Antenna layout requirements

- The following two methods are recommended for the installation position on the motherboard:

Solution 1: Put the module on the edge of the motherboard, and the antenna area extends out of the edge of the motherboard.

Option 2: Put the module on the edge of the motherboard, and hollow out an area on the edge of the motherboard at the antenna position.

- In order to meet the performance of the on-board antenna, it is forbidden to place metal parts around the antenna and keep away from high-frequency devices.

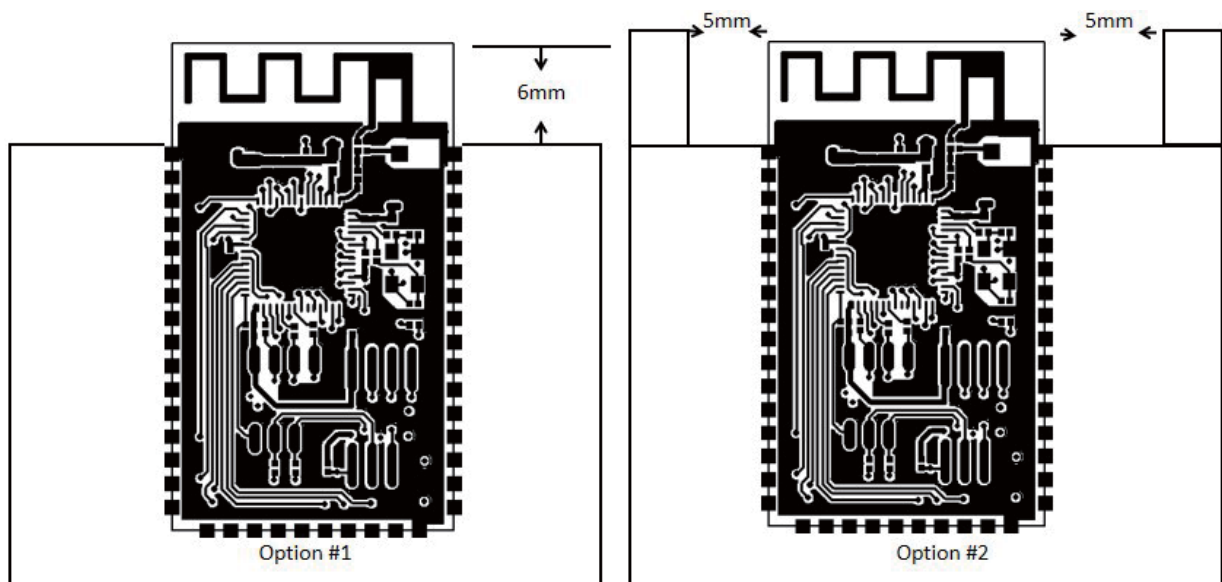

Figure 12 Schematic diagram of antenna layout

8.3. Power supply

- Recommended 3.3V voltage, peak current above 500mA.
- It is recommended to use LDO for power supply; if DC-DC is used, it is recommended that the ripple be controlled within 30mV.
- It is recommended to reserve the position of the dynamic response capacitor for the DC-DC power supply circuit, which can optimize the output ripple when the load changes greatly.
- It is recommended to add ESD devices to the 3.3V power interface.

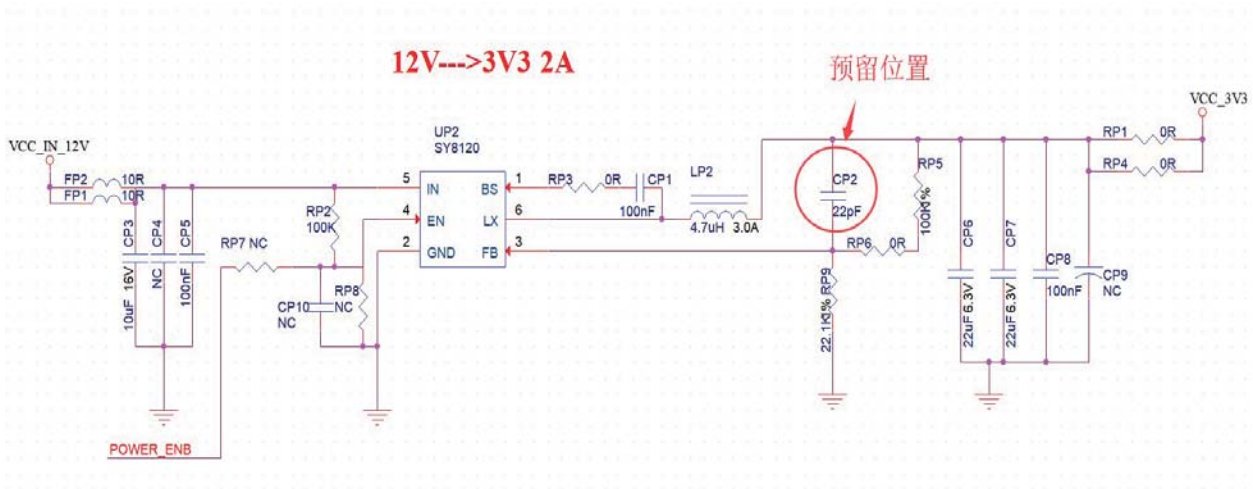

Figure 13 DC-DC step-down circuit diagram

8.4. GPIO

- There are some IO ports on the periphery of the module. If you need to use it, it is recommended to connect a 10-100 ohm resistor in series with the IO port. This suppresses overshoot and makes the level on both sides smoother. Helps with both EMI and ESD.
- For the pull-up and pull-down of the special IO port, please refer to the instruction manual of the specification, which will affect the startup configuration of the module.
- The IO port of the module is 3.3V. If the level of the main control and the IO port of the module does not match, a level conversion circuit needs to be added.
- If the IO port is directly connected to a peripheral interface, or a terminal such as a pin header, it is recommended to reserve an ESD device near the terminal of the IO port trace.

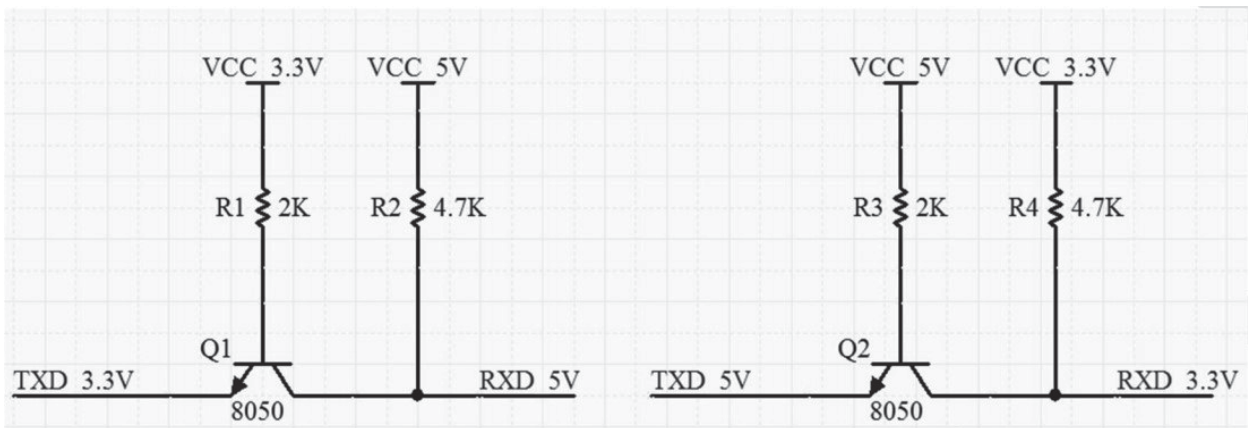

Figure 14 Level conversion circuit

9. Reflow soldering curve

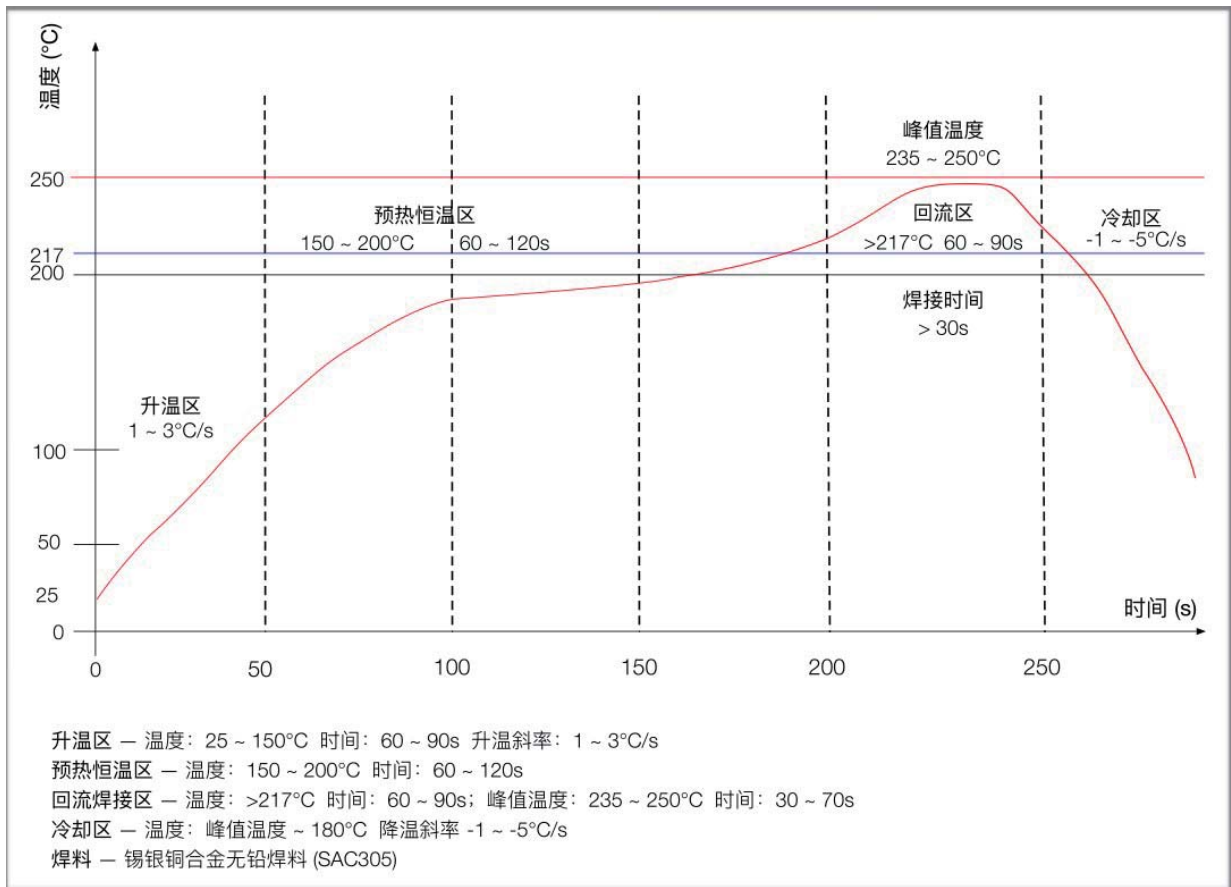

Figure 15 Reflow Soldering Curve

10. Product related models

Table 10 Product related model list

Model	Power Supply	Package	Size	Antenna
ESP-S3-12K	3.0V ~ 3.6V I>500mA	SMD-42	31.0*18.0*3.2(±0.2)mm	The on-board PCB antenna or external antenna connector is compatible
ESP-S3-32S	3.0V ~ 3.6V I>500mA	SMD-40	25.5*18.0*3.2(±0.2)mm	The on-board PCB antenna or external antenna connector is compatible
NodeMCU-ESP-S3-32S	5V, I>500mA	DIP42	61.0*25.5*12.9 (±0.2)mm	The on-board PCB antenna
NodeMCU-ESP-S3-12K	5V, I>500mA	DIP42	58.5*25.5*12.9 (±0.2)mm	The on-board PCB antenna
Product related information https://docs.ai-thinker.com				

11. Product packaging information

The ESP-S3-32S module is packaged with tape, 800pcs/reel. As shown below:



Figure 16 Packaging Taping Diagram

12. Contact us

[Ai-Thinker official website](#)

[Office forum](#)

[Develop DOCS](#)

[LinkedIn](#)

[Tmall shop](#)

[Taobao shop](#)

[Alibaba shop](#)

Technic support email support@aithinker.com

Domestic business cooperation sales@aithinker.com

Overseas business cooperation overseas@aithinker.com

Company Address [Room 403,408-410, Block C, Huafeng Smart Innovation Port, Gushu 2nd Road, Xixiang, Baoan District, Shenzhen.](#)

Tel [+86-0755-29162996](tel:+86-0755-29162996)



Wechat mini program

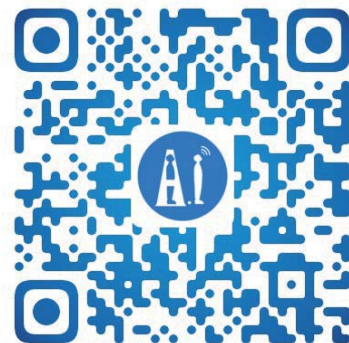

Wechat official account

Disclaimer and copyright notice

The information in this article,including the URL address for reference,is subject to change without notice.

The document is provided"as is"without any guarantee responsibility,including any guarantee for merchantability,suitability for a specific purpose,or non-infringement,and any guarantee mentioned elsewhere in any proposal,specification or sample.This document does not bear any responsibility,including the responsibility for infringement of any patent rights arising from the use of the information in this document.This document does not grant any license for the use of intellectual property rights in estoppel or other ways,whether express or implied.

The test data obtained in the article are all obtained from Ai-Thinker's laboratory tests,and the actual results may vary slightly.

All brand names,trademarks and registered trademarks mentioned in this article are the property of their respective owners,and it is hereby declared.

The final interpretation right belongs to Shenzhen Ai-Thinker Technology Co.,Ltd.

Notice

Due to product version upgrades or other reasons,the contents of this manual may be changed.

Shenzhen Ai-Thinker Technology Co.,Ltd reserves the right to modify the contents of this manual without any notice or prompt.

This manual is only used as a guide.Shenzhen Ai-Thinker Technology Co.,Ltd. makes every effort to provide accurate information in this manual.However, Shenzhen Ai-Thinker Technology Co.,Ltd. does not guarantee that the contents of the manual are completely free of errors.All statements and information in this manual And the suggestion does not constitute any express or implied guarantee.

FCC WARNING

FCC Caution: Any changes or modifications not expressly approved by the party responsible for compliance could void the user's authority to operate this equipment.

This device complies with Part 15 of the FCC Rules.

Operation is subject to the following two conditions: (1) This device may not cause harmful interference, and (2) this device must accept any interference received, including interference that may cause undesired operation.

This device and its antenna(s) must not be co-located or operating in conjunction with any other antenna or transmitter.

15.105 Information to the user.

(b) For a Class B digital device or peripheral, the instructions furnished the user shall include the following or similar statement, placed in a prominent location in the text of the manual:

Note: This equipment has been tested and found to comply with the limits for a Class B digital device, pursuant to part 15 of the FCC Rules.

These limits are designed to provide reasonable protection against harmful interference in a residential installation. This equipment generates, uses and can radiate radio frequency energy and, if not installed and used in accordance with the instructions, may cause harmful interference to radio communications. However, there is no guarantee that interference will not occur in a particular installation. If this equipment does cause harmful interference to radio or television reception, which can be determined by turning the equipment off and on, the user is encouraged to try to correct the interference by one or more of the following measures:

- Reorient or relocate the receiving antenna.
- Increase the separation between the equipment and receiver.
- Connect the equipment into an outlet on a circuit different from that to which the receiver is connected.
- Consult the dealer or an experienced radio/TV technician for help.

This equipment complies with FCC radiation exposure limits set forth for an uncontrolled environment. This equipment should be installed and operated with minimum distance 20

cm between the radiator and your body.

Radiation Exposure Statement:

This equipment complies with FCC radiation exposure limits set forth for an uncontrolled environment.

This transmitter must not be co-located or operating in conjunction with any other

antenna or transmitter.

The availability of some specific channels and/or operational frequency bands are country dependent and are firmware programmed at the factory to match the intended destination.

The firmware setting is not accessible by the end user.

The final end product must be labelled in a visible area with the following:

“Contains Transmitter Module FCC ID“2ATPO-ESP-S3-32S”

Requirement per KDB996369 D03

2.2 List of applicable FCC rules

List the FCC rules that are applicable to the modular transmitter. These are the rules that specifically establish the bands of operation, the power, spurious emissions, and operating fundamental frequencies. DO NOT list compliance to unintentional-radiator rules (Part 15 Subpart B) since that is not a condition of a module grant that is extended to a host manufacturer. See also Section 2.10 below concerning the need to notify host manufacturers that further testing is required.³

Explanation: This module meets the requirements of FCC part 15C (15.247). It specifically identified AC Power Line Conducted Emission, Radiated Spurious emissions, Band edge and RF Conducted Spurious Emissions, Conducted Peak Output Power, Bandwidth, Power Spectral Density, Antenna Requirement.

Summarize the specific operational use conditions

Describe use conditions that are applicable to the modular transmitter, including for example any limits on antennas, etc. For example, if point-to-point antennas are used that require reduction in power or compensation for cable loss, then this information must be in the instructions. If the use condition limitations extend to professional users, then instructions must state that this information also extends to the host manufacturer's instruction manual. In addition, certain information may also be needed, such as peak gain per frequency band and minimum gain, specifically for master devices in 5 GHz DFS bands.

Explanation: The product antenna uses an irreplaceable antenna with a gain of 1.5dBi
Limited module procedures

If a modular transmitter is approved as a "limited module," then the module manufacturer is responsible for approving the host environment that the limited module is used with. The manufacturer of a limited module must describe, both in the filing and in the installation instructions, the alternative means that the limited module manufacturer uses to verify that the host meets the necessary requirements to satisfy the module limiting conditions.

A limited module manufacturer has the flexibility to define its alternative method to address the conditions that limit the initial approval, such as: shielding, minimum signaling amplitude, buffered modulation/data inputs, or power supply regulation. The alternative method could include that the limited

module manufacturer reviews detailed test data or host designs prior to giving the host manufacturer approval.

This limited module procedure is also applicable for RF exposure evaluation when it is necessary to demonstrate compliance in a specific host. The module manufacturer must state how control of the product into which the modular transmitter will be installed will be maintained such that full compliance of the product is always ensured. For additional hosts other than the specific host originally granted with a limited module, a Class II permissive change is required on the module grant to register the additional host as a specific host also approved with the module.

Explanation: The module is a single module.

2.6 RF exposure considerations

It is essential for module grantees to clearly and explicitly state the RF exposure conditions that permit a host product manufacturer to use the module. Two types of instructions are required for RF exposure information: (1) to the host product manufacturer, to define the application conditions (mobile, portable – xx cm from a person's body); and (2) additional text needed for the host product manufacturer to provide to end users in their end-product manuals. If RF exposure statements and use conditions are not provided, then the host product manufacturer is required to take responsibility of the module through a change in FCC ID (new application).

Explanation: The module complies with FCC radiofrequency radiation exposure limits for uncontrolled environments. The device is installed and operated with a distance of more than 20 cm between the radiator and your body." This module follows FCC statement design, FCC ID :2ATPO-ESP-S3-32S

Antennas

A list of antennas included in the application for certification must be provided in the instructions. For modular transmitters approved as limited modules, all applicable professional installer instructions must be included as part of the information to the host product manufacturer. The antenna list shall also identify the antenna types (monopole, PIFA, dipole, etc. (note that for example an "omni-directional antenna" is not considered to be a specific "antenna type")).

For situations where the host product manufacturer is responsible for an external connector, for example with an RF pin and antenna trace design, the integration instructions shall inform the installer that unique antenna connector must be used on the Part 15 authorized transmitters used in the host product.

The module manufacturers shall provide a list of acceptable unique connectors.

Explanation: The product antenna uses an irreplaceable antenna with a gain of 1.5dBi

2.7 Label and compliance information

Grantees are responsible for the continued compliance of their modules to the FCC rules. This

includes advising host product manufacturers that they need to provide a physical or e-label stating "Contains FCC ID" with their finished product. See Guidelines for Labeling and User Information for RF Devices – KDB Publication 784748.

Explanation: The host system using this module, should have label in a visible area indicated the following texts: "Contains FCC ID: 2ATPO-ESP-S3-32S."

2.8 Information on test modes and additional testing requirements

Additional guidance for testing host products is given in KDB Publication 996369 D04 Module Integration Guide. Test modes should take into consideration different operational conditions for a stand-alone modular transmitter in a host, as well as for multiple simultaneously transmitting modules or other transmitters in a host product.

The grantee should provide information on how to configure test modes for host product evaluation for different operational conditions for a stand-alone modular transmitter in a host, versus with multiple, simultaneously transmitting modules or other transmitters in a host.

Grantees can increase the utility of their modular transmitters by providing special means, modes, or instructions that simulates or characterizes a connection by enabling a transmitter. This can greatly simplify a host manufacturer's determination that a module as installed in a host complies with FCC requirements.

Explanation: Shenzhen Ai-Thinker Technology Co., Ltd. can increase the utility of our modular transmitters by providing instructions that simulates or characterizes a connection by enabling a transmitter.

2.9 Additional testing, Part 15 Subpart B disclaimer

The grantee should include a statement that the modular transmitter is only FCC authorized for the specific rule parts (i.e., FCC transmitter rules) listed on the grant, and that the host product manufacturer is responsible for compliance to any other FCC rules that apply to the host not covered by the modular transmitter grant of certification. If the grantee markets their product

as being Part 15

Subpart B compliant (when it also contains unintentional-radiator digital circuitry), then the grantee shall provide a notice stating that the final host product still requires Part 15 Subpart B compliance testing with the modular transmitter installed.

Explanation: The module without unintentional-radiator digital circuitry, so the module does not require an evaluation by FCC Part 15 Subpart B. The host should be evaluated by the FCC Subpart B.