



YOLINK

Weatherproof Temperature & Humidity

Sensor

YS8005-UC

User Guide

Rev 1.0

Thank you for purchasing YoLink products and for entrusting us with your smart home needs! Your 100% satisfaction is our goal. If you experience any problems with setting up your new YoLink Weatherproof Temperature & Humidity Sensor, please give us a chance to assist you, before returning your purchase.

We at Customer Support are here for you. If you need any assistance installing, setting up or using a YoLink product or our app.



Find additional support and ways to reach us at:

www.yosmart.com/support-and-service

Or scan this QR code with your smartphone



Email us, 24/7 at:

service@yosmart.com



Call us, 9AM to 5PM Pacific Standard Time at:

(949) 825-5958



You may chat with us on Facebook (non-urgent matters):

www.facebook.com/YoLinkbyYoSmart

Sincerely,

Queenie, Clair, James, Eric

Customer Support Team

Contents

A. In the Box	1
B. Introduction	2
C. Set Up	4
D. Using the YoLink App	7
E. Maintenance	13
F. Specifications	17
G. Troubleshooting	19
H. Warning	20
I . Customer Service & Warranty	22

Revised: 04/08/2021

Copyright 2021. YoSmart, Inc. All rights reserved

A. In the Box

A. Weatherproof Temperature & Humidity Sensor

B. Quick Start Guide

A.



B.



B. Introduction





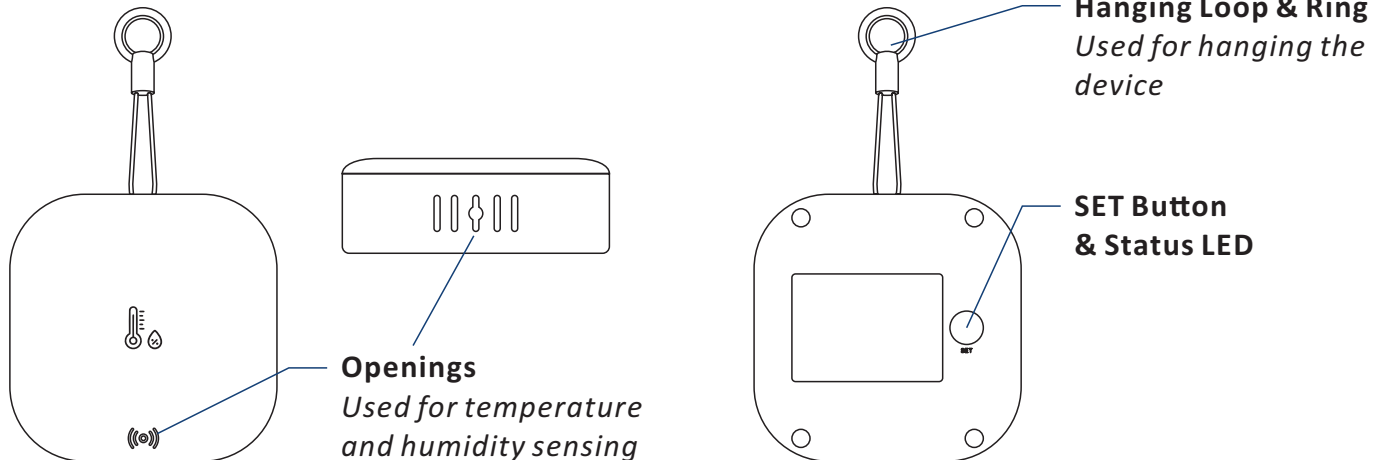

The Weatherproof Temperature & Humidity Sensor is a smart two-in-one accurate thermometer and hygrometer device. By monitoring the real-time temperature and humidity levels in your home or business, you will know at any time the exact temperature and humidity levels in the space. You can set high and low levels alerts for temperature and humidity. When an alert level is reached, the LED will blink red once, and notifications will be sent to you via the YoLink app. Available notification types are: email, and banner (“push”) notifications on your Apple or Android smartphone, each configurable in app settings.

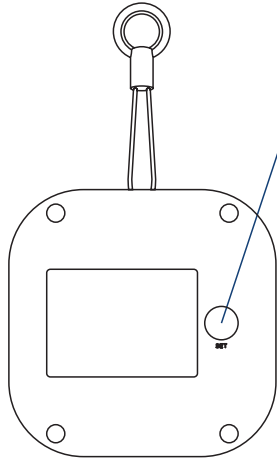
*High-volume use fees may apply (subscription service available)



The LED light indicates the current status of the Weatherproof Temperature & Humidity Sensor:



-  **Blinking Red Once, then Green Once**
Device turned on
-  **Blinking Red And Green Alternately**
Restoring to Factory Defaults
-  **Blinking Green**
Connecting to Cloud
-  **Slow Blinking Green**
Updating
-  **Blinking Red Once**
Device alerts or device is connected to the cloud and is functioning normally
-  **Fast Blinking Red Every 30 Seconds**
Batteries are low; please replace the batteries (see page 15)

C. Set Up

C-1. Set Up - First-Time YoLink Users *(Existing users proceed to C-2. Add Device, next page)*

- 1 Download the YoLink app through Apple App Store or Google Play Store (Search in the store or use the QR code on the right)



!

Apple iPhone or tablet that is iOS 9.0 or higher, or an Android phone or tablet that is Android 4.4 or higher

- 2 Log in to the YoLink app

! Create a new account if required

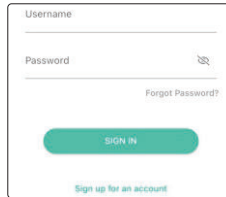

!

1. Make sure your Hub is connected to the internet (green LED indicator is blinking, blue LED indicator is always on)
2. Ethernet patch cable (included) to your network (router, switch, etc.), recommended. Otherwise connect your Hub to your home 2.4 GHz Wi-Fi network (only when necessary). Refer to the Hub set up manual for more information:



YS1603-UC
User Guide

- 3 The YoLink Hub is required to set up your Weatherproof Temperature & Humidity Sensor. Please set up your YoLink Hub first (refer to YoLink Hub manual)

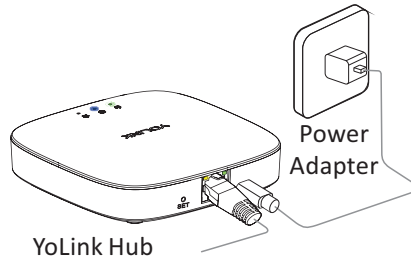

C-2. Add Device

- 1 Tap “” button, then scan QR Code on the device. Follow the steps to add the device

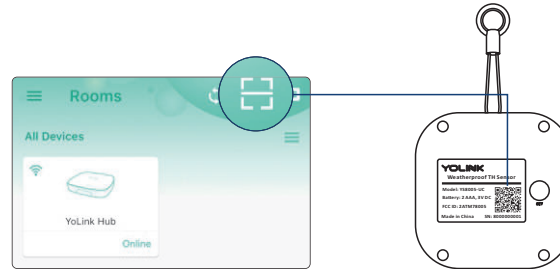

- 2 Press the SET button once to turn on the device. The Status LED will blink red once, then green several times, indicating your device has connected to the cloud and is ready to use

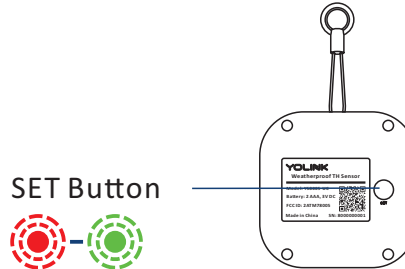

1. You will need to press the SET button once again if the device failed to connect to the cloud
2. Pressing the SET button at any other time after this initial process will result in the LED blinking red once, only. This indicates the device is connected to the cloud and is functioning normally
3. If the red LED does NOT blink as noted this may indicate a problem with the sensor. Please see the troubleshooting section and the contact section for technical support

C-3. Device Placement

- Wall-mounting: hang the sensor from the wall, on a nail or screw or other secure object, using the mounting ring
- Surface-, Shelf- or countertop-mounting: place the sensor on a stable surface so that it will not fall off or be knocked down



1. The sensor must NOT be submerged
2. For accurate readings, do not obstruct the openings on the sensor
3. Do not place the sensor on or near sources of extreme heat or cold
4. While this device is designed for outdoor use, refer to the environment operating range information on page 17. Use of this device for applications outside of the environmental operating range is likely to damage the sensor, which is NOT covered by the warranty

D. Using the YoLink App

D-1. Device Page

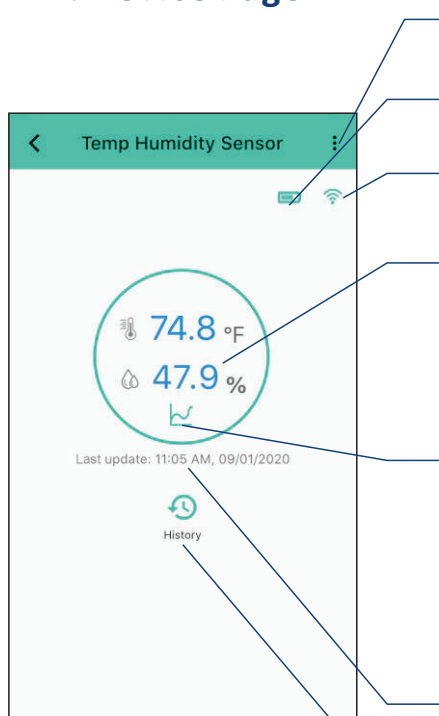

Details

- Tap to go to Details page (refer to page 9)



Battery Level

of Weatherproof Temperature & Humidity Sensor
- Shown red if battery level is low



Connection Status

of Weatherproof Temperature & Humidity Sensor and Hub



Latest Refresh Temperature Value & Humidity Value

- Blue: Normal, Red: Warning

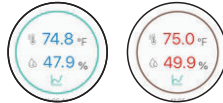

Chart for History Value

of temperature and humidity
- Hourly: last **twenty-four** hours; Daily: last **seven** days
- Download the history values of last **seven** days



Latest Refresh time

for Temperature & Humidity Value
- Sensor refresh frequency (refer to page 8)



Device Alert History

Historical log of temperature and humidity alerts, logged with date & time



Sensor Refresh Frequency

- Both temperature and humidity values refresh when one of the following conditions are met:

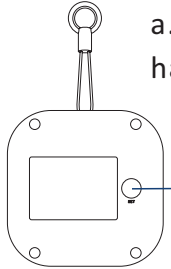

a. The SET button has been pressed

SET Button

The diagram shows a rectangular sensor device with a circular ring at the top. A small circular button on the right side is labeled 'SET Button' with a line pointing to it.



b. At least 0.9°F(0.5°C) change over a period longer than 1 minute

The icon is a thermometer with a vertical scale and a bulb at the bottom.



c. At least 3.6°F(2°C) change within 1 minute

The icon is a thermometer with a vertical scale and a bulb at the bottom.



d. At least 10% change over a period longer than 1 minute

The icon shows two water droplets of different sizes.



e. Device alert level reached or restored to normal range

The icon is a red bell with sound waves, and a black bell with a diagonal slash through it, indicating an alert.

d. Otherwise, the values will be refreshed automatically once an hour

D-2. Details Page

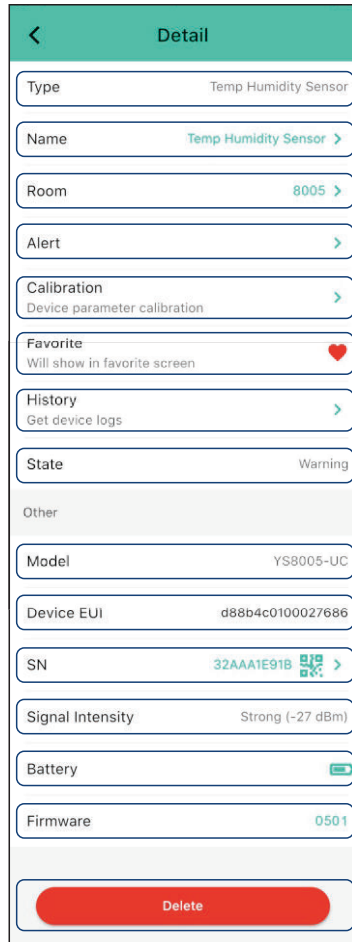

a. Device Type

b. Rename the Device

c. Choose a Room for device

d. Alert Settings

- Enable or disable alerts

a. Set alert range for temperature or humidity

b. Set re-notification interval after a temperature or humidity alert (refer to page 10)

e. A calibration Value for temperature or humidity

f. Switch Temperature Display Mode: °F / °C

g. Add/Remove from favorites

h. Historical Log of temperature and humidity alerts, logged with date & time

i. Real-time Status: Normal, Warning

j. Device Model

k. Device EUI (unique)

l. Device SN (unique)

m. Connection Status of sensor and Hub

n. Current Battery Level

- Shown red if battery level is low

o. Firmware Version

- "#### ready now" indicates a new update is available (refer to page 13)

p. Remove Device From Current Account

- Tap to delete the device from your YoLink account



After changing "Alert" and / or "Calibration" settings, press the device's SET button once, to sync the new settings to the device. Otherwise, the device will automatically update within 4 hours (maximum)

Alert Settings

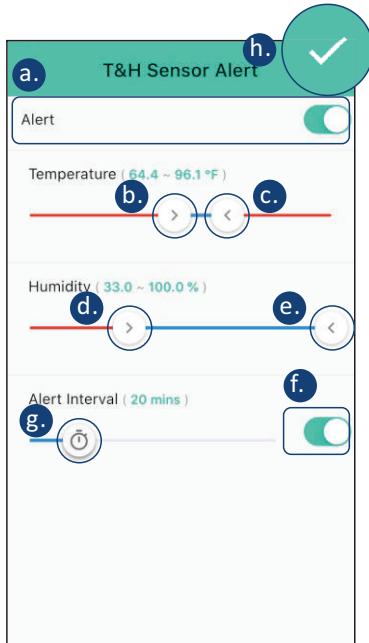

a. Enable or disable alert

- Receive notifications when the temperature value or humidity value is below the low alert value or above the high alert value set below

b. Slide to set the low temperature alert value (Default is 64°F (18°C))

c. Slide to set the High temperature alert value (Default is 95°F (35°C))

d. Slide to set the low humidity alert value (Default is 0%)

e. Slide to set the high humidity alert value (Default is 100%)

f. Enable or disable re-notification after a temperature or humidity alert

g. Set the re-notification duration between additional alerts

h. Tap to save the settings

Desired range of temperature

- Device will alert outside of this range

Desired range of humidity

- Device will alert outside of this range

Re-notification interval

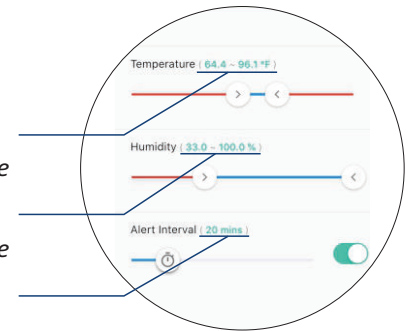

D-3. Automation

- Go to the “Smart” screen, tap “Automation”



The Weatherproof Temperature & Humidity Sensor can be set as a trigger only, with four trigger options: Low Temperature Alert; High Temperature Alert; Low Humidity Alert; High Humidity Alert

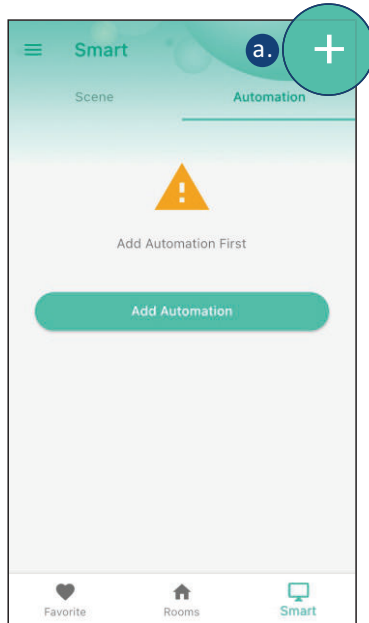

- Tap the “+” icon to add an automation

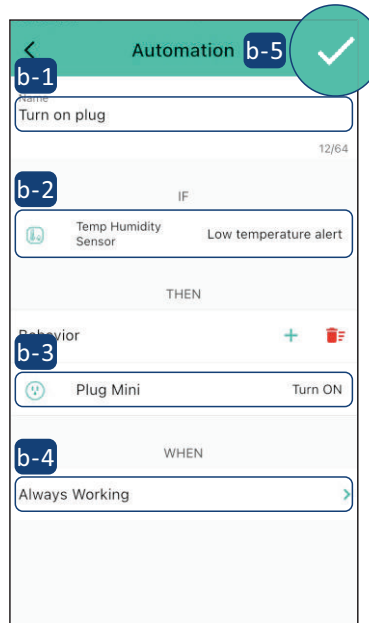

- Add an automation

b-1 Edit name

b-2 Edit trigger

b-3 Edit behavior (*You must have at least one action device, or you cannot set a behavior*)

b-4 Edit when (*Set a time range for the automation: always or during specific days or times*)

b-5 Tap to save the settings

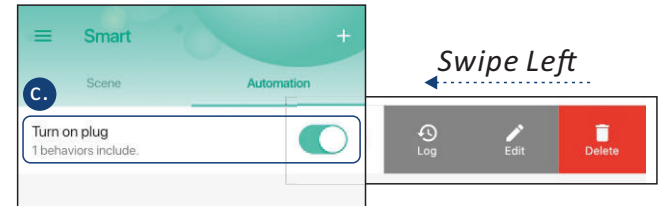

- Click to edit the automation

1. Tap “☑” button to enable or disable the automation

2. Swipe left to view the history logs and to edit or delete the automation

D-4. Voice Assistants

Connect YoLink with Alexa to monitor the status of your devices through voice commands

- Tap “☰” in the upper left corner to go to My Profile
- Go to **Settings** > **Voice Assistants** for the applicable voice assistant integration guide

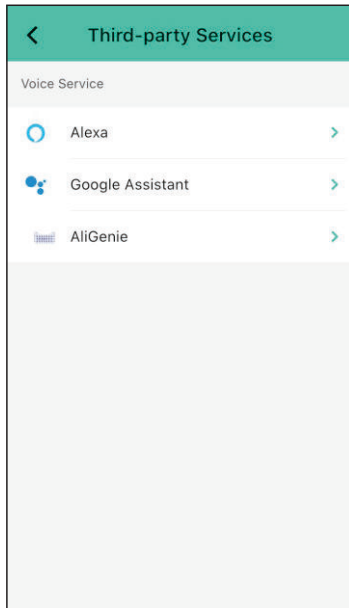

YoLink Weatherproof Temperature & Humidity Sensor is integrated with Alexa, and is also integrated with **IFTTT.com** (works as a trigger device using IFTTT)

E. Maintenance

E-1. Firmware Update

To ensure our customers have the best user experience, we highly recommend you update to the newest version firmware when an update is available

- In “Firmware”, if a new version is listed as available (#### ready now), click it to start the firmware update process
- The device's firmware will be updated automatically within 1 hours (maximum). To force an immediate update, press the SET button on the device twice to make the device enter update mode
- You may use your device during the update as it is performed in the background. The LED light will slowly blink green during the update and the process will be complete within 2 minutes after the light stops blinking

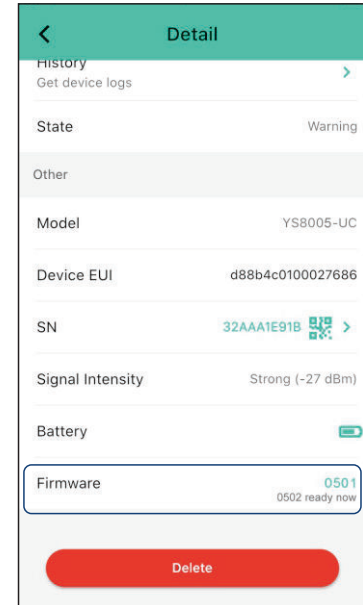

E-2. Factory Reset

Factory reset will erase all of your settings and restore it to factory defaults. After the factory reset, your device will remain in your Yolink account

- Hold the SET button for 20-25 seconds until the status light blinks red and green alternately, then, release the button (*Hold the SET button longer than 25 seconds will ABORT the factory reset operation*)
- Factory reset will be complete when the status light stops blinking

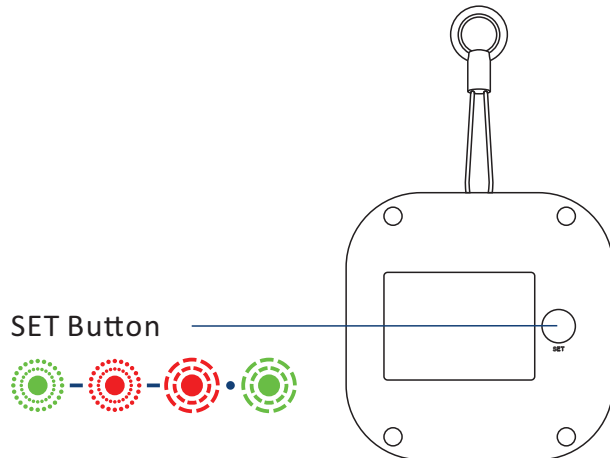

E-3. Replacing the Batteries

Tools Required:



Small Philips
Screwdriver

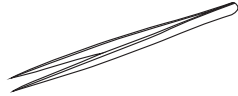

Tweezers

1. To maintain the watertight design of your Weatherproof Temperature & Humidity Sensor, use extreme care and follow the battery replacement instructions closely



2. Do not mix old and new batteries

3. Make sure that the bottom shell and sealed rubber pads are tightly secured. Otherwise, the entry of water into the sensor may cause severe damage

- 1 Use tweezers to take out the four sealed rubber pads at the base of the device

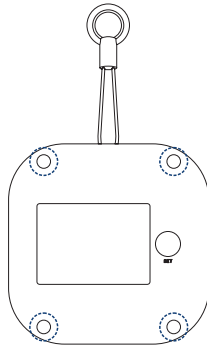

- 2 Use a screwdriver to unscrew the screws at the base of the device and remove the base

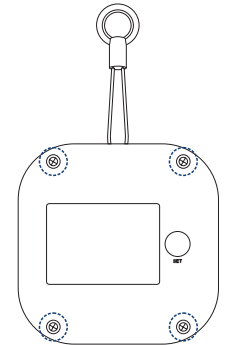

- 3 Remove the two old batteries

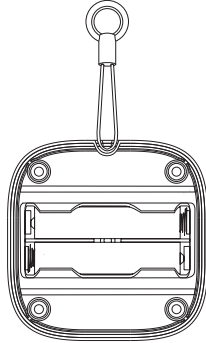

- 4 Install two new AAA batteries

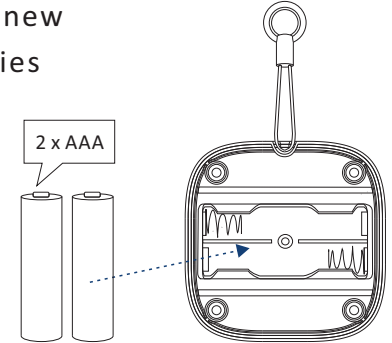

- 5 Close and secure the base by reinstalling and tightening the four screws

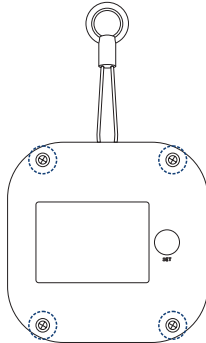

- 6 Reattach the four sealing rubber pads

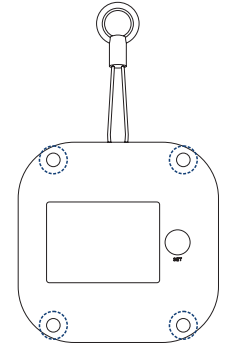

F. Specifications

Voltage: 3V DC (2 - lithium non-rechargeable AAA batteries)

Device Current Draw: $\leq 135\text{mA}$ (operating), $\leq 35\mu\text{A}$ (standby)

Sensor Types: Temperature, Humidity

Temperature Value Accuracy: 0.1 ($^{\circ}\text{F}/^{\circ}\text{C}$)

Humidity Value Accuracy: 0.1%

Alert Temperature: -22°F - 158°F (-30°C - 70°C)

Alert Humidity: 0% - 100%

IP Rating: IP67

Dimensions: 2.44 x 2.44 x 0.87 inches (62 x 62 x 22 millimeters) (L x W x D)

**Temperature Error
(Typical):**

-40°F - 14°F, $\pm 1.44^\circ\text{F}$ (-40°C - -10°C, $\pm 0.8^\circ\text{C}$)
14°F - 41°F, $\pm 0.72^\circ\text{F}$ (-10°C - 5°C, $\pm 0.4^\circ\text{C}$)
41°F - 140°F, $\pm 0.36^\circ\text{F}$ (5°C - 60°C, $\pm 0.2^\circ\text{C}$)
140°F - 176°F, $\pm 0.72^\circ\text{F}$ (60°C - 80°C, $\pm 0.4^\circ\text{C}$)

**Temperature Error
(Maximum):**

-40°F - -4°F, $\pm 2.7^\circ\text{F}$ (-40°C - -20°C, $\pm 1.5^\circ\text{C}$)
-4°F - 32°F, $\pm 1.8^\circ\text{F}$ (-20°C - 0°C, $\pm 1^\circ\text{C}$)
32°F - 41°F, $\pm 0.9^\circ\text{F}$ (0°C - 5°C, $\pm 0.5^\circ\text{C}$)
41°F - 140°F, $\pm 0.72^\circ\text{F}$ (5°C - 60°C, $\pm 0.4^\circ\text{C}$)
140°F - 176°F, $\pm 1.35^\circ\text{F}$ (60°C - 80°C, $\pm 0.75^\circ\text{C}$)

**Humidity Error
(Typical,
@77°F (@25°C)):**

0% - 20% / 80% - 100%, $\pm 3.5\%$
20% - 80%, $\pm 2\%$

**Humidity Error
(Maximum,
@77°F (@25°C)):**

0% - 20% / 80% - 100%, $\pm 7\%$
20% - 80%, $\pm 3.5\%$

Environment:

Working Temperature: -22°F - 158°F (-30°C - 70°C)
Working Humidity: $\leq 95\%$ (non-condensing)

G. Troubleshooting

Symptoms:

1. Device is offline.

- If sensor is not connected to the cloud, press the SET button on the Weatherproof Temperature & Humidity sensor once
- If Hub is offline, reconnect the Hub to the Internet and press the SET button on the Weatherproof Temperature & Humidity sensor once
- If Hub is not on, power on the Hub again and press the SET button on the Weatherproof Temperature & Humidity sensor once
- If sensor is out of range with Hub, relocating the sensor or Hub may be required
- For a device with low-battery indicators or alerts or if the condition of the batteries is in question, replace the batteries with two premium “AAA” lithium batteries

2. Receive notifications out of the alert range: Alert settings are not saved. Refer to "Details page" section on page 9

3. Other issues, contact customer service, **1-949-825-5958 (M-F 9am - 5pm PST)** or email 24/7 at **service@yosmart.com**

H. Warning

- Please install, operate and maintain the Weatherproof Temperature & Humidity Sensor only as outlined in this manual. Improper use may damage the unit and/or void the warranty
- Use only new, name brand, lithium non-rechargeable AAA batteries
- Do not use rechargeable batteries
- Do not use zinc blend batteries
- Do not mix new and old batteries
- Do not puncture or damage batteries. Leakage can cause harm on skin contact, and is toxic if ingested
- Do not dispose of batteries in fire as they may explode! Please follow local battery disposal procedures
- While the sensor is waterproof, to ensure optimal operation and lifetime of the sensor, installing the sensor with overhead protection from weather is suggested. Do not immerse the sensor or allow it to be immersed in water
- Do not install or use this device outside of the temperature and humidity range listed in the Environmental section in Specifications, on page 18
- Do not obstruct the opening on the housing
- Do not install or use this device where it will be subjected to high temperatures and/or open flame

- Install or use this device only in clean environments. Extremely dusty or dirty environments may prevent the proper operation of this device, and will void the warranty
- If your Weatherproof Temperature & Humidity Sensor does get dirty, please clean it by wiping it down with a clean, dry cloth. Do not use strong chemicals or detergents, which may discolor or damage the exterior and/or damage the electronics, voiding the warranty
- Do not install or use this device where it will be subjected to physical impacts and/or strong vibration. Physical damage is not covered by the warranty
- Please contact Customer Service before attempting to repair disassemble or modify the device, any of which can void the warranty and permanently damage the device

If you have any difficulties installing or using your Weatherproof Temperature & Humidity Sensor, please contact our Customer Service department during business hours:

US Live Tech Support: **1-949-825-5958** M-F 9am - 5pm PST

Email: **service@yosmart.com**

YoSmart Inc. 17165 Von Karman Avenue, Suite 105, Irvine, CA 92614

Warranty 2 Year Limited Electrical Warranty

YoSmart warrants to the original residential user of this product that it will be free from defects in materials and workmanship, under normal use, for 2 years from the date of purchase. User must provide a copy of original purchase receipt. This warranty **does not cover** abuse or misused products or products used in commercial applications. This warranty does not apply to Weatherproof Temperature & Humidity sensors that have been improperly installed, modified, put to a use other than designed, or subjected to acts of God (such as floods, lightning, earthquakes, etc.). This warranty is limited to repair or replacement of the Weatherproof Temperature & Humidity sensor only at YoSmart's sole discretion. YoSmart will NOT be liable for the cost of installing, removing, nor reinstalling this product, nor direct, indirect, or consequential damages to persons or property resulting from the use of this product. This warranty only covers the cost of replacement parts or replacement units, it does not cover shipping & handling fees

To implement this warranty please give us a call during business hours at 1-949-825-5958, or visit www.yolink.net

FCC Statement

This equipment has been tested and found to comply with the limits for a Class B digital device, pursuant to part 15 of the FCC Rules. These limits are designed to provide reasonable protection against harmful interference in a residential installation. This equipment generates, uses and can radiate radio frequency energy and, if not installed and used in accordance with the instructions, may cause harmful interference to radio communications. However, there is no guarantee that interference will not occur in a particular installation. If this equipment does cause harmful interference to radio or television reception, which can be determined by turning the equipment off and on, the user is encouraged to try to correct the interference by one or more of the following measures:

- Reorient or relocate the receiving antenna
- Increase the separation between the equipment and receiver
- Connect the equipment into an outlet on a circuit different from that to which the receiver is connected
- Consult the dealer or an experienced radio / TV technician for help

This device complies with part 15 of the FCC Rules. Operation is subject to the following two conditions:

- 1) This device may not cause harmful interference
- 2) This device must accept any interference received, including interference that may cause undesired operation. Any changes or modifications not expressly approved by the party responsible for compliance could void the user's authority to operate the equipment

Note: The manufacturer is not responsible for any radio or TV interference caused by unauthorized modifications to this equipment. Such modifications could void the user's authority to operate the equipment

FCC RF Radiation Exposure Statement

This equipment complies with FCC RF radiation exposure limits set forth for an uncontrolled environment. This device and its antenna must not be co-located or operating in conjunction with any other antenna or transmitter