

YOLINK

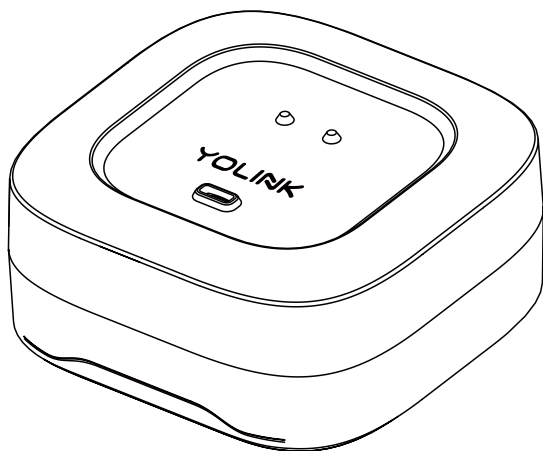

Water Leak Sensor 4

YS7906-UC



Installation & User Guide

Revision Jun. 07, 2023

Contents

A . Welcome!	01
B . Before You Begin	02
C . In the Box	03
D . Get to Know Your Water Leak Sensor 4	03
E . Power Up	04
F . Install the App	05
G . Add Your Fob to the App	06
H . What Can I Do With My WL Sensor 4	08
<hr/>	
I . Install the Water Leak Sensor 4	10
J . Introduction to WLS 4 App Settings	14
K . WLS 4 Settings: Device Control	16
L . WLS 4 Settings: Home Assistant	18
M . WLS 4 Settings: Scenes	19
N . WLS 4 Settings: Alarm Strategies	20
O . WLS 4 Settings: Notifications	21
P . WLS 4 Settings: Alexa	22
Q . WLS 4 Settings: IFTTT	23
<hr/>	
R . Control-D2D Device-to-Device Pairing	25
S . Unpairing	28
T . Battery Replacement	29
U . Specifications	32
V . Factory Reset	33
W . Firmware Updates	34
X . Troubleshooting	35
Y . Warnings	36
Z . Warranty	37
AA. FCC Statement	38
AB. Contact Us	40

A Welcome!

Thank you for purchasing YoLink products! We appreciate you trusting YoLink for your smart home & automation needs. Your 100% satisfaction is our goal. If you experience any problems with your installation, with our products or if you have any questions that this manual does not answer, please contact us right away. See the Contact Us section for more info.

Thank you!

Eric Vanzo
Customer Experience Manager

User Guide Conventions

The following icons are used in this guide to convey specific types of information:



Very important information
(can save you time!)



Good to know info but may not
apply to you

B Before You Begin

Visit our Water Leak Sensor 4 support page on our website, for the latest installation guides, additional resources, information and videos by visiting:

www.shop.yosmart.com/pages/water-leak-sensor-4-product-support

Or by scanning the QR code:



Download the most current version of the user guide by scanning the QR code:



Your Water Leak Sensor 4 connects to the internet via a YoLink hub (SpeakerHub or the original YoLink Hub), and it does not connect directly to your WiFi or local network. In order for remote access to the device from the app, and for full functionality, a hub is required.

This guide assumes the YoLink app has been installed on your smartphone, and a YoLink hub is installed and online (or your location, apartment, condo, etcetera, is already served by a YoLink wireless network).

C In the Box



Water Leak Sensor 4

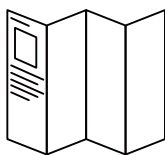

Quick Start Guide

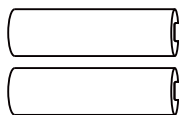

AAA Batteries (2) Installed

D Get to Know Your Water Leak Sensor 4

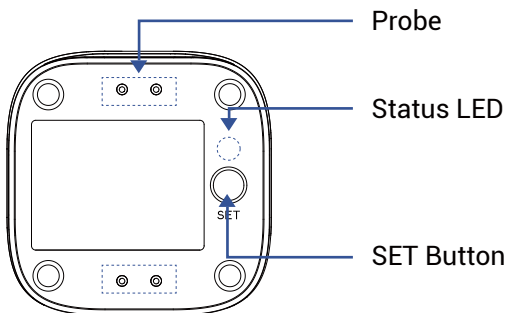
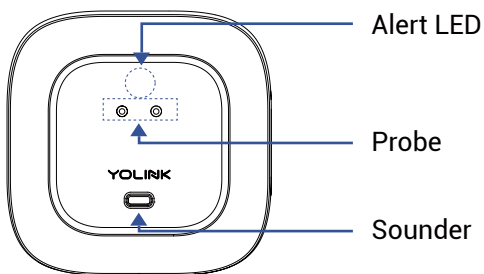

D

Get to Know Your Water Leak Sensor 4, Continued

LED & Beep Behaviors



Blinking Red Once, then Green Once
Device Start-Up



Fast Blinking Green
Control-D2D Pairing in Progress



Blinking Red And Green Alternately
Restoring to Factory Defaults



Blinking Red Once
Device is connected to the cloud and is functioning normally



Blinking Green
Connecting to Cloud



Fast Blinking Red
Control-D2D Unpairing in Progress



Slow Blinking Green
Updating

Alert LED



Blinking Red Every 5 Seconds
Leak or Flooding Warning



Fast Blinking Red Every 30 Seconds
Batteries are Low; Please Replace the Batteries

E

Power Up

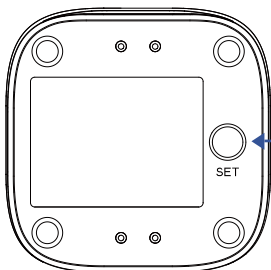

Before you can use your Water Leak Sensor 4, it must be turned on. (Batteries have been pre-installed.) Press the SET button briefly, until the LED flashes red then green (which indicates it has turned on and connected to a hub and the cloud).

F Install the App

If you are new to YoLink, please install the app on your phone or tablet, if you have not already. Otherwise, please proceed to the next section.

Scan the appropriate QR code below or find the “YoLink app” on the appropriate app store.



Apple phone/tablet
iOS 9.0 or higher



Android phone/tablet
4.4 or higher

Open the app and tap **Sign up for an account**. You will be required to provide a username and a password. Follow the instructions, to set up a new account. Allow notifications, when prompted.

You will immediately receive a welcome email from no-reply@yosmart.com with some helpful information. Please mark the yosmart.com domain as safe, to ensure you receive important messages in the future.

Log in to the app using your new username and password.

The app opens to the **Favorite** screen. This is where your favorite devices and scenes will be shown. You can organize your devices by room, in the **Rooms** screen, later.

G

Add Your Water Leak Sensor 4 to the App

1. Tap **Add Device** (if shown) or tap the scanner icon:

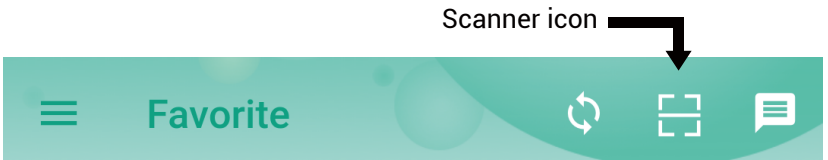

2. Approve access to your phone's camera, if requested. A viewfinder will be shown on the app.

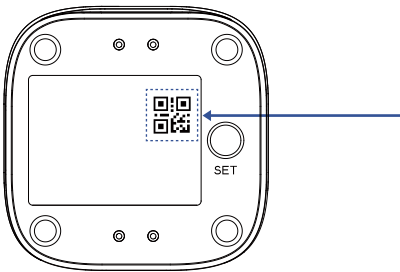

3. Hold the phone over the QR code so that the code appears in the viewfinder. If successful, the **Add Device** screen will be displayed.

G

Add Your Water Leak Sensor 4 to the App, Continued

4. You can change the device name and assign it to a room later. Tap **Bind device**.

5. If successful, the screen will appear as shown. Tap **Done**.

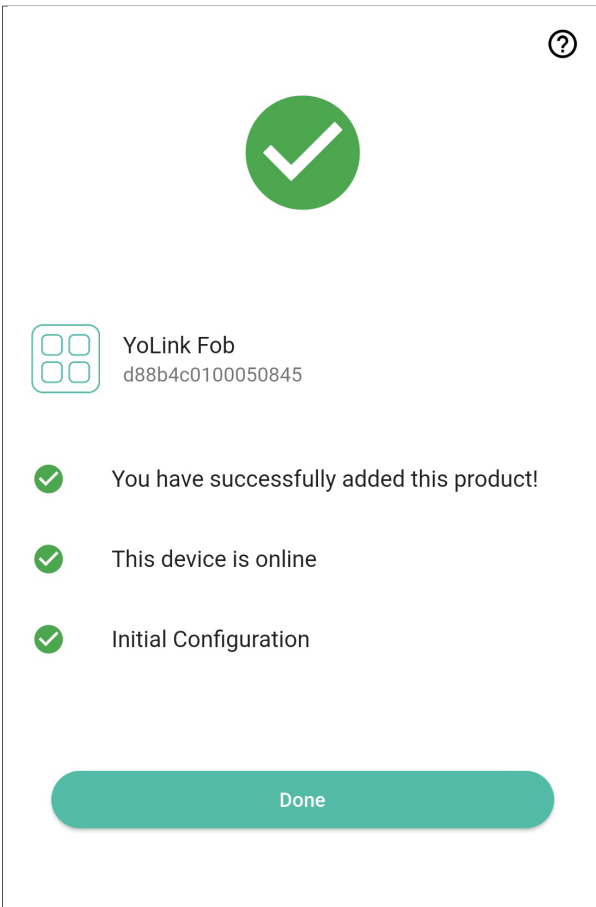



What Can I Do With My Water Leak Sensor 4

Before you begin using your Water Leak Sensor 4, and to get the most out of your purchase, you should be familiar with how the Water Leak Sensor 4's programmable buttons work, and what your Water Leak Sensor 4 can do. The Water Leak Sensor 4 has four programmable, customizable ("flexible") buttons. You operate the buttons by either a short press or a long press, each of which can result in a different response or action. The response/action depends on the programming settings of the button, of course.

In addition to YoLink-specific functions, referred to as "behaviors", (like controlling a YoLink device or scene), the Water Leak Sensor 4 can also be used with third-party applications, including Alexa routines, IFTTT applets, and with Home Assistant (like controlling a Lutron brand light switch or a Roomba robot vacuum cleaner). Please note: the button functions available to these third-party applications are in addition to the YoLink-specific functions (for example, a press of button 1 might control a YoLink smart plug as well as activate an IFTTT routine). For more information on using your Water Leak Sensor 4 with one or more of these third-party applications, refer to page 27.



What Can I Do With My Water Leak Sensor 4, Continued

Place the Water Leak Sensor where a leak or flooding may occur

Suggested Additional Applications :

Basement Floors

Under Laundry Machines

Under Dishwashers

Under Refrigerators (w/Ice Machines)

Near Sump Pumps

Under Fish Tanks/Aquariums

Inside Hot Tubs*

Locations Subject to Freezing Pipes*

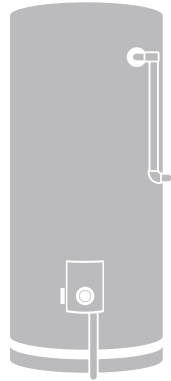

Please refer to device environmental operating range information on page 21. Use this device outside the recommended ranges at your own risk

I Install the Water Leak Sensor 4

Sensor location considerations:

Before placing and setting up your Water Leak Sensor 4, consider the following important factors:

- 1.** The Water Leak Sensor 4 is intended for indoor use, only. It should only be used in indoor environments and within the temperature and humidity ranges as specified in the product listing and product support page on our website.
- 2.** While the Water Leak Sensor 4 is waterproof, it should not be used where it will always be in water or where it may frequently be submerged in water. If water level monitoring is required, consider our Water Level Monitoring Sensor.
- 3.** The Water Leak Sensor 4 has water-sensitive probes or electrodes on both the top and bottom. When water is on or touches any pair of electrodes, this creates an electrical “short circuit” between the electrodes, and the sensor responds with a water leak alert. The top of the sensor is identified by a cupped area with one pair of electrodes. This cupped area is ideal for catching dripping water from above, such as under a sink. The bottom of the sensor has two pairs of electrodes. These are optimized for detecting water that pools or floods below the sensor. (See the next section)



Install the Water Leak Sensor 4, Continued

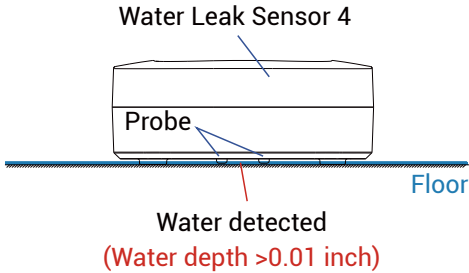

4. Applications for the Water Leak Sensor 4 are many, and they can not be covered in detail in this quick start guide. If you are unsure where to place your Water Leak Sensor 4, please contact us.

5. When determining the location and quantity of sensors required for your applications, consider the types of leaks or flooding that is expected. For example is the water coming from water overflowing, like a sink, toilet, or tub? Is it coming from a leak within an appliance, like a dishwasher? Is it coming from a loose or broken plumbing fitting, like on a laundry machine or ice maker water line? Generally, every location where water goes into or leaves an appliance, where there is a fitting or connection between two pipes, or fixtures, between a hose and a hose connection, and at every faucet or fixture where water comes out, is a potential leak location.



Install the Water Leak Sensor 4, Continued

6. Consider how water may flow and pool or collect if there is a leak at each possible leak location. Consider the slope of the floor or the surface that water may drip onto. A leak at a sink cleanout will result in water directly below the sink, and this water may run towards the front of the vanity or cabinetry or to the back, draining into the base of the cabinetry (only appearing on the floor after a significant leak has occurred). Floors with drains, like in a mechanical room or near a water heater, are intentionally sloped down to the drain. Floors in older homes or where settling has occurred can also result in a slope. Take advantage of any slope in the floor by placing the leak sensor at the bottom of the slope or in the path of the water flowing down the slope. A marble, toy ball, or similar object can be used to check the floor's level, or you may consider pouring a small amount of water on the floor or surface where a leak is possible, to see how the water may flow and pool up.

7. Additional leak sensors can be added if you wish to protect a large region, or you can consider the Water Leak Sensor 2, our rope style leak sensor, that allows for creating larger water detection regions, with the use of additional cables.

8. Avoid locations where the sensor may be moved or disturbed by people or pets. Avoid locations in traffic areas where it may be kicked or stepped on, etc.



Install the Water Leak Sensor 4, Continued

Place the leak sensor

After you have selected a location for the leak sensor, simply place it on the floor or surface, with the cupped part of the sensor facing up.

Test the leak sensor

Functionally test each sensor. A common way to test the Water Leak Sensor 4 is by touching any pair of electrodes with a damp paper towel, but you may find that you can activate the sensor by bridging a pair of electrodes with your thumb or finger. If you choose to pour water on the sensor or on the floor, be sure to fully dry off the sensor after testing. With the app in hand, and the particular leak sensor in view in the app, test your Water Leak Sensor 4.

After the sensor has responded properly (and you've dried it off, if applicable), confirm the sensor is shown to be "Normal" in the app.

J

Introduction to Water Leak Sensor 4 App Settings

In the app, tap on your Water Leak Sensor 4's icon. Your fob's main screen should be similar to the one shown below.

← Water Leak Sensor 4

Tap to exit this screen

Device name

Tap for contact & support resources

Tap for device Details screen

Device battery level icon

Battery Level of Water Leak Sensor - Shown red if battery level is low

Real-time Status of Water Leak Sensor :
Normal or water-detected

Normal

Alert Interval

History

Device Alert History
Water detected and cleared events, logged with date & time

Alert Interval
- Set re-notification interval after a leak or flooding warning Default is 5 minutes

The screenshot shows a mobile app interface for a 'Water Leak Sensor 4'. At the top left is a back arrow and the device name. Below this is a large illustration of the sensor unit on a kitchen counter. To the right of the sensor is a vertical status bar containing a question mark icon, a battery icon, and a Wi-Fi icon. Below the sensor illustration are two circular icons: one showing the sensor with a green status indicator labeled 'Normal', and another showing the sensor with a red status indicator and water splashes. At the bottom of the screen are two buttons: 'Alert Interval' (with a bell icon) and 'History' (with a clock icon). Blue arrows point from text labels to these various UI elements.



Introduction to Water Leak Sensor 4 App Settings

Tap the three dots (in the upper right corner) to open the fobs **Details** screen. Your fob's screen should be similar to the one shown below.

The screenshot shows the 'Details' screen for a Water Leak Sensor 4. The screen is divided into several sections:

- Header:** A teal bar with a back arrow, the title 'Details', and a help icon (question mark in a circle).
- Device Information:**
 - Type:** Water Leak Sensor 4
 - Name:** 79 Leak Sensor >
 - Room:** Office >
 - Favorite:** Will show in favorite screen (with a heart icon)
 - History:** Get device logs >
 - Alarm Strategy:** Default > (with subtext: You will be notified according to selected alarm strategy when device alerts. View your alarm strategies)
 - Alert Interval:** 5 minutes > (with subtext: Continuous Alert Interval)
 - State:** Normal
- Other:** A grey header for the bottom section.
 - Model:** YS7906-UC
 - Device EUI:** d88b4c010004123c
 - SN:** B73768A9E0 (with a QR code)
 - Temperature:** 77 °F
 - Signal Intensity:** Strong (-37 dBm)
 - Battery:** (with a battery level icon)
 - Firmware:** 0313
- Action:** A red button labeled 'Delete' at the bottom.

Callouts on the right side of the image point to the following settings:

- Device Type** (points to the Type field)
- Device Name (Tap to Edit)** (points to the Name field)
- Room (Tap to Edit)** (points to the Room field)
- Favorite (Red if Favorite, Tap to Edit)** (points to the Favorite field)
- Device alarm history (Tap to view device history)** (points to the History field)
- Alarm duration (Siren will automatically silence after this duration)** (points to the Alarm Strategy field)
- Alert Interval** (points to the Alert Interval field)
- State** (points to the State field)
- Model Number** (points to the Model field)
- Device EUI (Unique Identifier Number (Unique))** (points to the Device EUI field)
- Device Serial Number** (points to the SN field)
- Temperature** (points to the Temperature field)
- Signal Intensity (From YoLink Hub)** (points to the Signal Intensity field)
- Battery** (points to the Battery field)
- Firmware Revision (Refer to page 26)** (points to the Firmware field)

Remove Device From Current Account
- Tap to delete the device from your YoLink account



Water Leak Sensor 4 Settings: Device Control

To control one or more YoLink devices, you have several options, including controlling one or more devices by assigning them to one of the buttons via app settings, by activating a scene (that might include taking an action on one or more devices), and by using Control-D2D pairing. This section covers the first method – controlling one or more devices by assigning them to a button via app settings.

The devices you wish to control must have already been bound (added to) your app account. Decide on a button to assign to controlling the device or devices. You can also decide to use one button to turn the device(s) on, and another button to turn them off, or you can use the click (short-press) action to turn them on and the long-press action to turn them off (or vice versa). The steps are very similar.

1. In the app, after deciding on the button to use for the on or off action, open the fob's main screen.
2. Tap **Edit Fob**. The fob button programming screen is displayed
3. Select the appropriate button by tapping 1, 2, 3 or 4 (on the top of the screen). The selected button will have the number underlined.



Water Leak Sensor 4 Settings: Device Control, Continued

4. To use the click/short-press function of the button, tap the + button in that section. Otherwise, tap the + button in the long press section.
5. Tap **Device Actions**. The Choose and Set screen opens.
6. Find and select your first device by tapping on it. Depending on the device type, you will be presented with options such as Lock or Unlock, Turn ON or Turn OFF. Tap the selection that is appropriate for you.
7. Tap the check mark (upper right corner) to confirm your selection.
8. Add additional devices and select their operation as needed. When finished, from the Choose and Set screen, tap the check mark (in the upper right corner).



Water Leak Sensor 4 Settings: Home Assistant

At the time of publication of this user guide, Home Assistant support for the Water Leak Sensor 4 will be included in the next update. Refer to the Home Assistant website and the YoLink integration page for instructions.

Programmers and developers are encouraged to join us on Discord. Sign up here:
<https://shop.yosmart.com/pages/get-connected>



Water Leak Sensor 4 Settings: Scenes

Before you can assign a scene to a button, you must first have created the scene. Here are some simplified instructions for creating a scene:

- 1.** In the app, from the Favorite or Rooms screen, tap the Smart button (on the bottom bar of the app).
- 2.** The Smart screen is displayed. This screen has two parts or tabs, the Scene tab, on the left, and the Automation tab (on the right). The selected or active tab is underlined. If it is not already, tap Scene (near the top).
- 3.** Tap the + button (upper right corner) to create a new scene.
- 4.** Tap the Name region and follow the instructions to name your new scene.
- 5.** You can assign an icon to the scene by tapping in the Icon region.
- 6.** Mark this scene as a favorite by tapping on the favorite (heart) button.
- 7.** You can leave the Group setting as-is, for now.



Water Leak Sensor 4 Settings: Alarm Strategies

You can use your Water Leak Sensor 4 to enable or disable or edit an Alarm Strategy. (It is not in the scope of this user guide to cover Alarm Strategy creation and settings. Please refer to product and app support resources to familiarize yourself with Alarm Strategy settings.)

1. Open the fob's main screen. Tap the **Edit Fob** button.
2. Select the button for this strategy action, and tap the + button on the appropriate button behavior (click/short-press or long-press)
3. Select the **Alarm Strategy** option. Select your strategy, then tap either **Enable Alarm**, **Disable Alarm** or **Advanced Settings**.
4. Tap **Confirm** to approve your selection.
5. Review your settings. Tap the Save button to **save**, or **Cancel** to exit without saving (or you can tap the **Delete** button, or left swipe on the behavior to delete it).



Water Leak Sensor 4 Settings: Notifications

You can actually send yourself or other account members a notification (such as a phone push notification, SMS or email). But you can also, if you have a SpeakerHub, have it play an attention-getting tone, followed by it playing your message via text-to-speech. An example of is a caregiver can be notified if assistance is needed getting out of bed.

In this example, we will create a garage door status checker, that will play a message, only if the door is closed. This will demonstrate the Filter behavior – a behavior that can check the status of a device or scene, before it proceeds to the next behavior.

1. Open the fob's main screen. Tap the **Edit Fob** button.
2. Select the button for this action, and tap the + button on the appropriate button behavior (click/short-press or long-press)
3. Select the **Filter** option. **Tap Set Condition.**
4. Tap **Check Device.** Tap **Continue.**
5. Select your Garage Door Sensor. Tap **Closed.**



Water Leak Sensor 4 Settings: Alexa

You can use the Water Leak Sensor 4 to trigger Alexa routines. You must have the Alexa app installed, the YoLink skill installed and connected to your YoLink app account.

Alexa regards the Water Leak Sensor 4's four buttons as motion sensors. Only the short-press/click button behavior is recognized by Alexa (you can still use the long-press behavior for other things as Alexa ignores it) and in fact, you can still assign a YoLink app function to this button (although you are probably unlikely to need to do this). It is not in the scope of this user guide to cover set up of the Alexa skill or to cover creating an Alexa routine, so the following simplified instructions are provided:

1. Create a new routine in the Alexa app.
2. In the **When This Happens** section, select **Smart Home**.
3. Find your Water Leak Sensor 4. Each button is identified with an "_1, _2, _3, _4" appended to your Water Leak Sensor 4's name. Select the button that you'd like to assign to this routine.
4. Tap the **Detected** button. Disregard the other settings available.
5. Tap **Next**.



Water Leak Sensor 4 Settings: IFTTT

You can use the Water Leak Sensor 4 to trigger IFTTT applets. You must have the IFTTT app installed, the YoLink service installed and connected to your YoLink app account.



Please note, IFTTT.com is a paid service, typically offering 5 free applets.

1. Create a new applet in the IFTTT app.
2. For the If This section, search and select the YoLink service.
3. Tap Flex Fob.
4. In the Device drop-down box, select your Water Leak Sensor 4, tap Done.
5. In the Button drop-down box, select the button. Tap Done.
6. In the Action drop-down box, select either Press or Long Press. Tap Done.
7. Tap Create Trigger to define the applet actions to be assigned to this button.
8. Tap Continue to save your settings.



Water Leak Sensor 4 Settings: IFTTT, Cont.

9. Review your applet settings, if they are correct tap Finish.

Test your new applet by short- or long-pressing on the appropriate Water Leak Sensor 4 button.



Control-D2D Device-to-Device Pairing

YoLink Control-D2D is our unique device to device control technology. Using YoLink Control-D2D, YoLink devices can be controlled without the Hub or an internet connection. (Use of YoLink Control-D2D is optional; you can use the Automation feature in the app OR use YoLink Control, but YoLink Control-D2D offers the benefit of operation without the Hub or internet connection.) One device controls another, directly. A device that sends out commands is called the controller. A device that receives the commands is called the responder. Examples of a controller are a Water Leak Sensor, while examples of a responder are a Siren or the Smart Motorized Valve.

The following instructions uses pairing your Water Leak Sensor 4 with a YoLink SirenFob as example.

1. To configure your Water Leak Sensor 4 as a controller, Press and hold the SET button for 5-10 seconds until the LED quickly blinks green, then, release the button.

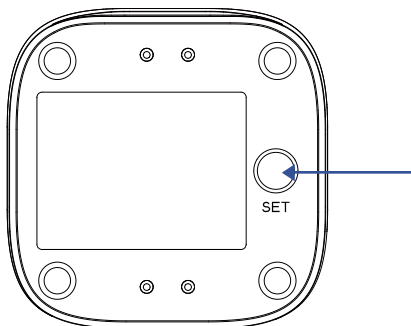

a. SET Button
(5-10 seconds)

R

Control-D2D Device-to-Device Pairing, Continued

2. To configure a Gas/Water Valve Controller as the responder, close the valve using SET button or via YoLink app (verify the valve is shown to be Closed on the app). Press and hold the SET button for 5-10 seconds until the LED quickly blinks green, then, release the button.

b. Press to close the valve

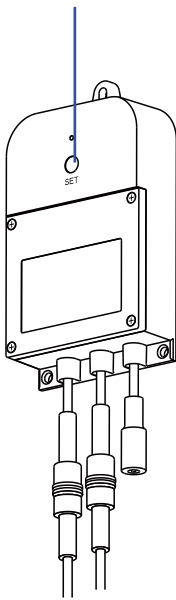

c. SET Button (5-10 seconds)

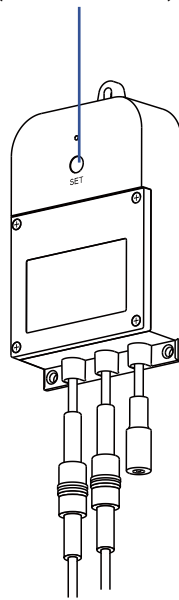

3. Upon pairing, the LED will stop blinking (this may happen after only blinking two or three times).

R

Control-D2D Device-to-Device Pairing, Continued

When the Water Leak Sensor detects water, the YoLink Gas/Water Valve Controller will now immediately close the valve. The valve will remain closed until opened via the app or using the SET button; the restoration of the Water Leak Sensor to normal (no water detected) does not open the valve

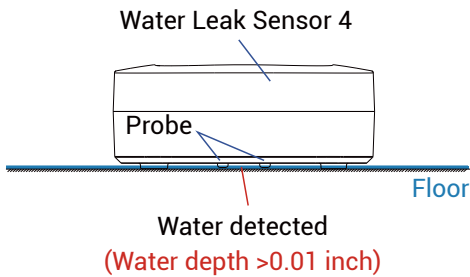

More advanced sequences, controlling multiple outputs (e.g.close valve and activate siren)are available via the YoLink app

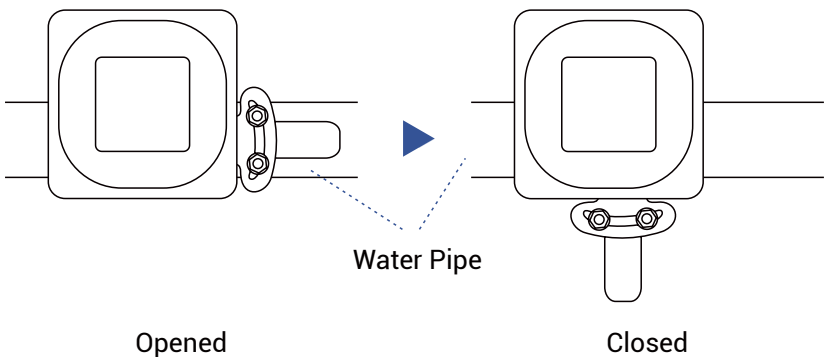

Unpairing

Please visit our website's Support page for the YoLink app guide and for product-specific app settings and instructions:

www.yosmart.com/support-and-service

T Battery Replacement

Tools Required :

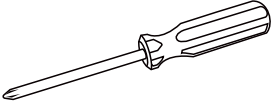

Small Philips Screwdriver

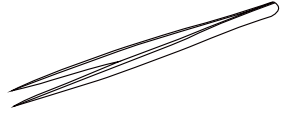

Tweezers



1. To maintain the watertight design of your Water Leak Sensor, use extreme care and follow the battery replacement instructions closely
2. Do not mix old and new batteries
3. Make sure that the bottom shell and sealed rubber pads are tightly secured. Otherwise, the entry of water into the sensor may cause severe damage

T Battery Replacement, Continued

- 1 Use tweezers to take out the four sealed rubber pads at the base of the device

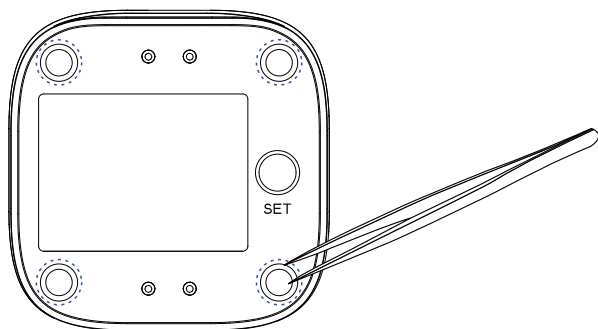

- 2 Use a screwdriver to unscrew the screws at the base of the device and remove the base

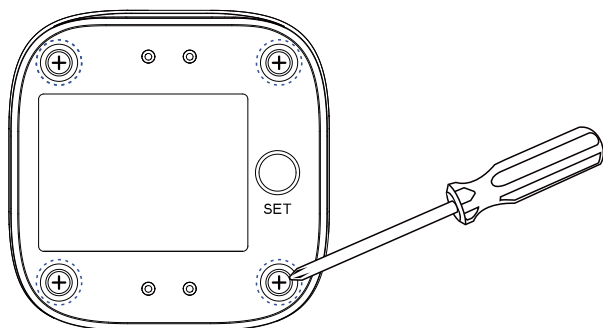

- 3 Remove the two old batteries

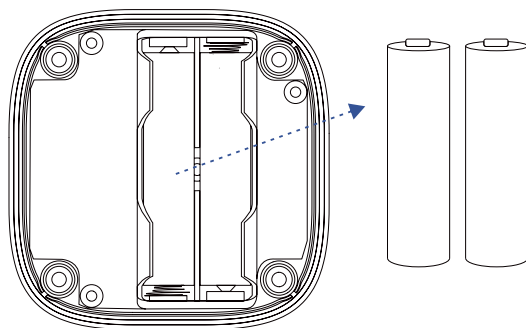

T Battery Replacement, Continued

4 Install two new AAA batteries

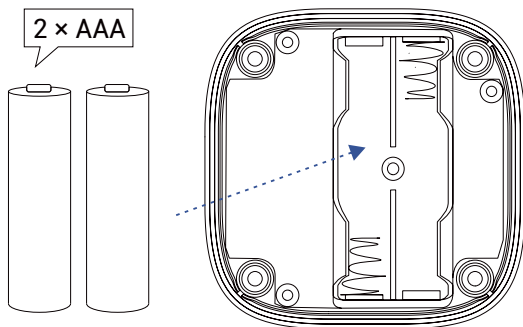

5 Close and secure the base by reinstalling and tightening the four screws

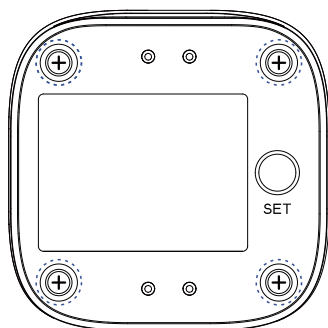

6 Reattach the four sealing rubber pads

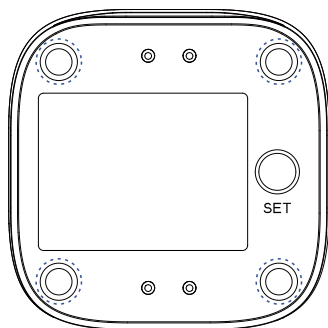



Specifications

Voltage : 3V DC (2 - alkaline non-rechargeable AAA batteries)

IP Rating : IP68

Dimensions : 2.44 × 2.44 × 0.93 inches (62 × 62 × 23.5 millimeters, L×W×D)

Environment : Working Temperature : 32°F - 122°F (0°C - 50°C)
Working Humidity : ≤ 100%RH non-condensing

V Factory Reset

When directed by customer support, and/or as an attempt to resolve a problem with your fob, it may be necessary to perform a factory reset. Factory resetting your fob returns it to the factory default programming and settings. This is a simple process:

- Hold the SET Button for 20 to 30 seconds, until the LED blinks red and green alternately, then release the button.

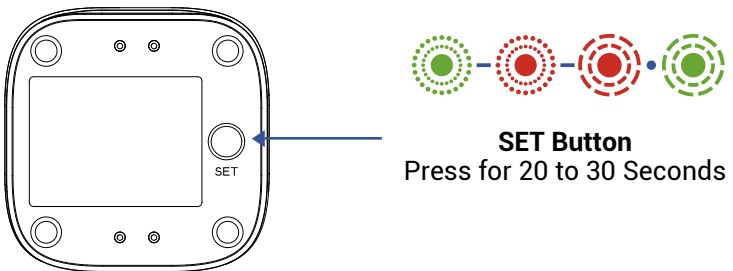

Factory reset is complete when the LED stops flashing.



Pressing the button for longer than 30 seconds will abort the factory reset process.

Factory reset will not remove the fob from the app. The only way to remove the fob from the app is to delete it (in the app).

W Firmware Updates

Your YoLink products are frequently being improved, with new features and functions added over time. It is periodically necessary to make changes to your device firmware. For optimal performance of your device, and to give you access to any improvements made to your device model, these firmware updates should be installed (added to your device) when they become available.

In the Detail screen of your device, you will see the Firmware section, as shown in the image below. A firmware update is available if it says "#### ready now" (where #### is a four-digit combination of letters and/or numbers).

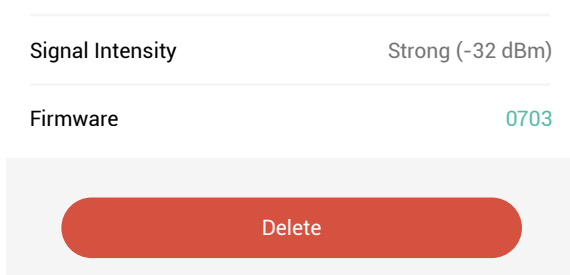

Tap in the Firmware area to start the update. The fob will update automatically, indicating the progress by percentage-complete. You may use your fob during the update process, as the update is performed "in the background". You may see the LED slowly blink green during the update, and the update may continue for several minutes beyond the LED turning off.

Notice: To improve the upgrade successrate , upgrade one device at a time instead of multiple devices at the same time

W Firmware Updates, Continued



Firmware is like settings in your fob that define the overall operations of the fob, for example, determining when and how the fob's sounder should beep. These settings are added to the fob when it is manufactured, and they are periodically updated, as needed, to add improvements, new features, new integrations, etc, to your fob, as they become available. If you use your Water Leak Sensor 4 without an associated YoLink hub, firmware updates can not be made on your fob.

X Troubleshooting

If your fob does not operate as expected, if the fob has worked before, but stopped working, check and replace the batteries, if needed. If the fob has not worked before, perform the pairing process as previously explained, then test the fob again.

If this does not resolve the issue, please contact our customer support department (see the contact info on the last page of this guide).

We recommend checking for and performing any available firmware updates before contacting customer support.

Y Warnings

For optimal performance and lifetime of your fob, please adhere to the following warnings:

The Water Leak Sensor 4 is water-resistant but not waterproof. Do not allow your fob to get wet or be submerged in water or other liquids. Promptly dry off your fob if it does get wet.

- The Water Leak Sensor 4 is intended generally for use in indoor environments or safe from the elements. Do not leave your fob outside and/or where it may be exposed to extreme hot or cold environments. The battery life can be adversely impacted by extreme hot or cold environments. The fob can be harmed by ice, water, or condensing moisture.
- When replacing the batteries, only use new alkaline or lithium non-rechargeable batteries.
- Do not use zinc blend batteries.
- Do not mix old and new batteries.
- Adhere to the battery manufacturer's safety and disposal or recycling instructions.
- If storing your fob unused for extended periods, remove the batteries.
- Please contact Customer Support before attempting to repair, disassemble, or modify your fob, any of which can permanently damage your fob and void the warranty.

2 Year Limited Electrical Warranty

YoSmart Inc. warrants to the original user (“customer”) of this product that it will be free from defects in materials and workmanship, under normal use, for 2 years from the date of purchase. This warranty does not apply to devices that have been improperly installed, modified, put to a use other than designed, or subjected to acts of God (such as floods, lightning, earthquakes, etc.). This warranty does not cover neglected or abused products. This warranty is limited to the repair or replacement of the device, only, at YoSmart's sole discretion. YoSmart will NOT be liable for the cost of installing, removing, nor reinstalling this product, nor direct, indirect, or consequential damages to persons or property resulting from the use of this product. This warranty only covers the cost of replacement parts or replacement units, it does not cover shipping & handling fees. The customer must provide proof of purchase, in the form of the original purchase invoice or order number. The purchase must have been made from an authorized seller.

To implement this warranty please contact us by one of the methods listed on the Contact Us page of this user guide.



FCC Statement

This device complies with part 15 of the FCC Rules. Operation is subject to the following two conditions: (1) This device may not cause harmful interference, and (2) this device must accept any interference received, including interference that may cause undesired operation. Any Changes or modifications not expressly approved by the party responsible for compliance could void the user's authority to operate the equipment.

Note: This equipment has been tested and found to comply with the limits for a Class B digital device, pursuant to part 15 of the FCC Rules. These limits are designed to provide reasonable protection against harmful interference in a residential installation. This equipment generates uses and can radiate radio frequency energy and, if not installed and used in accordance with the instructions, may cause harmful interference to radio communications. However, there is no guarantee that interference will not occur in a particular installation. If this equipment does cause harmful interference to radio or television reception, which can be determined by turning the equipment off and on, the user is encouraged to try to correct the interference by one or more of the following measures:

- Reorient or relocate the receiving antenna.
- Increase the separation between the equipment and receiver.
- Connect the equipment into an outlet on a circuit different from that to which the receiver is connected.



FCC Statement, Continued

- Consult the dealer or an experienced radio/TV technician for help.

To maintain compliance with FCC's RF Exposure guidelines, This equipment should be installed and operated with minimum 20cm distance between the radiator and your body: Use only the supplied antenna.

PRODUCT NAME:
Water Leak Sensor 4

PARTY:
YOSMART, INC.

TELEPHONE:
831-292-4831

MODEL NUMBER:
YS7906-UC

ADDRESS:
15375 BARRANCA PKWY SUITE J-107, IRVINE,
CA 92618 USA

EMAIL:
SERVICE@YOSMART.COM



Contact Us

We are here for you, if you ever need any assistance installing, setting up or using a YoLink app or product!

Need help? For fastest service, please email us 24/7 at service@yosmart.com

Or call us at **831-292-4831** (US phone support hours: **Monday - Friday, 9AM to 5PM Pacific**)

You can also find additional support and ways to contact us at:

www.yosmart.com/support-and-service

Or scan the QR code:



Support Home Page

Finally, if you have any feedback or suggestions for us, please email us at feedback@yosmart.com

Thank you for trusting YoLink!

Eric Vanzo
Customer Experience Manager

YOLINK

15375 Barranca Parkway Ste. J-107 | Irvine, California 92618
© 2023 YOSMART, INC IRVINE, CALIFORNIA