

Outdoor Alarm Controller 2

YS7107-UC



TABLE OF CONTENTS

A . Welcome	01
B . Before You Begin	02
C . Included	03
D . Required Items	04
E . Get To Know Your Alarm Controller 2	05
<hr/>	
F . Power Up	06
G . Install The App	07
H . Add Your Alarm Controller 2 To The App	08
I . Get to Know Your Siren Horn	10
J . Installation	11
<hr/>	
K . Operation	15
L . App Settings	17
M . Control-D2D	22
N . 3rd-party Integrations	24
O . Replacing The Batteries	25
<hr/>	
P . Specifications	27
Q . Factory Reset	28
R . Firmware Update	29
S . Troubleshooting	30
T . Warnings	32
<hr/>	
U . Warranty	34
V . FCC Statement	35
W . Contact Us	37

A Welcome!

Thank you for purchasing YoLink products! We appreciate you trusting YoLink for your smart home & automation needs. Your 100% satisfaction is our goal. If you experience any problems with your installation, with our products or if you have any questions that this manual does not answer, please contact us right away. See the Contact Us section for more info.

Thank you!

Eric Vanzo
Customer Experience Manager

User Guide Conventions

The following icons are used in this guide to convey specific types of information:



Very important information
(can save you time!)



Good to know info but may not
apply to you

B

Before You Begin

Visit our Outdoor Alarm Controller 2 support page on our website, for the latest installation guides, additional resources, information and videos by visiting:

<https://shop.yosmart.com/pages/outdoor-alarm-controller-2-product-support>

Or by scanning the QR code:



Download the most current version of the user guide by scanning the QR code:



Your Outdoor Alarm Controller 2 wirelessly connects to the internet via a YoLink Hub or SpeakerHub, and it does not directly connect to your WiFi or local network. In order for remote access to the device from the app, and for full-functionality, a YoLink hub is required. This guide assumes the YoLink app has been installed on your phone, and a YoLink Hub or SpeakerHub is installed and online.

C Included

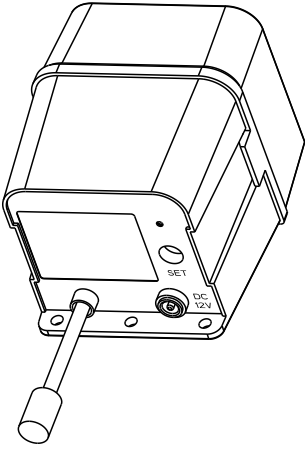

Outdoor Alarm Controller 2

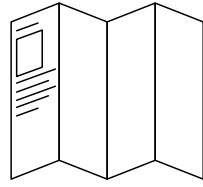

Quick Start Guide

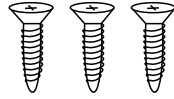

Phillips Head Screws(3)

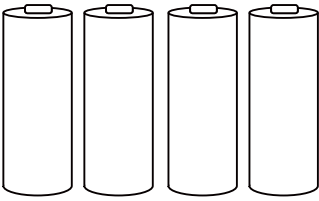

4 x C Batteries (Pre-Installed)

Your kit may include a siren:

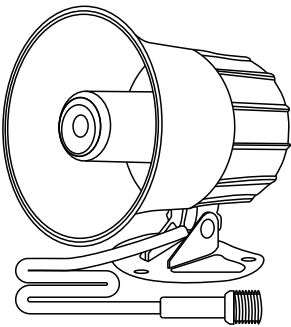

Siren Horn ES626

OR

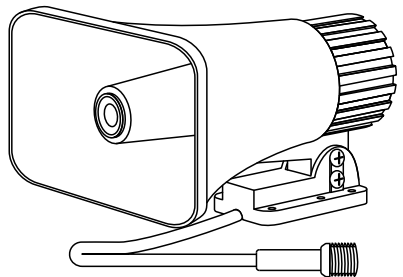

Siren Horn ES711

D Required Items

These tools or items may be required:

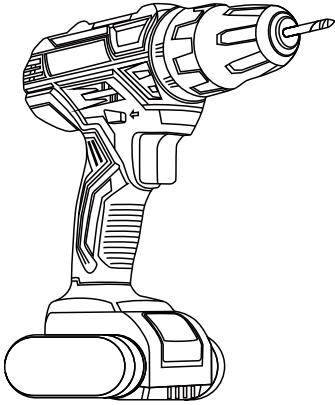

Drill with Drill Bits

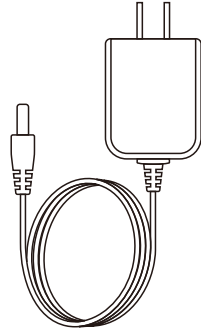

AC/DC Adapter or
12VDC Power Supply

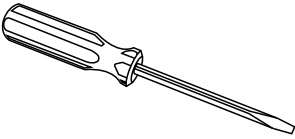

Extra Small Straight Screwdriver

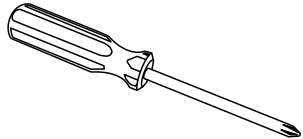

Medium Phillips Screwdriver

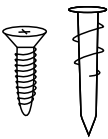







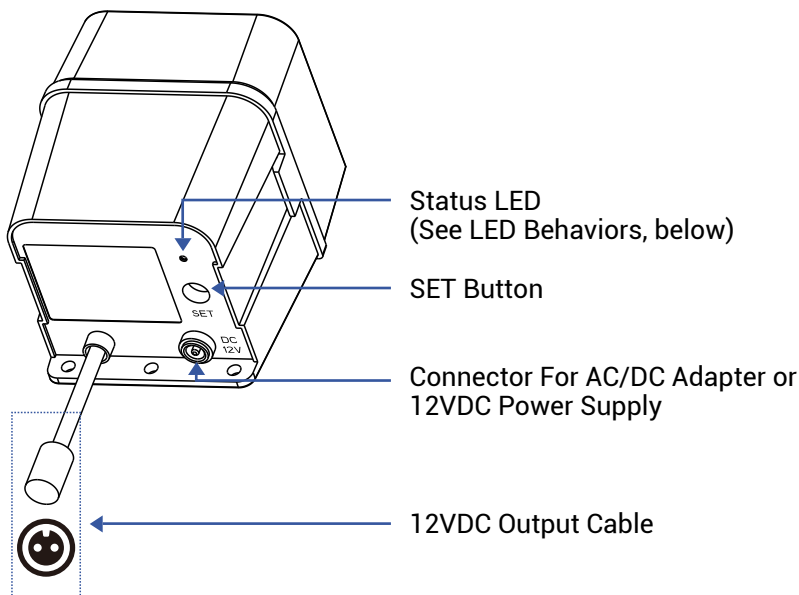

Wall Anchors

E

Get to Know Your Outdoor Alarm Controller 2



LED Behaviors

-  **Blinking Red Once, Then Green Once**
Device Start-Up
-  **Blinking Red And Green Alternately**
Restoring to Factory Defaults
-  **Slow Blinking Green**
Updating
-  **Fast Blinking Green**
Control-D2D Pairing in Progress
-  **Steady Green**
DC power is applied
-  **Blinking Red Once**
Siren or Output Activated (on battery power)
-  **Blinking Red Continuously**
Siren or Output Activated (on external power)
-  **Fast Blinking Red**
Control-D2D Unpairing in Progress
-  **Fast Blinking Red Once Every 30 Seconds**
Low Battery, Replace Battery Soon

F Power Up

Power up the Valve Controller 2 by briefly pressing the SET button, until the LED flashes (red, then green).

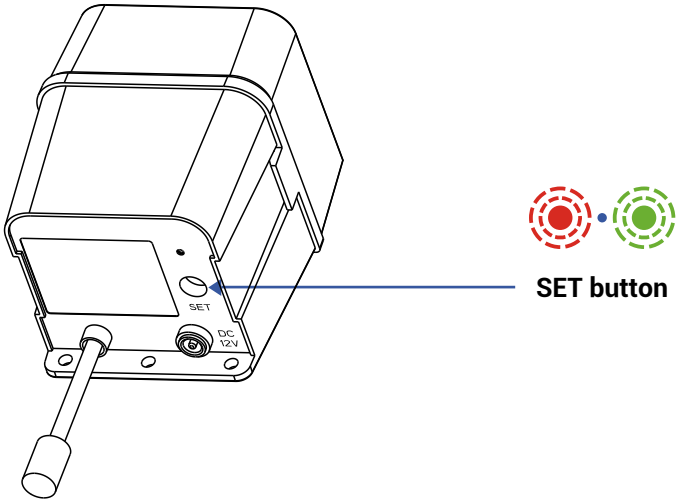

G Install the App

If you are new to YoLink, please install the app on your phone or tablet, if you have not already. Otherwise, please proceed to the next section.

Scan the appropriate QR code below or find the “YoLink app” on the appropriate app store.



Apple phone/tablet
iOS 9.0 or higher



Android phone/tablet
4.4 or higher

Open the app and tap **Sign up for an account**. You will be required to provide a username and a password. Follow the instructions, to set up a new account. Allow notifications, when prompted.

You will immediately receive a welcome email from no-reply@yosmart.com with some helpful information. Please mark the yosmart.com domain as safe, to ensure you receive important messages in the future.

Log in to the app using your new username and password.

The app opens to the **Favorite** screen. This is where your favorite devices and scenes will be shown. You can organize your devices by room, in the **Rooms** screen, later.



Add Your Alarm Controller 2 to the App

1. Tap **Add Device** (if shown) or tap the scanner icon:

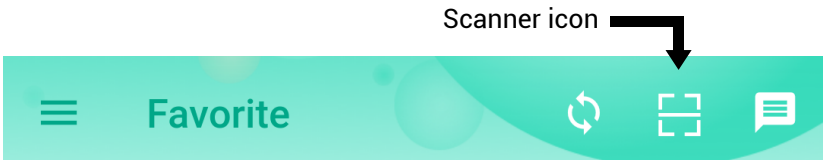

2. Approve access to your phone's camera, if requested. A viewfinder will be shown on the app.

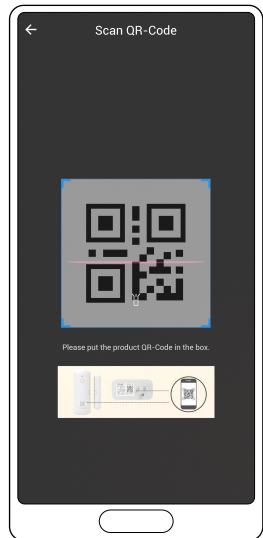
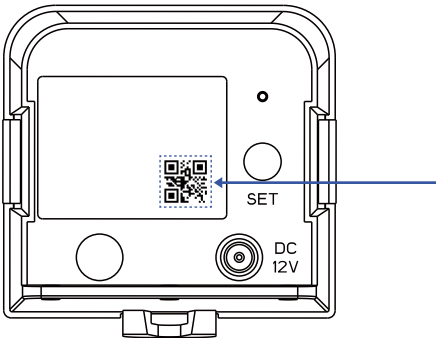

3. Hold the phone over the QR code so that the code appears in the viewfinder. If successful, the **Add Device** screen will be displayed.



Add Your Alarm Controller 2 to the App, Continued

4. You can change the device name and assign it to a room later. Tap **Bind device**.

5. If successful, the screen will appear as shown. Tap **Done**.

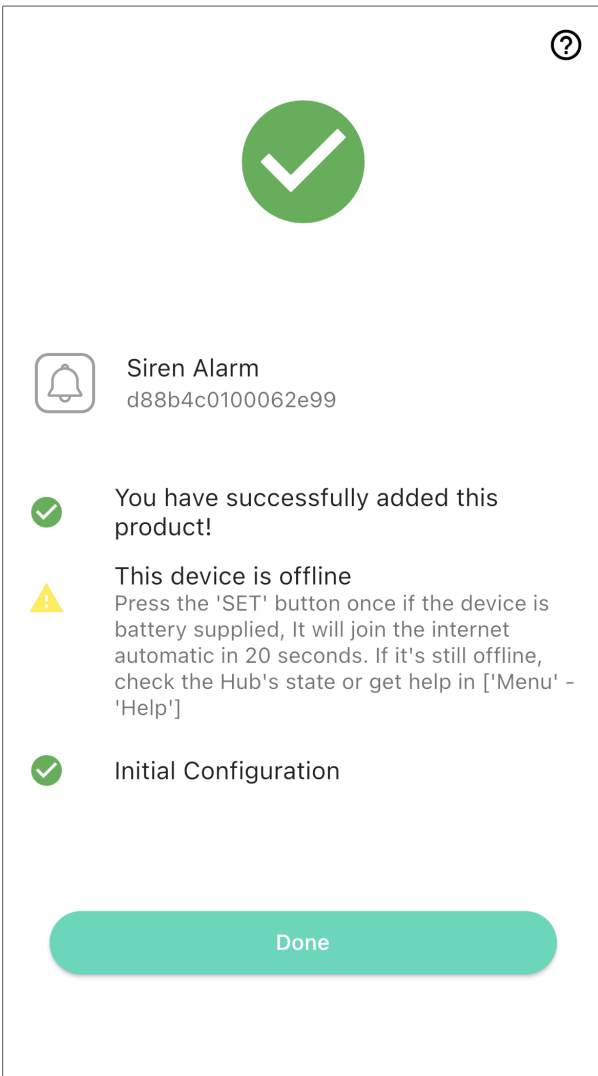

I Get to know your Siren Horn

Siren Horn ES626:

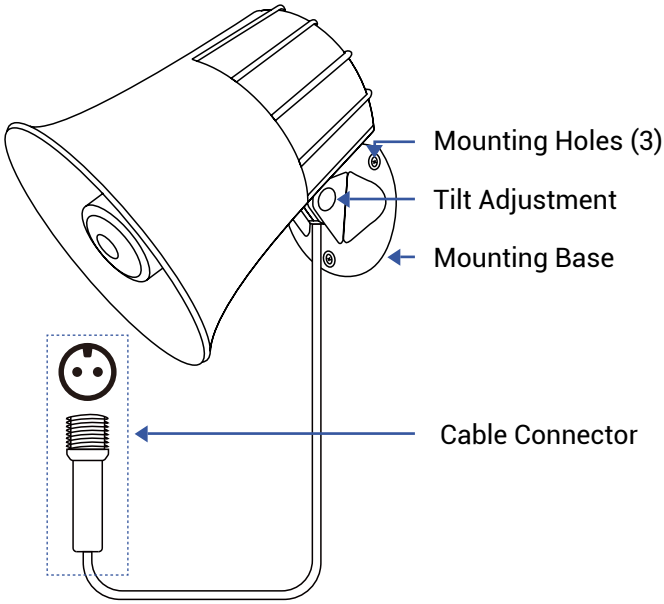

Siren Horn ES711:

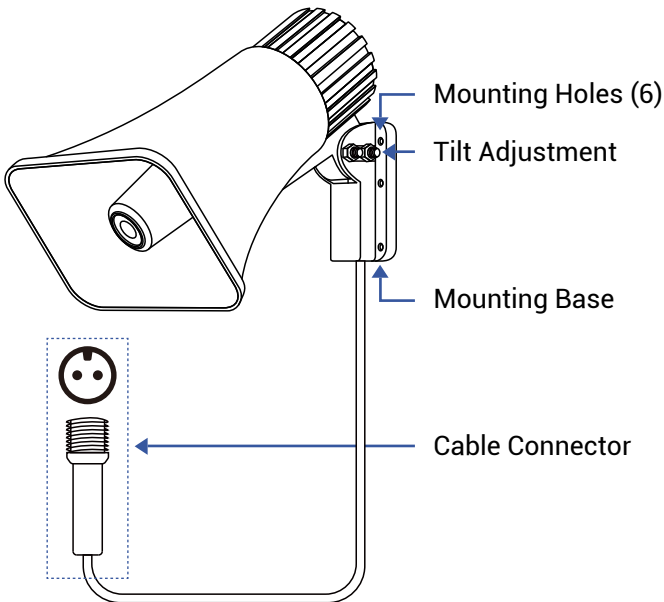

J Installation

Preparing for Installation

Determine where you will install your Outdoor Alarm Controller 2 and Siren. Typically, they will be mounted together, no farther apart from each other than the cables allow. (Extension cables are available, allowing for locating the siren remotely from the controller)

Note: use of the 12VDC power adapter is optional. If not used, batteries are required. If the power adapter is used, batteries are optional.

Determine how you will mount the controller and siren, and have appropriate mounting hardware (screws, anchors, etc.) and a means of installing them in the wall or mounting surface on hand.

It is important to securely mount the Outdoor Alarm Controller and the Siren to the wall or mounting surface, to ensure they do not later fall down. Physical damage to the device is not covered by the warranty.

Consider if the controller or siren will be subjected to tampering or vandalism. Mounting them higher on the wall may deter tampering.

Also, consider minimum mounting heights. As the siren is very loud, you should avoid locating it near head height or at locations where people may be present when it activates. Hearing can be damaged by high decibel sounds, such as the siren produces.

J Installation, Continued

While the controller and siren are designed for outdoor use, as with any electronic or similar device, protecting it from direct intense sunlight and from rain or snow with overhead cover, can extend its life and protect it from issues like fading colors or dry and brittle cables or plastic. Just under the eaves of a roof or under an overhanging structure is an ideal location for this product.

Pro tip: like the professional installers may do, you can consider installing your siren in the attic, if applicable. A location in the attic may allow for sound to be carried both inside the home as well as outside (depending on siren proximity to eaves or gable vents and the construction characteristics of your home).

You may consider testing the siren at the proposed location before permanently installing it, checking that the sound carries as far as desired.

Additional Alarm Controllers and Sirens can be added to your system, and may be required for larger homes or buildings, and larger yards or locations with sound obstructions and/or high ambient sound levels.

J Installation, Continued



If you are using the Outdoor Alarm Controller 2 with a 12V DC device other than the included siren, such as a strobe or relay, please note the following:

- The device must be 12V DC, not AC, not less or more than 12 volts.
- The device current draw and inrush current must be under 1 ampere.
- Correct polarity must be observed.
- Do not attempt to power the device for extended periods, as this will quickly drain the battery.
- If you will not be using your Outdoor Alarm Controller 2 with an external 12VDC power source, consider using the controller to power a low-current 12VDC relay or mechanically-latching relay, with the load being powered by a separate power source.

J Installation, Continued

Install the Siren

1. Holding the siren at the desired location, transfer the location of the mounting holes to the wall or mounting surface, using a marker or similar means.

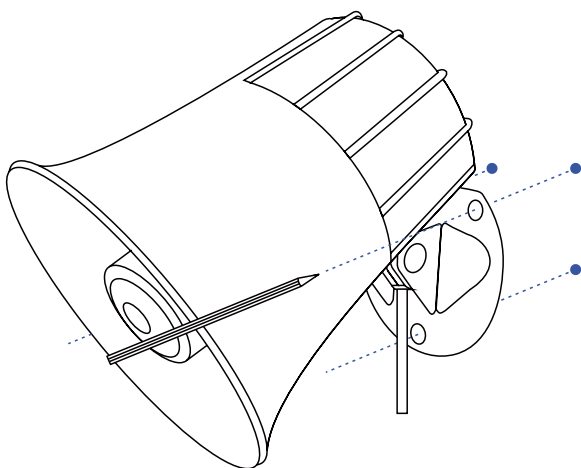

2. If you are using wall anchors, install them per the manufacturer instructions (this may require a drill and appropriate drill bit).

3. You can adjust the desired up/down tilt of the siren at this time or during testing.

J Installation, Continued

Install the Outdoor Alarm Controller 2

1. At the desired location for the controller, confirm the cables of the two devices will reach each other. Holding the controller at the desired location, mark the location of the mounting holes to the wall or mounting surface, using a marker or similar means.
2. If you are using wall anchors, install them per the manufacturer instructions.
3. Secure the Alarm Controller to the wall or mounting surface with screws, as shown.

K Operation

1. Connect the cable of the controller to the cable of the siren. Ensure the arrow of the cable connector aligns with the arrow of the other cable connector. Twist the collar of the connector tight.

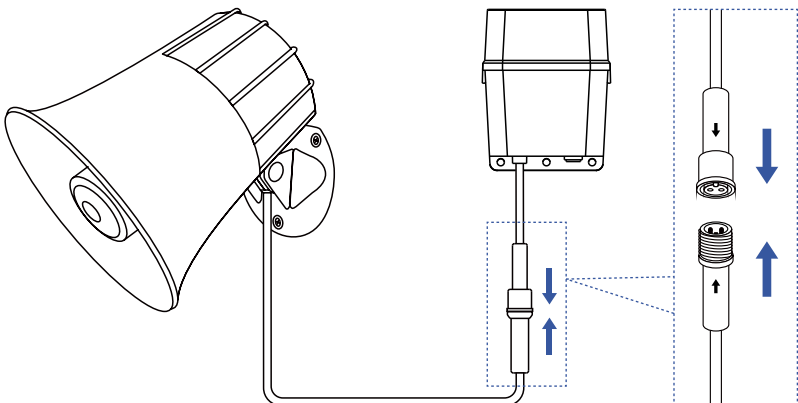

K Operation, Continued

2. If using an external 12V DC power supply, connect the cable to the controller at this time. With the power source off or unplugged, connect the cable of the 12V DC power adapter or power supply to the 12V DC input of the alarm controller.
3. If applicable, turn on the 12V DC power supply or connect the power adapter to AC power at this time.
4. Test the siren by pressing the SET button on the controller. The siren should activate. Press the SET button again to silence the siren.



Protect your ears and those of others that may be close to the siren during testing. Consider warning your neighbors you will be testing your siren, to avoid a surprise visit from the police department!

L App Settings

In the app, tap on your Alarm Controller 2 icon. Your main screen should be similar to the one shown below.

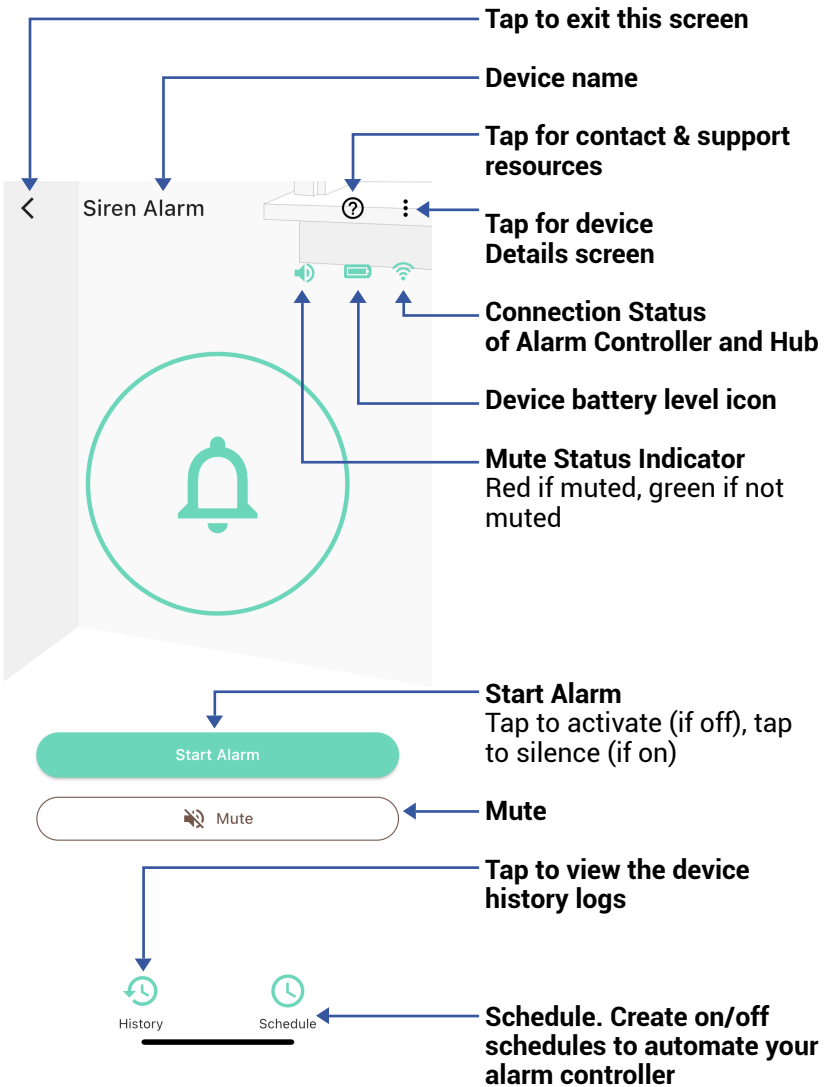

About the Mute Feature:

The Mute feature allows you to disable or prevent your siren (or connected device) from operating while muted. The Mute feature has a Mute Duration setting. This duration determines how long the alarm controller will be muted, until it automatically unmutes (returns to normal operation). The default for this setting is two hours. It can be set between 5 minutes to 24 hours.

A related setting is the Alarm Duration setting. The Alarm Duration setting determines how long your alarm controller will stay on, before automatically silencing/deactivating. This duration has a default setting of 30 seconds, which can be changed to between 5 seconds and 4 hours. Or, it can be set to "Forever", in which case it will not automatically silence. The Alarm Duration is beneficial for conserving the batteries by automatically turning off after your defined duration (after which the purpose of the alarm should have been accomplished, such as scaring off an intruder, notifying you of a water leak, etc.), and to avoid it becoming a nuisance alarm to others. The alarm controller will not activate the siren/output while muted, regardless of the activation method (pressing Start Alarm in the app, activating it from a fob, Control-D2D-paired device activation, Alexa and so on), but it is important to be aware that if your Alarm Duration is longer than your Mute Duration, the siren/output will activate after the Mute Duration expires.

L App Settings, Continued

And, if the alarm controller has been activated while Muted, and you unmute it before pressing Stop Alarm, the siren will sound (the output will activate).

You can use the Mute feature to essentially “arm” or “disarm” security devices that have been paired to your siren. If you have, for example, paired motion and vibration sensors in your vehicle, RV, boat, etcetera, then you can mute the siren(s) while you are using the vehicle, and unmute them while it is not in use.



If you use a SirenFob with your Alarm Controller 2, the unlocked padlock button mutes the controller, while the locked padlock button acts as the Unmute button.

L App Settings, Continued

Tap the three dots (in the upper right corner) to open the fob's **Details** screen. Your fob's screen should be similar to the one shown below.

Device Type

Device Name
(Tap to Edit)

Room
(Tap to Edit)

Favorite
(Red if Favorite, Tap to Edit)

Device alarm history
Tap to view device history

Alarm duration
Siren will automatically silence after this duration

Mute duration
Siren can not activate during this period

Time

Battery

Connection status of alarm controller and Hub

Model Number

Device EUI
Unique Identifier Number (Unique)

Device Serial Number

Signal Intensity
(From YoLink Hub)

Firmware Revision
(Refer to page 26)

Remove Device From Current Account
- Tap to delete the device from your YoLink account

Setting	Value
Type	Siren Alarm
Name	Siren Alarm >
Room	Not Set >
Favorite	Will show in favorite screen
History	Get device logs >
Alarm Duration	30 seconds >
Mute Duration	2 hours >
Time	3/29 19:33:23 (GMT-7) Sync With Mobile >
Battery	[Battery Icon]
State	Online
Model	YS7107-UC
Device EUI	d88b4c0100062e99
SN	970EA82480 [QR Code] >
Signal Intensity	Strong (-27 dBm)
Firmware	0705

M

Control-D2D Device-to-Device Pairing

YoLink Control-D2D is our unique device to device control technology. Using YoLink Control-D2D, YoLink devices can be controlled without the Hub or an internet connection. (Use of YoLink Control-D2D is optional; you can use the Automation feature in the app OR use YoLink Control, but YoLink Control-D2D offers the benefit of operation without the Hub or internet connection.) One device controls another, directly. A device that sends out commands is called the controller. A device that receives the commands is called the responder. Examples of a controller are a Water Leak Sensor, while examples of a responder are a Siren or the Smart Motorized Valve.

The following instructions uses pairing your Outdoor Alarm Controller 2 with a YoLink SirenFob as example.

1. On the SirenFob, press and hold the Siren Activate button for 5 to 10 seconds, until the LED flashes green, then release the button.

Press for 5-10 Seconds

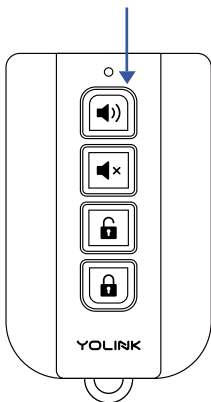

Until the LED Flashes Green

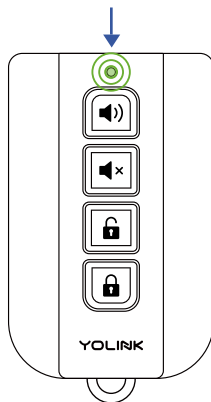

M

Control-D2D Device-to-Device Pairing, Continued

2. On the siren device, press and hold the SET button for 5 to 10 seconds, until the status LED flashes green.

Press for 5-10 Seconds

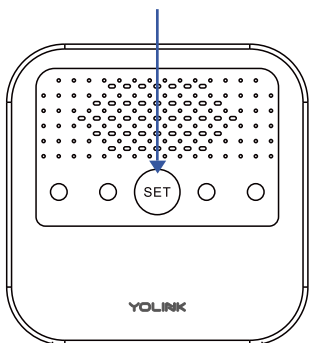

Until the LED Flashes Green

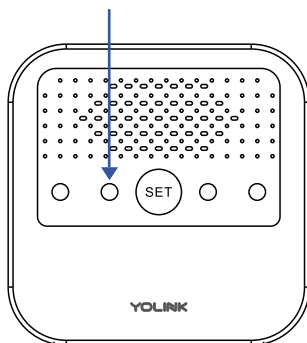

Your SirenFob is now paired to your siren device. Pair additional siren devices, if needed.

Test your SirenFob. Press the Start Alarm to turn on the siren(s), then press the Deactivate Button to silence the siren(s).

The steps to pair your Siren Alarm and/or Outdoor Alarm Controller with YoLink alarm devices is similar. Refer to the associated product's user guide for exact instructions.

After alarm devices have been paired to your siren(s), you can use the Mute/Unmute buttons to prevent or allow them to activate the siren, as explained in the previous section.



Control-D2D Device-to-Device Pairing, Continued

Unpair Your SirenFob:

1. On the SirenFob, press and hold the Start Alarm button for 10 to 15 seconds, until the LED flashes green, then red, then release the button.
2. On the siren device, press and hold the SET button for 10 to 15 seconds, until the status LED flashes green, then red.

The siren device will no longer respond to the SirenFob.



You can pair from 1 to 128 siren devices to your SirenFob!



3rd-Party Services

Please visit our website's Support page for the YoLink app guide and for product-specific app settings and instructions:

www.yosmart.com/support-and-service

0 Replacing The Batteries

To replace the batteries, have four new alkaline or lithium C cell batteries on hand and follow these instructions:

1. If you are using an external power supply, disconnect or turn it off.
2. Remove the cover of the alarm controller, to gain access to the battery compartment. This may be done by hand or with a flat screwdriver or similar object. With a gentle prying and lifting motion, release the two tabs on the cover, and pull it away from the main assembly.

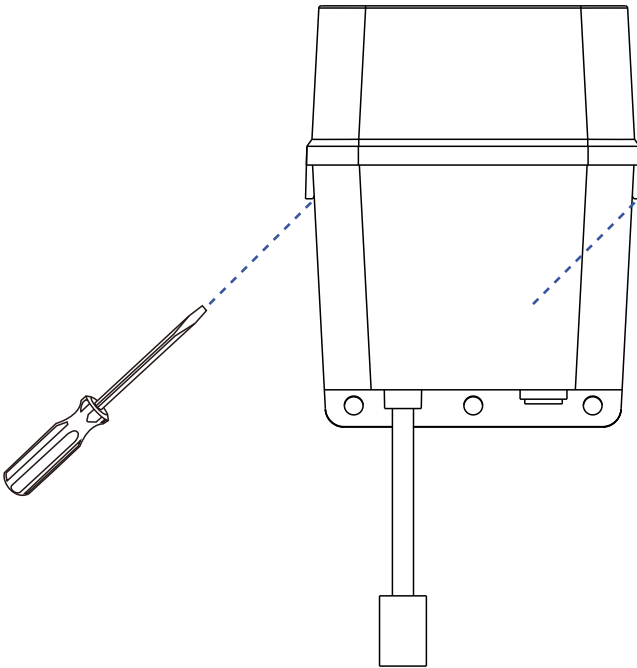

0 Replacing The Batteries, Cont.

3. Observe the polarity indicators on the controller and/or on the batteries themselves. Remove and replace the batteries with the new batteries. Use care to not accidentally mix your new and old batteries; always replace all four batteries with new batteries.

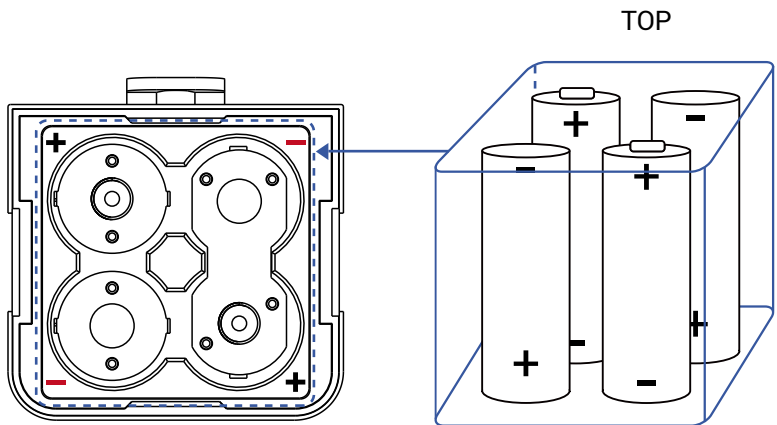

4. To reinstall the cover, align the side tabs of the cover with the slots on main assembly, and press down, snapping it in place. Inspect each side of the controller, to ensure a proper fit.

5. On battery power, only, test your controller by pressing the SET button to activate, then press it again to silence it.

6. Reconnect the 12VDC input cable, if necessary.

7. You can also check the controller in the app, to ensure it is online, and the low-battery indication has cleared.

P Specifications

Battery:	6V DC (four alkaline non-rechargeable C batteries)
Device Current Draw:	≤20mA (On connecting With the siren horn), ≤100uA (Standby)
Output Voltage:	12V DC
Output Current:	≤1Amp (Resistive)
IP Rating:	IP63 (Rainproof)
Siren Horn Type:	12V DC with integral siren driver
Range:	5°C- 30°C
Environment:	Working Temperature: -4°F - 122°F (-20°C- 50C) Working Humidity: 0%-100%

Q Factory Reset

Factory reset will erase device settings and restore it to factory default settings. Doing a factory reset will not remove the device from your account and it will not harm the device, or lose any data or require you to redo your automations, etc.

Instructions:

Hold the SET button down for 20-30 seconds, until the LED blinks red and green alternately. Then, release the button. (Holding the button down longer than 30 seconds will abort the factory reset operation)

Factory reset will be complete when the LED stops blinking.



PLEASE NOTE: Only deleting a device from the app will remove it from your account. Factory reset will not delete the device from the app.

R Firmware Update

Your YoLink products are constantly being improved, with new features added. It is periodically necessary to make changes to your device's firmware. For optimal performance of your system, and to give you access to all available features for your devices, these firmware updates should be installed when they become available.

In the Detail screen of each device, at the bottom, you will see the Firmware section, as shown in the image below. A firmware update is available for your device if it says "#### ready now"

Tap in this area to start the update.

The device will update automatically, indicating progress by percentage-complete. You may use your device during the update, as the update is performed "in the background". The LED will slowly blink green during the update, and the update may continue for several minutes beyond the LED turning off.

S Troubleshooting

These troubleshooting suggestions assume the device has been successfully added to the app. If the device is not working correctly and it is not in the app, return to the Add the Outdoor Alarm Controller to the App section and double-check or re-do these steps.

A. Device can not be operated at all, and can not be operated manually via the SET button:

- 1) Ensure the device is turned on (See Power Up section, if needed).
- 2) Check batteries, verify proper installation.
- 3) Replace the batteries.
- 4) Check cable connectors. Ensure arrows are aligned and the connectors are tightened together.

B. Device can be operated manually, but it is offline

- 1) Ensure the device is connected to the cloud, by pressing the SET button until the LED illuminates briefly.
- 2) Ensure the device is within range of the hub. If you are installing the device remotely from the hub, first place it near the hub to ensure it connects to the cloud via the hub. (Press the SET button briefly to force the device to attempt to reconnect with the cloud). If it is now online, the original location was out of range of the hub. Relocating the device, the hub, or adding an additional hub may be solutions. Contact us as needed for additional guidance.

C. If a Control-D2D-paired functionality is not working:

- 1) Review and re-do the pairing steps, as needed. You can unpair the devices and re-pair them.

D. Performing a factory reset can clear up some issues. Refer to page 27 for instructions. If the device remains non-operational, it may be defective. **Please contact us for assistance with replacing your YoLink product.**

E. Other issues, please contact us via the info on the last page of this guide.

T Warnings

- Please install, operate and maintain the Outdoor Alarm Controller 2 only as outlined in this manual. Improper installation or use may damage the unit and/or void the warranty.
- Do not install or use the device outside of the temperature and humidity range listed in the environmental specifications.
- If used outdoors, for the maximum life of the device, provide overhead cover or a protective enclosure. This can protect it from the damaging effects of intense direct sunlight and/or rain over a period of years.
- Do not immerse or allow the devices to be immersed or submerged in water.
- Avoid placing the devices in extremely dirty or dusty environments.
- If the device does get dirty, please clean it by wiping it down with a clean dry cloth. Do not use strong chemicals or detergents, which may damage or discolor the exterior and/or damage the electronics, voiding the warranty.
- Do not install the device where it may be subjected to vandalism, abuse, physical impacts or strong vibrations. Physical damage is not covered by the warranty.

T Warnings, Continued

- Power the controller only with new C alkaline or lithium-ion batteries. Do not use rechargeable batteries, do not use other type batteries (e.g. zinc blend). Do not mix old and new batteries.
- If storing the controller for extended periods, remove the batteries.
- Please contact Customer Support before attempting to repair, disassemble or modify the device, any of which can permanently damage the device and void the warranty.



2 Year Limited Electrical Warranty

YoSmart Inc. warrants to the original user (“customer”) of this product that it will be free from defects in materials and workmanship, under normal use, for 2 years from the date of purchase. This warranty does not apply to devices that have been improperly installed, modified, put to a use other than designed, or subjected to acts of God (such as floods, lightning, earthquakes, etc.). This warranty does not cover neglected or abused products. This warranty is limited to the repair or replacement of the device, only, at YoSmart's sole discretion. YoSmart will NOT be liable for the cost of installing, removing, nor reinstalling this product, nor direct, indirect, or consequential damages to persons or property resulting from the use of this product. This warranty only covers the cost of replacement parts or replacement units, it does not cover shipping & handling fees. The customer must provide proof of purchase, in the form of the original purchase invoice or order number. The purchase must have been made from an authorized seller.

To implement this warranty please contact us by one of the methods listed on the Contact Us page of this user guide.

V FCC Statement

This equipment has been tested and found to comply with the limits for a Class B digital device, pursuant to part 15 of the FCC Rules. These limits are designed to provide reasonable protection against harmful interference in a residential installation. This equipment generates, uses and can radiate radio frequency energy and, if not installed and used in accordance with the instructions, may cause harmful interference to radio communications. However, there is no guarantee that interference will not occur in a particular installation. If this equipment does cause harmful interference to radio or television reception, which can be determined by turning the equipment off and on, the user is encouraged to try to correct the interference by one or more of the following measures: Reorient or relocate the receiving antenna, connect the equipment into an outlet on a circuit different from that to which the receiver is connected, increase the separation between the equipment and receiver, consult the dealer or an experienced radio/TV technician for help.

This device complies with part 15 of the FCC Rules. Operation is subject to the following two conditions:

- 1) This device may not cause harmful interference
- 2) This device must accept any interference received, including interference that may cause undesired operation. Any changes or modifications not expressly approved by the party responsible for compliance could void the user's authority to operate the equipment.

To maintain compliance with FCC's RF Exposure guidelines, This equipment should be installed and operated with minimum 20cm distance between the radiator and your body: Use only the supplied antenna.



FCC Statement, Continued

PRODUCT NAME:
OUTDOOR ALARM CONTROLLER 2

PARTY:
YOSMART, INC.

TELEPHONE:
831-292-4831

MODEL NUMBER:
YS7107-UC

ADDRESS:
15375 BARRANCA PKWY SUITE J-107, IRVINE,
CA 92618 USA

EMAIL:
SERVICE@YOSMART.COM



Contact Us

We are here for you, if you ever need any assistance installing, setting up or using a YoLink app or product!

Need help? For fastest service, please email us 24/7 at service@yosmart.com

Or call us at **831-292-4831** (US phone support hours: **Monday - Friday, 9AM to 5PM Pacific**)

You can also find additional support and ways to contact us at:

www.yosmart.com/support-and-service

Or scan the QR code:



Support Home Page

Finally, if you have any feedback or suggestions for us, please email us at feedback@yosmart.com

Thank you for trusting YoLink!

Eric Vanzo
Customer Experience Manager

YOLINK

15375 Barranca Parkway Ste. J-107 | Irvine, California 92618
© 2023 YOSMART, INC IRVINE, CALIFORNIA