

一、尺寸 DIMENSION:(mm)

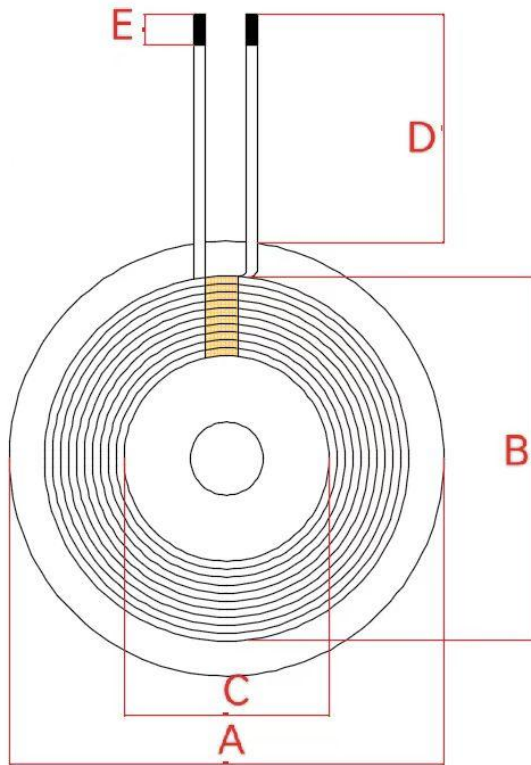

A 45±0.5

B 40.2±0.5

C 20.5±0.5

D 40±2

F 3±2

E

G

H

I

K

二、原理图 SCHEMATIC DIAGRAM:

三、绕线参数 Winding Specification:

序号 NO.	端子 TERMINAL		线径 WIRE	圈数 Turns	绕线方向 Winding Direction
1	S	F	Silk aluminum wire 0.15*24P	10Ts	CCW

四、电气特性 ELECTRICAL CHARACTERISTICS:

温度 TEMPERATURE:25±10°C, 湿度 RELATIVE HUMIDITY:65±20%

序号 NO.	项目 ITEM	端子 TERMINAL	标准 SPECIFICATION	测试条件 TEST FREQUENCY	测试仪器 TEST EQUIPMENTS
1	IND.	S-F	3.7uH ±10%Separate coil	100KHz/1.0V	LCZ METER 1062B
2	IND.	S-F	6.4H ±10%Add magnetic sheet	100KHz/1.0V	LCZ METER 1062B
3	DCR	S-F	≤50m Ω		LCZ METER 502B