

Product Description

The Ubio Labs AWC1062 is a compact, wireless charging module for AirPods and Apple Watch. It derives its power from a compatible USB-C receptacle capable of supplying power.



CMP item#: AWC1062	Description: Module, 10W Qi and Apple Watch Charger, USB-C In	
<p>ubiolabs</p> <p>This document is proprietary & confidential. Do not copy or distribute without consent.</p>	Revision: 100	Date: 08/21/2019

CMP#: AWC1062SG

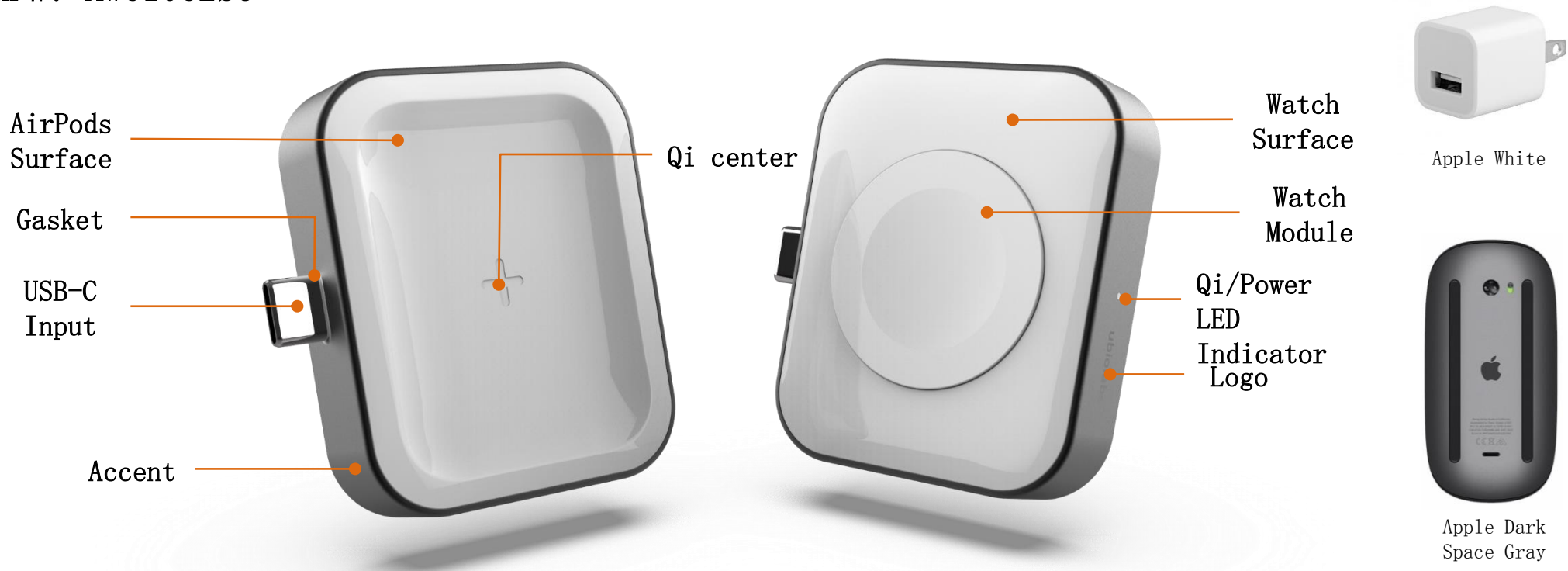

Part	Color / Material / Finish	Notes
Gasket	Apple White / ABS / YS20019	
AirPods Surface	Apple White / ABS / Gloss	
Qi Center	Apple White / ABS / Gloss	Deboss 0.1mm
Watch Surface	Apple White / ABS / Gloss	
Accent	Apple Dark Space Gray Light Blast / ABS / Paint	
Logo	Clear/ Pad Print / Gloss	
Industrial Designer:	Ken Jasinski	
STP File Name:	AWC1062 Qi and Watch USB-C in_REV100.STEP	

CMP#: AWC1062SG – AL

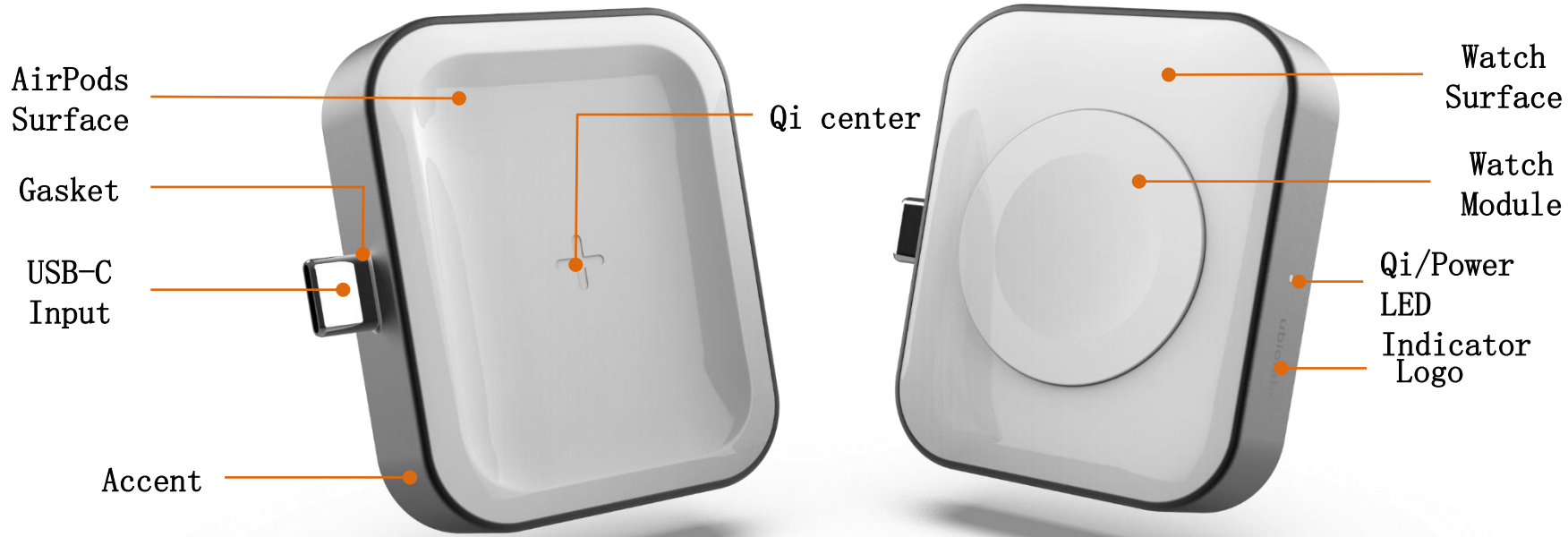

Apple White



Apple Dark Space Gray

Part	Color / Material / Finish	Notes
Gasket	Apple White / ABS / YS20019	
AirPods Surface	Apple White / ABS / Gloss	
Qi Center	Apple White / ABS / Gloss	Deboss 0.1mm
Watch Surface	Apple White / ABS / Gloss	
Accent	Apple Dark Space Gray / Aluminum / Light Blast	
Logo	Clear/ Pad Print / Gloss	
Industrial Designer:	Ken Jasinski	
STP File Name:	AWC1062 Qi and Watch USB-C in_REV100.STEP	

CMP#: AWC1062NA

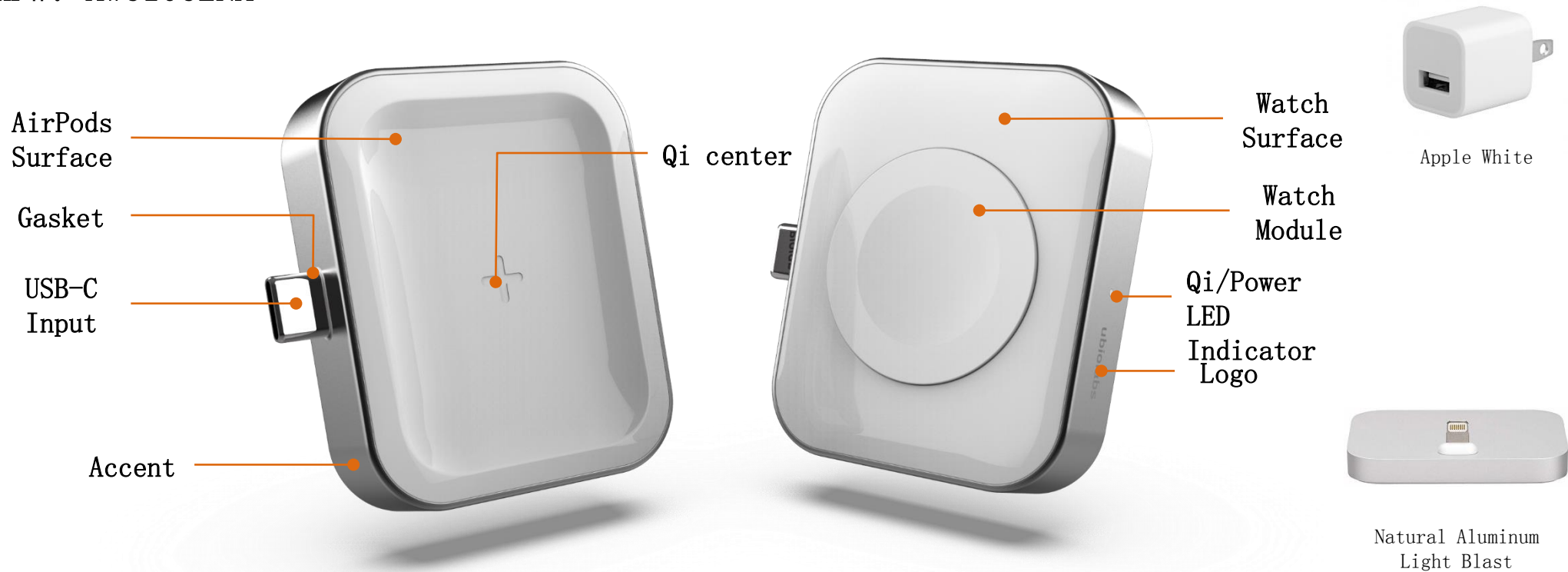

Part	Color / Material / Finish	Notes
Gasket	Apple White / ABS / YS20019	
AirPods Surface	Apple White / ABS / Gloss	
Qi Center	Apple White / ABS / Gloss	Deboss 0.1mm
Watch Surface	Apple White / ABS / Gloss	
Accent	Natural Aluminum Light Blast / ABS / Paint	
Logo	Clear/ Pad Print / Gloss	
Industrial Designer:	Ken Jasinski	
STP File Name:	AWC1062 Qi and Watch USB-C in_REV100.STEP	

CMP#: AWC1062NA – AL

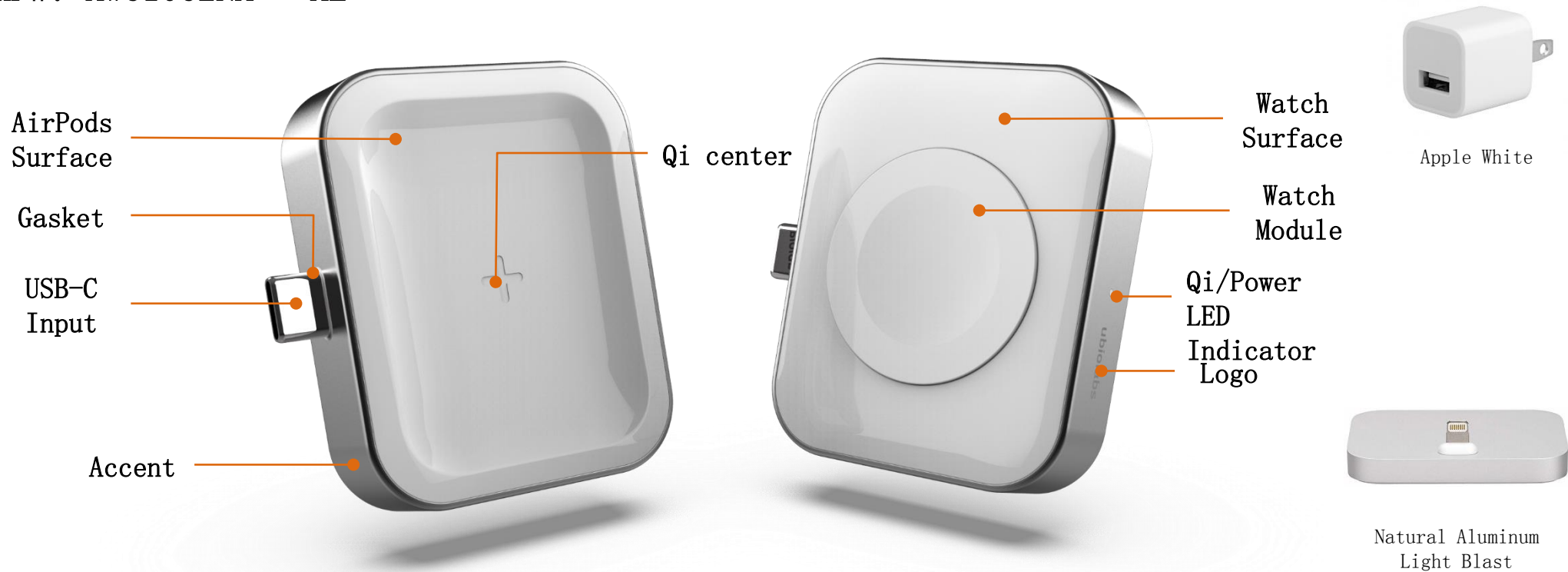

Part	Color / Material / Finish	Notes
Gasket	Apple White / ABS / YS20019	
AirPods Surface	Apple White / ABS / Gloss	
Qi Center	Apple White / ABS / Gloss	Deboss 0.1mm
Watch Surface	Apple White / ABS / Gloss	
Accent	Natural Aluminum / Aluminum / Light Blast	
Logo	Clear/ Pad Print / Gloss	
Industrial Designer:	Ken Jasinski	
STP File Name:	AWC1062 Qi and Watch USB-C in_REV100.STEP	

CMP#: AWC1062 Silkscreen

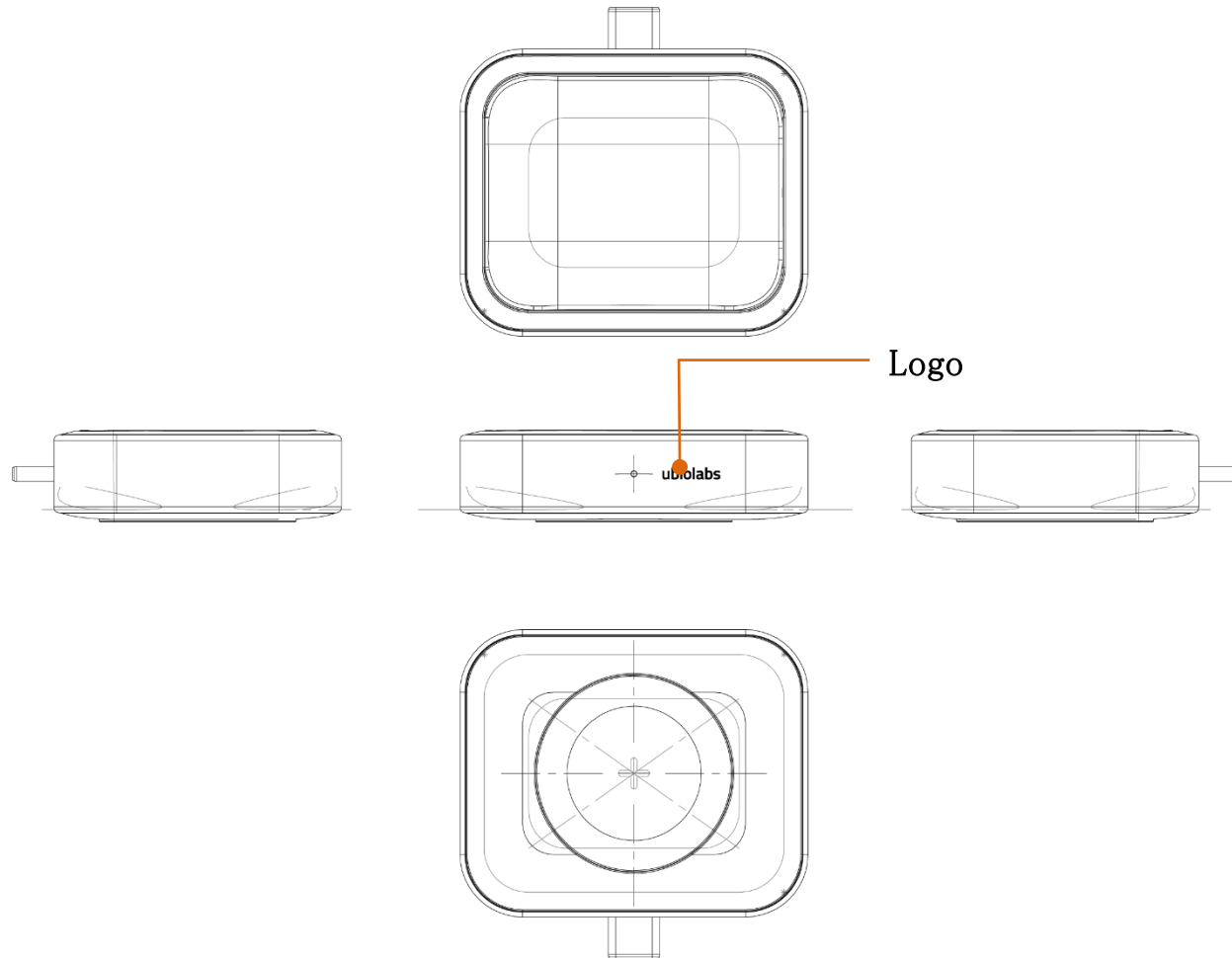

Part	Color / Material / Finish	Notes
Logo	Clear/ Pad Print / Gloss	
Industrial Designer:	Ken Jasinski	
.PDF File Name:	AWC1062 Pad Print_Logo_REV100	Regulatory marking provided later - Please include in Quote

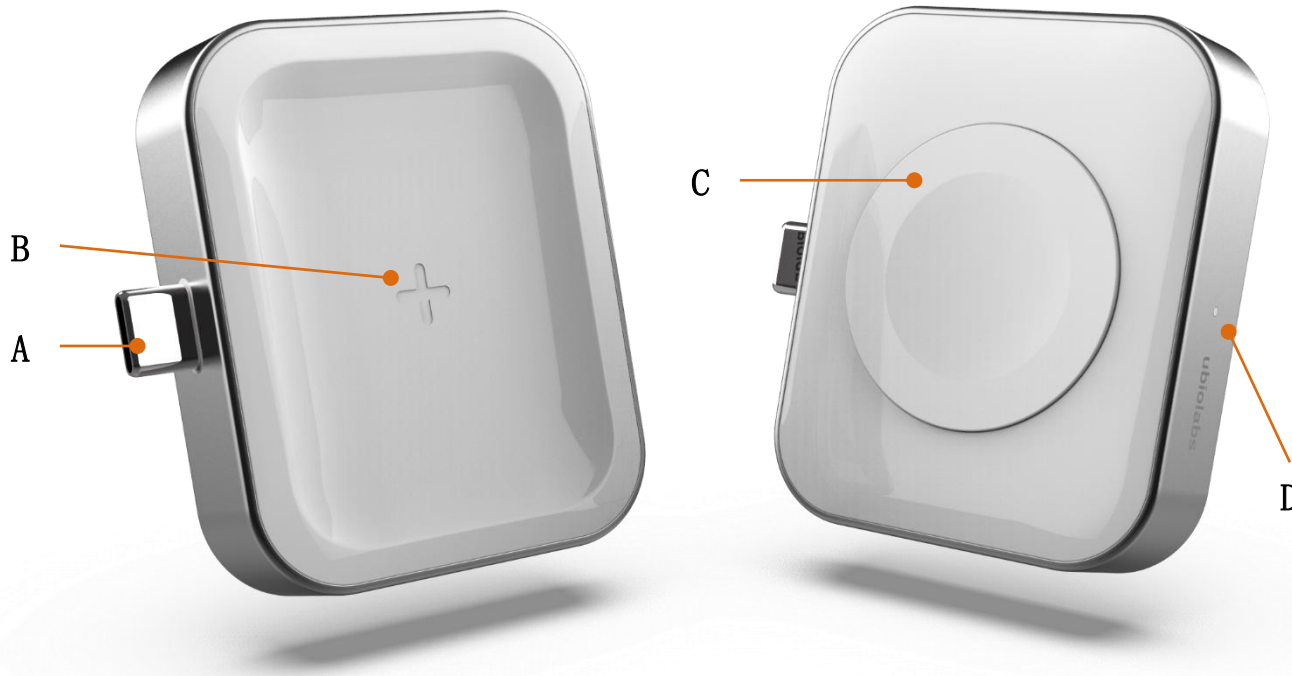

Qi/Power LED Indicator Functionality		
Condition	LED Status	Notes
Device Charging	●	Illuminates white
No device, not charging	○	Not illuminated
Fault Foreign Object Detection	●	Illuminates amber for fault due to foreign object detection
Input Power	●	Illuminates white for 1 second at power up and then turns off if no device detected
● ON ○ OFF		

- A. **USB-C Input:** The USB-C Input is used to provide power to the wireless charging module. Plugging the module into a compatible USB-C receptacle will automatically power up the module and remain on as long as the module is plugged in.
- B. **Qi Coil:** The Qi coil placed behind the top cover will allow charging of wireless AirPods case immediately upon placement on the coil location. This will initiate the Qi/Power Indicator functionality.
- C. **Watch Charger:** The Apple Magnetic charging module allows an Apple watch to magnetically attach and immediately begin charging. This will initiate the Qi/Power LED Indicator functionality.
- D. **Qi/Power LED Indicator:** The Qi/Power Indicator is a dual color White/Amber LED. It shall illuminate as described in the table above.
- E. **Charge Priority:** This product is designed to only charge one device at a time. If it does get subjected to two devices requesting a charge, the first device to initiate a charge handshake will take priority. The second device charging will be disabled during the first device charging duration.

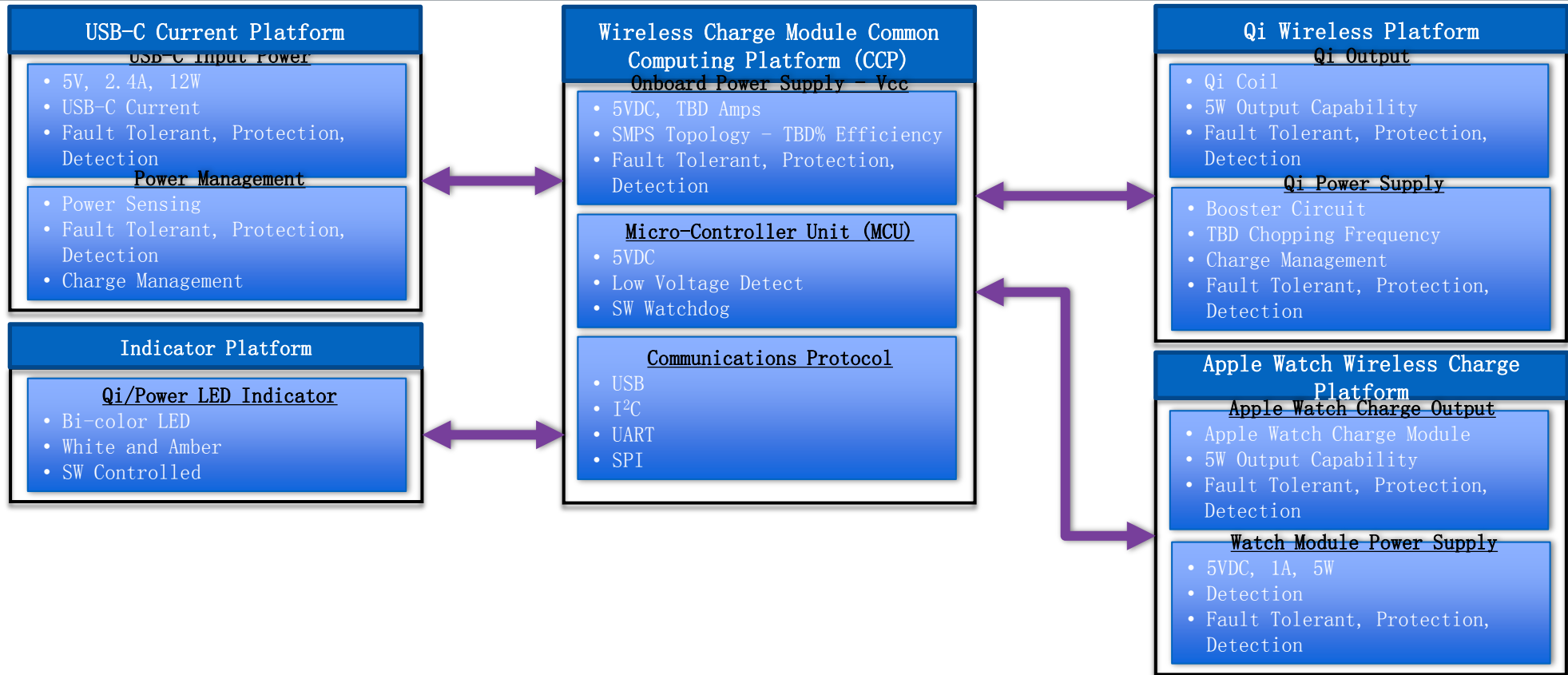

- A. **Platform Based Design:** The AirPlugs product family shall be designed such that it is modular in nature for Hardware, Software, Mechanical functionality, design reusability and platformization. All adjustable variables such as time delays, duty cycles, frequencies etc. shall be software controlled to reduce impact to hardware in anticipation of standards and specification changes in the future.
- B. **USB-C Current Platform:** This platform accepts USB-C input from a compatible USB-C device. All end-user facing I/O' s, onboard I/O' s, interfaces and functionality pertaining to this platform shall be designed to comply with the applicable USB and MFi specifications.
- C. **Indicator Platform:** This platform provides the Indicator User Interface (UI) capability. All end-user facing I/O' s, onboard I/O' s, interfaces and functionality pertaining to this platform shall be designed to comply with the indicator functionality described here within this document.
- D. **Wireless Charge Module Common Computing Platform (CCP):** This platform provides the control logic and communication capabilities. All software functions, interfaces and libraries should be modular to align with hardware functionality and vice-versa. For example, USB-C Current I/O Platform Hardware and Software are modular and go together. Standard software development tools and common hardware chipsets shall be used to ensure ease of development and debugging.
- E. **Qi Wireless Platform:** This platform provides Qi Wireless Charging capability. All end-user facing I/O' s, onboard I/O' s, interfaces and functionality pertaining to this platform shall be designed to comply with the applicable Qi and MFi specifications.
- F. **Apple Watch Wireless Charge Platform:** This platform provides Apple Watch Wireless Charging capability. All end-user facing I/O' s, onboard I/O' s, interfaces and functionality pertaining to this platform shall be designed to comply with the applicable MFi specifications.

Performance Specifications	
Input 1	USB-C Input Plug - 5V, 2.4A, 12W
Output 1	Qi Inductive Output - 5W BPP
Output 2	Apple Magnetic Charge Output - 5V, 1A, 5W
Dimensions (H x W x D)	14.65mm x 55.7mm x 46mm
Weight	55g

NOTES:

1. All inputs and outputs shall be designed to meet the Apple MFi standard, where applicable, even if they don't see the full load of the device attached to it.
2. All USB-C Inputs/Outputs shall be design to comply with USB-IF compliance, where applicable.

FCC COMPLIANCE STATEMENT:

This device complies with part 15 of the FCC Rules. Operation is subject to the following two conditions: (1) This device may not cause harmful interference, and (2) this device must accept any interference received, including interference that may cause undesired operation. Changes or modifications not expressly approved by the party responsible for compliance could void the user's authority to operate the equipment.

IC WARNING

This device contains licence-exempt transmitter(s)/receiver(s) that comply with Innovation, Science and Economic Development Canada's licence-exempt RSS(s). Operation is subject to the following two conditions:

- (1) This device may not cause interference.
- (2) This device must accept any interference, including interference that may cause undesired operation of the device

ADVERTENCIA IC

Cet appareil contient des émetteurs / récepteurs exemptés de licence conformes aux RSS (RSS) d'Innovation, Sciences et Développement économique Canada. Le fonctionnement est soumis aux deux conditions suivantes :

- (1) Cet appareil ne doit pas causer d'interférences.
- (2) Cet appareil doit accepter toutes les interférences, y compris celles susceptibles de provoquer un fonctionnement indésirable de l'appareil.