



■ Report No.: DDT-R21053108-1E01

■ Issued Date: Jun. 10, 2021

FCC CERTIFICATION TEST REPORT

FOR

Applicant	:	UNIONMAN TECHNOLOGY CO., LTD
Address	:	No.5 Huitai Road, Huinan High-Tech Industrial Park, Huizhou City, Guangdong, China.
Equipment under Test	:	WiFi6 CPE
Model No.	:	UNR032H, UNR033H
Trade Mark	:	/
FCC ID	:	2ATGV-UNR032H
Manufacturer	:	UNIONMAN TECHNOLOGY CO., LTD
Address	:	No.5 Huitai Road, Huinan High-Tech Industrial Park, Huizhou City, Guangdong, China.

Issued By: Dongguan Dongdian Testing Service Co., Ltd.

Add.: No. 17, Zongbu Road 2, Songshan Lake Sci&Tech, Industry Park,
Dongguan City, Guangdong Province, China, 523808

Tel.: +86-0769-38826678, **E-mail:** ddt@dgddt.com, <http://www.dgddt.com>

REPORT

Table of Contents

	Test report declares.....	4
1.	Summary of Test Results.....	6
2.	General Test Information	7
2.1.	Description of EUT	7
2.2.	Accessories of EUT.....	7
2.3.	Assistant equipment used for test.....	7
2.4.	Block diagram of EUT configuration for test.....	7
2.5.	Deviations of test standard.....	8
2.6.	Test environment conditions	8
2.7.	Test laboratory.....	8
2.8.	Measurement uncertainty.....	9
3.	Equipment Used During Test.....	10
4.	26 dB Bandwidth and 6 dB Bandwidth.....	12
4.1.	Block diagram of test setup.....	12
4.2.	Limits	12
4.3.	Test procedure	12
4.4.	Test result.....	13
4.5.	Original test data	13
5.	Maximum Output Power	14
5.1.	Block diagram of test setup.....	14
5.2.	Limits	14
5.3.	Test procedure	14
5.4.	Test result.....	14
6.	Power Spectral Density.....	15
6.1.	Block diagram of test setup.....	15
6.2.	Limits	15
6.3.	Test procedure	15
6.4.	Test result.....	16
6.5.	Original test data	16
7.	Frequency Stability Measurement	17
7.1.	Limit of frequency stability.....	17
7.2.	Measuring instruments.....	17
7.3.	Test procedures	17
7.4.	Test setup.....	17
7.5.	Test result.....	17
8.	Spurious Emissions.....	19

8.1.	Block diagram of test setup.....	19
8.2.	Limit.....	20
8.3.	Test procedure	21
8.4.	Test result.....	23
9.	Band Edge Compliance	27
9.1.	Block diagram of test setup.....	27
9.2.	Limit.....	27
9.3.	Test procedure	28
9.4.	Test result.....	28
10.	Power Line Conducted Emission.....	33
10.1.	Block diagram of test setup.....	33
10.2.	Power line conducted emission limits (Class B).....	33
10.3.	Test procedure	33
10.4.	Test result.....	34
11.	Antenna Requirements	37
11.1.	Limit.....	37
11.2.	Result	37
12.	Test Setup Photograph	38

Test Report Declare

Applicant	:	UNIONMAN TECHNOLOGY CO., LTD
Address	:	No.5 Huitai Road, Huinan High-Tech Industrial Park, Huizhou City, Guangdong, China.
Equipment under Test	:	WiFi6 CPE
Model No	:	UNR032H, UNR033H
Trade Mark	:	/
Manufacturer	:	UNIONMAN TECHNOLOGY CO., LTD
Address	:	No.5 Huitai Road, Huinan High-Tech Industrial Park, Huizhou City, Guangdong, China.

Test Standard Used: FCC Rules and Regulations Part 15 Subpart E.

Test procedure used: ANSI C63.10:2013, 789033 D02 General U-NII Test Procedures New Rules v02r01

We Declare:

The equipment described above is tested by Dongguan Dongdian Testing Service Co., Ltd and in the configuration tested the equipment complied with the standards specified above. The test results are contained in this test report and Dongguan Dongdian Testing Service Co., Ltd is assumed of full responsibility for the accuracy and completeness of these tests.

After test and evaluation, our opinion is that the equipment provided for test compliance with the requirement of the above FCC standards.

Report No:	DDT-R21053108-1E01		
Date of Receipt:	Jun. 01, 2021	Date of Test:	Jun. 01, 2021 ~ Jun. 09, 2021

Prepared By:

Sam Li

Sam Li/Engineer

Approved By:



Damon Hu/EMC Manager

Note: This report applies to above tested sample only. This report shall not be reproduced in parts without written approval of Dongguan Dongdian Testing Service Co., Ltd.

Revision History

Rev.	Revisions	Issue Date	Revised By
---	Initial issue	Jun. 10, 2021	

1. Summary of Test Results

The EUT have been tested according to the applicable standards as referenced below.

Description of Test Item	Standard	Results
6/26 dB Bandwidth	FCC 15.407 (e)	Pass
Maximum Conducted Output Power	FCC 15.407 (a)	Pass
Power Spectral Density	FCC 15.407 (a)	Pass
Frequency Stability Measurement	FCC 15.407 (g)	Pass [®]
Spurious Emissions	FCC 15.407 (b) FCC 15.209	Pass
Band Edge Compliance	FCC 15.407 (b) FCC 15.209 FCC 15.205 [®]	Pass
Power Line Conducted Emission	FCC 15.207	Pass
Antenna Requirement	FCC 15.203	Pass
Dynamic Frequency Selection	FCC 15.407 (h)	N/A

Note: N/A is an abbreviation for Not Applicable.

2. General Test Information

2.1. Description of EUT

EUT* Name	: WiFi6 CPE
Model Number	: UNR032H, UNR033H
Difference of models	: All models are identical except the model name, therefore UNR032H was tested and recorded in this report.
EUT function description	: Please reference user manual of this device
Power Supply	: AC 120V/60Hz
Radio Technology	: IEEE 802.11ax
Operation frequency	: IEEE 802.11ax HT80: 5210 MHz
Modulation	: IEEE 802.11ax: OFDM (1024QAM, 256QAM, 64QAM, 16QAM, QPSK, BPSK)
Transmitter rate	: IEEE 802.11ax HT80: up to 600 Mbps
Antenna Type	: Antenna 1: External antenna, maximum PK gain: 2 dBi : Antenna 2: External antenna, maximum PK gain: 3 dBi The EUT support 2T2R MIMO mode.
Serial Number	: N/A

Note: EUT is the abbreviation of equipment under test.

Antenna information			
Mode	Ant1 gain	Ant2 gain	2T2R MIMO
IEEE 802.11ax VHT80	2	3	6.01

Note: The directional gain shall be calculated as the sum of 10 log (number of array elements or staves) plus the directional gain of the element or stave having the highest gain.

2.2. Accessories of EUT

Description of Accessories	Manufacturer	Model number	Description	Remark
N/A	N/A	N/A	N/A	N/A

2.3. Assistant equipment used for test

Assistant equipment	Manufacturer	Model number	EMC Compliance	SN
Notebook	Lenovo Beijing Co. Ltd.	ThinkPad	FCC/CE	TP00015A

2.4. Block diagram of EUT configuration for test



The test software was used to control EUT work in Continuous Tx mode, and select test channel, wireless mode as below table.

Tested mode, channel, and data rate information				
Mode	Setting Tx Power	data rate (Mbps) (see Note)	Channel	Frequency (MHz)
IEEE 802.11ax HT80	/	MCS0	CH42	5210
Note: According exploratory test, EUT will have maximum output power in those data rate, so those data rate were used for all test.				

2.5. Deviations of test standard

No deviation.

2.6. Test environment conditions

During the measurement the environmental conditions were within the listed ranges:

Temperature range:	21-25 °C
Humidity range:	40-75%
Pressure range:	86-106 kPa

2.7. Test laboratory

Dongguan Dongdian Testing Service Co., Ltd.

Add.: No. 17, Zongbu Road 2, Songshan Lake Sci&Tech, Industry Park, Dongguan City, Guangdong Province, China, 523808.

Tel.: +86-0769-38826678, <http://www.dgddt.com>, Email: ddt@dgddt.com.

CNAS Accreditation No. L6451; A2LA Accreditation Number: 3870.01

FCC Designation Number: CN1182, Test Firm Registration Number: 540522

Innovation, Science and Economic Development Canada Site Registration Number: 10288A

Conformity Assessment Body identifier: CN0048

VCCI facility registration number: C-20087, T-20088, R-20123, G-20118

2.8. Measurement uncertainty

Test Item	Uncertainty
Bandwidth	1.1%
Peak Output Power (Conducted) (Spectrum Analyzer)	0.86 dB (10 MHz ≤ f < 3.6 GHz);
	1.38 dB (3.6 GHz ≤ f < 8 GHz)
Peak Output Power (Conducted) (Power Sensor)	0.74 dB
Power Spectral Density	0.74 dB (10 MHz ≤ f < 3.6 GHz);
	1.38 dB (3.6 GHz ≤ f < 8 GHz)
Frequencies Stability	6.7 x 10 ⁻⁸ (Antenna couple method)
	5.5 x 10 ⁻⁸ (Conducted method)
Conducted Spurious Emissions	0.86 dB (10 MHz ≤ f < 3.6 GHz);
	1.40 dB (3.6 GHz ≤ f < 8 GHz)
	1.66 dB (8 GHz ≤ f < 22 GHz)
Uncertainty for Radio Frequency (RBW < 20 kHz)	3×10 ⁻⁸
Temperature	0.4 °C
Humidity	2 %
Uncertainty for Radiation Emission Test (30 MHz - 1 GHz)	4.70 dB (Antenna Polarize: V)
	4.84 dB (Antenna Polarize: H)
Uncertainty for Radiation Emission Test (1 GHz - 40 GHz)	4.10 dB (1 - 6 GHz)
	4.40 dB (6 GHz - 18 GHz)
	3.54 dB (18 GHz - 26 GHz)
	4.30 dB (26 GHz - 40 GHz)
Uncertainty for Power Line Conduction Emission Test	3.32 dB (150 kHz - 30 MHz)
Note: This uncertainty represents an expanded uncertainty expressed at approximately the 95% confidence level using a coverage factor of k=2.	

3. Equipment Used During Test

Equipment	Manufacturer	Model No.	Serial No.	Last Cal.	Cal. Interval
<input type="checkbox"/> RF Connected Test (Tonscend RF Measurement System 1#)					
Spectrum analyzer	R&S	FSU26	101272	Jul. 01, 2020	1 Year
Spectrum analyzer	Agilent	N9020D	MY49100362	Sep. 28, 2020	1 Year
Wideband Radio Communication tester	R&S	CMW500	117491	Jul. 01, 2020	1 Year
Vector Signal Generator	Agilent	E8267D	US49060192	Sep. 24, 2020	1 Year
Vector Signal Generator	Agilent	N5182A	MY48180737	Jul. 01, 2020	1 Year
Power Sensor	Agilent	U2021XA	MY55150010	Jul. 01, 2020	1 Year
Power Sensor	Agilent	U2021XA	MY55150011	Jul. 01, 2020	1 Year
RF Cable	Micable	C10-01-01-1	100309	Sep. 28, 2020	1 Year
Temp&Humi Programmable	ZHIXIANG	ZXGDJS-15 0L	ZX170110-A	Jul. 01, 2020	1 Year
Test Software	JS Tonscend	JS1120-3	Ver.2.7	N/A	N/A
<input checked="" type="checkbox"/> RF Connected Test (Tonscend RF Measurement System 2#)					
Spectrum analyzer	R&S	FSU26	200071	Sep. 25, 2020	1 Year
Spectrum analyzer	Agilent	N9020D	MY49100362	Sep. 28, 2020	1 Year
Wideband Radio Communication tester	R&S	CMW500	117491	Jul. 01, 2020	1 Year
Vector Signal Generator	Agilent	N5182A	MY19060405	Jul. 01, 2020	1 Year
Vector Signal Generator	Agilent	N5182A	MY48180912	Jul. 01, 2020	1 Year
RF Control Unit	Tonsend	JS0806-2	DDT-ZC01449	Jul. 01, 2020	1 Year
RF Cable	Micable	C10-01-01-1	100309	Sep. 28, 2020	1 Year
Temp&Humi Programmable	ZHIXIANG	ZXGDJS-15 0L	ZX170110-A	Jul. 01, 2020	1 Year
Test Software	JS Tonscend	JS1120-3	Ver.2.7	N/A	N/A
<input type="checkbox"/> Radiation 1#chamber					
EMI Test Receiver	R&S	ESU8	100316	Sep. 24, 2020	1 Year
Spectrum analyzer	Agilent	E4447A	MY50180031	Jul. 01, 2020	1 Year
Trilog Broadband Antenna	Schwarzbeck	VULB9163	9163-462	Nov. 13, 2020	1 Year
Active Loop antenna	Schwarzbeck	FMZB-1519	1519-038	Nov. 18, 2020	1 Year
Double Ridged Horn Antenna	R&S	HF907	100276	Nov. 13, 2020	1 Year
Broad Band Horn Antenna	Schwarzbeck	BBHA 9170	790	May 08, 2021	1 Year
Pre-amplifier	A.H.	PAM-0118	360	Sep. 28, 2020	1 Year
RF Cable	HUBSER	CP-X2+ CP-X1	W11.03+ W12.02	Sep. 24, 2020	1 Year
RF Cable	N/A	5m+6m+1m	06270619	Sep. 30, 2020	1 Year
MI Cable	HUBSER	C10-01-01-1 M	1091629	Sep. 30, 2020	1 Year
Test software	Audix	E3	V 6.11111b	N/A	N/A

<input checked="" type="checkbox"/> Radiation 2#chamber					
EMI Test Receiver	R&S	ESCI	101364	Sep. 28, 2020	1 Year
Spectrum analyzer	Agilent	E4447A	MY50180031	Jul. 01, 2020	1 Year
Trilog Broadband Antenna	Schwarzbeck	VULB 9163	9163-994	Nov. 13, 2020	1 Year
Active Loop antenna	Schwarzbeck	FMZB-1519	1519-038	Nov. 18, 2020	1 Year
Double Ridged Horn Antenna	Schwarzbeck	BBHA9120	02108	Jul. 11, 2020	1 Year
Broad Band Horn Antenna	Schwarzbeck	BBHA 9170	790	May 08, 2021	1 Year
Pre-amplifier	TERA-MW	TRLA-0040 G35	1013 03	Sep. 28, 2020	1 Year
RF Cable	N/A	14+1.5m	06270619	Sep. 28, 2020	1 Year
Test software	Audix	E3	V 6.11111b	N/A	N/A
<input type="checkbox"/> Power Line Conducted Emissions Test 1#					
EMI Test Receiver	R&S	ESU8	100316	Sep. 24, 2020	1 Year
LISN 1	R&S	ENV216	101109	Sep. 28, 2020	1 Year
LISN 2	R&S	ESH2-Z5	100309	Sep. 28, 2020	1 Year
Pulse Limiter	R&S	ESH3-Z2	101242	Sep. 24, 2020	1 Year
CE Cable 1	HUBSER	N/A	W10.01	Sep. 24, 2020	1 Year
Test software	Audix	E3	V 6.11111b	N/A	N/A
<input checked="" type="checkbox"/> Power Line Conducted Emissions Test 2#					
Test Receiver	R&S	ESPI	101761	Sep. 24, 2020	1 Year
LISN 1	R&S	ENV216	101170	Sep. 28, 2020	1 Year
LISN 2	R&S	ESH2-Z5	100309	Sep. 28, 2020	1 Year
Pulse Limiter	R&S	KH43101	43101180156 8-12#	Jul. 01, 2020	1 Year
CE Cable 2	HUBSER	N/A	W11.02	Sep. 24, 2020	1 Year
Test software	Audix	E3	V 6.11111b	N/A	N/A

4. 26 dB Bandwidth and 6 dB Bandwidth

4.1. Block diagram of test setup

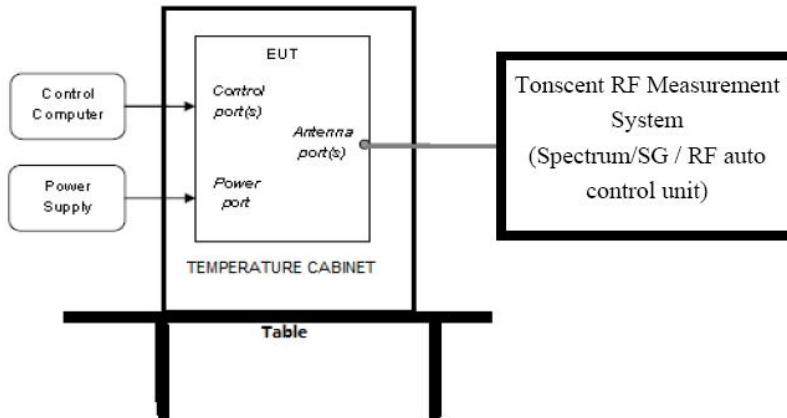

4.2. Limits

FCC Part15, Subpart E		
Test Item	Limit	Frequency Range (MHz)
Bandwidth	26 dB Bandwidth	5150 - 5250
	26 dB Bandwidth	5250 - 5350
	26 dB Bandwidth	5470 - 5725
	Minimum 500 kHz 6 dB Bandwidth	5725 - 5850

4.3. Test procedure

(1) Connect EUT's antenna output to spectrum analyzer by RF cable.

Center Frequency	The centre frequency of the channel under test
Detector	Peak
RBW	For 6 dB Bandwidth: RBW=100 kHz For 26 dB Bandwidth: approximately 1% of the emission bandwidth.
VBW	For 6 dB Bandwidth: VBW=300 kHz For 26 dB Bandwidth: >3 RBW
Trace	Max hold
Sweep	Auto couple

(2) Allow the trace to stabilize, measure the maximum width of the emission that is constrained by the frequencies associated with the two outermost amplitude points (upper and lower frequencies) that are attenuated by 26 dB and 6 dB relative to the maximum level measured in the fundamental emission.

4.4. Test result

26 dB EBW:

Test Mode	Antenna	Channel	26 dB EBW [MHz]	FL [MHz]	FH [MHz]	Limit [MHz]	Verdict
11AX80 MIMO	Ant1	5210	84.480	5167.760	5252.240	---	Pass
	Ant2	5210	83.840	5168.080	5251.920	---	Pass

4.5. Original test data

26 dB EBW:



5. Maximum Output Power

5.1. Block diagram of test setup

Same as section 4.1

5.2. Limits

FCC Part15, Subpart E		
Test Item	Limit	Frequency Range (MHz)
Conducted Output Power	For FCC client devices: 250 mW (24 dBm)	5150 - 5250
	For FCC: 250 mW (24 dBm) or $11 + 10 \log_{10} B$	5250 - 5350
	For FCC: 250 mW (24 dBm) or $11 + 10 \log_{10} B$	5470 - 5725
	1 Watt (30 dBm)	5725 - 5850
Note1: For FCC: B = 26 dB bandwidth. Note2: For 802.11ax, the EUT incorporates a MIMO function. The Antenna directional gain is 6.01 dBi. The Output Power limit is the above limits-(6.01-6)		

5.3. Test procedure

- (1) Connect each EUT's antenna output to Power Sensor by RF cable and attenuator
- (2) Add each antenna port's results to get the total output power of EUT.

5.4. Test result

Test Mode	Antenna	Channel	Result [dBm]	Limit [dBm]	Verdict
11AX80 MIMO	Ant1	5210	16.15	≤ 23.99	Pass
	Ant2	5210	17.51	≤ 23.99	Pass
	total	5210	19.89	≤ 23.99	Pass

6. Power Spectral Density

6.1. Block diagram of test setup

Same with 4.1

6.2. Limits

FCC Part15, Subpart E		
Test Item	Limit	Frequency Range (MHz)
Power Spectral Density	For FCC: Other than Mobile and portable: 17 dBm/MHz Mobile and portable client devices: 11 dBm/MHz	5150 - 5250
	11 dBm/MHz	5250 - 5350
	11 dBm/MHz	5470 - 5725
	30 dBm/500 kHz	5725 - 5850
Note: For 802.11ax, the EUT incorporates a MIMO function. The Antenna directional gain is 6.01 dBi. The Output Power limit is the above limits-(6.01-6)		

6.3. Test procedure

The transmitter output was connected to a spectrum analyzer. Power density was measured by spectrum analyzer with 1 MHz RBW and 3 MHz VBW.

Connect the UUT to the spectrum analyser and use the following settings:

5150 MHz ~ 5250 MHz, 5250 MHz ~ 5350 MHz, 5470 MHz ~ 5725 MHz

Center Frequency	The centre frequency of the channel under test
Detector	RMS
RBW	1 MHz
VBW	$\geq 3 \times \text{RBW}$
Span	Encompass the entire emissions bandwidth (EBW) of the signal
Trace	Max hold
Sweep time	Auto

5725 MHz - 5850 MHz

Center Frequency	The centre frequency of the channel under test
Detector	RMS
RBW	500 kHz
VBW	$\geq 3 \times \text{RBW}$
Span	Encompass the entire emissions bandwidth (EBW) of the signal
Trace	Max hold
Sweep time	Auto

6.4. Test result

(5150 - 5250)

Test Mode	Antenna	Channel	Result [dBm/MHz]	Limit [dBm/MHz]	Verdict
11AX80 MIMO	Ant1	5210	1.33	<=10.99	Pass
	Ant2	5210	1.27	<=10.99	Pass
	total	5210	4.31	<=10.99	Pass

6.5. Original test data



7. Frequency Stability Measurement

7.1. Limit of frequency stability

Manufacturers of U-NII devices are responsible for ensuring frequency stability such that an emission is maintained within the band of operation under all conditions of normal operation as specified in the user's manual.

7.2. Measuring instruments

The measuring equipment is listed in the section 4 of this test report.

7.3. Test procedures

(1) To ensure emission at the band edge is maintained within the authorized band, those values shall be measured by radiation emissions at upper and lower frequency points, and finally compensated by frequency deviation as procedures below.

(2) The EUT was operated at the maximum output power, and connected to the spectrum analyzer, which is set to maximum hold function and peak detector. The peak value of the power envelope was measured and noted. The upper and lower frequency points were respectively measured relatively 10 dB lower than the measured peak value.

(3) The frequency deviation was calculated by adding the upper frequency point and the lower frequency point divided by two. Those detailed values of frequency deviation are provided in table below.

7.4. Test setup

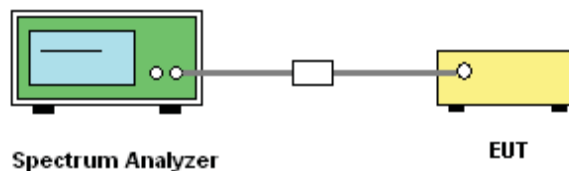

7.5. Test result

Voltage								
Test Mode	Antenna	Channel	Voltage [Vdc]	Temperature (°C)	Deviation (Hz)	Deviation (ppm)	Limit (ppm)	Verdict
11AX80 MIMO	Ant1	5210	NV	NT	-7000	-1.34357	20	Pass
			LV	NT	-7000	-1.34357	20	Pass
			HV	NT	-7000	-1.34357	20	Pass
	Ant2	5210	NV	NT	-7000	-1.34357	20	Pass
			LV	NT	-7000	-1.34357	20	Pass
			HV	NT	-7000	-1.34357	20	Pass

Temperature								
Test Mode	Antenna	Channel	Voltage [Vdc]	Temperature (°C)	Deviation (Hz)	Deviation (ppm)	Limit (ppm)	Verdict
11AX80 MIMO	Ant1	5210	NV	-30	-7000	-1.34357	20	Pass
			NV	-20	-7000	-1.34357	20	Pass
			NV	-10	-7000	-1.34357	20	Pass

Ant2	5210	NV	0	-6000	-1.151631	20	Pass
		NV	10	-6000	-1.151631	20	Pass
		NV	20	-7000	-1.34357	20	Pass
		NV	30	-7000	-1.34357	20	Pass
		NV	40	-7000	-1.34357	20	Pass
		NV	50	-7000	-1.34357	20	Pass
	5210	NV	-30	-7000	-1.34357	20	Pass
		NV	-20	-7000	-1.34357	20	Pass
		NV	-10	-7000	-1.34357	20	Pass
		NV	0	-7000	-1.34357	20	Pass
		NV	10	-7000	-1.34357	20	Pass
		NV	20	-7000	-1.34357	20	Pass
		NV	30	-7000	-1.34357	20	Pass
		NV	40	-7000	-1.34357	20	Pass
		NV	50	-7000	-1.34357	20	Pass

8. Spurious Emissions

8.1. Block diagram of test setup

In 3 m Anechoic Chamber Test Setup Diagram for 9 kHz - 30 MHz

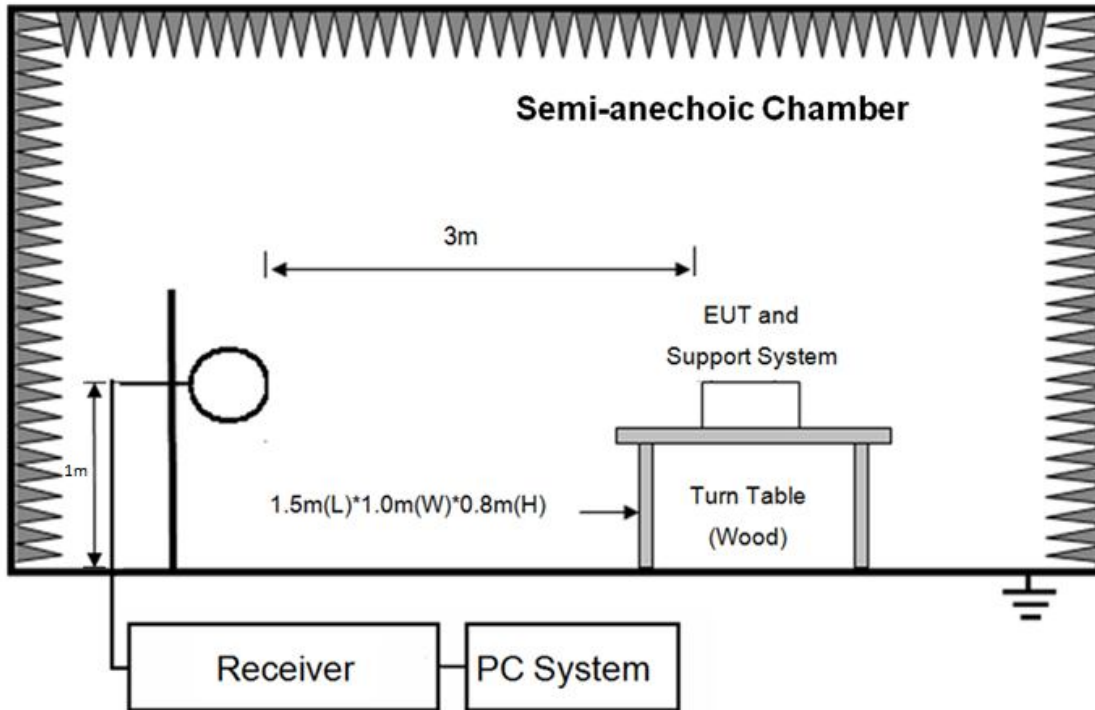

In 3 m Anechoic Chamber Test Setup Diagram for 30 MHz - 1 GHz

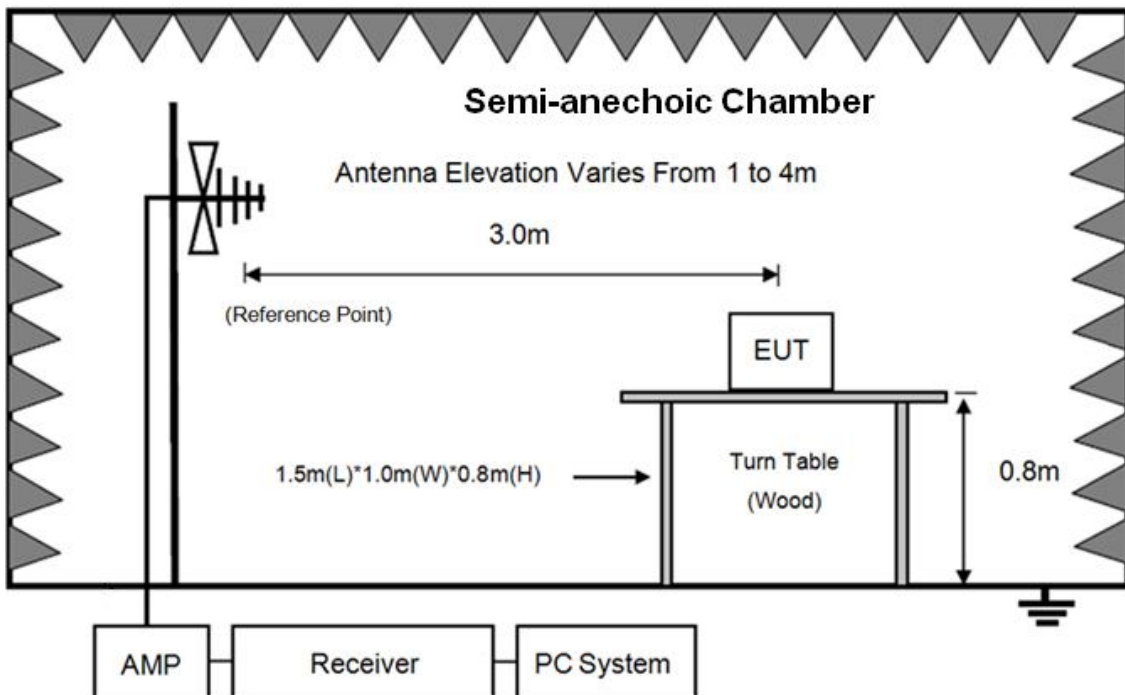

In 3 m Anechoic Chamber Test Setup Diagram for frequency above 1 GHz

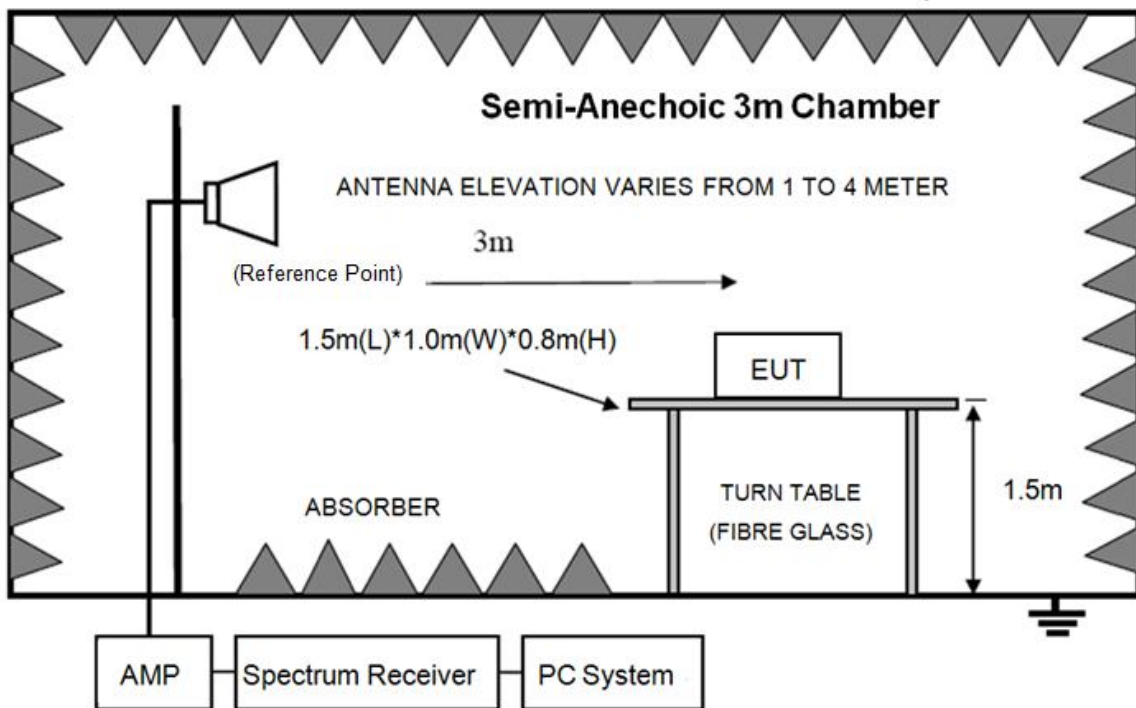

Note: For harmonic emissions test an appropriate high pass filter was inserted in the input port of AMP.

8.2. Limit

8.3.1 FCC 15.205 Restricted frequency band

MHz	MHz	MHz	GHz
0.090-0.110	16.42-16.423	399.9-410	4.5-5.15
¹ 0.495-0.505	16.69475-16.69525	608-614	5.35-5.46
2.1735-2.1905	16.80425-16.80475	960-1240	7.25-7.75
4.125-4.128	25.5-25.67	1300-1427	8.025-8.5
4.1772&4.17775	37.5-38.25	1435-1626.5	9.0-9.2
4.2072&4.20775	73-74.6	1645.5-1646.5	9.3-9.5
6.215-6.218	74.8-75.2	1660-1710	10.6-12.7
6.26775-6.26825	108-121.94	1718.8-1722.2	13.25-13.4
6.31175-6.31225	123-138	2200-2300	14.47-14.5
8.291-8.294	149.9-150.05	2310-2390	15.35-16.2
8.362-8.366	156.52475-156.52525	2483.5-2500	17.7-21.4
8.37625-8.38675	156.7-156.9	2690-2900	22.01-23.12
8.41425-8.41475	162.0125-167.17	3260-3267	23.6-24.0
12.29-12.293	167.72-173.2	3332-3339	31.2-31.8
12.51975-12.52025	240-285	3345.8-3358	36.43-36.5
12.57675-12.57725	322-335.4	3600-4400	(²)
13.36-13.41			

¹Until February 1, 1999, this restricted band shall be 0.490-0.510 MHz.

²Above 38.6

8.3.2 FCC 15.209 Limit.

FREQUENCY MHz	DISTANCE Meters	FIELD STRENGTHS LIMIT	
		$\mu\text{V}/\text{m}$	$\text{dB}(\mu\text{V})/\text{m}$
0.009 ~ 0.490	300	2400/F(kHz)	67.6-20log(F)
0.490 ~ 1.705	30	24000/F(kHz)	87.6-20log(F)
1.705 ~ 30.0	30	30	29.54
30 ~ 88	3	100	40.0
88 ~ 216	3	150	43.5
216 ~ 960	3	200	46.0
960 ~ 1000	3	500	54.0
Above 1000	3	74.0 dB(μV)/m (Peak) 54.0 dB(μV)/m (Average)	

Note: (1) The emission limits shown in the above table are based on measurements employing a CISPR QP detector except for the frequency bands 9 - 90 kHz, 110 - 490 kHz and above 1000 MHz. Radiated emissions limits in these three bands are based on measurements employing an average detector.

(2) At frequencies below 30 MHz, measurement may be performed at a distance closer than that specified, and the limit at closer measurement distance can be extrapolated by below formula:

$$\text{Limit}_{3\text{m}}(\text{dB}\mu\text{V}/\text{m}) = \text{Limit}_{30\text{m}}(\text{dB}\mu\text{V}/\text{m}) + 40\text{Log}(30\text{m}/3\text{m})$$

8.3.3 Limit for this EUT

All the emissions appearing within 15.205 restricted frequency bands shall not exceed the limits shown in 15.209, all the other emissions shall be at least 20 dB below the fundamental emissions or comply with 15.209 limits.

8.3. Test procedure

- (1) EUT height should be 0.8 m for below 1 GHz at a semi - anechoic chamber while EUT height should be 1.5 m for above 1 GHz at full chamber or semi - anechoic chamber ground with absorbers
- (2) Setup EUT and assistant system according clause 2.3 and 8.2
- (3) Test antenna was located 3 m from the EUT on an adjustable mast, and the antenna used as below table.

Test frequency range	Test antenna used	Test distance
9 kHz - 30 MHz	Active Loop antenna	3 m
30 MHz - 1 GHz	Trilog Broadband Antenna	3 m
1 GHz - 18 GHz	Double Ridged Horn Antenna (1 GHz - 18 GHz)	3 m
18 GHz - 40 GHz	Horn Antenna (18 GHz - 40 GHz)	1 m

According ANSI C63.10:2013 clause 6.4.4.2 and 6.5.3, for measurements below 30 MHz, the

loop antenna was positioned with its plane vertical from the EUT and rotated about its vertical axis for maximum response at each azimuth position around the EUT. And the loop antenna also is positioned with its plane horizontal at the specified distance from the EUT. The center of the loop is 1 m above the ground. For measurement above 30 MHz, the Trilog Broadband Antenna or Horn Antenna was located 3 m from EUT, Measurements were made with the antenna positioned in both the horizontal and vertical planes of Polarization, and the measurement antenna was varied from 1 m to 4 m. in height above the reference ground plane to obtain the maximum signal strength.

(4) Below pre-scan procedure was first performed in order to find prominent frequency spectrum radiated emissions from 9 kHz to 40 GHz:

(a) Scanning the peak frequency spectrum with the antenna specified in step (3), and the EUT was rotated 360 degree, the antenna height was varied from 1 m to 4 m (Except loop antenna, it's fixed 1 m above ground.)

(b) Change work frequency or channel of device if practicable.

(c) Change modulation type of device if practicable.

(d) Change power supply range from 85% to 115% of the rated supply voltage

(e) Rotated EUT though three orthogonal axes to determine the attitude of EUT arrangement produces highest emissions. Spectrum frequency from 9 kHz to 40 GHz (tenth harmonic of fundamental frequency) was investigated, and no any obvious emission were detected from 9 kHz to 30 MHz and 18 GHz to 40 GHz, so below final test was performed with frequency range from 30 MHz to 18 GHz.

(5) For final emissions measurements at each frequency of interest, the EUT was rotated and the antenna height was varied between 1 m and 4 m in order to maximize the emission. Measurements in both horizontal and vertical polarities were made and the data was recorded. In order to find the maximum emission, the relative positions of equipments and all of the interface cables were changed according to ANSI C63.10:2013 on Radiated Emission test.

(6) The emissions from 9 kHz to 1 GHz were measured based on CISPR QP detector except for the frequency bands 9 - 90 kHz, 110 - 490 kHz, for emissions from 9 kHz - 90 kHz, 110 kHz - 490 kHz and above 1 GHz were measured based on average detector, for emissions above 1 GHz, peak emissions also be measured and need comply with Peak limit.

(7) The emissions from 9 kHz to 1 GHz, QP or average values were measured with EMI receiver with below RBW

Frequency band	RBW
9 kHz - 150 kHz	200 Hz
150 kHz - 30 MHz	9 kHz
30 MHz - 1 GHz	120 kHz

(8) For emissions above 1 GHz, both Peak and Average level were measured with Spectrum

Analyzer, and the RBW is set at 1 MHz, VBW is set at 3 MHz for Peak measure, according ANSI C63.10:2013 clause 4.1.4.2.2 procedure for average measure.

8.4. Test result

Pass. (See below detailed test result)

All the emissions except fundamental emission from 9 kHz to 40 GHz were comply with 15.209 limit.

Note1: According exploratory test, the emission levels are 20 dB below the limit detected from 9 kHz to 30 MHz and 18 GHz to 40 GHz, so the final test was performed with frequency range from 30 MHz to 18 GHz and recorded in below.

Note2: For emissions below 1 GHz, according exploratory explorer test, when change Tx mode and channel, have no distinct influence on emissions level, so for emissions below 1 GHz, the final test was only performed with EUT working in 11ax mode.

Note3: For below test data, when the limit tabular marked “/” means this frequency point is the fundamental emission and no need comply with this limit.

Radiated Emission test (below 1 GHz) TR-4-E-009 Radiated Emission Test Result

D:\2021 RE2# Report Data\Q21053108-1E UNR032H\FCC BELOW1G.EM6

Test Site : DDT 3m Chamber 2#	Tested By : Zora
Test Date : 2021-06-04	Model Number : UNR032H
EUT : WiFi6 CPE	Test Mode : Tx mode
Power Supply : AC 120V/60Hz	Antenna/Distance : 2020 VULB 9163 2#/3m/HORIZONTAL
Condition : Temp:24.5°C,Humi:55%,Press:100.1kPa	
Memo :	

Data: 5

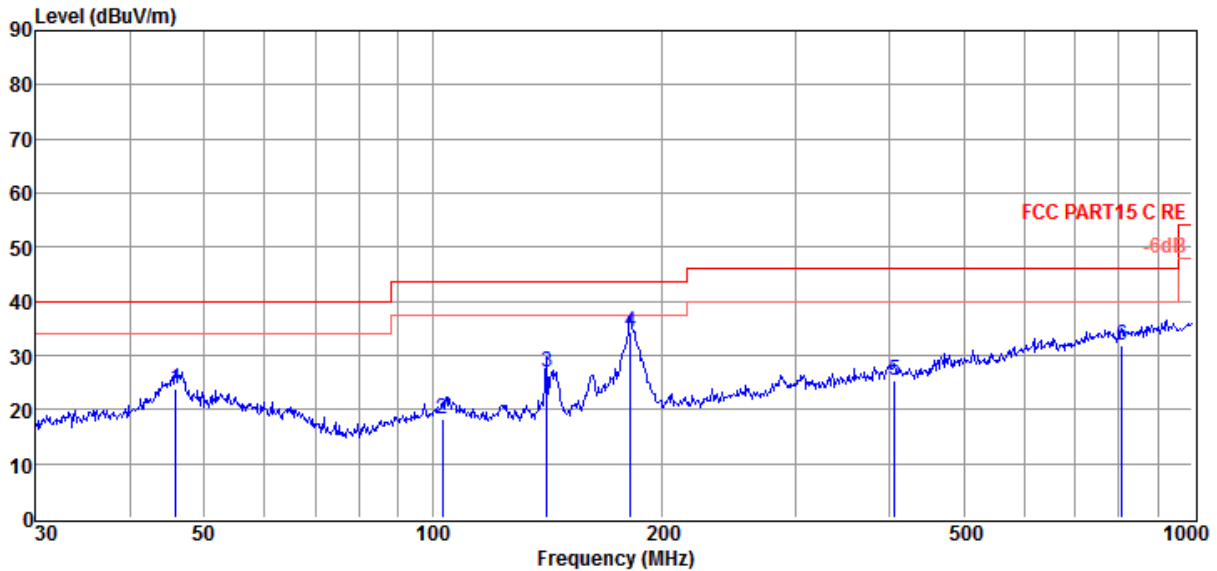

Item (Mark)	Freq. (MHz)	Read Level (dBμV)	Antenna Factor (dB/m)	PRM Factor dB	Cable Loss dB	Result Level (dBμV/m)	Limit Line (dBμV/m)	Over Limit (dB)	Detector	Polarization
1	45.86	7.18	12.91	0.00	3.82	23.91	40.00	-16.09	QP	HORIZONTAL
2	103.08	1.74	12.08	0.00	4.43	18.25	43.50	-25.25	QP	HORIZONTAL
3	141.33	14.44	7.63	0.00	4.70	26.77	43.50	-16.73	QP	HORIZONTAL
4	181.92	20.10	9.42	0.00	4.94	34.46	43.50	-9.04	QP	HORIZONTAL
5	406.09	3.91	15.53	0.00	5.94	25.38	46.00	-20.62	QP	HORIZONTAL
6	807.43	3.58	20.96	0.00	7.38	31.92	46.00	-14.08	QP	HORIZONTAL

Note: 1. Result Level = Read Level + Antenna Factor + Cable loss - PRM Factor.
 2. If Peak Result complies with QP limit, QP Result is deemed to comply with QP limit.
 3. Test setup: RBW: 120 kHz, VBW: 300 kHz, Sweep time: auto.

TR-4-E-009 Radiated Emission Test Result

Test Site : DDT 3m Chamber 2# D:\2021 RE2# Report Data\Q21053108-1E UNR032HFCC BELOW1G.EM6
Test Date : 2021-06-04 **Tested By** : Zora
EUT : WiFi6 CPE **Model Number** : UNR032H
Power Supply : AC 120V/60Hz **Test Mode** : Tx mode
Condition : Temp:24.5°C,Humi:55%,Press:100.1kPa **Antenna/Distance** : 2020 VULB 9163 2#/3m/VERTICAL

Memo :

Data: 6

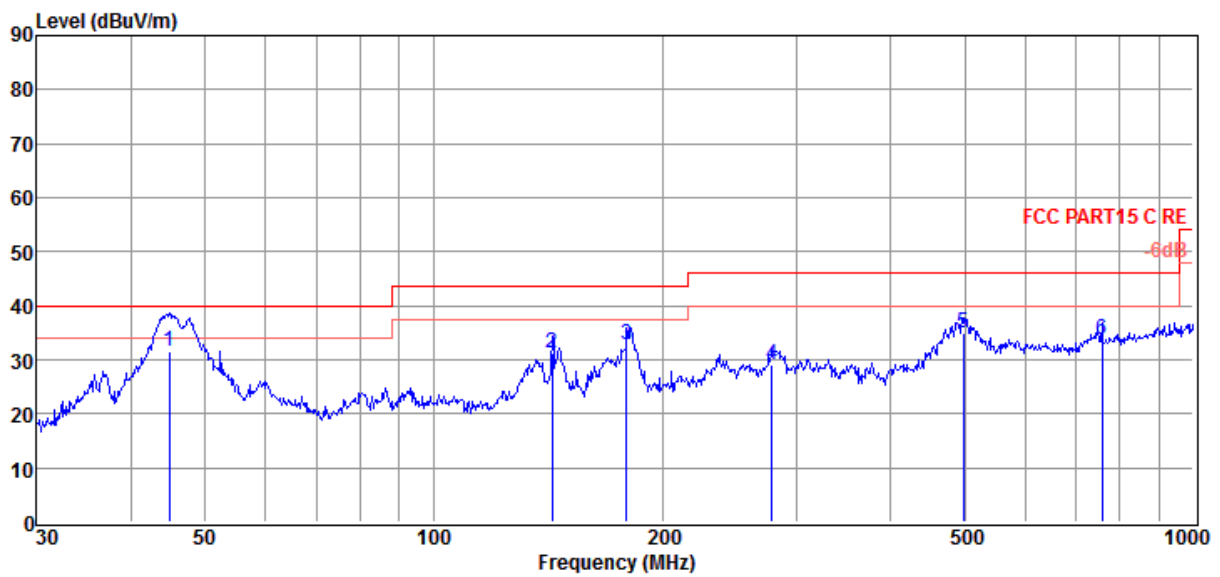

Item (Mark)	Freq. (MHz)	Read Level (dBμV)	Antenna Factor (dB/m)	PRM Factor (dB)	Cable Loss (dB)	Result Level (dBμV/m)	Limit Line (dBμV/m)	Over Limit (dB)	Detector	Polarization
1	44.90	14.85	12.99	0.00	3.81	31.65	40.00	-8.35	QP	VERTICAL
2	143.33	18.83	7.67	0.00	4.71	31.21	43.50	-12.29	QP	VERTICAL
3	179.39	18.83	9.16	0.00	4.93	32.92	43.50	-10.58	QP	VERTICAL
4	279.04	11.06	12.69	0.00	5.40	29.15	46.00	-16.85	QP	VERTICAL
5	497.68	11.90	16.68	0.00	6.28	34.86	46.00	-11.14	QP	VERTICAL
6	758.04	5.80	20.82	0.00	7.24	33.86	46.00	-12.14	QP	VERTICAL

Note: 1. Result Level = Read Level + Antenna Factor + Cable loss - PRM Factor.

2. If Peak Result complies with QP limit, QP Result is deemed to comply with QP limit.

3. Test setup: RBW: 120 kHz, VBW: 300 kHz, Sweep time: auto.

Radiated Emission test (above 1 GHz)

Freq (MHz)	Read level (dB μ V)	Antenna Factor (dB/m)	PRM Factor (dB)	Cable Loss (dB)	Result Level (dB μ V/m)	Limit (dB μ V/m)	Margin (dB)	Detector type	Polarization
11a CH149									
8055.00	46.36	37.91	42.27	8.65	50.65	74.00	-23.35	Peak	HORIZONTAL
11064.00	45.40	39.80	42.80	10.64	53.04	74.00	-20.96	Peak	HORIZONTAL
12645.00	44.54	39.13	42.45	11.82	53.04	74.00	-20.96	Peak	HORIZONTAL
14685.00	43.97	40.97	41.95	12.43	55.42	74.00	-18.58	Peak	HORIZONTAL
14685.00	34.76	40.97	41.95	12.43	46.21	54.00	-7.79	Average	HORIZONTAL
17949.00	41.93	47.79	42.49	14.51	61.74	74.00	-12.26	Peak	HORIZONTAL
17949.00	30.19	47.79	42.49	14.51	50.00	54.00	-4.00	Average	HORIZONTAL
8021.00	47.21	37.90	42.29	8.64	51.46	74.00	-22.54	Peak	VERTICAL
10061.00	46.75	38.90	42.24	10.29	53.70	74.00	-20.30	Peak	VERTICAL
12849.00	45.49	39.46	42.77	11.44	53.62	74.00	-20.38	Peak	VERTICAL
15416.00	43.09	39.73	41.95	12.50	53.37	74.00	-20.63	Peak	VERTICAL
17881.00	41.80	47.50	42.47	14.35	61.18	74.00	-12.82	Peak	VERTICAL
17881.00	30.04	47.50	42.47	14.35	49.42	54.00	-4.58	Average	VERTICAL
Conclusion: Pass									
Note: $-27 \text{ dBm/MHz Limit} = 95.2 + \text{EIRP}[\text{dBm}] = 95.2 - 27 = 68.2 \text{ dB}\mu\text{V/m}$ For transmitters operating in the 5150 MHz - 5250 MHz, 5250 MHz - 5350 MHz, 5470 MHz - 5725 MHz, 5725 MHz - 5850 MHz band: all emissions outside of the 5.15-5.35 GHz band shall not exceed an EIRP of -27 dBm/MHz.									

Note: 1. Result Level = Read Level + Antenna Factor + Cable loss - PRM Factor.

2. Test setup: RBW: 1 MHz, VBW: 3 MHz, Sweep time: auto.

3. All the emissions were comply with 54 dB μ V/m for Average value in 15.209, so both for the restricted bands and non-restricted bands, all the emissions were comply with the limit.

9. Band Edge Compliance

9.1. Block diagram of test setup

Radiated measurement:

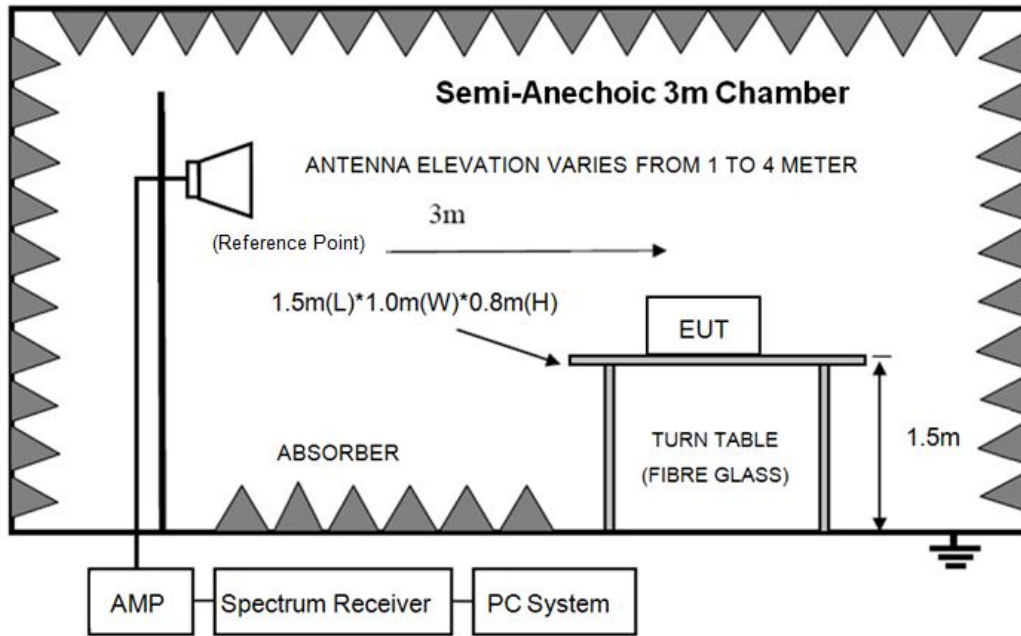

Conducted measurement:

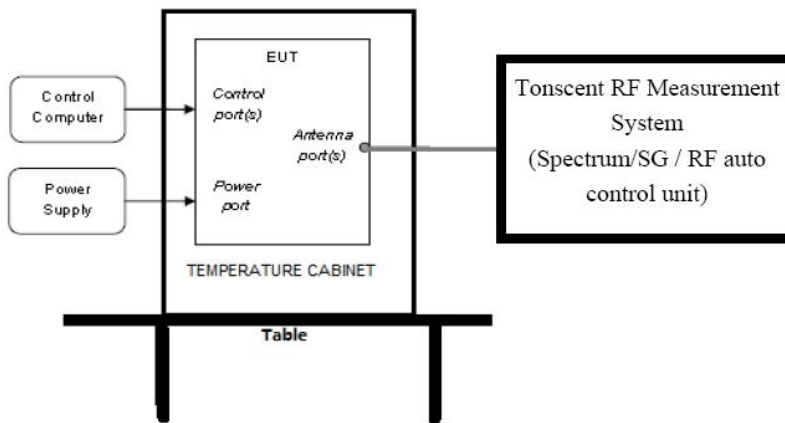

9.2. Limit

For transmitters operating in the 5.15 - 5.25 GHz and 5.725 - 5.85 GHz band: all emissions outside of the 5.15 - 5.35 GHz band shall not exceed an EIRP of -27 dBm/MHz.

$$-27 \text{ dBm/MHz Limit} = 95.2 + \text{EIRP}[\text{dBm}] = 95.2 - 27 = 68.2 \text{ dB}\mu\text{V/m}$$

9.3. Test procedure

Same with clause 8.3 except change investigated frequency range from 5.15 - 5.25 GHz, 5250 - 5350 GHz, 5470 - 5725 GHz, 5.725 - 5.85 GHz.

Remark: All restriction band have been tested, and only the worst case is shown in report.

9.4. Test result

Pass. (See below detailed test result)

Note: As specified in 15.407(b), emissions above 1000 MHz that are outside of the restricted bands are subject to a peak emission limit of -27 dBm/MHz (or -17 dBm/MHz as specified in 15.407(b)(4)). However, an out-of-band emission that complies with both the average and peak limits of 15.209 is not required to satisfy the -27 dBm/MHz or -17 dBm/MHz peak emission limit.

TR-4-E-009 Radiated Emission Test Result

Test Site : DDT 3m Chamber 2#

D:\2021 RE2# Report Data\Q21053108-1E UNR032HFCC
ABOVE 1G 2.4G.EM6

Test Date : 2021-06-08

Tested By : Zora

EUT : WiFi6 CPE

Model Number : UNR032H

Power Supply : AC 120V/60Hz

Test Mode : Tx mode

Condition : Temp:24.5°C,Humi:55%,Press:100.1kPa **Antenna/Distance** : 2020 BBHA9120D/3m/HORIZONTAL

Memo : 11AX 80M 5210

Data: 5

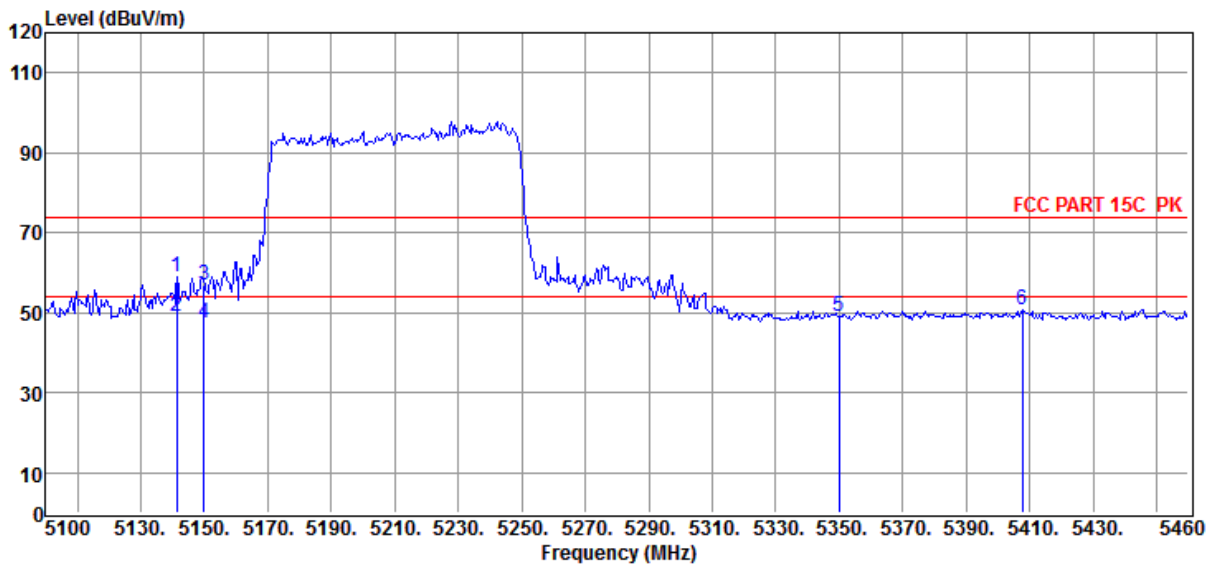

Item (Mark)	Freq. (MHz)	Read Level (dBμV)	Antenna Factor (dB/m)	PRM Factor (dB)	Cable Loss (dB)	Result Level (dBμV/m)	Limit Line (dBμV/m)	Over Limit (dB)	Detector	Polarization
1	5141.40	62.60	32.76	43.25	7.06	59.17	74.00	-14.83	Peak	HORIZONTAL
2	5141.40	52.39	32.76	43.25	7.06	48.96	54.00	-5.04	Average	HORIZONTAL
3	5150.00	60.38	32.76	43.25	7.06	56.95	74.00	-17.05	Peak	HORIZONTAL
4	5150.00	50.87	32.76	43.25	7.06	47.44	54.00	-6.56	Average	HORIZONTAL
5	5350.00	52.45	32.84	43.31	7.10	49.08	74.00	-24.92	Peak	HORIZONTAL
6	5407.80	53.88	32.86	43.33	7.11	50.52	74.00	-23.48	Peak	HORIZONTAL

- Note: 1. Result Level = Read Level + Antenna Factor + Cable loss - PRM Factor.
 2. If Peak Result complies with AV limit, AV Result is deemed to comply with AV limit.
 3. Test setup: RBW: 1 MHz, VBW: 3 MHz, Sweep time: auto.

TR-4-E-009 Radiated Emission Test Result

Test Site : DDT 3m Chamber 2#

D:\2021 RE2# Report Data\Q21053108-1E UNR032HFCC ABOVE 1G 2.4G.EM6

Test Date : 2021-06-08

Tested By : Zora

EUT : WiFi6 CPE

Model Number : UNR032H

Power Supply : AC 120V/60Hz

Test Mode : Tx mode

Condition : Temp:24.5°C,Humi:55%,Press:100.1kPa **Antenna/Distance** : 2020 BBHA9120D/3m/VERTICAL

Memo : 11AX 80M 5210

Data: 6

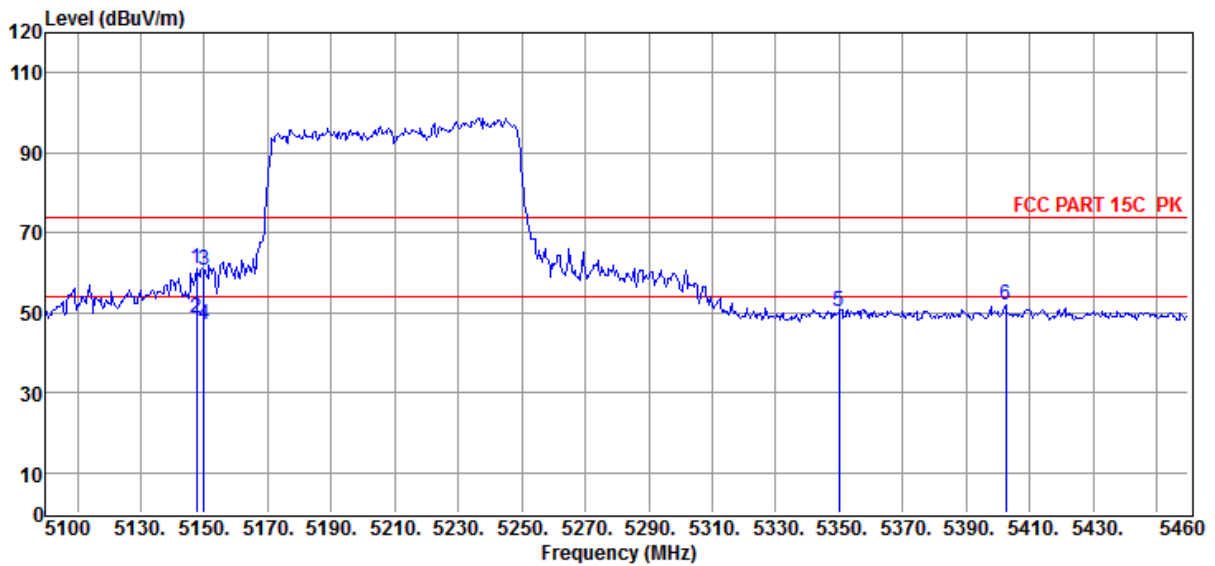

Item (Mark)	Freq. (MHz)	Read Level (dBμV)	Antenna Factor (dB/m)	PRM Factor (dB)	Cable Loss (dB)	Result Level (dBμV/m)	Limit Line (dBμV/m)	Over Limit (dB)	Detector	Polarization
1	5147.52	64.55	32.76	43.25	7.06	61.12	74.00	-12.88	Peak	VERTICAL
2	5147.52	52.15	32.76	43.25	7.06	48.72	54.00	-5.28	Average	VERTICAL
3	5150.00	63.86	32.76	43.25	7.06	60.43	74.00	-13.57	Peak	VERTICAL
4	5150.00	50.38	32.76	43.25	7.06	46.95	54.00	-7.05	Average	VERTICAL
5	5350.00	53.70	32.84	43.31	7.10	50.33	74.00	-23.67	Peak	VERTICAL
6	5402.40	55.34	32.86	43.33	7.10	51.97	74.00	-22.03	Peak	VERTICAL

Note: 1. Result Level = Read Level + Antenna Factor + Cable loss - PRM Factor.

2. If Peak Result complies with AV limit, AV Result is deemed to comply with AV limit.

3. Test setup: RBW: 1 MHz, VBW: 3 MHz, Sweep time: auto.

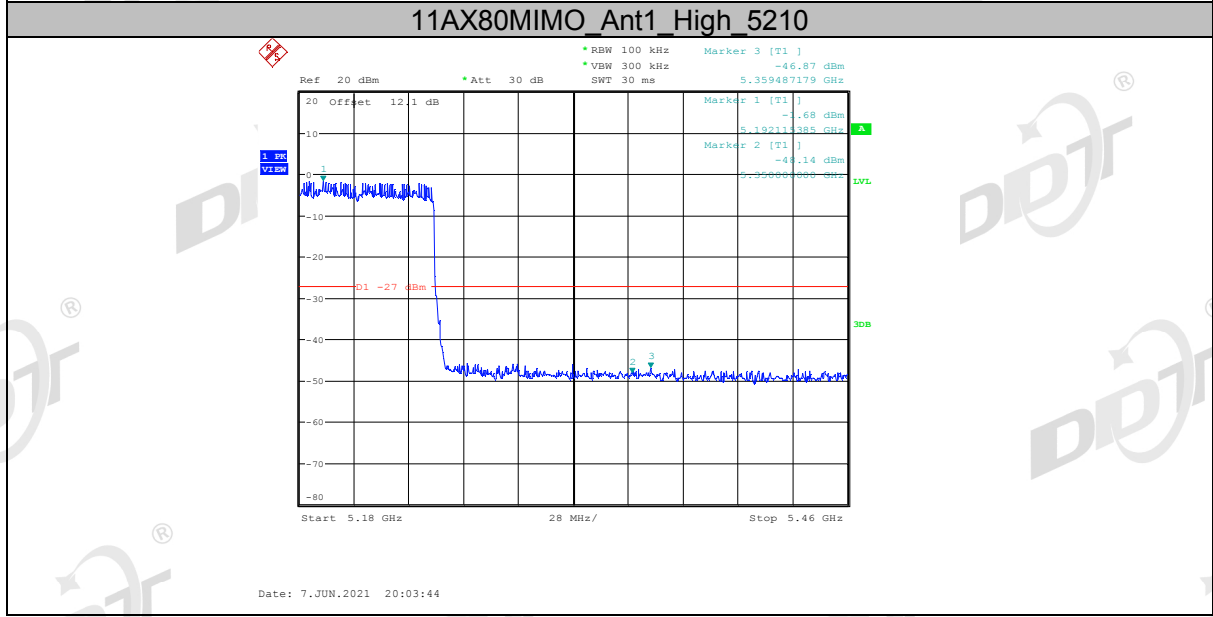
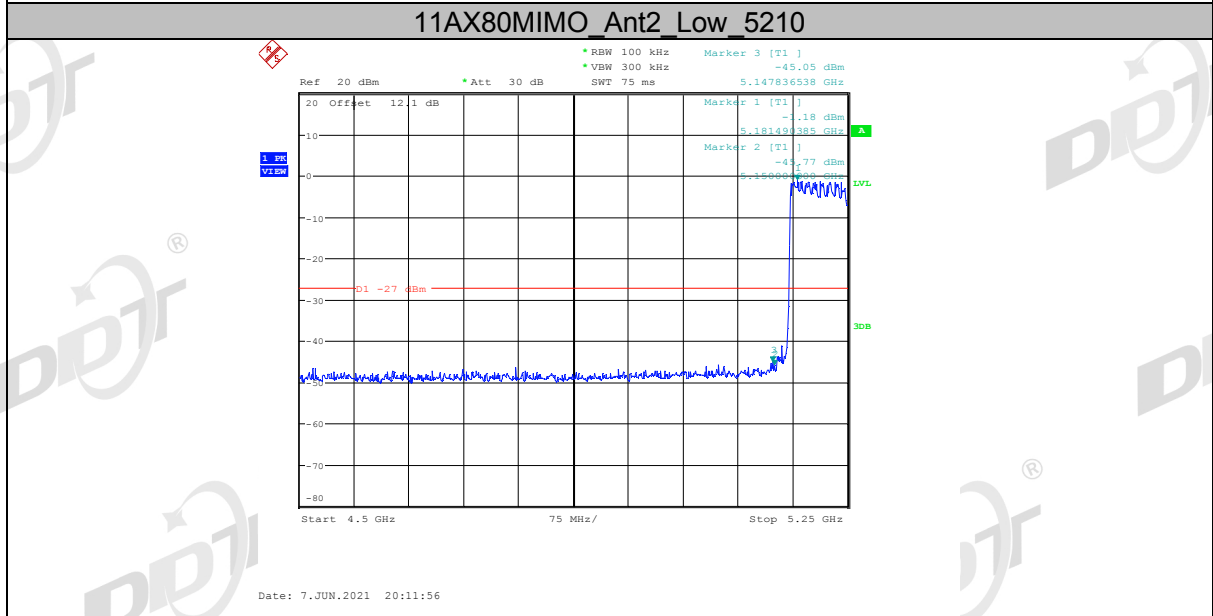
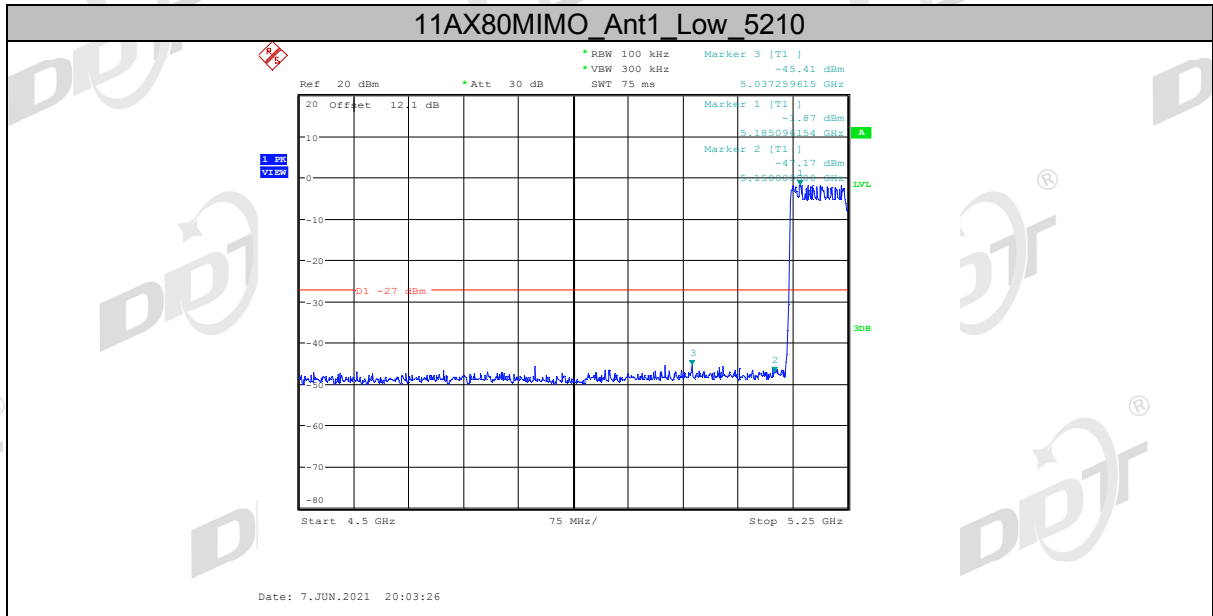

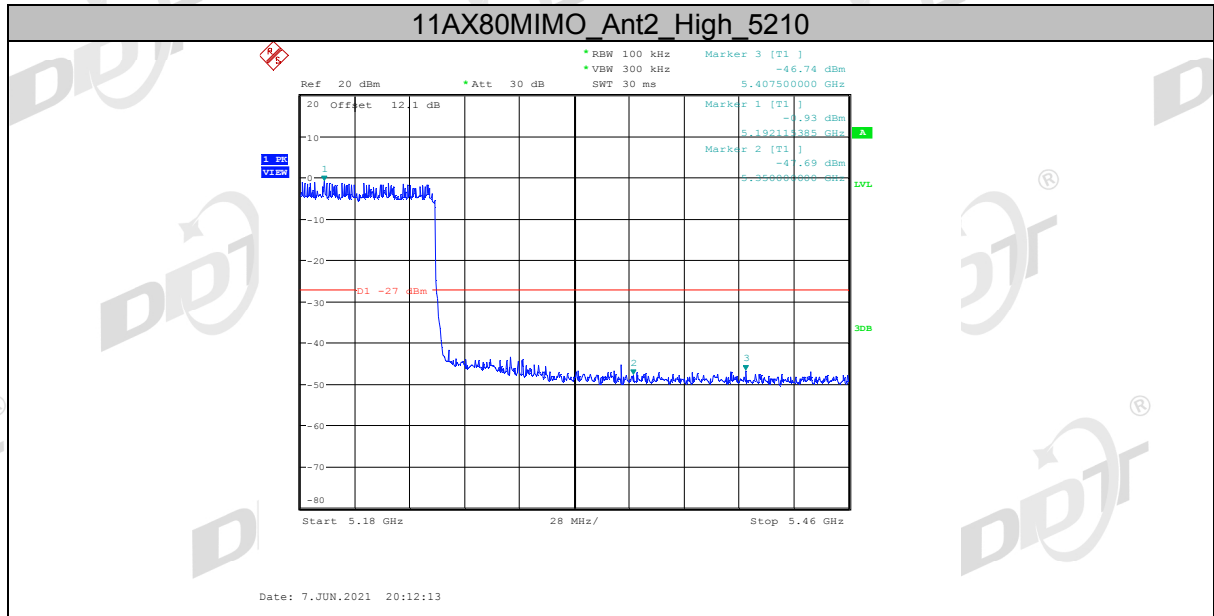

10. Power Line Conducted Emission

10.1. Block diagram of test setup

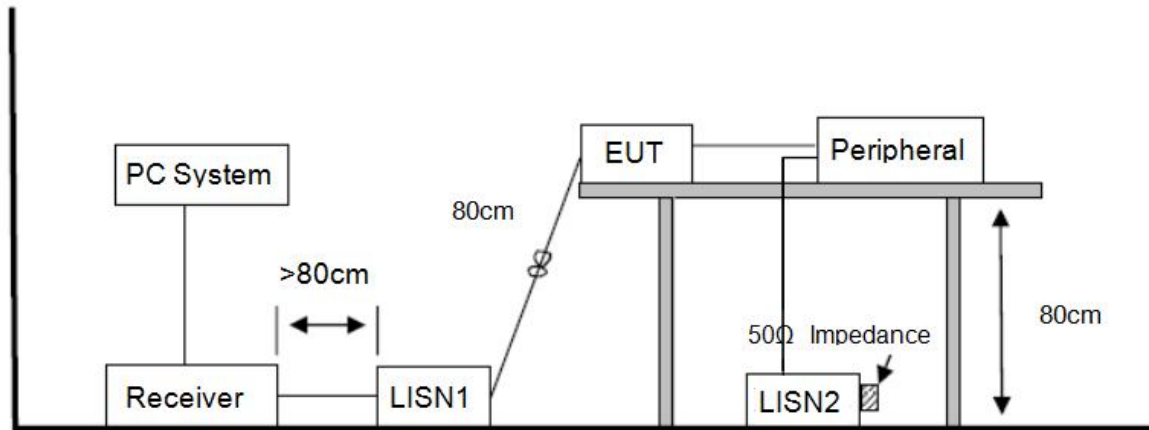

10.2. Power line conducted emission limits (Class B)

Frequency	Quasi-Peak Level dB(μ V)	Average Level dB(μ V)
150 kHz ~ 500 kHz	66 ~ 56*	56 ~ 46*
500 kHz ~ 5 MHz	56	46
5 MHz ~ 30 MHz	60	50

Note 1: * Decreasing linearly with logarithm of frequency.

Note 2: The lower limit shall apply at the transition frequencies.

10.3. Test procedure

The EUT and Support equipment, if needed, were put placed on a non-metallic table, 80cm above the ground plane.

Configuration EUT to simulate typical usage as described in clause 2.3 and test equipment as described in clause 10.2 of this report.

All I/O cables were positioned to simulate typical actual usage as per ANSI C63.4.

All support equipment power received from a second LISN.

Emissions were measured on each current carrying line of the EUT using an EMI Test Receiver connected to the LISN powering the EUT.

The Receiver scanned from 150 kHz to 30 MHz for emissions in each of the test modes.

During the above scans, the emissions were maximized by cable manipulation.

The test mode(s) described in clause 2.3 were scanned during the preliminary test.

After the preliminary scan, we found the test mode producing the highest emission level.

The EUT configuration and worse cable configuration of the above highest emission levels were recorded for reference of the final test.
EUT and support equipment were set up on the test bench as per the configuration with highest emission level in the preliminary test.

A scan was taken on both power lines, Neutral and Line, recording at least the six highest emissions.

Emission frequency and amplitude were recorded into a computer in which correction factors were used to calculate the emission level and compare reading to the applicable limit.

The test data of the worst-case condition(s) was recorded.

The bandwidth of test receiver is set at 9 kHz.

10.4. Test result

Pass. (See below detailed test result)

Note1: All emissions not reported below are too low against the prescribed limits.

Note2: "----" means peak detection; "----" means average detection

Note3: Pre-test AC conducted emission at both voltage AC 120V/60Hz and AC 240V/50Hz, recorded worse case.

TR-4-E-010 Conducted Emission Test Result

Test Site : DDT 5# Shield Room D:\2021 report data\Q21053108-1E UNR032HVCE.EM6
Test Date : 2021-06-09 **Tested By** : Junchang Du
EUT : WiFi6 CPE **Model Number** : UNR032H
Power Supply : AC 120V/60Hz **Test Mode** : Tx mode
Condition : Temp:24.5°C,Humi:55.5%,Press:101.4kPa **LISN** : 2020 ENV 216 2#/NEUTRAL
Memo :
 Data: 2

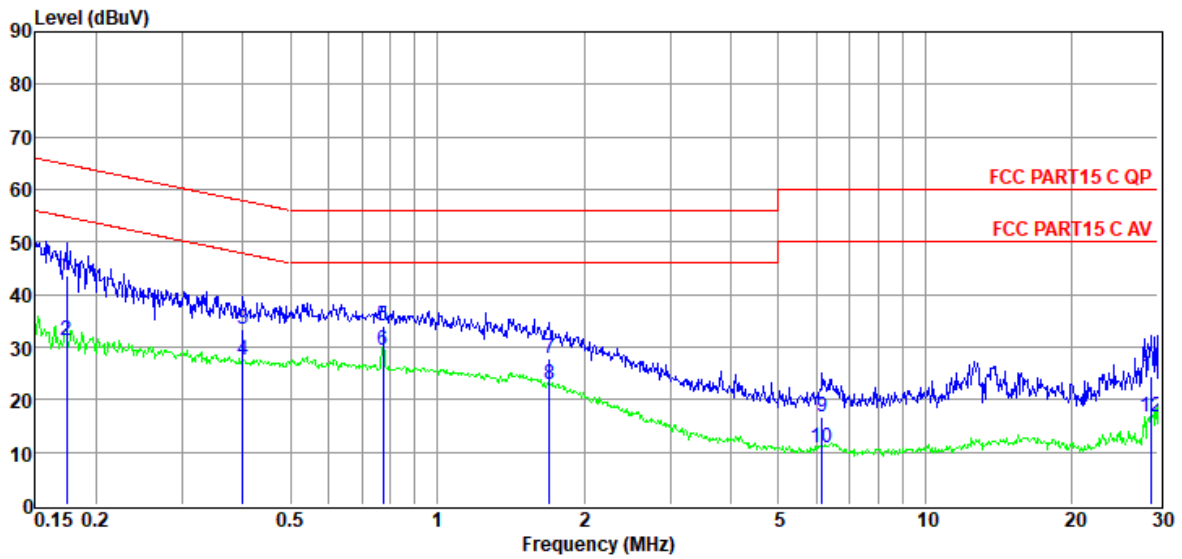

Item (Mark)	Freq. (MHz)	Read Level (dBμV)	LISN Factor (dB)	Cable Loss (dB)	Pulse Limiter Factor (dB)	Result Level (dBμV)	Limit Line (dBμV)	Over Limit (dB)	Detector	Phase
1	0.17	24.07	9.39	0.02	10.01	43.49	64.77	-21.28	QP	NEUTRAL
2	0.17	11.71	9.39	0.02	10.01	31.13	54.77	-23.64	Average	NEUTRAL
3	0.40	13.85	9.40	0.02	10.01	33.28	57.86	-24.58	QP	NEUTRAL
4	0.40	8.01	9.40	0.02	10.01	27.44	47.86	-20.42	Average	NEUTRAL
5	0.78	14.65	9.40	0.03	10.01	34.09	56.00	-21.91	QP	NEUTRAL
6	0.78	10.09	9.40	0.03	10.01	29.53	46.00	-16.47	Average	NEUTRAL
7	1.70	8.48	9.41	0.05	10.01	27.95	56.00	-28.05	QP	NEUTRAL
8	1.70	3.41	9.41	0.05	10.01	22.88	46.00	-23.12	Average	NEUTRAL
9	6.15	-2.83	9.51	0.09	10.01	16.78	60.00	-43.22	QP	NEUTRAL
10	6.15	-8.82	9.51	0.09	10.01	10.79	50.00	-39.21	Average	NEUTRAL
11	29.06	4.73	9.53	0.19	10.03	24.48	60.00	-35.52	QP	NEUTRAL
12	29.06	-3.18	9.53	0.19	10.03	16.57	50.00	-33.43	Average	NEUTRAL

Note: 1. Result Level = Read Level + LISN Factor + Pulse Limiter Factor + Cable loss.
 2. If QP Result complies with AV limit, AV Result is deemed to comply with AV limit.
 3. Test setup: RBW: 200 Hz (9 kHz—150 kHz), 9 kHz (150 kHz—30 MHz).
 4. Step size: 80Hz (0.009MHz-0.15MHz), 4 kHz (0.15MHz-30MHz), Scan time: auto.

TR-4-E-010 Conducted Emission Test Result

Test Site : DDT 5# Shield Room D:\2021 report data\Q21053108-1E UNR032HVCE.EM6
Test Date : 2021-06-09 **Tested By** : Junchang Du
EUT : WiFi6 CPE **Model Number** : UNR032H
Power Supply : AC 120V/60Hz **Test Mode** : Tx mode
Condition : Temp:24.5°C,Humi:55.5%,Press:101.4kPa **LISN** : 2020 ENV 216 2#/LINE
Memo :

Data: 4

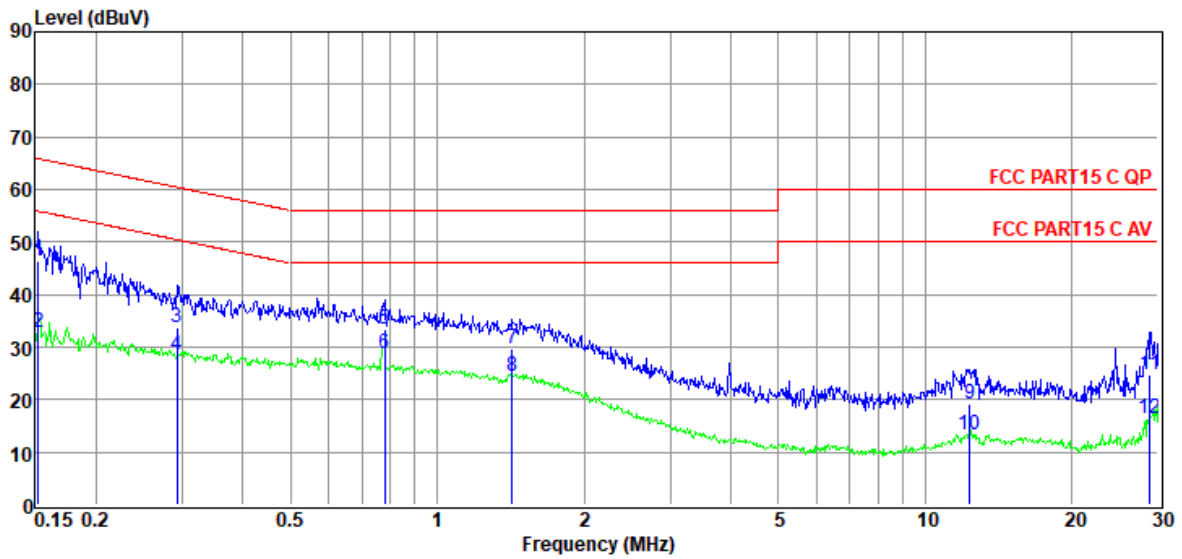

Item (Mark)	Freq. (MHz)	Read Level (dBμV)	LISN Factor (dB)	Cable Loss (dB)	Pulse Limiter Factor (dB)	Result Level (dBμV)	Limit Line (dBμV)	Over Limit (dB)	Detector	Phase
1	0.15	27.04	9.41	0.02	10.01	46.48	65.87	-19.39	QP	LINE
2	0.15	13.32	9.41	0.02	10.01	32.76	55.87	-23.11	Average	LINE
3	0.29	14.33	9.44	0.02	10.01	33.80	60.46	-26.66	QP	LINE
4	0.29	8.91	9.44	0.02	10.01	28.38	50.46	-22.08	Average	LINE
5	0.78	13.98	9.44	0.03	10.01	33.46	56.00	-22.54	QP	LINE
6	0.78	9.32	9.44	0.03	10.01	28.80	46.00	-17.20	Average	LINE
7	1.43	10.32	9.43	0.04	10.01	29.80	56.00	-26.20	QP	LINE
8	1.43	5.06	9.43	0.04	10.01	24.54	46.00	-21.46	Average	LINE
9	12.32	-0.53	9.62	0.12	10.01	19.22	60.00	-40.78	QP	LINE
10	12.32	-6.59	9.62	0.12	10.01	13.16	50.00	-36.84	Average	LINE
11	28.91	5.23	9.34	0.19	10.03	24.79	60.00	-35.21	QP	LINE
12	28.91	-3.23	9.34	0.19	10.03	16.33	50.00	-33.67	Average	LINE

- Note: 1. Result Level = Read Level + LISN Factor + Pulse Limiter Factor + Cable loss.
 2. If QP Result complies with AV limit, AV Result is deemed to comply with AV limit.
 3. Test setup: RBW: 200 Hz (9 kHz—150 kHz), 9 kHz (150 kHz—30 MHz).
 4. Step size: 80Hz (0.009MHz-0.15MHz), 4 kHz (0.15MHz-30MHz), Scan time: auto.

11. Antenna Requirements

11.1. Limit

For intentional device, according to FCC 47 CFR Section 15.203, an intentional radiator shall be designed to ensure that no antenna other than that furnished by the responsible party shall be used with the device. And according to FCC 47 CFR Section 15.407 (a), if transmitting antennas of directional gain greater than 6 dBi are used, the power shall be reduced by the amount in dB that the directional gain of the antenna exceeds 6 dBi.

11.2. Result

The antennas used for this product are external antenna support 2T2R MIMO mode and that no antenna other than that furnished by the responsible party shall be used with the device, the maximum peak gain is 6.01 dBi for 2T2R MIMO mode.

12. Test Setup Photograph



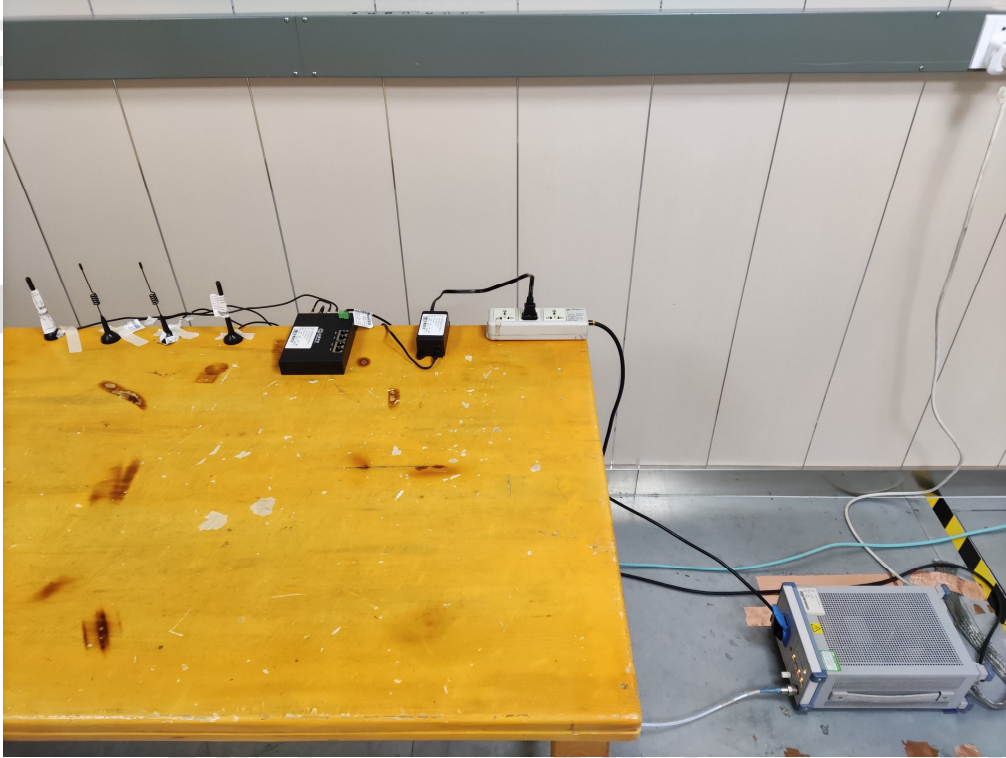

END OF REPORT