

尺寸：143*210mm

80克书纸

黑白印刷

PROSCAN

USER MANUAL



PEDPF1400

This product has been manufactured and sold under the responsibility of CURTIS INTERNATIONAL LTD.
PROSCAN, and the PROSCAN logo are trademarks used under license by CURTIS INTERNATIONAL LTD. – further information at www.proscan-brand.com.
All other products, services, companies, trademarks, trade or product names and logos referenced herein are the property of their respective owners.

ENGLISH

Please make sure to read this manual before using. Thank you!

CAUTION: To prevent electric shock, match wide blade of plug to wide slot, full insert.

WARNING: Changes or modifications to this unit not expressly approved by the party responsible for compliance could void the user's authority to operate the equipment.

WARNING: Shock hazard – Do Not Open.

WARNING: To reduce the risk of fire or electric shock, do not expose this device to rain, moisture, dripping, or splashing.

Do not use the sharp objects to click the screen or the touch screen may be damaged.

Do not drop or crash the device to prevent the display screen being defective.

Do not use a different type charger or it may make the device burned.

Do not disconnect the device while formatting. Please operate the device according to the user manual correctly and backup the important data in time.

Do not use this device where electronics are forbidden such as on the airplane.

Virus can damage this device. So please keep it updated to the newest software version.

Cleaning the LCD Screen:

Treat the screen carefully. The screen of the Wi-Fi Digital Picture Frame is made of glass and can be easily broken or scratched.

If fingerprints or dust accumulate on the LCD screen, we recommend using a lint - free, non-abrasive cloth such as a camera lens cloth to clean the LCD screen.

Moisten the cleaning cloth with the mild cleaner and apply the cloth to the screen

WARNING:

Please power off the unit before inserting or removing a card or USB device to avoid causing any damage to the card/USB and the unit. To reduce the risk of fire or electric shock do not expose this appliance to rain or moisture.

Introduction:

- Thank you for the purchase of this Wi-Fi Digital Picture Frame. With this frame it's simple and easy for you to view photos and videos received from your smartphone or from an external storage.
- Please read this User Manual carefully to learn the correct way to use the Wi-Fi Digital Picture Frame.

Features:

- 14.1 inch Wi-Fi Digital Picture Frame with touchscreen
- Send photos and videos from the free "Frameo" smartphone app - no matter where you are.
- Receive photos and videos from all your friends and family members.
- User-friendly interface and design make it super easy to use
- Quick and easy setup
- 32 GB of memory
- Set the display time to show each photo for 1 second to 24 hours.
- Timer function to make the photo frame turn off automatically at night
- Choose a reaction to your received photos and let your loved ones know what you think about the photos they've sent you
- Supports over 25 languages

Packaging Check List:

- | | |
|--------------------------------|---------|
| 1. 14.1" digital picture frame | 1 piece |
| 2. AC/DC adapter | 1 piece |
| 3. User Manual | 1 piece |
| 4. Wall mounting screw | 1 piece |
| 5. Stand | 1 piece |

CONTENTS

Warnings and Precautions	01
Introduction/Features/Packaging Check List.....	02
Contents	03
Product Diagram	04
Getting Started	05
Setting Up Your Frame.....	06
Adding a New Friend.....	08
Navigating your digital picture frame	10
Settings.....	13
Product specifications.....	25
Warranty card.....	26

Product Diagram

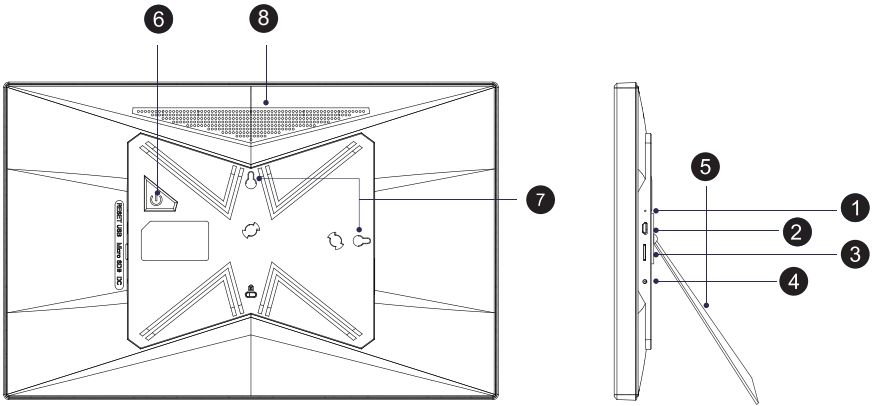

1.Reset

2.Micro USB Port

3.Micro SD Card Slot

4.DC Power Port

5. Stand

6.Power Button

7.Wall Mount Hole

8.Speakers

1.Reset

If the frame freezes or becomes unresponsive, use a pin or paperclip to reset the frame.

2.Micro USB Port

The micro USB port is only for software upgrading by the factory, not for charging or data transferring.

3.Micro SD Card Slot

Insert external microSD memory cards here to import photos, export photos or to play photos directly from the microSD card.

4.DC Power Port

Connect the DC adapter to power-on the device.

5.Stand

Use the plastic stand to hold the frame.

6.Power button

After connecting the power adapter, the unit will power-on automatically for the first time. When it is on, press and hold the power button for approximately 3 seconds to access the reboot and power-off menu.

Short press on the power button will turn off/on only the screen (but leave the photo frame turned on).

7.Wall Mount Hole

Use the screw to mount the frame on a wall - both portrait and landscape is possible.

8.Speakers

Equipped with two speakers.

Getting Started

Thank you for purchasing this Wi-Fi Digital Picture Frame with Frameo built-in. This user manual will help you get started with your new frame.

- 1 Extend the foldable stand and lay it flat, then plug one end of the AC adapter into a standard 110–240V AC power outlet, and plug the other end into the DC IN slot on the left side of the photo frame.

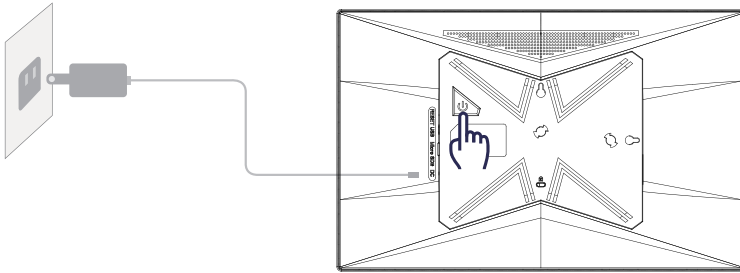

- 2 If you are new to using Frameo then start by following the Frameo Quick Setup when powering it on for the first time. Once you have set up your Frameo frame, you can start connecting it to your friends and family.

Frameo app

To send photos to your frame, use the Frameo app for iOS or Android.

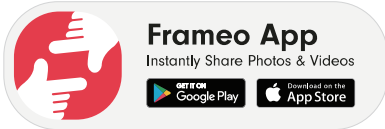

Scan code to find

Video tutorials

Check out the "Frameo Tutorials"- playlist on YouTube for informative walkthrough videos on how to get started using Frameo.



bit.ly/3zKtxWX

Setting Up Your Frame

When you switch on the frame for the first time, please follow below steps to set up the frame with Frameo app built-in. The below Frameo Quick Setup helps you to connect the frame with WiFi and create a frame ID.

1.Start by selecting the language you want to use.

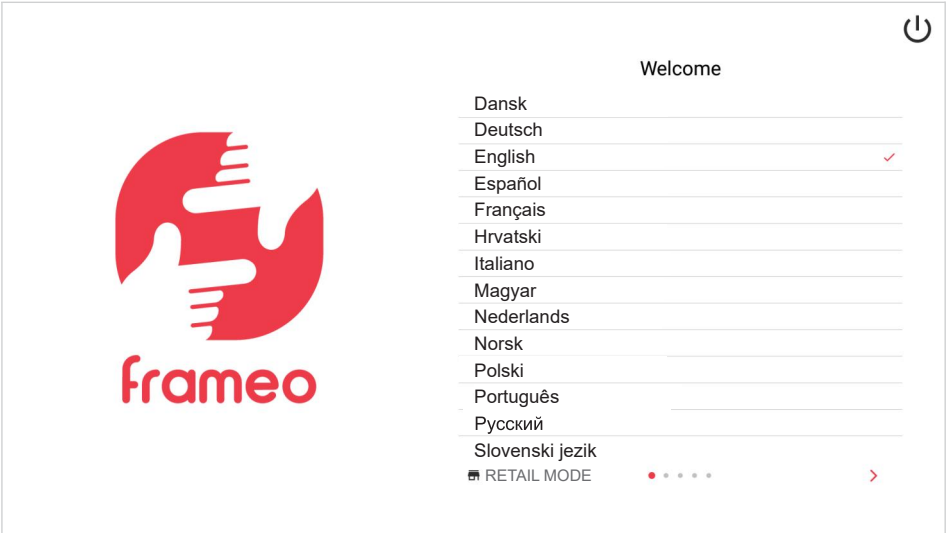

2.Connect to your Wi-Fi network by selecting it from the list and write your Wi-Fi password.

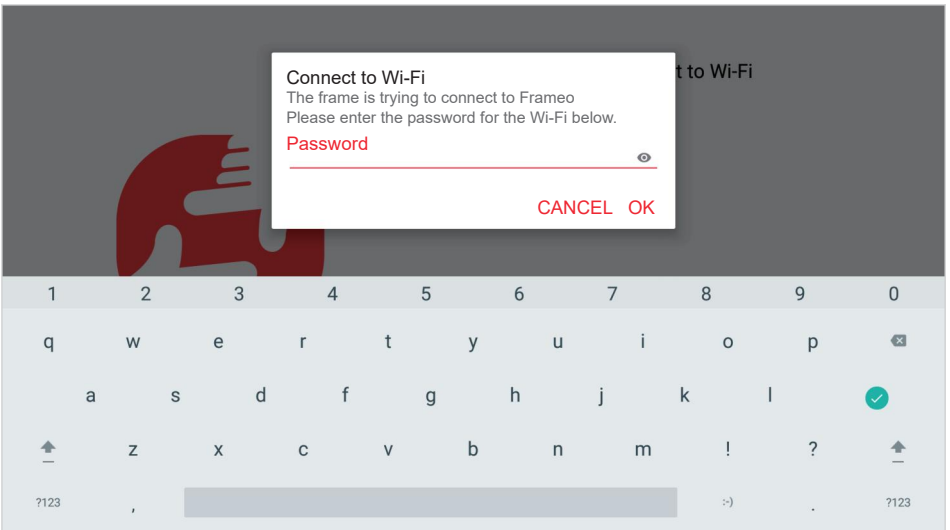

3. Verify or correct the date, time and timezone.

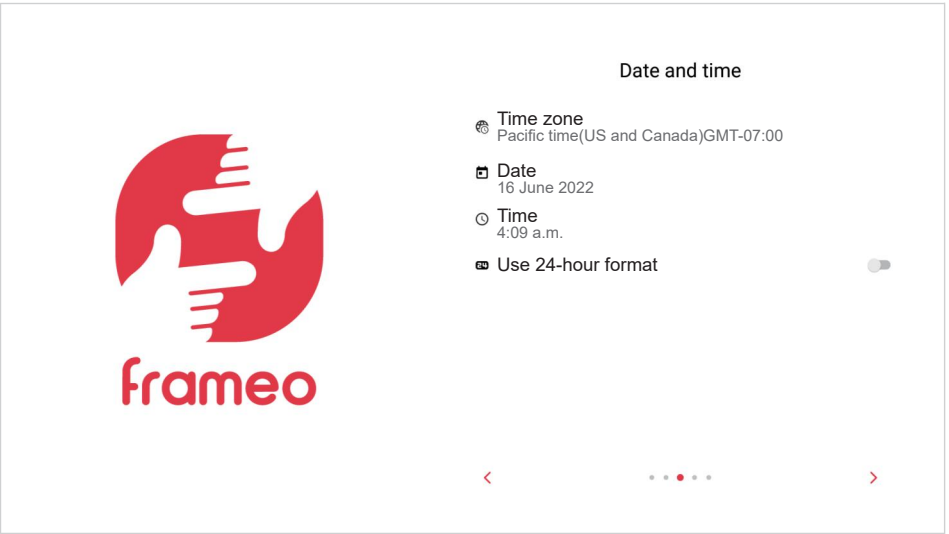

4. Your frame will check if a newer version of the Frameo software is available. We recommend you update your frame before continuing. Press "Download and install". It may take a few minutes depending on the speed of your Wi-Fi.

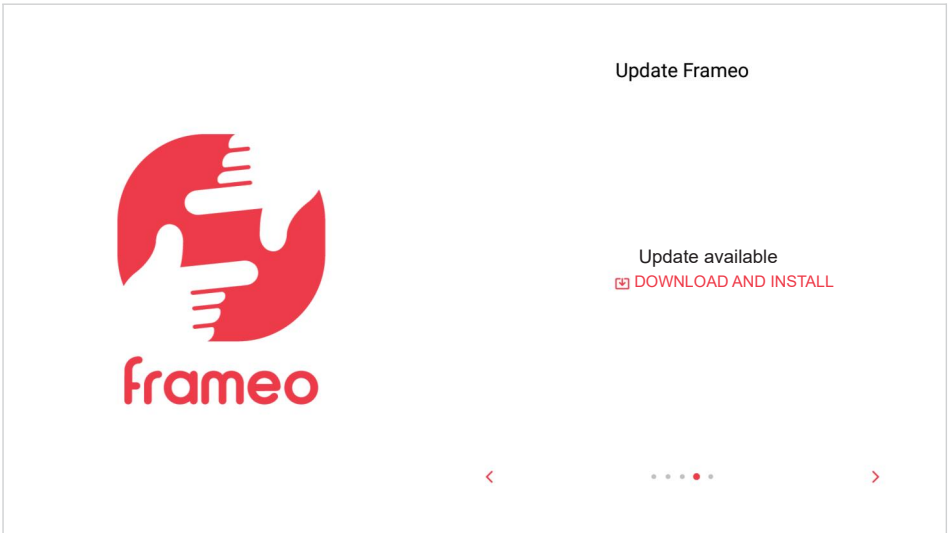

5. Finish the setup by entering your name, and the location where you have placed your frame e.g. "John Doe" and "Living room".

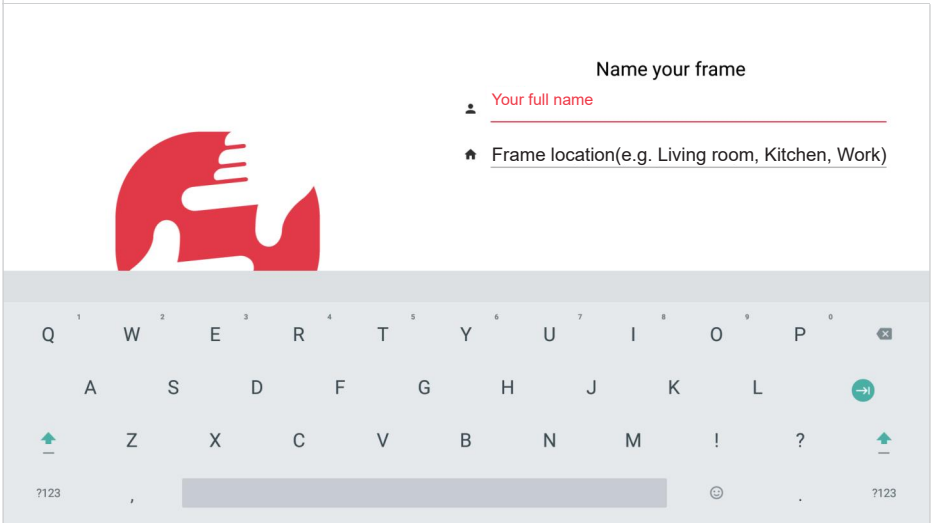

That's it!

Your frame is now all set up and you're ready to add your friends and family

Adding a New Friend

It's easy to add all your friends and family to your new frame, so they can send you photos and videos. Follow the steps below to add a new friend:

Steps on your frame

1. Tap the screen and click the "add friend" icon on your frame 

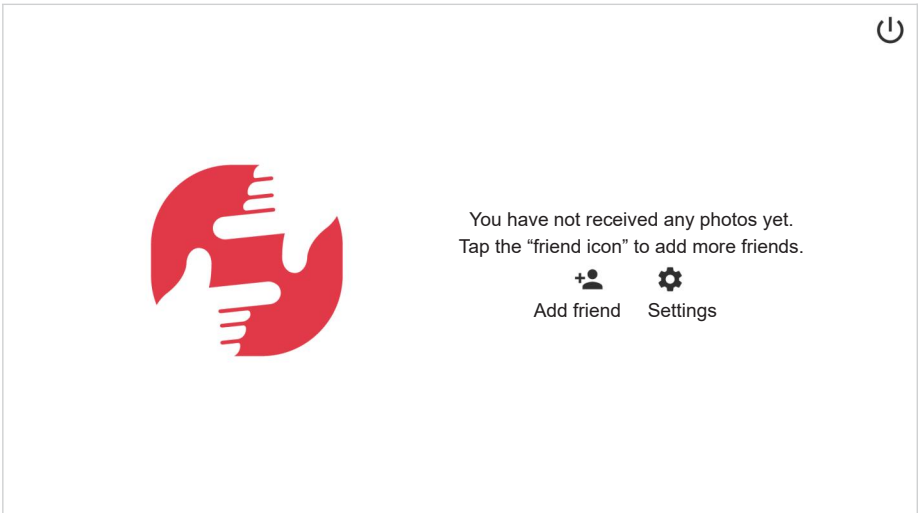

2. A unique connection code will appear, which is valid for 12 hours. Share this code with your friends and family. You can do this with a text message, an email or a phone call.

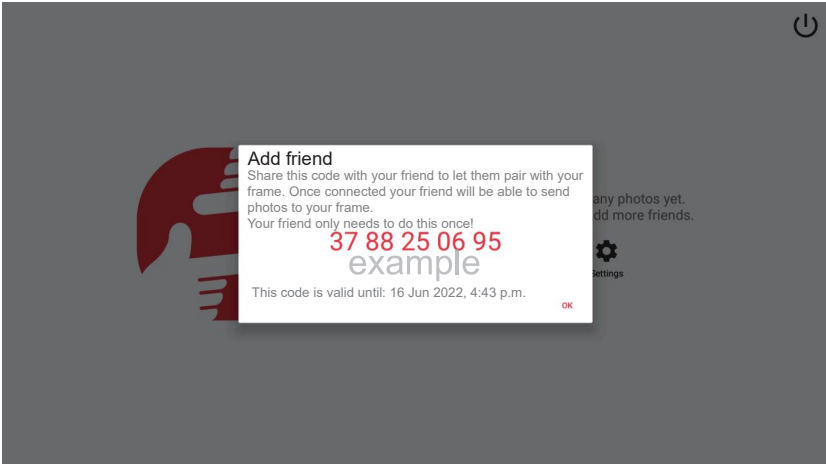

Steps in the Frameo smartphone app

1.

Your friends need to download and open the Frameo app and click the "add friend" icon in the top of the screen 

2.

Enter the code you shared with them earlier and press "Okay".

3.

Your friends are now connected to your frame and can send photos to your frame. They only have to connect one time.

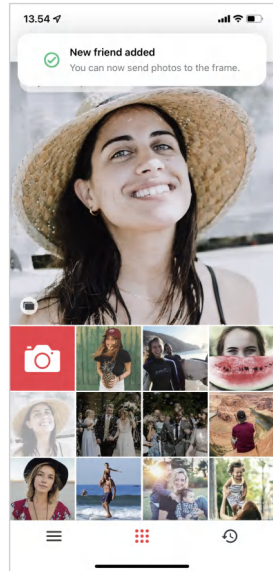
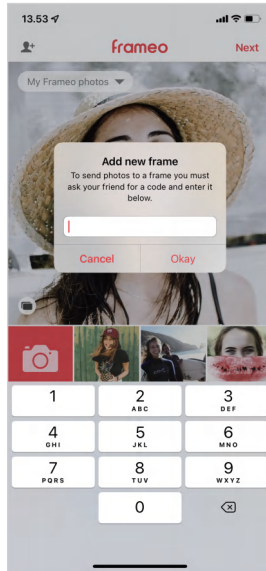
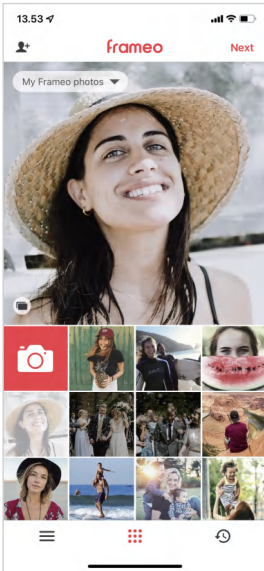

Navigating your digital picture frame

Your digital picture frame has a built-in touchscreen that makes it easy for everyone to use. Swipe left or right to go through all your photos.

To access the menu, simply tap once on the screen. In the menu you will find the most used features.

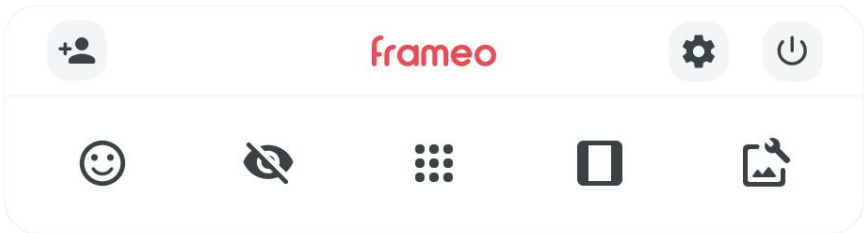

Add friend

This will generate a code that you can share with your friends and family so they can connect and send photos to your frame.

Settings

Opens the [Settings](#).

Power menu

Opens the [Power menu](#).

React

Opens the [React menu](#).

The React menu can also be accessed by double-tapping on the screen.

Hide photo

Hides the current photo. This means that the photo will no longer be shown in the slideshow. If needed the photo can be shown again through the [settings menu](#).

Gallery

Opens a gallery which allows for easy and fast navigation through your photos.

Fit to frame/Fill frame

This toggles how the photo is shown.



The Fill frame option is the default. The photo is scaled so that it fills the whole screen. It will be centered around what is selected as the most important part. See the first picture below.

Fit to frame will make sure that the entire photo is shown on the screen. See the second picture below.



Adjust photo

Allows you to adjust the position of the photo in the frame for an even better fit.

Here you can also use  to rotate your photo, and you can use  to edit the caption on imported photos. For received photos, please ask the sender to edit the caption in the Frameo app.

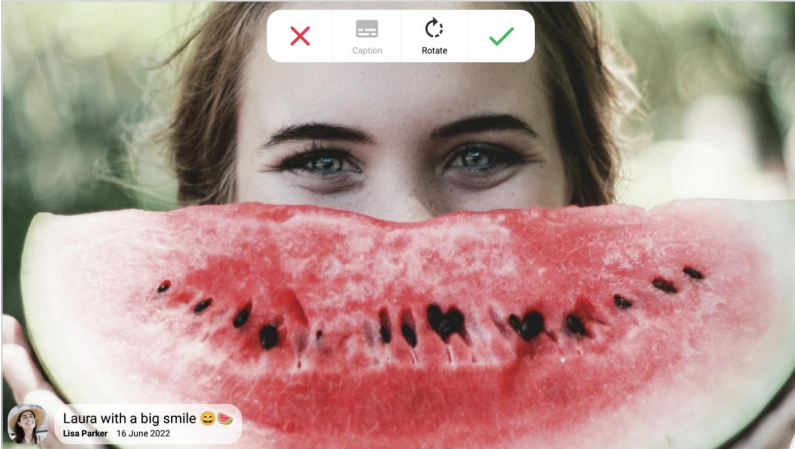

Play/Pause and Volume

Press  to start the video playback. Pressing  will pause the video playback.

Press  to open the volume slider. Use the slider to adjust the volume level for video sounds.

Press  will mute the video while pressing  will unmute the video.



Clock and Weather widgets

The current time and weather will appear in the upper-right corner of the frame when the frame has received at least one photo. Tapping either of these will open the weather menu.

Weather menu

The weather menu contains more detailed weather forecasts and has shortcuts to weather-related settings.



Shows the weather location of your frame. Tap to access the weather location settings.

1 DAY

1-day forecast which includes weather conditions for time periods of the day.





4 DAY

4-day forecast. Tap to see the weather forecast for the next four days.



Displays the frame's current time. Tap to access the time settings.

Power menu

Tap the power icon  to access the power menu. Here you can power off using  , restart your frame using  or enter sleep mode using .

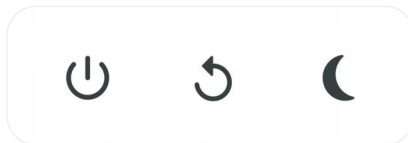



Make sure to always use the power off button on the device or in the power menu to turn Frameo off. Never disconnect power when Frameo is running.

React menu

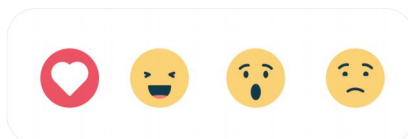
Tap one of the reactions to let the sender know how it made you feel.



External storage menu

After inserting an external storage (like a microSD card) a menu will automatically appear with three options: Play photos/videos directly from external storage using  , import photos onto the frame using  or backup the frame using .

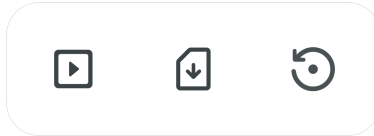

Settings

Use the settings to personalize your digital picture frame.

My frame

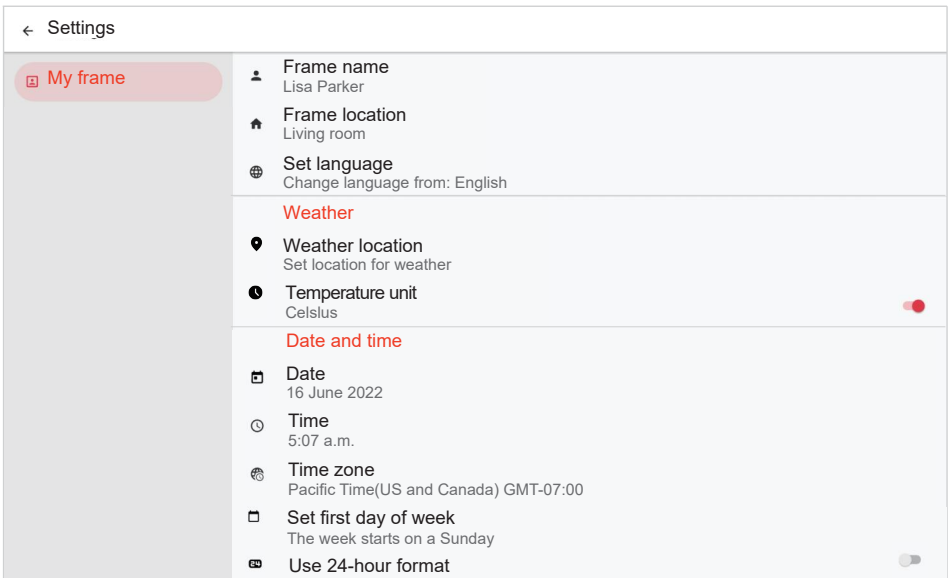
A screenshot of a settings application. At the top left is a back arrow and the text 'Settings'. Below this is a list of settings. The first item is 'My frame' with a red background. The second item is 'Frame name' with a person icon and the value 'Lisa Parker'. The third is 'Frame location' with a house icon and the value 'Living room'. The fourth is 'Set language' with a globe icon and the value 'Change language from: English'. Below these is a section header 'Weather'. The first item in this section is 'Weather location' with a location pin icon and the value 'Set location for weather'. The second is 'Temperature unit' with a thermometer icon and the value 'Celsius', with a red toggle switch to its right. Below this is a section header 'Date and time'. The first item is 'Date' with a calendar icon and the value '16 June 2022'. The second is 'Time' with a clock icon and the value '5:07 a.m.'. The third is 'Time zone' with a globe icon and the value 'Pacific Time(US and Canada) GMT-07:00'. The fourth is 'Set first day of week' with a calendar icon and the value 'The week starts on a Sunday'. The fifth is 'Use 24-hour format' with a speech bubble icon and a grey toggle switch to its right.

Frame name

Changes the name of your frame. This is also the name that connected friends and family will see in their list of connected frames in the smartphone app.

Frame location

Changes the location of your frame. This is the location displayed on your friend's list of connected frames which can help to distinguish frames from each other.

Set language

Sets the language used on the frame.

Weather location

Sets the location for the frame's weather feature, ensuring that your frame displays the appropriate weather forecast for you.

My Frame continued

Temperature unit

Toggles between the Fahrenheit and Celsius temperature scales.

Date

Sets the date used on the frame.

Time

Sets the time used on the frame.

Frameo will automatically try to set the correct date and time when connected to the internet.

Time zone

Sets the time zone used on the frame.

Set first day of week

Sets which day of the week is considered the first.

Enables, and disables, 24-hour time format.

Enables, and disables, 24-hour time format.

Manage photos

In the manage photos menu you can see how many photos are on your frame and the storage they use. You can also see the amount of storage left available on your device for storing new photos.

← Settings

Manage photos

28 photos stored
4.94 GB used of 32 GB

0.69 GB videos
0.01 GB photos
4.24 GB system

Show/hide photos

Delete photos
Delete one or multiple photos

Import photos
Import photos from external storage(e.g.microSD card)

Transfer from computer
Transfer photos using USB connection

Export photos
Export photos to external storage(e.g.microSD card)

Play from external storage
Play photos directly from external storage(e.g.microSD card)

Show/hide photos

Select which photos to hide by tapping them. Hidden photos will NOT be deleted from your frame and you can always select them to be shown again.

Use  to hide or show all photos.

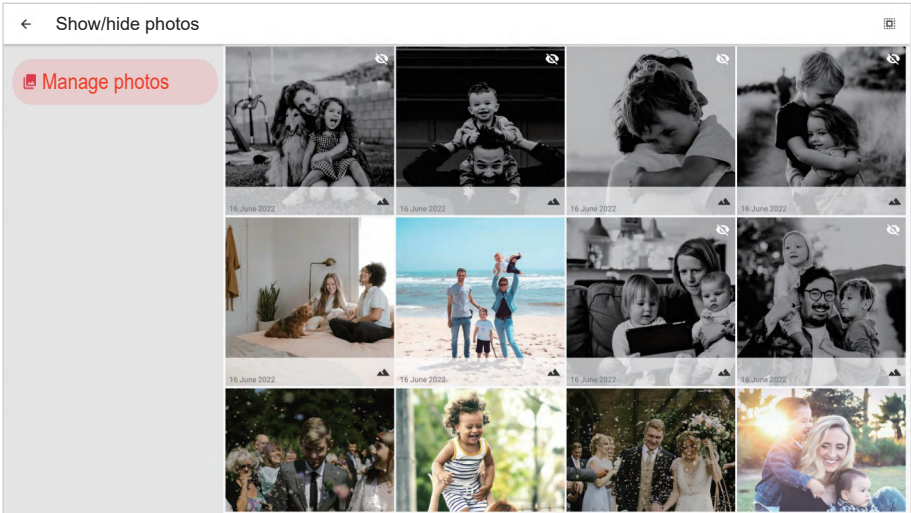

Delete photos

Select photos that you want to permanently delete from your frame by tapping the photo.

Use  to select or deselect all and  to permanently delete the selected photos.

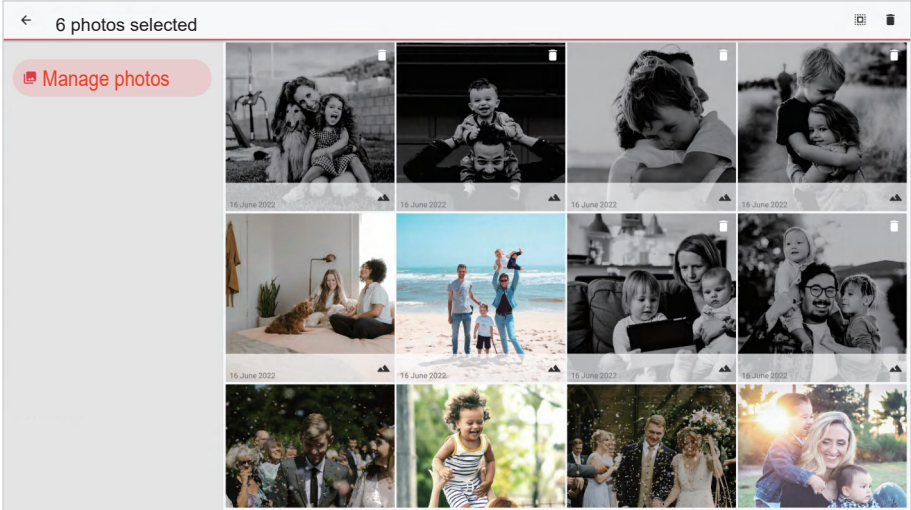

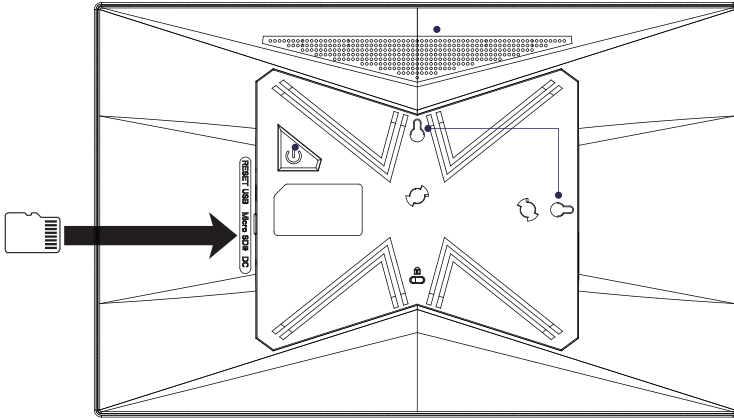

Import photos

Allows you to import photos from an external storage (e.g. microSD card).



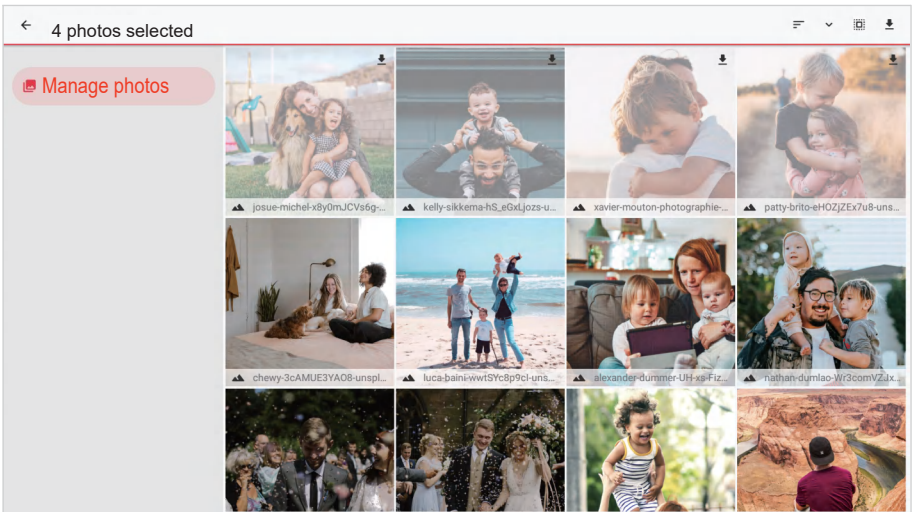

Before you try to import photos, make sure you have an external storage (e.g. micro SD card) inserted into your frame with the photos you wish to import.



Start by selecting the photos that you want to import onto your frame. Once selected tap the import button  to start the import process.

Use  to select or deselect all photos on the external storage (e.g. micro SD card).

Use  to set the sort order of photos before import and  to order by ascending/  descending.

Manage Photos continued

Transfer from computer

Allows you to transfer photos from a computer using a USB cable. Enable the feature and then follow the on-screen guide for step-by-step instructions on how to transfer photos to your frame.

Export photos

Allows you to export photos from the frame to external storage (e.g. microSD card).

The export function will export all photos on the frame as well as profile pictures.

Play from external storage

Allows you to playback photos and videos directly from an external storage (e.g. microSD card) without taking up space on the frame.

My Friends

This list contains all the connected friends that are allowed to send photos to your frame.

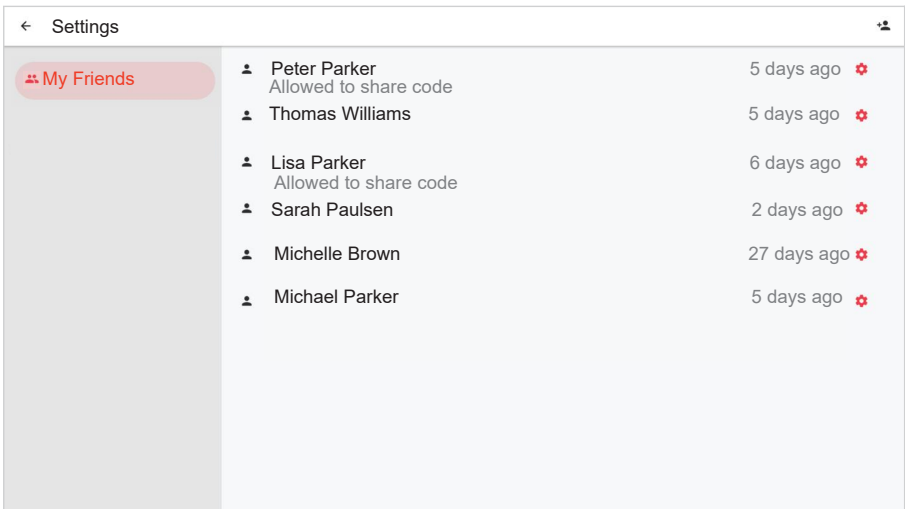

Change options for a friend

Click the options icon  to open the friend options menu. From here you can allow / disallow if a friend may share the code to the frame. If this is enabled the friend can retrieve and share the code to the frame from his/her app.

From the options menu you can also delete a friend, by pressing the DELETE FRIEND button. This will remove the friend from the list and thereby remove their permission to send photos to the frame. You will then be asked to confirm the removal and if you would like to remove all photos previously received from this friend.

Add person

To allow a new person to send you photos, simply tap the add friend button  and share the presented code in whatever way you prefer.

Display

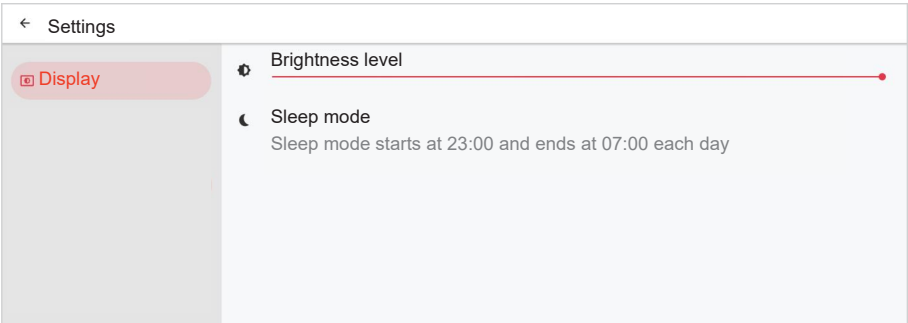

Brightness level

Adjust the brightness level of the screen.

Sleep mode

Frameo offers a sleep mode which turns off the screen to reduce power consumption. The default setting is to turn off the screen at 23:00 and turn on the screen again at 07:00. To change this just set the sleep mode start/end time.

Your frame is not powered down or in standby, so you will still be able to receive photos during sleep mode.

Slideshow

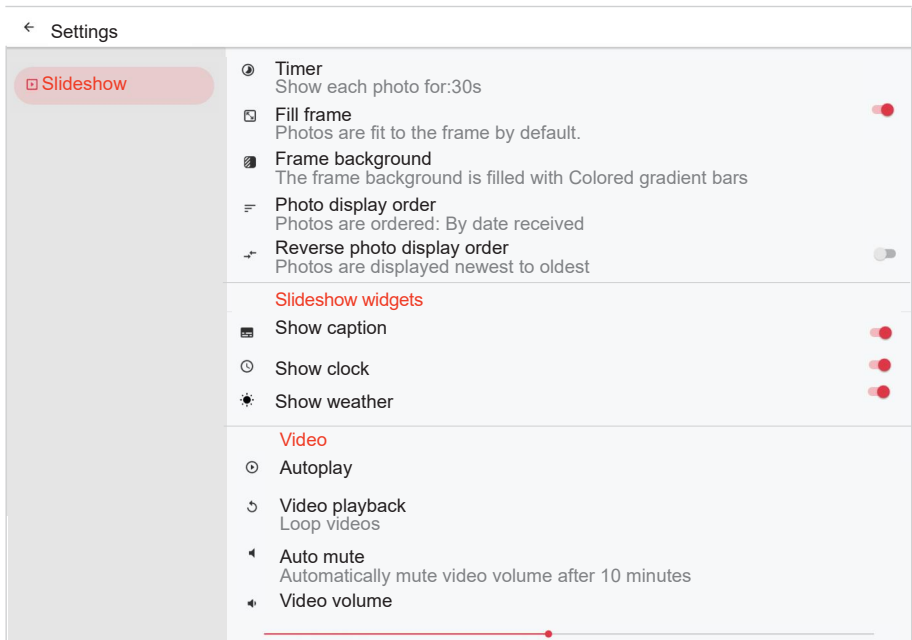

Slideshow continued

Timer

Set the duration that a photo should be displayed before showing the next photo.

Fill frame

Set the default frame photo setting. Check to set default to fill which makes the photos fit the device screen according to the most important part of the photo. Uncheck to make the photo fit inside the screen of the device, adding background bars on the sides or top/bottom.

Frame background

Choose between several different frame background options to be shown as bars if the photo does not fill the screen.

Photo display order

Sets the order in which your photos are displayed on the frame.

- By date taken: Photos are shown in order of when it was taken.
- By date received: Photos are shown in order of when it was received.
- Shuffle: Photos are shuffled and shown in a random order.

Show caption

Set whether or not to display the captions that your friends have sent with the photo. Check to display captions. Uncheck to hide captions.

Show clock

Set whether or not to display the clock widget in the upper-right corner of the slideshow.

Show weather

Set whether or not to display the weather widget in the upper-right corner of the slideshow.

Reverse photo display order

Sets if photos are displayed newest to oldest or oldest to newest.

Autoplay

Enables/disables autoplay of videos in the slideshow. Videos can always be manually started regardless of this setting.

Video playback

Determines how videos should be played when autoplay is enabled.

- Loop videos: The video will loop until the slideshow timer is up.
- Play once: The video will play once and show its thumbnail until the timer is up.
- Play once and continue: The video will play once and continue to the next photo, or video, once it completes.

Auto mute

Enable to automatically mute the video volume after a short period of time of not interacting with the frame.

Video volume

Adjust the volume level for video sounds on the frames.

Wi-Fi

Set which Wi-Fi the frame connects to. If you are connecting to a network with a captive portal Connection status will say that Wi-Fi login is required and show . Tap this to open a login screen where you can enter credentials to access the network.

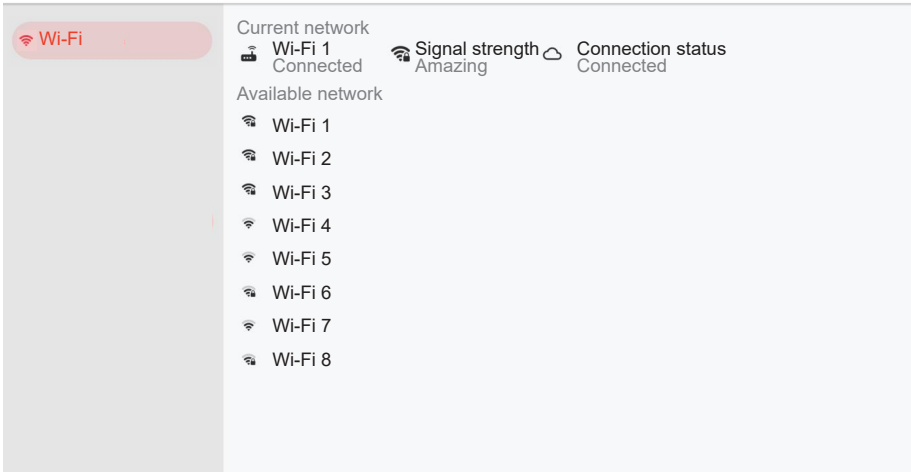

Wi-Fi details

Use ⓘ to show details about the current connected Wi-Fi.

Reset Wi-Fi

Use ⋮ to delete all Wi-Fi information and restart your frame.

Notifications

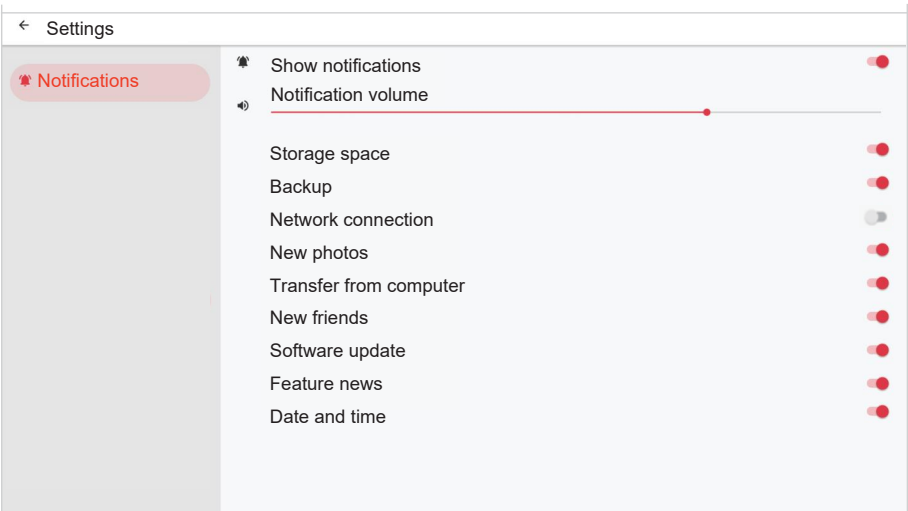

Show notifications

Enables/disables whether notifications are shown in the slideshow (e.g. when a new photo is received).

Notifications continued

Notification volume

Adjust the volume level for notification sounds.

Storage space

Enables/disables notifications shown when frame storage is low.

Backup

Enables/disables notifications shown if automatic backup has failed.

Transfer from computer

Enables/disables notifications shown when transferring from computer.

New photos

Enables/disables notifications shown when receiving new photos.

Date and time

Enables/disables notifications shown if time or date is not set correctly.

New friends

Enables/disables notifications shown when new friends are added.

Software update

Enables/disables notifications shown when a software update has been installed.

Feature news

Enables/disables notifications shown when new exciting features are added.

Date and time

Enables/disables notifications shown if time or date is not set correctly.

Backup and Restore

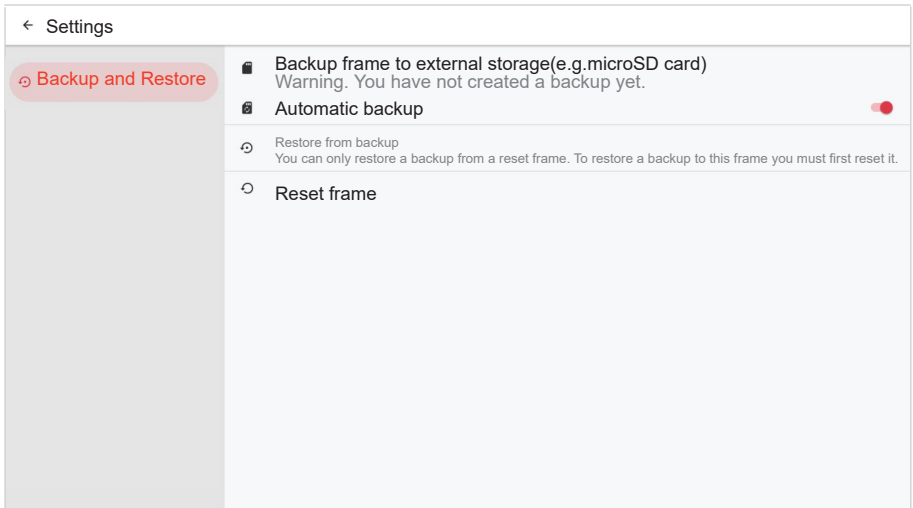

Backup and Restored continued

Backup frame to external storage (e.g. microSD card)

Tap to make a backup of your photos, friends and settings. The time of the latest successful backup is also displayed here.

Any existing backup on the external storage will be overridden!

Automatic backup

If checked, your frame will automatically make a backup within 30 hours of receiving new photos or making changes to your frame.

Restore from backup

To ensure your precious memories will never be lost, please restore from backup in time. Before you attempt to restore your frame, start by confirming that your backup is up-to-date. This is done by confirming the date under "Backup frame to external storage (e.g. microSD card)". If e.g. the last backup is too old or if no backup is made, then press the "Backup frame to external storage (e.g. microSD card)" button to make a new backup.

To keep both the old and the new frame operational at the same time after restoring from backup, please make sure that both frames are updated to the latest version beforehand.

If you wish to restore a backup on a frame that has already been setup, then you must first reset the frame. This is done by pressing the "Reset frame" button. This will delete all data on the Frameo and reset the Frameo to its setup screen.

On the setup screen you can select the "Restore from backup" button which will restore your frame according to the backup.

If the "Restore from backup" button isn't visible, then confirm that the external storage (e.g. microSD card) is correctly mounted.

Reset frame

Removes all data from your frame.

This will permanently remove all your photos, friends/connections and settings.

Help

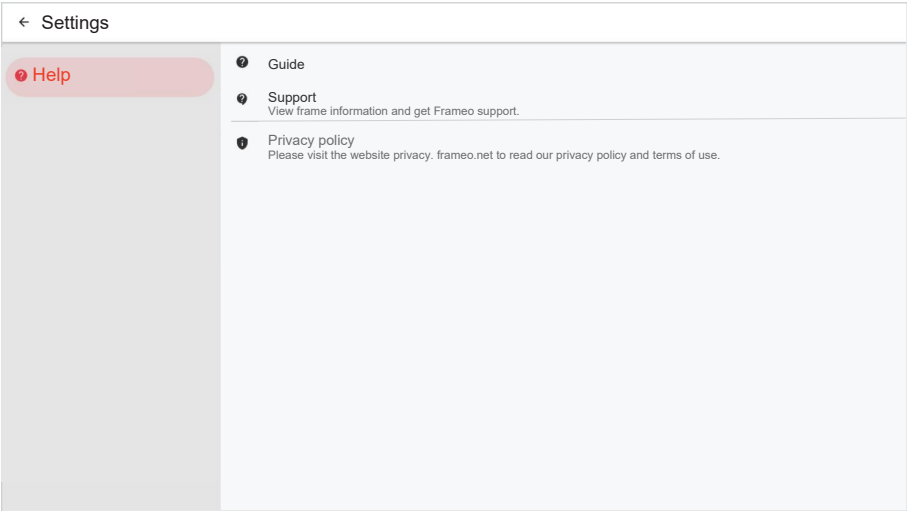

Guide

Shows the quick start guide, which was shown when you first started the frame.

Support

Find contact information for Frameo's support team, and find technical device information.

The menu features a special QR code that is there for our support staff to scan. It contains additional device details and information, enabling our support team to efficiently address your specific concerns and provide accurate assistance. Simply take a photo of the QR code and share it with our support staff.

About

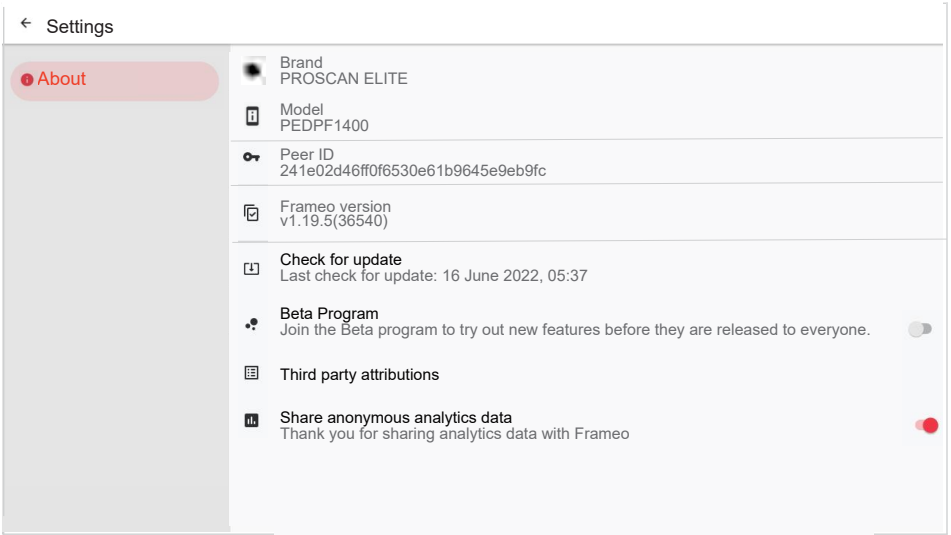

Peer ID

This is a unique ID for your photo frame. When contacting our support, please provide this ID with your message.

Frameo version

Shows what version of the Frameo software is currently installed on your frame.

Check for update

Check if an update is available for your frame.

Beta program

If checked the device will join the Beta program where it will receive updates more frequently and before normal release devices

Third party attributions

Open source libraries

Opens a list of open source libraries used in the app and their licenses

Share anonymous analytics data

Sharing anonymous analytics data helps us tremendously to improve the Frameo software. We understand if you do not wish to share this data with us. Keep it checked if you wish to help us improve Frameo. Set unchecked to deny the sharing of anonymous analytics data.

Product Specification

OS	Android 11
CPU	Rockchip RK3326S Quad-core processor
System RAM	1GB DDR III
Memory	32GB NAND Flash
DISPLAY	14.1" 1280x800 resolution LCD TN touchscreen
Touch Panel	2Point Capacitive touch screen
Wi-Fi	802.11b/g/N
Picture format	JPEG&PNG

Warning: Changes or modifications to this unit not expressly approved by the party responsible for compliance could void the user's authority to operate the equipment.

NOTE: This equipment has been tested and found to comply with the limits for a Class B digital device, pursuant to Part 15 of the FCC Rules. These limits are designed to provide reasonable protection against harmful interference in a residential installation. This equipment generates, uses and can radiate radio frequency energy and, if not installed and used in accordance with the instructions, may cause harmful interference to radio communications.

Please note there is no guarantee that interference will not occur in a particular installation. If this equipment does cause harmful interference to radio or television reception, which can be determined by turning the equipment off and on, the user is encouraged to try to correct the interference by one or more of the following measures:

Reorient or relocate the receiving antenna.

Increase the separation between the equipment and receiver.

Connect the equipment into an outlet on a circuit different from that to which the receiver is connected.

Consult the dealer or an experienced radio/TV technician for help.

This device complies with Part 15 of the FCC Rules. Operation is subject to the following two conditions:

(1) this device may not cause harmful interference.

(2) this device must accept any interference received, including interference that may cause undesired operation.

Radiation Exposure Statement

This equipment complies with FCC radiation exposure limits set forth for an uncontrolled environment. This equipment should be installed and operated with minimum distance 20cm between the radiator and your body.

To make a warranty claim, please email support2@curtiscs.com or call 1-800-968-9853.

90 day Warranty

This product is warranted to be free from defects in material and workmanship for a period of ninety (90) days from the date of original delivery to the consumer. During this period, your exclusive remedy is repair or replacement of this product or component found to be defective, at our option; however, you are responsible for all costs associated with returning the product to us. If the product or component is no longer available, we will replace with a similar one of equal or greater value. Prior to a replacement being sent, the product must be rendered inoperable or returned to us.

This warranty does not cover glass, filters, wear from normal use, use not in conformity with the printed directions., or damage to the product resulting from accident, alteration, abuse, or misuse. This warranty extends only to the original consumer purchaser or gift recipient. Keep the original sales receipt, as proof of purchase is required to make a warranty claim. This warranty is void if the product is used for other than single-family household use or subjected to any voltage and waveform other than as on the specified rating on the label (e.g., 120V~60Hz).

We exclude all claims for special, incidental, and consequential damages caused by breach of express or implied warranty. All liability is limited to the amount of the purchase price. **Every implied warranty, including any statutory warranty or condition of merchantability or fitness for a particular purpose, is disclaimed except to the extent prohibited by law, in which case such warranty or condition is limited to the duration of this written warranty.** This warranty gives you specific legal rights. You may have other legal rights that vary depending on where you live. Some states or provinces do not allow limitations on implied warranties or special, incidental, or consequential damages, so the foregoing limitations may not apply to you.

For faster service, locate the model, type, and serial numbers on your appliance.

ATTACH YOUR PROOF OF PURCHASE HERE, PROOF OF PURCHASE IS REQUIRED TO OBTAIN WARRANTY SERVICE.

Please have the following information available when you contact the Support Team:

- Name, address and telephone number.
- Model number and serial number.
- A clear, detailed description of the problem.
- Proof of purchase including dealer or retailer name, address and date of purchase.