

1 Safety Human Exposure

1.1 Radio Frequency Exposure Compliance

1.1.1 Electromagnetic Fields

RESULT:

Pass

Report No. : CN2303L1 003
Test item : 15W Magnetic Wireless Charger
Identification / Type No. : HKWP11071-15EL
FCC ID : 2ATF5-67590
Test standard : CFR47 FCC Part 2: Subpart J Section 1.1310
 : FCC CFR 47 Part 1(1.1310) KDB 680106 D01 v03

According to the table 1 of FCC Part 2.1310, the reference limit as below:

Frequency range (MHz)	Electric field strength (V/m)	Magnetic field strength (A/m)	Power density (mW/cm ²)	Averaging time (minutes)
(A) Limits for Occupational/Controlled Exposure				
0.3-3.0	614	1.63	*100	6
3.0-30	1842/f	4.89/f	*900/f ²	6
30-300	61.4	0.163	1.0	6
300-1,500			f/300	6
1,500-100,000			5	6
(B) Limits for General Population/Uncontrolled Exposure				
0.3-1.34	614	1.63	*100	30
1.34-30	824/f	2.19/f	*180/f ²	30
30-300	27.5	0.073	0.2	30
300-1,500			f/1500	30
1,500-100,000			1.0	30

f = frequency in MHz * = Plane-wave equivalent power density

Test Setup:

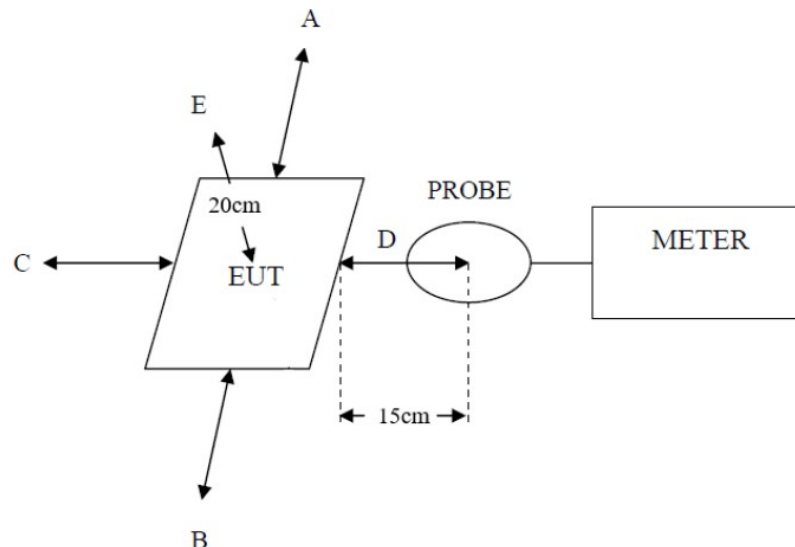

Test Result:

Table: H-Field Strength at 15 cm from the edges surrounding the EUT and 20cm from the top surface of the EUT

For WPT 5W:

EUT Test Mode	Measured H-Field Strength Values (A/m)					50% Limit (A/m)	Limit (A/m)	Result
	Test Position Top	Test Position front	Test Position rear	Test Position left	Test Position right			
1% Battery Level	0.32	0.34	0.31	0.36	0.33	0.815	1.63	Pass
50% Battery Level	0.31	0.34	0.30	0.35	0.32	0.815	1.63	Pass
99% Battery Level	0.30	0.33	0.29	0.35	0.30	0.815	1.63	Pass

For WPT 15W:

EUT Test Mode	Measured H-Field Strength Values (A/m)					50% Limit (A/m)	Limit (A/m)	Result
	Test Position Top	Test Position front	Test Position rear	Test Position left	Test Position right			
1% Battery Level	0.43	0.41	0.38	0.35	0.36	0.815	1.63	Pass
50% Battery Level	0.42	0.41	0.37	0.35	0.35	0.815	1.63	Pass
99% Battery Level	0.41	0.40	0.36	0.34	0.35	0.815	1.63	Pass