



FCC&ISED RF Test Report

Product Name: Smart Watch

Model Number: JPT-B19

Report No.: SYBH(Z-RF)20210626005001-2003

FCC ID: 2ATEYJPT-B19

IC : 25182-JPTB19

Authorized	Name	Date
Prepared by: (Test Engineer)	<i>Qin Jiawei</i>	2021-09-15
Reviewed by: (Test Engineer)	<i>Wen Hongyun</i>	2021-09-15
Approved by: (Lab Manager)	<i>He Hao</i>	2021-09-15

Reliability Laboratory of Huawei Technologies Co., Ltd.

(Global Compliance and Testing Center of Huawei Technologies Co., Ltd.)

No.2, New City Avenue, Songshan Lake Sci. & Tech. Industry Park, Dongguan, 523808, P.R.C

Telephone: +86 769 23830808

Fax: +86 769 23837628

※ ※ Notice ※ ※

1. The laboratory has passed the accreditation by The American Association for Laboratory Accreditation (A2LA). The accreditation number is 2174.01.
2. The laboratory has been recognized by the US Federal Communications Commission (FCC) to perform compliance testing subject to the Commission's Certification rules. The Designation Number is CN1173, and the Test Firm Registration Number is 294140.
3. The laboratory has been recognized by the Innovation, Science and Economic Development Canada (ISED) to test to Canadian radio equipment requirements. The CAB identifier is CN0003, and the ISED# is 21741.
4. The laboratory (Reliability Lab of Huawei Technologies Co., Ltd) is also named "Global Compliance and Testing Center of Huawei Technologies Co., Ltd", the both names have coexisted since 2009.
5. The test report is invalid if not marked with the signatures of the persons responsible for preparing and approving the test report.
6. The test report is invalid if there is any evidence of erasure and/or falsification.
7. The test report is only valid for the test samples.
8. Content of the test report, in part or in full, cannot be used for publicity and/or promotional purposes without prior written approval from the laboratory.
9. If any question about this report, please contact the laboratory (PublicGCTC@huawei.com).

MODIFICATION RECORD

No.	Report No	Modification Description
1	SYBH(Z-RF)20210626005001-2003	First release.

DECLARATION

Type	Description
Multiple Models Applications	<input checked="" type="checkbox"/> The present report applies to single model. <input type="checkbox"/> The present report applies to several models. The practical measurements are performed with the model The present report only presents the worst test case of all modes, see relevant test results for detailed.

1 Table of contents

1	Table of contents	4
2	General Information	5
2.1	Test standard/s	5
2.2	Test Environment	5
2.3	Test Laboratories	5
2.4	Applicant and Manufacturer	5
2.5	Application details	5
3	Test Summary	6
4	Description of the Equipment under Test (EUT)	7
4.1	General Description	7
4.2	EUT Identity	7
4.3	Technical Description	8
5	General Test Conditions / Configurations	10
5.1	Test Modes	10
5.2	EUT Configurations	10
5.3	Antenna requirements	11
5.4	Description of tests	12
5.5	Test Setups	14
5.6	Test Conditions	17
6	Main Test Instruments	18
6.1	Current Test Project/Report	18
7	Measurement Uncertainty	19
8	Appendixes	19

2 General Information

2.1 Test standard/s

Applied Rules :	47 CFR FCC Part 2, Subpart J 47 CFR FCC Part 15, Subpart C ISED RSS-Gen Issue 5 ISED RSS-247 Issue2
Test Method :	FCC KDB 558074 D01 DTS Meas Guidance v05r02 ANSI C63.10-2013, American National Standard for Testing Unlicensed Wireless Devices.

2.2 Test Environment

Temperature :	TN	15 to 30	°C during room temperature tests
Ambient Relative Humidity:	25 to 75 %		
Atmospheric Pressure:	Not applicable		
Power supply :	VN	3.82	V DC by Battery

NOTE 1: 1) VN= nominal voltage, VL= low extreme test voltage, VH= High extreme test voltage;

TN= normal temperature, TL= low extreme test temperature, TH= High extreme test temperature.

NOTE 2: The values used in the test report may be stringent than the declared.

2.3 Test Laboratories

Test Location 1 :	RELIABILITY LABORATORY OF HUAWEI TECHNOLOGIES CO., LTD.
Address of Test Location 1 :	No.2 New City Avenue, Songshan Lake Science & Technology Industry Park Dongguan, Guangdong, 523808, People's Republic of China
Temperature of Test Location 1 :	25°C
Relative humidity of Test Location 1 :	55 %

2.4 Applicant and Manufacturer

Company Name :	Huawei Device Co., Ltd.
Address :	No.2 of Xincheng Road, Songshan Lake Zone, Dongguan, Guangdong 523808, People's Republic of China

2.5 Application details

2.5.1 Current Test Project/Report

Date of Receipt Sample:	2021-07-14
Start of test:	2021-07-15
End of test:	2021-09-15

3 Test Summary

Test Item	FCC Rule No.	ISED Rule No.	Requirements	Test Result	Verdict	Testing location
DTS (6 dB) Bandwidth	15.247(a)(2)	RSS-247, 5.2	≥ 500 kHz.	Appendix A	Pass	Test Location 1
Occupied Bandwidth	---	RSS-247, 5.2 RSS-Gen, 6.7	No limit	Appendix B	Pass	Test Location 1
Duty Cycle	KDB 558074 D01(6.0)	--	No limit	Appendix C	Pass	Test Location 1
Maximum Average Output Power	15.247(b)(3)	RSS-247, 5.4	FCC: For directional gain: Conducted < 30 dBm – (G[dBi] – 6 [dB]); Otherwise: Conducted < 30 dBm, ISED: Conducted < 30 dBm. EIRP < 36 dBm,	Appendix D	Pass	Test Location 1
Maximum Power Spectral Density Level	15.247(e)	RSS-247, 5.2	Conducted < 8 dBm/3 kHz.	Appendix E	Pass	Test Location 1
Band Edges Compliance	15.247(d)	RSS-247, 5.5	< -30 dB/100 kHz if total average power ≤ power limit.	Appendix F	Pass	Test Location 1
Unwanted Emissions into Non-Restricted Frequency Bands				Appendix G	Pass	Test Location 1
Unwanted Emissions into Restricted Frequency Bands (Radiated)	15.247(d) 15.209 (NOTE 1)	RSS-247, 5.5 RSS-Gen, §6.13 RSS-Gen, 8.10	FCC Part 15.209 field strength limit; RSS-Gen 8.10 field strength limit.	Appendix H	Pass	Test Location 1
AC Power Line Conducted Emissions	15.207	RSS-Gen, 8.8	FCC Part 15.207 conducted limit; RSS-Gen, 8.8 conducted limit.	Appendix I	Pass	Test Location 1

NOTE 1: According to KDB 558074 D01, antenna-port conducted measurements are acceptable as an alternative to radiated measurements for demonstrating compliance to the limits in the restricted frequency bands. If conducted measurements are performed, then proper impedance matching must be ensured and an additional radiated test for cabinet/case emissions will also be required.

NOTE2: The transmitter has an integral PCB loop antenna that is enclosed within the housing of the EUT and meets the requirements of FCC 15.203

4 Description of the Equipment under Test (EUT)

4.1 General Description

JPT-B19 is a smart watch; it can be communicated with mobile phone via Bluetooth. Watch also support alarm clock, intelligent user can judge the state of motion, scientific sleep monitoring, information assistance, heart rate monitoring, GPS functionalities and supports music playback and bluetooth calling. The BT/WIFI frequency is 2.4GHz.

Note 1: Only 2.4G WIFI test data included in this report.



4.2 EUT Identity

NOTE: Unless otherwise noted in the report, the functional boards installed in the units shall be selected from the below list, but not means all the functional boards listed below shall be installed in one unit.

4.2.1 Board

Board		
Description	Software Version	Hardware Version
Main Board	2.0.1.137	R2

4.2.2 Sub-Assembly

Sub-Assembly			
Sub-Assembly Name	Model	Manufacturer	Description
Battery	HB532729ECW	Huawei Technologies Co., Ltd.	Rated capacity: 455mAh Nominal Voltage:  +3.82V Charging Voltage:  +4.40V

4.3 Technical Description

NOTE: For the detailed technical descriptions, see the applicant/manufacturer's specifications or user manual.

Characteristic	Description		
IEEE 802.11 WLAN Mode Supported	<input checked="" type="checkbox"/> 802.11b	<input checked="" type="checkbox"/> 20 MHz,	
	<input checked="" type="checkbox"/> 802.11g	<input checked="" type="checkbox"/> 20 MHz	
	<input checked="" type="checkbox"/> 802.11n	<input checked="" type="checkbox"/> 20 MHz, <input type="checkbox"/> 40 MHz	
	<input type="checkbox"/> 802.11ax	<input type="checkbox"/> HE SU	<input type="checkbox"/> 20 MHz, <input type="checkbox"/> 40 MHz
		<input type="checkbox"/> HE ER SU	<input type="checkbox"/> 20 MHz: 106-Tone/242-Tone
		<input type="checkbox"/> HE TB	<input type="checkbox"/> 20 MHz: 26-Tone/52-Tone/106-Tone/242-Tone
<input type="checkbox"/> 40 MHz: 26-Tone/52-Tone/106-Tone/242-Tone/484-Tone			
<input type="checkbox"/> HE MU	<input type="checkbox"/> 20 MHz: 26-Tone/52-Tone/106-Tone/242-Tone <input type="checkbox"/> 40 MHz: 26-Tone/52-Tone/106-Tone/242-Tone/484-Tone		
TX/RX Operating Range	2412-2462 MHz	2407 MHz + N * 5 MHz, N = 1...11 (for 802.11b/g/n HT20).	
Baseband Modulation	802.11b : DBPSK/DQPSK/CCK(DSSS)		
	802.11g : BPSK/QPSK/16QAM/64QAM(OFDM)		
	802.11n : BPSK/QPSK/16QAM/64QAM(OFDM)		
Emission Designator	11M4G7D (for 802.11b mode), 16M7G7D (for 802.11g mod), 17M8G7D (for 802.11n20 mode),		
TX Power Control	<input type="checkbox"/> Supported, <input checked="" type="checkbox"/> Not Supported		
Standby Mode	<input type="checkbox"/> Supported, <input checked="" type="checkbox"/> Not Supported		
Equipment Type	<input checked="" type="checkbox"/> Stand-alone equipment, <input type="checkbox"/> Plug-in radio device, <input type="checkbox"/> Combined equipment		
Antenna	Description	Isotropic Antenna	
	Type	<input checked="" type="checkbox"/> Integral (permanent fixed antenna, which may be built-in, designed as an indispensable part of EUT) <input type="checkbox"/> Dedicated (removable antenna supplied with EUT, designed as an indispensable part of EUT)	
	Ports	<input checked="" type="checkbox"/> Ant 1, <input type="checkbox"/> Ant 2, <input type="checkbox"/> Ant 3	
	Smart System	<input checked="" type="checkbox"/> SISO (for 802.11b/g/n), <input type="checkbox"/> CDD (for 802.11g), 2 Tx & 2 Rx, <input type="checkbox"/> MIMO (for 802.11n), 2 Tx & 2 Rx, <input type="checkbox"/> Diversity (for 802.11b/g) : Tx & Rx	
	Gain	Ant 1: -3 dBi (per antenna port, max.)	
	Remark	When the EUT is put into service, the practical maximum antenna gain should NOT exceed the value as described above.	
	Power Supply	Type	<input type="checkbox"/> External DC mains, <input checked="" type="checkbox"/> Battery, <input type="checkbox"/> AC/DC Adapter,

Characteristic	Description
	<input type="checkbox"/> Powered over Ethernet (PoE). <input type="checkbox"/> USB <input type="checkbox"/> Other _____

5 General Test Conditions / Configurations

5.1 Test Modes

NOTE: Worst cases for each IEEE 802.11 mode are selected to perform tests.

Test Mode	Test Modes Description
11B	IEEE 802.11b with data rate of 1 Mbps using SISO mode.
11G	IEEE 802.11g with data rate of 6 Mbps using SISO mode.
11N20SISO	IEEE 802.11n with data rate of MCS0 and bandwidth of 20 MHz, using SISO mode

5.2 EUT Configurations

5.2.1 General Configurations

Configuration	Description
Test Antenna Ports	Until otherwise specified, - All TX tests are performed at all TX antenna ports of the EUT, and - All RX tests are performed at all RX antenna ports of the EUT.
Multiple RF Sources	Other than the tested RF source of the EUT, other RF source(s) are disabled or shutdown during measurements.
Sensors and Antenna	Sensors and Antenna optimization function should be disabled during testing by software method to get the stable maximum power and avoid the influence of uncertain conditions

5.2.2 Customized Configurations

Test Mode	Power Level Setting defined by Manufacturer
	ANT1
11B	14
11G	12
11N20SISO	12

5.3 Antenna requirements

Excerpt from §15.203 of the FCC Rules/Regulations:

“An intentional radiator antenna shall be designed to ensure that no antenna other than that furnished by the responsible party can be used with the device. The use of a permanently attached antenna or of an antenna that uses a unique coupling to the intentional radiator shall be considered sufficient to comply with the provisions of this section.”

The antennas of the **JPT-B19** are **permanently attached**.

There are no provisions for connection to an external antenna.

Conclusion:

The **EUT** unit complies with the requirement of §15.203.

Ch. Frequency (MHz)

Ch.	Frequency (MHz)
01	2412
.	.
.	.
06	2437
.	.
.	.
11	2462

Frequency/ Channel Operations

5.4 Description of tests

5.4.1 Bandwidth measurement

- (a) Connect EUT test port to spectrum analyzer.
- (b) Set the EUT to transmit maximum output power at 2.4GHz, then set the measured frequency number and test the bandwidth with spectrum analyzer.

5.4.2 Average output power

- (a) Connect EUT test port to spectrum analyzer.
- (b) Set the EUT to transmit maximum output power at 2.4GHz.
- (c) Then set the EUT to transmit at high, middle and low frequency and measure the conducted output power separately.

5.4.3 Band edge spurious emission

- (a) Connect EUT test port to spectrum analyzer
- (b) Set the EUT to transmit maximum output power at 2.4GHz.
- (c) Then set the EUT to transmit at high, low frequency and measure the conducted band edge spurious separately.

5.4.4 Conducted RF spurious

- (a) Connect EUT test port to spectrum analyzer
- (b) Set the EUT to transmit maximum output power at 2.4GHz.
- (c) Then set the EUT to transmit at high, middle and low frequency and measure the conducted spurious separately.

5.4.5 Power spectral density

- (a) Connect EUT test port to spectrum analyzer
- (b) Set the EUT to transmit maximum output power at 2.4GHz.
- (c) Then set the EUT to transmit at high, middle and low frequency and measure the conducted power spectral density.

5.4.6 Radiated spurious emission & spurious in restricted band

For frequency below 1GHz, the test site semi-anechoic chamber has met the requirement of NSA tolerance 4dB according to the standards: ANSI C63.10 (2013). The EUT was set-up on insulator 80cm above the Ground Plane. For frequency above 1GHz, the test site full-anechoic chamber has met the requirement of ANSI C63.10 (2013). The EUT was set-up on insulator 150cm above the Ground Plane.

The set-up and test methods were according to ANSI C63.10:2013. The Radiated Disturbance measurements were made using a Rohde and Schwarz Test Receiver and control software.

A preliminary scan and a final scan of the emissions were made by using test script of software; the emissions were measured using a Quasi-Peak Detector below 1GHz, Peak Detector and AV Detector above 1GHz. The maximal emission value was acquired by

adjusting the antenna height, polarisation and turntable azimuth in accordance with the software setup. Normally, the height range of antenna was 1m to 4m, and the azimuth range of turntable was 0° to 360°. The receive antenna has two polarizations V and H.

A portable or small unlicensed wireless device shall be placed on a non-metallic test fixture or other nonmetallic support during testing. The supporting fixture shall permit orientation of the EUT in each of three orthogonal (x, y, z) axis positions such that emissions from the EUT are maximized.

The EUT communicates with the BTS simulator through Air interface. The EUT operated on the typical channel.

Measurement bandwidth: 30 MHz – 1000 MHz: 120 kHz

Measurement bandwidth: 1000 MHz – 10th Carrier Frequency: 1 MHz

5.4.7 Conducted Emission at Power Port

The Table-top EUT was placed upon a non-metallic table 0.8 m above the horizontal metal reference ground plane. EUT was connected to LISN and LISN was connected to reference Ground Plane. EUT was 80cm from LISN. The set-up and test methods were according to ANSI C63.10: 2013.

Conducted Disturbance at AC Port measurements were undertaken on the L and N Lines. The emissions were measured using a Quasi-Peak Detector and Average Detector.

The EUT communicates with the BTS simulator through Air interface, the BTS simulator controls the Wireless Modem to transmitter the maximum power which defined in specification of product. The Wireless Modem operated on the typical channel.

Measurement bandwidth (RBW) for 150kHz to 30 MHz: 9 kHz;

5.5 Test Setups

5.5.1 Test Setup 1

The WLAN component's antenna ports(s) of the EUT are connected to the measurement instrument per an appropriate attenuator. The EUT is controlled by PC/software to emit the specified signals for the purpose of measurements.

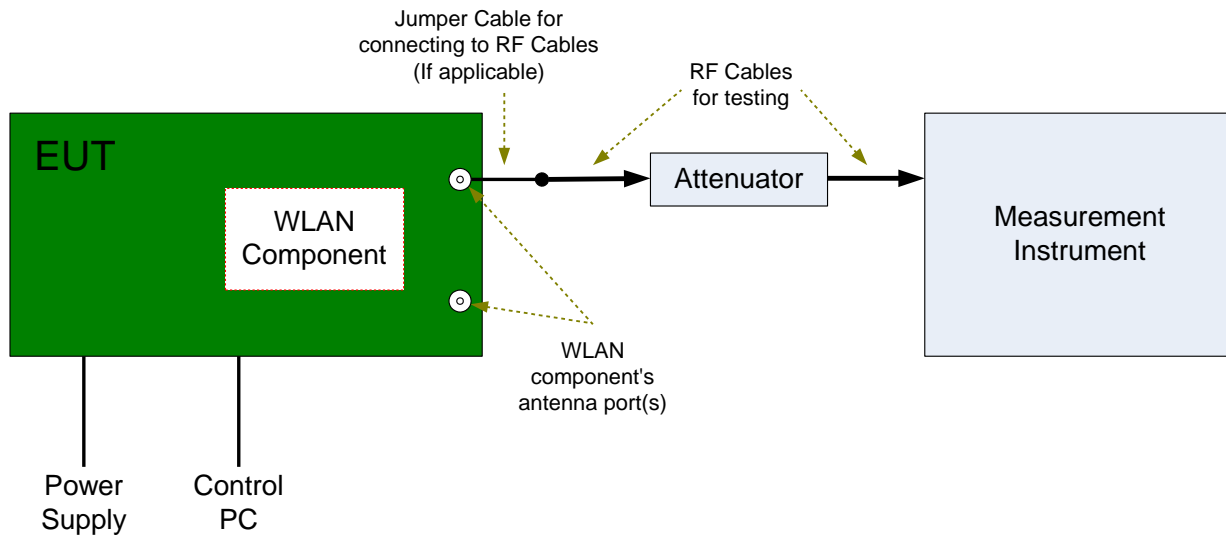

5.5.2 Test Setup 2

The semi-anechoic chamber and full-anechoic chamber has met the requirement of ANSI C63.4. The test distance is 3m. The setup is according to ANSI C63.4 and CAN/CSA-CEI/IEC CISPR 22.

The maximal emission value is acquired by adjusting the antenna height, polarisation and turntable azimuth. Normally, the height range of antenna is 1 m to 4 m, the azimuth range of turntable is 0° to 360°, and the receive antenna has two polarizations Vertical (V) and Horizontal (H).

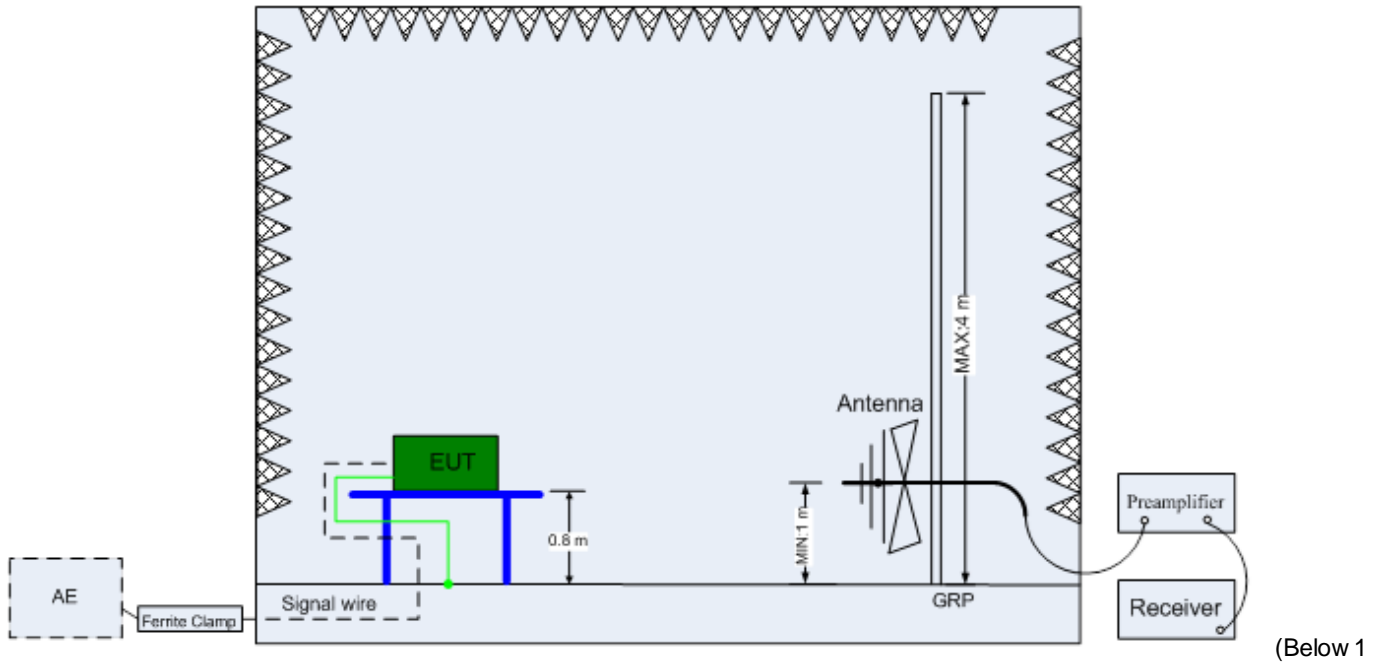

GHz)

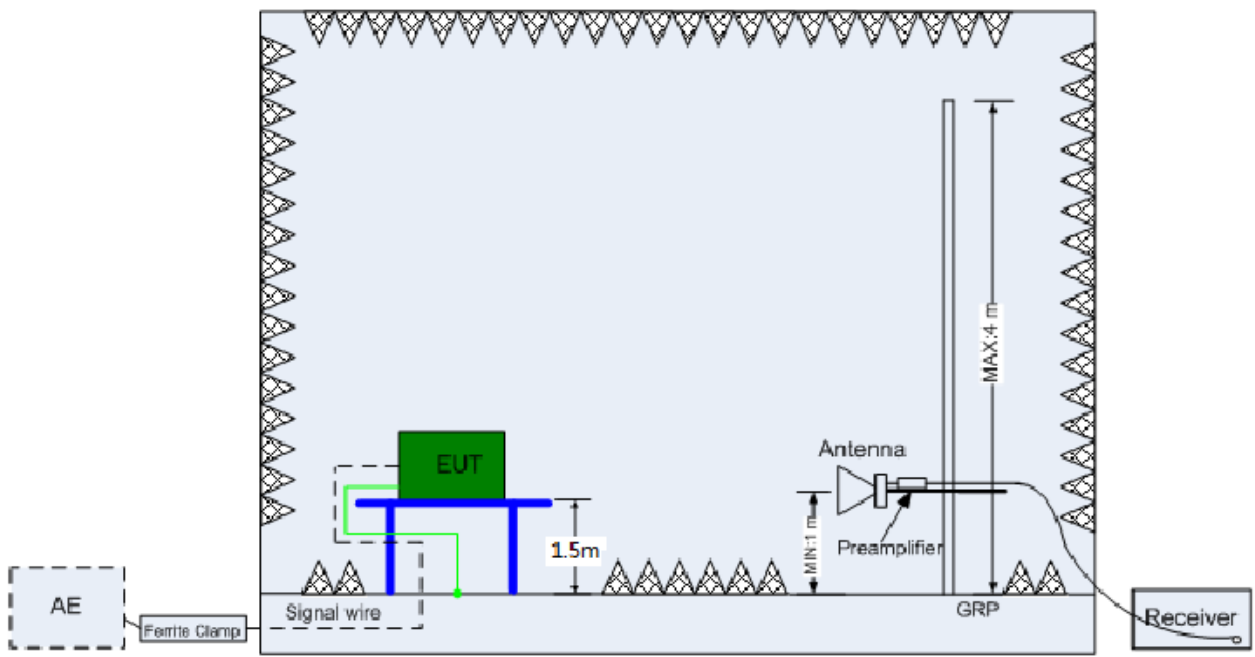

5.5.3 Test Setup 3

The mains cable of the EUT (maybe per AC/DC Adapter) must be connected to LISN. The LISN shall be placed 0.8 m from the boundary of EUT and bonded to a ground reference plane for LISN mounted on top of the ground reference plane. This distance is between the closest points of the LISN and the EUT. All other units of the EUT and associated equipment shall be at least 0.8m from the LISN.

Ground connections, where required for safety purposes, shall be connected to the reference ground point of the LISN and, where not otherwise provided or specified by the manufacturer, shall be of same length as the mains cable and run parallel to the mains connection at a separation distance of not more than 0.1 m.

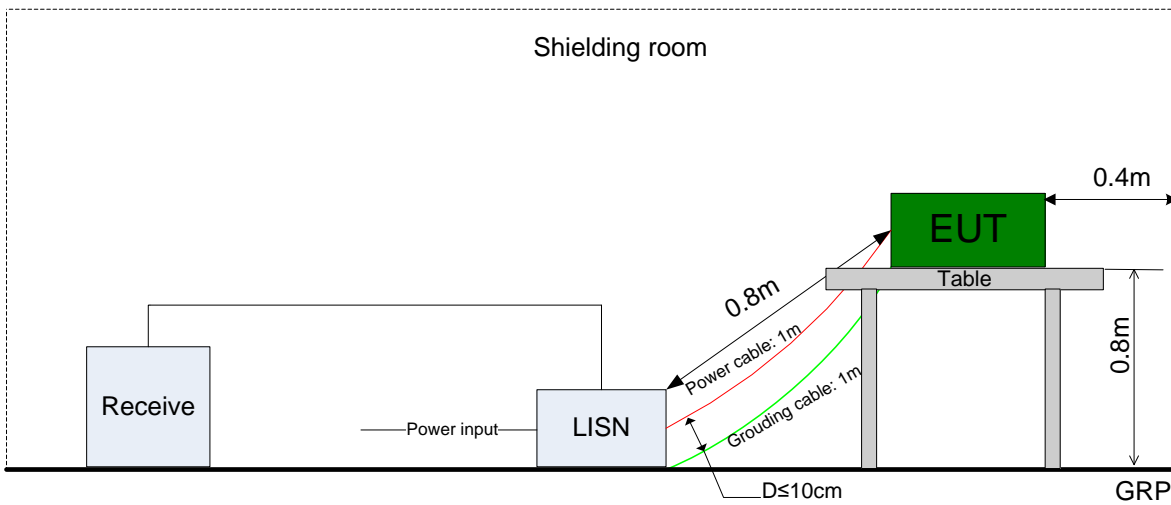

5.6 Test Conditions

Test Case	Test Conditions	
	Configuration	Description
DTS (6 dB) Bandwidth	Measurement Method	FCC KDB 558074 D01 §8.2 Option 1.
	Test Environment	TN/VN
	Test Setup	Test Setup 1
	EUT Configuration	All EUT conf. with Tx modes.
Occupied Bandwidth	Measurement Method	ANSI C63.10 Section 6.9.3
	Test Environment	TN/VN
	Test Setup	Test Setup 1
	EUT Configuration	All EUT conf. with Tx modes.
Maximum Conducted Average Output Power	Measurement Method	FCC KDB 558074 D01 §8.3.2.3
	Test Environment	TN/VN
	Test Setup	Test Setup 1
	EUT Configuration	All EUT conf. with Tx modes.
Maximum Power Spectral Density Level	Measurement Method	FCC KDB 558074 D01 §8.4
	Test Environment	TN/VN
	Test Setup	Test Setup 1
	EUT Configuration	All EUT conf. with Tx modes.
Band Edges Compliance	Measurement Method	FCC KDB 558074 D01 §8.7
	Test Environment	TN/VN
	Test Setup	Test Setup 1
	EUT Configuration	All EUT conf. with Tx modes.
Unwanted Emissions into Non-Restricted Frequency Bands	Measurement Method	FCC KDB 558074 D01 §8.5
	Test Environment	TN/VN
	Test Setup	Test Setup 1
	EUT Configuration	All EUT conf. with Tx modes.
Unwanted Emissions into Restricted Frequency Bands (Radiated)	Measurement Method	ANSI C63.10; FCC KDB 558074 D01 §8.6, Radiated
	Test Environment	TN/VN
	Test Setup	Test Setup 2
	EUT Placement	<input checked="" type="checkbox"/> Flatwise, <input checked="" type="checkbox"/> Upright, <input checked="" type="checkbox"/> Hung
	EUT Configuration	All EUT conf. with Tx modes.
AC Power Line Conducted Emissions	Measurement Method	AC mains conducted.
	Test Environment	TN/VN
	Test Setup	Test Setup 3
	EUT Configuration	11B@Ant1 (Worst Conf.).

6 Main Test Instruments

6.1 Current Test Project/Report

Main Test Equipments(BT/WIFI test system)					
Equipment Name	Manufacturer	Model	Serial Number	Cal Date	Cal-Due
Power Sensor	R&S	NRP2	103085/106211	2021/03/13	2022/03/12
Spectrum Analyzer	R&S	FSW26	101787	2021/07/02	2022/07/01
Universal Radio Communication Tester	R&S	CMW500	164698	2021/03/13	2022/03/12

Main Test Equipments(RE test system)					
Equipment Name	Manufacturer	Model	Serial Number	Cal Date	Cal-Due
Test receiver	R&S	ESW44	101878	2021/01/31	2022/01/30
LOOP Antennas(9kHz-30MHz)	R&S	HFH2-Z2	100262	2021/07/11	2023/07/10
Trilog Broadband Antenna (30M~3GHz)	SCHWARZB ECK	VULB 9163	9163-1303	2020/08/10	2022/08/09
Trilog Broadband Antenna (1GHz~18GHz)	SCHWARZB ECK	HF907	100305	2021/05/08	2023/05/07
Trilog Broadband Antenna (18GHz~40GHz)	SCHWARZB ECK	BBHA 9170	BBHA9170647	2019/10/29	2021/10/28
Software Information					
Test Item	Software Name		Manufacturer	Version	
RE	EMC32		R&S	V10.60.20	

Main Test Equipments(CE test system)					
Equipment Name	Manufacturer	Model	Serial Number	Cal Date	Cal-Due
Test receiver	R&S	ESU26	100150	2020/11/06	2021/11/05
Artificial Mains Network	R&S	ENV4200	100134	2021/03/14	2022/03/13
Software Information					
Test Item	Software Name		Manufacturer	Version	
CE	EMC32		R&S	V9.25.0	

7 Measurement Uncertainty

For a 95% confidence level, the measurement expanded uncertainties for defined systems, in accordance with the recommendations of ISO 17025 as following:

Test Item		Extended Uncertainty
Transmit Output Power Data	Power [dBm]	U = 0.39 dB
RF Power Density, Conducted	Power [dBm]	U = 0.66 dB
Bandwidth	Magnitude [kHz]	20MHz: U=41.78kHz 40MHz: U=82.12kHz
Band Edge Compliance	Disturbance Power [dBm]	U = 0.9 dB
Spurious Emissions, Conducted	Disturbance Power [dBm]	20MHz~3.6GHz: U=0.88dB 3.6GHz~8.4GHz: U=1.08dB 8.4GHz~13.6GHz: U=1.24dB 13.6GHz~22GHz: U=1.34dB 22GHz~26.5GHz: U=1.36dB
Field Strength of Spurious Radiation	ERP/EIRP [dBm]	For 3 m Chamber: U = 3.868 dB (9 kHz to 150 kHz) U = 3.782 dB (150 kHz to 30 MHz) U = 5.24 dB (30 MHz-1 GHz) U = 4.84 dB (1 GHz-18 GHz) U = 4.62 dB (18 GHz-26.5 GHz)
AC Power Line Conducted Emissions	Disturbance Voltage[dBμV]	U=2.3 dB
Duty Cycle	Duty Cycle [%]	U=±2.06 %

8 Appendixes

Appendix No.	Description
SYBH(Z-RF)20210626005001-2003-A	Appendix for 2.4G WLAN(Conducted)
SYBH(Z-RF)20210626005001-2003-B	Appendix for 2.4G WLAN(Radiated)

Note: We tested all modes & antennas, and the data presented in the appendix is the worst case.

END